

**YAMAHA**

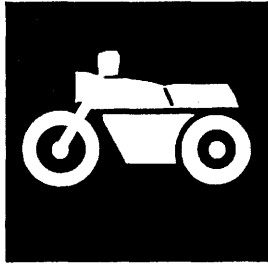

**PARTS  
CATALOGUE**

**YZ80J ✓ (4ES6)** U.S.A., CANADA, NEWZEALAND  
S.AFRICA, EUROPE

**YZ80LWJ (4LC4)** NEWZEALAND, EUROPE

**YAMAHA**  
**GENUINE**  
Parts & Accessories

[www.legends-yamaha-enduros.com](http://www.legends-yamaha-enduros.com)

174ES-100E1

[www.legends-yamaha-enduros.com](http://www.legends-yamaha-enduros.com)

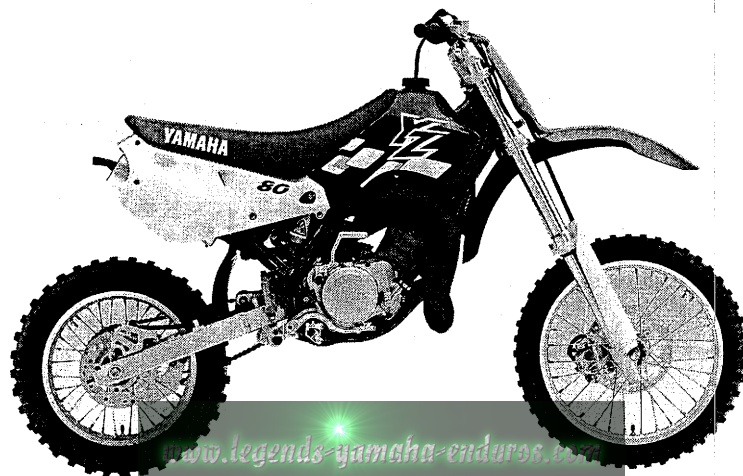

A3

# FOREWORD

This Parts Catalogue is related to the parts for the model(s) in the below frame. When you are ordering replacement parts, please refer to this Parts Catalogue and quote both part numbers and part names correctly.

YZ80J(4ES6), YZ80LWJ(4LC4)

1. Modifications or additions which have been made after issue of the Parts Catalogue will be announced in the Yamaha Parts News.  
It is advisable that you make necessary corrections to the Parts Catalogue according to the Yamaha Parts News.

2. Abbreviations

The following abbreviations are used in this Parts Catalogue.

- "UR": Use specified parts number.
- "UN" Use as many as needed.
- "AP" Alternate Parts
- "LM" Local Made (Parts need to be ordered locally)
- "F#" Frame No. (Applicable machine No.)

3. Parts, which are to be supplied in an assembly, are listed with a dot (.) in front of the part name as shown below.

EXAMPLE  
 CARBURETOR ASSY  
 . JET, PILOT  
 . NOZZLE, MAIN

4. Number of component for assembly

The numeral appearing to the right of each component part indicates the quantity of parts for each assembly unit.

EXAMPLE

PART NO.	DESCRIPTION	Q'TY	REMARKS
2F5-83310-60	FRONT FLASHER LIGHT ASSY	2	
115-83311-60	. BULB (6V-18W)	1	

5. Applicable colors of graphics are represented in the "REMARKS" as shown below.

PART NO.	DESCRIPTION	Q'TY	REMARKS
2N4-24110-00-X5	FUEL TANK COMP.	1	MAXIM RED
3J1-24240-10	. GRAPHIC, FUEL TANK	1	for MXR

6. Applicable Serial No.

① Engine Serial No.

② Frame Serial No.

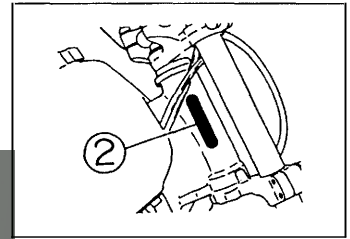
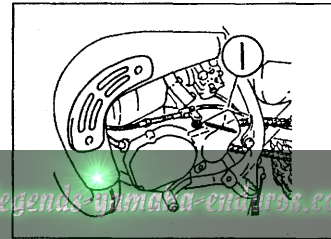

[www.legend-yamaha-ent-rps.com](http://www.legend-yamaha-ent-rps.com)

7. Note that the illustrations are for reference in finding parts numbers, not to be used for assembling. When assembling, please use the applicable service manual.

8. The asterisk (\*) before a reference number indicates modification items after the first edition.

# MODEL LABEL

(1) A label called "Model Label" is affixed in the location as indicated in (3) below. When using this parts catalogue, please be sure to cross-refer the "model code – production code No." in the catalogue to the "model code – production code No." indicated on the Model Label affixed onto the product concerned.

(2) "Model Label" Indication

	① Model Type Code ② Production Code No. ③ Colouring Type	ex 
--	--	--------

(3) Model Label Affixing Location

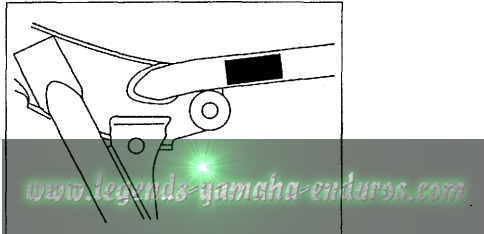

(4) Model Code – Production Code Number of Model Listed in This Parts Catalog

Model code	Production code No.	Country (destination)	Model code	Production code No.	Country (destination)
4ES6	010	USA			
	020	CANADA			
	030	NEWZEALAND			
	040	S. AFRICA			
	050	ENGLAND			
	060	SWEDEN			
4LC4	010	NEWZEALAND			
	020	ENGLAND			
	030	SWEDEN			

(5) Colouring Information

Colouring type code	Colour code	Colour Name	Abbreviation
A	00EX	INK BLUE	IKB

# CONTENTS

## ENGINE

Cylinder .....	B2
Crankshaft. Piston .....	B3
Water Pump .....	B4
Radiator. Hose .....	B5
Intake .....	B6
Carburetor .....	B7~B8
Exhaust .....	B9
Crankcase .....	B10
Crankcase Cover 1 .....	B11
Starter .....	B12
Clutch .....	B13
Transmission .....	B14~B15
Shift Cam. Fork .....	C2
Shift Shaft .....	C3

## CHASSIS

Frame .....	C4
Fender .....	C5
Side Cover .....	C6
Rear Arm .....	C7~C8
Rear Suspension .....	C9
Steering .....	C10
Front Fork .....	C11~C12
Fuel Tank .....	C13
Seat .....	C14
Front Wheel .....	C15
Front Brake Caliper .....	D2
Rear Wheel .....	D3~D4
Rear Brake Caliper .....	D5

Steering Handle. Cable .....	D6
Front Master Cylinder .....	D7
Stand. Footrest .....	D8
Rear Master Cylinder .....	D9
Generator .....	D10
Handle Switch. Lever .....	D11
Electrical 1 .....	D12

## ALTERNATE PARTS

Alternate (Chassis) .....	D13
---------------------------	-----

## REPAIR KIT

Repair Kit .....	D14
------------------	-----

## INDEX

Numerical Index .....	M1~M3
-----------------------	-------

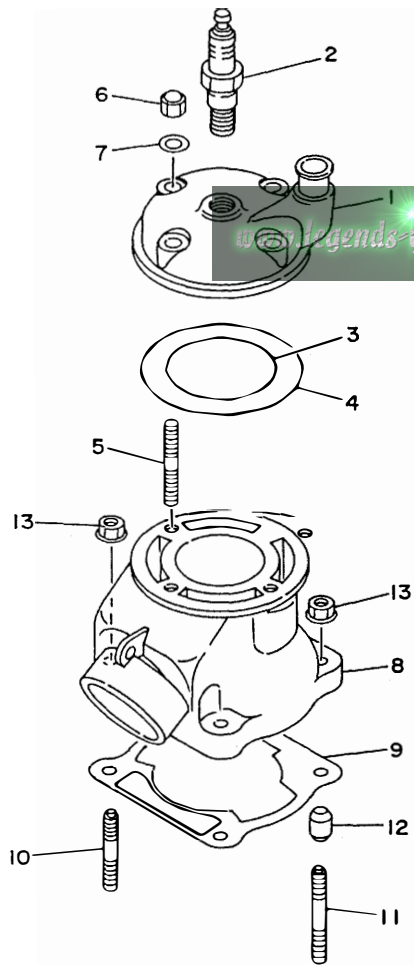

FIG. 1 CYLINDER

REF. NO.	PART NO.	DESCRIPTION	QTY	REMARKS
1	4LC-11111-00	HEAD, CYLINDER 1	1	
2	94702-00367	PLUG, SPARK (NGK B10EG)	1	UR-FOR-USA
	<del>94702-00368</del>	<del>PLUG, SPARK (NGK BR10EG)</del>	<del>1</del>	<del>UR</del>
3	93210-56459	O-RING	1	
4	93210-84724	O-RING	1	
5	90116-08394	BOLT, STUD	4	
6	90176-08026	NUT, CROWN	4	
7	90201-08087	WASHER, PLATE	4	
8	4ES-11311-10	CYLINDER 1	1	
9	4ES-11351-00	GASKET, CYLINDER	1	
10	90116-08318	BOLT, STUD	2	
11	90116-08388	BOLT, STUD	2	
12	99510-10114	PIN, DOWEL	2	
13	90179-08491	NUT	4	



4ES1100-3010

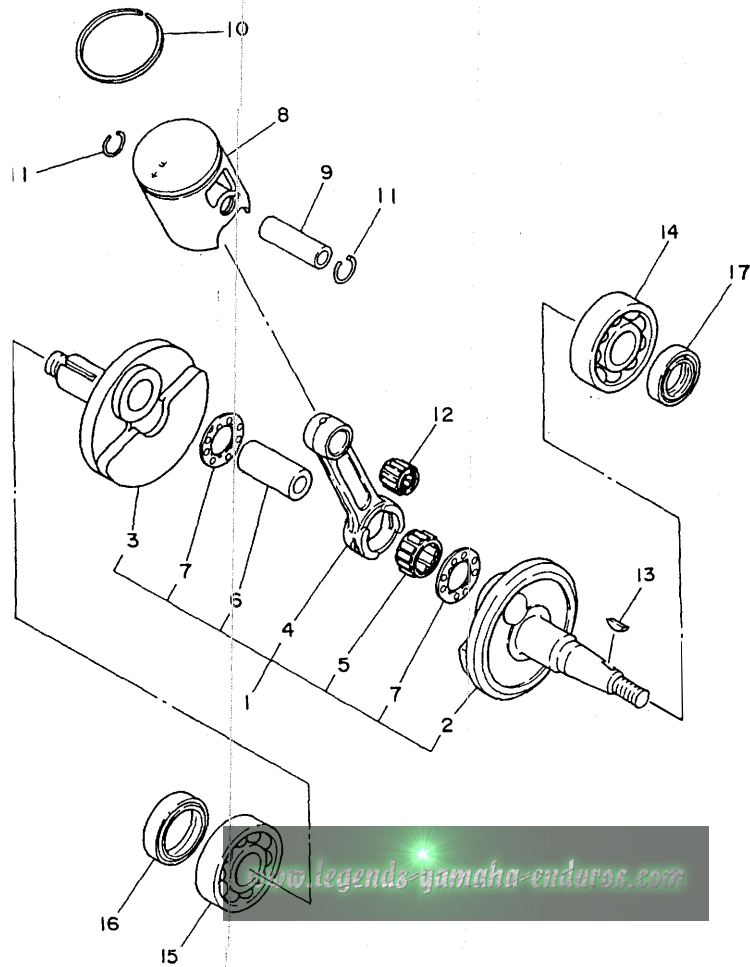

FIG. 2 CRANKSHAFT. PISTON

REF. NO.	PART NO.	DESCRIPTION	Q'TY	REMARKS
1	4ES-11400-02	CRANKSHAFT ASSY	1	
2	4ES-11412-00	.CRANK 1	1	
3	4ES-11422-00	.CRANK 2	1	
4	4ES-11651-01	.ROD, CONNECTING	1	
5	93310-320T3	.BEARING, CYLINDRICAL	1	
6	2RA-11681-00	.PIN, CRANK 1	1	
7	90209-20159	.WASHER	2	
8	4ES-11631-01-A0	PISTON (STD)	1	UR RED
	4ES-11631-01-B0	PISTON (STD)	1	UR ORANGE
	4ES-11631-01-C0	PISTON (STD)	1	UR GREEN
	4ES-11631-01-D0	PISTON (STD)	1	UR PURPLE
9	4ES-11633-00	PIN, PISTON	1	
10	43K-11611-00	RING, PISTON	1	
11	93450-16115	CIRCLIP	2	
12	93310-214F8	BEARING, CYLINDRICAL	1	KOYO
13	90280-03017	KEY, WOODRUFF	1	
14	93306-20468	BEARING	1	
15	93306-30421	BEARING (B6304C3)	1	
16	93103-28126	OIL SEAL	1	
17	93102-20447	OIL SEAL	1	

  
4ES1100-3020

**B3**



FIG. 3 WATER PUMP

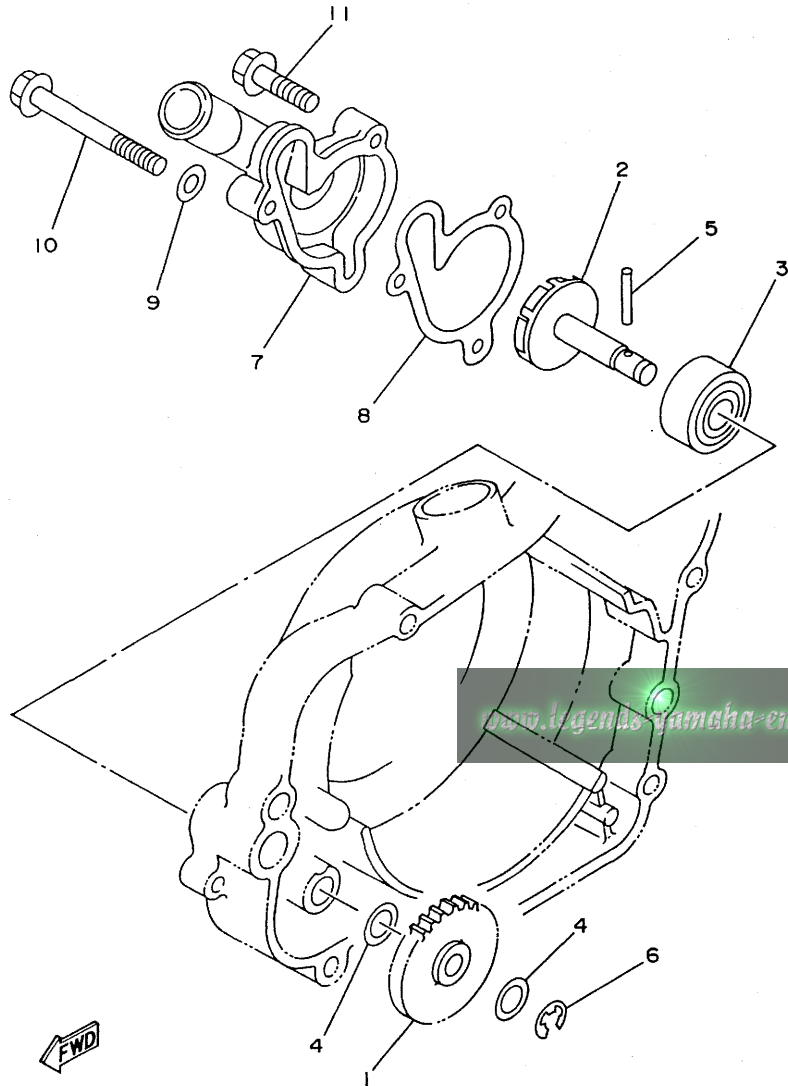

REF. NO.	PART NO.	DESCRIPTION	Q'TY	REMARKS
1	4ES-12459-00	GEAR, IMPELLER SHAFT	1	
2	36F-12450-00	IMPELLER SHAFT ASSY	1	
3	93103-10168	OIL SEAL	1	
4	90201-08512	WASHER, PLATE	2	
5	93603-22028	PIN, DOWEL	1	
6	99080-07600	CIRCLIP	1	
7	4BA-12422-00	COVER, HOUSING	1	
8	4BA-12428-00	GASKET, HOUSING COVER 2	1	
9	90430-06166	GASKET	1	
10	95827-06060	BOLT, FLANGE	1	
11	95027-06025	BOLT	2	



4ES1100-3030

**B4**

FIG. 4 RADIATOR. HOSE

REF. NO.	PART NO.	DESCRIPTION	Q'TY	REMARKS
1	4ES-12461-00	RADIATOR ASSY	1	
2	22W-12462-00	CAP, RADIATOR	1	
3	22W-12463-00	PIPE, BREATHER	1	
4	90467-08004	CLIP	1	
5	4ES-12481-00	PIPE 1	1	
6	4ES-12482-00	PIPE 2	1	
7	90450-28014	HOSE CLAMP ASSY	4	
8	90201-063J2	WASHER, PLATE	3	
9	95027-06030	BOLT	3	
10	90480-15528	GROMMET	3	
11	90387-0700G	COLLAR	3	
12	437-83936-01	BAND, SWITCH CORD	1	

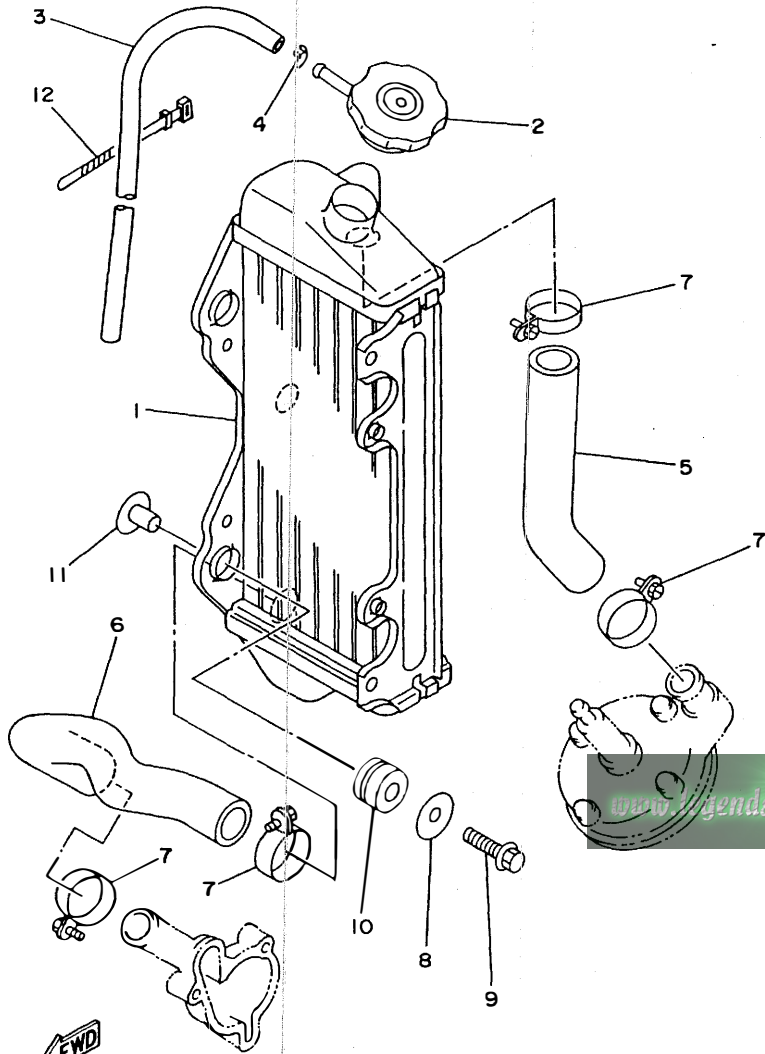

4ES1100-3040

FIG. 5 INTAKE

REF. NO.	PART NO.	DESCRIPTION	Q'TY	REMARKS
1	4ES-13610-00	REED VALVE ASSY	1	
2	4ES-13613-00	.REED, VALVE	2	
3	4ES-13616-00	.STOPPER, REED VALVE	2	
4	98507-03008	.SCREW, PAN HEAD	4	
5	92907-03100	.WASHER	4	
6	4ES-13565-00	JOINT, CARBURETOR	1	
7	95027-06020	BOLT, FLANGE	4	
8	90450-45075	CLAMP, HOSE	1	
9	90460-51059	CLAMP, HOSE	1	
10	4ES-14453-00	JOINT, AIR CLEANER 1	1	
11	4ES-14459-00	HOLDER, GUIDE	1	
12	4ES-14462-00	.SEAL	1	
13	97707-50014	SCREW, TAPPING	5	
14	90450-99064	HOSE CLAMP ASSY	1	
15	4ES-14411-01	CASE, AIR CLEANER 1	1	
16	4ES-14417-00	.COVER 1	1	
17	90267-40077	.RIVET, BLIND	2	
18	90201-047A2	.WASHER, PLATE	2	
19	92907-04600	.WASHER	2	
20	4ES-14451-00	ELEMENT, AIR CLEANER	1	
21	4ES-14458-00	GUIDE	1	
22	90209-06096	WASHER	1	
23	90122-06038	BOLT, WING	1	
24	90464-16039	CLAMP	1	

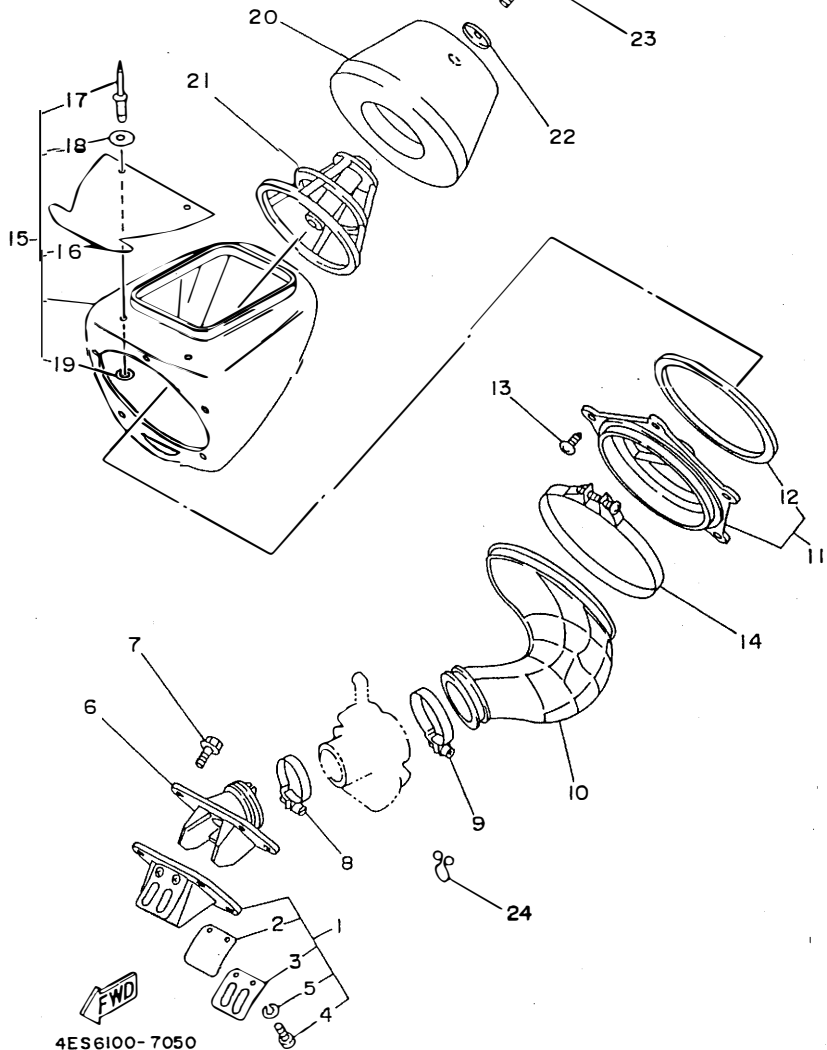

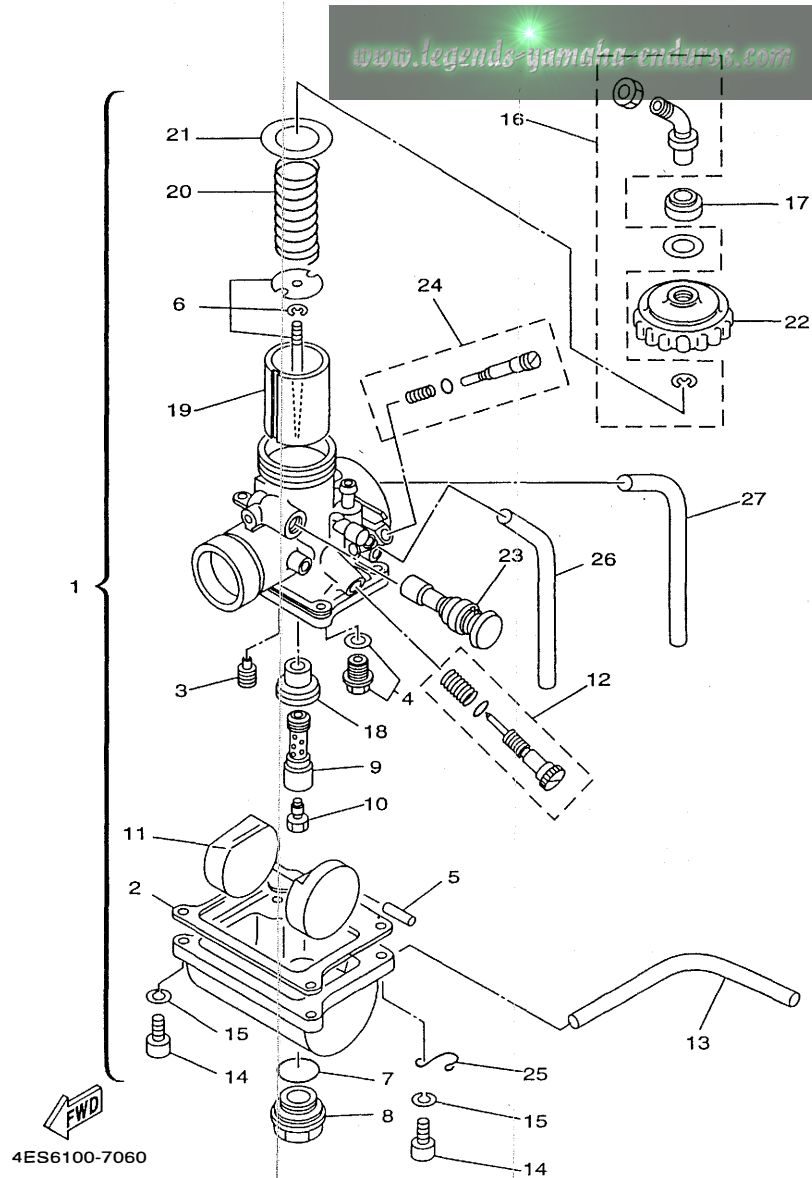

4ES6100-7060

FIG. 6 CARBURETOR

REF. NO.	PART NO.	DESCRIPTION	Q'TY	REMARKS
1	4ES-14101-10	CARBURETOR ASSY 1	1	
2	304-14184-00	.GASKET, FLOAT CHAMBER	1	
3	260-14142-32	.JET, PILOT (#32.5)	1	STD
	260-14142-30	.JET, PILOT (#30)	1	AP
	260-14142-35	.JET, PILOT (#35)	1	AP
4	23L-14107-25	.NEEDLE VALVE SET	1	
5	127-14186-00	.PIN, FLOAT	1	
6	58T-1490J-00	.NEEDLE SET	1	
7	93210-18288	.O-RING	1	
8	3R1-14115-00	.PLUG, SCREW	1	
9	3R1-14141-52	.NOZZLE, MAIN	1	STD
	3R1-14141-50	.NOZZLE, MAIN	1	AP
	3R1-14141-54	.NOZZLE, MAIN	1	AP
10	137-14143-60-A0	.JET, MAIN (#300)	1	STD
	137-14143-58-A1	.JET, MAIN (#290)	1	AP
	137-14143-62-A0	.JET, MAIN (#310)	1	AP
11	314-14185-00	.FLOAT	1	
12	31J-14103-00	.THROTTLE SCREW SET	1	
13	278-14197-00	.PIPE	1	
14	98507-04018	.SCREW, PAN HEAD	4	
15	92907-04100	.WASHER, SPRING	4	
16	22W-14106-00	.CABLE ADJUST SCREW SET	1	
17	3X3-14169-00	.CAP	1	
18	39K-14153-00	.WASHER, MAIN JET	1	
19	2X6-14112-30	.VALVE, THROTTLE 1	1	STD
	2X6-14112-25	.VALVE, THROTTLE 1	1	AP
	2X6-14112-35	.VALVE, THROTTLE 1	1	AP
20	248-14131-00	.SPRING, THROTTLE VALVE	1	

**B7**

FIG. 6 CARBURETOR

REF. NO.	PART NO.	DESCRIPTION	QTY	REMARKS
21	2A6-14126-00	.GASKET	1	
22	2A6-14158-00	.TOP, MIXING CHAMBER	1	
23	3SB-14171-00	.PLUNGER, STARTER	1	
24	10W-14104-00	.AIR SCREW SET	1	
25	25G-14937-00	.CLIP	2	
26	3JN-14196-00	.PIPE	1	
27	3Y1-14197-00	.PIPE	1	

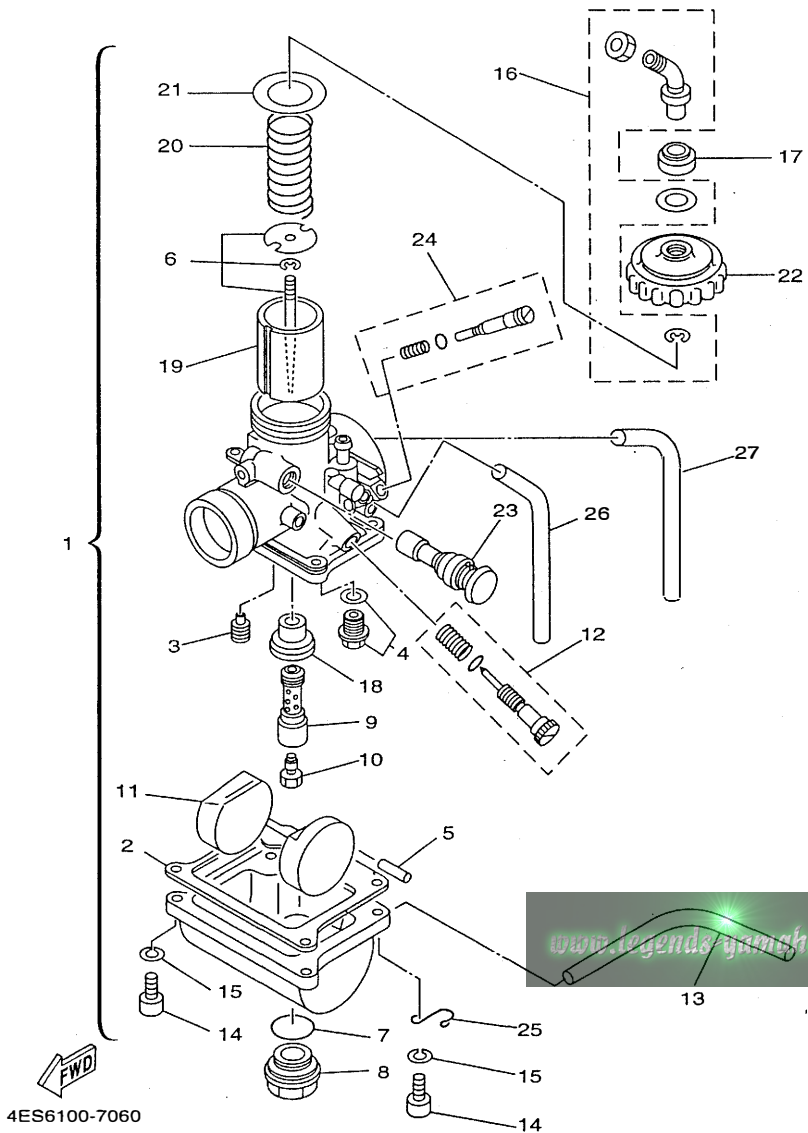

FWD  
4ES6100-7060

**B8**

FIG. 7 EXHAUST

REF. NO.	PART NO.	DESCRIPTION	Q'TY	REMARKS
1	4ES-14610-10	EXHAUST PIPE ASSY 1	1	
2	90201-33299	WASHER, PLATE	1	
3	90480-18411	GROMMET	1	
4	90387-105L0	COLLAR	1	
5	90201-060A3	WASHER, PLATE	1	
6	95027-06025	BOLT	1	
7	93210-371A9	O-RING	1	
8	90507-20030	SPRING, TENSION	1	
9	565-14771-00	STAY, MUFFLER 1	1	
10	95027-06012	BOLT	2	
11	4ES-14753-00	SILENCER, EXHAUST	1	
12	4ES-1469A-00	.FIBER	1	
13	90480-16561	GROMMET	1	
14	90387-063G3	COLLAR	1	
15	95027-06025	BOLT	1	
16	17W-14615-00	JOINT, EXHAUST 1	1	

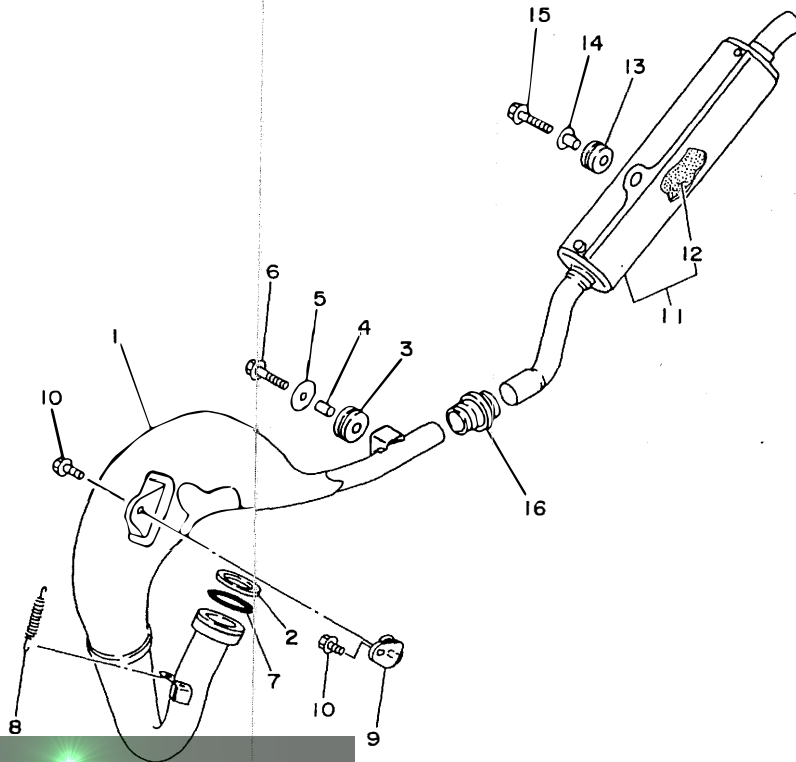

[www.legends-yamaha-enduro.com](http://www.legends-yamaha-enduro.com)



4ES3100-4070

**B9**

FIG. 8 CRANKCASE

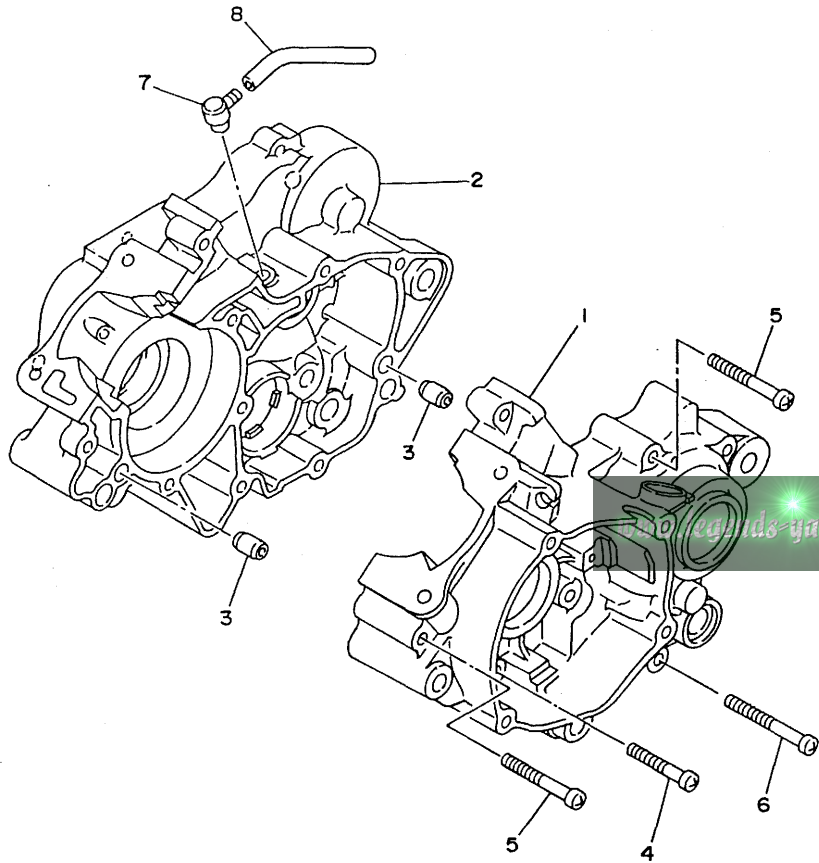

REF. NO.	PART NO.	DESCRIPTION	Q'TY	REMARKS
1	4ES-15111-00	CRANKCASE 1	1	
2	4ES-15121-01	CRANKCASE 2	1	
3	99530-10014	PIN, DOWEL	2	
4	98507-06040	SCREW, PAN HEAD	3	
5	98507-06050	SCREW, PAN HEAD	5	
6	98507-06060	SCREW, PAN HEAD	3	
7	583-15371-00	BREATHER	1	
8	90446-07349	HOSE	1	



4ES1100-3080

**B10**

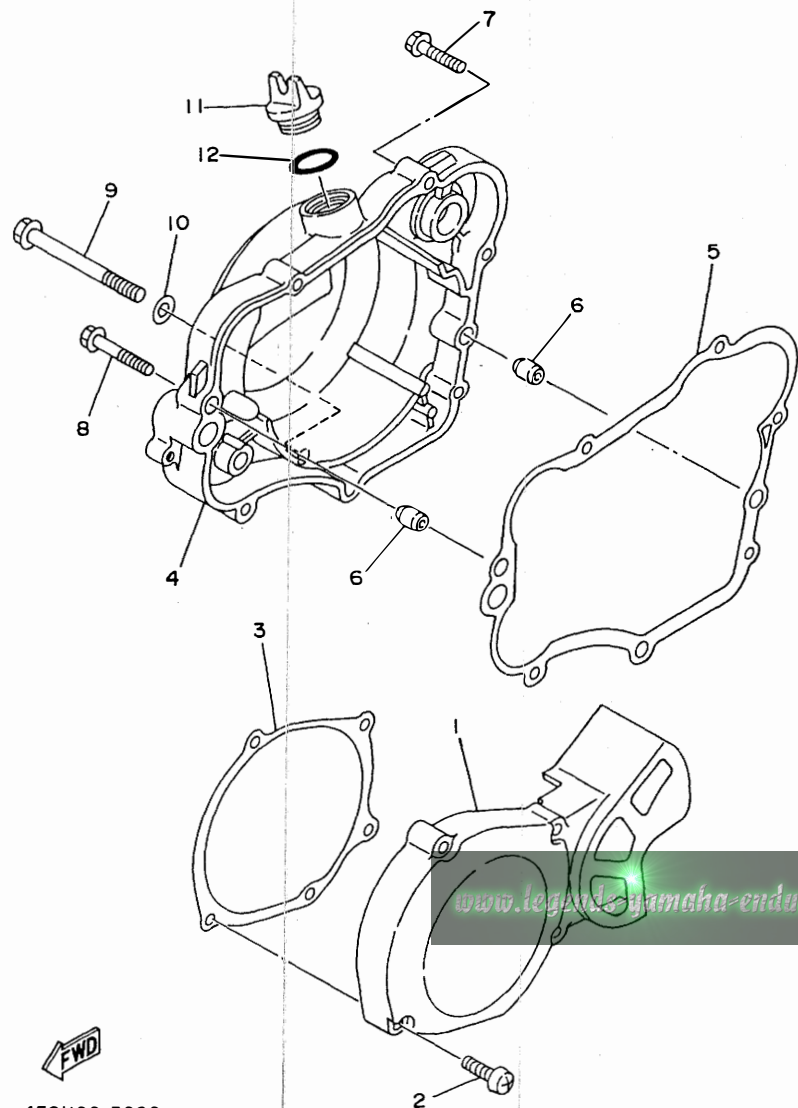

FIG. 9 CRANKCASE COVER 1

REF. NO.	PART NO.	DESCRIPTION	Q'TY	REMARKS
1	4ES-15411-00	COVER, CRANKCASE 1	1	
2	98507-06030	SCREW, PAN HEAD	4	
3	4ES-15451-00	GASKET, CRANKCASE COVER 1	1	
4	4ES-15421-01	COVER, CRANKCASE 2	1	
5	4ES-15461-00	GASKET, CRANKCASE COVER 2	1	
6	99530-10014	PIN, DOWEL	2	
7	95027-06030	BOLT, FLANGE	4	
8	95027-06040	BOLT, FLANGE	1	
9	95027-08080	BOLT, FLANGE	1	
10	90201-08087	WASHER, PLATE	1	
11	1RG-15363-00	PLUG, OIL	1	
12	93210-19123	O-RING	1	

[www.legends-yamaha-enduros.com](http://www.legends-yamaha-enduros.com)



4ES1100-3090

**B11**



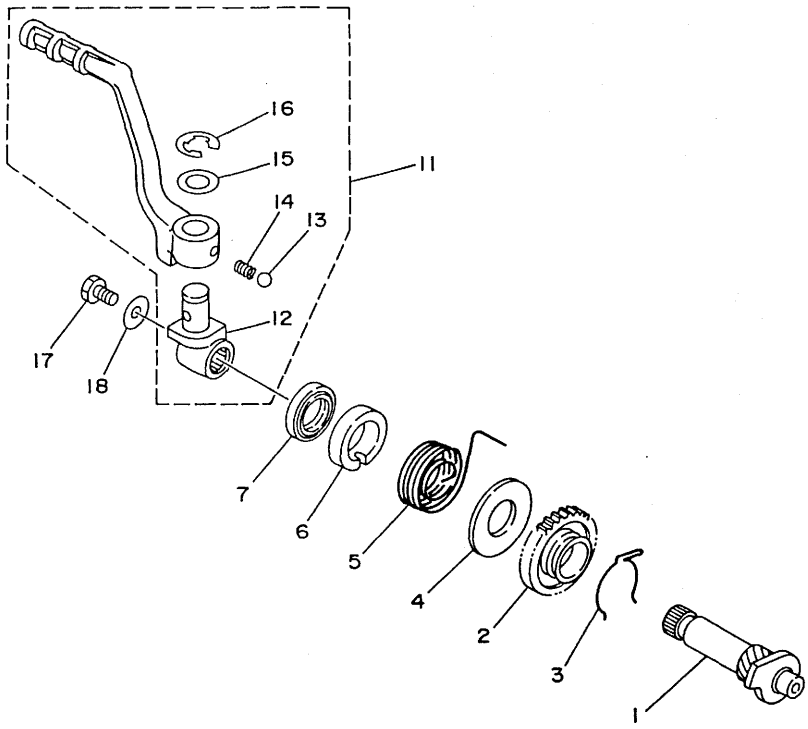
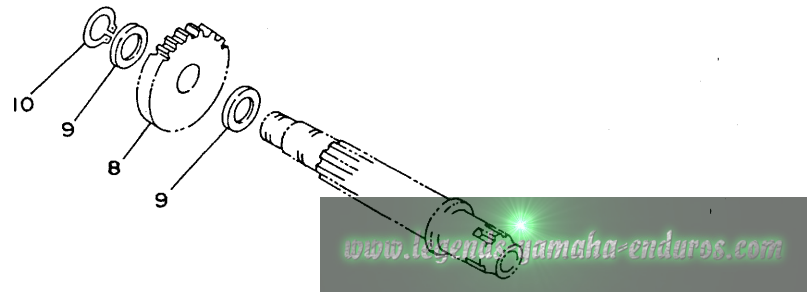

FIG. 10 STARTER

REF. NO.	PART NO.	DESCRIPTION	Q'TY	REMARKS
1	4ES-15660-00	KICK AXLE ASSY	1	
2	4ES-15641-00	GEAR, KICK	1	
3	90468-23194	CLIP	1	
4	90201-176L4	WASHER, PLATE	1	
5	90508-26750	SPRING, TORSION	1	
6	4ES-15664-00	GUIDE, SPRING	1	
7	93102-17263	OIL SEAL	1	
8	4ES-15651-00	GEAR, KICK IDLE	1	
9	90201-124F8	WASHER, PLATE	2	
10	99009-12400	CIRCLIP	1	
11	4ES-15620-00	KICK CRANK ASSY	1	
12	4ES-15621-00	.BOSS, KICK CRANK	1	
13	93507-32031	.BALL	1	
14	90501-12081	.SPRING, COMPRESSION	1	
15	90201-12631	.WASHER, PLATE	1	
16	93430-08007	.CIRCLIP	1	
17	95027-06012	BOLT	1	
18	90201-065F3	WASHER, PLATE	1	



4ES1100-3100



**B12**

FIG. 11 CLUTCH

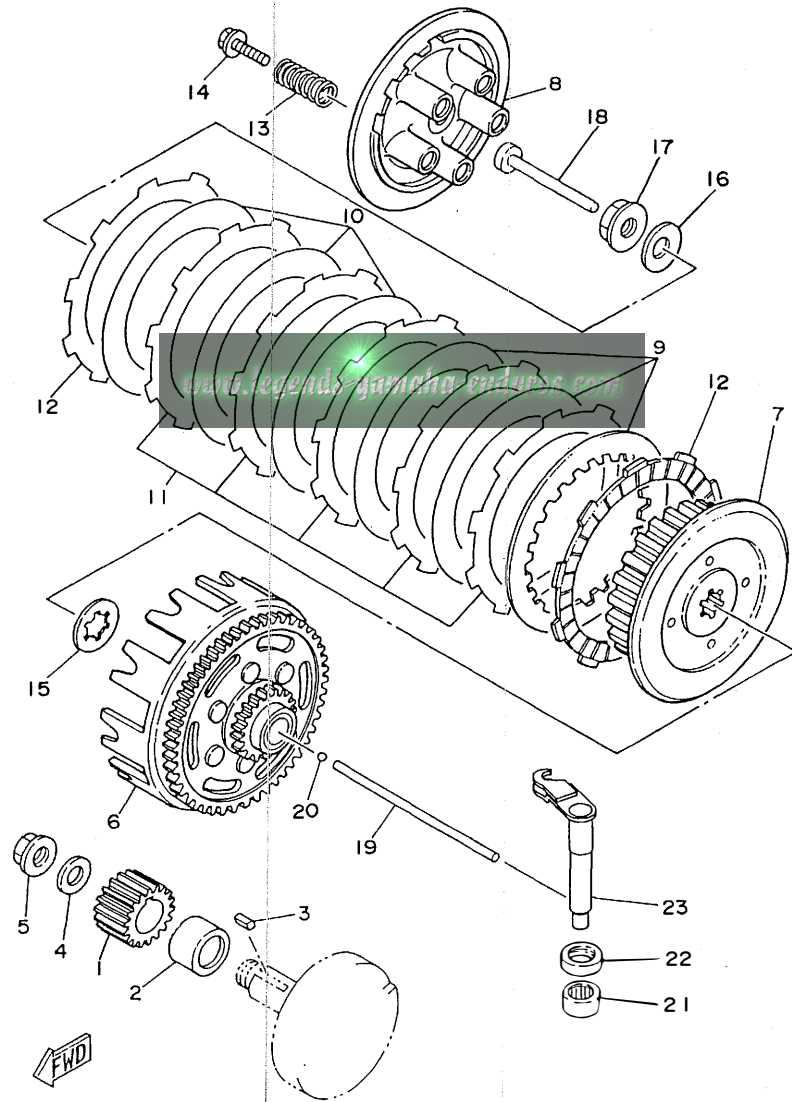

REF. NO.	PART NO.	DESCRIPTION	Q'TY	REMARKS
1	4ES-16111-00	GEAR, PRIMARY DRIVE	1	
2	90387-20488	COLLAR	1	
3	90282-05001	KEY, STRAIGHT	1	
4	90208-12015	WASHER, CONICAL SPRING	1	
5	90179-12659	NUT	1	
6	4ES-16150-11	PRIMARY DRIVEN GEAR COMP.	1	
7	37F-16371-01	BOSS, CLUTCH	1	
8	2TK-16351-00	PLATE, PRESSURE 1	1	
9	257-16324-00	PLATE, CLUTCH 1	3	
10	131-16324-00	PLATE, CLUTCH 1	3	
11	4ES-16321-00	PLATE, FRICTION	5	
12	21V-16321-00	PLATE, FRICTION	2	
13	90501-20735	SPRING, COMPRESSION	5	
14	90119-05001	BOLT, WITH WASHER	5	
15	4V0-16154-00	PLATE, THRUST 1	1	
16	90208-12015	WASHER, CONICAL SPRING	1	
17	90179-12659	NUT	1	
18	4ES-16356-00	ROD, PUSH 1	1	
19	2RA-16357-00	ROD, PUSH 2	1	
20	93503-16010	BALL	1	
21	93315-11206	BEARING, CYLINDRICAL	1	
22	93102-12224	OIL SEAL	1	
23	4ES-16381-00	PUSH LEVER COMP.	1	

4ES4100-5110

**B13**

FIG. 12 TRANSMISSION

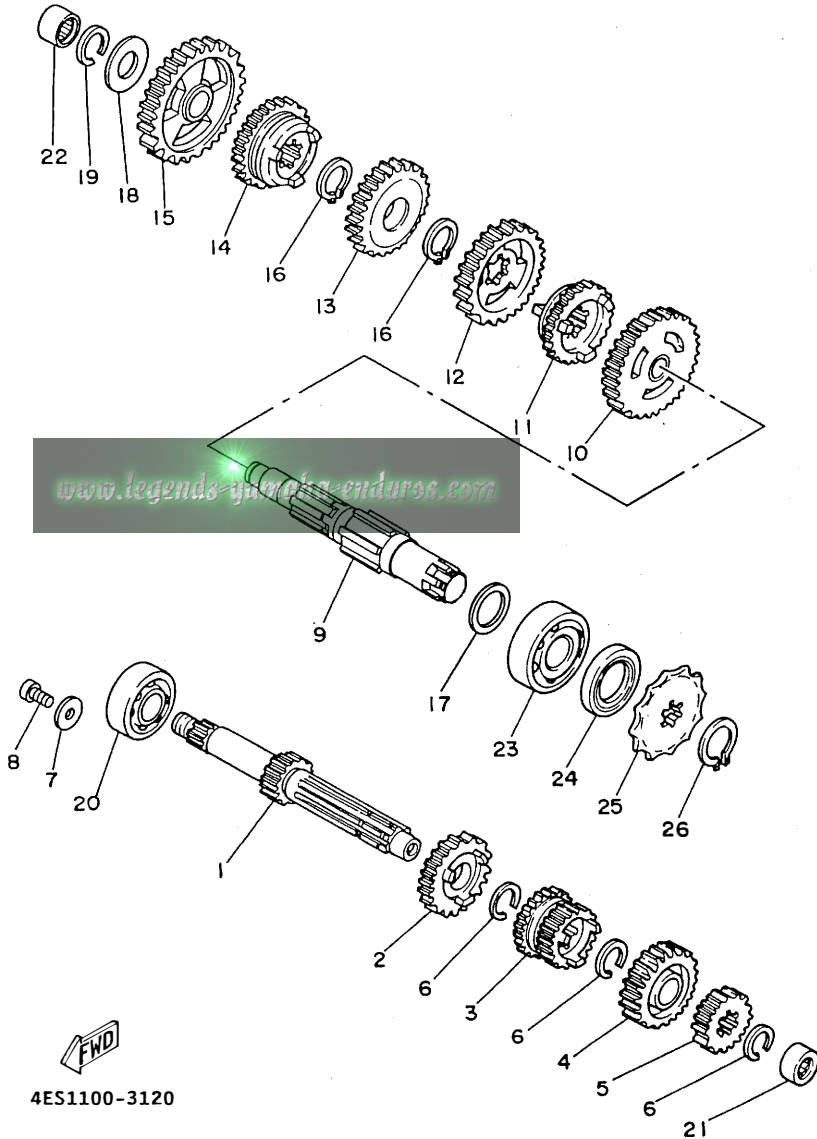

REF. NO.	PART NO.	DESCRIPTION	Q'TY	REMARKS
1	4ES-17411-01	AXLE, MAIN	1	
2	4ES-17151-00	GEAR, 5TH PINION	1	
3	4ES-17131-00	GEAR, 3RD PINION	1	
4	4ES-17161-00	GEAR, 6TH PINION	1	
5	4ES-17121-01	GEAR, 2ND PINION	1	
6	93440-17064	CIRCLIP	3	
7	90201-065F3	WASHER, PLATE	2	
8	90157-06071	SCREW, PAN HEAD	2	
9	4ES-17421-00	AXLE, DRIVE	1	
10	4ES-17221-01	GEAR, 2ND WHEEL	1	
11	4ES-17261-01	GEAR, 6TH WHEEL	1	
12	4ES-17231-01	GEAR, 3RD WHEEL	1	
13	4ES-17241-00	GEAR, 4TH WHEEL	1	
14	4ES-17251-00	GEAR, 5TH WHEEL	1	
15	4ES-17211-01	GEAR, 1ST WHEEL	1	
16	93410-20038	CIRCLIP	2	
17	90201-203E7	WASHER, PLATE	1	
18	164-17427-00-06	SHIM 1 (0.6T)	1	
19	93440-15012	CIRCLIP	1	
20	93306-20333	BEARING	1	
21	93317-11245	BEARING, CYLINDRICAL	1	
22	93315-31502	BEARING, CYLINDRICAL	1	
23	93306-20421	BEARING (B6204)	1	
24	93102-20143	OIL SEAL	1	
25	93822-14037	SPROCKET, DRIVE 14T (1741746140)	1	STD
	93822-12012	SPROCKET, DRIVE 12T (1741746120)	1	AP
	93822-13024	SPROCKET, DRIVE 13T (1741746130)	1	STD YZ200LW MODEL
	93822-15065	SPROCKET, DRIVE 15T (1741746150)	1	AP

4ES1100-3120

**B14**

FIG. 12 TRANSMISSION

REF. NO.	PART NO.	DESCRIPTION	Q'TY	REMARKS
26	99009-18400	CIRCLIP	1	

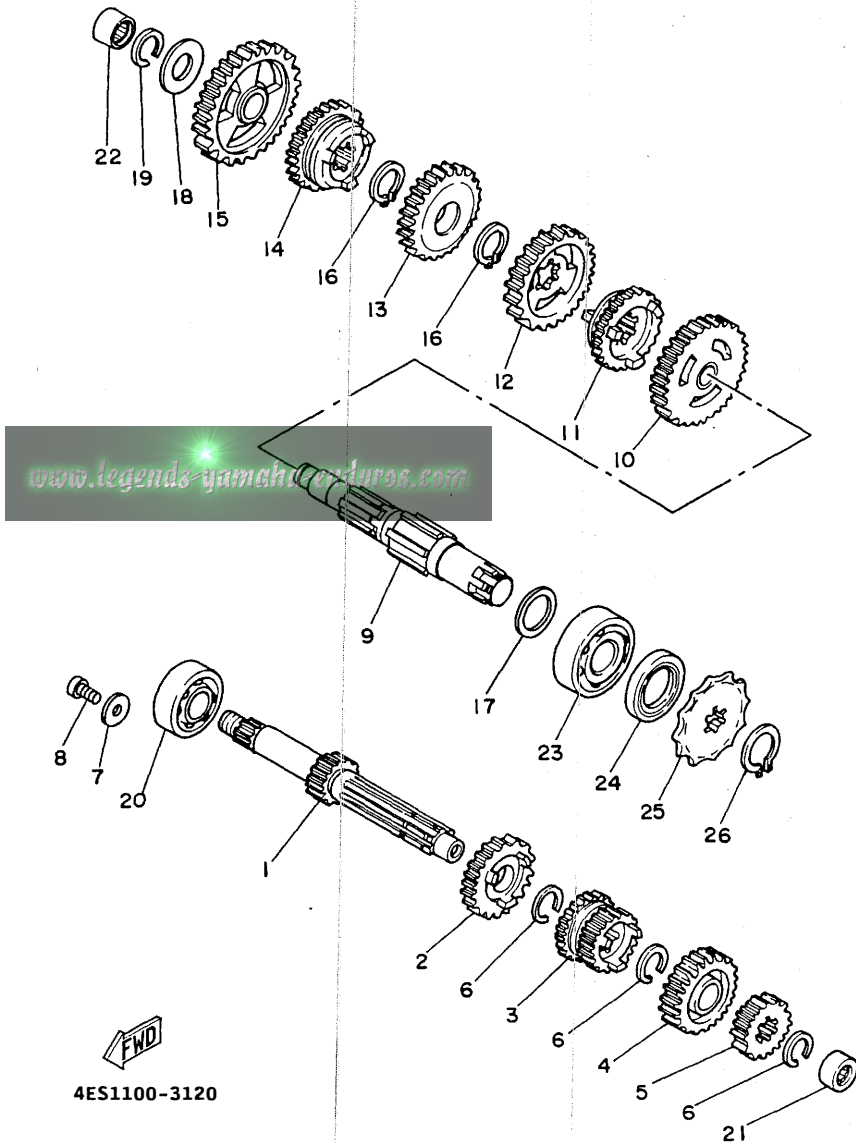

  
4ES1100-3120

**B15**

FIG. 13 SHIFT CAM. FORK

REF. NO.	PART NO.	DESCRIPTION	Q'TY	REMARKS
1	4ES-18540-00	SHIFT CAM ASSY	1	
2	4ES-18511-01	FORK, SHIFT 1	1	
3	4V0-18512-00	FORK, SHIFT 2	1	
4	4ES-18513-01	FORK, SHIFT 3	1	
5	90250-06013	PIN, STRAIGHT	3	
6	4BA-18531-00	BAR, SHIFT FORK GUIDE 1	1	
7	4BA-18535-00	BAR, SHIFT FORK GUIDE 2	1	
8	99009-10400	CIRCLIP	1	

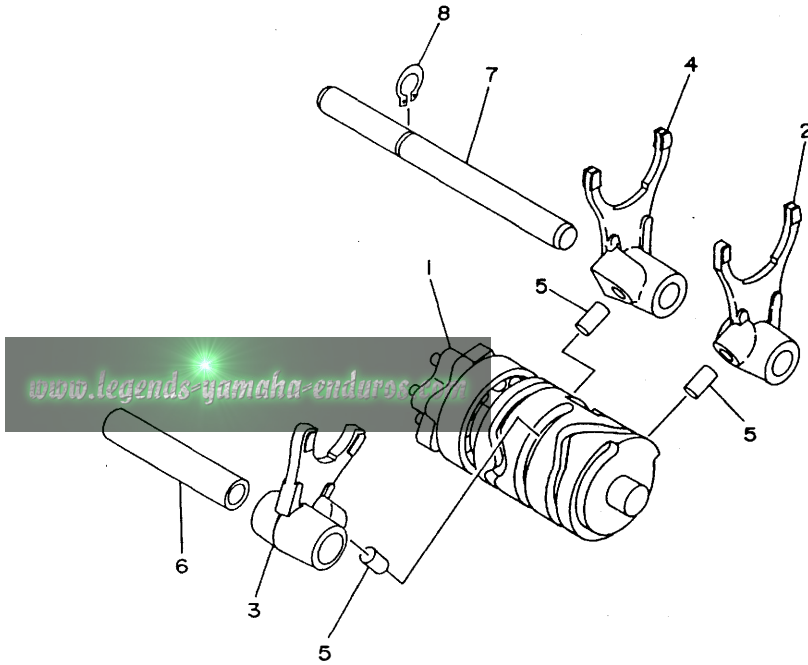

4ES3100-4130

C2

FIG. 14 SHIFT SHAFT

REF. NO.	PART NO.	DESCRIPTION	Q'TY	REMARKS
1	4ES-18101-00	SHIFT SHAFT ASSY	1	
2	90508-32553	SPRING, TORSION	1	
3	90508-242A6	SPRING, TORSION	1	
4	90387-126Y7	COLLAR	1	
5	99006-10600	CIRCLIP	3	
6	4BA-18140-00	STOPPER LEVER ASSY	1	
7	93101-12060	OIL SEAL	1	
8	2HF-18110-01	SHIFT PEDAL ASSY	1	
9	97027-06020	BOLT	1	

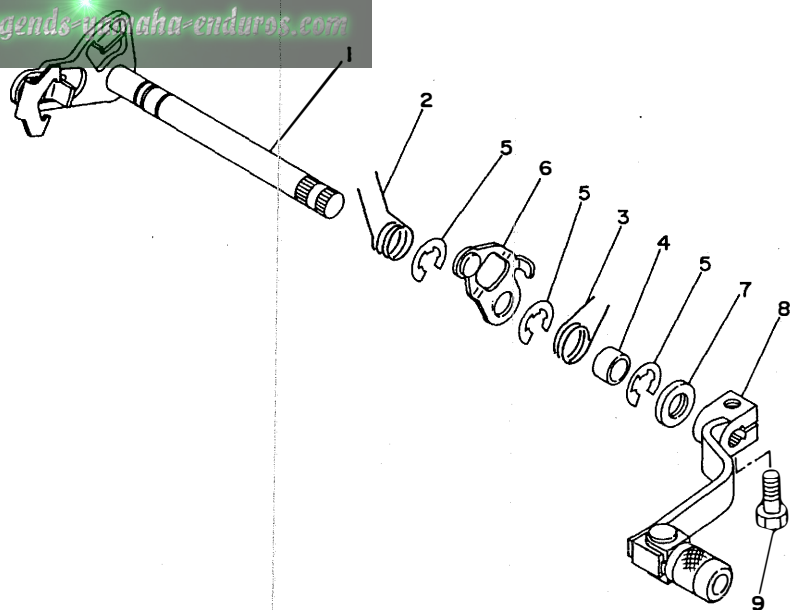

4ES1100-3140

C3

FIG. 15 FRAME

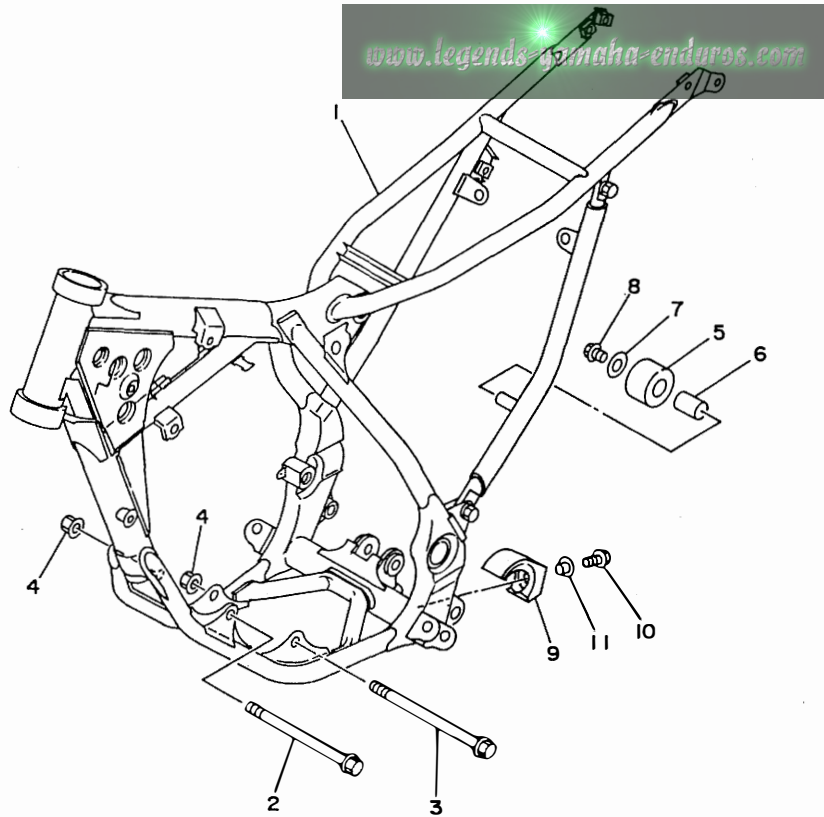

REF. NO.	PART NO.	DESCRIPTION	QTY	REMARKS
1	4ES-21110-01-2F	FRAME COMP.	1	STRONG BLUE
2	95817-08125	BOLT, FLANGE	1	
3	95817-08135	BOLT, FLANGE	1	
4	95607-08200	NUT, SELF-LOCKING	2	
5	30X-22178-00	TENSIONER	1	
6	4V4-22184-00	BUSH	1	
7	90201-081R9	WASHER, PLATE	1	
8	95027-08012	BOLT	1	
9	4ES-22178-00	TENSIONER	1	
10	90119-06118	BOLT, WITH WASHER	1	
11	90387-06216	COLLAR	1	



4ES1100-3150

**C4**

FIG. 16 FENDER

REF. NO.	PART NO.	DESCRIPTION	Q'TY	REMARKS
1	4ES-21511-10	FENDER, FRONT	1	
2	90119-06063	BOLT, WITH WASHER	4	
3	90209-06187	WASHER	4	
4	4ES-21611-00	FENDER, REAR	1	
5	95027-06016	BOLT	4	
6	90387-064X4	COLLAR	4	
7	4ES-21642-00	GUARD, FLAP	1	
8	90119-06185	BOLT, WITH WASHER	2	
9	36V-28371-00	DAMPER	1	YZ80LW-MODEL

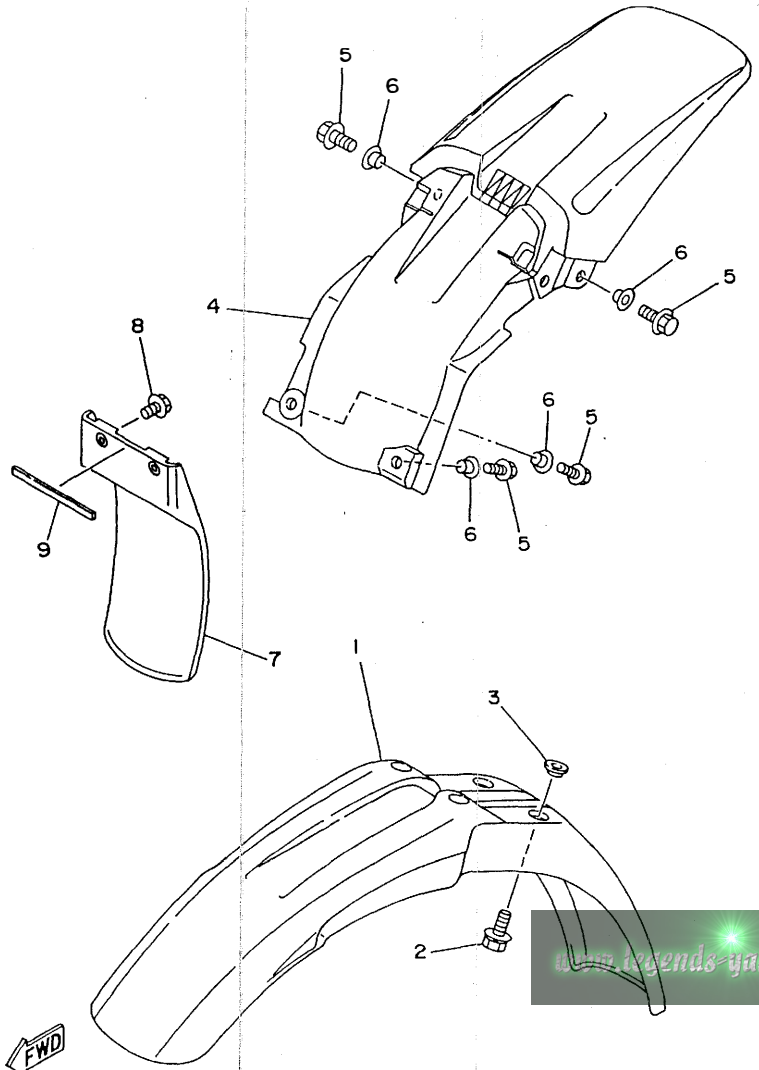

4ES4100-5160

C5



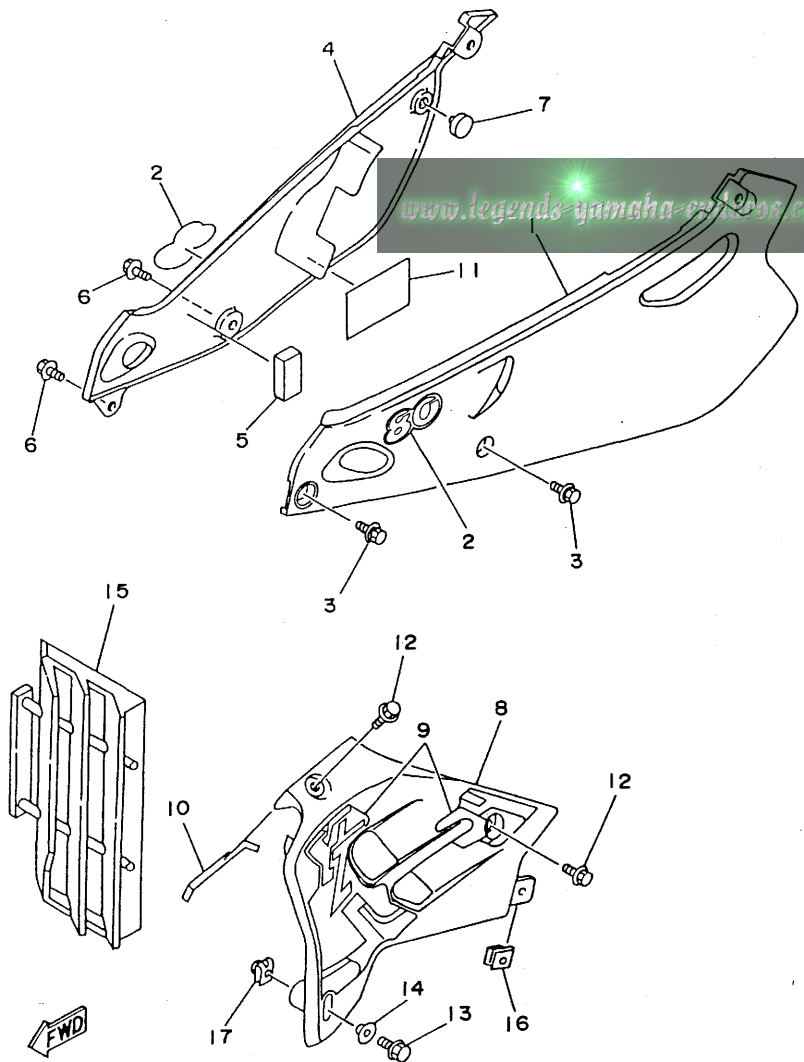
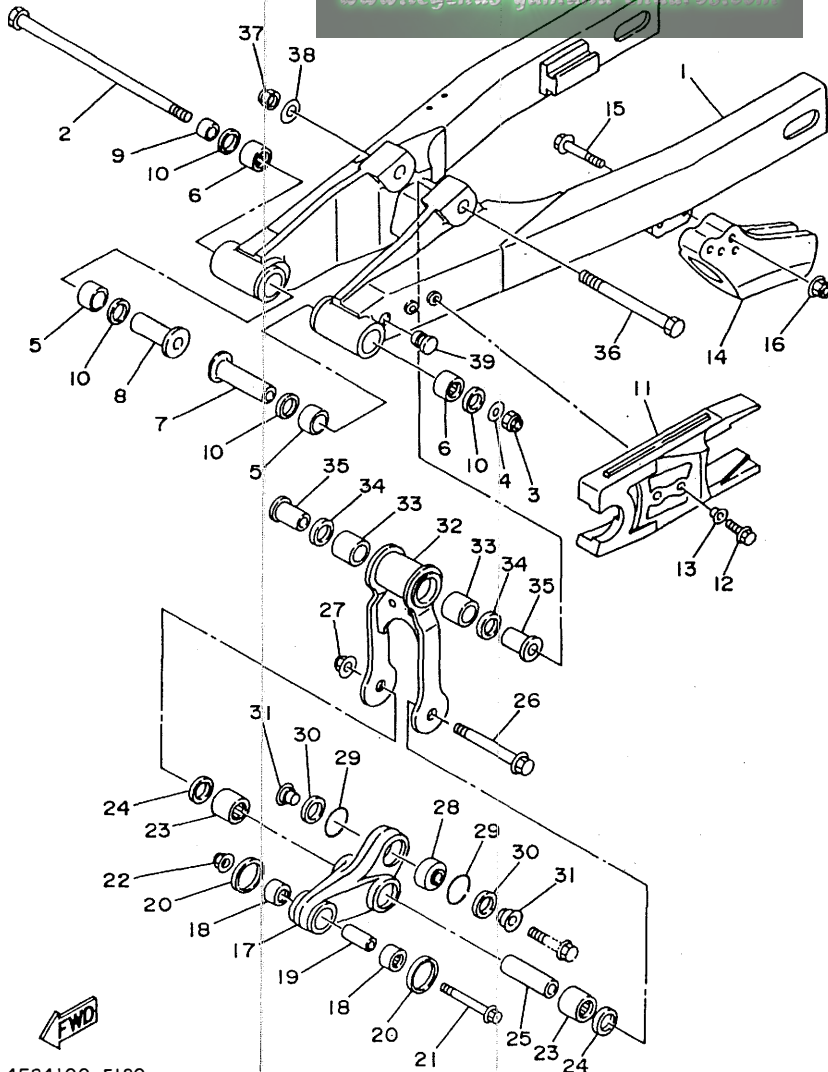

FIG. 17 SIDE COVER

REF. NO.	PART NO.	DESCRIPTION	Q'TY	REMARKS
1	4ES-21711-00	COVER, SIDE 1	1	
2	4ES-21781-00	EMBLEM 1	2	
3	90119-06217	BOLT, WITH WASHER	2	
4	4ES-21721-00	COVER, SIDE 2	1	
5	4ES-21735-00	SEAL 2	1	
6	90119-06217	BOLT, WITH WASHER	2	
7	22W-24181-00	DAMPER, LOCATING 1	1	
8	4ES-21731-10	COVER, SIDE 3	1	
9	4ES-21790-00	EMBLEM SET	1	
10	4ES-21732-00	SEAL 1	1	
11	4DJ-2174A-00	INSULATOR, SIDE COVER	1	
12	90109-067F4	BOLT	2	
13	95027-06016	BOLT, FLANGE	1	
14	90387-062M9	COLLAR	1	
15	4EW-2172A-10	PANEL 1	1	
16	90183-06023	NUT, SPRING	1	
17	90183-06069	NUT, SPRING	1	

4ES6100-7170

www.legends-yamaha-enturos.com



4ES4100-5180

FIG. 18 REAR ARM

REF. NO.	PART NO.	DESCRIPTION	Q'TY	REMARKS
1	4ES-22110-00	REAR ARM COMP.	1	UR
	4LB-22110-00	REAR ARM COMP.	1	UR-YZ80LW-MODEL
2	22W-25181-01	AXLE, WHEEL	1	
3	95617-12100	NUT, U	1	
4	90201-12469	WASHER, PLATE	1	
5	90385-17042	BUSH	2	
6	93317-21746	BEARING, CYLINDRICAL	2	
7	90387-127J8	COLLAR	1	
8	90387-127J7	COLLAR	1	
9	90387-1200U	COLLAR	1	
10	93109-17048	OIL SEAL (SDO 17-24-4)	4	
11	4ES-22151-00	SEAL, GUARD	1	
12	95027-06014	BOLT, FLANGE	2	
13	90387-062X0	COLLAR	2	
14	39K-22199-00	SUPPORT, CHAIN	1	
15	90105-08310	BOLT, WASHER BASED	2	
16	95607-08200	NUT, SELF-LOCKING	2	
17	4ES-2217A-00	ARM, RELAY	1	
18	93315-21455	BEARING, CYLINDRICAL	2	
19	90380-10218	BUSH, SOLID	1	
20	4ES-22129-00	COVER, THRUST 2	2	
21	90105-10582	BOLT, WASHER BASED	1	
22	95607-10200	NUT, SELF-LOCKING	1	
23	93317-31771	BEARING, CYLINDRICAL	2	
24	93101-17062	OIL SEAL	2	
25	90380-12219	BUSH, SOLID	1	
26	90105-12382	BOLT, WASHER BASED	1	
27	95607-12200	NUT, SELF-LOCKING	1	

C7

www.legends-yamaha-riders.com

FIG. 18 REAR ARM

REF. NO.	PART NO.	DESCRIPTION	Q'TY	REMARKS
28	93399-99921	BEARING	1	
29	93440-30113	CIRCLIP	2	
30	3XJ-22475-00	SEAL, DUST	2	
31	90387-103X9	COLLAR	2	
32	4ES-2217F-00	ROD, CONNECTING 1	1	
33	93317-31771	BEARING, CYLINDRICAL	2	
34	93101-17062	OIL SEAL	2	
35	90381-12091	BUSH, SOLID	2	
36	90101-12755	BOLT	1	
37	90185-12119	NUT, SELF-LOCKING	1	
38	90201-12749	WASHER, PLATE	1	
39	90338-10150	PLUG	2	

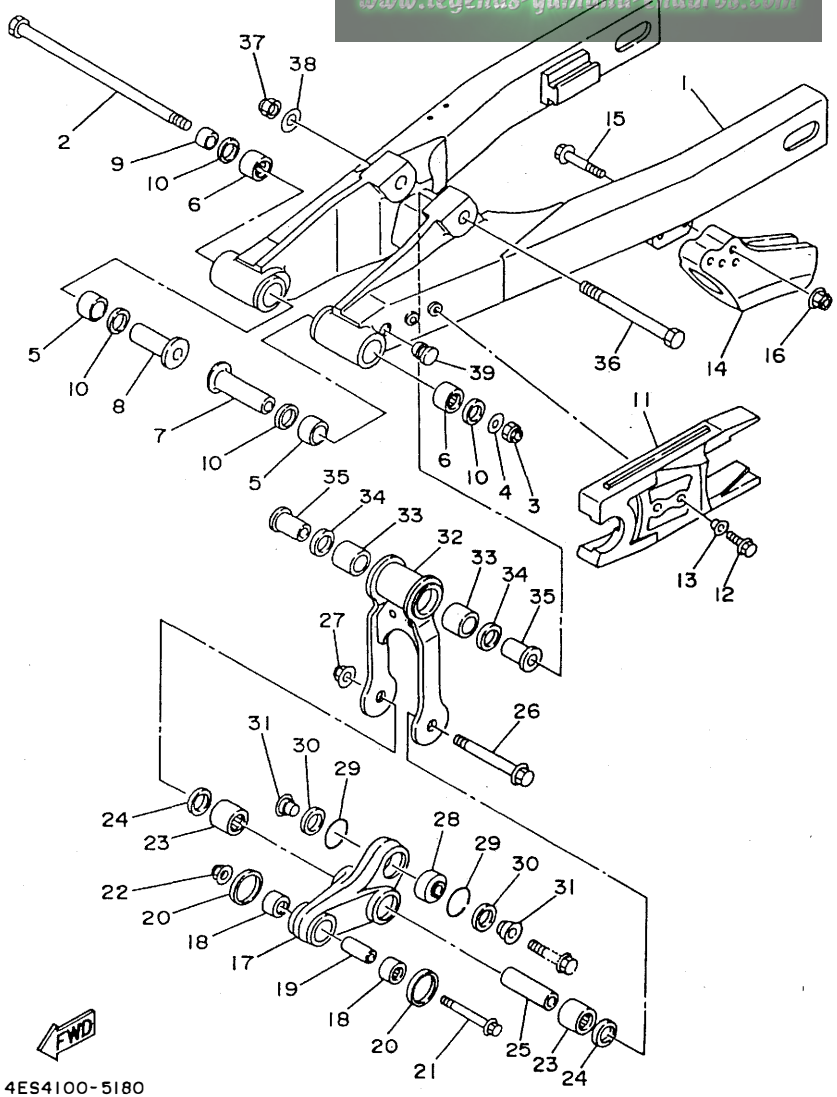

4ES4100-5180

C8

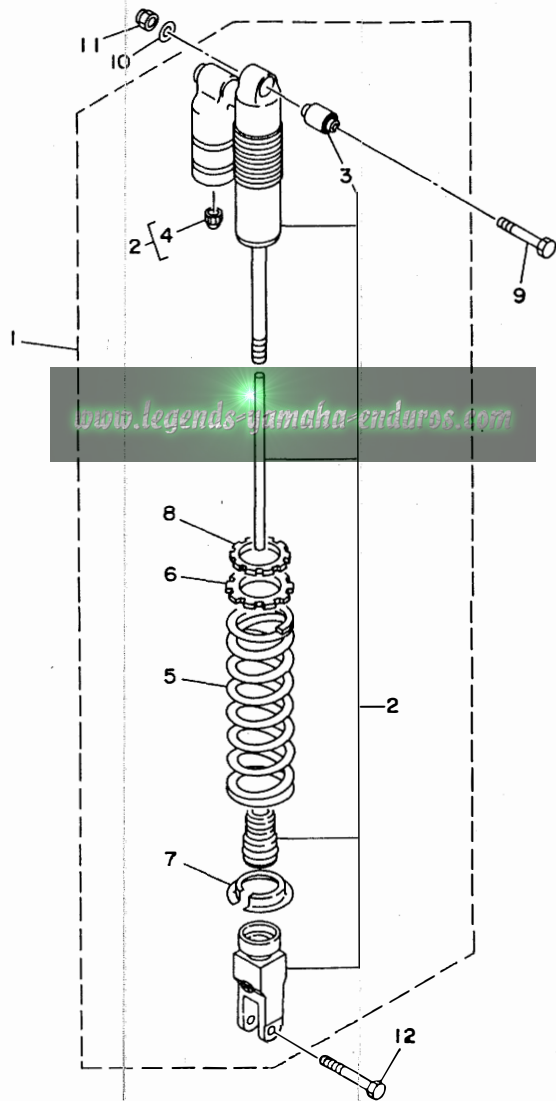

FIG. 19 REAR SUSPENSION

REF. NO.	PART NO.	DESCRIPTION	Q'TY	REMARKS
1	4ES-22210-90	SHOCK-ABSORBER ASSY, REAR	1	UR FOR USA
	4ES-22210-A0	SHOCK-ABSORBER ASSY, REAR	1	UR FOR CANADA
	4ES-22210-B0	SHOCK ABSORBER ASSY, REAR	1	UR FOR NEWZEALAND, S.AFRICA, EUROPE
	4LB-22210-40	SHOCK-ABSORBER ASSY, REAR	1	UR YZ80LW-MODEL
2	4ES-22201-30	DAMPER SUB ASSY	1	UR FOR USA
	4ES-22201-40	DAMPER SUB ASSY	1	UR FOR CANADA
	4ES-22201-50	DAMPER SUB ASSY	1	UR FOR NEWZEALAND, S.AFRICA, EUROPE
	4LB-22201-40	DAMPER SUB ASSY	1	UR YZ80LW-MODEL
3	4ES-22216-00	BUSH, REAR SHOCK ABSORBER	1	
4	58T-23184-L0	CAP, AIR VALVE	1	
5	4ES-22212-B0	SPRING (K=5.0)	1	UR
	4ES-22212-D0	SPRING (K=5.2)	1	UR YZ80LW-MODEL
6	4ES-22214-00	GUIDE, SPRING 1	1	
7	3JD-22214-00	GUIDE, SPRING 1	1	
8	4ES-22251-00	NUT 1	1	
9	90109-10729	BOLT	1	
10	92907-10600	WASHER, PLATE	1	
11	90185-10120	NUT, SELF-LOCKING	1	
12	90105-10614	BOLT, WASHER BASED	1	



4ES1100-3190

C9

FIG. 20 STEERING

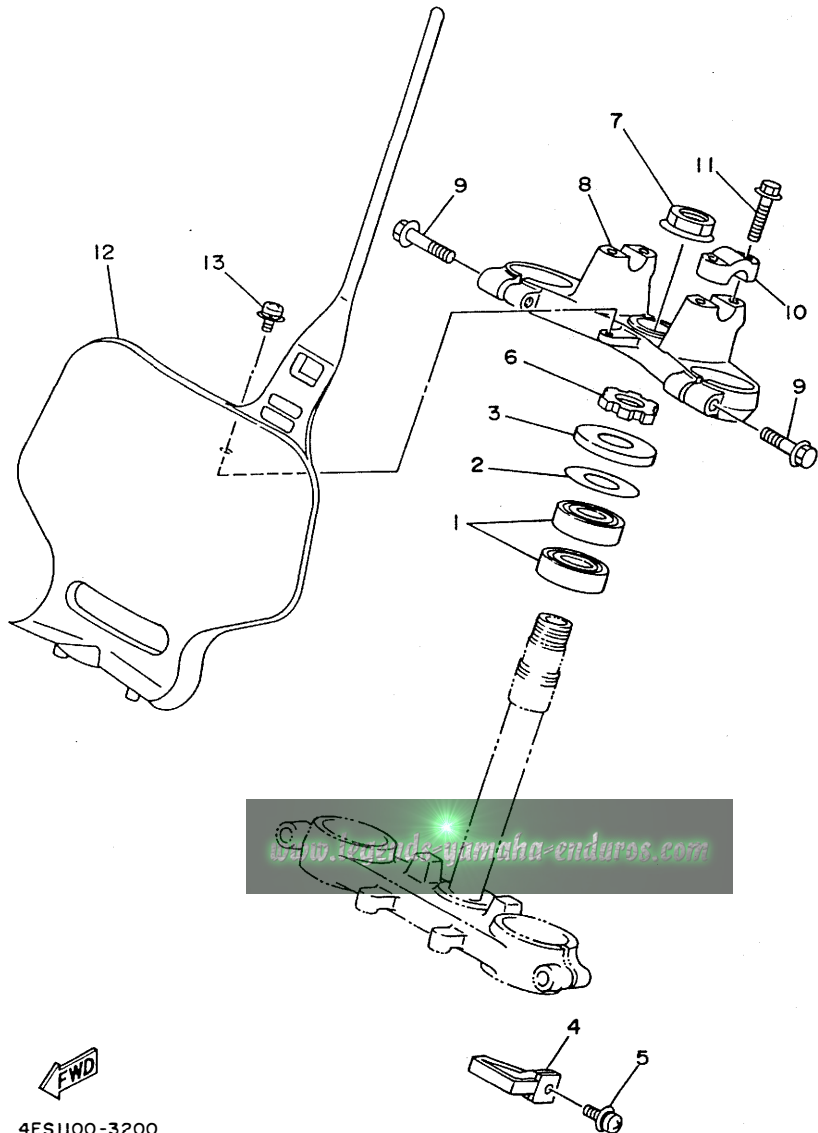

REF. NO.	PART NO.	DESCRIPTION	QTY	REMARKS
1	93332-00079	BEARING	2	
2	90201-256K5	WASHER, PLATE (0.5T)	1	
3	1J7-23415-00	COVER, BALL RACE 1	1	
4	4DA-23389-00	GUIDE, CABLE	1	
5	90157-05079	SCREW, PAN HEAD	1	
6	90179-25033	NUT	1	
7	90179-22412	NUT	1	
8	4ES-23435-00	CROWN, HANDLE	1	
9	95807-08035	BOLT, FLANGE	2	
10	3SP-23441-00	HOLDER, HANDLE UPPER	2	
11	95027-08030	BOLT, FLANGE	4	
12	4ES-23485-10	PLATE, NUMBER	1	
13	95027-06012	BOLT, FLANGE	1	



4ES1100-3200

C10

www.legends-yamaha-enduros.com

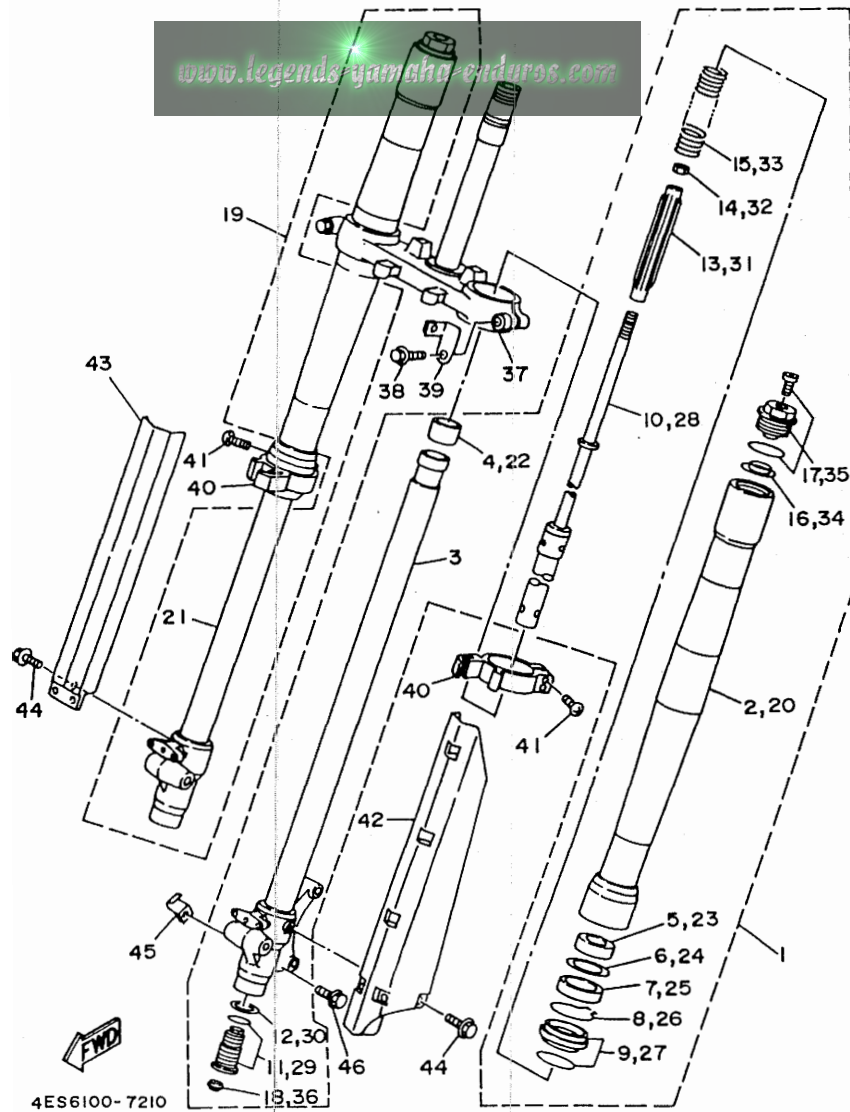

4ES6100-7210

FIG. 21 FRONT FORK

REF. NO.	PART NO.	DESCRIPTION	Q'TY	REMARKS
1	4ES-23102-20	FRONT FORK ASSY (L.H)	1	UR
	<del>4LB-23102-20</del>	<del>FRONT FORK ASSY (L.H)</del>	<del>1</del>	<del>UR-YZ80LW-MODEL</del>
2	4ES-23136-20	.TUBE, OUTER (RIGHT)	1	
3	4ES-23120-00	.INNER TUBE COMP. 2	1	
4	4ES-23171-00	.PISTON, FRONT FORK	1	
5	4ES-23125-00	.METAL, SLIDE 1	1	
6	5K5-23149-00	.WASHER, SPRING UPPER	1	
7	4ES-23145-00	.OIL SEAL	1	
8	4A1-23156-00	.CLIP, OIL SEAL	1	
9	4ES-23144-00	.SEAL, DUST	1	
10	4ES-23170-10	.CYLINDER COMP., FRONT FORK	1	
11	4ES-2316A-10	.VALVE COMP.	1	UR
	<del>4LB-2316A-20</del>	<del>.VALVE COMP.</del>	<del>1</del>	<del>UR-YZ80LW-MODEL</del>
12	2HH-23158-L0	.GASKET	1	
13	4ES-23142-00	.SEAT, SPRING UPPER	1	
14	3XJ-23357-L0	.NUT	1	
15	4ES-23141-40	.SPRING, FRONT FORK (K=0.29)	1	UR
	<del>4LB-23141-10</del>	<del>.SPRING, FRONT FORK (K=0.30)</del>	<del>1</del>	<del>UR-YZ80LW-MODEL</del>
16	4V4-23142-L0	.SEAT, SPRING UPPER	1	
17	4ES-23111-10	.BOLT, CAP	1	
18	3JD-23126-L0	.PLUG	1	
19	4ES-23103-20	FRONT FORK ASSY (R.H)	1	UR
	<del>4LB-23103-20</del>	<del>FRONT FORK ASSY (R.H)</del>	<del>1</del>	<del>UR-YZ80LW-MODEL</del>
20	4ES-23136-20	.TUBE, OUTER (RIGHT)	1	
21	4ES-23110-00	.INNER TUBE COMP. 1	1	
22	4ES-23171-00	.PISTON, FRONT FORK	1	
23	4ES-23125-00	.METAL, SLIDE 1	1	
24	5K5-23149-00	.WASHER, SPRING UPPER	1	

C11

FIG. 21 FRONT FORK

REF. NO.	PART NO.	DESCRIPTION	Q'TY	REMARKS
25	4ES-23145-00	.OIL SEAL	1	
26	4A1-23156-00	.CLIP, OIL SEAL	1	
27	4ES-23144-00	.SEAL, DUST	1	
28	4ES-23170-10	.CYLINDER COMP., FRONT FORK	1	
29	4ES-2316A-10	.VALVE COMP.	1	UR
	4LB-2316A-20	<del>VALVE COMP.</del>	1	<del>UR YZ80LW-MODEL</del>
30	2HH-23158-L0	.GASKET	1	
31	4ES-23142-00	.SEAT, SPRING UPPER	1	
32	3XJ-23357-L0	.NUT	1	
33	4ES-23141-40	.SPRING, FRONT FORK (K=0.29)	1	UR
	4LB-23141-10	<del>SPRING, FRONT FORK (K=0.30)</del>	1	<del>UR YZ80LW-MODEL</del>
34	4V4-23142-L0	.SEAT, SPRING UPPER	1	
35	4ES-23111-10	.BOLT, CAP	1	
36	3JD-2312G-L0	.PLUG	1	
37	4ES-23340-00	UNDER BRACKET COMP.	1	
38	95021-10040	BOLT, FLANGE	2	
39	4ES-2331E-00	GUIDE, CABLE	1	
40	4ES-2314F-00	PROTECTOR GUIDE COMP. 1	2	
41	4V4-23194-L0	SCREW, BOOT BAND	4	
42	4ES-2314H-L1	PROTECTOR COMP. 1	1	
43	4ES-2314J-L0	PROTECTOR COMP. 2	1	
44	4DA-23346-L0	BOLT 1	6	
45	4ES-23318-00	HOLDER, CABLE 1	1	
46	95027-06016	BOLT, FLANGE	1	

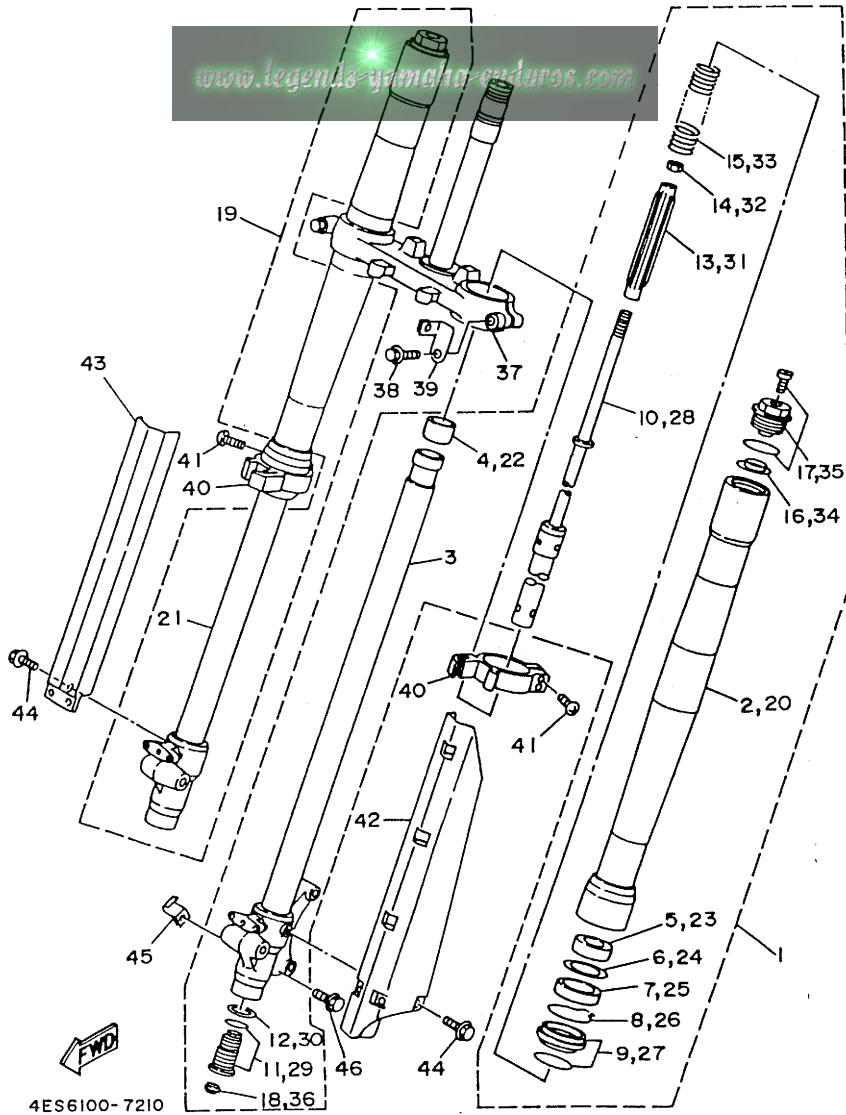

4ES6100-7210

C12

FIG. 22 FUEL TANK

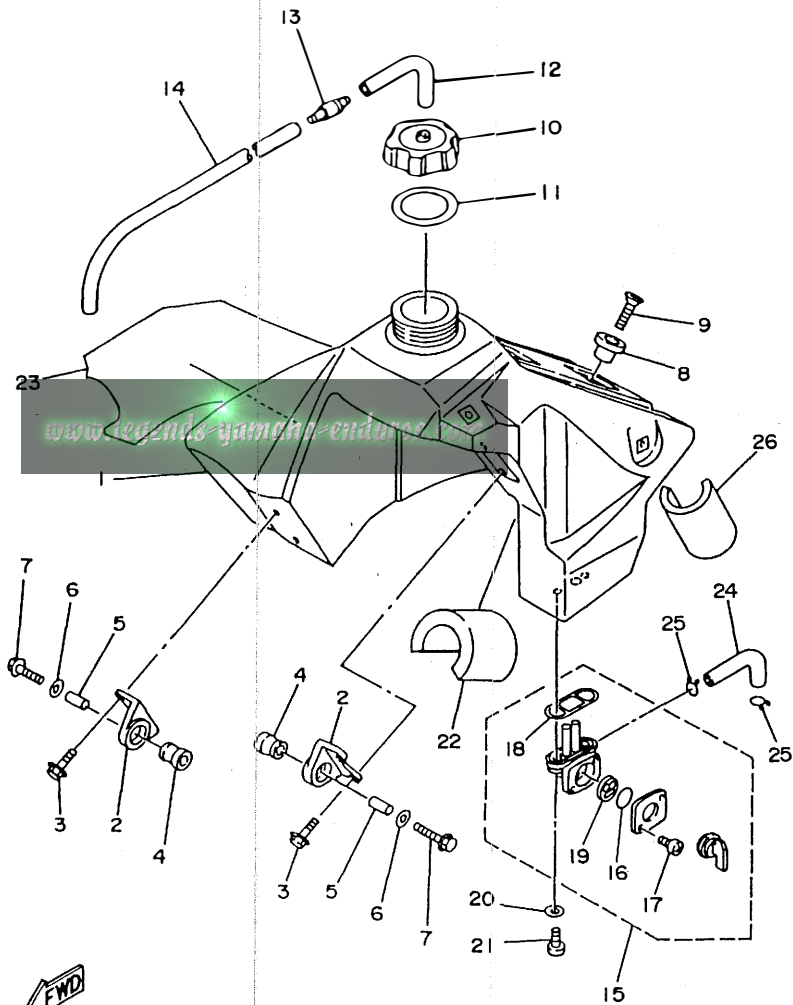

REF. NO.	PART NO.	DESCRIPTION	Q'TY	REMARKS
1	4ES-24110-11	FUEL TANK COMP.	1	
2	24X-24144-00	HOLDER, DAMPER	2	
3	95027-06016	BOLT, FLANGE	4	
4	90480-18549	GROMMET	2	
5	90387-06027	COLLAR	2	
6	90201-06697	WASHER, PLATE	2	
7	95027-06030	BOLT, FLANGE	2	
8	4EW-2412F-00	BRACKET, SEAT	1	
9	98707-06025	SCREW, FLAT HEAD	1	
10	5X7-24611-01	BODY, CAP	1	
11	5X7-24612-00	GASKET, CAP	1	
12	90445-09055	HOSE	1	
13	3XJ-24380-00	PIPE JOINT ASSY	1	
14	90445-09100	HOSE	1	
15	4DP-24500-00	FUEL COCK ASSY 1	1	
16	3AJ-24534-00	.SEAL, COCK	1	
17	98580-03008	.SCREW, PAN HEAD	2	
18	4X8-24512-00	.O-RING	1	
19	3AJ-24523-00	.VALVE PACKING	1	
20	90202-05193	WASHER, PLATE	2	
21	90149-06011	SCREW	2	
22	3Y0-24183-00	DAMPER, LOCATING 3	1	
23	4ES-24161-40	EMBLEM 1	1	
24	4ES-24311-10	PIPE, FUEL 1	1	
25	90467-10008	CLIP	2	
26	51L-28371-00	DAMPER	1	

  
4ES6100-7220

**C13**



FIG. 23 SEAT

REF. NO.	PART NO.	DESCRIPTION	QTY	REMARKS
1	4ES-24770-20	SEMI-DOUBLE SEAT ASSY	1	
2	4ES-24731-20	.COVER, SEAT	1	
3	4ES-24728-00	.BRACKET, SEAT	2	
4	95027-06012	.BOLT, FLANGE	4	
5	90119-06225	BOLT, WASHER BASED	2	

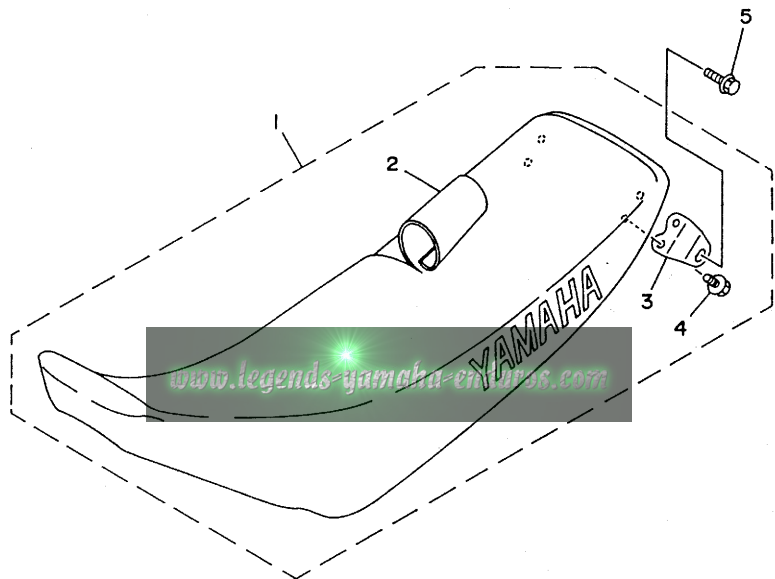

4ES6100-7230

C14

FIG. 24 FRONT WHEEL

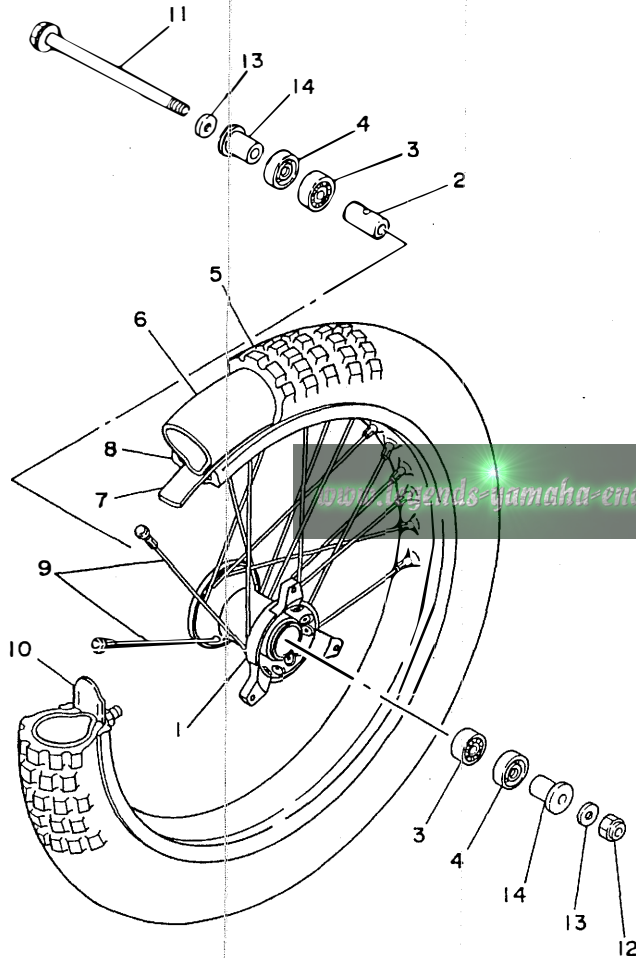

REF. NO.	PART NO.	DESCRIPTION	Q'TY	REMARKS
1	4ES-25111-00	HUB, FRONT	1	
2	90387-124H0	COLLAR	1	
3	93306-20117	BEARING	2	
4	93106-20031	OIL SEAL	2	
5	94107-177Y5	TIRE (70/100-17 40M-K490)	1	UR-DUNLOP
	<del>94107-1706B</del>	<del>TIRE (70/100-17-40M-D752F)</del>	<del>1</del>	<del>UR-DUNLOP-FOR-CANADA</del>
	<del>94107-1906D</del>	<del>TIRE (70/100-19-42M-D752F)</del>	<del>1</del>	<del>UR-DUNLOP-YZ80LW-MODEL</del>
6	94207-17284	TUBE (70/100-17 TR4)	1	UR-DUNLOP
	<del>94207-19290</del>	<del>TUBE (70/100-19-TR4)</del>	<del>1</del>	<del>UR-DUNLOP-YZ80LW-MODEL</del>
7	94307-17166	BAND, RIM (80/90,70/100-17)	1	UR-DUNLOP
	<del>94307-19170</del>	<del>BAND, RIM (70-100-19)</del>	<del>1</del>	<del>UR-DUNLOP-YZ80LW-MODEL</del>
8	94414-17530	RIM (1.40-17)	1	UR
	<del>94414-19521</del>	<del>RIM (1.40-19)</del>	<del>1</del>	<del>UR-YZ80LW-MODEL</del>
9	4ES-25104-20	SPOKE SET, FRONT	1	UR
	<del>4LB-25104-00</del>	<del>SPOKE SET, FRONT</del>	<del>1</del>	<del>UR-YZ80LW-MODEL</del>
10	1T1-25194-00	SPACER, BEAD	1	
11	4ES-25181-00	AXLE, WHEEL	1	
12	90185-12046	NUT, SELF-LOCKING	1	
13	90201-12362	WASHER, PLATE	2	
14	4ES-25183-10	COLLAR, WHEEL	2	



4ES1100-3240

C15

FIG. 25 FRONT BRAKE CALIPER

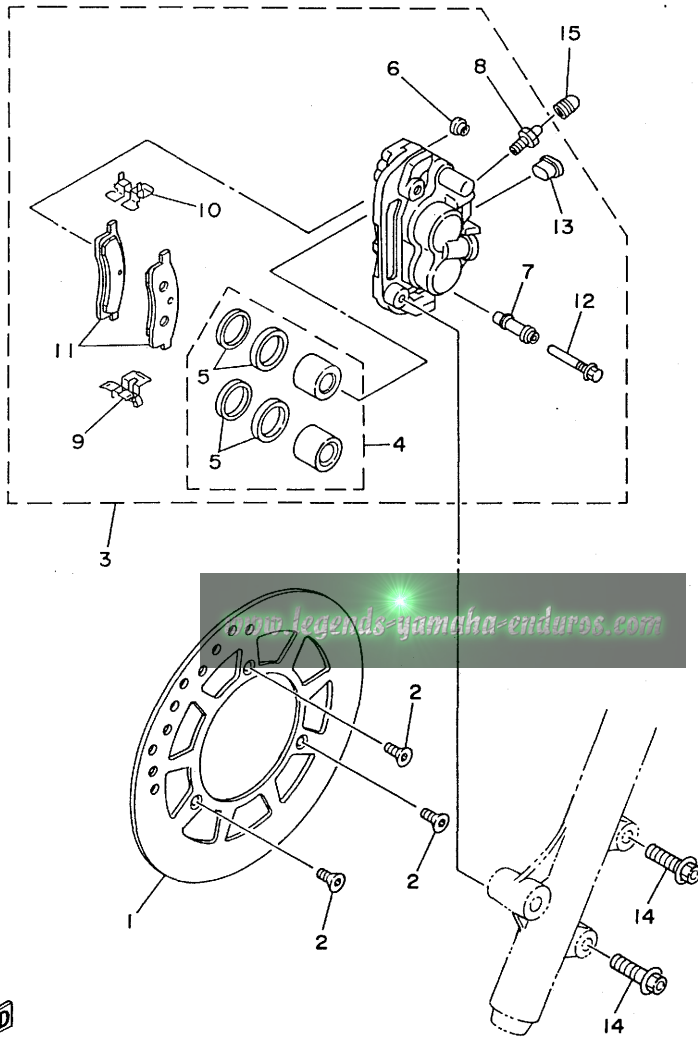

REF. NO.	PART NO.	DESCRIPTION	Q'TY	REMARKS
1	4ES-2582T-00	DISC, BRAKE	1	
2	90149-06272	SCREW	3	
3	4ES-2580T-10	CALIPER ASSY (LEFT)	1	
4	4ES-W0057-00	.PISTON ASSY, CALIPER	1	
5	4ES-W0047-00	..CALIPER SEAL KIT	1	
6	5R2-25937-00	.BOOT 2	1	
7	56A-25937-00	.BOOT 2	1	
8	47X-25824-00	.SCREW, BLEED	1	
9	56A-25919-00	.SUPPORT, PAD	1	
10	56A-25919-10	.SUPPORT, PAD	1	
11	4ES-W0045-10	.BRAKE PAD KIT	1	
12	56A-25926-00	.BOLT	1	
13	34X-25845-00	.CAP, INDICATOR	1	
14	90105-08211	BOLT, WASHER BASED	2	
15	51L-25825-00	CAP	1	



4ES3100-4250

**D2**

FIG. 26 REAR WHEEL

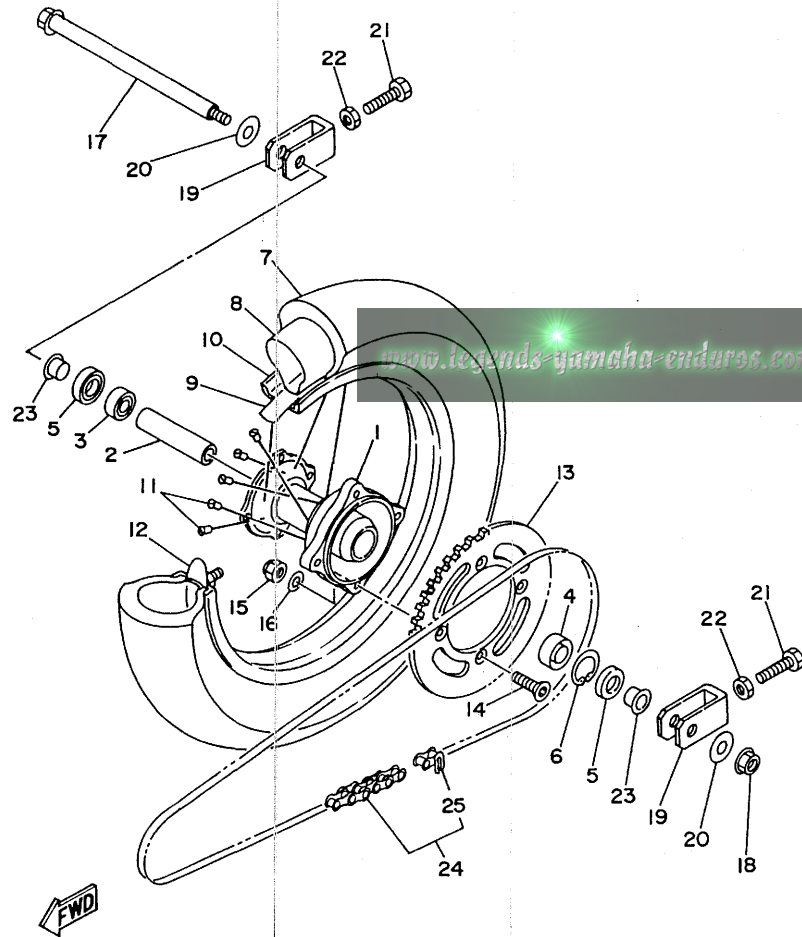

4ES1100-3260

REF. NO.	PART NO.	DESCRIPTION	Q'TY	REMARKS
1	4ES-25311-00	HUB, REAR	1	
2	4ES-25383-00	COLLAR, WHEEL	1	
3	93306-00210	BEARING	1	
4	93306-20204	BEARING (B6202Z)	1	
5	93102-20009	OIL SEAL	2	
6	99009-35500	CIRCLIP	1	
7	94109-147Y6	TIRE (90/100-14 49M K695)	1	UR-DUNLOP
	<del>94109-1406C</del>	<del>TIRE (90/100-14 49M D752)</del>	<del>1</del>	<del>UR-DUNLOP FOR CANADA</del>
	<del>94109-1606E</del>	<del>TIRE (90/100-16 52M D752)</del>	<del>1</del>	<del>UR-DUNLOP YZ80LW MODEL</del>
8	<del>94208-14285</del>	<del>TUBE (80-90/100-14 TR4)</del>	<del>1</del>	<del>UR-DUNLOP</del>
	<del>94209-16291</del>	<del>TUBE (90/100-16 TR4)</del>	<del>1</del>	<del>UR-DUNLOP YZ80LW MODEL</del>
9	94308-14165	BAND, RIM (80-90/100-14)	1	UR-DUNLOP
	<del>94307-16171</del>	<del>BAND, RIM (70-90/100-16)</del>	<del>1</del>	<del>UR-DUNLOP YZ80LW MODEL</del>
10	94416-14529	RIM (1.60-14)	1	UR
	<del>94418-16522</del>	<del>RIM (1.85-16)</del>	<del>1</del>	<del>UR YZ80LW MODEL</del>
11	4ES-25304-20	SPOKE SET, REAR	1	UR
	<del>4LB-25304-00</del>	<del>SPOKE SET, REAR</del>	<del>1</del>	<del>UR YZ80LW MODEL</del>
12	5X2-25394-00	SPACER, BEAD	1	UR
	<del>1T2-25394-00</del>	<del>SPACER, BEAD</del>	<del>1</del>	<del>UR YZ80LW MODEL</del>
13	4ES-25447-20	SPROCKET, DRIVEN (47T)	1	STD
	<del>4ES-25446-00</del>	<del>SPROCKET, DRIVEN (46T)</del>	<del>1</del>	<del>AP</del>
	<del>4ES-25448-00</del>	<del>SPROCKET, DRIVEN (48T)</del>	<del>1</del>	<del>AP</del>
14	90109-081G2	BOLT	4	
15	95617-08100	NUT, U	4	
16	90201-086P8	WASHER, PLATE	4	
17	4ES-25381-01	AXLE, WHEEL	1	
18	95607-14200	NUT, SELF-LOCKING	1	
19	4ES-25388-00	PULLER, CHAIN 1	2	

**D3**

FIG. 26 REAR WHEEL

REF. NO.	PART NO.	DESCRIPTION	QTY	REMARKS
20	90201-161R1	WASHER, PLATE	2	
21	90101-08475	BOLT	2	
22	95307-08700	NUT	2	
23	4ES-25383-10	COLLAR, WHEEL	2	
24	<del>9Y581-58117</del>	CHAIN (DID428G2 118L)	1	UR
	<del>9Y581-58119</del>	<del>CHAIN (DID428-118L)</del>	1	<del>UR-YZ80LW-MODEL</del>
25	<del>94681-58001</del>	<del>JOINT, CHAIN (DID 428G2)</del>	1	

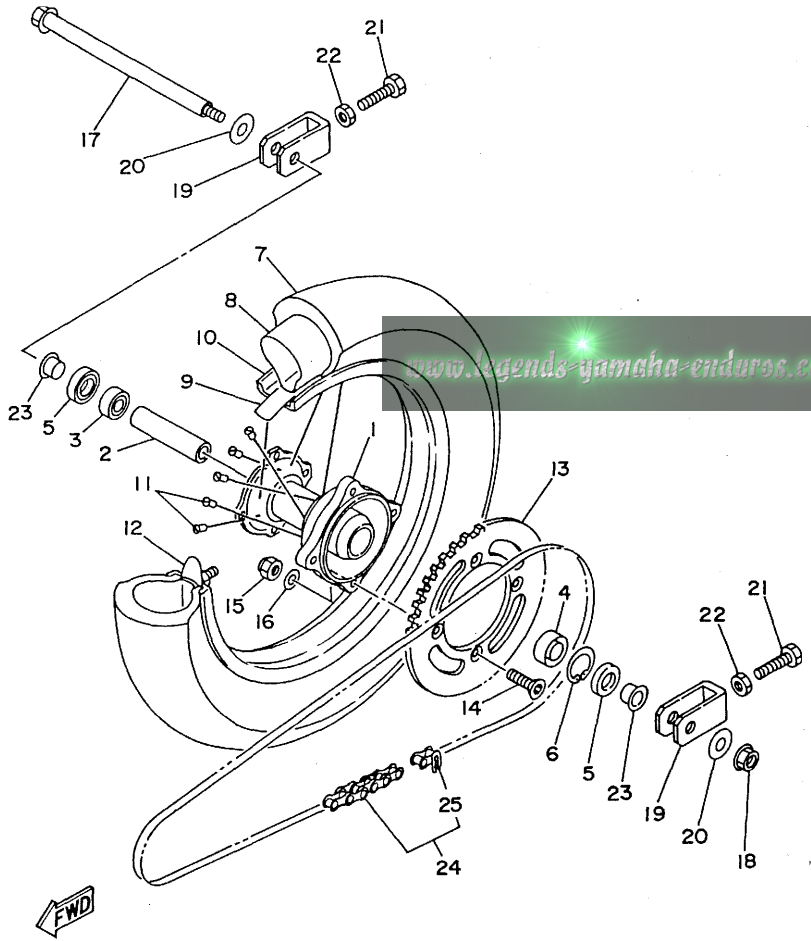

4ES1100-3260

D4

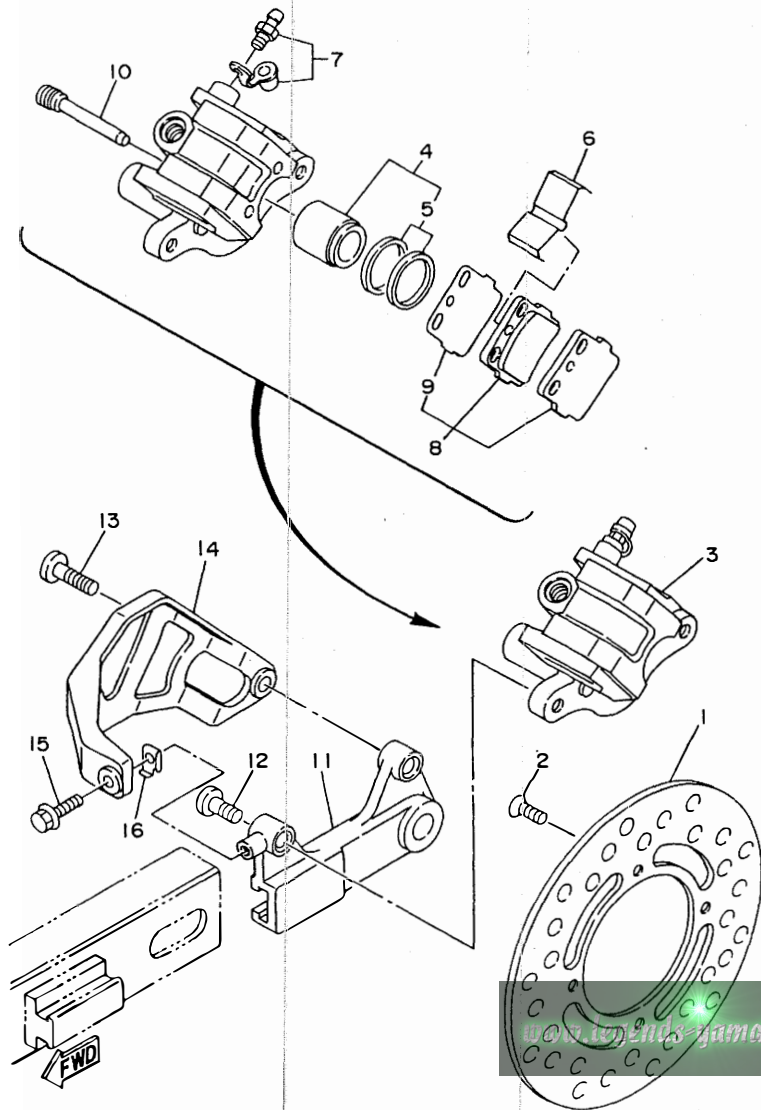
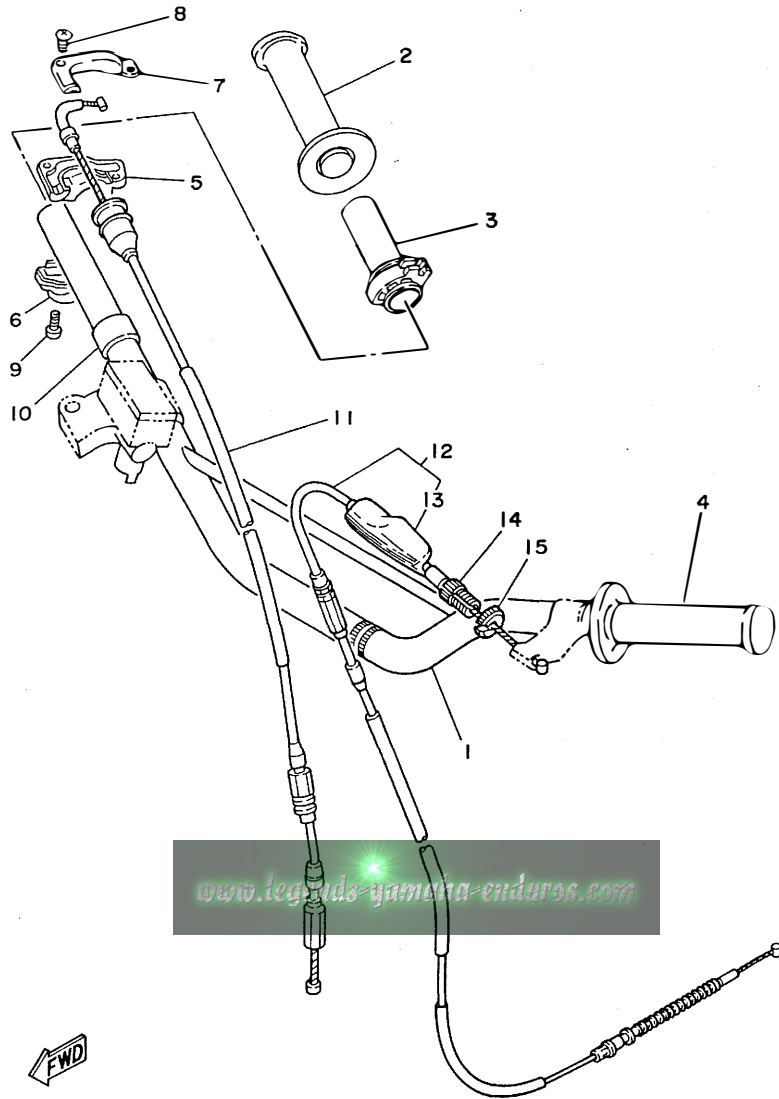

FIG. 27 REAR BRAKE CALIPER

REF. NO.	PART NO.	DESCRIPTION	Q'TY	REMARKS
1	4ES-2582W-00	DISC, REAR BRAKE 2	1	
2	90149-06272	SCREW	4	
3	4ES-2580W-00	CALIPER ASSY, REAR 2	1	
4	4ES-W0057-00	.PISTON ASSY, CALIPER	1	
5	4ES-W0047-00	..CALIPER SEAL KIT	1	
6	1UY-25919-51	.SUPPORT, PAD	1	
7	36Y-W0048-00	.BLEED SCREW KIT	1	
8	4ES-W0046-50	.BRAKE PAD KIT 2	1	
9	3GD-25827-00	..SHIM, CALIPER	1	
10	3GD-25933-00	.PIN, PAD	2	
11	4ES-25920-00	SUPT. BRKT. ASSY	1	
12	90110-08096	BOLT, HEXAGON SOCKET HEAD	1	
13	90109-08718	BOLT	1	
14	4ES-27491-00	PROTECTOR	1	
15	95027-06012	BOLT	1	
16	4ES-27114-00	STOPPER, MAIN STAND	1	

4ES1100-3270



[www.legends-yamaha-enduros.com](http://www.legends-yamaha-enduros.com)

FIG. 28 STEERING HANDLE. CABLE

REF. NO.	PART NO.	DESCRIPTION	QTY	REMARKS
1	4ES-26111-30	HANDLEBAR	1	
2	4GY-26242-00	GRIP (RIGHT)	1	
3	22W-26243-00	TUBE, THROTTLE GUIDE	1	
4	4GY-26241-00	GRIP (LEFT)	1	
5	5X2-26281-00	CAP, GRIP UPPER	1	
6	322-26282-00	CAP, GRIP LOWER	1	
7	5X2-2628H-01	CAP, WIRE	1	
8	98707-04012	SCREW, FLAT HEAD	2	
9	98507-05016	SCREW, PAN HEAD	2	
10	90387-220G4	COLLAR	1	
11	4ES-26311-00	CABLE, THROTTLE 1	1	
12	4ES-26335-11	CABLE, CLUTCH	1	
13	498-26372-00	.COVER, HANDLE LEVER 1	1	
14	90123-08013	BOLT	1	
15	90179-08148	NUT	1	



4ES6100-7280

D6

FIG. 29 FRONT MASTER CYLINDER

REF. NO.	PART NO.	DESCRIPTION	Q'TY	REMARKS
1	4ES-25872-02	HOSE, BRAKE 1	1	
2	90201-10118	WASHER, PLATE	4	
3	90401-10159	BOLT, UNION	2	
4	4SS-W2587-00	MASTER CYLINDER SUB ASSY	1	
5	4SS-W0041-00	.CYLINDER KIT, MASTER	1	
6	98707-04012	.SCREW, FLAT HEAD	2	
7	4SS-25852-00	.CAP, RESERVOIR	1	
8	4SS-25854-00	.DIAPHRAGM, RESERVOIR	1	
9	4SS-25889-00	.SEPARATOR ASSY	1	
10	4SS-25880-00	.PUSH ROD COMP.	1	
11	4SS-25868-00	.BOOT, MASTER CYLINDER	1	
12	4SS-2538E-00	NUT, ADJUSTING	2	
13	4SS-83913-00	COLLAR, LEVER 1	1	
14	3YX-25866-10	CIRCLIP	1	
15	4SS-25866-00	CIRCLIP	1	
16	4SS-2583G-00	WASHER	1	
17	4SS-83922-00	LEVER 2	1	
18	95617-06100	NUT, U	1	
19	4SS-2589F-00	BOLT, LEVER	1	
20	3YK-25867-00	BRACKET, MASTER CYLINDER	1	
21	4SS-25833-00	BOLT, FITTING	2	
22	4SS-26372-00	COVER, HANDLE LEVER 1	1	

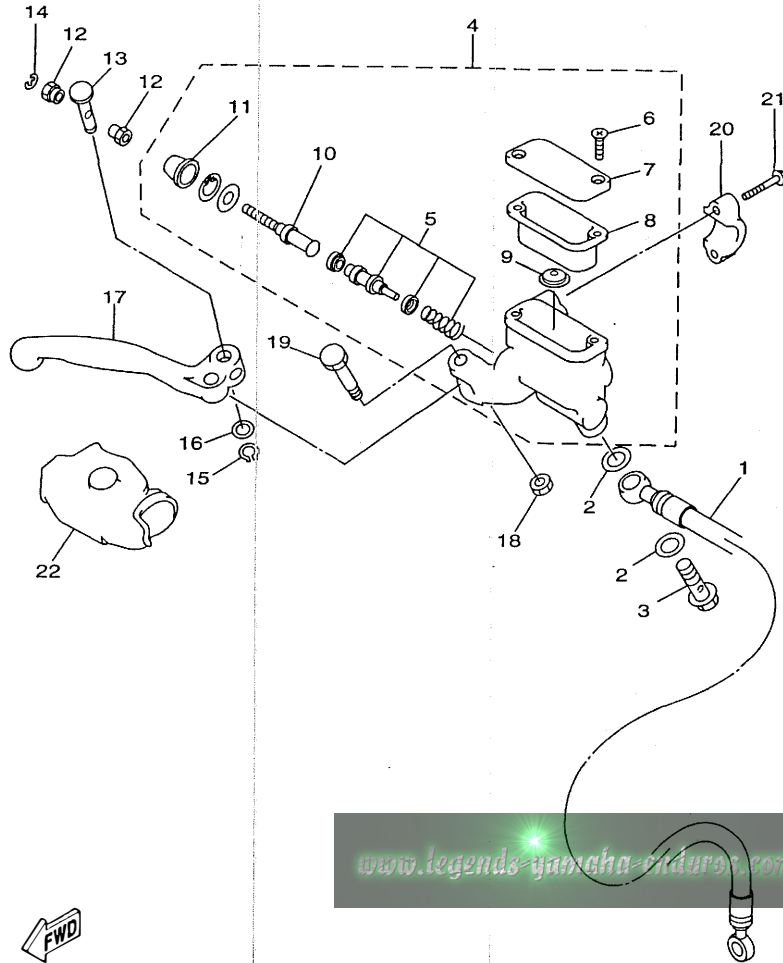

[www.legends-yamaha-riders.com](http://www.legends-yamaha-riders.com)



4ES6100-7290

**D7**



FIG. 30 STAND, FOOTREST

REF. NO.	PART NO.	DESCRIPTION	Q'TY	REMARKS
1	4ES-27211-00	PEDAL, BRAKE	1	
2	90506-15480	SPRING, TENSION	1	
3	91401-20030	PIN, COTTER	1	
4	90201-154E8	WASHER, PLATE	1	
5	4ES-27311-00	STAND, SIDE	1 UR	
	<del>4LB-27311-00</del>	<del>STAND, SIDE</del>	<del>1</del>	<del>UR-YZ80LW-MODEL</del>
6	3LD-27411-00	FOOTREST 1	1	
7	90508-28777	SPRING, TORSION	1	
8	90240-10117	PIN, CLEVIS	1	
9	91401-25020	PIN, COTTER	1	
10	90201-10119	WASHER, PLATE	1	
11	4DA-27421-00	FOOTREST 2	1	
12	90240-10117	PIN, CLEVIS	1	
13	91401-25020	PIN, COTTER	1	
14	90508-28777	SPRING, TORSION	1	
15	90201-10119	WASHER, PLATE	1	

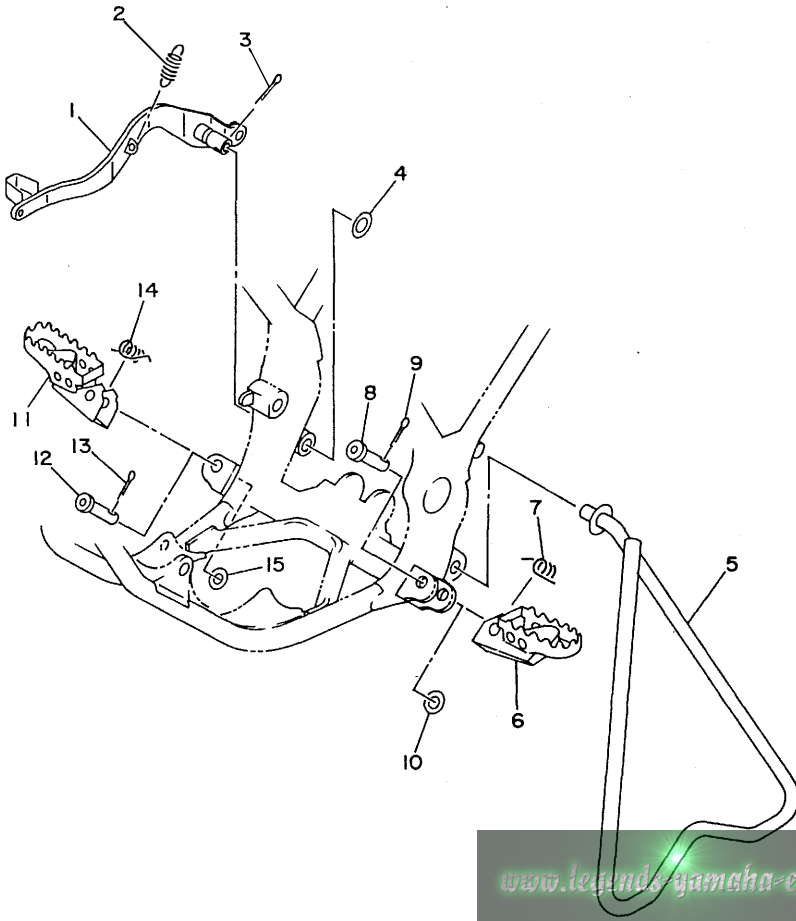

  
4ES1100-3300

**D8**

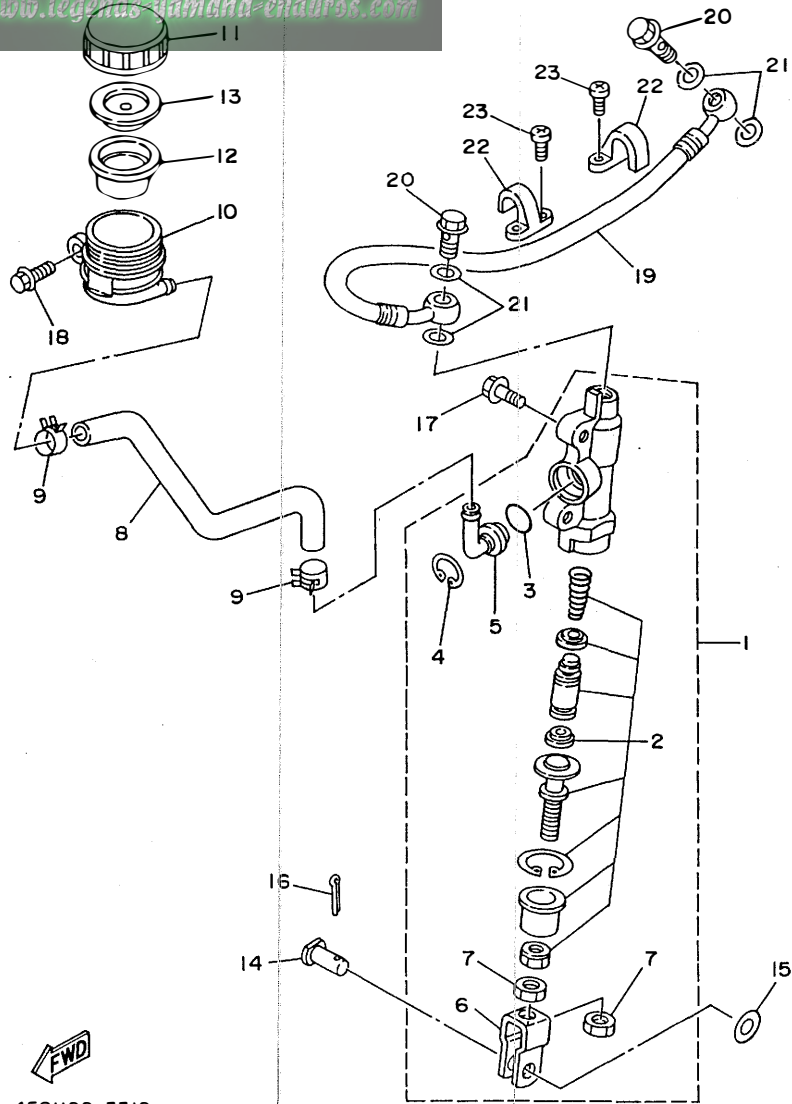

FIG. 31 REAR MASTER CYLINDER

REF. NO.	PART NO.	DESCRIPTION	Q'TY	REMARKS
1	4ES-2583V-00	RR. MASTER CYLINDER ASSY	1	
2	1FK-W0042-50	.CYLINDER KIT, MASTER	1	
3	93210-15620	.O-RING	1	
4	2VN-25866-00	.CIRCLIP	1	
5	2VN-2582A-50	.JOINT	1	
6	2YK-27222-00	.JOINT	1	
7	95307-08600	.NUT	2	
8	4ES-25895-00	HOSE, RESERVOIR	1	
9	90467-11044	CLIP	2	
10	4EW-25894-00	TANK, RESERVOIR	1	
11	3XP-25852-50	CAP, RESERVOIR	1	
12	2VN-25854-00	DIAPHRAGM, RESERVOIR	1	
13	2VN-25855-00	BUSH,DIAPHRAGM	1	
14	90240-08124	PIN, CLEVIS	1	
15	90201-08083	WASHER, PLATE	1	
16	91401-16020	PIN, COTTER	1	
17	95027-06016	BOLT	2	
18	95027-06012	BOLT	1	
19	4ES-25873-01	HOSE, BRAKE 2	1	UR
	<del>4LB-25873-01</del>	<del>HOSE, BRAKE 2</del>	<del>1</del>	<del>UR-YZ80LW-MODEL</del>
20	90401-10159	BOLT, UNION	2	
21	90201-10118	WASHER, PLATE	4	
22	2VM-25876-00	HOLDER, BRAKE HOSE 2	2	
23	97780-50110	SCREW, TAPPING	4	



4ES1100-3310

**D9**

FIG. 32 GENERATOR

REF. NO.	PART NO.	DESCRIPTION	QTY	REMARKS
1	4ES-85510-20	STATOR ASSY	1	
2	4ES-85550-10	ROTOR ASSY	1	
3	98507-06016	SCREW, PAN HEAD	2	
4	92907-06600	WASHER, PLATE	2	
5	95317-10600	NUT	1	
6	90201-10774	WASHER, PLATE	1	
7	437-83936-01	BAND, SWITCH CORD	3	

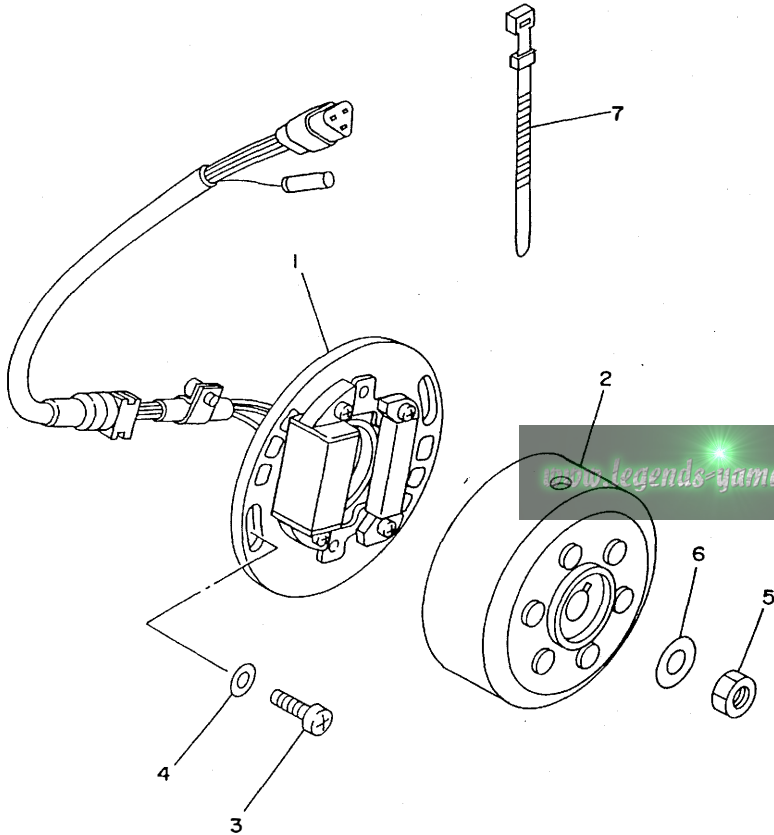

[www.legends-yamaha-enduros.com](http://www.legends-yamaha-enduros.com)



4GT3300-4320

D10

www.legendsofmahaeenduros.com

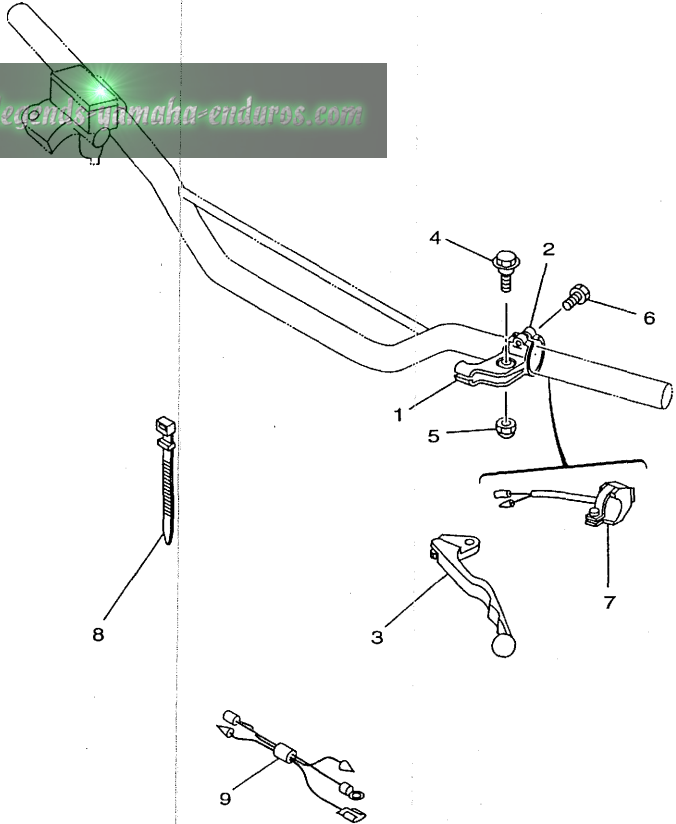

FIG. 33 HANDLE SWITCH. LEVER

REF. NO.	PART NO.	DESCRIPTION	Q'TY	REMARKS
1	38V-82911-00	HOLDER, LEVER 1	1	
2	38V-82913-00	HOLDER, LEVER LOWER 1	1	
3	4GY-83912-00	LEVER 1	1	
4	90109-06799	BOLT	1	
5	95607-06100	NUT, U	1	
6	97007-05016	BOLT	2	
7	23X-83976-00	SWITCH, HANDLE 1	1	
8	437-83936-01	BAND, SWITCH CORD	2	
9	4ES-82509-00	WIRE, SUB LEAD	1	

  
4ES6100-7330

**D11**

FIG. 34 ELECTRICAL 1

REF. NO.	PART NO.	DESCRIPTION	QTY	REMARKS
1	4ES-85540-20	C.D.I. UNIT ASSY	1	
2	2A7-85546-00	BAND	1	
3	437-83936-11	BAND, SWITCH CORD	1	
4	4KJ-82310-00	IGNITION COIL ASSY	1	
5	95027-06016	BOLT, FLANGE	2	
6	81E-82370-20	PLUG CAP ASSY	1	

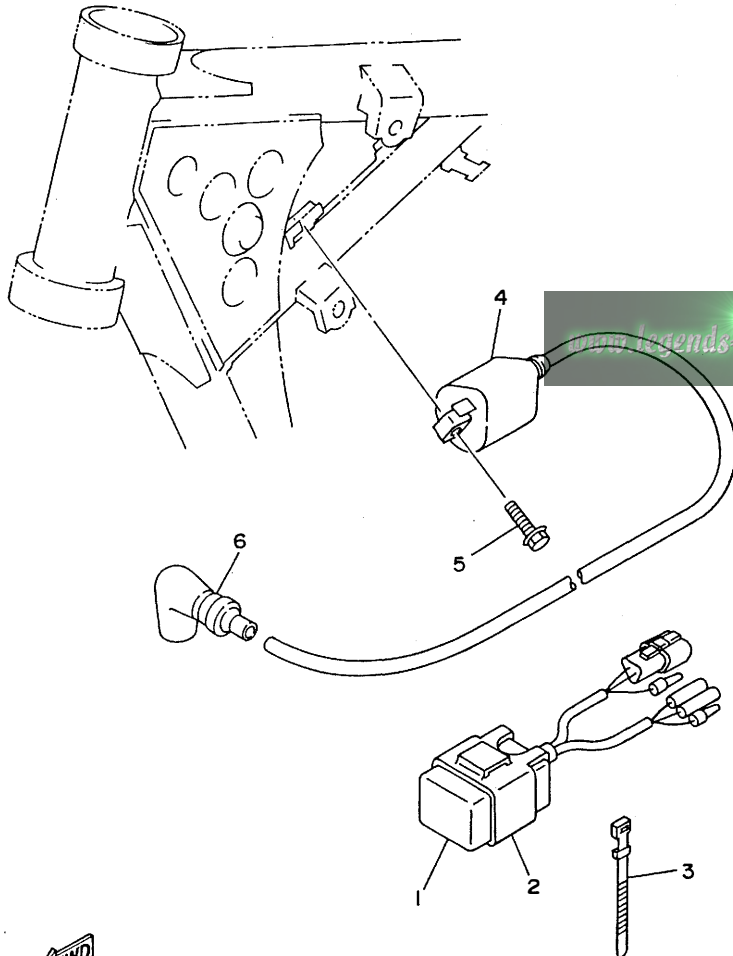

4ES6100-7340

D12

FIG. 35 ALTERNATE (CHASSIS)

REF. NO.	PART NO.	DESCRIPTION	Q'TY	REMARKS
1	4ES-22212-C0	SPRING (K=4.8)	1	AP (SOFT)
	4ES-22212-B0	SPRING (K=5.0)	1	AP (SOFT) <sup>STD</sup> YZ80LW-MODEL
	4ES-22212-D0	SPRING (K=5.2)	1	AP (HARD)
	4ES-22212-E0	SPRING (K=5.4)	1	AP (HARD) YZ80LW-MODEL
2	4ES-23141-50	SPRING, FRONT FORK (K=0.28)	2	AP (SOFT)
	4ES-23141-40	SPRING, FRONT FORK (K=0.29)	2	AP (SOFT) <sup>STD</sup> YZ80LW-MODEL
	4ES-23141-60	SPRING, FRONT FORK (K=0.30)	2	AP (HARD)
	4ES-23141-70	SPRING, FRONT FORK (K=0.31)	2	AP (HARD) YZ80LW-MODEL

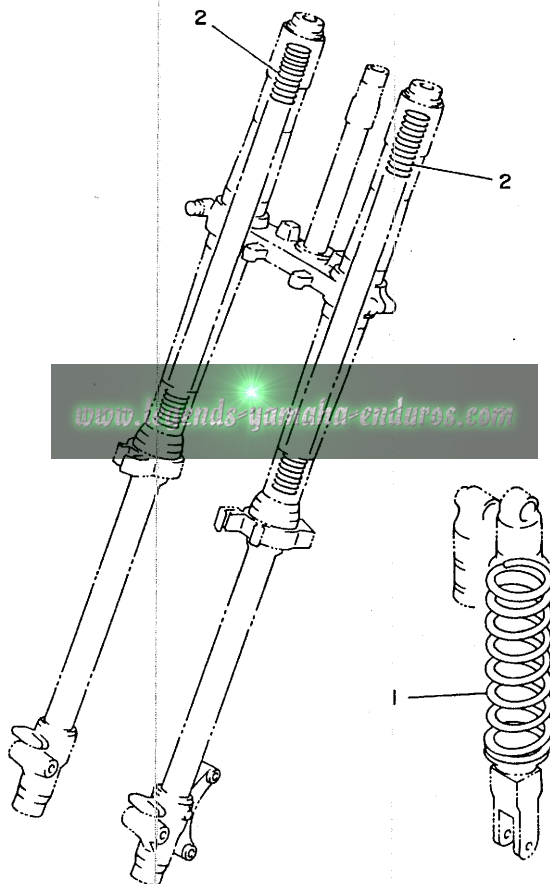

4ES1100-3350

**D13**

FIG. 36 REPAIR KIT

REF. NO.	PART NO.	DESCRIPTION	Q'TY	REMARKS
1	4ES-11630-01	PISTON ASSY (STD)	1	
2	4ES-11631-01-B0	.PISTON (STD)	1	
3	43K-11611-00	.RING, PISTON	1	
4	4ES-11633-00	.PIN, PISTON	1	
5	93450-16115	.CIRCLIP	2	
6	4ES-11650-01	CONNECTING ROD ASSY	1	
7	4ES-11651-01	.ROD, CONNECTING	1	
8	93310-320T3	.BEARING, CYLINDRICAL	1	
9	2RA-11681-00	.PIN, CRANK 1	1	
10	90209-20159	.WASHER	2	
11	93310-214F8	.BEARING, CYLINDRICAL	1	KOYO

[www.legends-yamaha-enduros.com](http://www.legends-yamaha-enduros.com)

[www.legends-yamaha-enduros.com](http://www.legends-yamaha-enduros.com)



NUMERICAL INDEX

PART NO.	GRID NO.	PART NO.	GRID NO.	PART NO.	GRID NO.	PART NO.	GRID NO.	PART NO.	GRID NO.	PART NO.	GRID NO.
4SS-W0041-00	D- 7	23L-14107-25	B- 7	4ES-15620-00	B-12	4ES-21732-00	C- 6	4ES-2314F-00	C-12	24X-24144-00	C-13
1FK-W0042-50	D- 9	2X6-14112-25	B- 7	4ES-15621-00	B-12	4ES-21735-00	C- 6	4ES-2314H-L1	C-12	4ES-24161-40	C-13
4ES-W0045-10	D- 2	2X6-14112-30	B- 7	4ES-15641-00	B-12	4DJ-2174A-00	C- 6	4ES-2314J-L0	C-12	22W-24181-00	C- 6
4ES-W0046-50	D- 5	2X6-14112-35	B- 7	4ES-15651-00	B-12	4ES-21781-00	C- 6	4ES-23141-40	C-11	3Y0-24183-00	C-13
4ES-W0047-00	D- 2	3R1-14115-00	B- 7	4ES-15660-00	B-12	4ES-21790-00	C- 6		C-12	4ES-24311-10	C-13
	D- 5	2A6-14126-00	B- 8	4ES-15664-00	B-12	4ES-22110-00	C- 7		D-13	3XJ-24380-00	C-13
36Y-W0048-00	D- 5	248-14131-00	B- 7	4ES-16111-00	B-13	4LB-22110-00	C- 7	4ES-23141-50	D-13	4DP-24500-00	C-13
4ES-W0057-00	D- 2	3R1-14141-50	B- 7	4ES-16150-11	B-13	4ES-22129-00	C- 7	4ES-23141-60	D-13	4X8-24512-00	C-13
	D- 5	3R1-14141-52	B- 7	4V0-16154-00	B-13	4ES-22151-00	C- 7	4ES-23141-70	D-13	3AJ-24523-00	C-13
4SS-W2587-00	D- 7	3R1-14141-54	B- 7	21V-16321-00	B-13	4ES-2217A-00	C- 7	4LB-23141-10	C-11	3AJ-24534-00	C-13
4LC-11111-00	B- 2	260-14142-30	B- 7	4ES-16321-00	B-13	4ES-2217F-00	C- 8		C-12	5X7-24611-01	C-13
4ES-11311-10	B- 2	260-14142-32	B- 7	131-16324-00	B-13	30X-22178-00	C- 4	4ES-23142-00	C-11	5X7-24612-00	C-13
4ES-11351-00	B- 2	260-14142-35	B- 7	257-16324-00	B-13	4ES-22178-00	C- 4		C-12	4ES-24728-00	C-14
4ES-11400-02	B- 3	137-14143-58-A1	B- 7	2TK-16351-00	B-13	4V4-22184-00	C- 4	4V4-23142-L0	C-11	4ES-24731-20	C-14
4ES-11412-00	B- 3	137-14143-60-A0	B- 7	4ES-16356-00	B-13	39K-22199-00	C- 7		C-12	4ES-24770-20	C-14
4ES-11422-00	B- 3	137-14143-62-A0	B- 7	2RA-16357-00	B-13	4ES-22201-30	C- 9	4ES-23144-00	C-11	4ES-25104-20	C-15
43K-11611-00	B- 3	39K-14153-00	B- 7	37F-16371-01	B-13	4ES-22201-40	C- 9		C-12	4LB-25104-00	C-15
	D-14	2A6-14158-00	B- 8	4ES-16381-00	B-13	4ES-22201-50	C- 9	4ES-23145-00	C-11	4ES-25111-00	C-15
4ES-11630-01	D-14	3X3-14169-00	B- 7	4ES-17121-01	B-14	4LB-22201-40	C- 9		C-12	22W-25181-01	C- 7
4ES-11631-01-A0	B- 3	3SB-14171-00	B- 8	4ES-17131-00	B-14	4ES-22210-A0	C- 9	5K5-23149-00	C-11	4ES-25181-00	C-15
4ES-11631-01-B0	B- 3	304-14184-00	B- 7	4ES-17151-00	B-14	4ES-22210-B0	C- 9		C-11	4ES-25183-10	C-15
	D-14	314-14185-00	B- 7	4ES-17161-00	B-14	4ES-22210-90	C- 9	4A1-23156-00	C-11	1T1-25194-00	C-15
4ES-11631-01-C0	B- 3	127-14186-00	B- 7	4ES-17211-01	B-14	4LB-22210-40	C- 9		C-12	4ES-25304-20	D- 3
4ES-11631-01-D0	B- 3	3JN-14196-00	B- 8	4ES-17221-01	B-14	4ES-22212-B0	C- 9	2HH-23158-L0	C-11	4LB-25304-00	D- 3
4ES-11633-00	B- 3	278-14197-00	B- 7	4ES-17231-01	B-14		D-13		C-12	4ES-25311-00	D- 3
	D-14	3Y1-14197-00	B- 8	4ES-17241-00	B-14	4ES-22212-C0	D-13	4ES-2316A-10	C-11	4SS-2538E-00	D- 7
4ES-11650-01	D-14	4ES-14411-01	B- 6	4ES-17251-00	B-14	4ES-22212-D0	C- 9		C-12	4ES-25381-01	D- 3
4ES-11651-01	B- 3	4ES-14417-00	B- 6	4ES-17261-01	B-14		D-13	4LB-2316A-20	C-11	4ES-25383-00	D- 3
	D-14	4ES-14451-00	B- 6	4ES-17411-01	B-14	4ES-22212-E0	D-13		C-12	4ES-25383-10	D- 4
2RA-11681-00	B- 3	4ES-14453-00	B- 6	4ES-17421-00	B-14	3JD-22214-00	C- 9	4ES-23170-10	C-11	4ES-25388-00	D- 3
	D-14	4ES-14458-00	B- 6	164-17427-00-06	B-14	4ES-22214-00	C- 9		C-12	1T2-25394-00	D- 3
4BA-12422-00	B- 4	4ES-14459-00	B- 6	4ES-18101-00	C- 3	4ES-22216-00	C- 9	4ES-23171-00	C-11	5X2-25394-00	D- 3
4BA-12428-00	B- 4	4ES-14462-00	B- 6	2HF-18110-01	C- 3	4ES-22251-00	C- 9		C-11	4ES-25446-00	D- 3
36F-12450-00	B- 4	4ES-14610-10	B- 9	4BA-18140-00	C- 3	3XJ-22475-00	C- 8	58T-23184-L0	C- 9	4ES-25447-20	D- 3
4ES-12459-00	B- 4	17W-14615-00	B- 9	4ES-18511-01	C- 2	4ES-23102-20	C-11	4V4-23194-L0	C-12	4ES-25448-00	D- 3
4ES-12461-00	B- 5	4ES-1469A-00	B- 9	4V0-18512-00	C- 2	4LB-23102-20	C-11	4ES-2331E-00	C-12	4ES-2580T-10	D- 2
22W-12462-00	B- 5	4ES-14753-00	B- 9	4ES-18513-01	C- 2	4ES-23103-20	C-11	4ES-23318-00	C-12	4ES-2580W-00	D- 5
22W-12463-00	B- 5	565-14771-00	B- 9	4BA-18531-00	C- 2	4LB-23103-20	C-11	4ES-23340-00	C-12	2VN-2582A-50	D- 9
4ES-12481-00	B- 5	58T-1490J-00	B- 7	4BA-18535-00	C- 2	4ES-23110-00	C-11	4DA-23346-L0	C-12	4ES-2582T-00	D- 2
4ES-12482-00	B- 5	25G-14937-00	B- 8	4ES-18540-00	C- 2	4ES-23111-10	C-11	3XJ-23357-L0	C-11	4ES-2582W-00	D- 5
4ES-13565-00	B- 6	4ES-15111-00	B-10	4ES-21110-01-2F	C- 4		C-12		C-12	47X-25824-00	D- 2
4ES-13610-00	B- 6	4ES-15121-01	B-10	4ES-21511-10	C- 5	3JD-2312G-L0	C-11	4DA-23389-00	C-10	51L-25825-00	D- 2
4ES-13613-00	B- 6	1RG-15363-00	B-11	4ES-21611-00	C- 5		C-12	1J7-23415-00	C-10	3GD-25827-00	D- 5
4ES-13616-00	B- 6	583-15371-00	B-10	4ES-21642-00	C- 5	4ES-23120-00	C-11	4ES-23435-00	C-10	4SS-25836-00	D- 7
4ES-14101-10	B- 7	4ES-15411-00	B-11	4ES-21711-00	C- 6	4ES-23125-00	C-11	3SP-23441-00	C-10	4ES-2583V-00	D- 9
31J-14103-00	B- 7	4ES-15421-01	B-11	4EW-2172A-10	C- 6		C-11	4ES-23485-10	C-10	4SS-25833-00	D- 7
10W-14104-00	B- 8	4ES-15451-00	B-11	4ES-21721-00	C- 6	4ES-23136-20	C-11	4ES-24110-11	C-13	34X-25845-00	D- 2
22W-14106-00	B- 7	4ES-15461-00	B-11	4ES-21731-10	C- 6		C-11	4EW-2412F-00	C-13	3XP-25852-50	D- 9

NUMERICAL INDEX

PART NO.	GRID NO.	PART NO.	GRID NO.	PART NO.	GRID NO.	PART NO.	GRID NO.	PART NO.	GRID NO.	PART NO.	GRID NO.
4SS-25852-00	D- 7	81E-82370-20	D-12	90176-08026	B- 2	90240-10117	D- 8	90506-15480	D- 8	93317-11245	B-14
2VN-25854-00	D- 9	4E5-82509-00	D-11	90179-08148	D- 6		D- 8	90507-20030	B- 9	93317-21746	C- 7
4SS-25854-00	D- 7	38V-82911-00	D-11	90179-08491	B- 2	90250-06013	C- 2	90508-242A6	C- 3	93317-31771	C- 7
2VN-25855-00	D- 9	38V-82913-00	D-11	90179-12659	B-13	90267-40077	B- 6	90508-26750	B-12		C- 8
2VN-25866-00	D- 9	4GY-83912-00	D-11		B-13	90280-03017	B- 3	90508-28777	D- 8	93332-00079	C-10
3YX-25866-10	D- 7	4SS-83913-00	D- 7	90179-22412	C-10	90282-05001	B-13		D- 8	93399-99921	C- 8
4SS-25866-00	D- 7	4SS-83922-00	D- 7	90179-25033	C-10	90338-10150	C- 8	90508-32553	C- 3	93410-20038	B-14
3YK-25867-00	D- 7	437-83936-01	B- 5	90183-06023	C- 6	90380-10218	C- 7	91401-16020	D- 9	93430-08007	B-12
4SS-25868-00	D- 7		D-10	90183-06069	C- 6	90380-12219	C- 7	91401-20030	D- 8	93440-15012	B-14
4E5-25872-02	D- 7		D-11	90185-10120	C- 9	90381-12091	C- 8	91401-25020	D- 8	93440-17064	B-14
4E5-25873-01	D- 9	437-83936-11	D-12	90185-12046	C-15	90385-17042	C- 7		D- 8	93440-30113	C- 8
4LB-25873-01	D- 9	23X-83976-00	D-11	90185-12119	C- 8	90387-06027	C-13	92907-03100	B- 6	93450-16115	B- 3
2VM-25876-00	D- 9	4E5-85510-20	D-10	90201-047A2	B- 6	90387-062M9	C- 6	92907-04100	B- 7		D-14
4SS-25880-00	D- 7	4E5-85540-20	D-12	90201-060A3	B- 9	90387-062X0	C- 7	92907-04600	B- 6	93503-16010	B-13
4SS-25889-00	D- 7	2A7-85546-00	D-12	90201-063J2	B- 5	90387-062I6	C- 4	92907-06600	D-10	93507-32031	B-12
4SS-2589F-00	D- 7	4E5-85550-10	D-10	90201-065F3	B-12	90387-063G3	B- 9	92907-10600	C- 9	93603-22028	B- 4
4EW-25894-00	D- 9	9Y581-58117	D- 4		B-14	90387-064X4	C- 5	93101-12060	C- 3	93822-12012	B-14
4E5-25895-00	D- 9	9Y581-58119	D- 4	90201-06697	C-13	90387-0700G	B- 5	93101-17062	C- 7	93822-13024	B-14
1UY-25919-51	D- 5	90101-08475	D- 4	90201-08083	D- 9	90387-103X9	C- 8		C- 8	93822-14037	B-14
56A-25919-00	D- 2	90101-12755	C- 8	90201-08087	B- 2	90387-105L0	B- 9	93102-12224	B-13	93822-15065	B-14
56A-25919-10	D- 2	90105-08211	D- 2		B-11	90387-1200U	C- 7	93102-17263	B-12	94107-1706B	C-15
4E5-25920-00	D- 5	90105-08310	C- 7	90201-081R9	C- 4	90387-124H0	C-15	93102-20009	D- 3	94107-177Y5	C-15
56A-25926-00	D- 2	90105-10582	C- 7	90201-08512	B- 4	90387-126Y7	C- 3	93102-20143	B-14	94107-1906D	C-15
3GD-25933-00	D- 5	90105-10614	C- 9	90201-086P8	D- 3	90387-127J7	C- 7	93102-20447	B- 3	94109-1406C	D- 3
5R2-25937-00	D- 2	90105-12382	C- 7	90201-10118	D- 7	90387-127J8	C- 7	93103-10168	B- 4	94109-147Y6	D- 3
56A-25937-00	D- 2	90109-067F4	C- 6		D- 9	90387-20488	B-13	93103-28126	B- 3	94109-1606E	D- 3
4E5-26111-30	D- 6	90109-06799	D-11	90201-10119	D- 8	90387-220G4	D- 6	93106-20031	C-15	94207-17284	C-15
4GY-26241-00	D- 6	90109-081G2	D- 3		D- 8	90401-10159	D- 7	93109-17048	C- 7	94207-19290	C-15
4GY-26242-00	D- 6	90109-08718	D- 5	90201-10774	D-10		D- 9	93210-15620	D- 9	94208-14285	D- 3
22W-26243-00	D- 6	90109-10729	C- 9	90201-12362	C-15	90430-06166	B- 4	93210-18288	B- 7	94209-16291	D- 3
5X2-2628H-01	D- 6	90110-08096	D- 5	90201-124F8	B-12	90445-09055	C-13	93210-19123	B-11	94307-16171	D- 3
5X2-26281-00	D- 6	90116-08318	B- 2	90201-124G9	C- 7	90445-09100	C-13	93210-371A9	B- 9	94307-17166	C-15
322-26282-00	D- 6	90116-08388	B- 2	90201-12631	B-12	90446-07349	B-10	93210-56459	B- 2	94307-19170	C-15
4E5-26311-00	D- 6	90116-08394	B- 2	90201-12749	C- 8	90450-28014	B- 5	93210-84724	B- 2	94308-14165	D- 3
4E5-26335-11	D- 6	90119-05001	B-13	90201-154E8	D- 8	90450-45075	B- 6	93306-00210	D- 3	94414-17530	C-15
4SS-26372-00	D- 7	90119-06063	C- 5	90201-161R1	D- 4	90450-99064	B- 6	93306-20117	C-15	94414-19521	C-15
498-26372-00	D- 6	90119-06118	C- 4	90201-176L4	B-12	90460-51059	B- 6	93306-20204	D- 3	94416-14529	D- 3
4E5-27114-00	D- 5	90119-06185	C- 5	90201-203E7	B-14	90464-16039	B- 6	93306-20333	B-14	94418-16522	D- 3
4E5-27211-00	D- 8	90119-06217	C- 6	90201-256K5	C-10	90467-08004	B- 5	93306-20421	B-14	94681-58001	D- 4
2YK-27222-00	D- 9		C- 6	90201-33299	B- 9	90467-10008	C-13	93306-20468	B- 3	94702-00367	B- 2
4E5-27311-00	D- 8	90119-06225	C-14	90202-05193	C-13	90467-11044	D- 9	93306-30421	B- 3	94702-00368	B- 2
4LB-27311-00	D- 8	90122-06038	B- 6	90208-12015	B-13	90468-23194	B-12	93310-214F8	B- 3	95021-10040	C-12
3LD-27411-00	D- 8	90123-08013	D- 6		B-13	90480-15528	B- 5		D-14	95027-06012	B- 9
4DA-27421-00	D- 8	90149-06011	C-13	90209-06096	B- 6	90480-16561	B- 9	93310-320T3	B- 3		B-12
4E5-27491-00	D- 5	90149-06272	D- 2	90209-06187	C- 5	90480-18411	B- 9		D-14		C-10
3CV-28371-00	C- 5		D- 5	90209-20159	B- 3	90480-18549	C-13	93315-11206	B-13		C-14
51L-28371-00	C-13	90157-05079	C-10		D-14	90501-12081	B-12	93315-21455	C- 7		D- 5
4KJ-82310-00	D-12	90157-06071	B-14	90240-08124	D- 9	90501-20735	B-13	93315-31502	B-14		D- 9

NUMERICAL INDEX

PART NO.	GRID NO.	PART NO.	GRID NO.	PART NO.	GRID NO.	PART NO.	GRID NO.	PART NO.	GRID NO.
95027-06014	C- 7	98707-04012	D- 7						
95027-06016	C- 5	98707-06025	C-13						
	C- 6	99006-10600	C- 3						
	C-12	99009-10400	C- 2						
	C-13	99009-12400	B-12						
	D- 9	99009-18400	B-15						
	D-12	99009-35500	D- 3						
95027-06020	B- 6	99080-07600	B- 4						
95027-06025	B- 4	99510-10114	B- 2						
	B- 9	99530-10014	B-10						
	B- 9		B-11						
95027-06030	B- 5								
	B-11								
	C-13								
95027-06040	B-11								
95027-08012	C- 4								
95027-08030	C-10								
95027-08080	B-11								
95307-08600	D- 9								
95307-08700	D- 4								
95317-10600	D-10								
95607-06100	D-11								
95607-08200	C- 4								
	C- 7								
95607-10200	C- 7								
95607-12200	C- 7								
95607-14200	D- 3								
95617-06100	D- 7								
95617-08100	D- 3								
95617-12100	C- 7								
95807-08035	C-10								
95817-08125	C- 4								
95817-08135	C- 4								
95827-06060	B- 4								
97007-05016	D-11								
97027-06020	C- 3								
97707-50014	B- 6								
97780-50110	D- 9								
98507-03008	B- 6								
98507-04018	B- 7								
98507-05016	D- 6								
98507-06016	D-10								
98507-06030	B-11								
98507-06040	B-10								
98507-06050	B-10								
98507-06060	B-10								
98580-03008	C-13								
98707-04012	D- 6								

[www.legends-yamaha-enduros.com](http://www.legends-yamaha-enduros.com)