



YAMAHA

OWNER'S SERVICE MANUAL

TZ125M1/(M)

LIT-11626-13-42

4JT-28199-16

www.legends-yamaha-enduros.com

EC010000

TZ125M1/(M)
OWNER'S SERVICE MANUAL
©1999 by Yamaha Motor Corporation, U.S.A.
1st Edition, August 1999
All rights reserved. Any reprinting or
unauthorized use without the written
permission of Yamaha Motor Corporation
U.S.A. is expressly prohibited.
Printed in Japan
P/N. LIT-11626-13-42

INTRODUCTION

Congratulations on your purchase of a Yamaha TZ series. This model is the culmination of Yamaha's vast experience in the production of pacesetting racing machines. It represents the highest grade of craftsmanship and reliability that have made Yamaha a leader.

This manual explains operation, inspection, basic maintenance and tuning of your machine. If you have any questions about this manual or your machine, please contact your Yamaha dealer.

NOTE:

As improvements are made on this model, some data in this manual may become outdated. If you have any questions, please consult your Yamaha dealer.

⚠WARNING

PLEASE READ THIS MANUAL CAREFULLY AND COMPLETELY BEFORE OPERATING THIS MACHINE. DO NOT ATTEMPT TO OPERATE THIS MACHINE UNTIL YOU HAVE ATTAINED A SATISFACTORY KNOWLEDGE OF ITS CONTROLS AND OPERATING FEATURES AND UNTIL YOU HAVE BEEN TRAINED IN SAFE AND PROPER RIDING TECHNIQUES. REGULAR INSPECTIONS AND CAREFUL MAINTENANCE, ALONG WITH GOOD RIDING SKILLS, WILL ENSURE THAT YOU SAFELY ENJOY THE CAPABILITIES AND THE RELIABILITY OF THIS MACHINE.

WARRANTY INFORMATION

This model is sold AS IS, WITHOUT ANY WARRANTIES EXPRESSED OR IMPLIED REGARDLESS OF THE INTENDED USE.

THE PURCHASER OF THIS MACHINE, which is intended for competition purposes, IS RESPONSIBLE FOR ALL COSTS, SERVICE AND/OR REPAIR.

IMPORTANT NOTICE

THIS MACHINE IS DESIGNED STRICTLY FOR COMPETITION USE, ONLY ON A CLOSED COURSE. It is illegal for this machine to be operated on any public street, road, or highway. Off-road use on public lands may also be illegal. Please check local regulations before riding.

⚠ SAFETY INFORMATION

- 1. THIS MACHINE IS TO BE OPERATED BY AN EXPERIENCED RIDER ONLY.**
Do not attempt to operate this machine at maximum power until you are totally familiar with its characteristics.
- 2. THIS MACHINE IS DESIGNED TO BE RIDDEN BY THE OPERATOR ONLY.**
Do not carry passengers on this machine.
- 3. ALWAYS WEAR PROTECTIVE APPAREL.**
When operating this machine, always wear an approved helmet with goggles or a face shield. Also wear heavy boots, gloves, and protective clothing. Always wear proper fitting clothing that will not be caught in any of the moving parts or controls of the machine.
- 4. ALWAYS MAINTAIN YOUR MACHINE IN PROPER WORKING ORDER.**
For safety and reliability, the machine must be properly maintained. Always perform the pre-operation checks indicated in this manual. Correcting a mechanical problem before you ride may prevent an accident.
- 5. GASOLINE IS HIGHLY FLAMMABLE.**
Always turn off the engine while refueling. Take care to not spill any gasoline on the engine or exhaust system. Never refuel in the vicinity of an open flame, or while smoking.

6. GASOLINE CAN CAUSE INJURY.

If you should swallow some gasoline, inhale excess gasoline vapors, or allow any gasoline to get into your eyes, contact a doctor immediately. If any gasoline spills onto your skin or clothing, immediately wash skin areas with soap and water, and change your clothes.

7. ONLY OPERATE THE MACHINE IN AN AREA WITH ADEQUATE VENTILATION.

Never start the engine or let it run for any length of time in an enclosed area. Exhaust fumes are poisonous. These fumes contain carbon monoxide, which by itself is odorless and colorless. Carbon monoxide is a dangerous gas which can cause unconsciousness or can be lethal.

8. PARK THE MACHINE CAREFULLY; TURN OFF THE ENGINE.

Always turn off the engine if you are going to leave the machine. Do not park the machine on a slope or soft ground as it may fall over.

9. PROPERLY SECURE THE MACHINE BEFORE TRANSPORTING IT.

When transporting the machine in another vehicle, always be sure it is properly secured and in an upright position and that the fuel cock is in the "OFF" position. Otherwise, fuel may leak out of the carburetor or fuel tank.

EC050000

TO THE NEW OWNER

This manual will provide you with a good basic understanding of features, operation, and basic maintenance and inspection items of this machine. Please read this manual carefully and completely before operating your new machine. If you have any questions regarding the operation or maintenance of your machine, please consult your Yamaha dealer.

NOTE:

This manual should be considered a permanent part of this machine and should remain with it even if the machine is subsequently sold.

EC060000

NOTICE

Some data in this manual may become outdated due to improvements made to this model in the future. If there is any question you have regarding this manual or your machine, please consult your Yamaha dealer.

EC070011

F.I.M. MACHINE WEIGHTS:

Weights of machines without fuel

The minimum weights for road race machines are:

for the class 125 ccminimum
70 kg (154 lb)

for the class 250 ccminimum
95 kg (209 lb)

for the class 500 ccminimum
131 kg (289 lb)

In modifying your machine (e.g., for weight reduction), take note of the above limits of weight.

HOW TO USE THIS MANUAL

PARTICULARLY IMPORTANT INFORMATION



The Safety Alert Symbol means ATTENTION! BECOME ALERT! YOUR SAFETY IS INVOLVED!

⚠ WARNING

Failure to follow WARNING instructions could result in severe injury or death to the machine operator, a bystander, or a person inspecting or repairing the machine.

CAUTION:

A CAUTION indicates special precautions that must be taken to avoid damage to the machine.

NOTE:

A NOTE provides key information to make procedures easier or clearer.

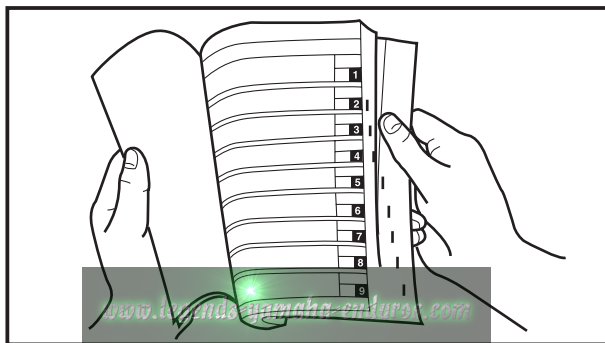

FINDING THE REQUIRED PAGE

1. This manual consists of seven chapters; “General Information”, “Specifications”, “Regular inspection and adjustments”, “Engine”, “Chassis”, “Electrical” and “Tuning”.
2. The table of contents is at the beginning of the manual. Look over the general layout of the book before finding then required chapter and item.

Bend the book at its edge, as shown, to find the required fore edge symbol mark and go to a page for required item and description.

MANUAL FORMAT

All of the procedures in this manual are organized in a sequential, step-by-step format. The information has been compiled to provide the mechanic with an easy to read, handy reference that contains comprehensive explanations of all disassembly, repair, assembly, and inspection operations. In this revised format, the condition of a faulty component will precede an arrow symbol and the course of action required will follow the symbol, e.g.,

- Bearings
Pitting/Damage → Replace.

HOW TO READ DESCRIPTIONS

To help identify parts and clarify procedure steps, there are exploded diagrams at the start of each removal and disassembly section.

1. An easy-to-see exploded diagram ① is provided for removal and disassembly jobs.
2. Numbers ② are given in the order of the jobs in the exploded diagram. A number that is enclosed by a circle indicates a disassembly step.
3. An explanation of jobs and notes is presented in an easy-to-read way by the use of symbol marks ③. The meanings of the symbol marks are given on the next page.
4. A job instruction chart ④ accompanies the exploded diagram, providing the order of jobs, names of parts, notes in jobs, etc.
5. Extent of removal ⑤ is provided in the job instruction chart to save the trouble of an unnecessary removal job.
6. For jobs requiring more information, the step-by-step format supplements ⑥ are given in addition to the exploded diagram and job instruction chart.

CLUTCH ENG

EC043000
CLUTCH HOUSING AND PUSH LEVER AXLE

①

②

③

④

⑤

Extend of removal: ① Clutch housing removal ② Push lever axle removal

Extend of removal	Order	Part name	Q'ty	Remarks
<div style="display: flex; flex-direction: column; align-items: center;"> <div style="margin-bottom: 10px;">①</div> <div style="margin-bottom: 10px;">②</div> </div>	1	CLUTCH HOUSING AND PUSH LEVER AXLE REMOVAL		
	2	Nut (clutch boss)	1	Use special tool. Refer to "REMOVAL POINTS".
	3	Lock washer	1	
	4	Clutch boss	1	
	5	Spacer Z	1	
	6	O-ring (small)	1	
	7	Clutch housing	1	
	8	O-ring (large)	1	
	9	Bearing	1	
	10	Spacer 1	1	
	11	Ball	1	
	12	Push rod	1	
	13	Bolt (seat plate)	1	
	14	Seat plate	1	
14	Push lever axle	1		

CLUTCH ENG

EC043000
REMOVAL POINTS

EC043011
Clutch boss

1. Remove:

- Nut ①
- Lock washer ②
- Clutch boss ③

NOTE:

Straighten the lock washer tab and use the clutch holding tool ④, ⑤ to hold the clutch boss.

	Clutch holding tool:
	YM-91042 ④
	90890-04086 ⑤

Ⓐ For USA and CDN
Ⓑ Except for USA and CDN

EC044000
INSPECTION

EC044005
Clutch housing and boss

1. Inspect:

- Clutch housing ①
- Cracks/Wear/Damage → Replace.
- Clutch boss ②
- Scoring/Wear/Damage → Replace.

EC044010
Clutch housing

1. Check:

- Circumferential play
- Free play exists → Replace.
- Gear teeth ③
- Wear/Damage → Replace.
- O-ring ④
- Damage → Replace.

EC044020
Clutch spring

1. Measure:

- Clutch spring free length ⑥
- Out of specification → Replace springs as a set.

	Clutch spring free length:
	Standard <Limit>
	36.0 mm (1.417 in) 35.0 mm (1.378 in)

4-25

4-26

www.legends-yamaha-enduros.com

ILLUSTRATED SYMBOLS (Refer to the illustration)

Illustrated symbols ① to ⑦ are designed as thumb tabs to indicate the chapter's number and content.

- ① General information
- ② Specifications
- ③ Regular inspection and adjustments
- ④ Engine
- ⑤ Chassis
- ⑥ Electrical
- ⑦ Tuning

Illustrated symbols ⑧ to ⑭ are used to identify the specifications appearing in the text.















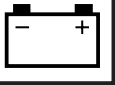

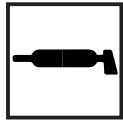

- ⑧ With engine mounted
- ⑨ Special tool
- ⑩ Filling fluid
- ⑪ Lubricant
- ⑫ Tightening
- ⑬ Specified value, Service limit
- ⑭ Resistance (Ω), Voltage (V), Electric current (A)

Illustrated symbols ⑮ to ⑲ in the exploded diagrams indicate grade of lubricant and location of lubrication point.

- ⑮ Apply transmission oil
- ⑯ Apply engine mixing oil
- ⑰ Apply molybdenum disulfide oil
- ⑱ Apply lightweight lithium-soap base grease
- ⑲ Apply molybdenum disulfide grease







Illustrated symbols ⑳ to ㉑ in the exploded diagrams indicate where to apply a locking agent and where to install new parts.

- ㉑ Apply locking agent (LOCTITE®)
- ㉒ Use new one

① GEN INFO 	② SPEC 	
③ INSP ADJ 	④ ENG 	
⑤ CHAS 	⑥ ELEC 	
⑦ TUN 	⑧ 	
⑨ 	⑩ 	
⑪ 	⑫ 	
⑬ 	⑭ 	
⑮ 	⑯ 	⑰ 
⑱ 	⑲ 	
㉑ 	㉒ New	

MEMO

INDEX

GENERAL INFORMATION	
	GEN INFO 1
SPECIFICATION	
	SPEC 2
REGULAR INSPECTION AND ADJUSTMENTS	
	INSP ADJ 3
ENGINE	
	ENG 4
CHASSIS	
	CHAS 5
ELECTRICAL	
	ELEC 6
TUNING	
	TUN 7

CONTENTS

CHAPTER 1 GENERAL INFORMATION

DESCRIPTION..... 1-1
MACHINE IDENTIFICATION 1-2
IMPORTANT INFORMATION 1-3
CHECKING OF CONNECTION 1-5
SPECIAL TOOLS..... 1-6
CONTROL FUNCTIONS 1-9
FUEL AND ENGINE MIXING OIL..... 1-14
INFORMATION BEFORE
PRE-OPERATION 1-15
STARTING AND BREAK-IN..... 1-16
TORQUE-CHECK POINTS..... 1-19
CLEANING AND STORAGE 1-20

CHAPTER 2 SPECIFICATIONS

GENERAL SPECIFICATIONS 2-1
MAINTENANCE SPECIFICATIONS..... 2-3
GENERAL TORQUE SPECIFICATIONS. 2-11
DEFINITION OF UNITS 2-11
CABLE ROUTING DIAGRAM 2-12

CHAPTER 3 REGULAR INSPECTION AND ADJUSTMENTS

MAINTENANCE INTERVALS..... 3-1
PRE-OPERATION INSPECTION AND
MAINTENANCE..... 3-4
LOCKING WIRE INSTALLATION GUIDE. 3-5
ENGINE..... 3-6
CHASSIS..... 3-13
ELECTRICAL..... 3-37

CHAPTER 4 ENGINE

COWLING, SEAT AND FUEL TANK	4-1
EXHAUST PIPE AND SILENCER	4-3
RADIATOR	4-4
CARBURETOR AND REED VALVE	4-7
CYLINDER HEAD, CYLINDER AND PISTON	4-17
CLUTCH	4-27
PRIMARY DRIVEN GEAR, PRIMARY DRIVE GEAR AND BALANCER SHAFT	4-35
SHIFT SHAFT AND OIL PUMP	4-42
TRANSMISSION, SHIFT CAM AND SHIFT FORK	4-48
CDI MAGNETO	4-58
ENGINE REMOVAL	4-61
CRANKCASE, CRANKSHAFT AND WATER PUMP	4-65

CHAPTER 5 CHASSIS

FRONT WHEEL AND REAR WHEEL	5-1
FRONT BRAKE AND REAR BRAKE	5-9
FRONT FORK	5-25
HANDLEBAR	5-39
STEERING	5-44
SWINGARM	5-51
REAR SHOCK ABSORBER	5-58

CHAPTER 6 ELECTRICAL

ELECTRICAL COMPONENTS AND WIRING DIAGRAM	6-1
IGNITION SYSTEM	6-2
SOLENOID VALVE SYSTEM	6-6
THERMO UNIT SYSTEM	6-9

CHAPTER 7 TUNING

ENGINE	7-1
CHASSIS	7-14



EC100000

GENERAL INFORMATION

EC110000

DESCRIPTION

- ① Clutch lever
- ② "ENGINE STOP" button
- ③ Water temperature gauge
- ④ Front brake lever
- ⑤ Throttle grip
- ⑥ Radiator cap
- ⑦ Fuel tank cap
- ⑧ Valve joint
- ⑨ Front fork
- ⑩ Radiator
- ⑪ Check bolt (Transmission oil level)
- ⑫ Rear brake pedal
- ⑬ Steering damper
- ⑭ Fuel cock
- ⑮ Rear shock absorber
- ⑯ Drive chain
- ⑰ Shift pedal
- ⑱ Starter knob
- ⑲ CDI magneto

NOTE:

- The machine you have purchased may differ slightly from those shown in the following.
- Designs and specifications are subject to change without notice.

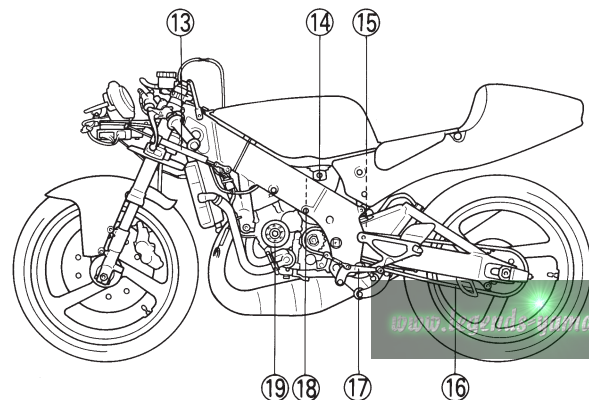
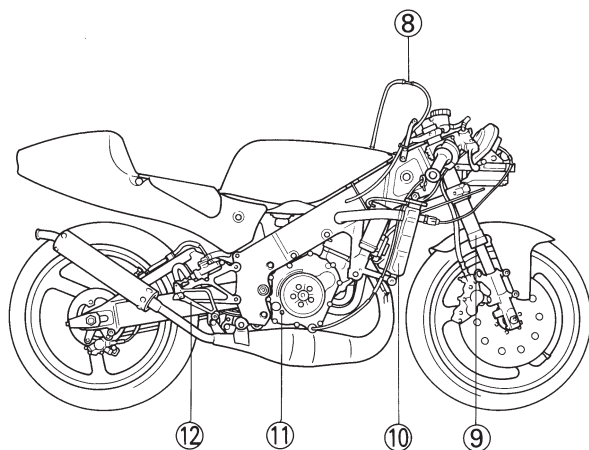
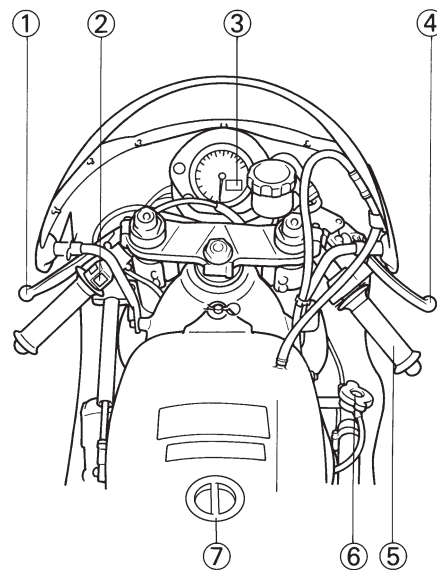

EC120001

MACHINE IDENTIFICATION

There are two significant reasons for knowing the serial number of your machine:

1. When ordering parts, you can give the number to your Yamaha dealer for positive identification of the model you own.
2. If your machine is stolen, the authorities will need the number to search for and identify your machine.

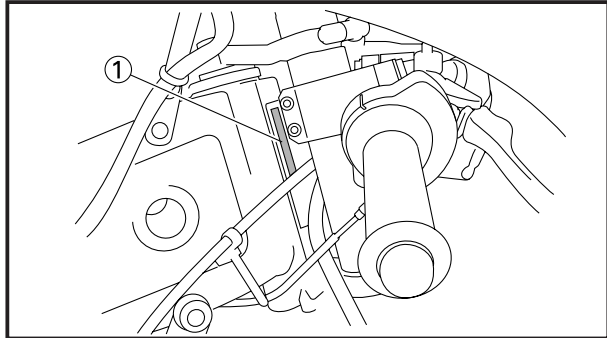

EC121001

**VEHICLE IDENTIFICATION NUMBER
(For USA, CDN, AUS, NZ and E)**

The vehicle identification number ① is stamped on the right of the steering head pipe.

EC122001

**FRAME SERIAL NUMBER
(Except for USA, CDN, AUS, NZ and E)**

The frame serial number ① is stamped on the right of the steering head pipe.

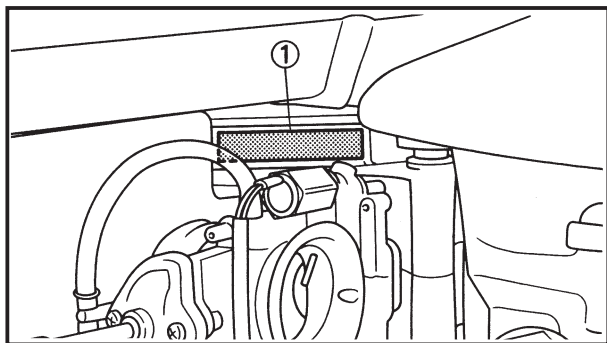

EC123001

ENGINE SERIAL NUMBER

The engine serial number ① is stamped into the elevated part of the right-side of the engine.

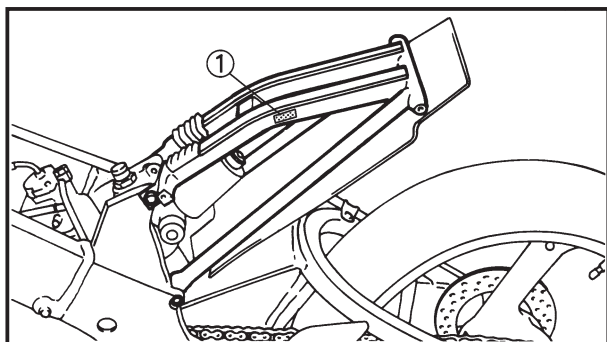

EC124000

MODEL LABEL

The model label ① is affixed to the frame under the rider's seat. This information will be needed to order spare parts.

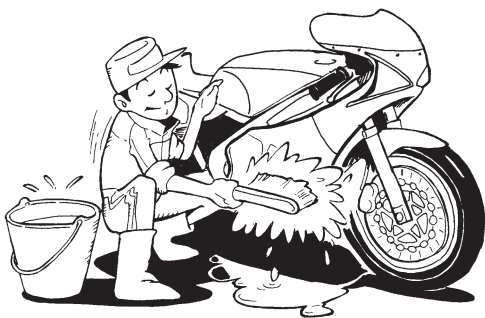

EC130000

IMPORTANT INFORMATION

EC131002

PREPARATION FOR REMOVAL AND DISASSEMBLY

1. Remove all dirt, mud, dust, and foreign material before removal and disassembly.

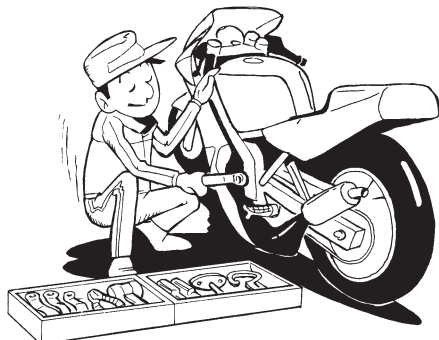

2. Use proper tools and cleaning equipment. Refer to "SPECIAL TOOLS" section.



3. When disassembling the machine, keep mated parts together. They include gears, cylinders, pistons, and other mated parts that have been "mated" through normal wear. Mated parts must be reused as an assembly or replaced.



4. During the machine disassembly, clean all parts and place them in trays in the order of disassembly. This will speed up assembly time and help assure that all parts are correctly reinstalled.



5. Keep away from fire.

EC132000

ALL REPLACEMENT PARTS

1. We recommend to use Yamaha genuine parts for all replacements. Use oil and/or grease recommended by Yamaha for assembly and adjustment.

EC133000

GASKETS, OIL SEALS AND O-RINGS

1. All gaskets, oil seals, and O-rings should be replaced when an engine is overhauled. All gasket surfaces, oil seal lips, and O-rings must be cleaned.
2. Properly oil all mating parts and bearings during reassembly. Apply grease to the oil seal lips.

EC134000

LOCK WASHERS/PLATES AND COTTER PINS

1. All lock washers/plates ① and cotter pins must be replaced when they are removed. Lock tab(s) should be bent along the bolt or nut flat(s) after the bolt or nut has been properly tightened.

EC135001

BEARINGS AND OIL SEALS

1. Install the bearing(s) ① and oil seal(s) ② with their manufacturer's marks or numbers facing outward. (In other words, the stamped letters must be on the side exposed to view.) When installing oil seal(s), apply a light coating of light-weight lithium base grease to the seal lip(s). Oil the bearings liberally when installing.

CAUTION:

Do not use compressed air to spin the bearings dry. This causes damage to the bearing surfaces.

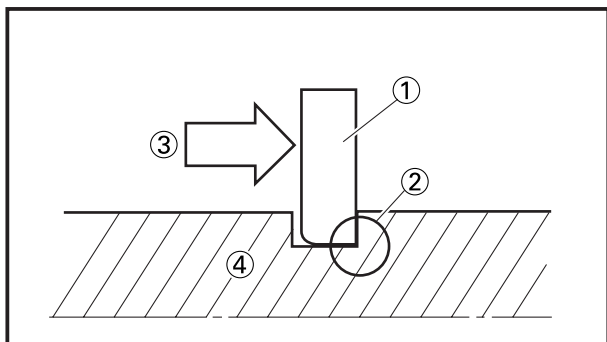
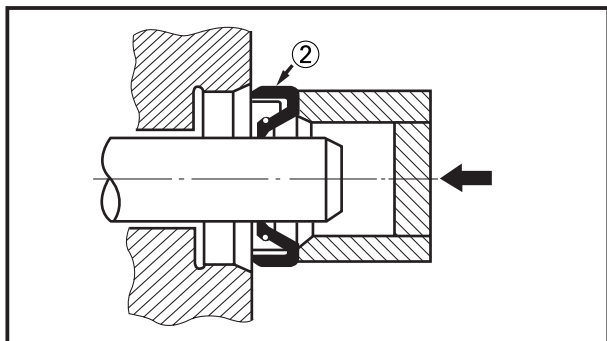
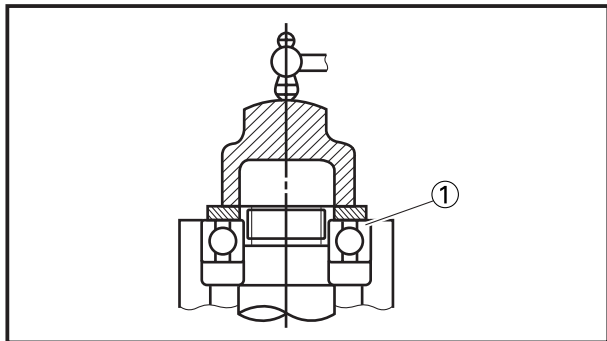
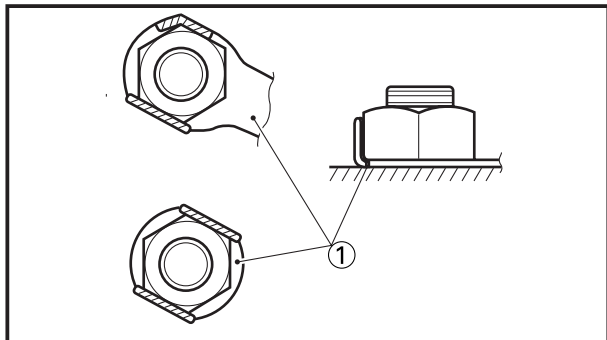

EC136000

CIRCLIPS

1. All circlips should be inspected carefully before reassembly. Always replace piston pin clips after one use. Replace distorted circlips. When installing a circlip ①, make sure that the sharp-edged corner ② is positioned opposite to the thrust ③ it receives. See the sectional view.

④ Shaft

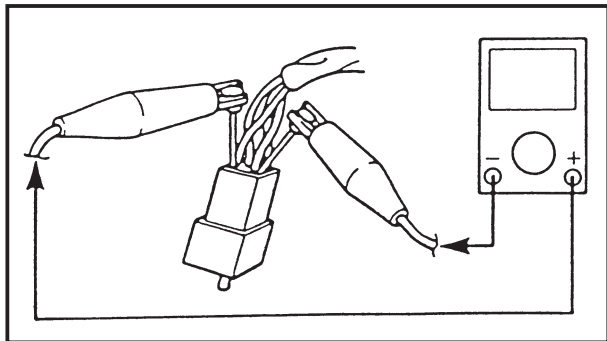
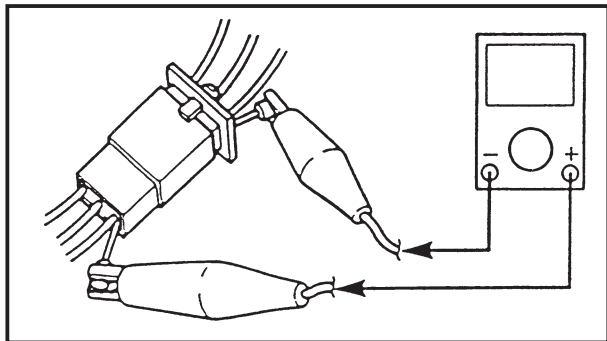
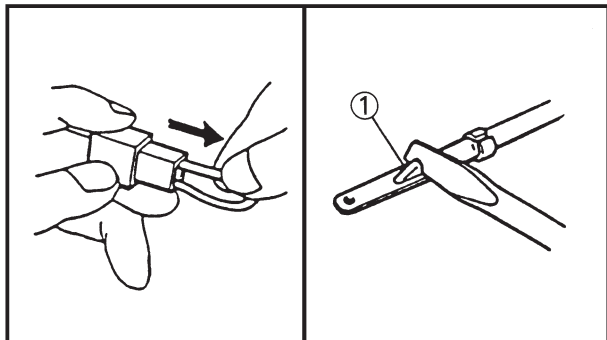
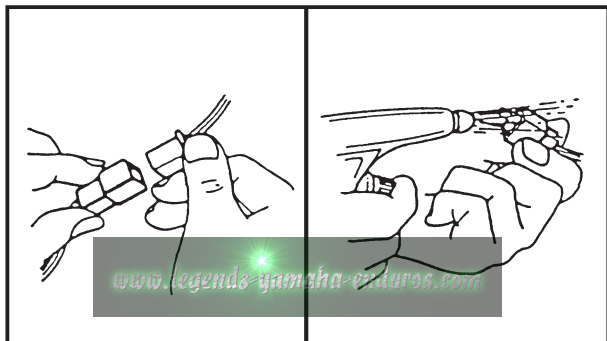

EC1C0001

CHECKING OF CONNECTION

Dealing with stains, rust, moisture, etc. on the connector.

1. Disconnect:
 - Connector
2. Dry each terminal with an air blower.
3. Connect and disconnect the connector two or three times.
4. Pull the lead to check that it will not come off.
5. If the terminal comes off, bend up the pin ① and reinsert the terminal into the connector.

6. Connect:
 - Connector

NOTE: _____
The two connectors “click” together.

7. Check for continuity with a tester.

- NOTE:** _____
- If there is no continuity, clean the terminals.
 - Be sure to perform the steps 1 to 7 listed above when checking the wireharness.
 - For a field remedy, use a contact revitalizer available on the market.
 - Use the tester on the connector as shown.





EC140001



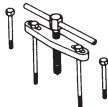
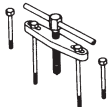
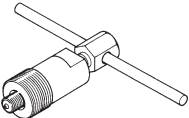
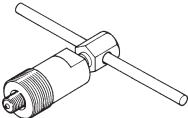
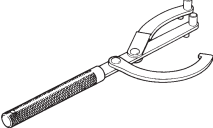
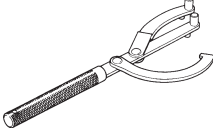

SPECIAL TOOLS

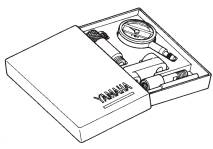
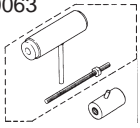
The proper special tools are necessary for complete and accurate tune-up and assembly. Using the correct special tool will help prevent damage caused by the use of improper tools or improvised techniques. The shape and part number used for the special tool differ by country, so two types are provided. Refer to the list provided to avoid errors when placing an order.

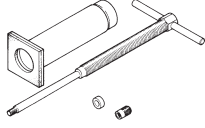
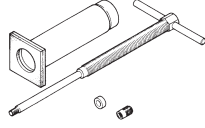
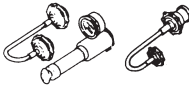
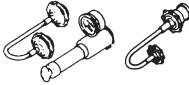
NOTE:

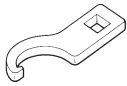
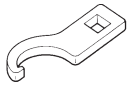
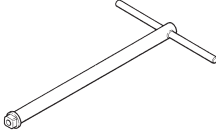
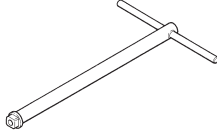
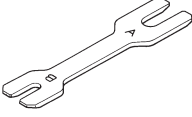
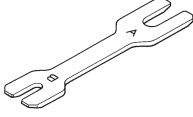
- For U.S.A. and Canada, use part number starting with “YM-” or “YU-”.
- For others, use part number starting with “90890-”.

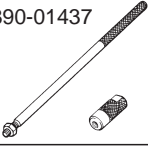
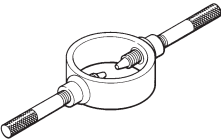
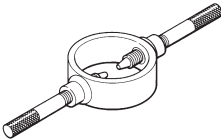
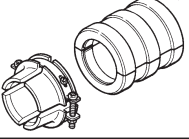
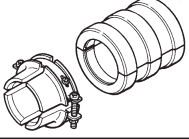
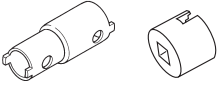
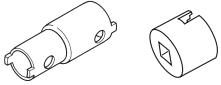
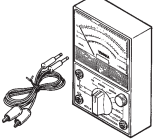
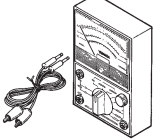
Part number	Tool name / How to use	Illustration	
YU-01135-A, 90890-01135 YM-01305, 90890-01305	Crankcase separating tool Crankcase separating bolt These tools are used to split the crankcase as well as remove the crankshaft from either case.	YU-01135-A YM-01305 	90890-01135 90890-01305 
YM-01189, 90890-01189	Flywheel puller This tool is used to remove the flywheel magneto.	YM-01189 	90890-01189 
YU-01235, 90890-01235	Rotor holding tool This tool is used when loosening or tightening the flywheel magneto securing nut.	YU-01235 	90890-01235 
YU-03097, 90890-01252 YU-01256	Dial gauge and stand Stand These tools are used to set the ignition timing.	YU-03097 YU-01256 	90890-01252 
YU-90050, 90890-01274 YU-90050, 90890-01275 YU-90063, 90890-01278	Crankcase installing tool Pot Bolt Adapter These tools are used to install the crankshaft.	YU-90050 YU-90063 	90890-01274 90890-01275 90890-01278 
YU-01304, 90890-01304	Piston pin puller This tool is used to remove the piston pin.	YU-01304 	90890-01304 
YU-24460-1, 90890-01325 YU-33984, 90890-01352	Radiator cap tester Adapter These tools are used for checking the cooling system.	YU-24460-1 YU-33984 	90890-01325 90890-01352 

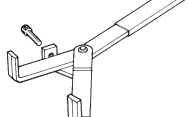
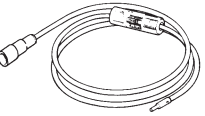
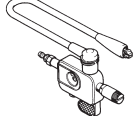
Part number	Tool name / How to use	Illustration	
YM-33975, 90890-01403	<p>Ring nut wrench</p> <p>This tool is used when tighten the steering ring nut to specification.</p>	<p>YM-33975</p> 	<p>90890-01403</p> 
YM-01425, 90890-01425	<p>Damper rod holder</p> <p>Use this tool to remove and install the damper rod.</p>	<p>YM-01425</p> 	<p>90890-01425</p> 
YM-01434, 90890-01434	<p>Rod holder</p> <p>This tool is used to hold the fork spring.</p>	<p>YM-01434</p> 	<p>90890-01434</p> 
90890-01436 YM-01437, 90890-01437	<p>Rod puller attachment</p> <p>Rod puller</p> <p>These tools are used to pull up the fork damper rod.</p>	<p>YM-01437</p> 	<p>90890-01436 90890-01437</p> 
YM-01441, 90890-01441	<p>Fork spring compressor</p> <p>This tool is used to compress the fork spring.</p>	<p>YM-01441</p> 	<p>90890-01441</p> 
YM-01442, 90890-01442	<p>Fork seal driver</p> <p>This tool is used when install the fork oil seal.</p>	<p>YM-01442</p> 	<p>90890-01442</p> 
YM-01455, 90890-01455 YM-01476, 90890-01476	<p>Pivot shaft wrench</p> <p>Pivot shaft wrench adapter</p> <p>These tools are used to loosen or tighten the pivot adjust bolt.</p>	<p>YM-01455 YM-01476</p> 	<p>90890-01455 90890-01476</p> 
YU-03112, 90890-03112	<p>Yamaha pocket tester</p> <p>Use this tool to inspect the coil resistance, output voltage and amperage.</p>	<p>YU-03112</p> 	<p>90890-03112</p> 
YM-91042, 90890-04086	<p>Clutch holding tool</p> <p>This tool is used to hold the clutch when removing or installing the clutch boss securing nut.</p>	<p>YM-91042</p> 	<p>90890-04086</p> 
YM-34487 90890-06754	<p>Dynamic spark tester</p> <p>Ignition checker</p> <p>This instrument is necessary for checking the ignition system components.</p>	<p>YM-34487</p> 	<p>90890-06754</p> 

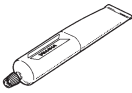
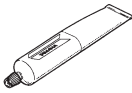
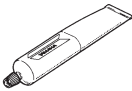
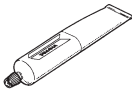
Part number	Tool name / How to use	Illustration	
ACC-11001-05-01 90890-85505	Quick gasket® YAMAHA Bond No. 1215 This sealant (Bond) is used for crankcase mating surface, etc.	ACC-11001-05-01 	90890-85505 
ACC-11001-30-00 90890-05143	Quick gasket® YAMAHA Bond No.4 This sealant (Bond) is used for crankcase mating surface, etc.	ACC-11001-30-00 	90890-05143 

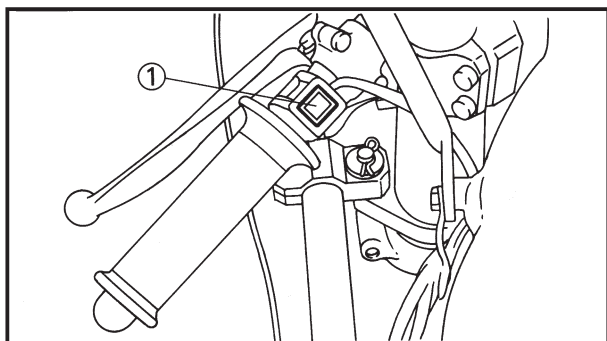

EC150000

CONTROL FUNCTIONS

EC151000

“ENGINE STOP” BUTTON

The “ENGINE STOP” button ① is located on the left handlebar. Continue pushing the “ENGINE STOP” button till the engine comes to a stop.

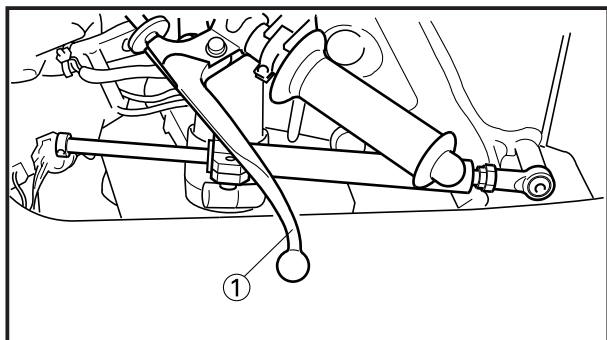

EC152000

CLUTCH LEVER

The clutch lever ① is located on the left handlebar; it disengages or engages the clutch. Pull the clutch lever to the handlebar to disengage the clutch, and release the lever to engage the clutch. The lever should be pulled rapidly and released slowly for smooth starts.

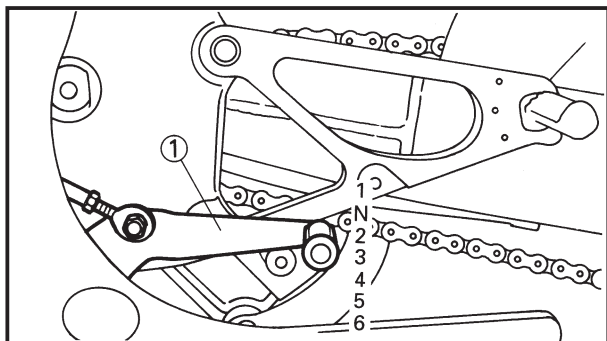

EC153000

SHIFT PEDAL

The gear ratios of the constant-mesh 6 speed transmission are ideally spaced. The gears can be shifted by using the shift pedal ① on the left side of the engine.

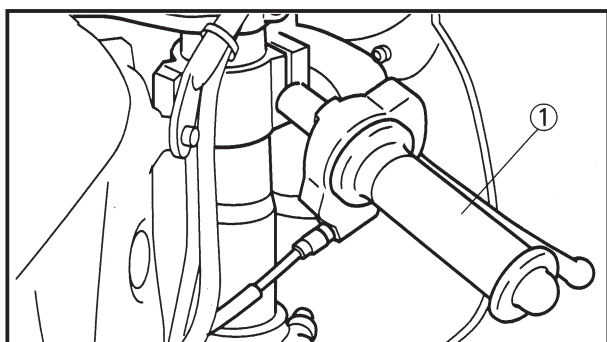

EC155001

THROTTLE GRIP

The throttle grip ① is located on the right handlebar; it accelerates or decelerates the engine. For acceleration, turn the grip toward you; for deceleration, turn it away from you.

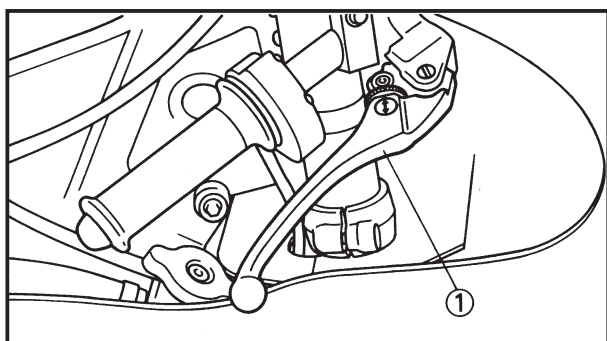

EC156000

FRONT BRAKE LEVER

The front brake lever ① is located on the right handlebar. Pull it toward the handlebar to activate the front brake.

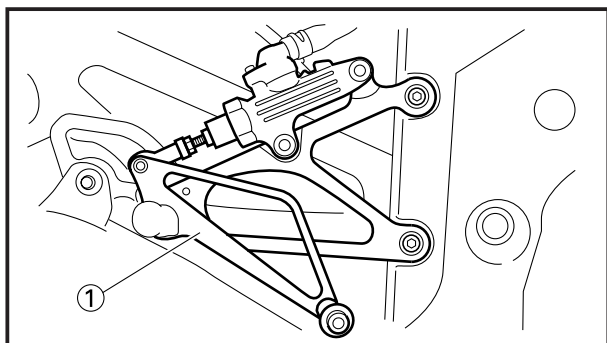

EC157000

REAR BRAKE PEDAL

The rear brake pedal ① is located on the right side of the machine. Press down on the brake pedal to activate the rear brake.

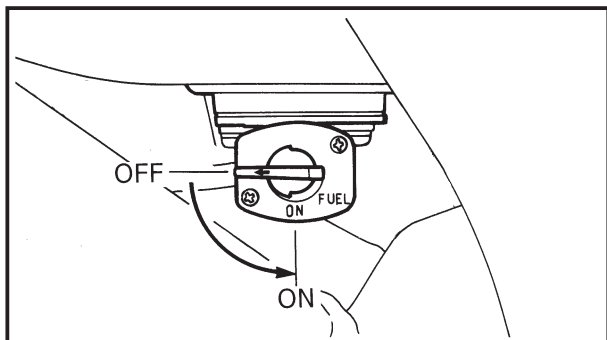

EC158001

FUEL COCK

The fuel cock supplies fuel from the tank to carburetor while filtering the fuel. The fuel cock has the two positions:

OFF: With the lever in this position, fuel will not flow. Always return the lever to this position when the engine is not running.

ON: With the lever in this position, fuel flows to the carburetor. Normal riding is done with the lever in this position.

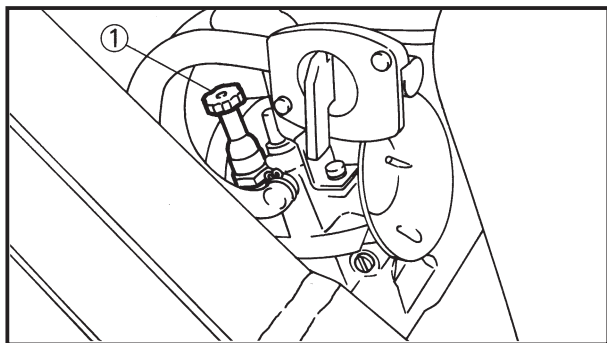

EC159000

STARTER KNOB (CHOKE)

When cold, the engine requires a richer air-fuel mixture for starting. A separate starter circuit, which is controlled by the starter knob ①, supplies this mixture. Pull the starter knob out to open the circuit for starting. When the engine has warmed up, push it in to close the circuit.

EC15V000

TACHOMETER

A stepping motor type tachometer is provided for greater accuracy of the tachometer ①. This tachometer features the following:

Sweeping:

After the engine is started, the tachometer hand sweeps widely once over the tachometer face and then returns to the zero position, as initial operation. This is called "sweeping". After that, the tachometer indicates the correct revolutions.

Out-of-step indication:

If this tachometer is subjected to impact, etc, it may allow its hand to point to the position ⑥ stepping out of the position ⑤ where the hand should be for correct indication. This is called an "out-of-step" indication. A similar phenomenon may take place when the engine is stopped during sweeping or at high rpm (as in a plug chop) or while the machine is transported, though it never happens in normal riding.

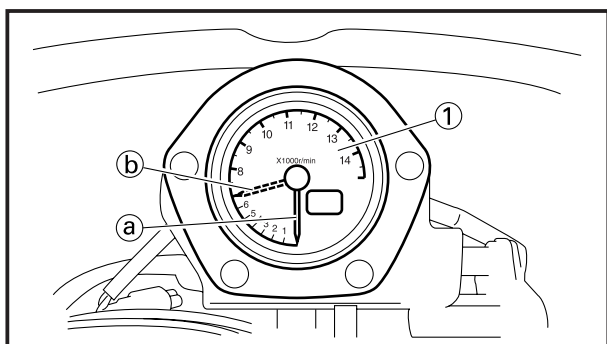



NOTE:

- If an out-of-step indication takes place, restarting the engine brings the tachometer back to a normal indication through its corrective action.
- There is no functional problem involved with the out-of-step indication, which can be brought back to a normal indication through the corrective action of the tachometer.

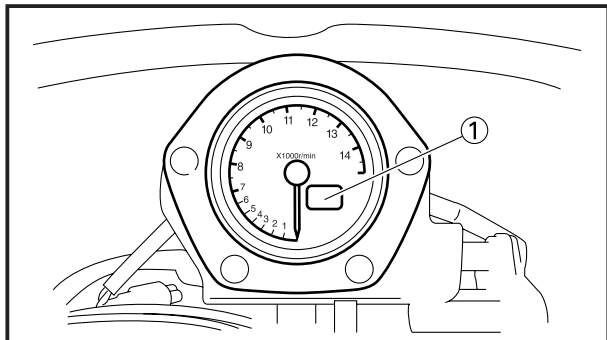

EC15B010

WATER TEMPERATURE GAUGE

The water temperature gauge ① displays different indications according to the change in the water temperature.

NOTE:

Water temperature may be 60 °C (140 °F) when engine is operated in good conditions.

Cooling water temp.	Display	Conditions
~19 °C (~66 °F)	LO	“LO” is display.
20~119 °C (68~247 °F)	60	Temperature is displayed.
120~140 °C (248~284 °F)	130	Temperature flash.
141 °C~ (285 °F~)	HI	Message “HI” flash.

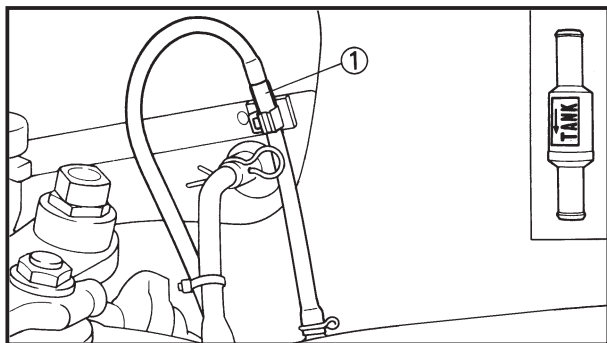

EC15F000

VALVE JOINT

This valve joint ① prevents fuel from flowing out and is installed to the fuel tank breather hose.

CAUTION:

In this installation, make sure the arrow faces the fuel tank and also downward.

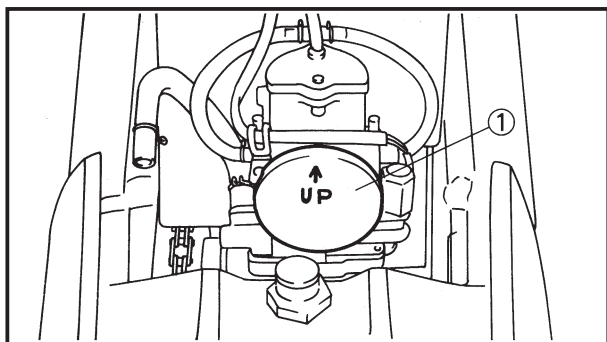

EC15G000

MIXING COVER

The mixing cover ① is installed to prevent dust, etc. from entering the carburetor. Remove this cover before starting the engine.

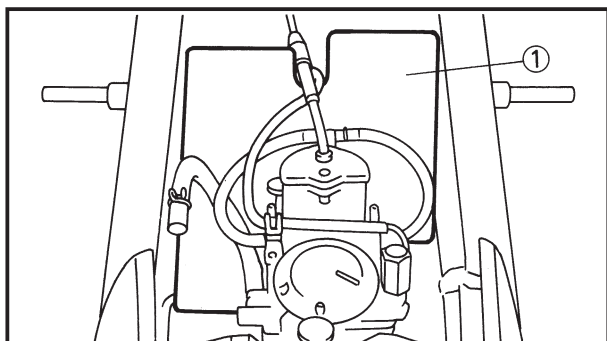

EC15H000

CARBURETOR COVER

The carburetor cover ① is provided for carburetor space.

CAUTION: _____

If the machine is run without this cover, the carburetor settings will become faulty.

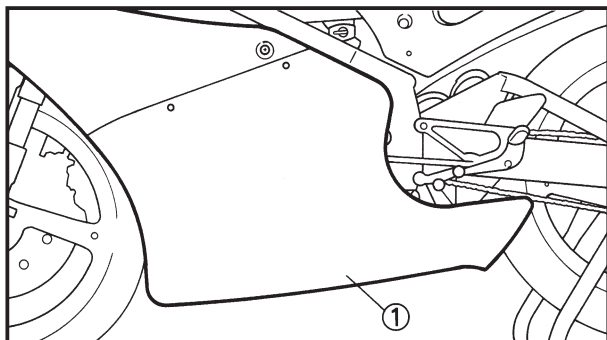

EC15L000

LOWER COWL

Make sure that the lower cowl ① is installed before riding the machine.

CAUTION: _____

If the machine is run without lower cowl, the carburetor settings will become faulty.

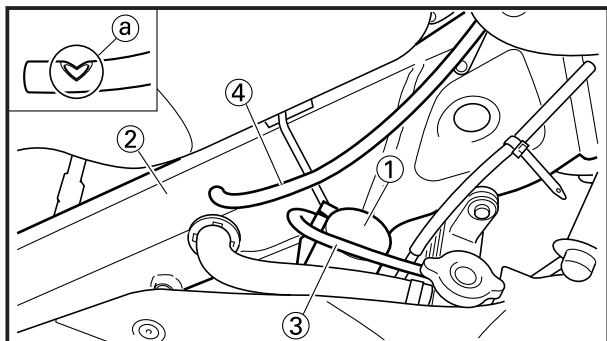

EC15M001

CATCH TANK

Put the tip of the breather hose into the catch tank ① and frame ②. Take care not to allow the fuel, oil and cooling water to spill on the course.

- ③ Radiator breather hose
- ④ Fuel tank breather hose
- ⑤ Transmission oil breather hose

NOTE: _____

When putting in the fuel tank breather hose, its tip having a cut ④ should be on the frame side.

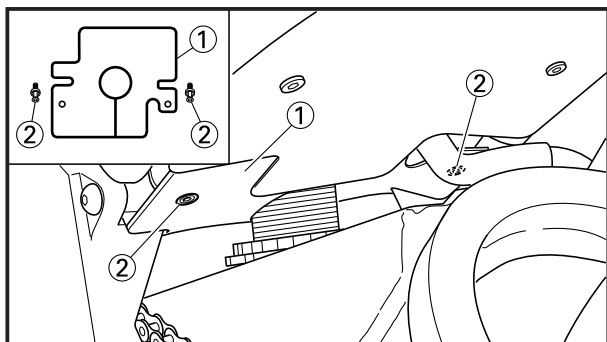
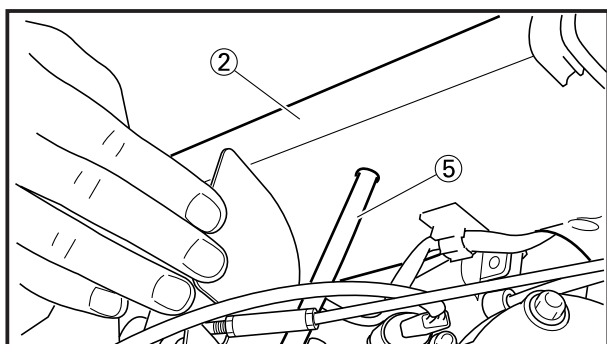

EC15N000

FLAP

When running in rainy weather, fit this flap ① to the rear frame with the screw ② to prevent water from entering the carburetor.

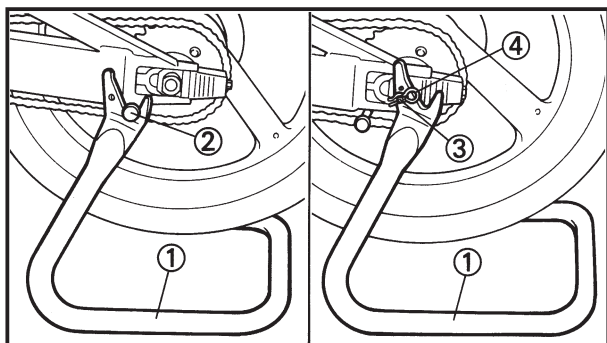

EC15Q001

DETACHABLE MAINSTAND

This mainstand ① is used to support only the machine when standing or transporting it.

NOTE:

The mainstand can be used to support the machine two ways.

1. Hook the bracket of the mainstand onto the swingarm hooks ②.
2. Stand shaft (with supplying parts):
Insert the stand shaft ③ through the hole of the mainstand and rear wheel axle. Be sure to install the clip ④ in the end of the stand shaft.

⚠WARNING

- Never apply additional force to the mainstand.
- Remove this mainstand before starting out.

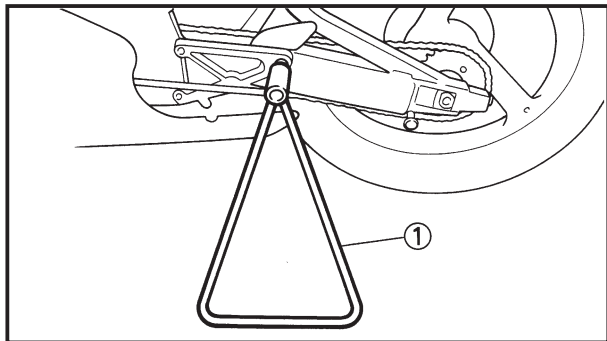

EC15R001

DETACHABLE SIDESTAND

This sidestand ① is used to support only the machine when standing or transporting it.

⚠WARNING

- Never apply additional force to the sidestand.
- Remove this sidestand before starting out.

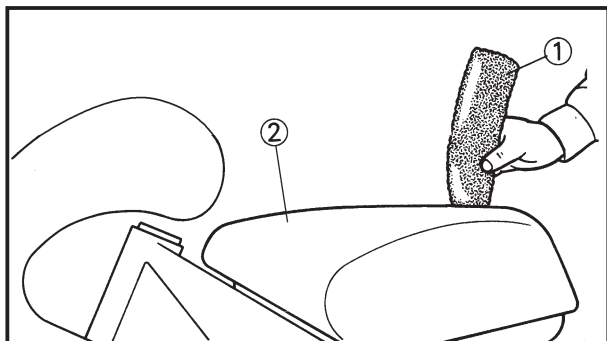

EC15T003

FIRE RETARDANT MATERIAL

For racing, be sure to fill the fuel tank ② completely with fire retardant material (with supplying parts) ①.



EC160040

FUEL AND ENGINE MIXING OIL

Mix oil with the gas at the ratio specified below. Always use fresh, name-brand gasoline, and mix the oil and gas the day of the race. Do not use premix that is more than a few hours old.

	Recommended fuel:
	Except for AUS:
	Premium unleaded fuel with a research octane number of 95 or higher.
	For AUS:
	Unleaded fuel only

NOTE: _____

Except for AUS:

1. If knocking or pinging occurs, use a different brand of gasoline or higher octane grade.
2. If unleaded gasoline is not available, then leaded gasoline can be used.

CAUTION: _____

Never mix two types of oil in the same batch; clotting of the oil could result. If you wish to change oil types, be sure to drain the fuel tank and the carburetor float bowl of old premix prior to filling with the new type.

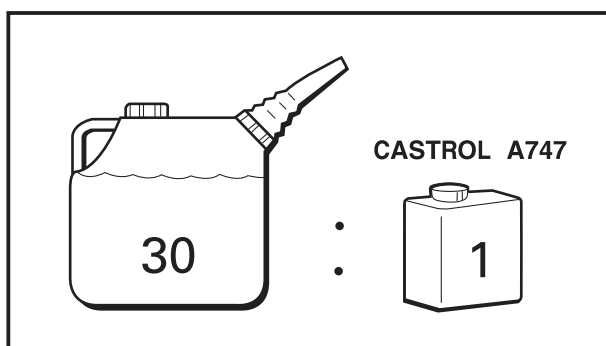

	Fuel tank capacity:
	13.0 L (2.86 Imp gal, 3.43 US gal)

	Mixing oil
	Recommended oil:
	Castrol A747
	Mixing ratio: 30 : 1

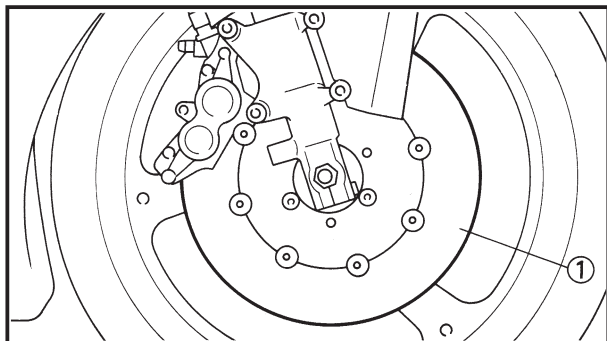

EC170011

INFORMATION BEFORE PRE-OPERATION

1. The brake disc ① is coated with a rust inhibitor. Before riding the machine, thoroughly remove it using a lacquer thinner.

⚠WARNING

- **LACQUER THINNER IS HIGHLY FLAMMABLE.**

Always turn off the engine while using lacquer thinner. Take care not to spill any lacquer thinner on the engine or exhaust system.

Never use it in the vicinity of an open flame, or while smoking.

- **LACQUER THINNER CAN CAUSE INJURY.** Always use lacquer thinner in a well ventilated area. If you should swallow some lacquer thinner, inhale excess lacquer thinner vapors, or allow any lacquer thinner to get into your eyes, contact a doctor immediately.

NOTE:

- When the machine is not in use for a long time, apply a rust inhibitor to the brake disc.
- After riding in the rainy weather, wipe the moisture completely off the disc.
- If rust appears on the brake disc, carefully remove it using #400 sand paper.

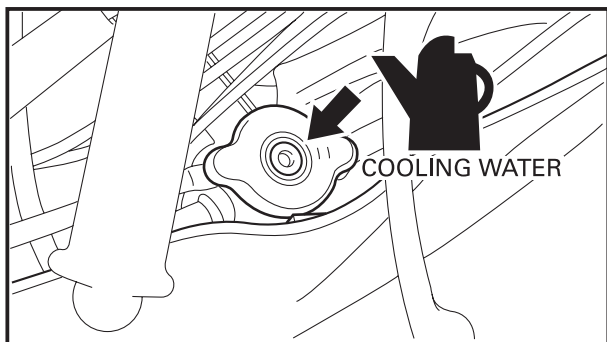

2. The cooling system is filled with coolant at the factory to prevent rusting. Be sure to replace coolant with soft water before riding.

CAUTION:

Hard water or salt water is harmful to the engine parts. You may use distilled water, if you can't get soft water.



EC190000

STARTING AND BREAK-IN**CAUTION:** _____

Before starting the machine, perform the checks in the pre-operation check list.

⚠ WARNING _____

Never start or run the engine in a closed area. The exhaust fumes are poisonous; they can cause loss of consciousness and death in a very short time. Always operate the machine in a well-ventilated area.

EC191020

STARTING A COLD ENGINE

1. Turn the fuel cock to "ON" and pull the starter knob (CHOKE).
2. Shift the transmission into "1st" gear.
3. Apply the clutch lever and push the machine.
4. After gaining some momentum, release the clutch lever.
5. As soon as the engine starts, quickly apply the clutch lever again and open the throttle grip slightly at the same time so as to sustain idling of the engine. Then, shift the transmission into neutral.
6. After applying full-throttle a few times, push the starter knob (CHOKE) to the original position. Take some time to allow the engine to warm up.

EC192000

WARMING UP

Run the engine at varying speeds 5,000~6,000 r/min for 1~2 minutes. Fully warm up until the water temperature gauge reads 60 °C (140 °F) or so.

CAUTION: _____

Do not warm up the engine for extended periods.



EC193021

STARTING A WARM ENGINE

Do not pull the starter knob (CHOKE). Open the throttle slightly and start the engine.

CAUTION: _____

Observe the following break-in procedure during initial operation to ensure optimum performance and avoid engine damage.

EC194013

BREAK-IN PROCEDURES

1. Before starting the engine, fill the fuel tank with a break-in oil-fuel mixture as follows.

**Mixing oil****Recommended oil:****Castrol A747****Mixing ratio: 30 : 1**

2. Perform the pre-operation checks on the machine.
3. Start and warm up the engine. Check the operation of the controls and the "ENGINE STOP" button.

NOTE: _____

During break-in, mask part of the radiator core so that the water temperature is 60 ~ 65°C (140 ~ 149°F).

4. Operate the machine under 8,000 r/min and run on a course about 10 km (6 miles). While making a straight-line run, open the throttle from time to time, taking care not to exceed the revolution limit.
5. Go back to the pit to check for looseness, leakage, and other failures in installation.
6. Next, operate the machine under 9,000 r/min and run about 10 km (6 miles). (While running in this way, get an idea of the riding position and approximate settings.)
7. Go back to the pit again, check the machine fully for looseness, leakage, and other failures in installation, especially for loose cables and wires, excessive brake free play, and a chain slack. Also make adjustment for a riding position according to your preference.

CAUTION:

After the break-in or before each race, you must check the entire machine for loose fittings and fasteners as per “TORQUE-CHECK POINTS”.

Tighten all such fasteners as required.

8. Increase the engine speed up to 10,000 r/min and run about 10 km (6 miles).
9. Increase the engine speed up to 11,000 r/min and run about 10 km (6 miles).
10. Increase the engine speed up to 12,000 r/min and run about 10 km (6 miles). Then do the plug chop. Check the piston head for burning to see if there is any problem. Refer to “SETTING” section in the CHAPTER 7.
11. Run about 10 km (6 miles) in a usual manner. Then do the plug chop. Check the piston head for burning to see if there is any problem.

EC195001

BREAKING IN AFTER REPLACEMENT

After a part is replaced with a new one, it is necessary to break it in as in a new machine.

This is required especially when the following engine-related parts are replaced.

- Cylinder
- Piston
- Piston ring
- Crankshaft
- Clutch
- Transmission gear
- Shift fork

※ For warming up and inspection during break-in, refer to “PRE-OPERATION CHECK LIST” and if there is any problem, stop the engine immediately and check.

EC1A0032

TORQUE-CHECK POINTS

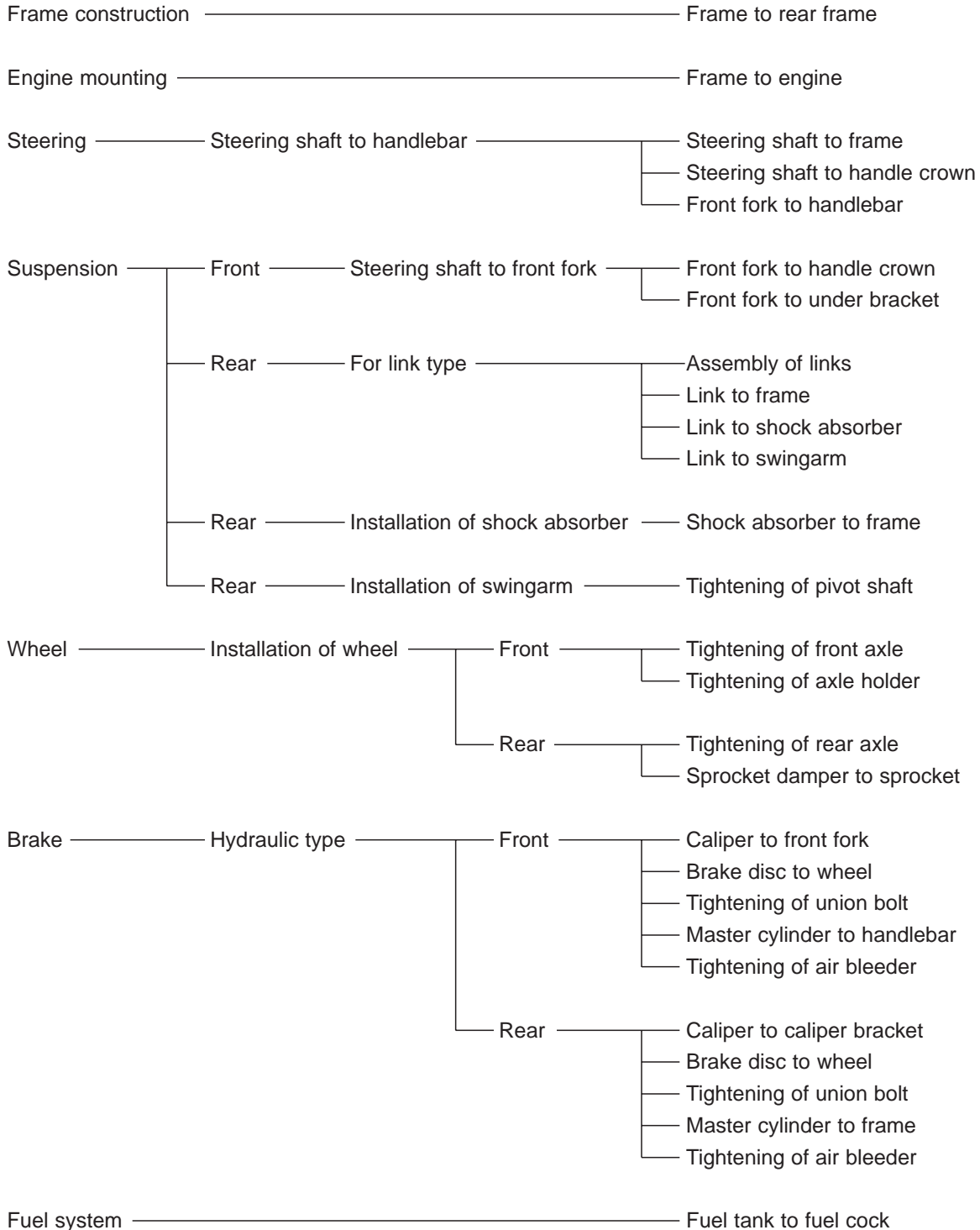

NOTE: Concerning the tightening torque, refer to “MAINTENANCE SPECIFICATIONS” section in the CHAPTER 2.

EC1B0000

CLEANING AND STORAGE

EC1B1000

CLEANING

Frequent cleaning of your machine will enhance its appearance, maintain good overall performance, and extend the life of many components.

1. Before washing the machine, block off the end of the exhaust pipe to prevent water from entering. A plastic bag secured with a rubber band may be used for this purpose.
2. If the engine is excessively greasy, apply some degreaser to it with a paint brush. Do not apply degreaser to the chain, sprockets, or wheel axles.
3. Rinse the dirt and degreaser off with a garden hose; use only enough pressure to do the job.

CAUTION:

Excessive hose pressure may cause water seepage and contamination of wheel bearings, front forks, brakes and transmission seals. Many expensive repair bills have resulted from improper high pressure detergent applications such as those available in coin-operated car washers.

4. After the majority of the dirt has been hosed off, wash all surfaces with warm water and a mild detergent. Use an old toothbrush to clean hard-to-reach places.
5. Rinse the machine off immediately with clean water, and dry all surfaces with a soft towel or cloth.
6. Immediately after washing, remove excess water from the chain with a paper towel and lubricate the chain to prevent rust.
7. Clean the seat with a vinyl upholstery cleaner to keep the cover pliable and glossy.
8. Automotive wax may be applied to all painted or chromed surfaces. Avoid combination cleaner-waxes, as they may contain abrasives.
9. After completing the above, start the engine and allow it to idle for several minutes.

EC1B2010

STORAGE

If your machine is to be stored for 60 days or more, some preventive measures must be taken to avoid deterioration. After cleaning the machine thoroughly, prepare it for storage as follows:

1. Drain the fuel tank, fuel lines, and the carburetor float chambers.
2. Remove the spark plugs, pour a tablespoon of SAE 10W30 motor oil in the spark plug hole, and reinstall the plug. With the engine stop switch pushed in, kick the engine over several times to coat the cylinder walls with oil.
3. Remove the drive chain, clean it thoroughly with solvent, and lubricate it. Reinstall the chain or store it in a plastic bag tied to the frame.
4. Lubricate all control cables.
5. Block the frame up to raise the wheels off the ground.
6. Tie a plastic bag over the exhaust pipe outlet to prevent moisture from entering.
7. If the machine is to be stored in a humid or salt-air environment, coat all exposed metal surfaces with a film of light oil. Do not apply oil to rubber parts or the seat cover.
8. Drain the cooling water completely. And then fill the coolant and water (50%:50%) in the engine and radiator.

NOTE: _____

Make any necessary repairs before the machine is stored.



EC200000

SPECIFICATIONS

EC211000

GENERAL SPECIFICATIONS

Model name:	TZ125M1 (USA) TZ125(M) (OTHERS)
Model code number:	4JT7
Dimensions:	
Overall length	1,828 mm (72.0 in)
Overall width	510 mm (20.1 in)
Overall height	1,033 mm (40.7 in)
Seat height	701 mm (27.6 in)
Wheelbase	1,242 mm (48.9 in)
Minimum ground clearance	110 mm (4.3 in)
Basic weight:	
With oil and full fuel tank	82.0 kg (181 lb)
Engine:	
Engine type	Liquid cooled 2-stroke, gasoline
Cylinder arrangement	Single cylinder, forward inclined
Displacement	124 cm ³ (4.36 Imp oz, 4.19 US oz)
Bore×Stroke	54×54.5 mm (2.126×2.146 in)
Compression ratio	7.9 : 1
Starting system	Push to start
Lubrication system:	Premix (30 : 1) (Castrol A747)
Oil type or grade (2-Cycle) :	
Transmission oil	Castrol R30
Periodic oil change	0.30 L (0.26 Imp qt, 0.32 US qt)
Total amount	0.33 L (0.29 Imp qt, 0.35 US qt)
Cooling water capacity (including all routes) :	0.85 L (0.75 Imp qt, 0.90 US qt)
Fuel:	
Type	Except for AUS: Premium unleaded fuel with a research octane number of 95 or higher For AUS: Unleaded fuel only
Tank capacity	13.0 L (2.86 Imp gal, 3.43 US gal)
Carburetor:	
Type/Manufacturer	PWM38/KEIHIN
Spark plug:	
Type/Manufacturer	R6385-105P/NGK
Gap	0.5~0.6 mm (0.020~0.024 in)
Clutch type:	Dry, multiple-disc



<p>Transmission:</p> <p>primary reduction system</p> <p>Primary reduction ratio</p> <p>Secondary reduction system</p> <p>Secondary reduction ratio</p> <p>Transmission type</p> <p>Operation</p> <p>Gear ratio: 1st</p> <p> 2nd</p> <p> 3rd</p> <p> 4th</p> <p> 5th</p> <p> 6th</p>	<p>Spur gear</p> <p>60/21 (2.857)</p> <p>Chain drive</p> <p>36/17 (2.118)</p> <p>Constant mesh, 6-speed</p> <p>Left foot operation</p> <p>30/15 (2.000)</p> <p>31/19 (1.632)</p> <p>24/17 (1.412)</p> <p>25/20 (1.250)</p> <p>24/21 (1.143)</p> <p>26/24 (1.083)</p>
<p>Chassis:</p> <p>Frame type</p> <p>Caster angle</p> <p>Trail</p>	<p>Delta box</p> <p>22.6°</p> <p>85.5 mm (3.37 in)</p>
<p>Tire:</p> <p>Type</p> <p>Size (front)</p> <p>Size (rear)</p> <p>Tire pressure (front and rear)</p>	<p>Tubeless</p> <p>95/70 R17</p> <p>125/55 R17</p> <p>180 kPa (1.8 kg/cm², 26 psi)</p>
<p>Brake:</p> <p>Front brake type</p> <p>Operation</p> <p>Rear brake type</p> <p>Operation</p>	<p>Single disc brake</p> <p>Right hand operation</p> <p>Single disc brake</p> <p>Right foot operation</p>
<p>Suspension:</p> <p>Front suspension</p> <p>Rear suspension</p>	<p>Telescopic fork</p> <p>Swingarm (link type monocross suspension)</p>
<p>Shock absorber:</p> <p>Front shock absorber</p> <p>Rear shock absorber</p>	<p>Coil spring/oil damper</p> <p>Coil spring/gas, oil damper</p>
<p>Wheel travel:</p> <p>Front wheel travel</p> <p>Rear wheel travel</p>	<p>100 mm (3.94 in)</p> <p>129 mm (5.08 in)</p>
<p>Electrical:</p> <p>Ignition system</p>	<p>CDI magneto</p>



EC212000

MAINTENANCE SPECIFICATIONS

EC212100

ENGINE

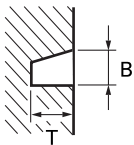
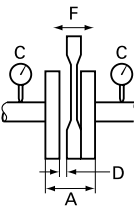
Item	Standard	Limit
Cylinder head: Combustion chamber capacity	9.05 cm ³ (0.319 Imp oz, 0.306 US oz)	...
Piston: Piston clearance	0.075~0.085 mm (0.0030~0.0033 in)	...
Piston offset	1.0 mm (0.039 in)/EX-side	...
Piston pin: Piston pin outside diameter	14.995~15.000 mm (0.5904~0.5906 in)	14.975 mm (0.5896 in)
Piston ring: Sectional sketch  End gap (installed) Side clearance (installed)	Keystone B=1.0 mm (0.039 in) T=2.2 mm (0.087 in) 0.22~0.37 mm (0.009~0.015 in) 0.02~0.06 mm (0.0008~0.0024 in) 0.59 mm (0.023 in) 0.1 mm (0.004 in)
Crankshaft: Crank width "A" Runout limit "C" Connecting rod big end side clearance "D" Small end free play "F" 	52.90~52.95 mm (2.083~2.085 in) 0.03 mm (0.0012 in) 0.2~0.7 mm (0.008~0.028 in) 0.8~1.0 mm (0.031~0.039 in)	... 0.05 mm (0.0020 in) ... 2.0 mm (0.08 in)
Clutch: Friction plate thickness Quantity Clutch plate thickness Quantity Warp limit Clutch spring free length Quantity Clutch housing thrust clearance Clutch housing radial clearance Clutch release method Push rod bending limit	2.9~3.1 mm (0.114~0.122 in) 6 1.4~1.8 mm (0.055~0.071 in) 5 ... 36.0 mm (1.417 in) 5 0.07~0.18 mm (0.003~0.007 in) 0.009~0.071 mm(0.0004~0.0028 in) Inner push, cam push ...	2.7 mm (0.106 in) 0.1 mm (0.004 in) 35.0 mm (1.378 in) 0.2mm (0.008 in)
Transmission: Main axle deflection limit Drive axle deflection limit	0.01 mm (0.0004 in) 0.01 mm (0.0004 in)
Shifter: Shifting type Guide bar bending limit	Cam drum and guide bar 0.04 mm (0.0016 in)

MAINTENANCE SPECIFICATIONS

SPEC



Item	Standard	Limit
Carburetor:		
Type/Manufacturer	PWM38/KEIHIN	...
I.D. mark	4JT7 60	...
Main jet (M.J.)	#220	...
Jet needle-clip position (J.N.)	N8VH-3	...
Main nozzle (N.J.)	ø2.9	...
Cutaway (C.A.)	#7	...
Pilot jet (P.J.)	#42	...
Pilot air screw (P.A.S.)	Factory set	...
Valve seat size (V.S.)	ø3.8	...
Starter jet (G.S.)	#85	...
Power jet (P.W.J.)	#60	...
Float arm height (F.H.)	5.5~7.5 mm (0.22~0.30 in)	...
Reed valve:		
Thickness* reed valve 1	0.42 mm (0.017 in)	...
reed valve 2	0.34 mm (0.013 in)	...
Valve stopper height	10.6~11.0 mm (0.417~0.433 in)	...
Valve bending limit	...	0.2 mm (0.008 in)
Cooling:		
Radiator core size:		
Width	300 mm (11.81 in)	...
Height	198 mm (7.80 in)	...
Thickness	24 mm (0.94 in)	...
Radiator cap opening pressure	95~125 kPa (0.95~1.25 kg/cm ² , 13.5~17.8 psi)	...
Radiator capacity	0.53 L (0.471 Imp qt, 0.56 US qt)	...
Water pump:		
Type	Single-suction centrifugal pump	...

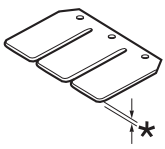

MAINTENANCE SPECIFICATIONS

SPEC



Part to be tightened	Thread size	Q'ty	Tightening torque		
			Nm	m•kg	ft•lb
Spark plug	M14S × 1.25	1	19	1.9	13
Cylinder head (bolt)	M 6 × 1.0	6	11	1.1	8.0
Cylinder (nut)	M 8 × 1.25	4	20	2.0	14
(stud)	M 8 × 1.25	4	15	1.5	11
Balance weight gear	M14 × 1.0	1	50	5.0	36
Water pump housing cover	M 6 × 1.0	3	11	1.1	8.0
Radiator	M 6 × 1.0	3	7	0.7	5.1
Radiator and thermo unit	M16 × 1.5	1	11	1.1	8.0
Radiator hose clamp	–	6	2	0.2	1.4
Oil pump cover	M 5 × 0.8	1	4	0.4	2.9
Oil pump assembly	M 6 × 1.0	2	7	0.7	5.1
Carburetor joint	M 6 × 1.0	6	11	1.1	8.0
Clamp (carburetor joint)	M 4 × 0.7	1	2	0.2	1.4
Reed valve	M 3 × 0.5	6	1	0.1	0.7
Exhaust pipe	M 8 × 1.25	1	21	2.1	15
Silencer	M 6 × 1.0	2	11	1.1	8.0
Crankcase	M 6 × 1.0	13	11	1.1	8.0
Transmission housing	M 6 × 1.0	7	14	1.4	10
Holder (crankshaft oil seal)	M 8 × 1.25	1	16	1.6	11
Blind plug	M 8 × 1.25	1	11	1.1	8.0
Oil drain bolt	M12 × 1.5	1	23	2.3	17
Oil check bolt	M 6 × 1.0	1	9	0.9	6.5
Crankcase cover (left)	M 6 × 1.0	3	11	1.1	8.0
Crankcase cover (right)	M 6 × 1.0	10	11	1.1	8.0
Primary drive gear	M10 × 1.25	1	55	5.5	40
Clutch boss	M14 × 1.0	1	50	5.0	36
Clutch spring	M 5 × 0.8	5	6	0.6	4.3
Adjuster (push rod 1) and locknut	M 6 × 1.0	1	6	0.6	4.3
Seat plate (push lever)	M 6 × 1.0	1	11	1.1	8.0
Bearing plate cover	M 6 × 1.0	6	8	0.8	5.8
Bearing plate cover (shift cam)	M 5 × 0.8	2	8	0.8	5.8
Drive sprocket	M16 × 1.0	1	60	6.0	43
Stopper Lever	M 6 × 1.0	1	11	1.1	8.0
Shift arm	M 6 × 1.0	1	14	1.4	10
Shift pedal	M 8 × 1.25	1	22	2.2	16
Joint rod 1 and shift rod	M 6 × 1.0	1	9	0.9	6.5
Joint rod 2 and shift rod	M 6 × 1.0	1	9	0.9	6.5
Joint rod 1, 2	M 6 × 1.0	2	11	1.1	8.0



EC212201

CHASSIS

Item	Standard	Limit
Steering system: Steering bearing type	Taper roller bearing	...
Front suspension: Front fork travel Fork spring free length Spring rate, STD Optional spring Oil capacity Oil level <Min.-Max.> (From top of outer tube with inner tube and damper rod fully compressed without spring.) Oil grade Inner tube outer diameter Front fork top end	100 mm (3.94 in) 195 mm (7.68 in) K=6.00 N/mm (0.600 kg/mm, 33.7 lb/in) No 282 cm ³ (9.9 Imp oz, 9.5 US oz) 110 mm (4.33 in) 80~140 mm (3.15~5.51 in) Suspension oil "01" 36 mm (1.42 in) 18 mm (0.71 in)	... 193 mm (7.60 in)
Rear suspension: Shock absorber travel Spring free length Fitting length <Min.-Max.> Spring rate, STD Optional spring Enclosed gas pressure	58 mm (2.28 in) 150 mm (5.91 in) 138 mm (5.43 in) 130~150 mm (5.12~5.91 in) K=72 N/mm (7.2 kg/mm, 403 lb/in) No 1,200 kPa (12 kg/cm ³ , 171 psi)
Swingarm: Swingarm free play limit End Side clearance	1.0 mm (0.04 in) 0.05~0.35 mm (0.002~0.014 in)
Wheel: Front wheel type Rear wheel type Front rim size/Material Rear rim size/Material Wheel runout limit: Radial Lateral	Cast wheel Cast wheel MT 2.50×17/Aluminum MT 3.50×17/Aluminum 1.0 mm (0.04 in) 0.5 mm (0.02 in)
Drive chain Type/Manufacturer Number of links Chain slack Chain length (10 links)	RK415HRU/RK EXCEL 119 links + joint 30~40 mm (1.2~1.6 in) 120.0 mm (4.724 in)

MAINTENANCE SPECIFICATIONS

SPEC



Item	Standard	Limit
Front disc brake: Disc outside dia. × Thickness Pad thickness Master cylinder inside dia. Caliper cylinder inside dia. Brake fluid type	298×5.0 mm (11.73×0.20 in) 5.3 mm (0.21 in) 14.0 mm (0.551 in) 33.96 + 30.23 mm (1.337 + 1.190 in) DOT #4	... 1.0 mm (0.04 in)
Rear disc brake: Disc outside dia. × Thickness Deflection limit Pad thickness Master cylinder inside dia. Caliper cylinder inside dia. Brake fluid type	185×4.0 mm (7.28×0.16 in) ... 4.0 mm (0.16 in) 12.7 mm (0.500 in) 25.4 mm (1.000 in) DOT #4	... 0.15 mm (0.006 in) 1.0 mm (0.04 in)
Brake lever & brake pedal: Brake pedal position Clutch lever free play (at lever pivot) Throttle grip free play	148~152 mm (5.8~6.0 in) 2~3 mm (0.08~0.12 in) 2~4 mm (0.08~0.16 in)

MAINTENANCE SPECIFICATIONS

SPEC



	Part to be tightened	Thread size	Q'ty	Tightening torque		
				Nm	m•kg	ft•lb
Δ	Handle crown and outer tube	M 8 × 1.25	2	15	1.5	11
Δ	Under bracket and outer tube	M10 × 1.25	2	20	2.0	14
Δ	Handle crown and steering shaft	M22 × 1.0	1	80	8.0	58
Δ	Handle bracket and outer tube	M 6 × 1.0	4	8	0.8	5.8
Δ	Handlebar and handle bracket	M 6 × 1.0	2	8	0.8	5.8
Δ	Steering ring nut	M25 × 1.0	1	Refer to NOTE		
	Steering damper and frame	M 8 × 1.25	1	18	1.8	13
	Steering damper and damper bracket	M 6 × 1.0	1	5	0.5	3.6
	Steering damper stay and outer tube	M 6 × 1.0	1	7	0.7	5.1
	Clutch lever holder	M 5 × 0.8	2	5	0.5	3.6
Δ	Front master cylinder and master cylinder bracket	M 6 × 1.0	2	8	0.8	5.8
	Brake lever (bolt)	M 6 × 1.0	1	1	0.1	0.7
	Brake lever (nut)	M 6 × 1.0	1	6	0.6	4.3
	Front fork and cap bolt	M40 × 1.0	2	23	2.3	17
	Front fork and damper rod	M12 × 1.25	2	40	4.0	29
	Cap bolt and damper rod	M10 × 1.0	2	15	1.5	11
	Front fork and front fender	M 6 × 1.0	4	8	0.8	5.8
Δ	Front wheel axle and nut	M14 × 1.5	1	48	4.8	35
Δ	Front wheel axle holder	M 8 × 1.25	2	20	2.0	14
Δ	Front brake disc and wheel hub	M 8 × 1.25	6	23	2.3	17
Δ	Rear Brake disc and wheel hub	M 8 × 1.25	3	23	2.3	17
Δ	Brake hose (front and rear) and union bolt (master cylinder)	M10 × 1.25	2	30	3.0	22
Δ	Brake hose (front and rear) and adapter	M10 × 1.25	2	14	1.4	10
Δ	Brake caliper (front and rear) and adapter	M10 × 1.25	2	26	2.6	19
Δ	Front brake caliper and front fork	M10 × 1.25	2	35	3.5	25
Δ	Brake caliper (front and rear) and pad pin	M10 × 1.25	2	18	1.8	13
Δ	Brake caliper (front and rear) and bleed screw	M 8 × 1.25	3	6	0.6	4.3
	Front brake reservoir tank and handle crown	M 6 × 1.0	1	5	0.5	3.6
	Footrest bracket and frame	M 8 × 1.25	4	20	2.0	14
	Footrest and footrest bracket	M 6 × 1.0	2	12	1.2	8.7
Δ	Brake pedal and rear master cylinder	M 6 × 1.0	1	12	1.2	8.7
Δ	Rear master cylinder and footrest bracket	M 8 × 1.25	2	20	2.0	14
	Rear master cylinder and reservoir connector	M 4 × 0.7	1	2	0.2	1.4
	Rear brake reservoir tank and frame	M 6 × 1.0	1	3	0.3	2.2
Δ	Rear brake caliper and caliper bracket	M 8 × 1.25	2	23	2.3	17
Δ	Rear wheel axle and nut	M18 × 1.5	1	63	6.3	45
Δ	Driven sprocket and sprocket damper	M 8 × 1.25	4	32	3.2	23
	Chain puller adjust bolt and locknut	M 8 × 1.25	2	16	1.6	11
	Chain puller adjust bolt	M 8 × 1.25	2	2	0.2	1.4

NOTE:

1. First, tighten the ring nut approximately 46 Nm (4.6 m•kg, 33 ft•lb) by using the ring nut wrench, then loosen the ring nut one turn.
2. Retighten the ring nut 1 Nm (0.1 m•kg, 0.7 ft•lb).



	Part to be tightened	Thread size	Q'ty	Tightening torque		
				Nm	m•kg	ft•lb
Δ	Engine mounting :					
Δ	Engine and frame (front)	M10 × 1.25	1	30	3.0	22
Δ	Engine and frame (upper)	M10 × 1.25	1	30	3.0	22
Δ	Engine and frame (lower)	M10 × 1.25	1	30	3.0	22
Δ	Pinch bolt (engine mounting bolt)	M 6 × 1.0	2	11	1.1	8.0
Δ	Engine mounting adjust bolt	M16 × 1.0	2	8	0.8	5.8
Δ	Pivot shaft and nut	M16 × 1.5	1	63	6.3	45
Δ	Pivot adjust bolt	M22 × 1.0	1	5	0.5	3.6
Δ	Relay arm and frame	M10 × 1.25	1	34	3.4	24
Δ	Relay arm and connecting rod	M10 × 1.25	1	34	3.4	24
Δ	Connecting rod and swingarm	M10 × 1.25	1	34	3.4	24
Δ	Rear shock absorber and upper bracket	M10 × 1.25	1	34	3.4	24
Δ	Rear shock absorber and relay arm	M10 × 1.25	1	34	3.4	24
	Rear shock absorber and locknut (preload)	M46 × 1.5	1	40	4.0	29
Δ	Seat height adjuster and locknut	M22 × 1.0	1	38	3.8	27
Δ	Seat height adjuster and upper bracket	M10 × 1.25	1	40	4.0	29
	Swingarm and seal guard	M 5 × 0.8	4	2	0.2	1.4
	Swingarm and brake hose holder	M 6 × 1.0	2	8	0.8	5.8
	Swingarm and hook	M 6 × 1.0	2	10	1.0	7.2
	Swingarm and chain guide	M 6 × 1.0	2	8	0.8	5.8
	Cowling stay bracket and frame	M 6 × 1.0	2	8	0.8	5.8
	Cowling stay and cowling stay bracket	M 6 × 1.0	2	8	0.8	5.8
	Cowling stay (left and right) and frame	M 6 × 1.0	2	8	0.8	5.8
	Upper cowl and screen	M 4 × 0.7	7	4	0.4	2.9
Δ	Fuel tank and fuel cock	M 6 × 1.0	2	7	0.7	5.1
	Rear frame and seat	M 6 × 1.0	4	8	0.8	5.8
Δ	Rear frame and frame	M 8 × 1.25	4	23	2.3	17
	Radiator stay and frame	M 6 × 1.0	1	8	0.8	5.8

NOTE:

Δ - marked portion shall be checked for torque tightening after break-in or before each race.



EC212300

ELECTRICAL

Item	Standard	Limit
Ignition system: Ignition timing (B.T.D.C) Advancer type	2.3 mm (0.091 in) Electrical
CDI: Magneto-model/Manufacturer Source coil resistance (color) Pickup coil resistance (color) CDI unit-model/Manufacturer	4JT-00/DENSO 1.3~1.9 Ω at 20°C (68°F) (White-White) 94~140 Ω at 20°C (68°F) (White/Black-White/Green) 4JT-60/DENSO
Ignition coil: Model/Manufacturer Minimum spark gap Primary winding resistance Secondary winding resistance	TJ0294/DENSO 5 mm (0.20 in) 0.14~0.18 Ω at 20°C (68°F) 5.0~7.4 kΩ at 20°C (68°F)

Part to be tightened	Thread size	Q'ty	Tightening torque		
			Nm	m•kg	ft•lb
Stator	M 6 × 1.0	2	7	0.7	5.1
Rotor	M12 × 1.25	1	53	5.3	38
Pickup coil	M 4 × 0.7	2	2	0.2	1.4
CDI unit	M 6 × 1.0	2	8	0.8	5.8
Ignition coil	M 6 × 1.0	2	8	0.8	5.8
Voltage regulator	M 6 × 1.0	2	7	0.7	5.1



EC220001

GENERAL TORQUE SPECIFICATIONS

This chart specifies torque for standard fasteners with standard I.S.O. pitch threads. Torque specifications for special components or assemblies are included in the applicable sections of this book. To avoid warpage, tighten multi-fastener assemblies in a crisscross fashion, in progressive stages, until full torque is reached. Unless otherwise specified, torque specifications call for clean, dry threads. Components should be at room temperature.

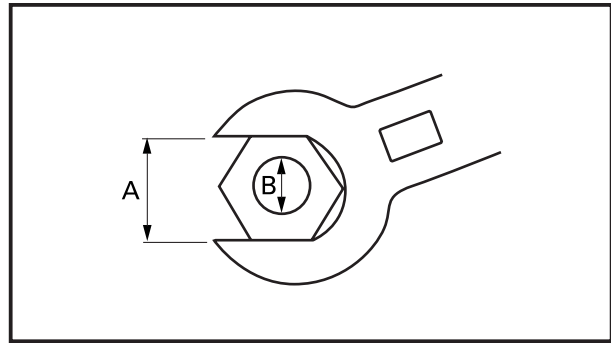

A: Distance across flats

B: Outside thread diameter

A (Nut)	B (Bolt)	TORQUE SPECIFICATION		
		Nm	m•kg	ft•lb
10 mm	6 mm	6	0.6	4.3
12 mm	8 mm	15	1.5	11
14 mm	10 mm	30	3.0	22
17 mm	12 mm	55	5.5	40
19 mm	14 mm	85	8.5	61
22 mm	16 mm	130	13	94

EC230000

DEFINITION OF UNITS

Unit	Read	Definition	Measure
mm	millimeter	10^{-3} meter	Length
cm	centimeter	10^{-2} meter	Length
kg	kilogram	10^3 gram	Weight
N	Newton	$1 \text{ kg} \times \text{m}/\text{sec}^2$	Force
Nm	Newton meter	$\text{N} \times \text{m}$	Torque
m•kg	Meter kilogram	$\text{m} \times \text{kg}$	Torque
Pa	Pascal	N/m^2	Pressure
N/mm	Newton per millimeter	N/mm	Spring rate
L	Liter	–	Volume or capacity
cm ³	Cubic centimeter	–	Volume or capacity
r/min	Revolution per minute	–	Engine speed



EC240000

CABLE ROUTING DIAGRAM

- ① Clamp
 - ② Throttle cable
 - ③ Wireharness
 - ④ Clutch cable
 - ⑤ Front brake hose
 - ⑥ Cable
 - ⑦ Frame
- Ⓐ Do not cut the end of the clamp.
 - Ⓑ Install the clamp with its ends facing backward.
 - Ⓒ Install the clamp with its ends facing upward.
 - Ⓓ Clamp only the wireharness with the clamp ends downward.
 - (Do not clamp the high tension cord.)
 - Ⓔ Cut the clamp so that the protruding portion is less than 5 mm (0.20 in).

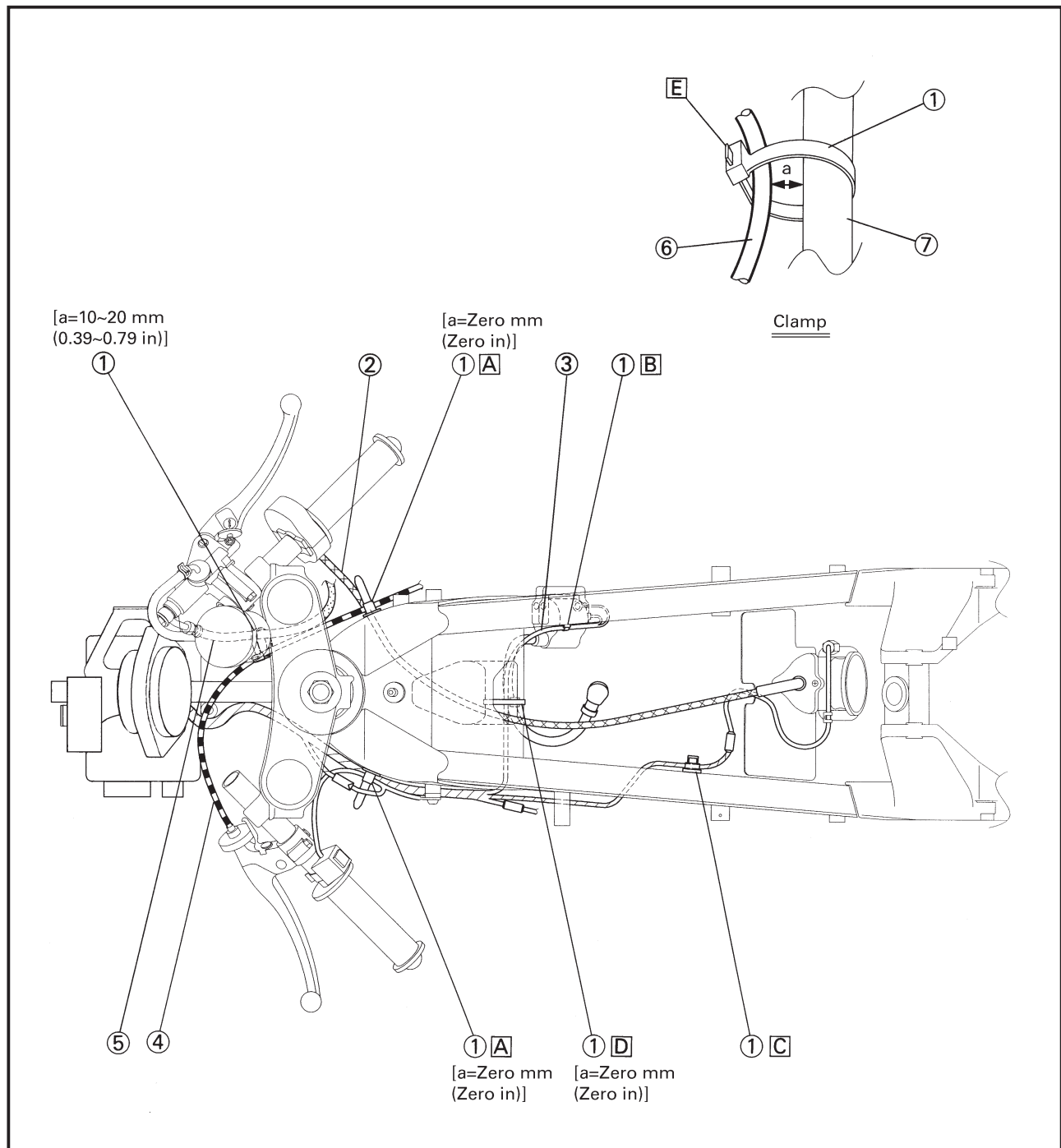

CABLE ROUTING DIAGRAM

SPEC



- ① Tachometer assembly
- ② Clamp
- ③ CDI unit
- ④ Water temperature gauge lead
- ⑤ Wireharness
- ⑥ "ENGINE STOP" button
- ⑦ CDI magneto lead

- A Install the tachometer assembly with its figures standing upright.
- B Align the tape on the wireharness with the CDI unit mounting boss.
- C Install the CDI magneto lead so that it is not loose.
- D Clamp the coupler with the clamp ends facing backward on the inside of the chassis.
- E Clamp the wireharness at the center of the tape on it.

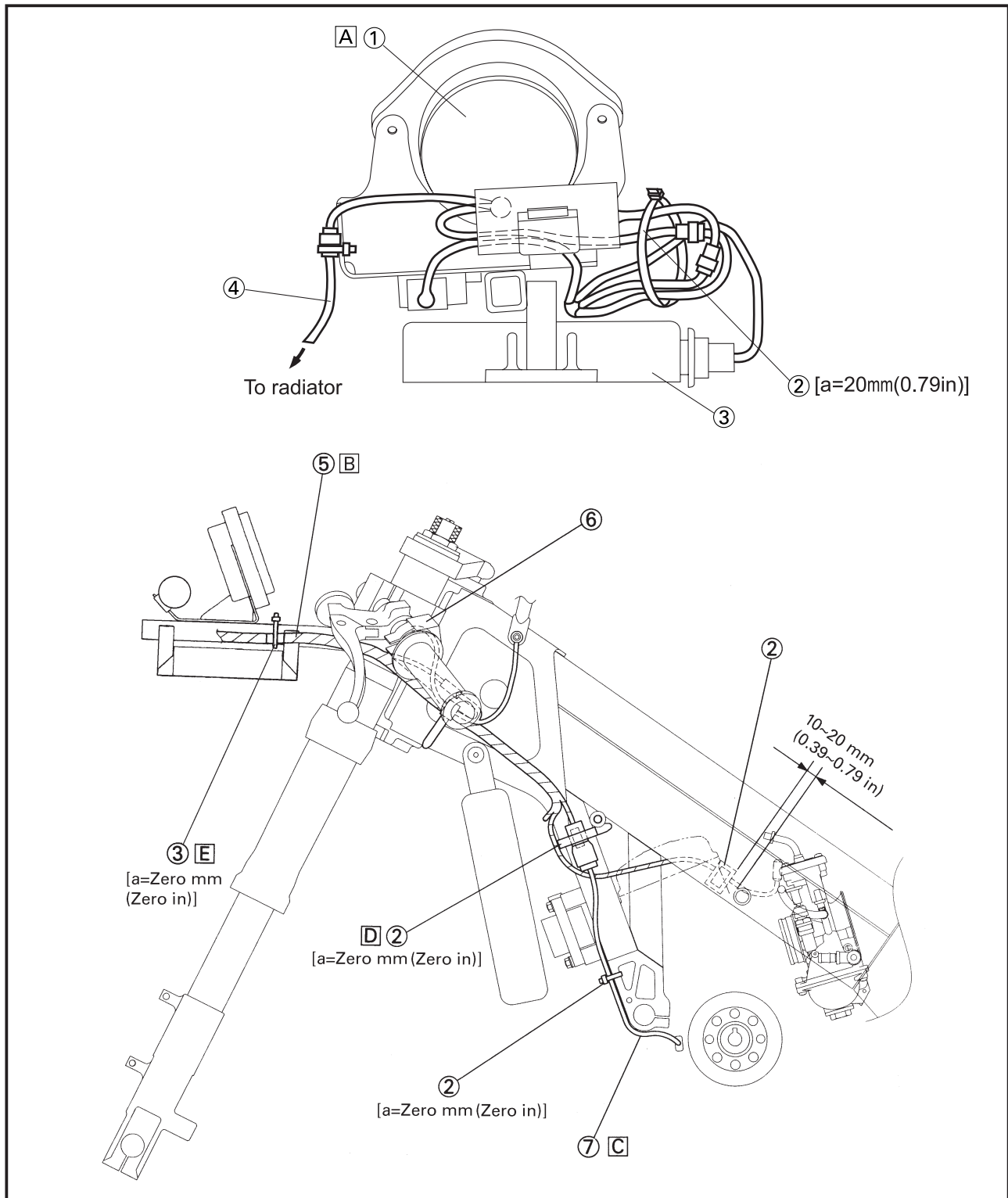

CABLE ROUTING DIAGRAM

SPEC



- ① Throttle cable
- ② Clamp
- ③ Front brake hose
- ④ Clutch cable

- A Clamp the water temperature lead at its coupler portion.
- B Position the end of the clamp to the front of the front fork.
- C Be sure the brake hose is not twisted.
- D Do not tighten the clamp too much.
- E Clamp the clutch cable at its adjusting portion.
- F Install the clamp with its ends facing backward.

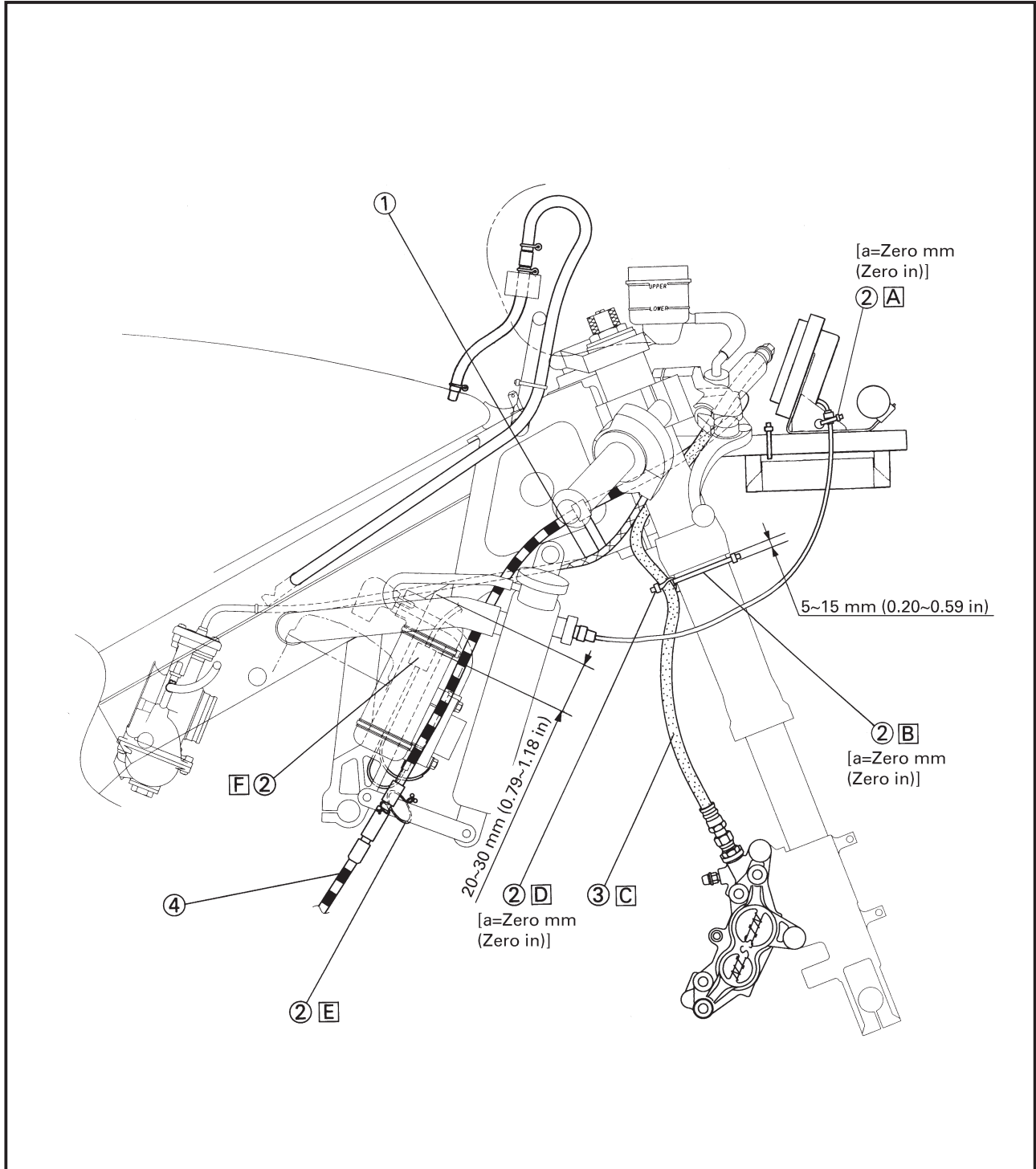

CABLE ROUTING DIAGRAM

SPEC



- ① Brake hose holder
- ② Reservoir hose
- ③ Rear brake hose
- ④ Clamp

- Ⓐ Position the reservoir hose with the paint facing upward.
- Ⓑ Be sure the brake hose is not twisted.
- Ⓒ Clamp the brake hose with the end of the clamp forward. Do not cut the end of the clamp.

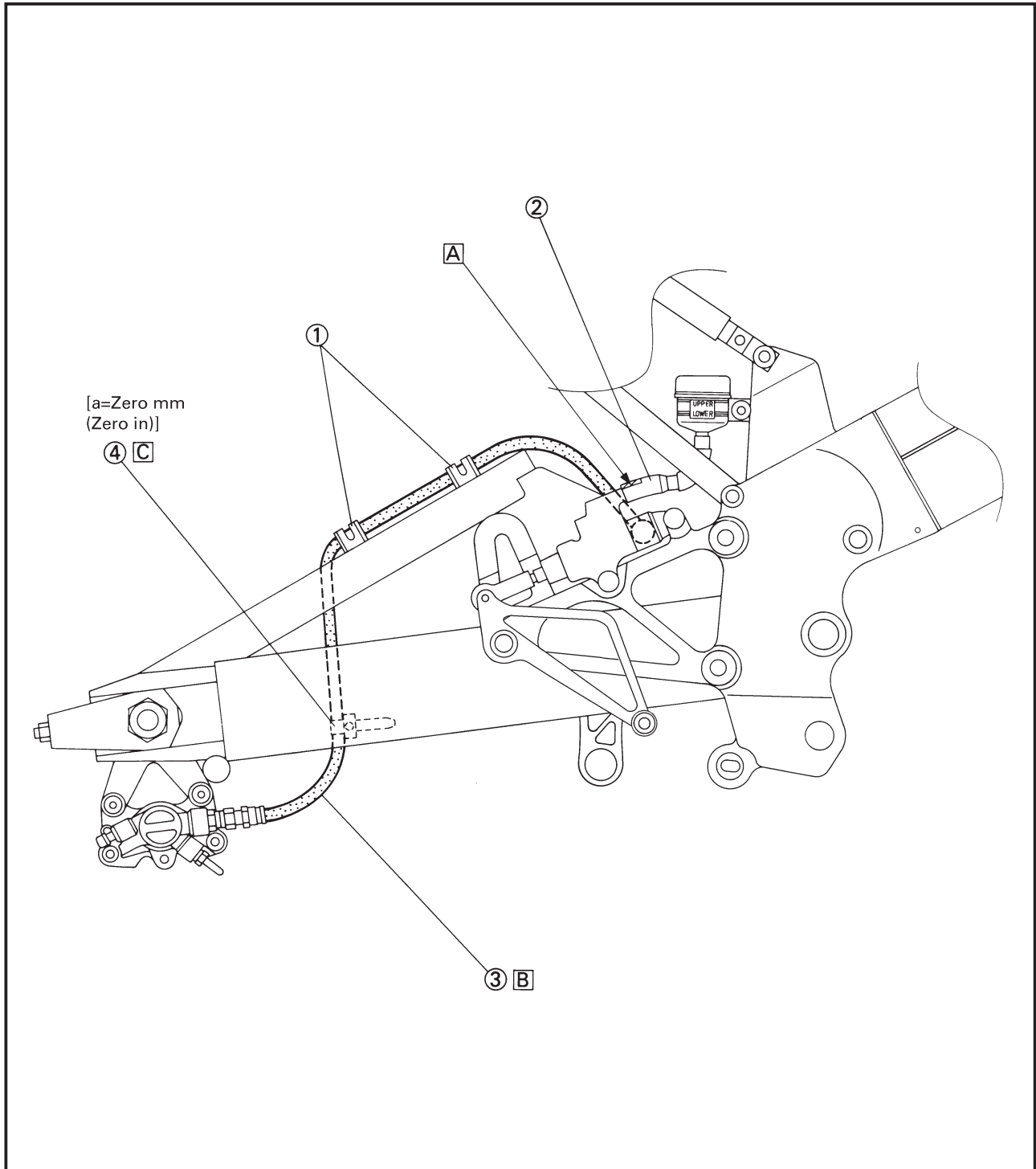

EC300000

REGULAR INSPECTION AND ADJUSTMENTS

EC310062

MAINTENANCE INTERVALS

The following schedule is intended as a general guide to maintenance and lubrication. Bear in mind that such factors as weather, terrain, geographical location, and individual usage will alter the required maintenance and lubrication intervals. If you are a doubt as to what intervals to follow in maintaining and lubricating your machine, consult your Yamaha dealer.

NOTE:

Replace earlier depending on the operating condition.

Item	After break-in	Every race	Every 500km	Every 1,000 km	As required	Remarks
PISTON Inspect and clean Replace	●	●	●		●	Inspect crack
PISTON PIN, SMALL END BEARING Inspect Replace	●	●	●		●	
PISTON RING Inspect Replace	●	●	●		●	Check ring end gap
CYLINDER HEAD Inspect and clean Retighten	● ●	● ●				Remove carbon Check O-ring
CYLINDER Inspect and clean Replace Retighten	● ●	● ●		(3,000 km) ●	●	Inspect score marks Inspect wear
CLUTCH Inspect and adjust Replace	●	●			●	Inspect housing, friction plate, clutch plate and spring
TRANSMISSION Replace oil Inspect transmission Replace bearing	●		●		● ●	Castrol R30
SHIFT FORK, SHIFT CAM, GUIDE BAR Inspect					●	Inspect wear
ROTOR NUT Retighten				●		
MUFFLER Inspect Clean	●	●			●	Inspect crack
CRANK Inspect and replace				(1,500 km) ●	●	
CARBURETOR Inspect, adjust and clean Replace	●	●			●	Inspect jet needle clip groove
SPARK PLUG Inspect and clean Replace	●	●			●	

3

MAINTENANCE INTERVALS

INSP
ADJ



Item	After break-in	Every race	Every 500km	Every 1,000 km	As required	Remarks
PLUG CAP Inspect and replace				(1,500 km) ●	●	
COOLING SYSTEM Check cooling level and leakage Check radiator cap operation Replace cooling water Replace hoses	●	●			● ● ●	Use soft water
OUTSIDE NUTS AND BOLTS Retighten	●	●				Refer to "STARTING AND BREAK-IN" section in the CHAPTER 1.
OIL PUMP STRAINER Clean	●		●			
REED VALVE Inspect Replace	●	●			●	
FRAME Clean and inspect	●	●				
FUEL TANK, COCK Clean and inspect	●	●				
BRAKES Adjust lever position and pedal position Check brake disc surface Check brake fluid level and leakage Retighten brake disc bolts, caliper bolts and master cylinder bolts Replace pads Replace brake fluid	● ● ● ●	● ● ●			● ●	Every one year
FRONT FORKS Inspect and adjust Replace oil Replace oil seal	●	●		●	●	Suspension oil "01"
REAR SHOCK ABSORBER Inspect and adjust Lube Retighten	● ●	● ●			(After rain race) ●	Lithium base grease
CHAIN GUARD Replace					●	
SWINGARM Inspect and retighten	●	●				
RELAY ARM, CONNECTING ROD Inspect and retighten	●	●				
STEERING HEAD Inspect free play and retighten Clean and lube Replace bearings	●	●		●	●	Lithium base grease
TIRE, WHEELS Inspect air pressure, wheel run-out and tire wear Inspect bearings Replace bearings Lubricate	● ●	● ●		●	●	Lithium base grease

MAINTENANCE INTERVALS



Item	After break-in	Every race	Every 500km	Every 1,000 km	As required	Remarks
DRIVE CHAIN Lubricate, slack, alignment Replace	●	●		●		Use chain lube Chain slack: 30~40 mm (1.2~1.6 in)
DRIVE, DRIVEN SPROCKET Inspect and replace					●	Inspect wear
DRIVEN SPROCKET DAMPER Inspect and retighten Replace	●		●		●	
THROTTLE, CONTROL CABLE Check routing and connection Lubricate	● ●	● ●				Yamaha cable lube or SAE 10W30 motor oil

EC320010

PRE-OPERATION INSPECTION AND MAINTENANCE

Before riding for break-in operation, practice or a race, make sure the machine is in good operating condition.

Before using this machine, check the following points.

NOTE:

- The brake disc is coated with a rust inhibitor. Before pre-operation thoroughly remove it using a lacquer thinner.
- For storage, a coolant is used. Before riding the machine remove it with cooling water. Refer to "INFORMATION BEFORE PRE-OPERATION".

EC321010

GENERAL INSPECTION AND MAINTENANCE

Item	Routine	Page
Cooling water	Check that cooling water is filled up to the radiator filler cap. Check the cooling system for leakage.	P3-6~9
Fuel	Check that a fresh mixture of oil and gasoline is filled in the fuel tank. Check the fuel line for leakage.	P1-14
Transmission oil	Check that the oil level is correct. Check the crankcase for leakage.	P3-10~11
Gear shifter and clutch	Check that gears can be shifted correctly in order and that the clutch operates smoothly.	P3-9
Throttle grip/Housing	Check that the throttle grip operation and free play are correctly adjusted. Lubricate the throttle grip and housing, if necessary.	P3-9~10
Brakes	Check the effect of front and rear brake. Check brake disc surface.	P3-13~18
Chain	Check chain slack and alignment. Check that the chain is lubricated properly.	P3-19~21
Wheels	Check for excessive wear, tire pressure and tire wear.	P3-32~33
Steering	Check that the handlebars can be turned smoothly and have no excessive play.	P3-33~34
Front forks and rear shock absorber	Check that they operate smoothly and there is no oil leakage.	P3-23~32
Cables (wires)	Check that the clutch and throttle cables move smoothly. Check that they are not caught when the handlebars are turned or when the front forks travel up and down.	P3-35
Muffler	Check that the muffler is tightly mounted and has no cracks.	P3-12
Sprocket	Check that the driven sprocket damper is not loose.	P3-18
Lubrication	Check for smooth operation. Lubricate if necessary.	P3-36
Bolts and nuts	Check the chassis and engine for loose bolts and nuts. Check that the locking wire is correct.	P1-19
Lead connectors	Check that the CDI magneto, CDI unit, and ignition coil are connected tightly.	P1-5
Cowling	Check that the cowling is tightly mounted and has no cracks in it. Check that it does not contact other parts by stroking. Check that the screen is clean.	P3-35
Settings	Is the machine set suitably for the condition of the racing course and weather or by taking into account the results of test runs before racing? Are inspection and maintenance completely done?	P7-1~22



EC340000

LOCKING WIRE INSTALLATION GUIDE

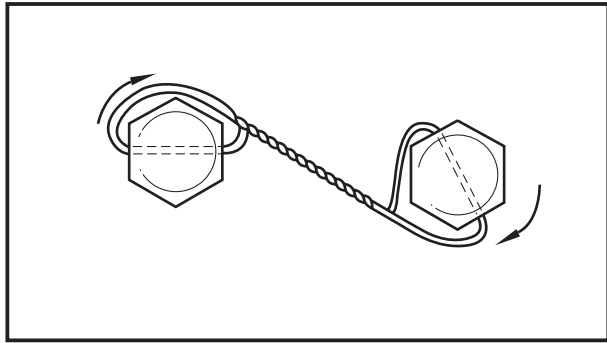

Bolt to bolt

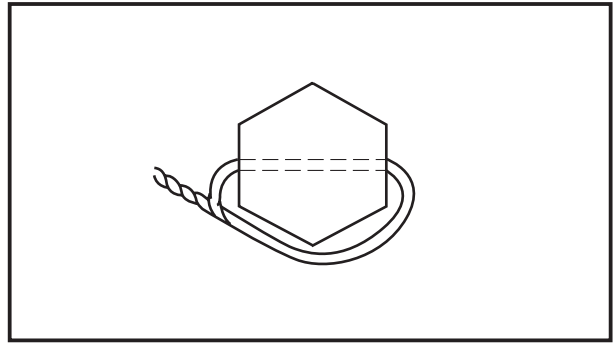

Bolt

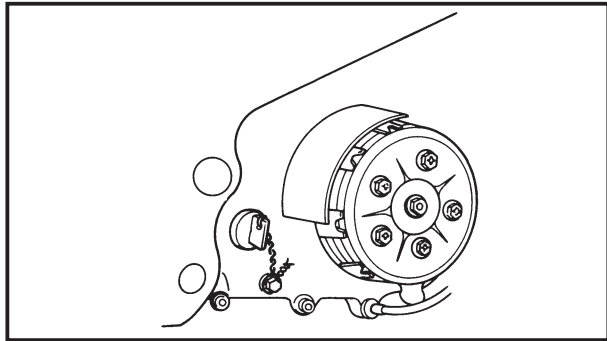

Oil filler cap and check bolt

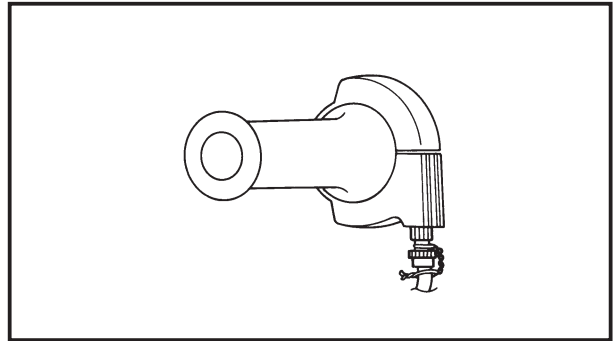

Throttle cable adjuster

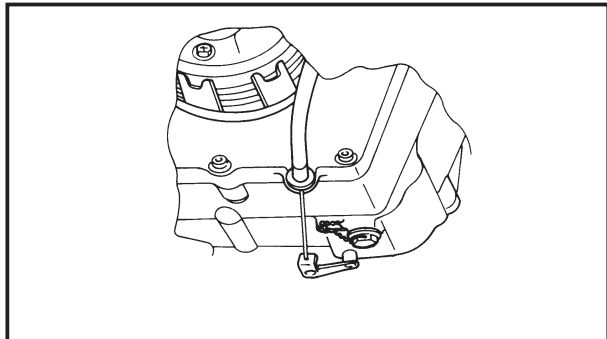

Oil drain bolt

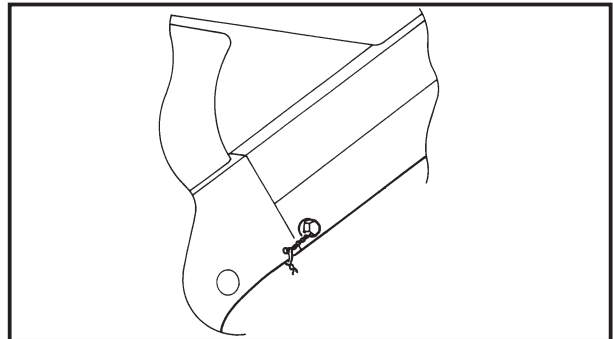

Tank rail drain bolt



EC350011

ENGINE

CAUTION:

- The cooling system is filled with coolant at the factory to prevent rusting. Be sure to replace coolant with soft water before riding.
- Take care so that coolant does not splash on painted surfaces. If it splashes, wash it away with water.

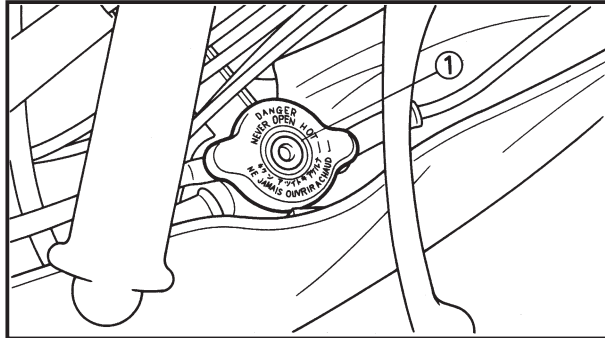

EC352000

COOLING WATER LEVEL INSPECTION

WARNING

Do not remove the radiator cap ①, drain bolt and hoses when the engine and radiator are hot. Scalding hot fluid and steam may be blown out under pressure, which could cause serious injury.

When the engine has cooled, place a thick towel over the radiator cap, slowly rotate the cap counterclockwise to the detent. This procedure allows any residual pressure to escape. When the hissing sound has stopped, press down on the cap while turning counterclockwise and remove it.

CAUTION:

Hard water or salt water is harmful to the engine parts. You may use distilled water, if you can't get soft water.

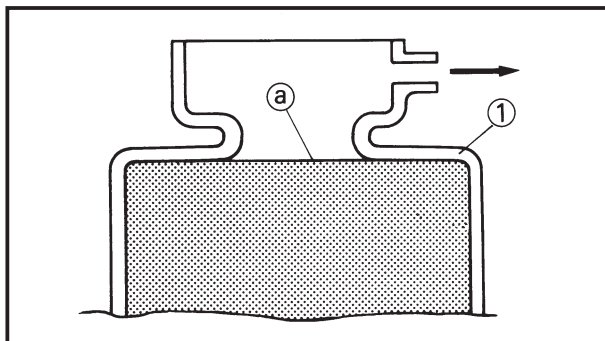

1. Place the machine on a level place, and hold it in an upright position.
 2. Remove:
 - Radiator cap
 3. Check:
 - Cooling water level (a)
Cooling water level low -> Add cooling water.
- ① Radiator

EC354002

COOLING WATER REPLACEMENT

WARNING

Do not remove the radiator cap when the engine is hot.

1. Remove the lower cowl.
2. Place a container under the radiator hose.

RADIATOR CAP INSPECTION

INSP
ADJ

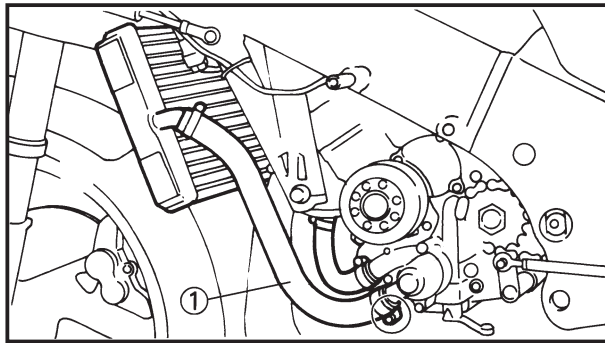

3. Disconnect:
 - Radiator hose 2 ①
4. Remove:
 - Radiator capDrain the cooling water completely.
5. Clean:
 - Cooling systemThoroughly flush the cooling system with clean tap water.
6. Connect:
 - Radiator hose 2

 2 Nm (0.2 m•kg, 1.4 ft•lb)

7. Fill:
 - Radiator
 - EngineTo specified level.



Recommended cooling water:

Soft water

Cooling water capacity:

0.85 L (0.75 Imp qt, 0.90 US qt)

CAUTION:

Hard water or salt water is harmful to the engine parts. You may use distilled water, if you can't get soft water.

8. Install:
 - Radiator capStart the engine and warm it up for a several minute.
9. Check:
 - Cooling water levelCooling water level low → Add cooling water.
10. Install the lower cowl.

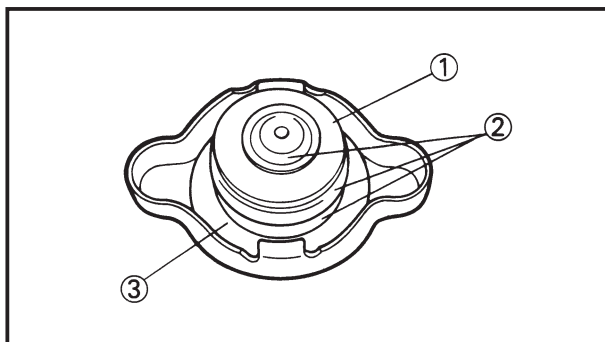

EC355000

RADIATOR CAP INSPECTION

1. Inspect:
 - Seal (radiator cap) ①
 - Valve and valve seat ②Crack/Damage → Replace.
Exist fur deposits ③ → Clean or replace.

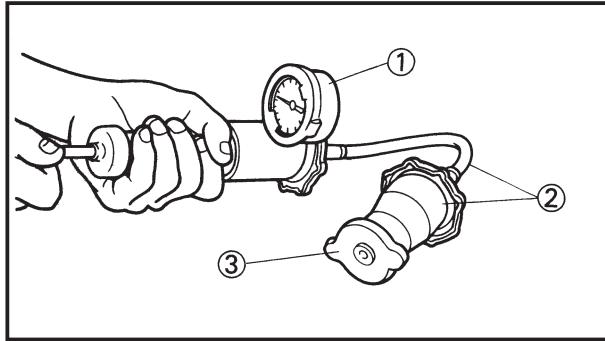

EC356001

RADIATOR CAP OPENING PRESSURE INSPECTION

1. Attach:
 - Radiator cap tester ① and adapter ②



Radiator cap tester:
YU-24460-1/90890-01325
Adapter:
YU-33984/90890-01352

NOTE: _____

Apply water on the radiator cap seal.

- ③ Radiator cap
2. Apply the specified pressure.



Radiator cap opening pressure:
95~125 kPa (0.95~1.25 kg/cm²,
13.5~17.8 psi)

3. Inspect:
 - Pressure

Impossible to maintain the specified pressure for 10 seconds → Replace.

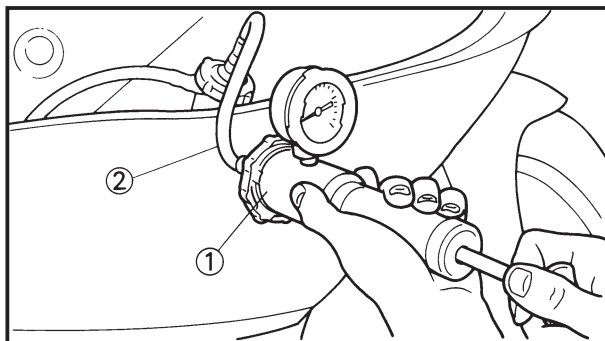

EC357002

COOLING SYSTEM INSPECTION

1. Inspect:
 - Coolant level
2. Attach:
 - Radiator cap tester ① and adapter ②



Radiator cap tester:
YU-24460-1/90890-01325
Adapter:
YU-33984/90890-01352

3. Apply the specified pressure.



Standard pressure:
180 kPa (1.8 kg/cm², 25.6 psi)

NOTE: _____

- Do not apply pressure more than specified pressure.
- Radiator should be filled fully.

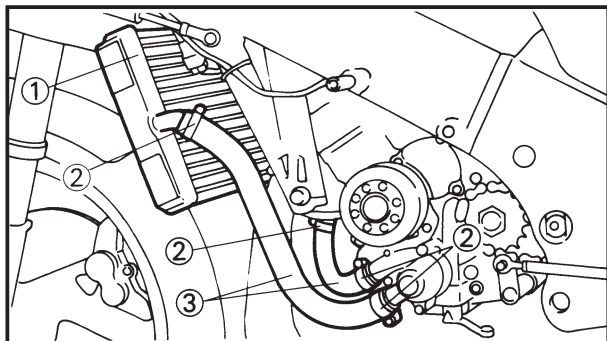

4. Inspect:
 - Pressure
Impossible to maintain the specified pressure for 10 seconds → Repair.
 - Radiator ①
 - Radiator hose joint ②
Coolant leakage → Repair or replace.
 - Radiator hose ③
Swelling → Replace.

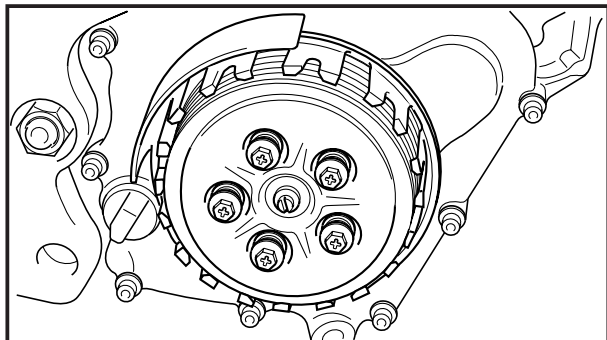

EC358000

CLUTCH CARE

NOTE:

This machine is equipped with a dry type clutch. Be sure to clean with solvent or replace if grease or oil contacts either clutch or friction plates.

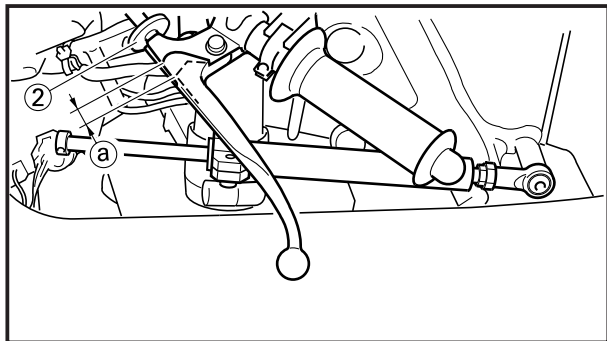

EC359001

CLUTCH ADJUSTMENT

1. Check:
 - Clutch lever free play ①
Out of specification → Adjust.



Clutch lever free play ①:
2~3 mm (0.08~0.12 in)

2. Adjust:
 - Clutch lever free play

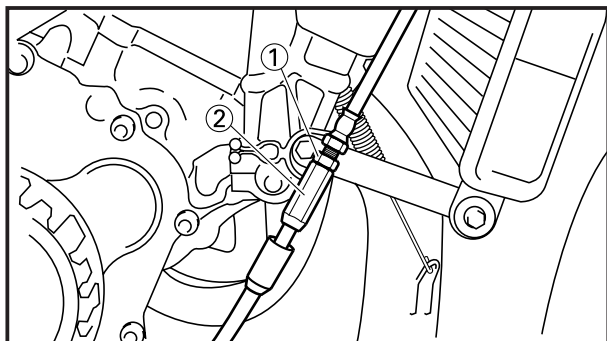

Clutch lever free play adjustment steps:

- Loosen the locknut ①.
- Turn the adjuster ② until free play ① is within the specified limits.
- Tighten the locknut.

NOTE:

After adjustment, check proper operation of clutch lever.

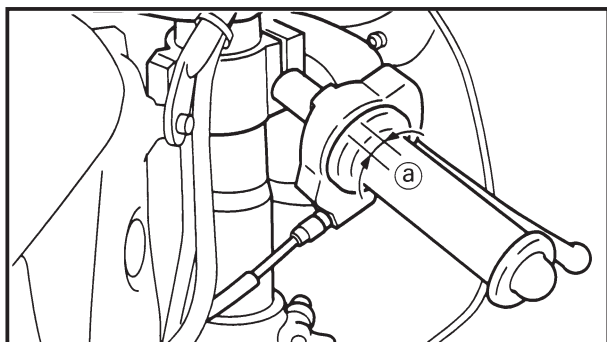

EC35A011

THROTTLE CABLE ADJUSTMENT

1. Check:
 - Throttle grip free play ①
Out of specification → Adjust.



Throttle grip free play ①:
2~4 mm (0.08~0.16 in)

TRANSMISSION OIL LEVEL CHECK

INSP
ADJ

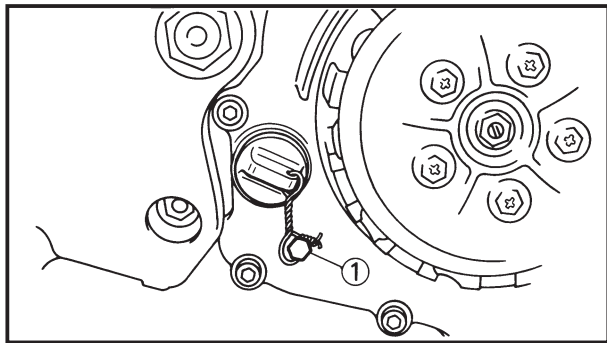
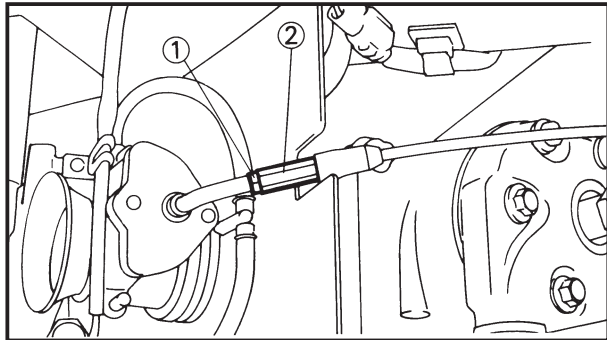
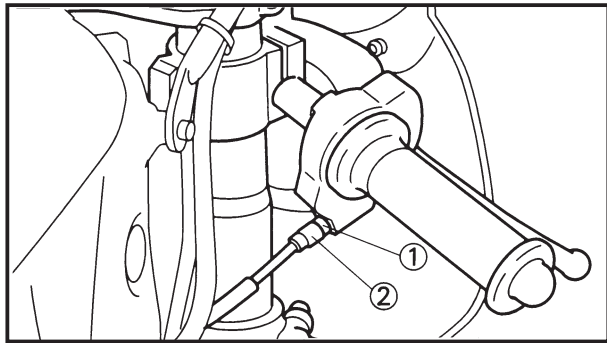

2. Adjust:
 - Throttle grip free play

Throttle grip free play adjustment steps:

- Loosen the locknut ①.
- Turn the adjuster ② until the specified free play is obtained.
- Tighten the locknut.

⚠WARNING

After adjusting, turn the handlebar to right and left and make sure that the engine idling does not run faster.

EC35H030

TRANSMISSION OIL LEVEL CHECK

1. Start the engine, warm it up for several minutes and wait for five minutes.
2. Place the machine on a level place and hold it up on upright position by placing the suitable stand.
3. Check:
 - Transmission oil level

Transmission oil level checking steps:

- Remove the oil check bolt ①.
- Inspect the oil level.

NOTE:

Be sure the machine is positioned straight up when inspecting the oil level.

⚠WARNING

Never attempt to remove the checking bolt just after high speed operation. The heated oil could spout out, causing danger. Wait until the oil cools down.

Oil flows out → Oil level is correct.

Oil does not flow out → Oil level is low.
Add transmission oil until oil flows out.



Recommended oil:
Castrol R30

- Inspect the gasket (oil check bolt), replace if damaged.
- Tighten the oil check bolt.



Oil check bolt:
9 Nm (0.9 m•kg, 6.5 ft•lb)



EC35K012

TRANSMISSION OIL REPLACEMENT

1. Start the engine and warm it up for several minutes and wait for five minutes.
2. Place the machine on a level place and hold it on upright position by placing the suitable stand.
3. Place a suitable container under the engine.

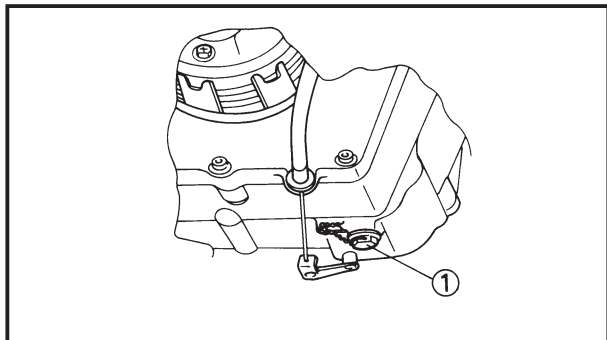

4. Remove:

- Exhaust pipe
- Oil drain bolt ①
- Oil filler cap ②

Drain the transmission oil.

5. Install:

- Copper washer **New**
- Oil drain bolt ①

23 Nm (2.3 m•kg, 17 ft•lb)

- Exhaust pipe

NOTE:

After tightening the oil drain bolt to specified torque, lock it using a wire.

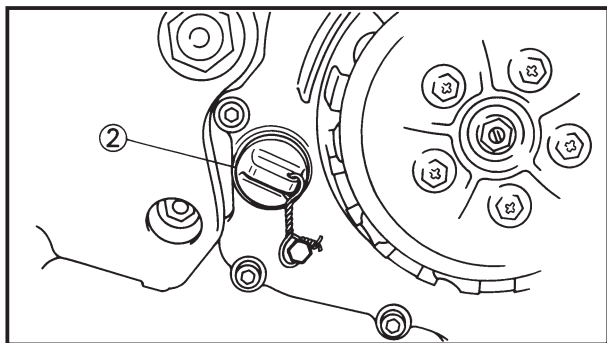

6. Fill:

- Transmission oil



Recommended oil:

Castrol R30

Oil capacity

(periodic oil change):

0.30 L (0.26 Imp qt, 0.32 US qt)

7. Check:

- Oil leakage

8. Check:

- Transmission oil level

9. Install:

- Oil filler cap ②

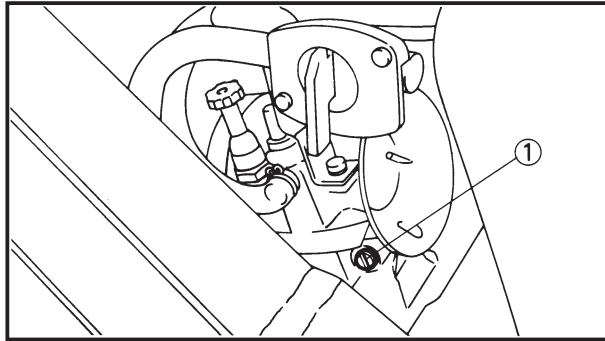

EC35L030

PILOT AIR SCREW ADJUSTMENT

1. Adjust:
 - Pilot air screw ①

Adjusting steps:

- Turn in the pilot air screw until it is lightly seated.
- Turn out the pilot air screw by the factory-set number of turns.

NOTE:

To optimize the fuel flow at a smaller throttle opening, each machine's pilot air screw has been individually set at the factory. Before adjusting the pilot air screw, turn it in fully and count the number of turns. Record this number as the factory-set number of turns out.



Pilot air screw:
Factory-set number of turns out

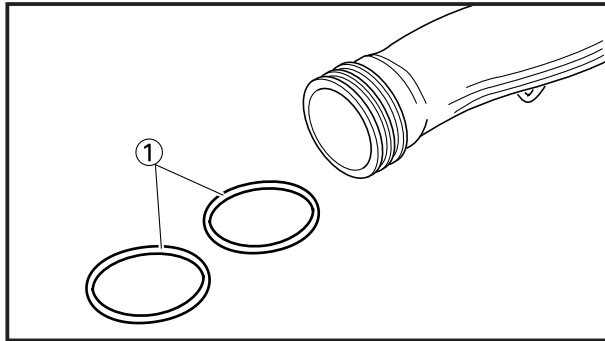

EC35P010

MUFFLER INSPECTION

1. Inspect:
 - O-ring ①Damage → Replace.

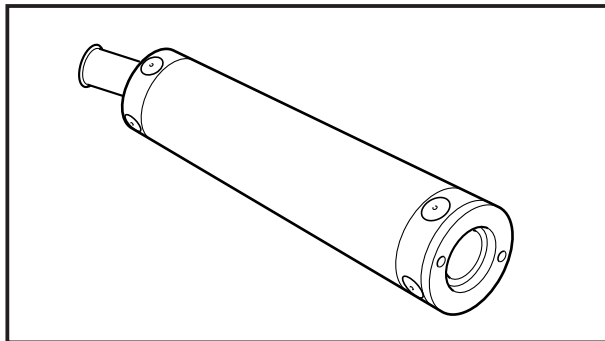

EC35Q001

SILENCER INSPECTION

1. Inspect:
 - SilencerInside of silencer loose → Repair.

Silencer repair steps:

- Drill the silencer for riveting.
- Rivet the silencer using the rivet.

NOTE:

Rivet the silencer in a different area than previously riveted.



EC360000

CHASSIS

EC361002

BRAKE SYSTEM AIR BLEEDING

⚠WARNING

Bleed the brake system if:

- The system has been disassembled.
- A brake hose has been loosened or removed.
- The brake fluid is very low.
- The brake operation is faulty.

A dangerous loss of braking performance may occur if the brake system is not properly bleed.

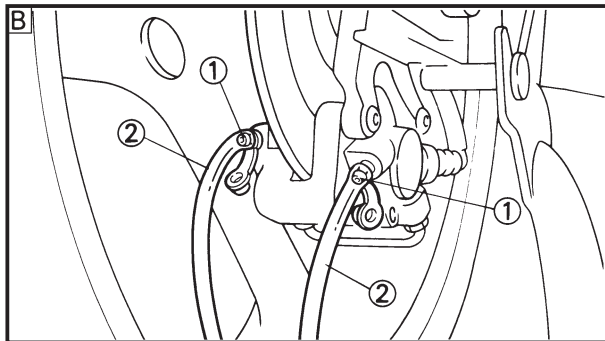
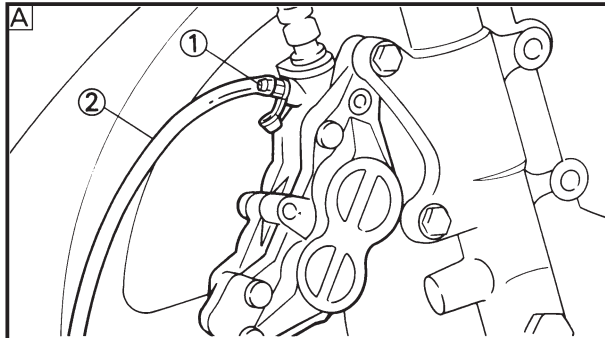

1. Remove:
 - Reservoir tank cap
 - Diaphragm
2. Bleed:
 - Brake fluid

A Front

B Rear

Air bleeding steps:

- a. Add proper brake fluid to the reservoir.
- b. Install the diaphragm. Be careful not to spill any fluid or allow the reservoir to overflow.
- c. Connect the clear plastic tube ② tightly to the caliper bleed screw ①.
- d. Place the other end of the tube into a container.
- e. Slowly apply the brake lever or pedal several times.
- f. Pull the lever in or push down on the pedal. Hold the lever or pedal in position.
- g. Loosen the bleed screw and allow the lever or pedal to travel towards its limit.
- h. Tighten the bleed screw when the lever or pedal limit has been reached; then release the lever or pedal.



Bleed screw:

6 Nm (0.6 m•kg, 4.3 ft•lb)

- i. Repeat steps (e) to (h) until of the air bubbles have been removed from the system.



NOTE: _____

If bleeding is difficult, it may be necessary to let the brake fluid system stabilize for a few hours. Repeat the bleeding procedure when the tiny bubbles in the system have disappeared.

- j. Add brake fluid to the level line on the reservoir.

⚠ WARNING _____

Check the operation of the brake after bleeding the brake system.

3. Install:
 - Diaphragm
 - Reservoir tank cap

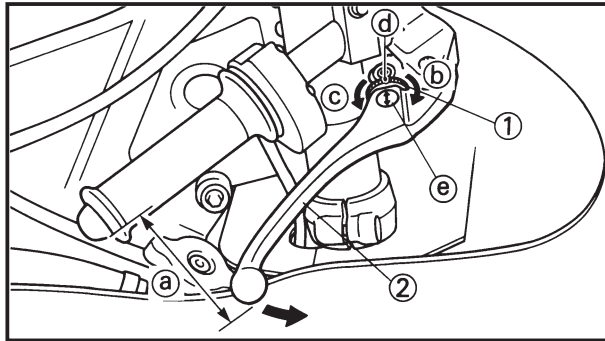

EC363010

FRONT BRAKE ADJUSTMENT

1. Adjust:
 - Brake lever position (a)

Adjustment steps:

- Turn the adjuster ① while pushing the brake lever ② forward until the desired lever position is obtained.

Closer → Turn the adjuster in (b).
Farther → Turn the adjuster out (c).

NOTE: _____

Align the mating mark (d) on the adjuster with the arrow mark (e) on the brake lever.

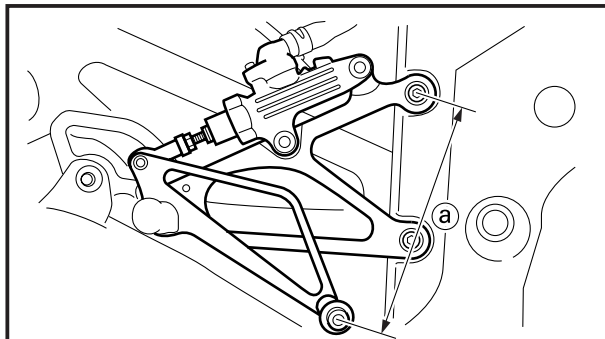

EC364011

REAR BRAKE ADJUSTMENT

1. Check:
 - Brake pedal height (a)
 Out of specification → Adjust.



Brake pedal height (a):
148~152 mm (5.8~6.0 in)

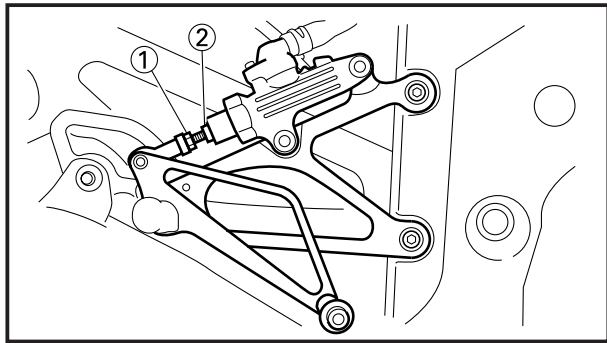

2. Adjust:
- Brake pedal height

Pedal height adjustment steps:

- Loosen the locknut ①.
- Turn the adjusting nut ② until the pedal height is within specified height.
- Tighten the locknut.

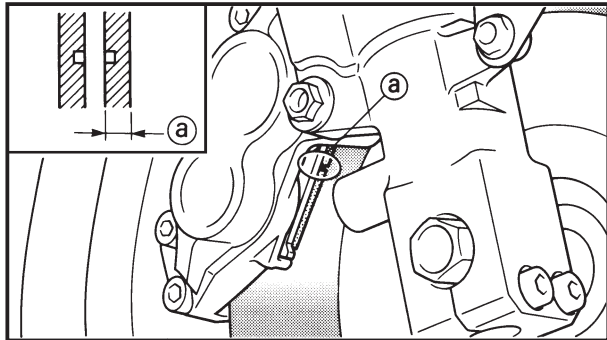

EC365050

FRONT BRAKE PAD INSPECTION AND REPLACEMENT

1. Inspect:
- Brake pad thickness ①
- Out of specification → Replace as a set.



Brake pad thickness ①:

Standard	<Limit>
5.3 mm (0.21 in)	1.0 mm (0.04 in)

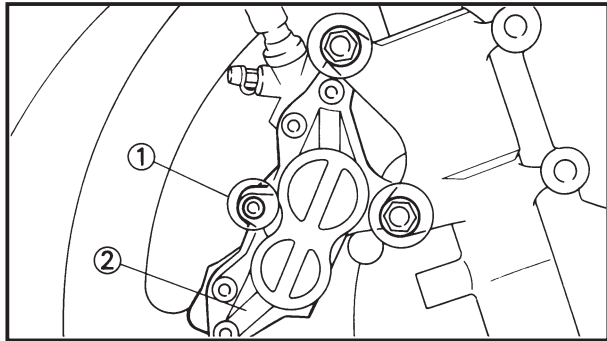

2. Replace:
- Brake pad

Brake pad replacement steps:

- Loosen the pad pin ① and remove the caliper ②.
- Remove the cotter pin ③, pad pin ④, pad support ⑤ and brake pads ⑥.
- Connect the transparent hose ⑦ to the bleed screw ⑧ and place the suitable container under its end.
- Loosen the bleed screw and push the caliper piston in.

CAUTION:

Do not reuse the drained brake fluid.

- Tighten the bleed screw.

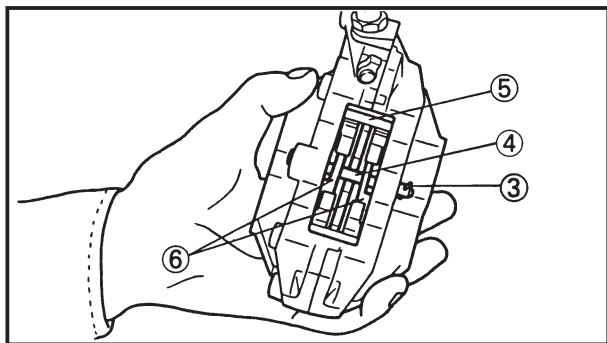

Bleed screw:

6 Nm (0.6 m•kg, 4.3 ft•lb)

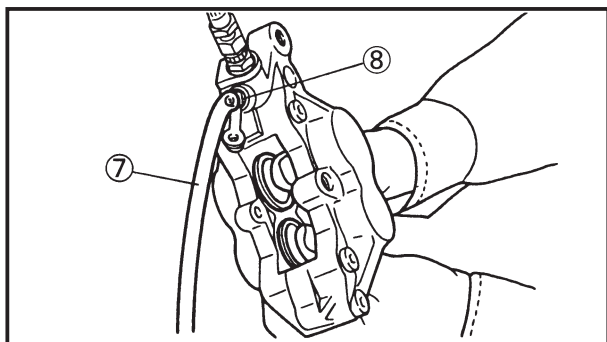

REAR BRAKE PAD INSPECTION AND REPLACEMENT

INSP
ADJ

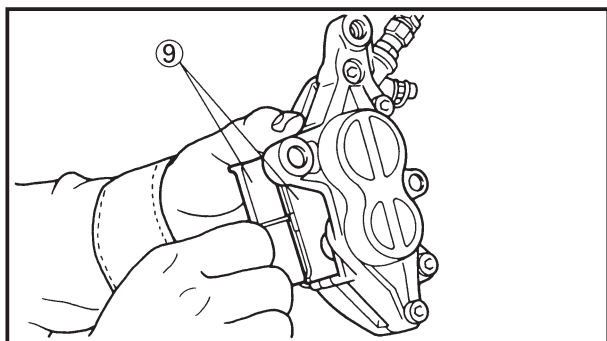

- Install the brake pads ⑨, pad support ⑩, pad pin ⑪ and cotter pin ⑫.

NOTE: _____

- Always use a new cotter pin.
- Temporarily tighten the pad pin at this point.

- Install the caliper ⑬ and tighten the pad pin ⑭.

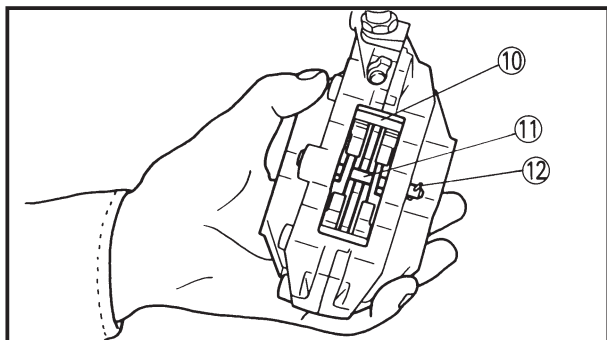

Bolt (caliper):

35 Nm (3.5 m•kg, 25 ft•lb)

Pad pin:

18 Nm (1.8 m•kg, 13 ft•lb)

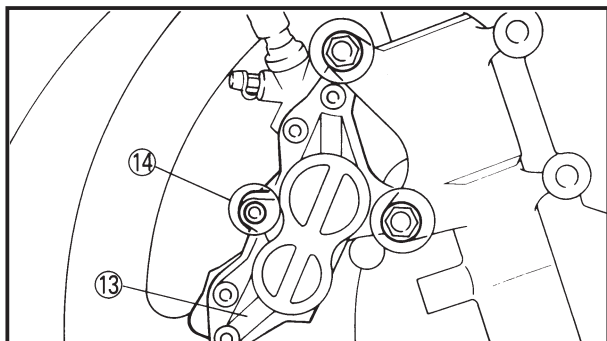

3. Inspect:
 - Brake fluid level
Refer to “BRAKE FLUID LEVEL INSPECTION” section.
4. Check:
 - Brake lever operation
A softy or spongy feeling → Bleed brake system.
Refer to “BRAKE SYSTEM AIR BLEEDING” section.

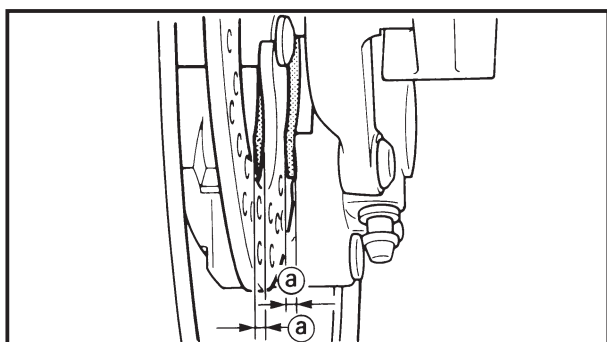

EC366031

REAR BRAKE PAD INSPECTION AND REPLACEMENT

1. Inspect:
 - Brake pad thickness ①
Out of specification → Replace as a set.



Brake pad thickness ①:

Standard	<Limit>
4.0 mm (0.16 in)	1.0 mm (0.04 in)

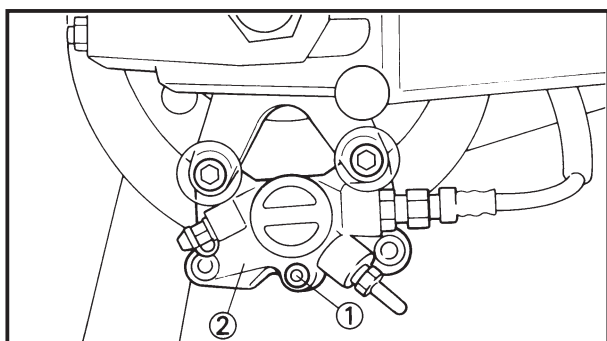

2. Replace:
 - Brake pad

Brake pad replacement steps:

- Loosen the pad pin ① and remove the caliper ②.

NOTE: _____

Before removing the caliper from the swingarm, loosen the pad pin.

REAR BRAKE PAD INSPECTION AND REPLACEMENT

INSP
ADJ

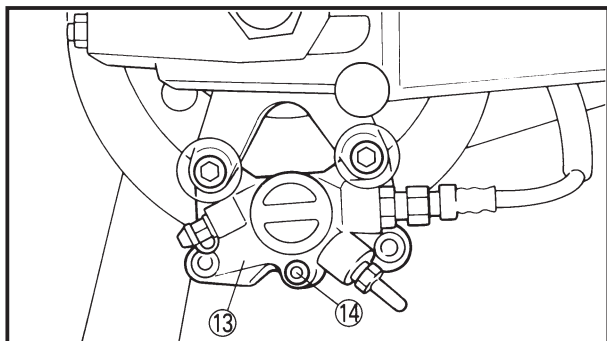
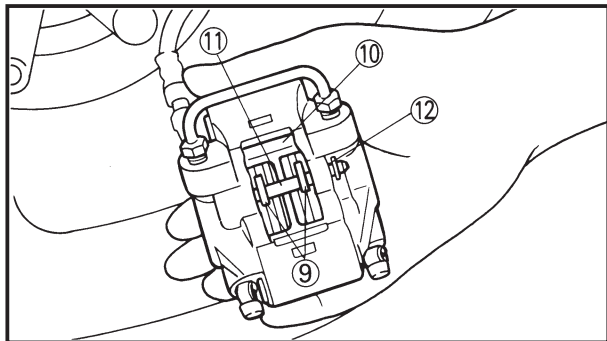
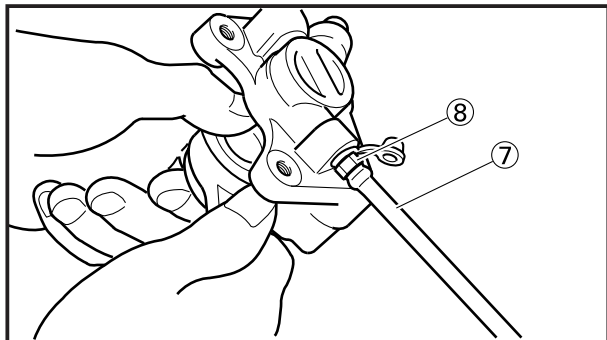
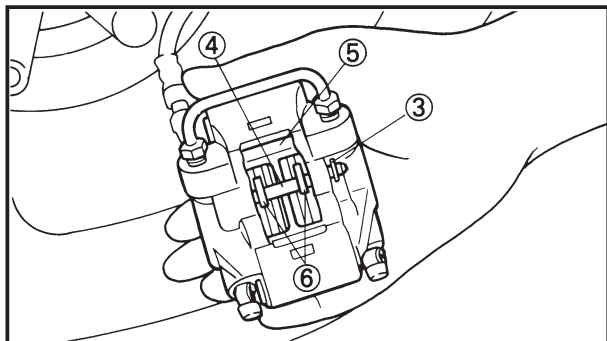

- Remove the cotter pin ③, pad pin ④, pad support ⑤ and brake pads ⑥.
- Connect the transparent hose ⑦ to the bleed screw ⑧ and place the suitable container under its end.
- Loosen the bleed screw and push the caliper piston in.

CAUTION:

Do not reuse the drained brake fluid.

- Tighten the bleed screw.



Bleed screw:

6 Nm (0.6 m•kg, 4.3 ft•lb)

- Install the brake pads ⑨, pad support ⑩, pad pin ⑪ and cotter pin ⑫.

NOTE:

- Always use a new cotter pin.
- Temporarily tighten the pad pin at this point.
- Install the caliper ⑬ and tighten the pad pin ⑭.



Bolt (caliper):

23 Nm (2.3 m•kg, 17 ft•lb)

Pad pin:

18 Nm (1.8 m•kg, 13 ft•lb)

3. Inspect:

- Brake fluid level
Refer to "BRAKE FLUID LEVEL INSPECTION" section.

4. Check:

- Brake pedal operation
A softy or spongy feeling → Bleed brake system.
Refer to "BRAKE SYSTEM AIR BLEEDING" section.

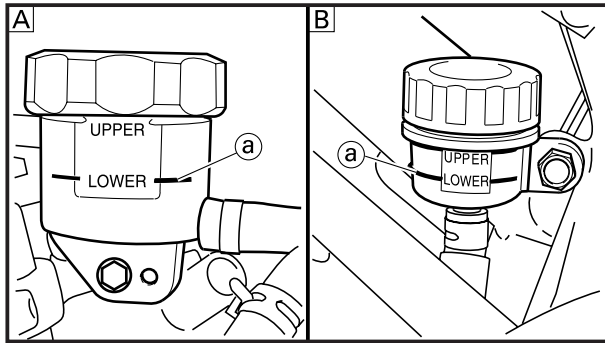

EC367001

BRAKE FLUID LEVEL INSPECTION

1. Place the master cylinder so that its top is in a horizontal position.
2. Inspect:
 - Brake fluid level
Fluid at lower level → Fill up.

Ⓐ Lower level

Ⓐ Front

Ⓑ Rear



**Recommended brake fluid:
DOT #4**

⚠ WARNING

- Use only designated quality brake fluid to avoid poor brake performance.
- Refill with same type and brand of brake fluid; mixing fluids could result in poor brake performance.
- Be sure that water or other contaminants do not enter master cylinder when refilling.
- Clean up spilled fluid immediately to avoid erosion of painted surfaces or plastic parts.

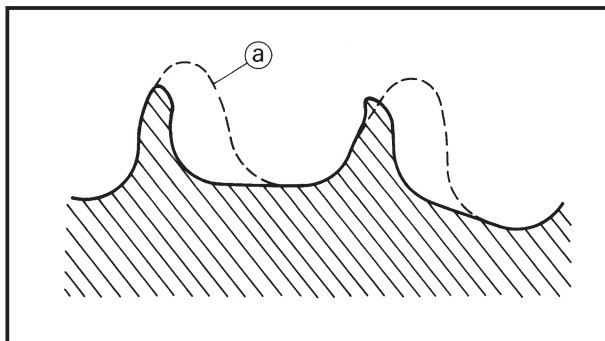

EC368011

SPROCKETS INSPECTION

1. Inspect:
 - Sprocket teeth Ⓐ
Excessive wear → Replace.

NOTE:

Replace the drive, driven sprockets and drive chain as a set.

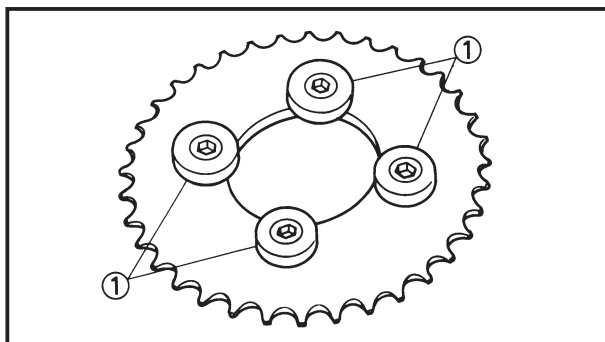

2. Inspect:
 - Sprocket damper ①
Wear/Damage → Replace.

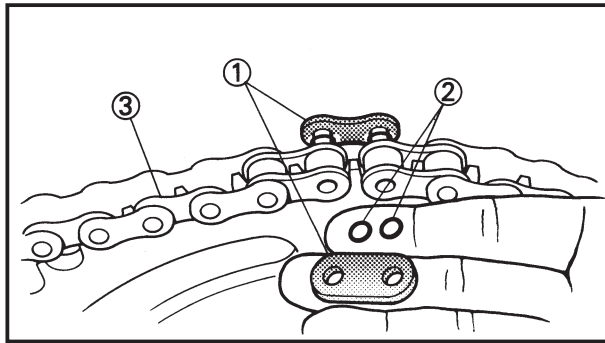

EC369051

DRIVE CHAIN INSPECTION

1. Remove:

- Master link clip
- Joint ①
- O-ring ②
- Drive chain ③

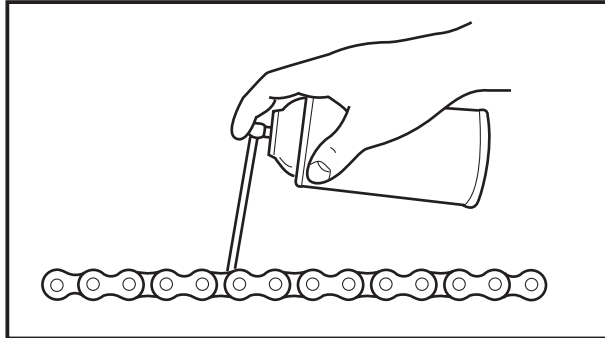

2. Clean:

- Drive chain
- Brush off as much dirt as possible. Then clean the chain using the chain cleaner.

CAUTION:

This machine has a drive chain with small rubber O-rings ① between the chain plates. Steam cleaning, high-pressure washes, certain solvent and kerosene can damage these O-rings.

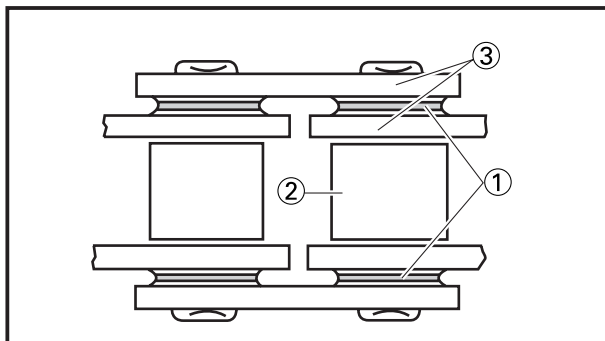
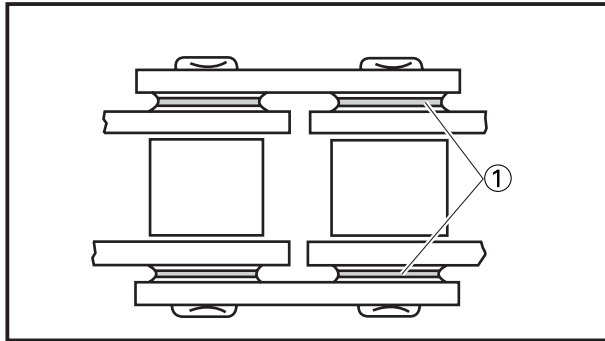

3. Inspect:

- O-rings ① (drive chain)
Damage → Replace drive chain.
- Rollers ②
- Side plates ③
Damage/Wear → Replace drive chain.

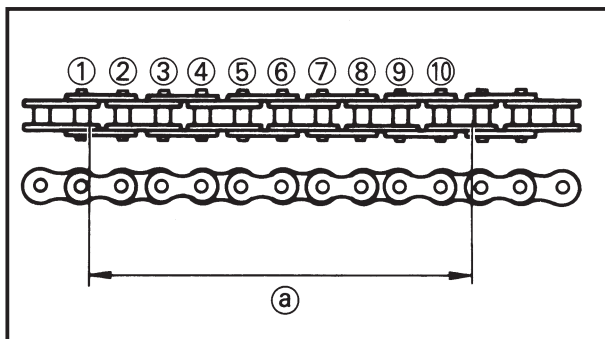

4. Measure:

- Drive chain length (10 links) @
Out of specification → Replace.



Drive chain length (10 links):
Limit: 120.0 mm (4.724 in)

DRIVE CHAIN SLACK ADJUSTMENT

INSP
ADJ

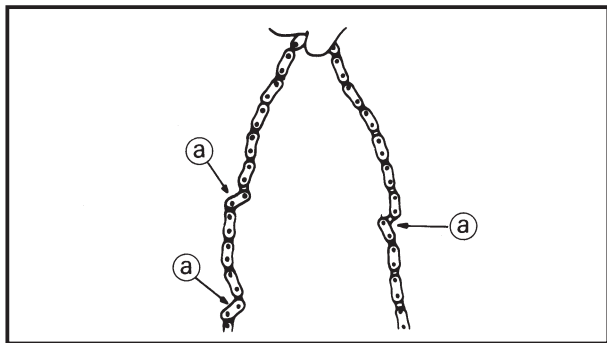

5. Check:

- Drive chain stiffness (a)

Clean and oil the chain and hold as illustrated.

Stiff → Replace drive chain.

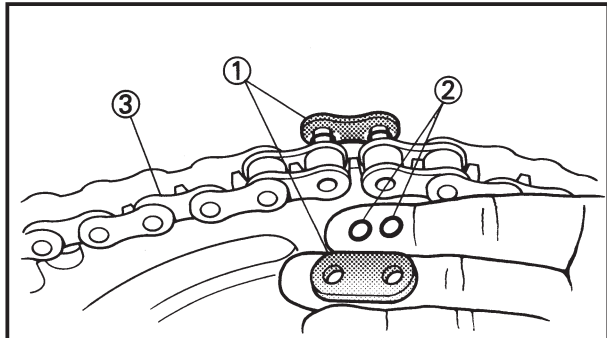

6. Install:

- Joint ①
- O-ring ②
- Drive chain ③
- Master link clip ④ **New**

CAUTION:

Be sure to install the master link clip to the direction as shown.

(a) Turning direction

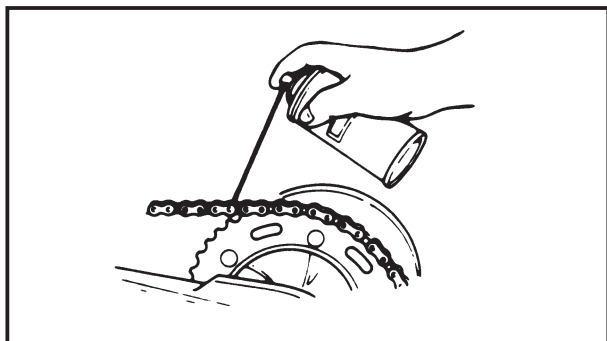
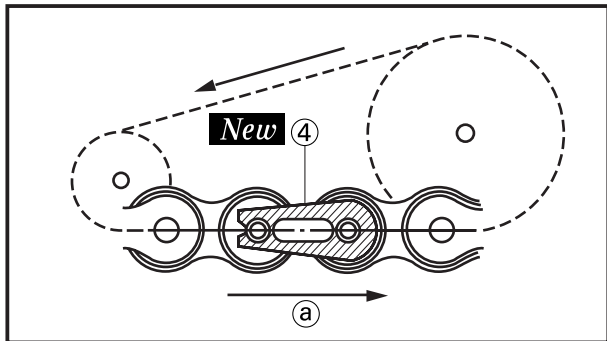

7. Lubricate:

- Drive chain

	<p>Drive chain lubricant: SAE 30~50W motor oil or chain lubricants suitable for "O-ring" chains</p>
--	--

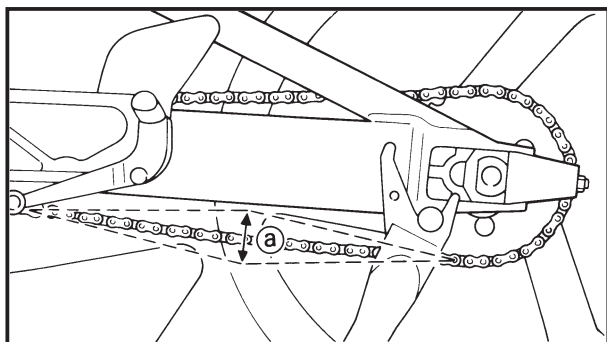

EC36A042

DRIVE CHAIN SLACK ADJUSTMENT

1. Hold the machine on upright position by placing the suitable stand.

2. Check:

- Drive chain slack (a)

Out of specification → Adjust.

	<p>Drive chain slack: 30~40 mm (1.2~1.6 in)</p>
--	--



NOTE:

Before checking and/or adjusting, rotate the rear wheel through several revolutions and check the slack several times to find the tightest point. Check and/or adjust chain slack with rear wheel in this “tight chain” position.

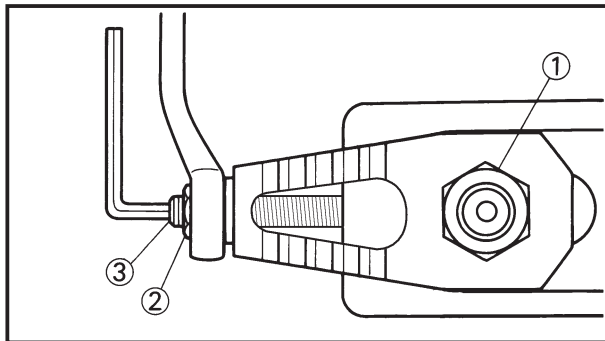
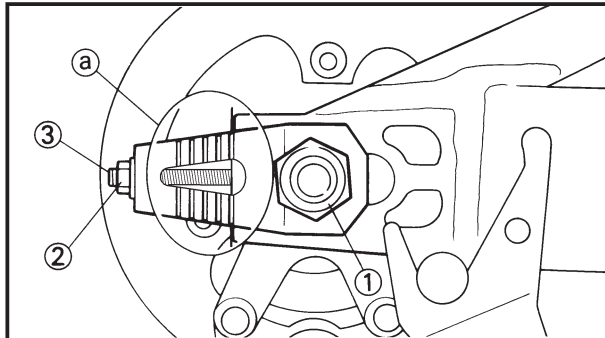

- Adjust:
 - Drive chain slack

Drive chain slack adjustment steps:

- Loosen the axle nut ① and locknuts ②.
- Adjust chain slack by turning the adjusters ③.

To tighten → Turn adjuster ③ counter-clockwise.

To loosen → Turn adjuster ③ clockwise.

- Turn each adjuster exactly the same amount to maintain correct axle alignment. (There are marks Ⓐ on each side of chain puller alignment.)

NOTE:

Turn the adjuster so that the chain is in line with the sprocket, as viewed from the rear.

CAUTION:

Too small chain slack will overload the engine and other vital parts; keep the slack within the specified limits.

- Tighten the axle nut while pushing down the drive chain.



Axle nut:
63 Nm (6.3 m•kg, 45 ft•lb)

- Turn out the adjusters to the specified torque.



Adjuster:
2 Nm (0.2 m•kg, 1.4 ft•lb)

- Tighten the locknuts.



Locknut:
16 Nm (1.6 m•kg, 11 ft•lb)

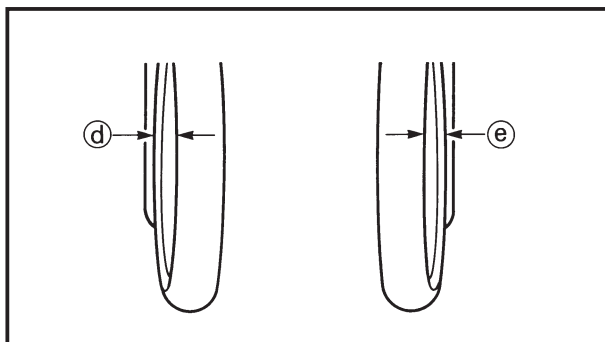
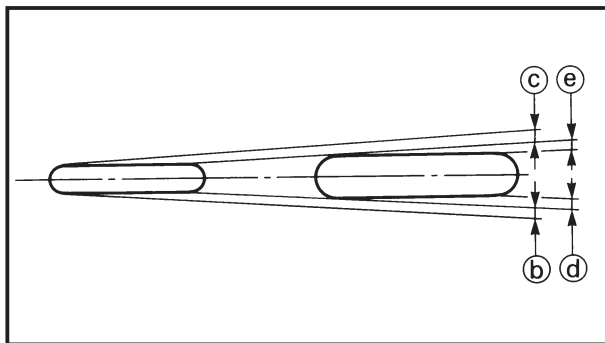
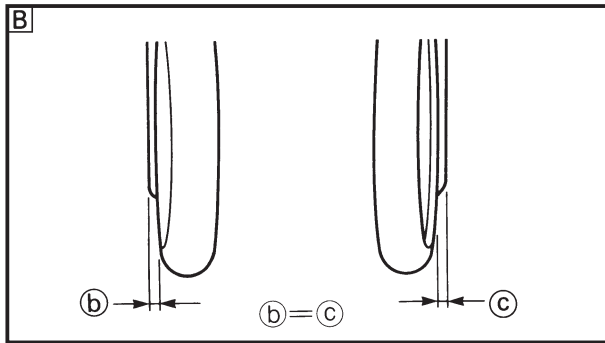
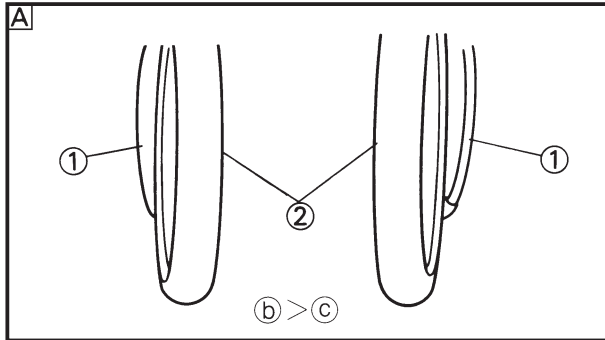
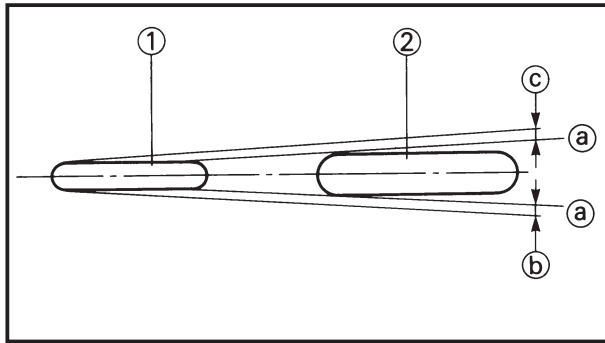

EC36B000

WHEEL ALIGNMENT ADJUSTMENT

1. Remove:
 - Lower cowl
2. Place the machine on a level place and hold it up on upright position.
3. Sit 1~2 m (3.3~6.6 ft) behind the machine and look at both sides of the wheels below the rear wheel axle.
4. Turn the handlebar left and right to make the front wheel straight.

NOTE: _____

- To make the front wheel straight, provide **(b)** and **(c)** with the same distance as seen along the extension of the line **(a)** connecting the rear end of the front wheel **(1)** and the front end of the rear wheel **(2)**.
 - Figure **A** shows that the front wheel is turned clockwise ($b > c$).
 - Figure **B** shows that the front wheel is straight ($b = c$).
-

5. Check:

- Wheel alignment
 With the front wheel straight ($b = c$), check whether the distances **(d)** and **(e)** are equal.
 If not → Adjust.

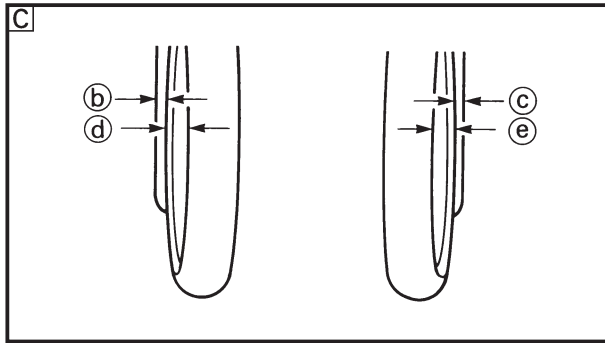

6. Adjust:

- Wheel alignment

Turn the chain puller adjuster while paying attention to the drive chain slack and make adjustment while moving the rear wheel.

NOTE:

- Figure [C] shows that the wheel alignment has been correctly made ((b) = (c) and (d) = (e)).
- After the adjustment, record the difference in the graduation between the left and right chain pullers as it will provide convenience in your future similar adjustment.

7. Install:

- Lower cowl

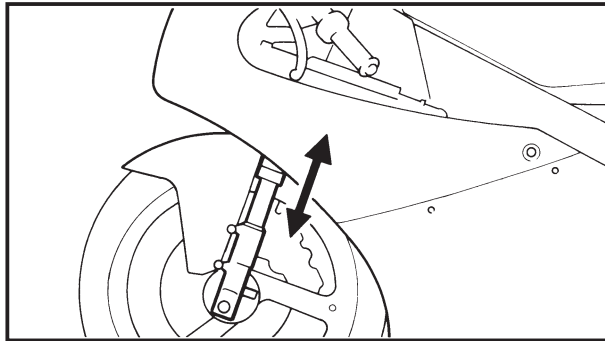

EC36C000

FRONT FORK INSPECTION

1. Inspect:

- Front fork smooth action

Operate the front brake and stroke the front fork.

Unsmooth action/oil leakage → Repair or replace.

EC36E002

FRONT FORK TOP END ADJUSTMENT

1. Hold the machine on upright position by placing the suitable stand.

2. Remove:

- Cowling
- Front wheel
- Front fender

3. Adjust:

- Front fork top end

Adjustment steps:

- Loosen the pinch bolts (handle bracket and steering damper stay).
- Loosen the pinch bolts (handle crown and under bracket).

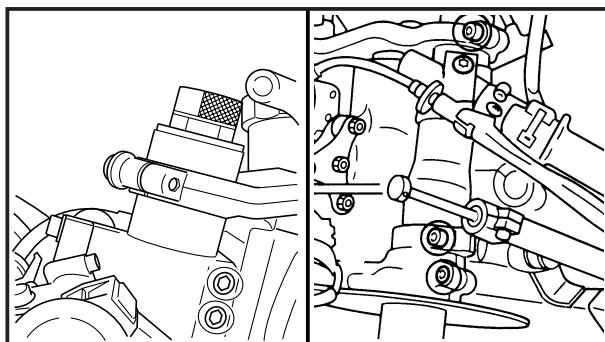

FRONT FORK TOP END ADJUSTMENT

**INSP
ADJ**

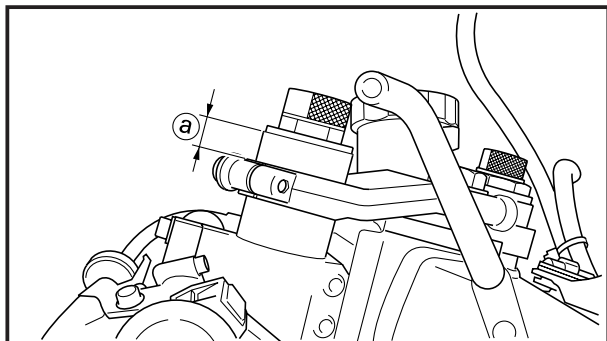

- Adjust the front fork top end (a).



Front fork top end (a):

Standard	Extent of adjustment
18 mm (0.71 in)	Zero~20 mm (Zero~0.79 in)

CAUTION:

Never attempt to install the front fork beyond the maximum or minimum setting.

WARNING

Always adjust each front fork to the same setting. Uneven adjustment can cause poor handling and loss of stability.

- Tighten the pinch bolts (handle crown and under bracket).

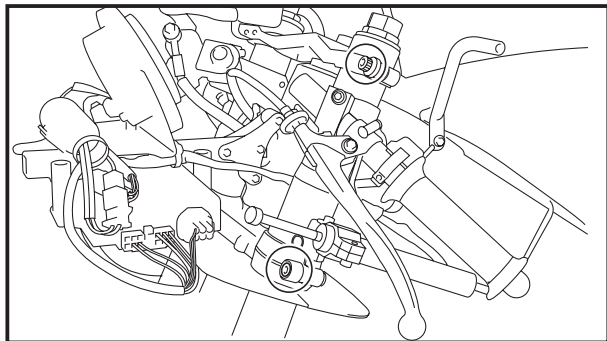

Pinch bolt (handle crown):
15 Nm (1.5 m•kg, 11 ft•lb)
Pinch bolt (under bracket):
20 Nm (2.0 m•kg, 14 ft•lb)

CAUTION:

Tighten the under bracket to specified torque. If torqued too much, it may cause the front fork to malfunction.

- Adjust the handlebar position (b) and steering damper stay position (c).

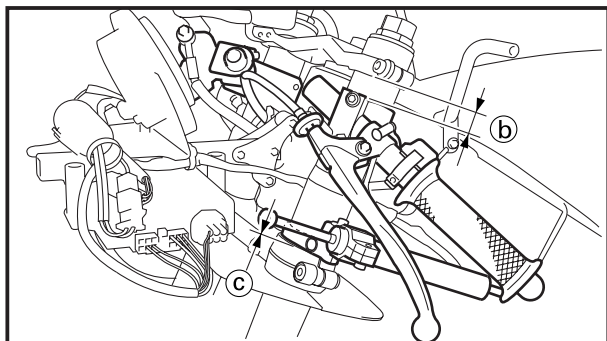

Handlebar position (b):
20 mm (0.79 in)
Steering damper stay position (c):
Zero mm (Zero in)

- Tighten the pinch bolts (handle bracket and steering damper stay).

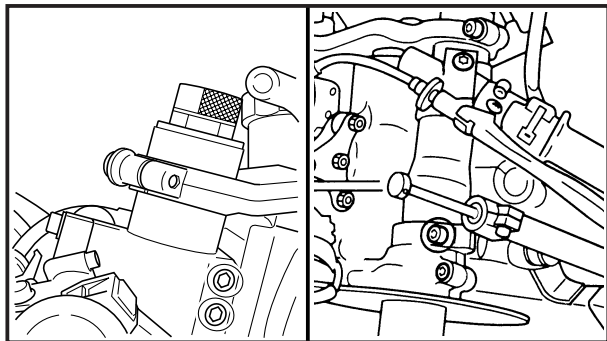

Pinch bolt (handle bracket):
8 Nm (0.8 m•kg, 5.8 ft•lb)
Pinch bolt (steering damper stay):
7 Nm (0.7 m•kg, 5.1 ft•lb)

FRONT FORK SPRING PRELOAD ADJUSTMENT

**INSP
ADJ**

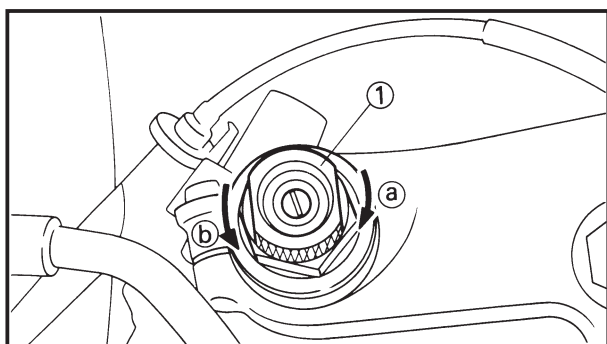
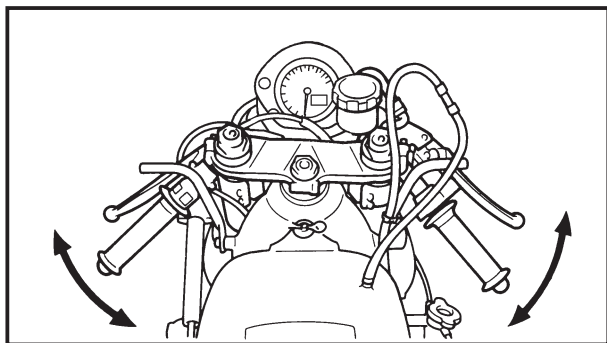
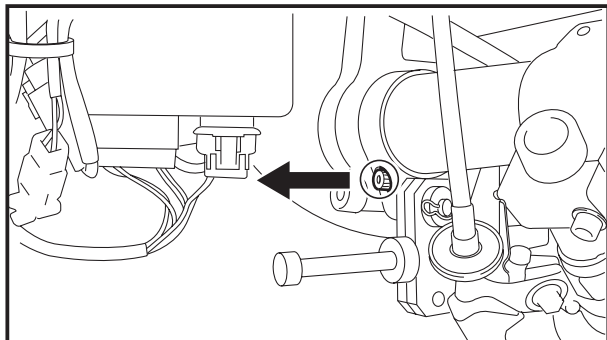
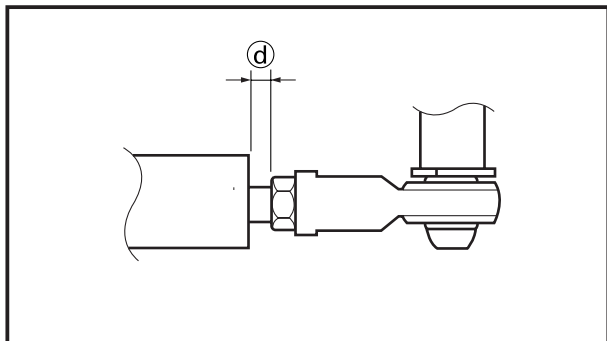

CAUTION:

Tighten the pinch bolts to specified torque. If torqued too much, it may cause the front fork to malfunction.

NOTE:

- Adjust the installation angle of the steering damper stay so that the dimension ① is between 3 mm (0.12 in) and 5 mm (0.20 in) when the handlebar is turned fully to the left.
- Tighten the pinch bolt (steering damper stay) toward the front of the chassis.

4. Check:
 - Steering smooth action
Turn the handlebar to make sure no parts are being contacted with others.
Contact → Repair.
5. Install:
 - Front fender
 - Front wheel
 - Cowling

EC36F012

FRONT FORK SPRING PRELOAD ADJUSTMENT

1. Adjust:
 - Spring preload
By turning the adjuster ①.

Stiffer ① → Increase the spring preload.
(Turn the adjuster ① in.)
Softer ② → Decrease the spring preload.
(Turn the adjuster ① out.)



Extent of adjustment:

Maximum	Minimum
Fully turned-in position	Fully turned-out position

FRONT FORK REBOUND DAMPING FORCE ADJUSTMENT



- **STANDARD POSITION:**
This is the position which is back by the specific number of clicks from the fully turned-out position.

	Standard position: 2 clicks in
--	--

NOTE: _____

- Fully turn out the adjuster and then turn it in. Specify the position in which the first click is heard as the zero position . If a click is heard just when the adjuster is fully turned out, this position is zero.
- Preload is 0.5 mm (0.02 in) changed per click of the adjuster.

CAUTION: _____

Do not force the adjuster past the minimum or maximum extent of adjustment. The adjuster may be damaged.

WARNING _____

Always adjust each front fork to the same setting. Uneven adjustment can cause poor handling and loss of stability.

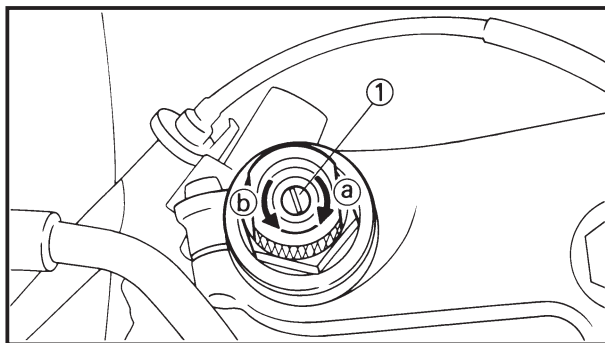

EC36H010

FRONT FORK REBOUND DAMPING FORCE ADJUSTMENT

1. Adjust:
 - Rebound damping force
By turning the adjuster ①.

Stiffer ①	→ Increase the rebound damping force. (Turn the adjuster ① in.)
Softer ②	→ Decrease the rebound damping force. (Turn the adjuster ① out.)

	Extent of adjustment:	
	Maximum	Minimum
	Fully turned-in position	Fully turned-out position

FRONT FORK COMPRESSION DAMPING FORCE ADJUSTMENT

**INSP
ADJ**



- **STANDARD POSITION:**
This is the position which is back by the specific number of clicks from the fully turned-in position.



**Standard position:
8 clicks out**

NOTE:
Fully turn in the adjuster and then turn it out. Specify the position in which the first click is heard as the zero position. If a click is heard just when the adjuster is fully turned in, this position is zero.

CAUTION:

Do not force the adjuster past the minimum or maximum extent of adjustment. The adjuster may be damaged.

WARNING

Always adjust each front fork to the same setting. Uneven adjustment can cause poor handling and loss of stability.

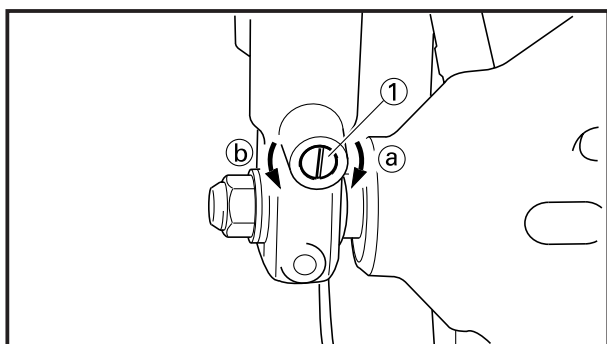

EC36J030

FRONT FORK COMPRESSION DAMPING FORCE ADJUSTMENT

1. Adjust:
 - Compression damping force
By turning the adjuster ①.

Stiffer ① → Increase the compression damping force. (Turn the adjuster ① in.)

Softer ② → Decrease the compression damping force. (Turn the adjuster ① out.)



Extent of adjustment:

Maximum	Minimum
Fully turned-in position	Fully turned-out position



• **STANDARD POSITION:**

This is the position which is back by the specific number of clicks from the fully turned-in position.



Standard position:
8 clicks out

NOTE:

Fully turn in the adjuster and then turn it out. Specify the position in which the first click is heard as the zero position. If a click is heard just when the adjuster is fully turned in, this position is zero.

CAUTION:

Do not force the adjuster past the minimum or maximum extent of adjustment. The adjuster may be damaged.

WARNING

Always adjust each front fork to the same setting. Uneven adjustment can cause poor handling and loss of stability.

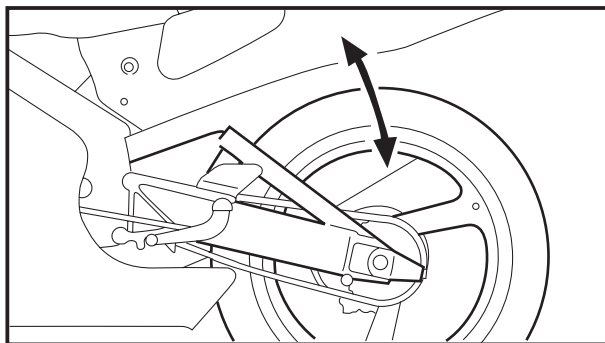

EC36K000

REAR SHOCK ABSORBER INSPECTION

1. Inspect:

- Swingarm smooth action

Abnormal noise/Unsmooth action → Grease the pivoting points or repair the pivoting points.

Damage/Oil leakage → Replace.

EC36L001

SEAT HEIGHT ADJUSTMENT

1. Remove:

- Fuel tank

2. Adjust:

- Seat height

REAR SHOCK ABSORBER SPRING PRELOAD ADJUSTMENT

INSP
ADJ

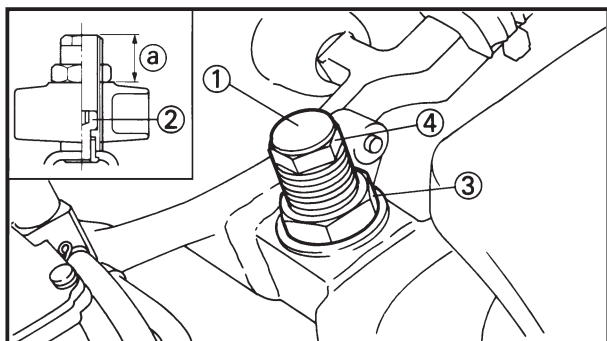

Seat height adjustment steps:

- Remove the cap ①.
- Loosen the lock bolt ② and locknut ③.
- Turn the adjuster ④ in or out.



Adjuster set length ②:

Standard length	Extent of adjustment
19 mm (0.75 in)	15~25 mm (0.59~0.98 in)

NOTE:

If the adjuster set length ② is changed, the seat height will be increased or decreased by twice the change.

CAUTION:

Never attempt to turn the adjuster beyond the maximum or minimum length.

- Tighten the lock bolt and locknut.



Lock bolt:

40 Nm (4.0 m•kg, 29 ft•lb)

Locknut:

38 Nm (3.8 m•kg, 27 ft•lb)

- Install the cap.

3. Install:

- Fuel tank

EC36M051

REAR SHOCK ABSORBER SPRING PRELOAD ADJUSTMENT

1. Hold the machine on upright position by placing the suitable stand.
2. Loosen:
 - Locknut ①

NOTE:

When loosening the locknut, use the special tool ② which is included in the owner's tool kit.

3. Adjust:

- Spring preload
By turning the adjuster ③.

Stiffer → Increase the spring preload.
(Turn the adjuster ③ in.)
Softer → Decrease the spring preload.
(Turn the adjuster ③ out.)

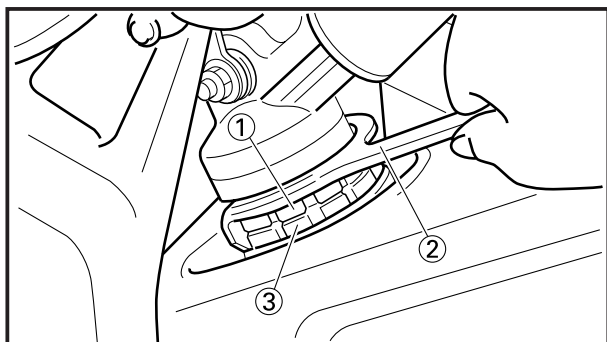

REAR SHOCK ABSORBER REBOUND DAMPING FORCE ADJUSTMENT

**INSP
ADJ**

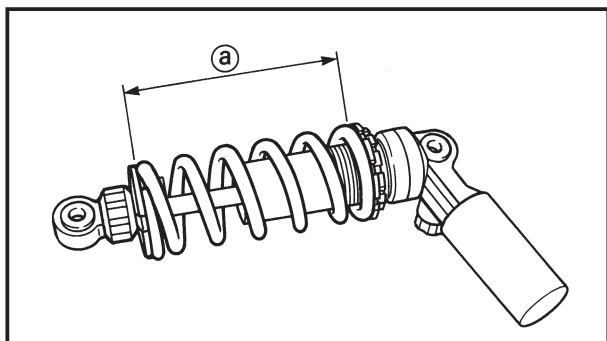

Spring length (installed) ①:	
Standard length	Extent of adjustment
138 mm (5.43 in)	130~150 mm (5.12~5.91 in)

NOTE:
The length of the spring (installed) changes 1.5 mm (0.06 in) per turn of the adjuster.

CAUTION:
Never attempt to turn the adjuster beyond the maximum or minimum setting.

4. Tighten:
- Locknut 40 Nm (4.0 m•kg, 29 ft•lb)

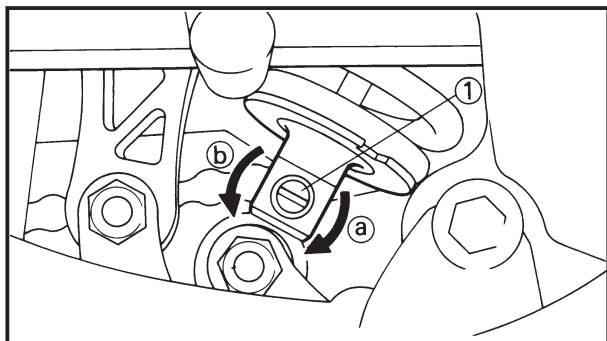

EC36N030
REAR SHOCK ABSORBER REBOUND DAMPING FORCE ADJUSTMENT

1. Adjust:
- Rebound damping force
By turning the adjuster ①.

Stiffer ① → Increase the rebound damping force. (Turn the adjuster ① in.)
Softer ② → Decrease the rebound damping force. (Turn the adjuster ① out.)

Extent of adjustment:	
Maximum	Minimum
Fully turned-in position	Fully turned-out position

• **STANDARD POSITION:**
This is the position which is back by the specific number of clicks from the fully turned-in position. (Which align the punch mark ① on the adjuster with the punch mark ② on the bracket.)

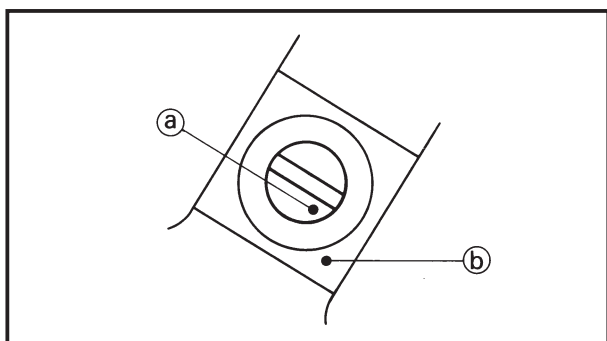

Standard position:
About 18 clicks out



NOTE: Fully turn in the adjuster and then turn it out. Specify the position in which the first click is heard as the zero position. If a click is heard just when the adjuster is fully turned in, this position is zero.

CAUTION: Do not force the adjuster past the minimum or maximum extent of adjustment. The adjuster may be damaged.

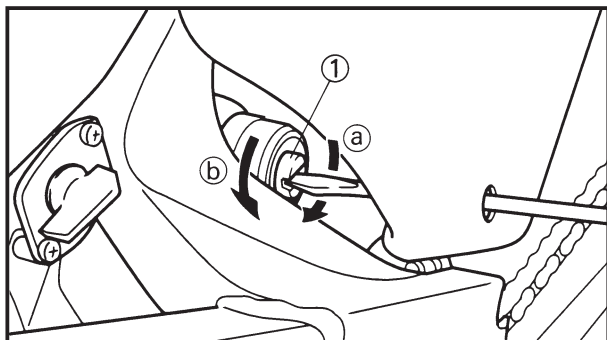

EC36P030

REAR SHOCK ABSORBER COMPRESSION DAMPING FORCE ADJUSTMENT

- Adjust:
 - Compression damping force
By turning the adjuster ①.

Stiffer ① → Increase the compression damping force. (Turn the adjuster ① in.)
Softer ② → Decrease the compression damping force. (Turn the adjuster ① out.)



Extent of adjustment:

Maximum	Minimum
Fully turned-in position	Fully turned-out position

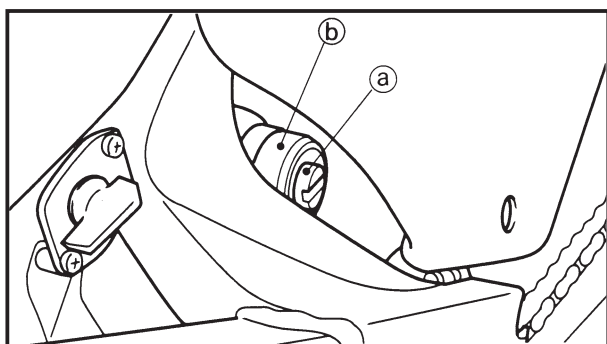

- **STANDARD POSITION:**
This is the position which is back by the specific number of clicks from the fully turned-in position. (Which align the punch mark ① on the adjuster with the punch mark ② on the bracket.)



Standard position:
About 18 clicks out

NOTE: Fully turn in the adjuster and then turn it out. Specify the position in which the first click is heard as the zero position. If a click is heard just when the adjuster is fully turned in, this position is zero.



CAUTION: _____

Do not force the adjuster past the minimum or maximum extent of adjustment. The adjuster may be damaged.

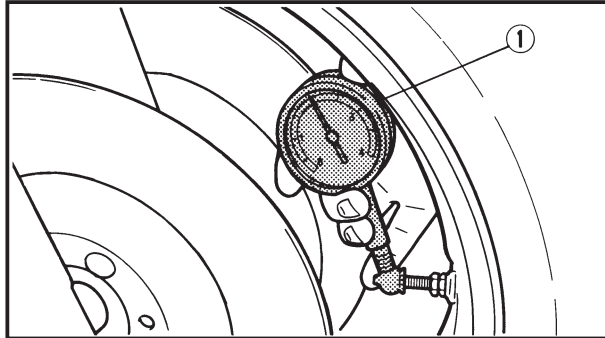

EC36Q011

TIRE PRESSURE CHECK

1. Measure:
 - Tire pressure
 Out of specification → Adjust.

	Standard tire pressure:	
	Front	Rear
	180 kPa (1.8 kg/cm², 26 psi)	180 kPa (1.8 kg/cm², 26 psi)

NOTE: _____

Check the tire while it is cold.

① Air gauge

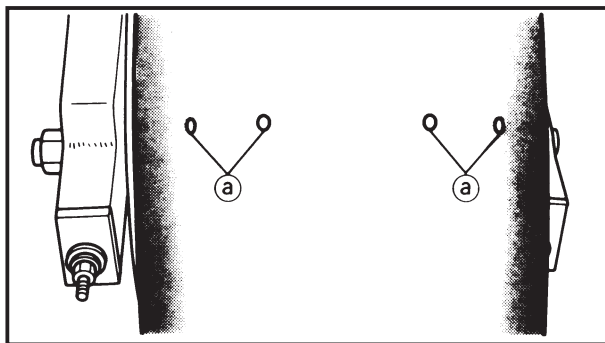

EC36R000

TIRE INSPECTION

1. Inspect:
 - Tire surfaces
 Wear/Damage → Replace.

	Minimum tire tread depth (a):
	2 mm (0.08 in)

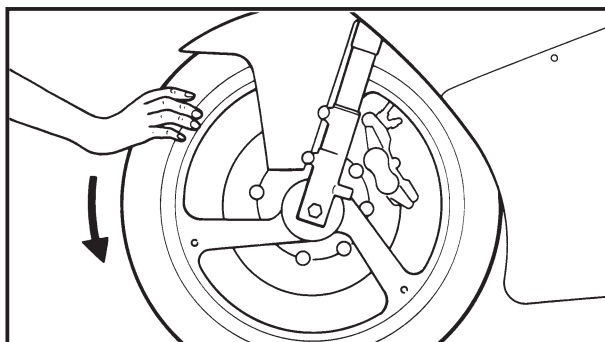

EC36T000

WHEEL INSPECTION

1. Inspect:
 - Wheel runout
 Elevate the wheel and turn it.
 Abnormal runout → Replace.

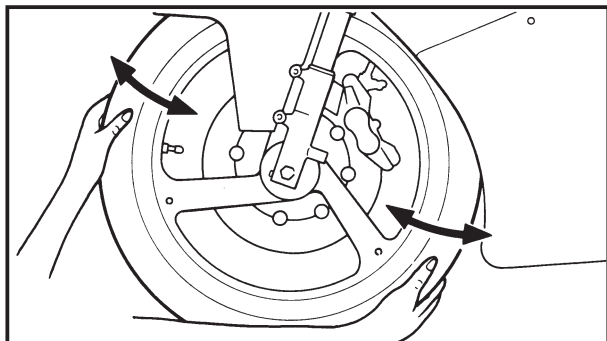

2. Inspect:
 - Bearing free play
 - Exist play → Replace.

EC36U060

STEERING HEAD INSPECTION AND ADJUSTMENT

1. Remove the steering damper at front fork side.
2. Elevate the front wheel by placing a suitable stand.

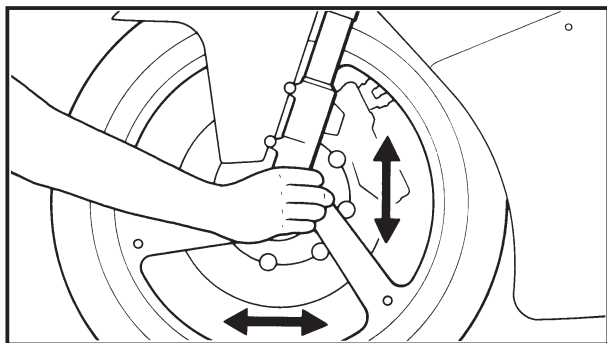

3. Check:
 - Steering stem
 - Grasp the bottom of the forks and gently rock the fork assembly back and forth.
 - Free play → Adjust steering head.

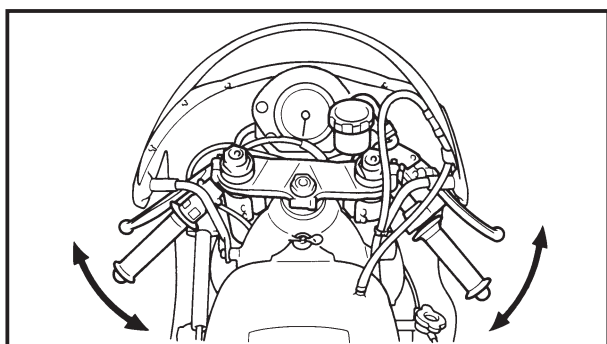

4. Check:
 - Steering smooth action
 - Turn the handlebar lock to lock.
 - Unsmooth action → Adjust steering ring nut.

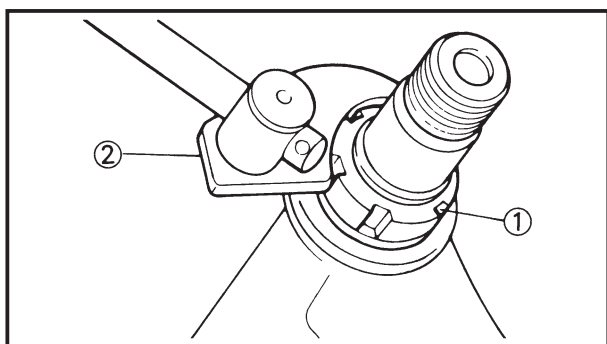

5. Adjust:
 - Steering ring nut

Steering ring nut adjustment steps:

- Remove the cowling.
- Remove the reservoir tank and handle crown.
- Loosen the ring nut ① using ring nut wrench ②.



Ring nut wrench:
YU-33975/90890-01403

STEERING DAMPER ADJUSTMENT

**INSP
ADJ**

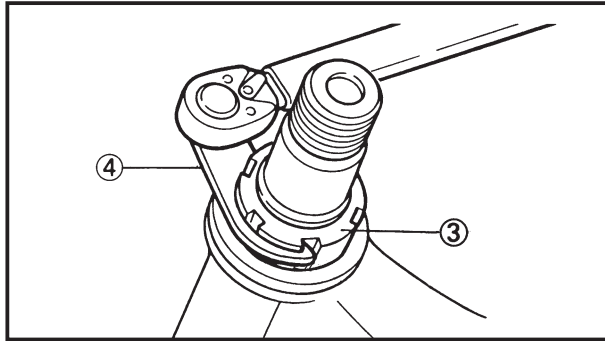

- Tighten the ring nut ③ using ring nut wrench ④.

NOTE: _____
Set the torque wrench to the ring nut wrench so that they form a right angle.



Ring nut wrench:
YU-33975/90890-01403



Ring nut (initial tightening):
46 Nm (4.6 m•kg, 33 ft•lb)

- Loosen the ring nut one turn.
- Retighten the ring nut using the ring nut wrench.

⚠ WARNING _____
Avoid over-tightening.



Ring nut (final tightening):
1 Nm (0.1 m•kg, 0.7 ft•lb)

- Check the steering shaft by turning it lock to lock. If there is any binding, remove the steering shaft assembly and inspect the steering bearings.
- Install the handle crown ⑤ and reservoir tank ⑥.



Steering shaft nut ⑦:
80 Nm (8.0 m•kg, 58 ft•lb)
Pinch bolt (front fork) ⑧:
15 Nm (1.5 m•kg, 11 ft•lb)
Bolt (reservoir tank) ⑨:
5 Nm (0.5 m•kg, 3.6 ft•lb)

- Install the cowling.

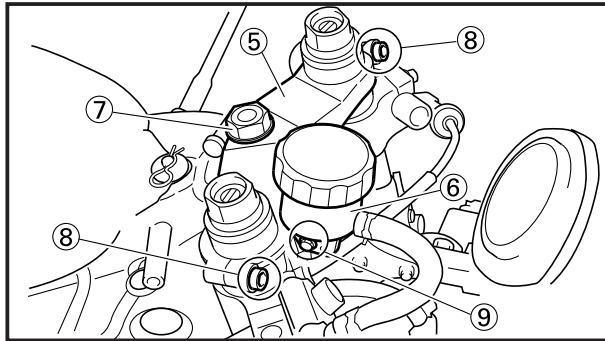

6. Install:
- Steering damper

EC36V002

STEERING DAMPER ADJUSTMENT

1. Adjust:
- Damping force
By turning the adjuster ①.

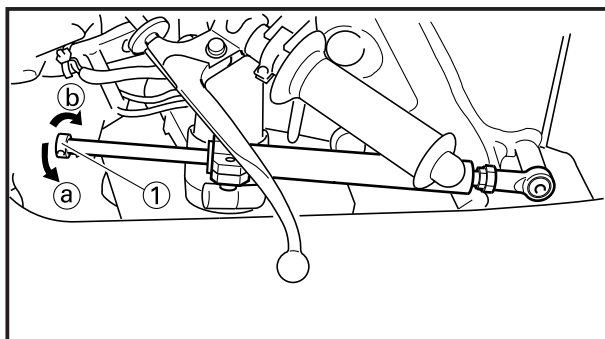

Stiffer (a) → Increase the compression damping force. (Turn the adjuster ① in.)
Softer (b) → Decrease the compression damping force. (Turn the adjuster ① out.)



	Extent of adjustment:	
	Maximum	Minimum
	Fully turned-in position	Fully turned-out position

- **STANDARD POSITION:**
This is the position which is back by the specific number of clicks from the fully turned-out position.

	Standard position:
	0 click in

NOTE: _____
Fully turn out the adjuster and then turn it in. Specify the position in which the first click is heard as the zero position . If a click is heard just when the adjuster is fully turned out, this position is zero.

CAUTION: _____
Do not force the adjuster past the minimum or maximum extent of adjustment. The adjuster may be damaged.

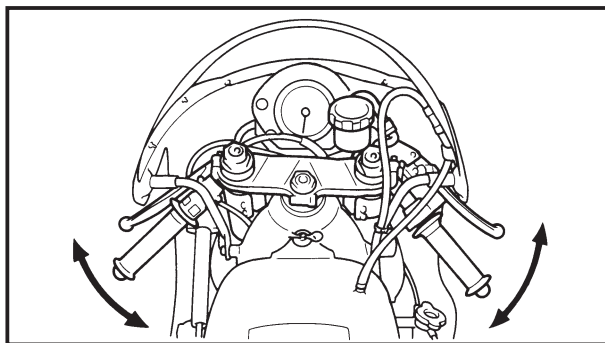

EC36X001

WIRES, CABLES

1. Inspect:
 - Smooth movement for steering handle
By turning the handlebar lock to lock.
If any caught/rubbed → Repair/Replace.

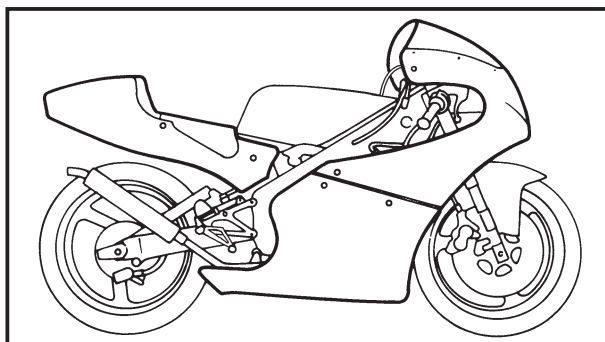

EC36Z000

COWLING INSTALLATION INSPECTION

1. Inspect:
 - Cowling
Loosen → Tighten.
Stroke the front fork to make sure no parts are being contacted with others.
Contact → Repair or replace.
 - Screen
Scratches/fogging → Clean or replace.



EC36a023

LUBRICATION

To ensure smooth operation of all components lubricate your machine during setup, after break-in, and after every race.

- ① All control cable
- ② Brake and clutch lever pivots
- ③ Throttle-to-handlebar contact
- ④ Drive chain
- ⑤ Throttle cable end
- ⑥ Clutch cable end

- A Use Yamaha cable lube or equivalent on these areas.
- B Use SAE 10W30 motor oil or suitable chain lubricants.
- C Lubricate the following areas with high quality, lightweight lithium-soap base grease.

CAUTION:

Wipe off any excess grease, and avoid getting grease on the brake discs.

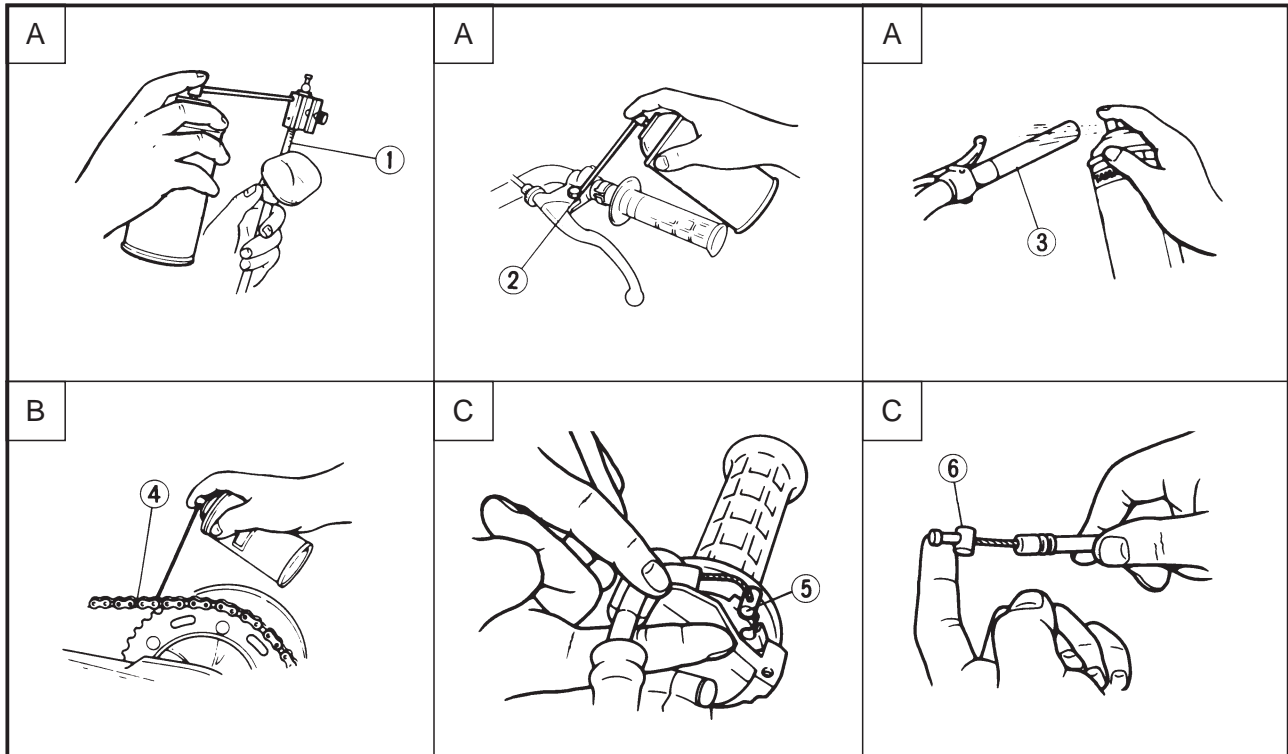

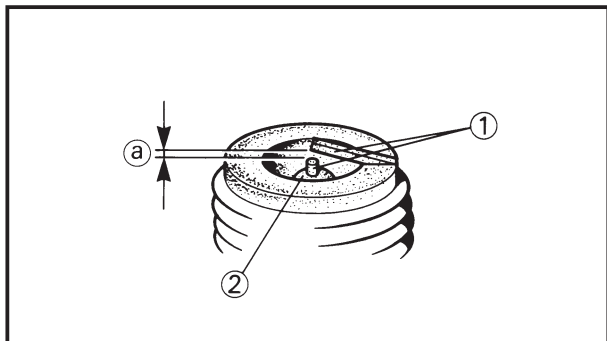

EC370000

ELECTRICAL

EC371001

SPARK PLUG INSPECTION

1. Remove:
 - Spark plug
2. Inspect:
 - Electrode ①
Wear/Damage → Replace.
 - Insulator color ②
Normal condition is a medium to light tan color.
Distinctly different color → Check the engine condition.

NOTE: _____

When the engine runs for many hours at low speeds, the spark plug insulator will become sooty, even if the engine and carburetor are in good operating condition.

3. Measure:
 - Plug gap ③
Use a wire gauge or thickness gauge.
Out of specification → Regap.



Spark plug gap:
0.5~0.6 mm (0.020~0.024 in)

Standard spark plug:
R6385-105P

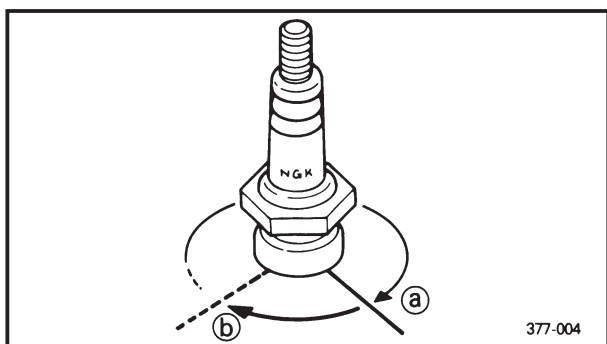

4. Clean the plug with a spark plug cleaner if necessary.
5. Tighten:
 - Spark plug  **19 Nm (1.9 m•kg, 13 ft•lb)**

NOTE: _____

- Before installing a spark plug, clean the gasket surface and plug surface.
- Finger-tighten ③ the spark plug before torquing to specification ④.

EC372022

IGNITION TIMING CHECK

1. Remove:
 - Cowling
 - Fuel tank
 - Spark plug

IGNITION TIMING CHECK

INSP
ADJ

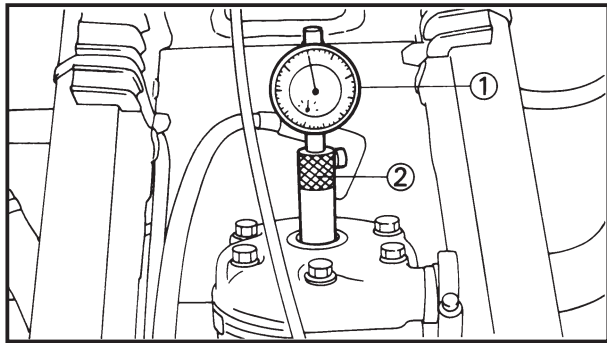

2. Attach:
 - Dial gauge ①
 - Dial gauge stand ②



Dial gauge:
YU-03097/90890-01252
Stand:
YU-01256

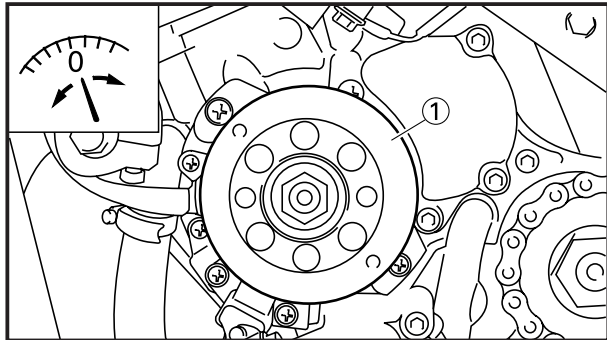

3. Rotate the magneto rotor ① until the piston reaches top dead center (TDC). When this happens, the needle on the dial gauge will stop and reverse directions even though the rotor is being turned in the same direction.
4. Set the dial gauge to zero at TDC.

5. From TDC, rotate the rotor clockwise until the dial gauge indicates that the piston is at a specified distance from TDC.



Ignition timing (B.T.D.C.):
2.3 mm (0.091 in)

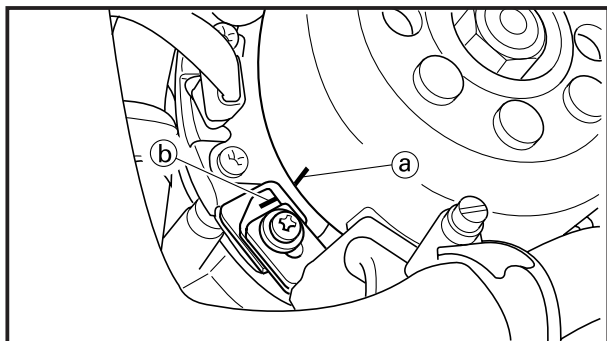

6. Check:
 - Ignition timing
Punch mark (a) on rotor should be aligned with punch mark (b) on pick-up coil.
Not aligned → Adjust.

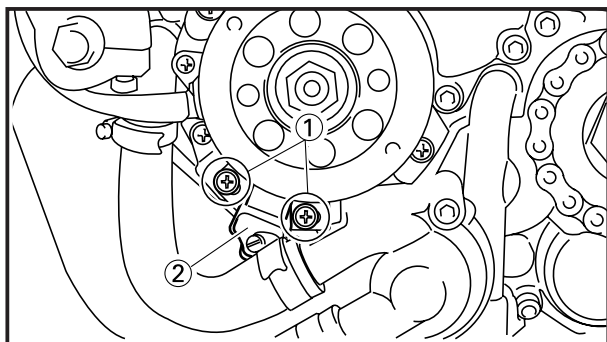

7. Adjust:
 - Ignition timing

Adjustment steps:

- Loosen the screws (pick-up coil) ①.
- Align the punch marks by moving the pick-up coil ②.
- Tighten the screws (pick-up coil).



Screw (pick-up coil):
2 Nm (0.2 m•kg, 1.4 ft•lb)

EC400000

ENGINE

EC4U0000

COWLING, SEAT AND FUEL TANK

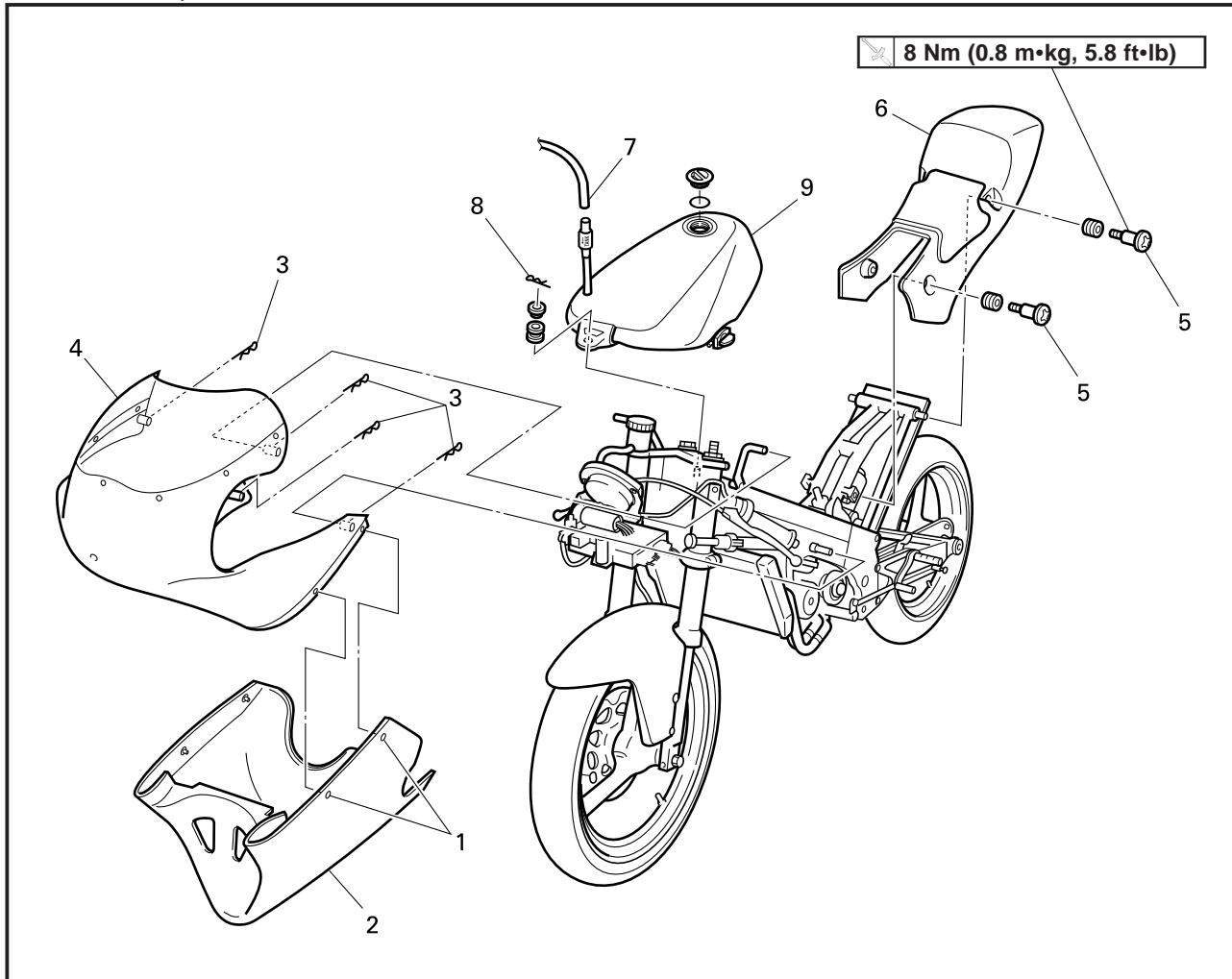

Extend of removal: ① Cowling removal ② Seat removal
 ③ Fuel tank removal

Extend of removal	Order	Part name	Q'ty	Remarks
		COWLING, SEAT AND FUEL TANK REMOVAL		
Preparation for removal		Turn the fuel cock to "OFF". Disconnect the fuel hose.		
① ↑ ↓ ② ↑ ↓ ③ ↑ ↓	1	Quick fastener	4	Refer to "REMOVAL POINTS".
	2	Lower cowl	1	
	3	Clip (upper cowl)	4	
	4	Upper cowl	1	
	5	Screw (seat)	4	
	6	Seat	1	
	7	Fuel tank breather hose	1	
	8	Clip (fuel tank)	1	
	9	Fuel tank	1	

4

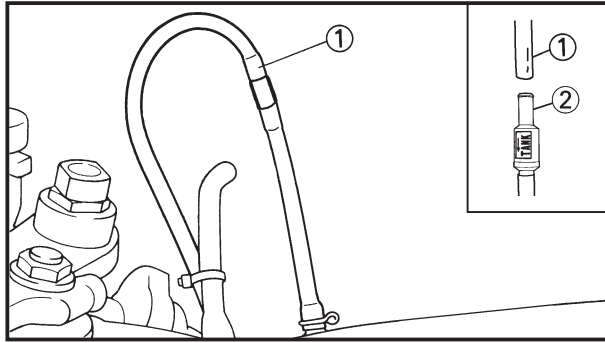

EC4U3000

REMOVAL POINTS

EC4U3100

Fuel tank breather hose

1. Disconnect:
 - Fuel tank breather hose ①

NOTE:

Disconnect the fuel tank breather hose with the valve joint ② remaining on the fuel tank side so as to prevent fuel from spurting out by the tank inner pressure.



EC4S0000

EXHAUST PIPE AND SILENCER

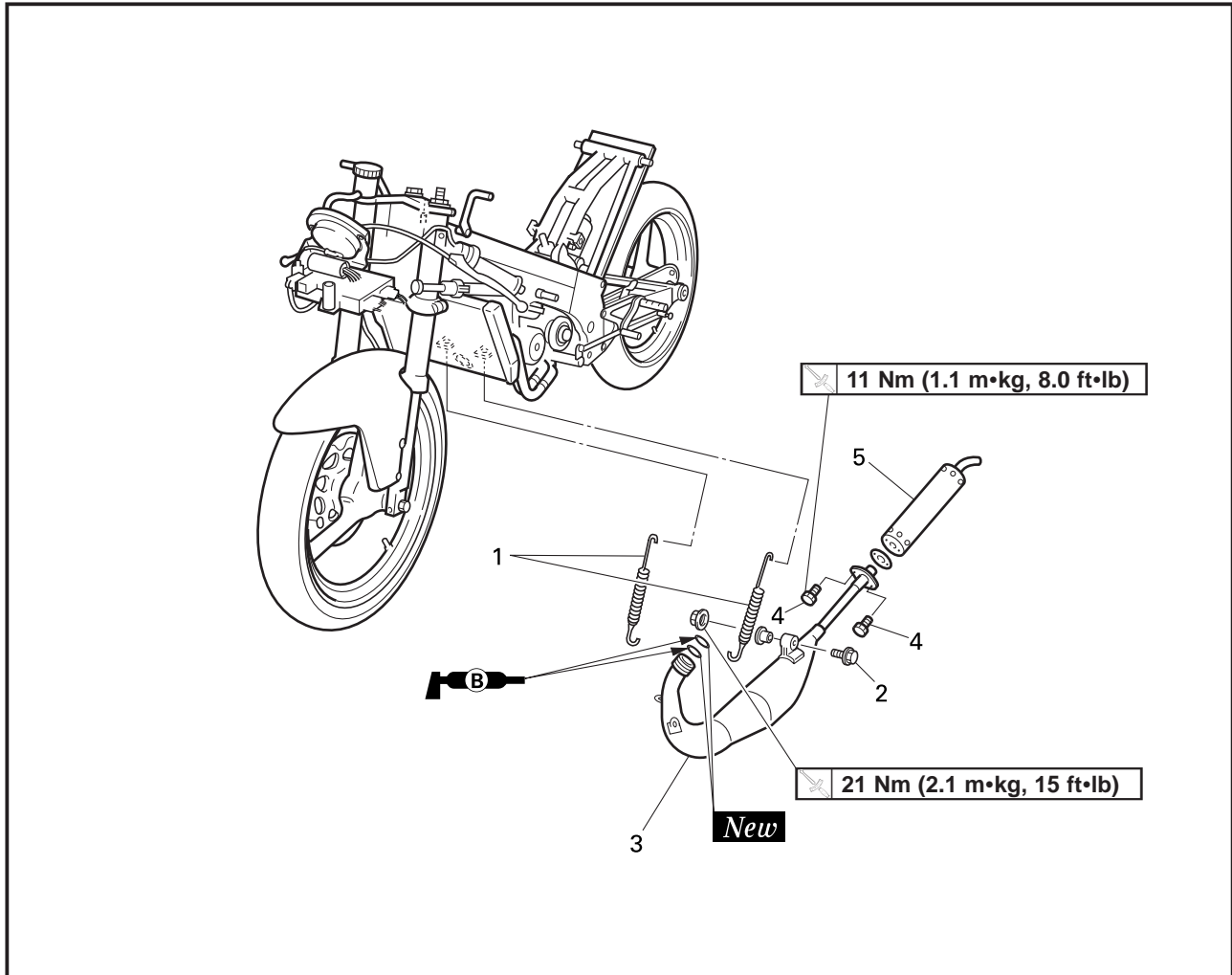

Extend of removal: ① Exhaust pipe removal ② Silencer removal

Extend of removal	Order	Part name	Q'ty	Remarks
Preparation for removal		EXHAUST PIPE AND SILENCER REMOVAL Lower cowl		Refer to "COWLING, SEAT AND FUEL TANK" section.
↑ ① ↓	1	Tension spring	2	
	2	Bolt (exhaust pipe)	1	
	3	Exhaust pipe	1	
	4	Bolt (silencer)	2	
↑ ② ↓	5	Silencer	1	



EC450001

RADIATOR

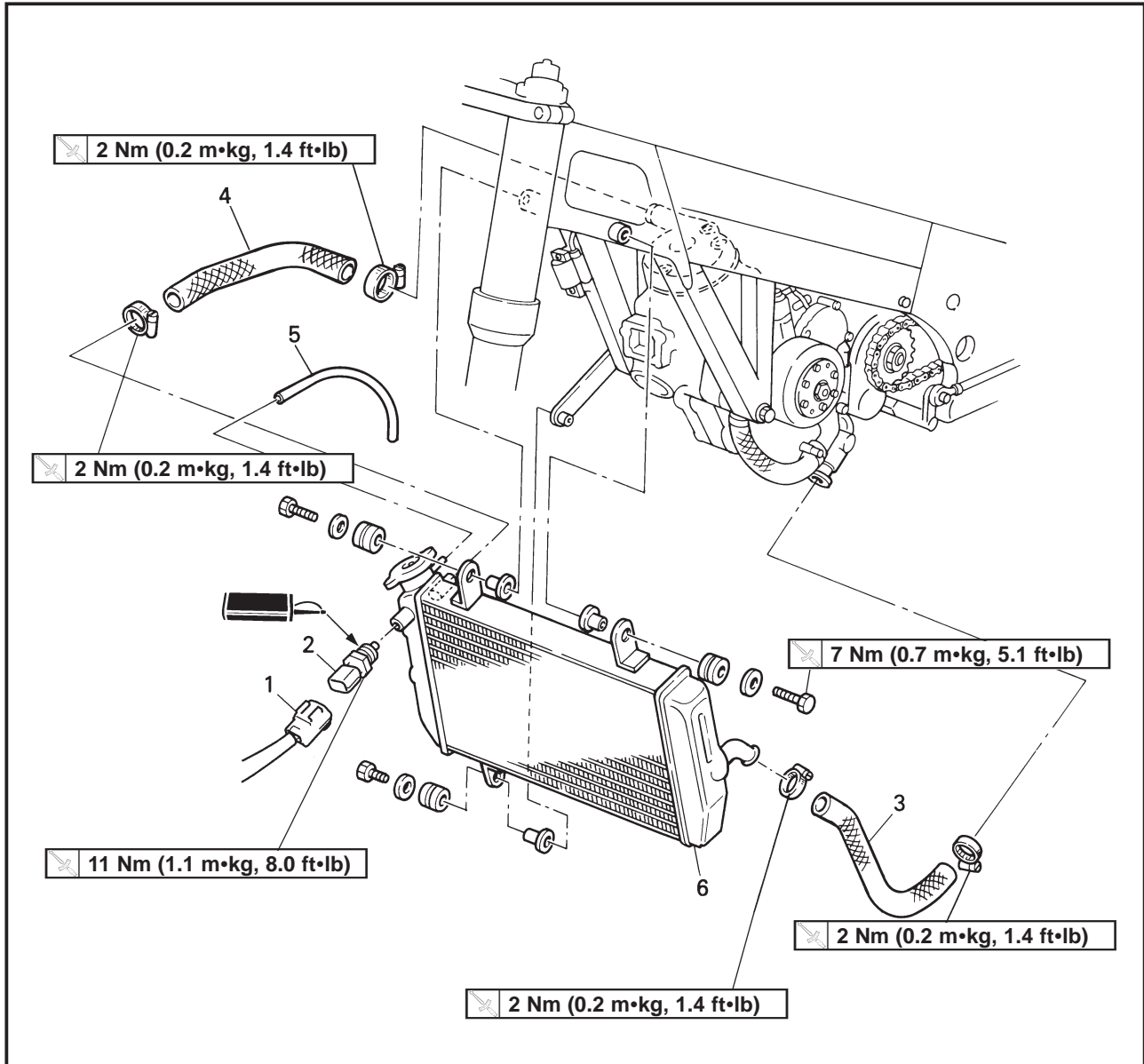

Extend of removal: ① Radiator removal

Extend of removal	Order	Part name	Q'ty	Remarks
Preparation for removal		RADIATOR REMOVAL		Refer to "COWLING, SEAT AND FUEL TANK" section. Refer to "COOLANT REPLACEMENT" section in the CHAPTER 3. Refer to "STEERING" section in the CHAPTER 5.
		Cowling and fuel tank		
		Drain the cooling water.		
		Steering damper		
①	1	Water temperature gauge lead	1	
	2	Thermo unit	1	
	3	Radiator hose 2	1	
	4	Radiator hose 4	1	
	5	Radiator breather hose	1	
	6	Radiator	1	



EC456000

HANDLING NOTE**⚠WARNING**

Do not remove the radiator cap when the engine and radiator are hot. Scalding hot fluid and steam may be blown out under pressure, which could cause serious injury. When the engine has cooled, open the radiator cap by the following procedure:

Place a thick rag, like a towel, over the radiator cap, slowly rotate the cap counterclockwise to the detent. This procedure allows any residual pressure to escape. When the hissing sound has stopped, press down on the cap while turning counterclockwise and remove it.

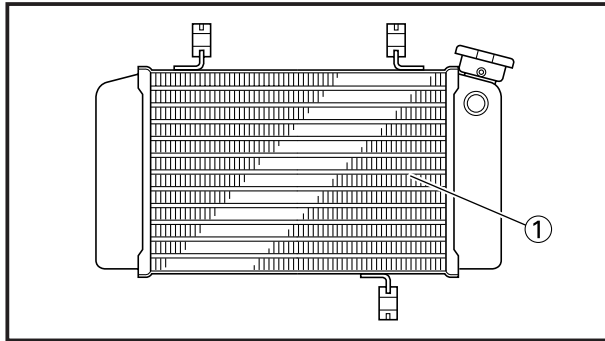

EC454000

INSPECTION

EC444100

Radiator

1. Inspect:

- Radiator core ①

Obstruction → Blow out with compressed air through rear of the radiator.

Bent fin → Repair/replace.

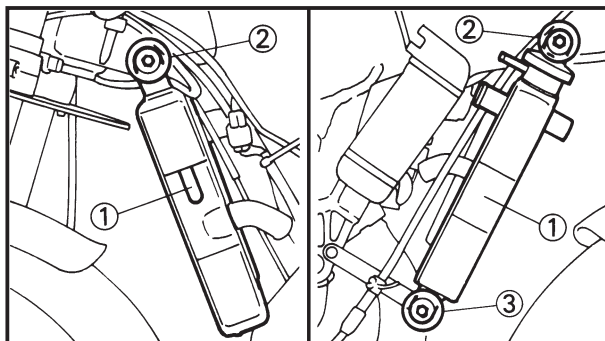

EC455000

ASSEMBLY AND INSTALLATION

EC455130

Radiator

1. Install:

- Radiator ①
- Bolt {radiator [$l=30$ mm (1.18 in)]} ②



 7 Nm (0.7 m•kg, 5.1 ft•lb)

- Bolt {radiator [$l=25$ mm (0.98 in)]} ③

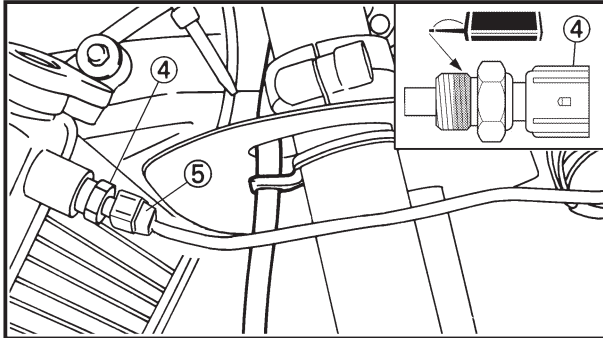
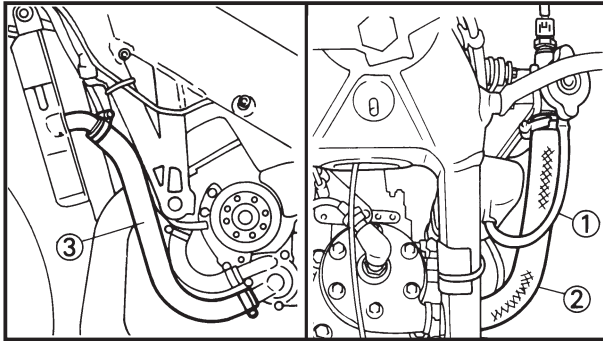
 7 Nm (0.7 m•kg, 5.1 ft•lb)



2. Install:

- Radiator breather hose ①
- Radiator hose 4 ②
 -  **2 Nm (0.2 m•kg, 1.4 ft•lb)**
- Radiator hose 2 ③
 -  **2 Nm (0.2 m•kg, 1.4 ft•lb)**
- Thermo unit ④
 -  **11 Nm (1.1 m•kg, 8.0 ft•lb)**
- Water temperature gauge lead ⑤

NOTE:

- Insert the end of the radiator breather hose into the catch tank. Refer to “CONTROL FUNCTION” section in the CHAPTER 1.
- Before applying LOCTITE®, wipe off dirt on the thread of the thermo unit and its receptacle on the radiator.
- Apply LOCTITE® to half of the thermo unit thread portion on the coupler side so as to prevent LOCTITE® from protruding into the radiator.



EC460000

CARBURETOR AND REED VALVE

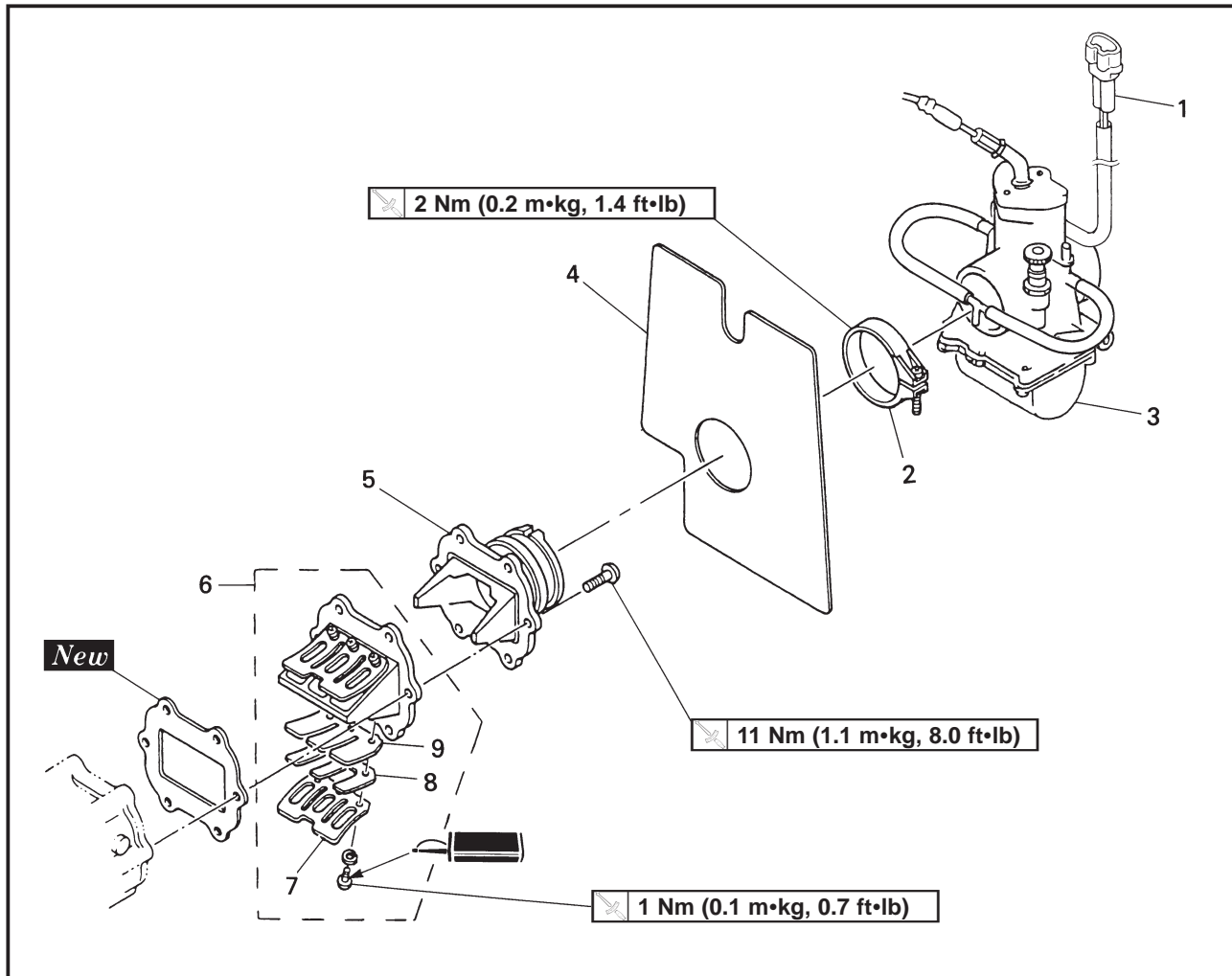

Extend of removal: ① Carburetor removal ② Reed valve removal

Extend of removal	Order	Part name	Q'ty	Remarks
Preparation for removal		CARBURETOR AND REED VALVE REMOVAL Cowling and fuel tank		Refer to "COWLING, SEAT AND FUEL TANK" section.
<div style="display: flex; align-items: center;"> <div style="margin-right: 20px;"> ↑ ① ↓ </div> <div style="margin-right: 20px;"> ↑ ② ↓ </div> </div>	1	Solenoid valve lead	1	Disconnect the solenoid valve lead. Loosen the screw (carburetor joint).
	2	Clamp (carburetor joint)	1	
	3	Carburetor	1	
	4	Carburetor cover	1	
	5	Carburetor joint	1	
	6	Reed valve assembly	1	
	7	Stopper (reed valve)	2	
	8	Reed valve 2	2	
	9	Reed valve 1	2	



EC468000

CARBURETOR DISASSEMBLY

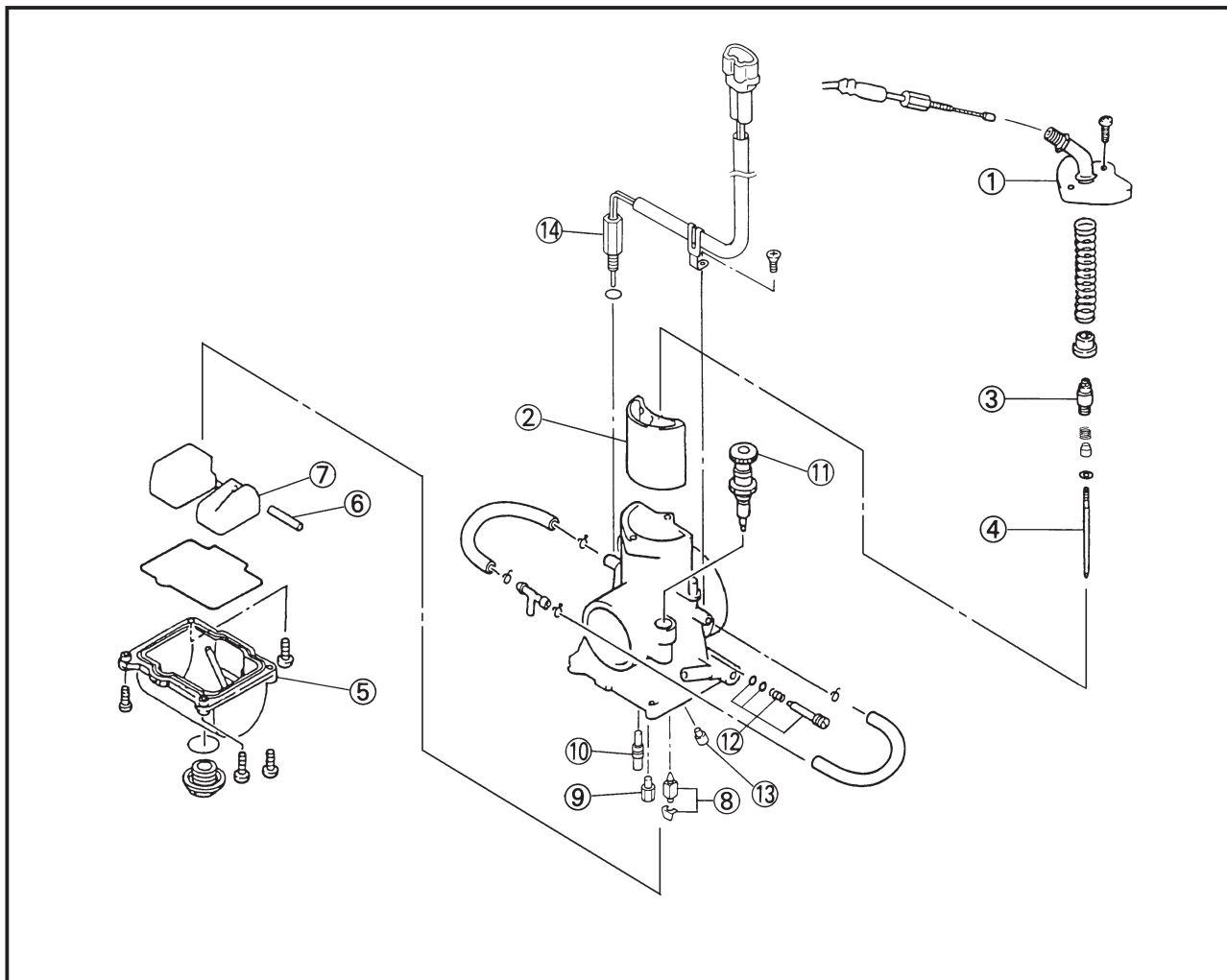

Extend of removal: ① Carburetor disassembly

Extend of removal	Order	Part name	Q'ty	Remarks
	CARBURETOR DISASSEMBLY			
	①	Mixing chamber top	1	Refer to "REMOVAL POINTS".
	②	Throttle valve	1	
	③	Needle holder	1	
	④	Jet needle	1	
	⑤	Float chamber	1	
	⑥	Float pin	1	
	⑦	Float	1	
	⑧	Needle valve	1	Refer to "REMOVAL POINTS".
	⑨	Main jet	1	
	⑩	Pilot jet	1	
	⑪	Starter plunger	1	
	⑫	Pilot air screw	1	
	⑬	Power jet	1	
⑭	Solenoid valve	1		

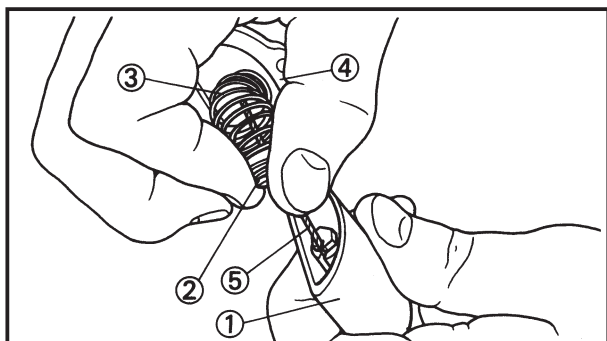

EC463000

REMOVAL POINTS

EC463110

Throttle valve

1. Remove:
 - Throttle valve ①
 - Ring ②
 - Spring (throttle valve) ③
 - Mixing chamber top ④
 - Throttle cable ⑤

NOTE:

While compressing the spring (throttle valve), disconnect the throttle cable.

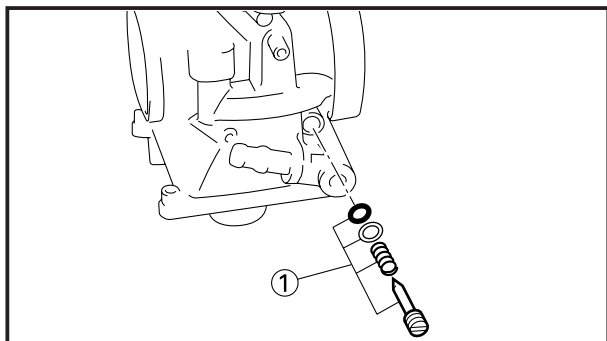

EC463401

Pilot air screw

1. Remove:
 - Pilot air screw ①

NOTE:

To optimize the fuel flow at a smaller throttle opening, each machine's pilot air screw has been individually set at the factory. Before removing the pilot air screw, turn it in fully and count the number of turns. Record this number as the factory-set number of turns out.



EC464000

INSPECTION

EC464130

Carburetor

1. Inspect:
 - Carburetor body
Contamination → Clean.

NOTE:

- Use a petroleum based solvent for cleaning. Blow out all passages and jets with compressed air.
- Never use a wire.

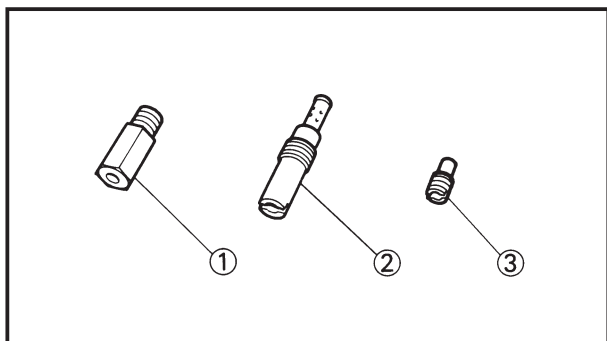

2. Inspect:
 - Main jet ①
 - Pilot jet ②
 - Power jet ③
 Contamination → Clean.

NOTE:

- Use a petroleum based solvent for cleaning. Blow out all passages and jets with compressed air.
- Never use a wire.

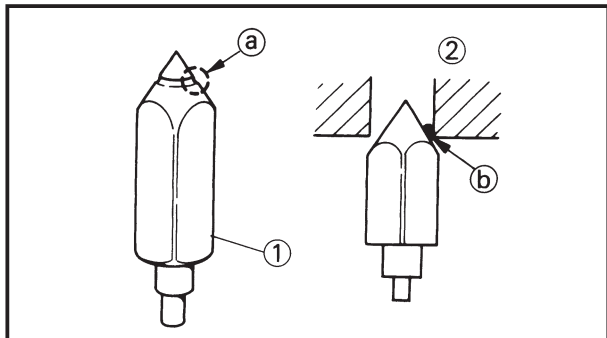

EC464210

Needle valve

1. Inspect:
 - Needle valve ①
 - Valve seat ②
 Grooved wear (a) → Replace.
 Dust (b) → Clean.

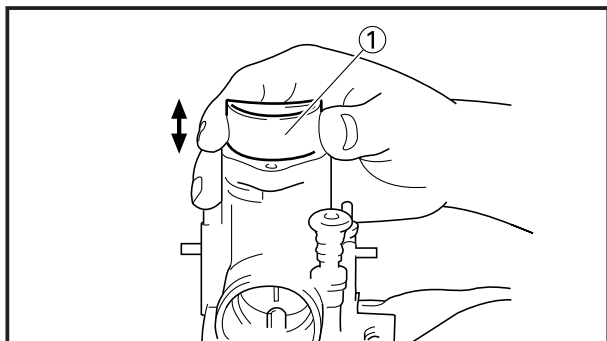

EC464301

Throttle valve

1. Check:
 - Free movement
 Stick → Repair or replace.

NOTE:

Insert the throttle valve ① into the carburetor body, and check for free movement.

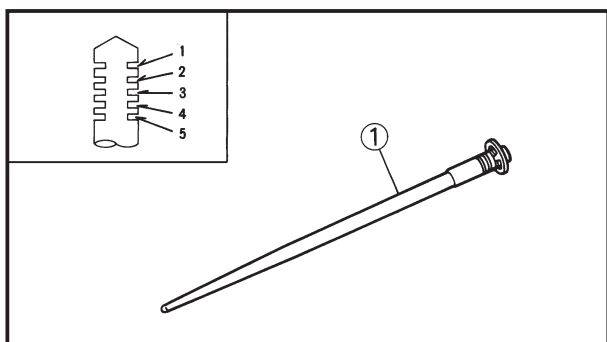

EC464410

Jet needle

1. Inspect:
 - Jet needle ①
 Bends/Wear → Replace.
 - Clip groove
 Free play exists/Wear → Replace.
 - Clip position



**Factory-set clip position:
No.3 Groove**

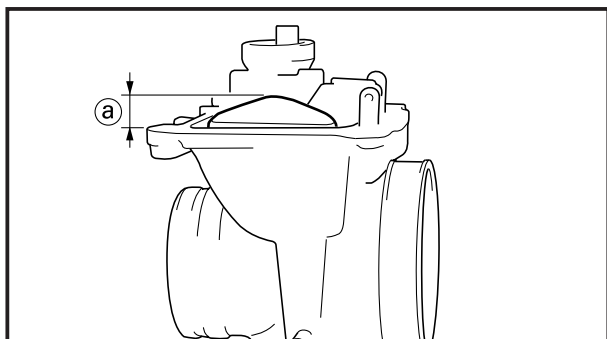

EC464511

Float height

1. Measure:
 - Float height (a)
 Out of specification → Adjust.



**Float height:
5.5~7.5 mm (0.22~0.30 in)**

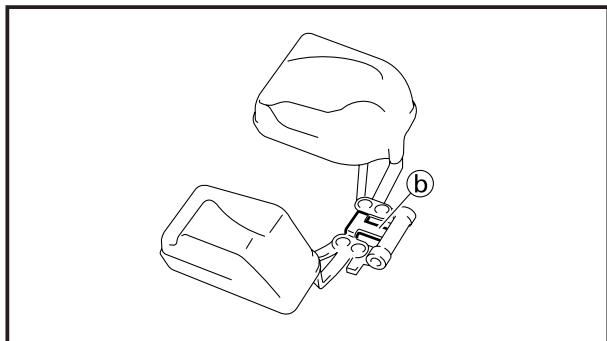

Measurement and adjustment steps:

- Hold the carburetor in an upside down position.
- Measure the distance between the mating surface of the float chamber and top of the float using a vernier calipers.

NOTE:

The float arm should be resting on the needle valve, but not compressing the needle valve.

- If the float height is not within specification, inspect the valve seat and needle valve.
- If either is worn, replace them both.
- If both are fine, adjust the float height by bending the float tab (b) on the float.
- Recheck the float height.

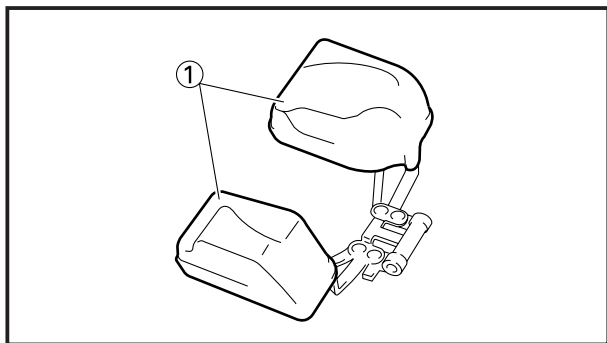

EC464600

Float

1. Inspect:
 - Float ①
 Damage → Replace.

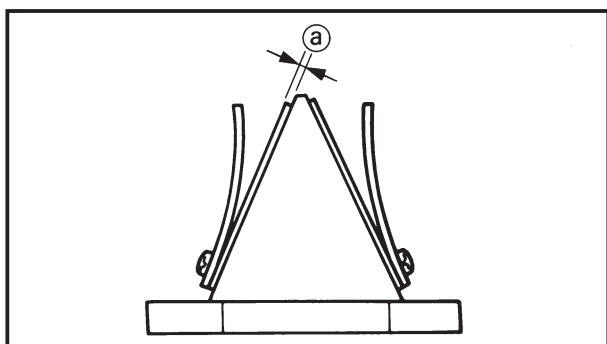

EC464701

Reed valve

1. Measure:
 - Reed valve bending (a)
 Out of specification → Replace.



Reed valve bending limit:
0.2 mm (0.008 in)

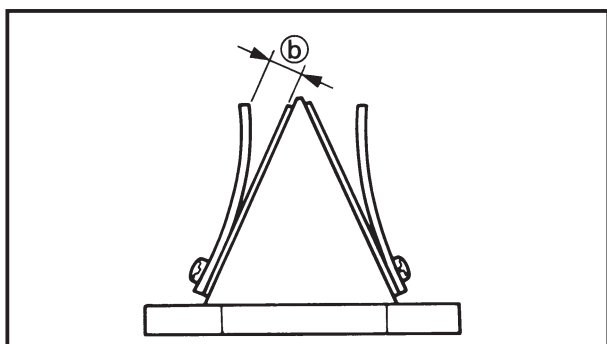

- Valve stopper height (b)
- Out of specification → Adjust stopper/Replace valve stopper.



Valve stopper height:
10.6~11.0 mm (0.417~0.433 in)

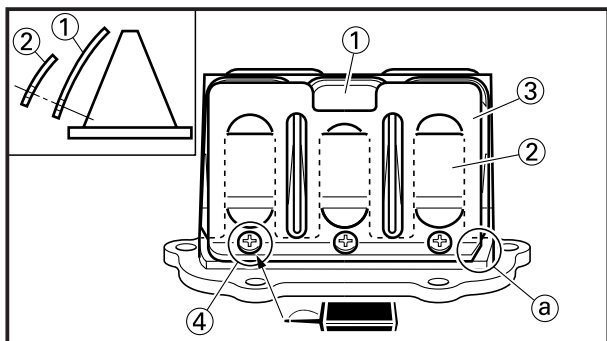

EC465000

ASSEMBLY AND INSTALLATION

EC465140

Reed valve

1. Install:
 - Reed valve 1 ①
 - Reed valve 2 ②
 - Stopper (reed valve) ③
 - Screw (reed valve) ④

1 Nm (0.1 m•kg, 0.7 ft•lb)

NOTE:

- Install the reed valve with the reed valve bending as shown.
- Note the cut ① in the lower corner of the reed and stopper plate.

CAUTION:

Tighten each screw gradually to avoid warping.

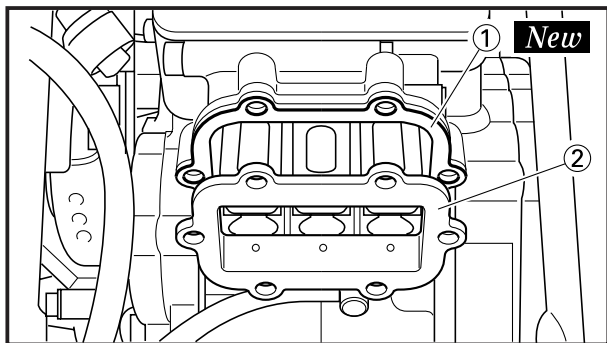

2. Install:

- Gasket (reed valve assembly) ① **New**
- Reed valve assembly ②

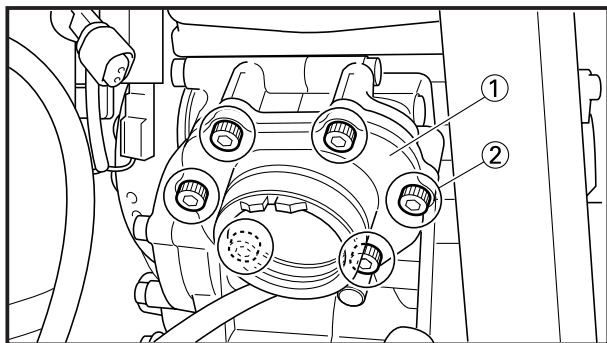

3. Install:

- Carburetor joint ①
- Bolt (carburetor joint) ②

11 Nm (1.1 m•kg, 8.0 ft•lb)

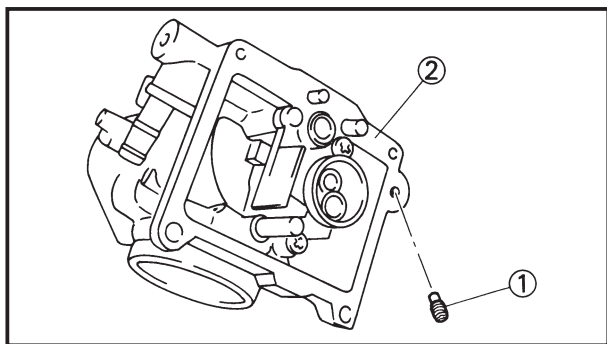

EC4652A1

Carburetor

1. Install:
 - Power jet ①
 - To carburetor ②.

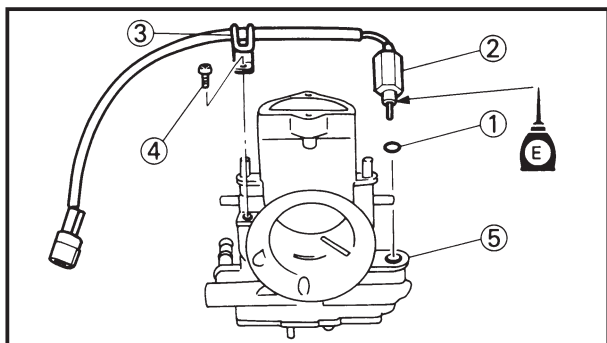

2. Install:
- O-ring ①
 - Solenoid valve ②
 - Clamp ③
 - Screw (clamp) ④
To carburetor ⑤.

CAUTION:

- Before installing the solenoid valve, blow air on the solenoid valve and its installing location on the carburetor in order to remove any foreign particles such as chips etc.
- Apply the engine oil on the solenoid valve thread.

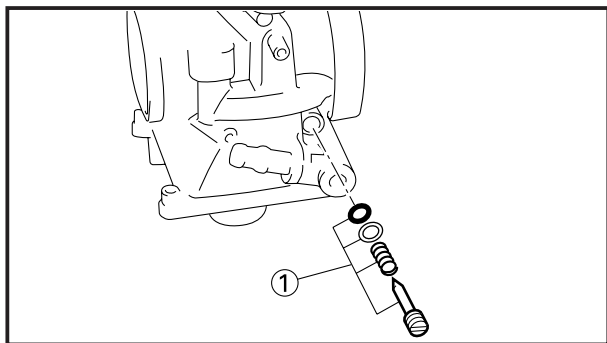

3. Install:
- Pilot air screw ①

Note the following installation points:

- Turn in the pilot air screw until it is lightly seated.
- Turn out the pilot air screw by the number of turns recorded before removing.



Pilot air screw:
Factory-set number of turns out

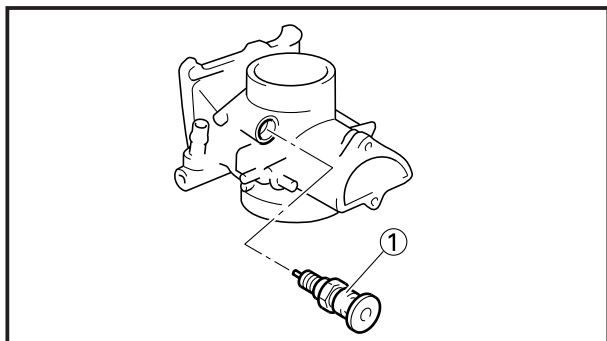

4. Install:
- Starter plunger ①

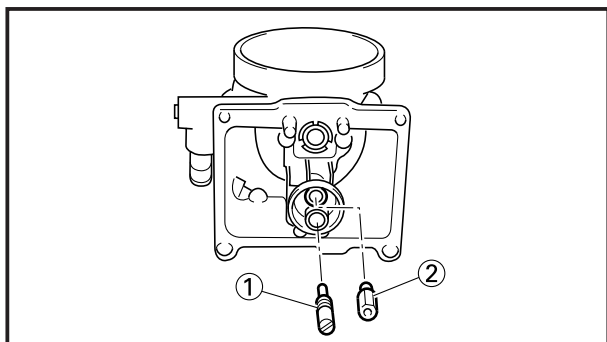

5. Install:
- Pilot jet ①
 - Main jet ②

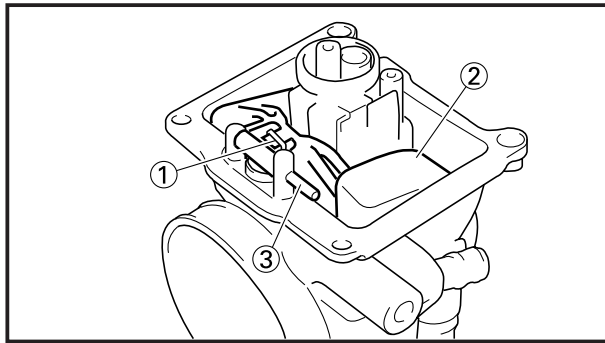

6. Install:
- Needle valve ①
 - Float ②
 - Float pin ③

NOTE:

- After installing the needle valve to the float, install them to the carburetor.
- Check the float for smooth movement.

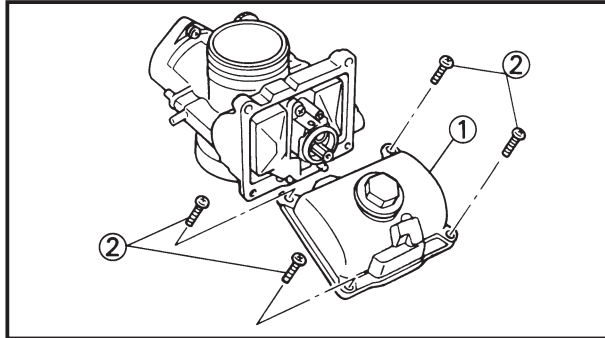

7. Install:
- Float chamber ①
 - Screw (float chamber) ②

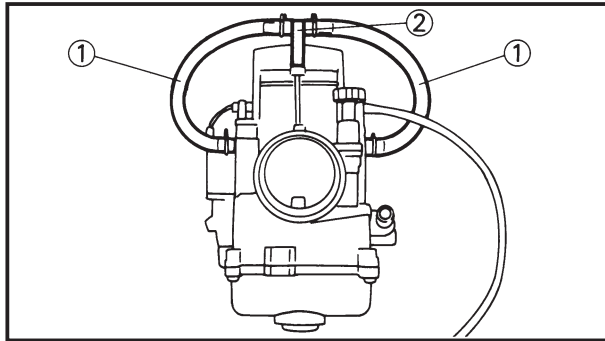

8. Install:
- Air vent hose ①
 - Joint ②

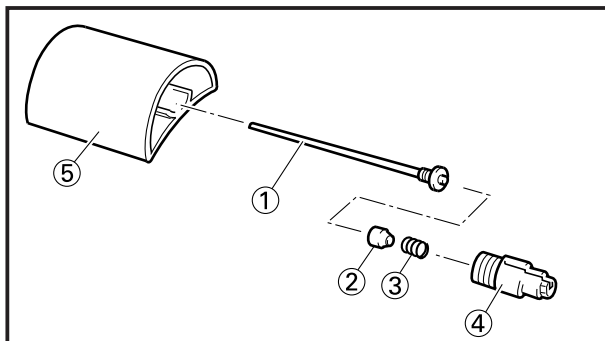

9. Install:
- Jet needle ①
 - Collar ②
 - Spring ③
 - Needle holder ④
- To throttle valve ⑤.

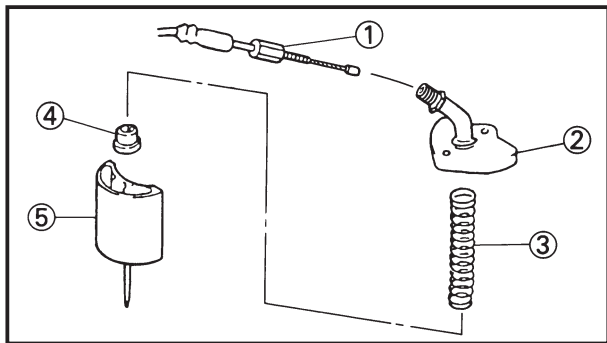

10. Install:

- Throttle cable ①
- Mixing chamber top ②
- Spring (throttle valve) ③
- Ring ④
- Throttle valve ⑤

NOTE:

- While compressing the spring, connect the throttle cable.
- Align the projection (a) on the ring with the groove (b) in the needle holder ⑥.

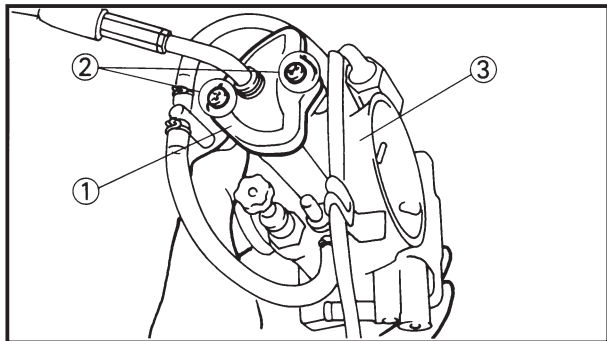
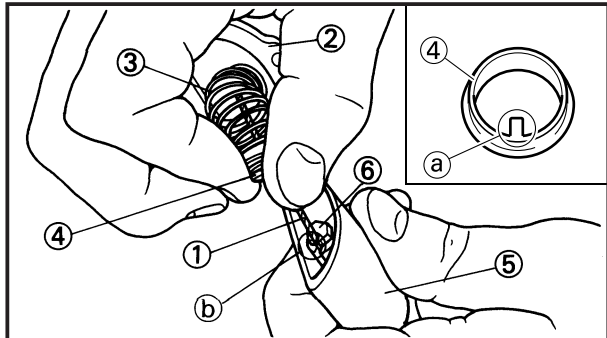

11. Install:

- Mixing chamber top ①
- Screw (mixing chamber top) ②
To carburetor ③.

NOTE:

After installing, check the throttle grip for smooth movement.

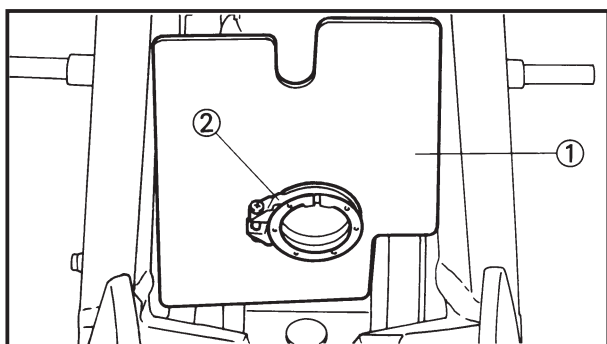

EC465310

Carburetor installation

1. Install:

- Carburetor cover ①
- Clamp (carburetor joint) ②

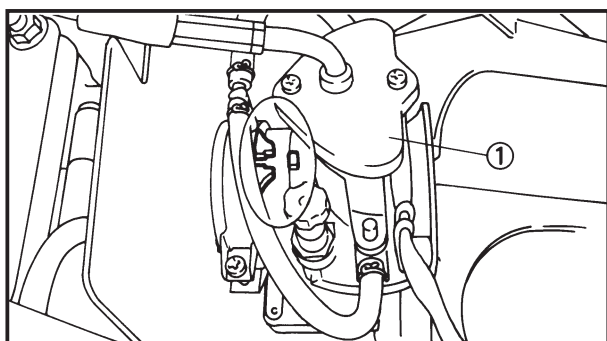

2. Install:

- Carburetor ①

NOTE:

Install the projection between the carburetor joint slots.

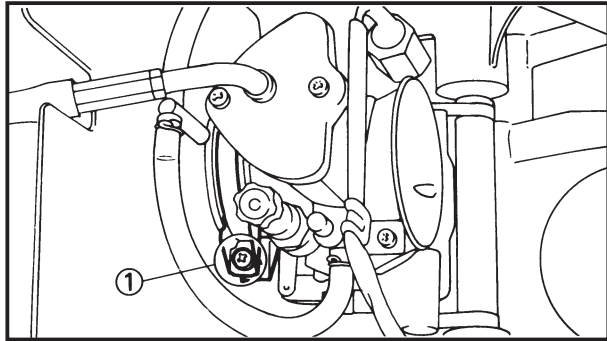

3. Tighten:

- Clamp (carburetor joint) ①

 2 Nm (0.2 m•kg, 1.4 ft•lb)

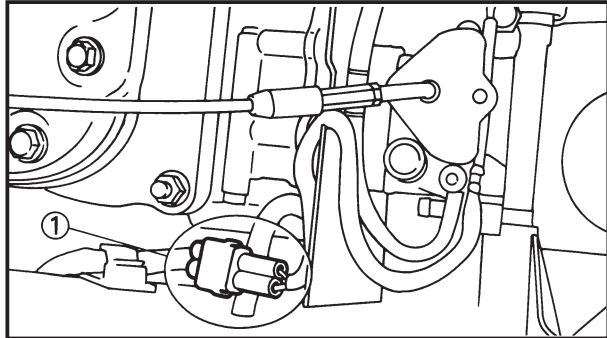

4. Connect:

- Solenoid valve lead ①

Refer to “CABLE ROUTING DIAGRAM”
section in the CHAPTER 2.



EC470000

CYLINDER HEAD, CYLINDER AND PISTON



EC478000

CYLINDER HEAD AND CYLINDER

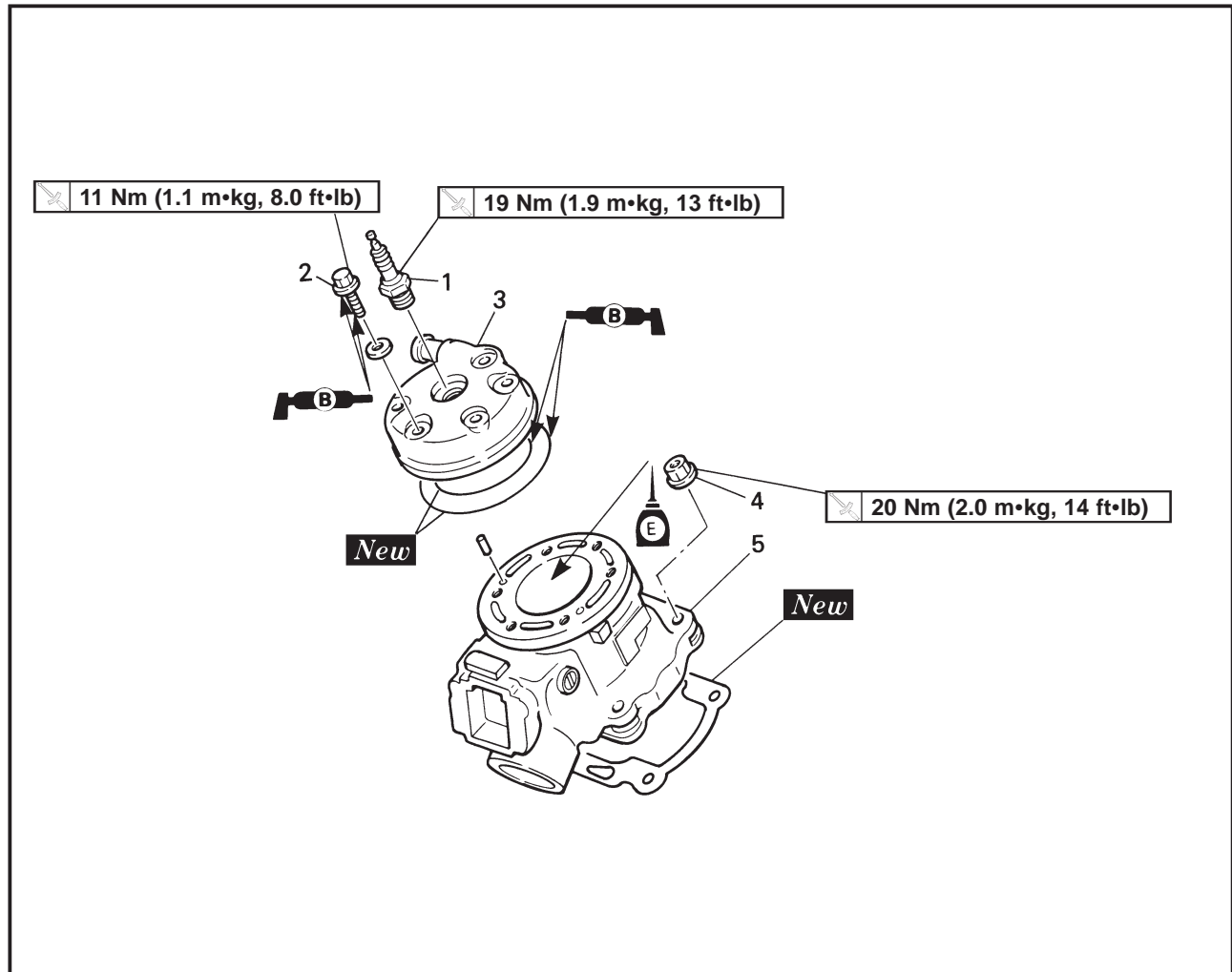

Extend of removal: ① Cylinder head removal ② Cylinder removal

Extend of removal	Order	Part name	Q'ty	Remarks	
Preparation for removal		CYLINDER HEAD AND CYLINDER REMOVAL Cowling and fuel tank Exhaust pipe Radiator hose 4 Bolt (radiator)		Refer to "COWLING, SEAT AND FUEL TANK" section. Refer to "EXHAUST PIPE AND SILENCER" section. Disconnect at cylinder head side. Shift the radiator forward.	
	<div style="display: flex; align-items: center; gap: 20px;"> <div style="text-align: center;"> ↑ ① ↓ </div> <div style="text-align: center;"> ↑ ② ↓ </div> </div>	1	Spark plug	1	Loosen each bolt 1/4 turn, and remove them after all bolts are loosened.
		2	Bolt (cylinder head)	6	
3	Cylinder head	1			
4	Nut (cylinder)	4			
5	Cylinder	1			



EC478200
PISTON



Extend of removal: ① Piston and piston ring removal

Extend of removal	Order	Part name	Q'ty	Remarks
↑ ① ↓	PISTON REMOVAL			
	1	Piston pin clip	2	} Refer to "REMOVAL POINTS".
	2	Piston pin	1	
	3	Piston	1	
	4	Small end bearing	1	
5	Piston ring	1		

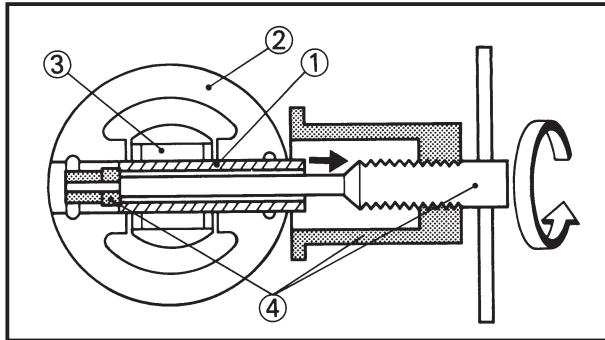
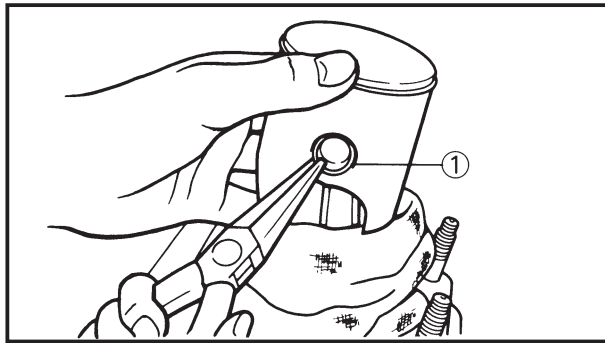

EC473000

REMOVAL POINTS

EC473400

Piston and piston ring

- Remove:
 - Piston pin clip ①

NOTE:

Before removing the piston pin clip, cover the crankcase with a clean rag to prevent the piston pin clip from falling into the crankcase cavity.

- Remove:
 - Piston pin ①
 - Piston ②
 - Small end bearing ③

NOTE:

Before removing the piston pin, deburr the clip groove and pin hole area. If the piston pin groove is deburred and piston pin is still difficult to remove, use the piston pin puller ④.



Piston pin puller:

YU-01304/90890-01304

CAUTION:

Do not use a hammer to drive the piston pin out.

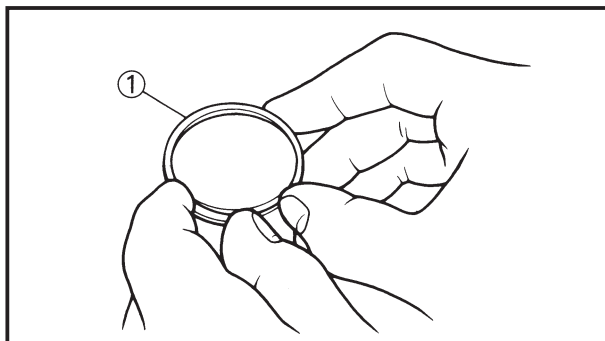

- Remove:
 - Piston ring ①

NOTE:

Take care not to scratch the piston and damage the piston ring.

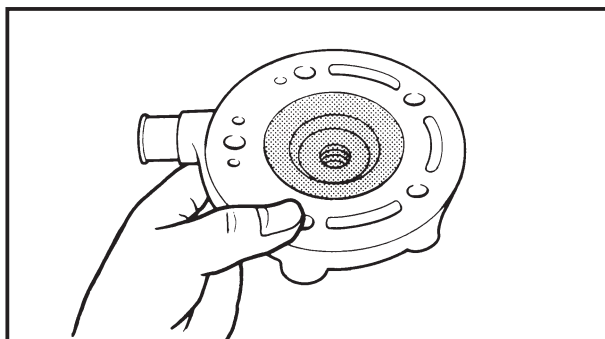

EC474000

INSPECTION

EC474110

Cylinder head

- Remove:
 - Carbon deposits

Use #400~600 grit wet sandpaper.

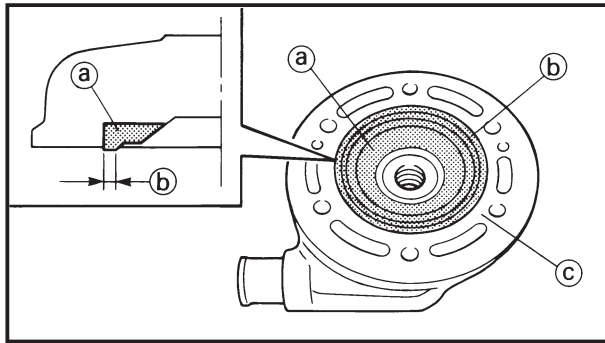

2. Inspect:

- Cylinder head water jacket
Crust of minerals/Rust → Remove.
- Cylinder head contact surface
Wear/Damage → Replace.
- Recess of insert portion (a)
The contact surface (b) of the insert portion is recessed below the aluminum portion (c) → Replace.

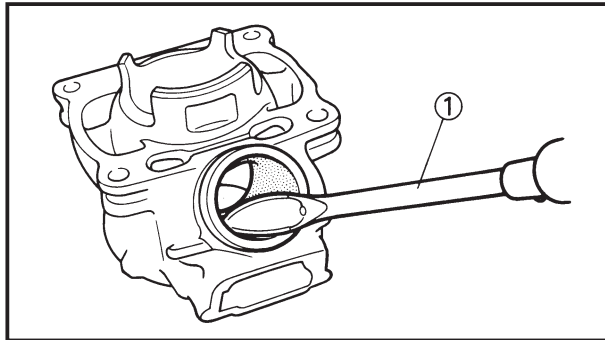

EC474210

Cylinder

1. Remove:

- Carbon deposits
Use a rounded scraper (1).

NOTE:

Do not use a sharp instrument. Avoid scratching the aluminum.

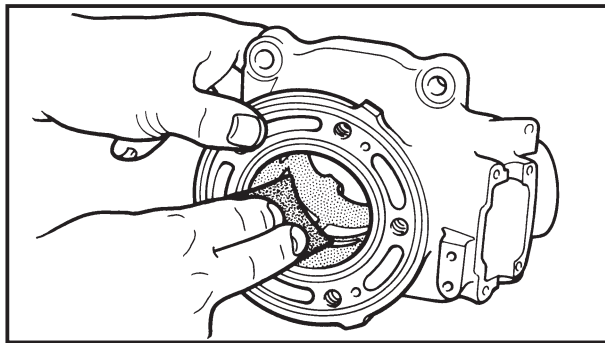

2. Inspect:

- Cylinder inner surface
Score marks → Repair or replace.
Use #400~600 grit wet sandpaper.

CAUTION:

Do not rebores the cylinder.

3. Inspect:

- Travel distance for cylinder
3,000 km (1,800 miles) or more → Replace.

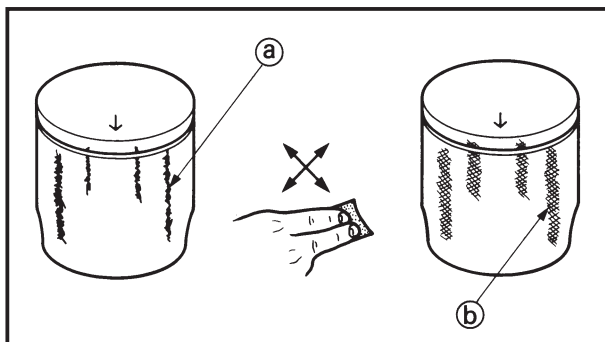

EC474313

Piston

1. Inspect:

- Piston crown
Damage and crack due to detonation → Replace.
- Piston pin hole
Crack → Replace.
- Contact with cylinder
Excessive scuffing, score (a) → Use #400~600 grit wet sandpaper in a criss-cross manner (b).
- Heat discoloration → Replace.



2. Inspect:
 - Travel distance for piston
500 km (300 miles) or more → Replace.

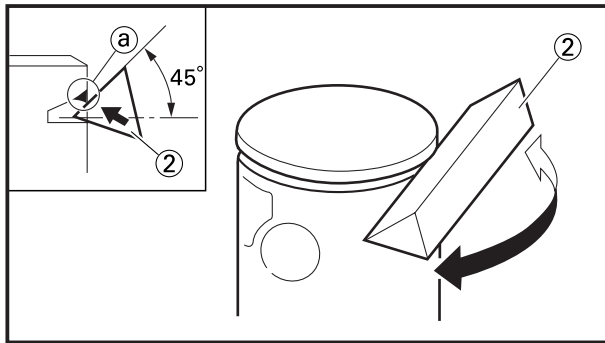
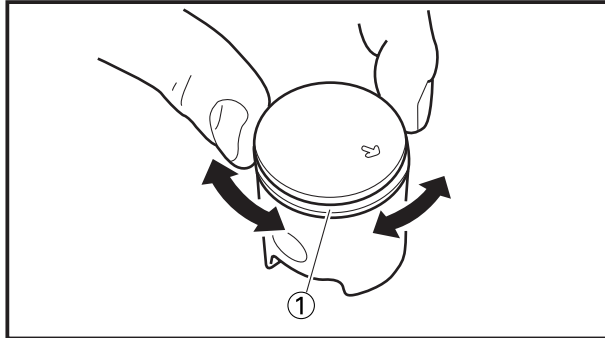

3. Check:
 - Piston ring free movement
Mechanical stick → Repair.
Install the piston ring ① to the piston, and check for free movement.

Repairing steps:

- Remove the piston ring.
- Chamfer the piston ring groove at its edge ① where the piston ring tends to stick, using a triangle oil stone ② with the engine mixing oil.

NOTE:

- Set the triangle oil stone to the piston ring groove to form an angle of 45°. Do the chamfering with force applied to this edge.
- Chamfer until the piston ring moves smoothly.

CAUTION:

Do not over-chamfer.

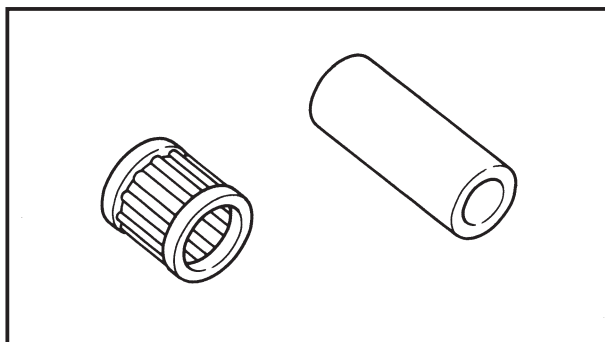

EC474402

Piston pin and small end bearing

1. Inspect:
 - Piston pin
 - Small end bearing
Signs of heat discoloration → Replace.

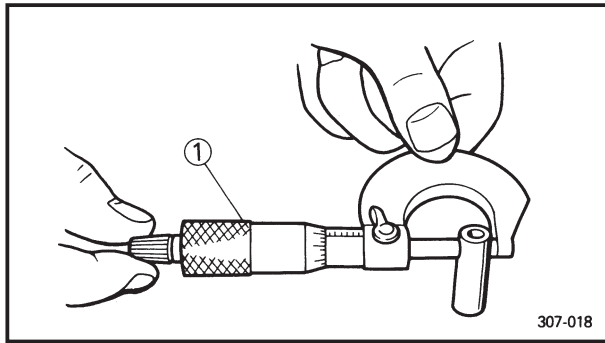

2. Measure:

- Piston pin outside diameter
Use micrometer ①.
Out of limit → Replace.

Piston pin outside diameter:	
Standard	Limit
14.995~15.000 mm (0.5904~0.5906 in)	14.975 mm (0.5896 in)

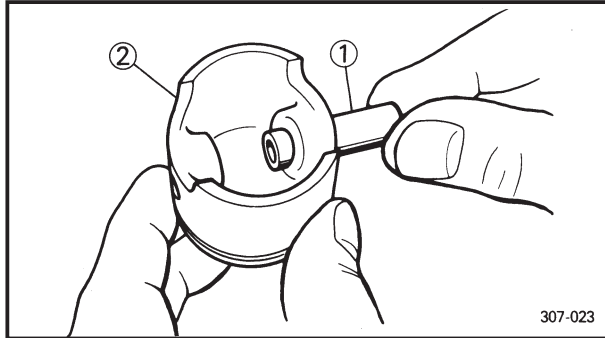

3. Check:

- Free play (when the piston pin ① is in place in the piston ②)
There should be no noticeable for the play.
Free play exists → Replace piston pin and/or piston.

4. Install:

- Small end bearing
- Piston pin
Into the small end of connecting rod.

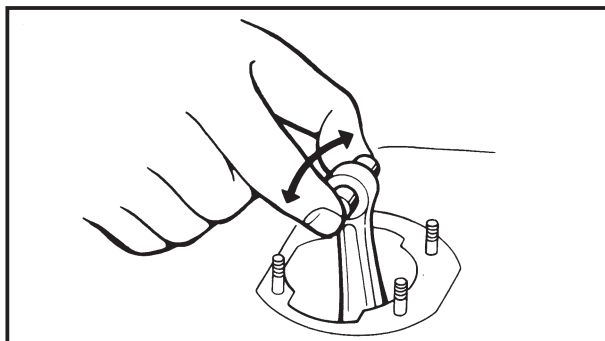

5. Check:

- Free play
There should be no noticeable free play.
Free play exists → Inspect the connecting rod for wear/Replace the pin and/or connecting rod as required.

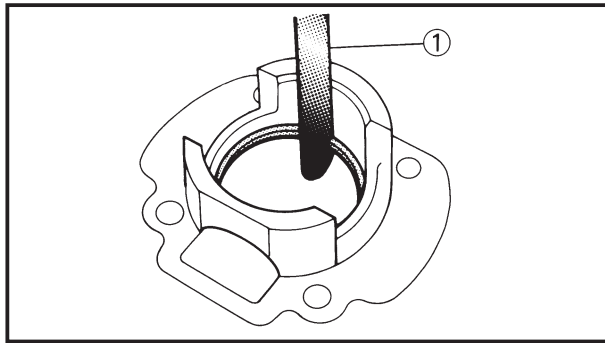

EC474520

Piston ring

1. Install:
 - Piston ring
Into the cylinder.
Push the ring with the piston crown.
2. Measure:
 - End gap
Use a thickness gauge (1).
Out of limit → Replace.



Ring end gap (installed):

Standard	<Limit>
0.22~0.37 mm (0.009~0.015 in)	0.59 mm (0.023 in)

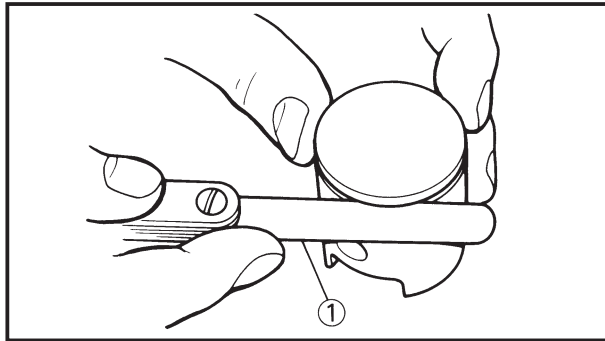

3. Measure:
 - Side clearance
Use a thickness gauge (1).
Out of limit → Replace piston and/or ring.



Side clearance:

Standard	<Limit>
0.02~0.06 mm (0.0008~0.0024 in)	0.1 mm (0.004 in)

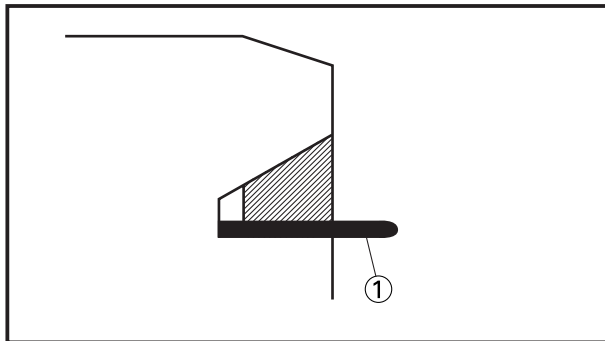

NOTE:

- Insert the thickness gauge deep in the piston ring groove. Then measure the clearance with both sliding surfaces being flush with each other.
- Check at several points.

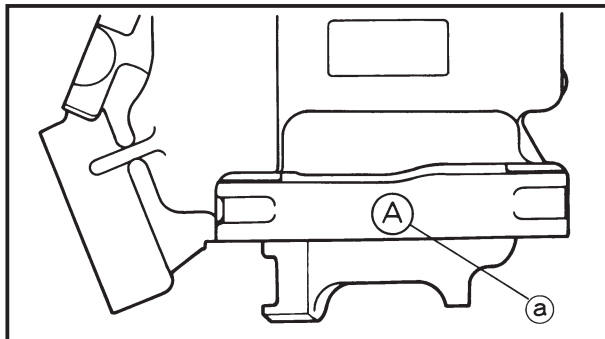

EC474720

Combination of piston and cylinder

1. Check:
 - Cylinder mark (a)

Cylinder mark (a)
A
B
C

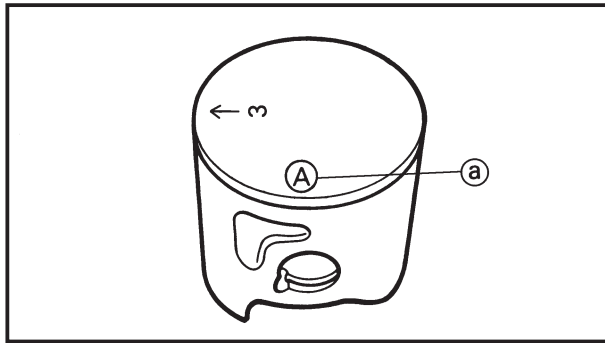

2. Check:

- Piston mark (a)

Piston mark (a) (color)
A (red)
B (orange)
C (green)

3. Combination:

Combine the piston and cylinder by the following chart.

Cylinder mark	Piston mark (color)
A	A (red)
B	B (orange)
C	C (green)

NOTE:

When you purchase a cylinder, you cannot designate a specific one. Choose the piston that matches the above chart.

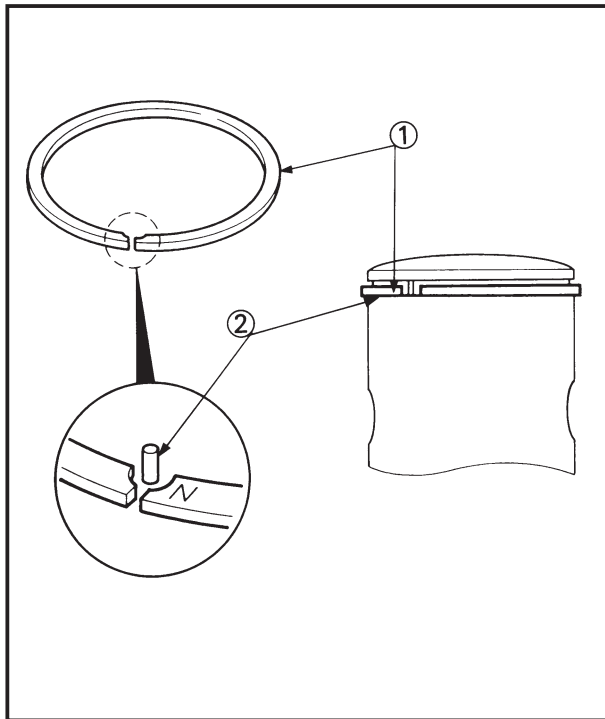

EC475000

ASSEMBLY AND INSTALLATION

EC475261

Piston ring and piston

1. Install:

- Piston ring (1)

NOTE:

- Take care not to scratch the piston or damage the piston ring.
- Install the piston ring with its mark "N" upward.
- Align the piston ring gap with the pin (2).
- After installing the piston ring, check the smooth movement of it.

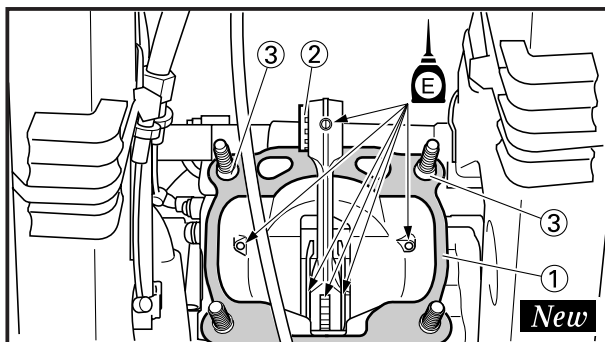

2. Install:

- Gasket (cylinder) (1) **New**
- Small end bearing (2)
- Dowel pin (3)

NOTE:

- Apply the engine oil on the bearing (crankshaft and connecting rod) and connecting rod big end washers.
- Install the gasket with the seal print side toward the crankcase.

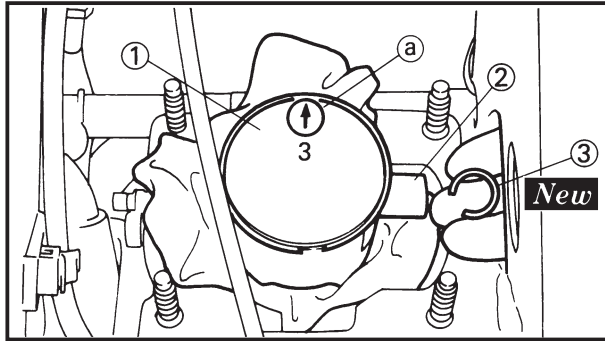

3. Install:
- Piston ①
 - Piston pin ②
 - Piston pin clip ③ **New**

NOTE: _____

- The arrow ① on the piston dome must point to exhaust side.
- Before installing the piston pin clip, cover the crankcase with a clean rag to prevent the piston pin clip from falling into the crankcase cavity.

CAUTION: _____

Do not allow the clip open ends to meet the piston pin slot ②.

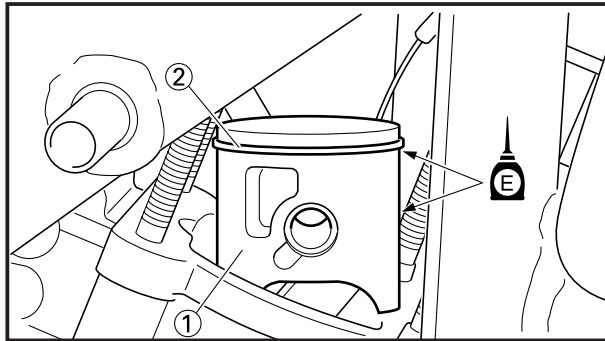
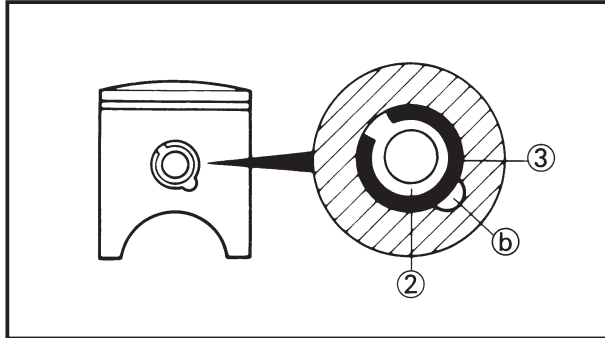

EC4753B1

Cylinder head and cylinder

1. Apply:
- Engine oil
To piston ①, piston ring ② and cylinder inner surface.

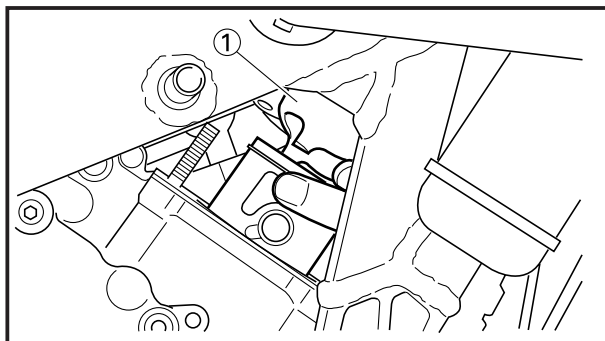

2. Install:
- Cylinder ①

CAUTION: _____

Make sure the piston ring is properly positioned. Install the cylinder with one hand while compressing the piston ring with the other hand.

NOTE: _____

After installing, check the smooth movement of the piston.

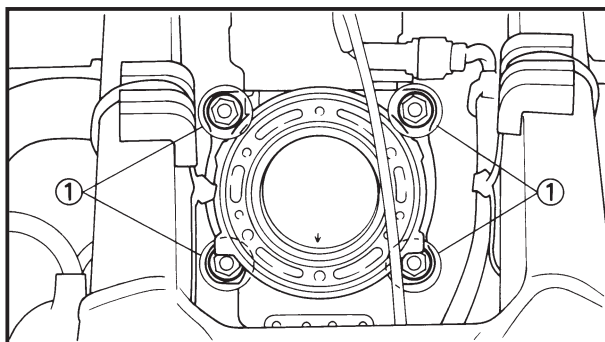

3. Install:
- Nut (cylinder) ①

20 Nm (2.0 m•kg, 14 ft•lb)

NOTE: _____

Tighten the nuts in stages, using a crisscross pattern.

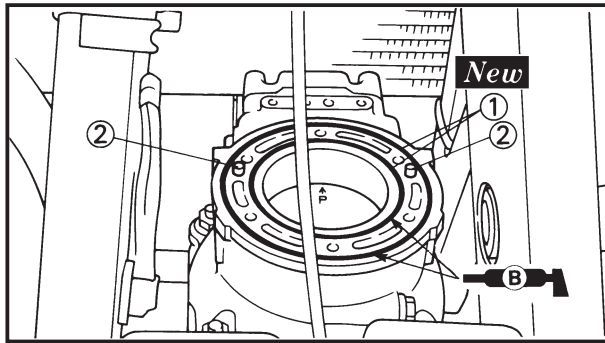

4. Install:
- O-ring ① **New**
 - Dowel pin ②

NOTE:

Apply the lithium soap base grease on the O-rings.

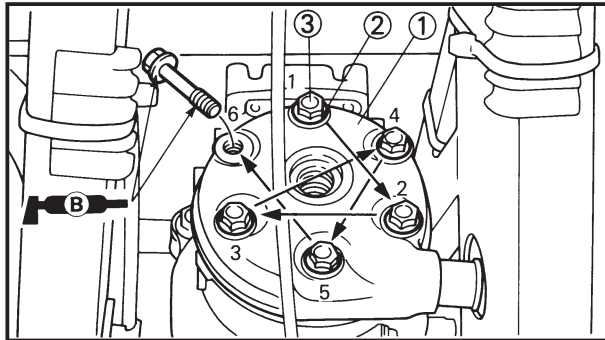

5. Install:
- Cylinder head ①
 - Copper washer ②
 - Bolt (cylinder head) ③

11 Nm (1.1 m•kg, 8.0 ft•lb)

NOTE:

- Apply the lithium soap base grease on the thread and contact surface of the bolt (cylinder head).
- Tighten the bolts (cylinder head) in stage, using a crisscross pattern.

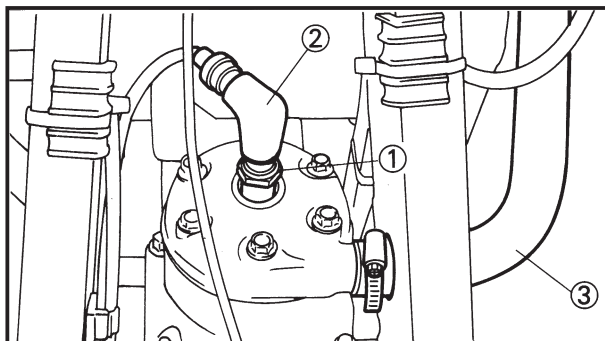

6. Install:
- Spark plug ①

19 Nm (1.9 m•kg, 13 ft•lb)

- Spark plug cap ②
- Radiator hose ④ ③

2 Nm (0.2 m•kg, 1.4 ft•lb)



EC4A0000

CLUTCH

EC4A8000

CLUTCH PLATE AND FRICTION PLATE

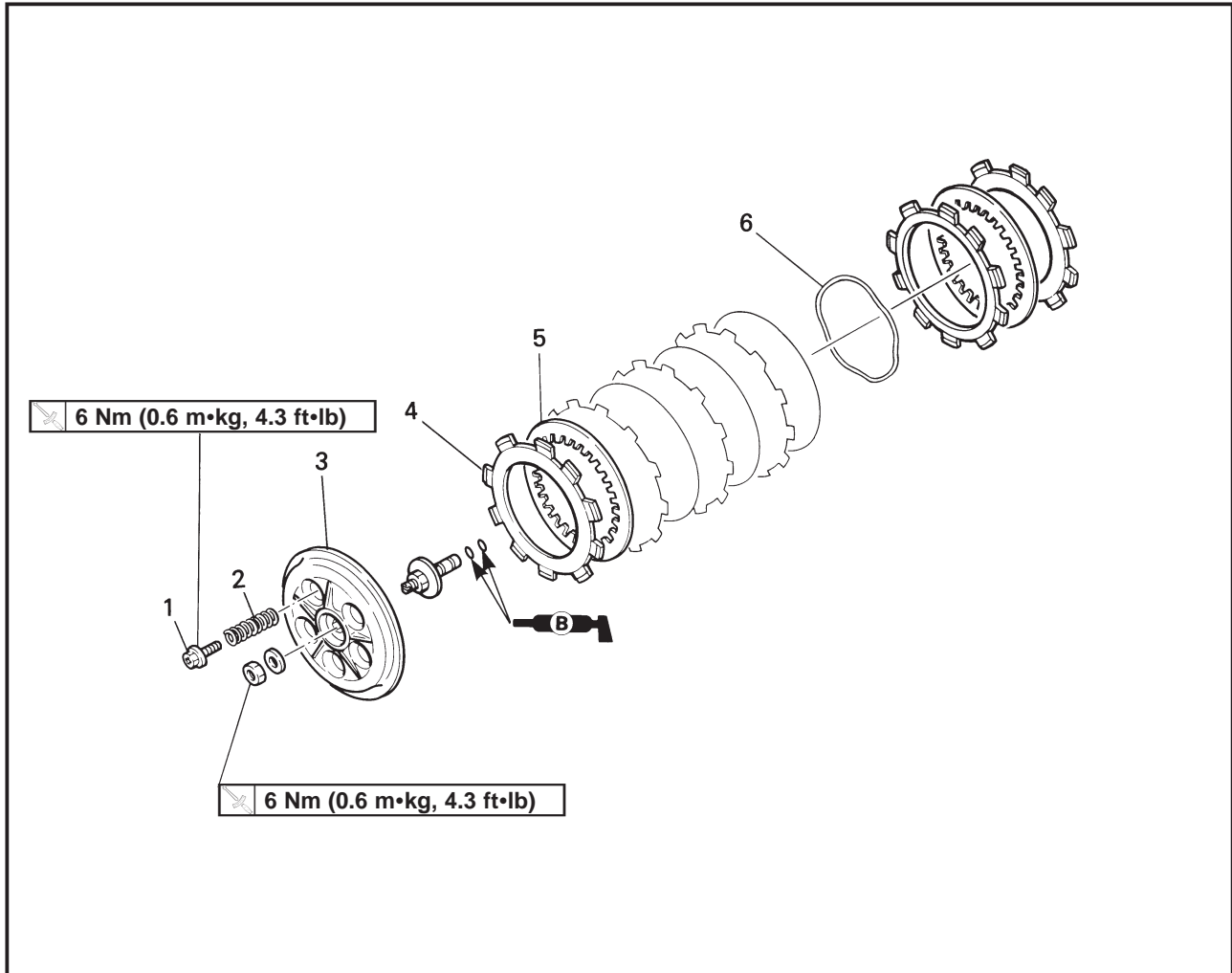

Extend of removal: ① Clutch plate and friction plate removal

Extend of removal	Order	Part name	Q'ty	Remarks
Preparation for removal		CLUTCH PLATE AND FRICTION PLATE REMOVAL		
		Lower cowl		Refer to "COWLING, SEAT AND FUEL TANK" section. Disconnect at engine side.
		Clutch cable		
①	1	Screw (clutch spring)	5	
	2	Clutch spring	5	
	3	Pressure plate	1	
	4	Friction plate	6	
	5	Clutch plate	5	
	6	Cushion spring	1	



EC4A8100

CLUTCH HOUSING AND PUSH LEVER AXLE

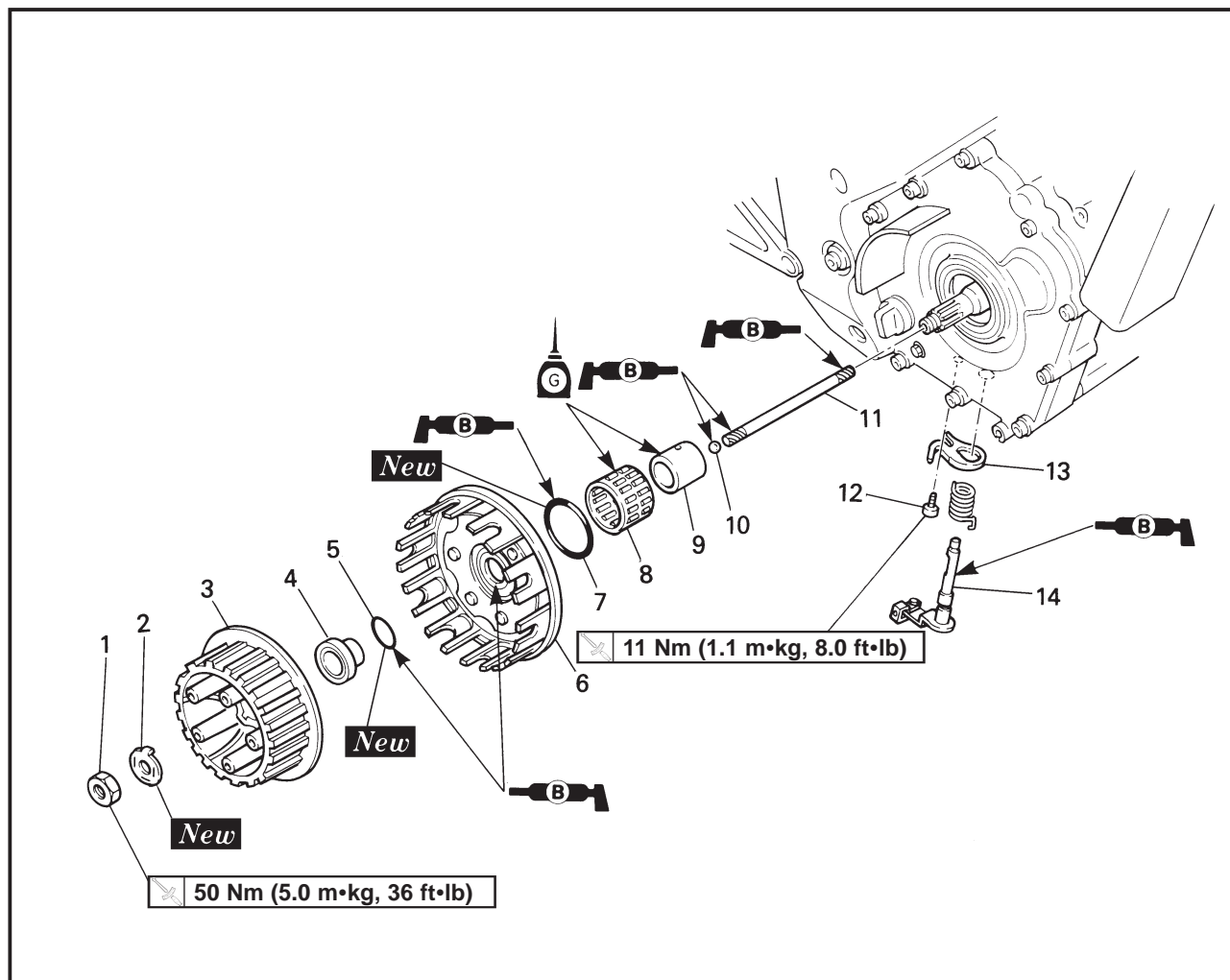

Extend of removal: ① Clutch housing removal ② Push lever axle removal

Extend of removal	Order	Part name	Q'ty	Remarks
① ②		CLUTCH HOUSING AND PUSH LEVER AXLE REMOVAL		
	1	Nut (clutch boss)	1	Use special tool. Refer to "REMOVAL POINTS".
	2	Lock washer	1	
	3	Clutch boss	1	
	4	Spacer 2	1	
	5	O-ring (small)	1	
	6	Clutch housing	1	
	7	O-ring (large)	1	
	8	Bearing	1	
	9	Spacer 1	1	
	10	Ball	1	
	11	Push rod	1	
	12	Bolt (seat plate)	1	
	13	Seat plate	1	
14	Push lever axle	1		

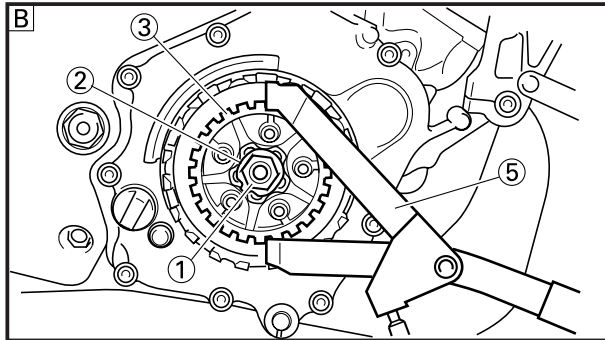
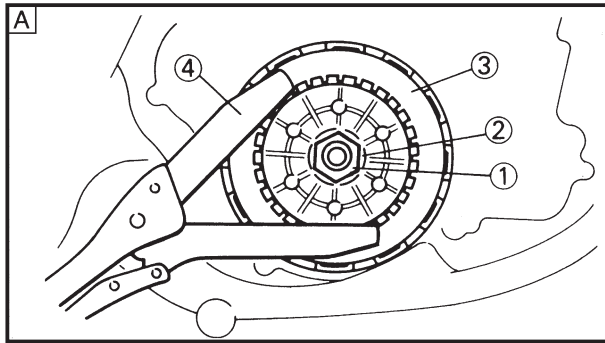

EC4A3000

REMOVAL POINTS

EC483211

Clutch boss

1. Remove:
 - Nut ①
 - Lock washer ②
 - Clutch boss ③

NOTE:

Straighten the lock washer tab and use the clutch holding tool ④, ⑤ to hold the clutch boss.



Clutch holding tool:

- YM-91042④
- 90890-04086⑤

Ⓐ For USA and CDN

Ⓑ Except for USA and CDN

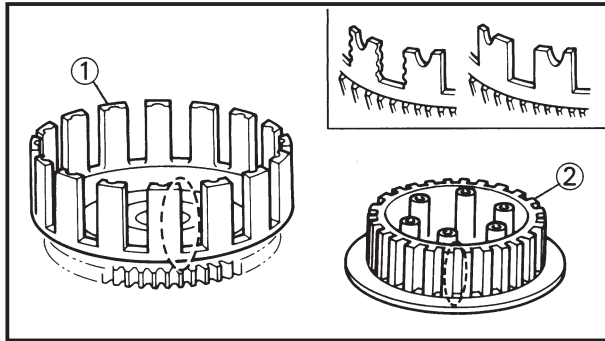

EC4A4000

INSPECTION

EC484100

Clutch housing and boss

1. Inspect:
 - Clutch housing ①
Cracks/Wear/Damage → Replace.
 - Clutch boss ②
Scoring/Wear/Damage → Replace.

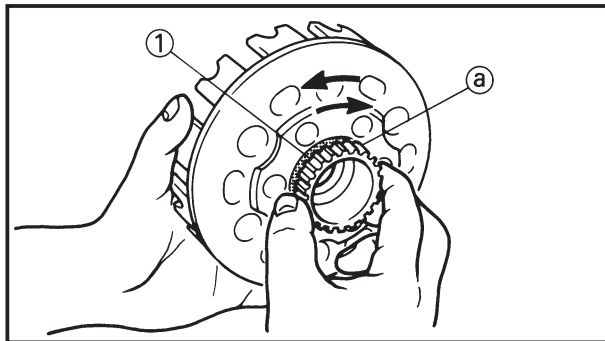

EC4A4100

Clutch housing

1. Check:
 - Circumferential play
Free play exists → Replace.
 - Gear teeth ②
Wear/Damage → Replace.
 - O-ring ①
Damage → Replace.

EC484400

Clutch spring

1. Measure:
 - Clutch spring free length ②
Out of specification → Replace springs as a set.

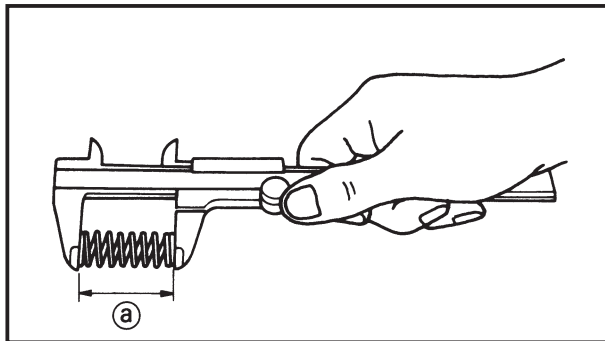

Clutch spring free length:

Standard	<Limit>
36.0 mm (1.417 in)	35.0 mm (1.378 in)

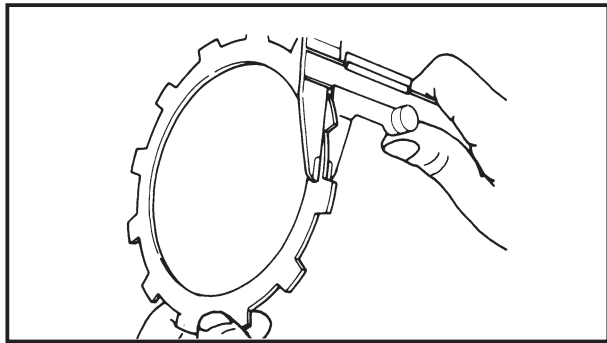

EC484500

Friction plate

1. Measure:

- Friction plate thickness

Out of specification → Replace friction plate as a set.

Measure at all four points.



Friction plate thickness:

Standard	<Limit>
2.9~3.1 mm (0.114~0.122 in)	2.7 mm (0.106 in)

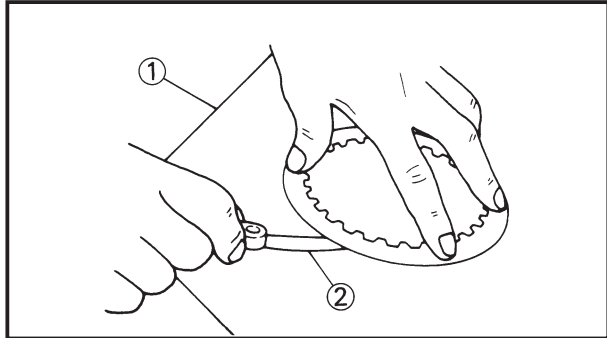

EC484600

Clutch plate

1. Measure:

- Clutch plate warpage

Out of specification → Replace clutch plate as a set.

Use a surface plate ① and thickness gauge ②.



Warp limit:

0.1 mm (0.004 in)

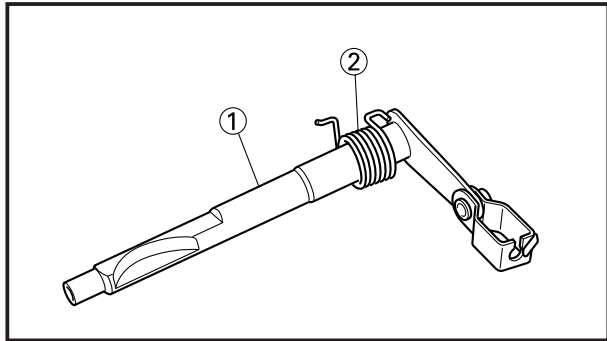

EC4A4200

Push lever axle

1. Inspect:

- Push lever axle ①

Wear/Damage → Replace.

- Torsion spring ②

Broken/Damage → Replace.

EC4A4300

Push rod axle

1. Inspect:

- Push rod ①

- Ball ②

Wear/Damage/Bend → Replace.

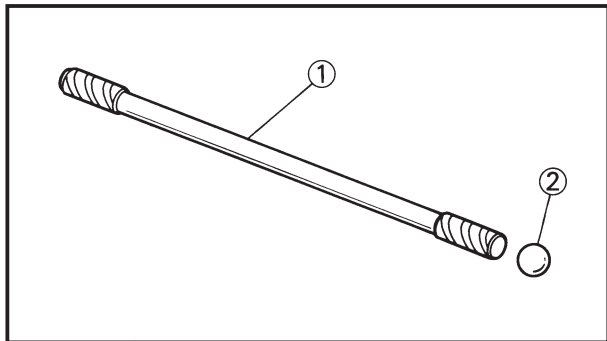

Bending limit:

0.2 mm (0.008 in)

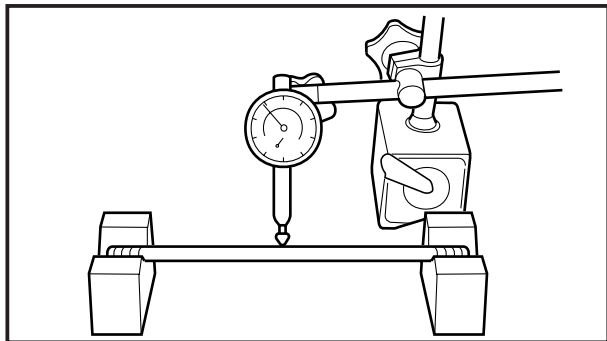

NOTE:

The bending value is shown by one half of the dial gauge reading.

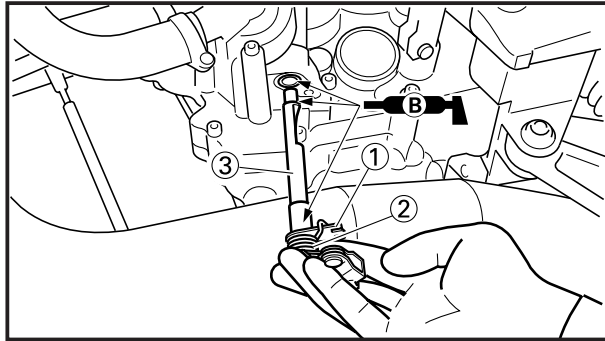

EC4A5000

ASSEMBLY AND INSTALLATION

EC4A5101

Push lever axle

1. Install:
 - Seat plate ①
 - Torsion spring ②
 - Push lever axle ③

NOTE:

Apply the lithium soap base grease on the push lever axle, oil seal lip and bearing.

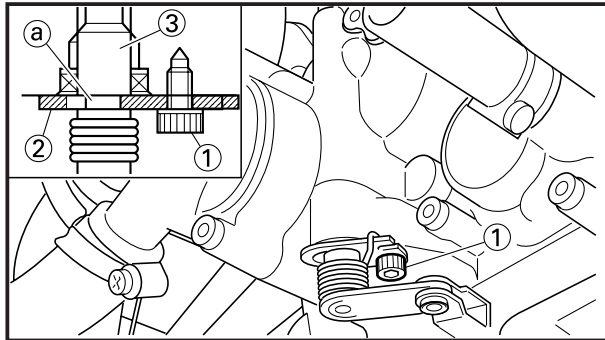

2. Install:

- Bolt (seat plate) ①

11 Nm (1.1 m•kg, 8.0 ft•lb)

NOTE:

Fit the seat plate ② in the groove ① of the push lever axle ③ and tighten the bolt (seat plate).

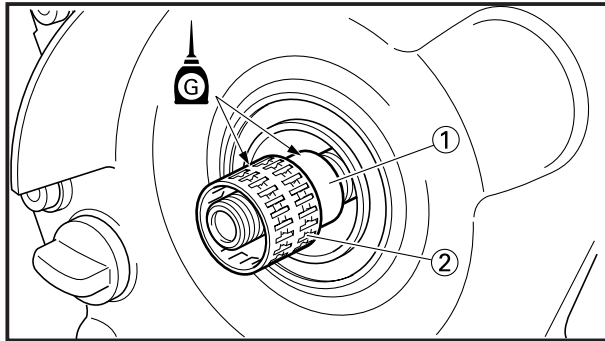

EC4A5221

Clutch

1. Install:
 - Spacer 1 ①
 - Bearing ②

NOTE:

Apply the transmission oil on the spacer 1 and bearing.

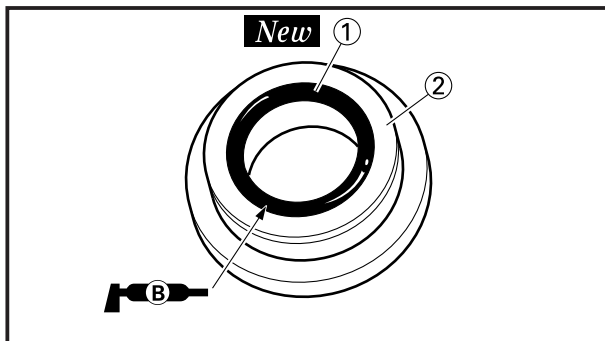

2. Install:

- O-ring ① **New**
To spacer 2 ②.

NOTE:

Apply the lithium soap base grease on the O-ring.

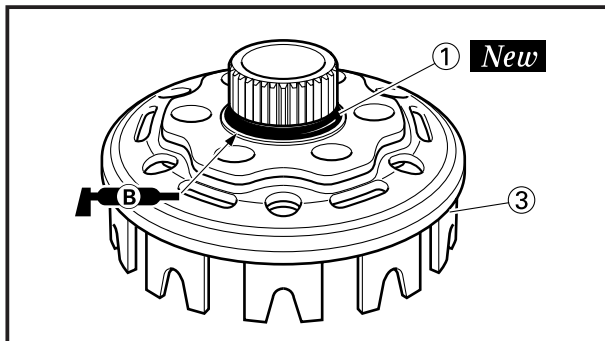

3. Install:
- O-ring ① **New**
 - Spacer 2 ②
- To clutch housing ③.

NOTE:

- Apply the lithium soap base grease on the O-ring and oil seal lip.
- When installing the spacer 2, pay careful attention to the clutch housing oil seal lip (a).

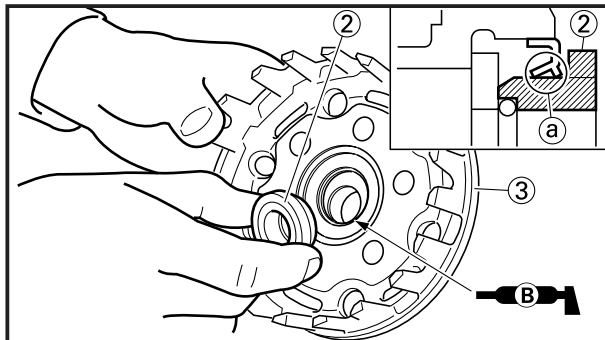

4. Install:
- Clutch housing ①
 - Clutch boss ②

NOTE:

Install the clutch housing with the clutch boss pushed on it so that the spacer 2 will not come off.

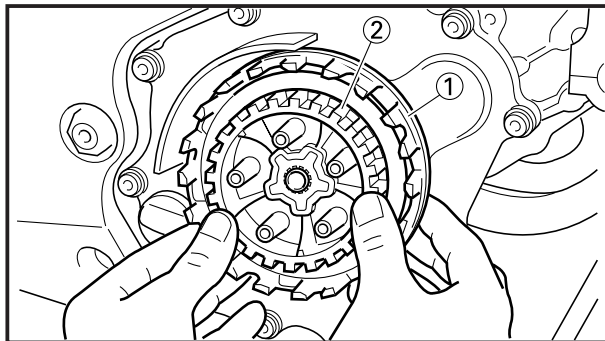

5. Install:
- Lock washer ① **New**
 - Nut (clutch boss) ②

50 Nm (5.0 m•kg, 36 ft•lb)

NOTE:

Use the clutch holding tool ③, ④ to hold the clutch boss.

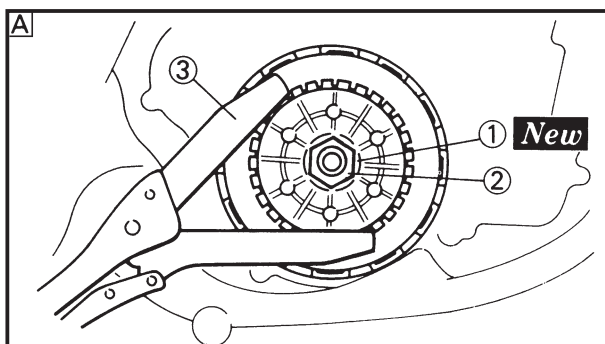

	Clutch holding tool:
	YM-91042③
	90890-04086④

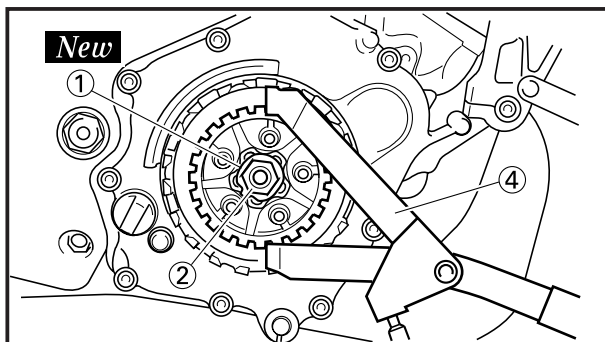

- Ⓐ For USA and CDN
- Ⓑ Except for USA and CDN

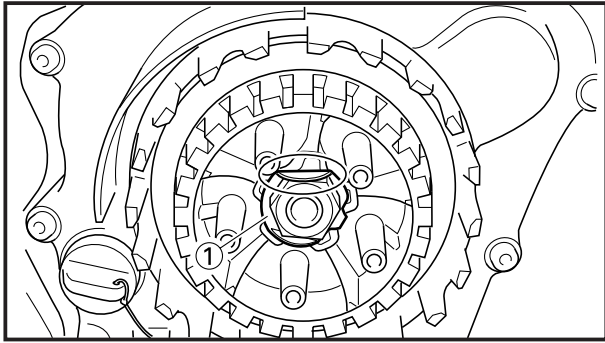

6. Bend the lock washer ① tab.

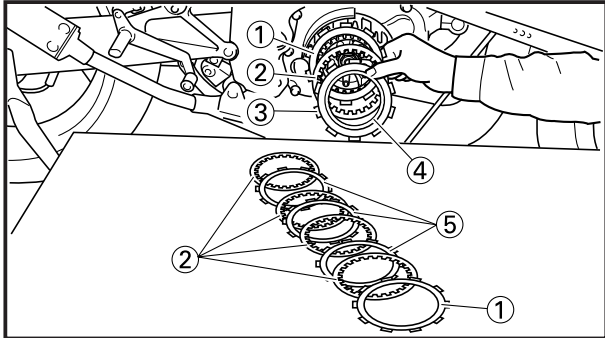

7. Install:

- Friction plate
{yellow [d=Ø95 mm (3.7 in)]} ①
- Clutch plate ②
- Friction plate
{brown [d=Ø100mm (3.9 in)]} ③
- Cushion spring ④
- Friction plate
{brown [d=Ø95 mm (3.7 in)]} ⑤

NOTE:

- Install the clutch plates and friction plates alternately on the clutch boss, starting with a friction plate and ending with a friction plate.
- Yellow colored friction plates are used for the first and final.
- Install the larger inner diameter friction plate [d=Ø100 mm (3.9 in)] together with the cushion spring, and place them at second from the innermost.
- If grease or oil sticks to any of the clutch plates, friction plates and cushion spring, be sure to clean them with solvent or replace them.

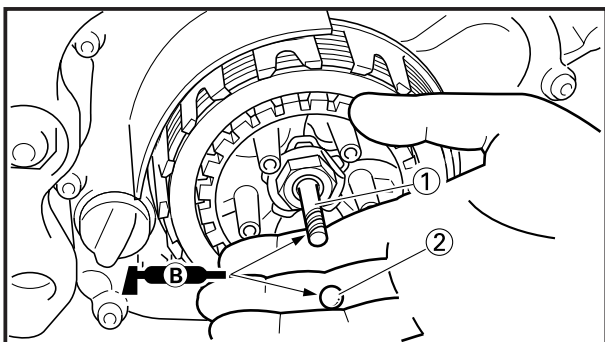

8. Install:

- Push rod ①
- Ball ②

NOTE:

Apply the lithium soap base grease on the push rod and ball.

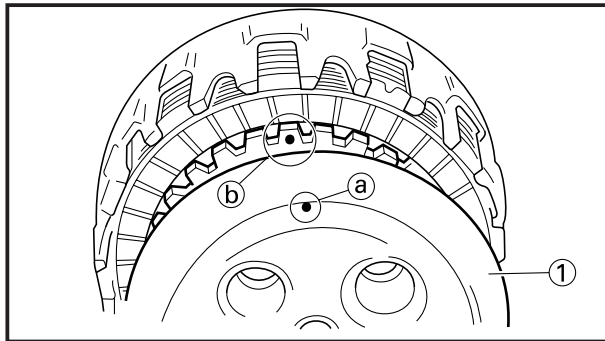

9. Install:
- Pressure plate ①

NOTE:

Align the punch mark (a) on the pressure plate with the punch mark (b) on the clutch boss.

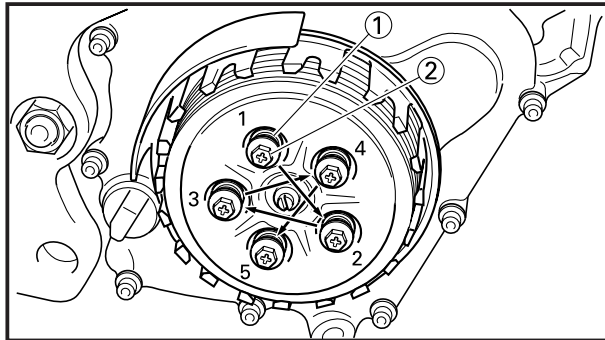

10. Install:
- Clutch spring ①
 - Screw (clutch spring) ②

 6 Nm (0.6 m•kg, 4.3 ft•lb)

NOTE:

Tighten the screws in stages, using a criss-cross pattern.

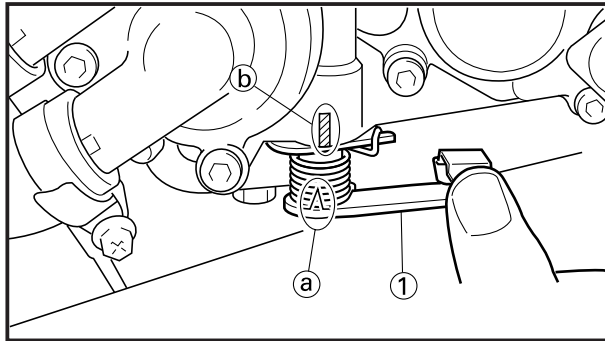

11. Check:
- Push lever position

Push the push lever ① forward until it stops. With the push lever in this position, the projection (a) of the push lever should be aligned with the mating mark (b) on the crankcase.

Not aligned → Adjust.

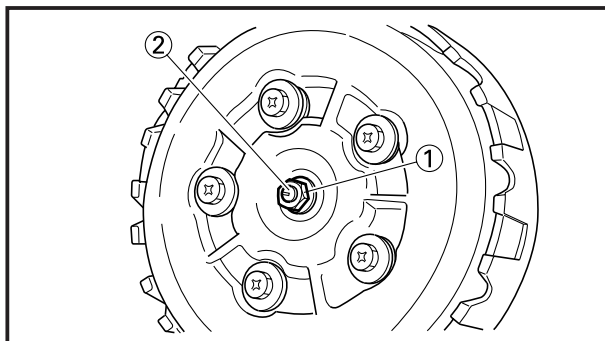

12. Adjust:
- Push lever position

Push lever position adjustment steps:

- Loosen the locknut ①.
- Turn the adjuster ② to align the projection of the push lever with the mating mark on the crankcase.
- Tighten the locknut.



Locknut:

6 Nm (0.6 m•kg, 4.3 ft•lb)

PRIMARY DRIVEN GEAR, PRIMARY DRIVE GEAR AND BALANCER SHAFT



EC4D0002

PRIMARY DRIVEN GEAR, PRIMARY DRIVE GEAR AND BALANCER SHAFT

EC4D8000

PRIMARY DRIVEN GEAR

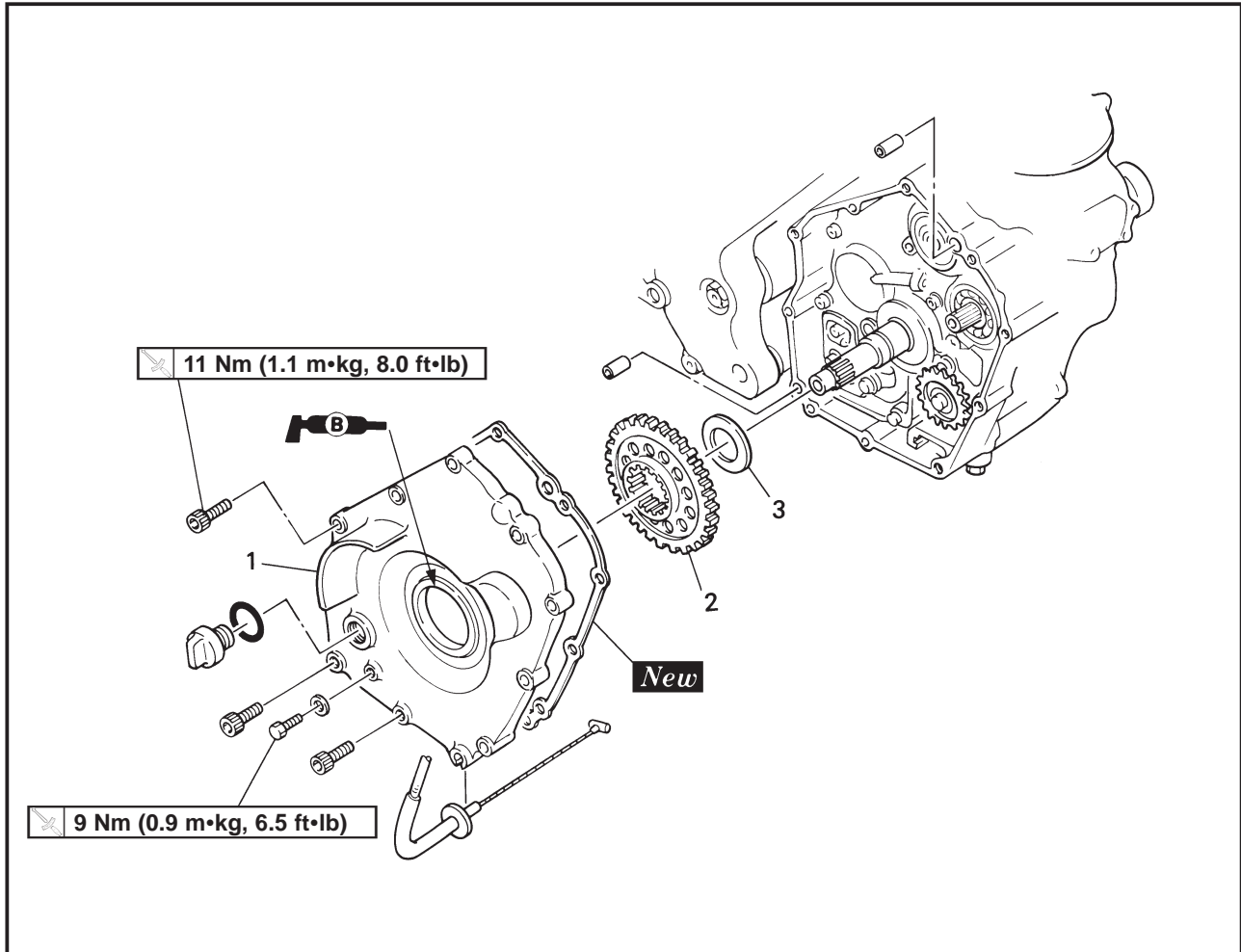

Extend of removal: ① Primary driven gear removal

Extend of removal	Order	Part name	Q'ty	Remarks
Preparation for removal		PRIMARY DRIVEN GEAR REMOVAL		
		Lower cowl		Refer to "COWLING, SEAT AND FUEL TANK" section.
		Exhaust pipe		Refer to "EXHAUST PIPE AND SILENCER" section.
		Clutch Drain the transmission oil.		Refer to "CLUTCH" section. Refer to "TRANSMISSION OIL REPLACEMENT" section in the CHAPTER 3.
		Rotor		Refer to "CDI MAGNETO" section.
<div style="text-align: center;"> ↑ ① ↓ </div>	1	Crankcase cover (right)	1	
	2	Primary driven gear	1	
	3	Thrust plate	1	

PRIMARY DRIVEN GEAR, PRIMARY DRIVE GEAR AND BALANCER SHAFT



EC4D8100

PRIMARY DRIVE GEAR AND BALANCER SHAFT

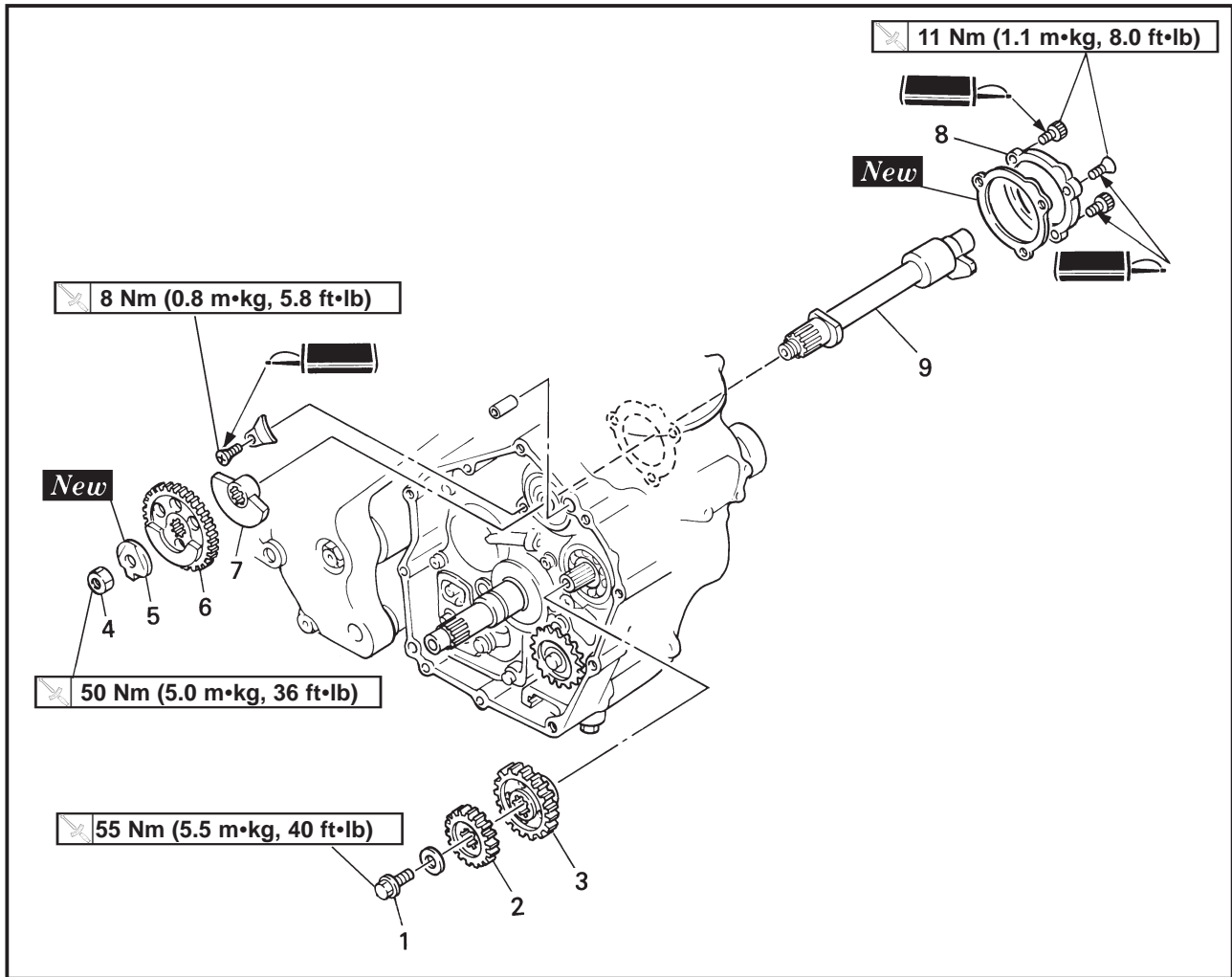

Extend of removal: ① Primary drive gear removal ② Balancer shaft removal

Extend of removal	Order	Part name	Q'ty	Remarks
<div style="display: flex; align-items: center;"> <div style="margin-right: 20px;"> <p>①</p> <p>↑</p> <p>↓</p> </div> <div style="margin-right: 20px;"> <p>↑</p> </div> <div style="margin-right: 20px;"> <p>②</p> <p>↑</p> <p>↓</p> </div> </div>	PRIMARY DRIVE GEAR AND BALANCER SHAFT REMOVAL			
	1	Bolt (primary drive gear)	1	} Refer to "REMOVAL POINTS".
	2	Primary drive gear	1	
	3	Balancer drive gear	1	
	4	Nut (balancer weight gear)	1	
	5	Lock washer	1	
	6	Balancer weight gear	1	
	7	Weight	1	
	8	Crankcase cover (left)	1	} Refer to "REMOVAL POINTS".
9	Balancer shaft	1		

PRIMARY DRIVEN GEAR, PRIMARY DRIVE GEAR AND BALANCER SHAFT

ENG

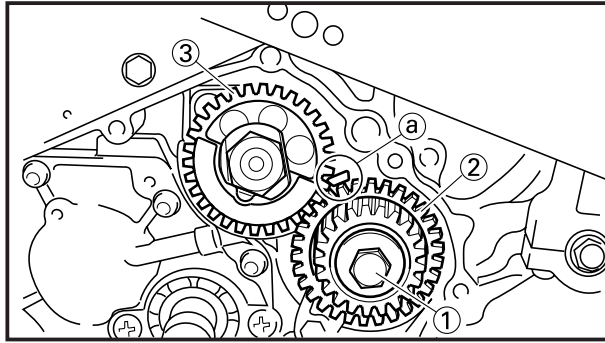

EC4D3000

REMOVAL POINTS

EC4D3101

Primary drive gear and balancer weight gear

1. Loosen:

- Bolt (primary drive gear) ①

NOTE:

Place an aluminum plate ② between the teeth of the balancer drive gear ② and balancer weight gear ③.

2. Loosen:

- Nut (balancer weight gear) ①

NOTE:

Straighten the lock washer ② tab and place an aluminum plate ② between the teeth of the balancer drive gear ③ and balancer weight gear ④.

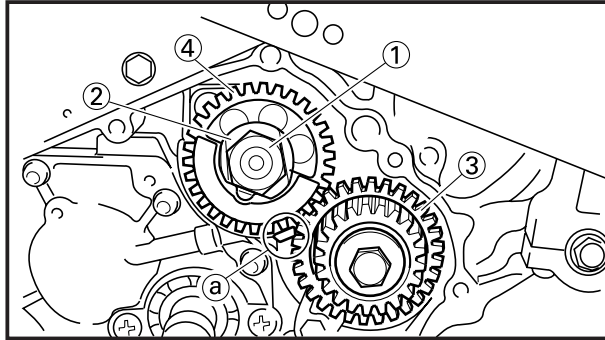

3. Remove:

- Bolt (primary drive gear) ①
- Primary drive gear ②
- Balancer drive gear ③
- Nut (balancer weight gear) ④
- Lock washer ⑤
- Balancer weight gear ⑥

NOTE:

It may sometimes happens that the primary drive gear and balancer drive gear are fitted too tight as in force fitting. In that case, use a general gear puller to remove them without too much force on the crankshaft.

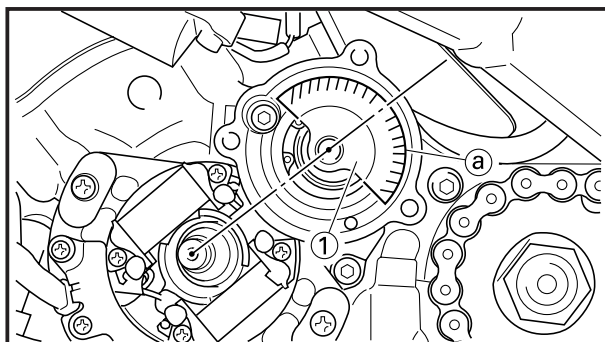
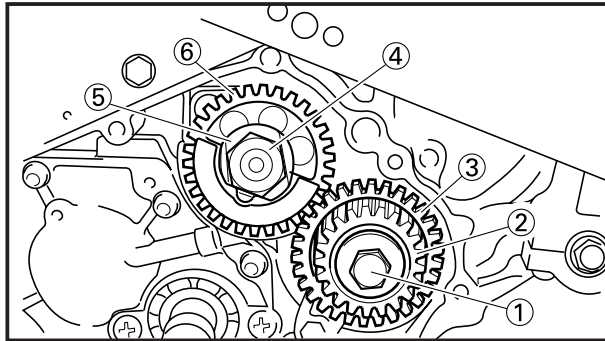

EC4D3200

Balancer shaft

1. Remove:

- Balancer shaft ①

NOTE:

When removing the balancer shaft, align the center of the balancer shaft weight ② along the line connecting the centers of the crankshaft and balancer shaft.

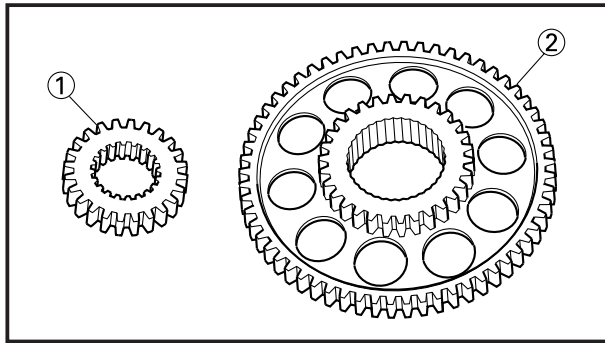

EC4D4000

INSPECTION

EC484300

Primary drive gear and primary driven gear

1. Inspect:

- Primary drive gear ①
 - Primary driven gear ②
- Wear/Damage → Replace.

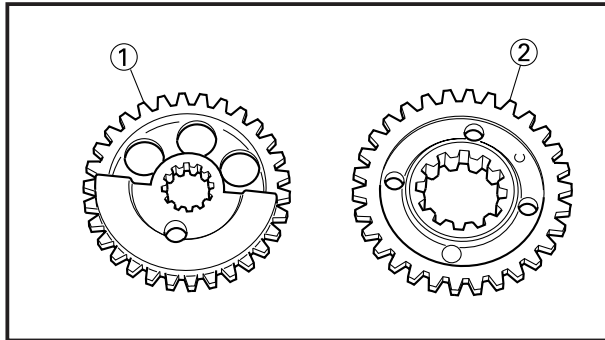

EC4D4200

Balancer weight gear and balancer drive gear

1. Inspect:

- Balancer weight gear ①
 - Balancer drive gear ②
- Wear/Damage → Replace.

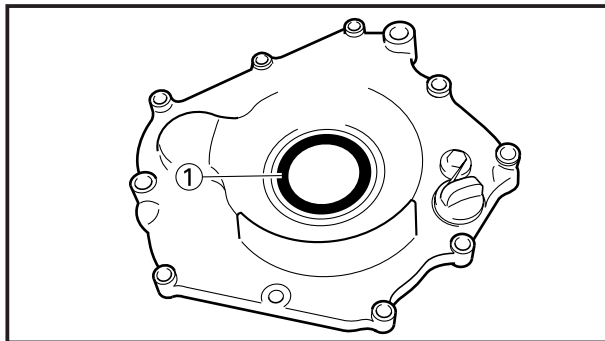

EC4D4300

Crankcase cover (right)

1. Inspect:

- Contacting surface
Scratches → Replace.
- Crankcase cover (right)
Cracks/Damage → Replace.
- Oil seal ①
Wear/Damage → Replace.

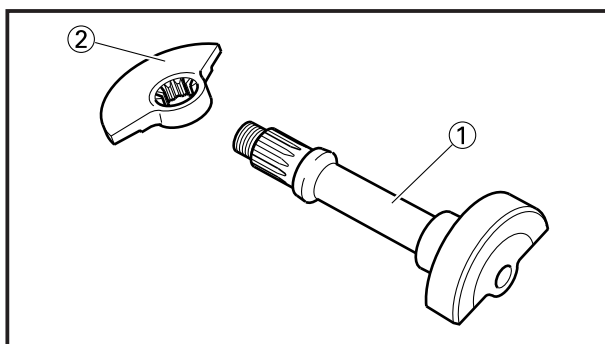

EC4D4400

Balancer shaft and weight

1. Inspect:

- Balancer shaft ①
Bend/Wear/Damage → Replace.
- Weight ②
Damage → Replace.

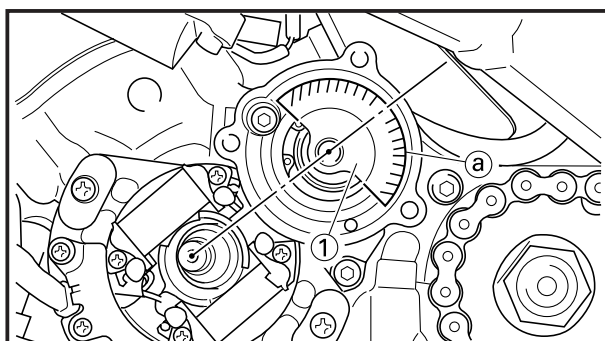

EC4D5000

ASSEMBLY AND INSTALLATION

EC4D5122

Balancer shaft and primary drive gear

1. Install:

- Balancer shaft ①

NOTE:

When installing the balancer shaft, align the center of the balancer shaft weight ② along the line connecting the centers of the crankshaft and balancer shaft.

PRIMARY DRIVEN GEAR, PRIMARY DRIVE GEAR AND BALANCER SHAFT

ENG

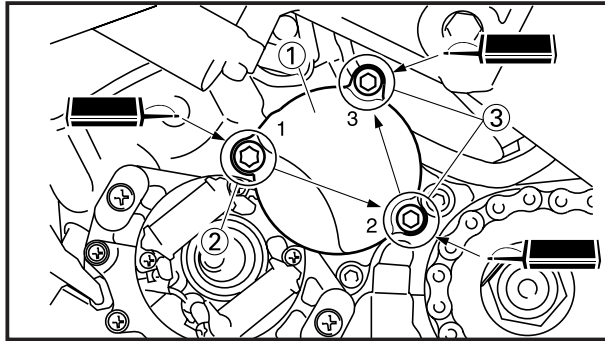

2. Install:

- Gasket [crankcase cover (left)] **New**
- Crankcase cover (left) ①
- Screw [crankcase cover (left)] ②

11 Nm (1.1 m•kg, 8.0 ft•lb)

- Bolt [crankcase cover (left)] ③

11 Nm (1.1 m•kg, 8.0 ft•lb)

NOTE:

- Be sure to tighten in numbered order as shown.
- Tighten the screw using the T30 bit.

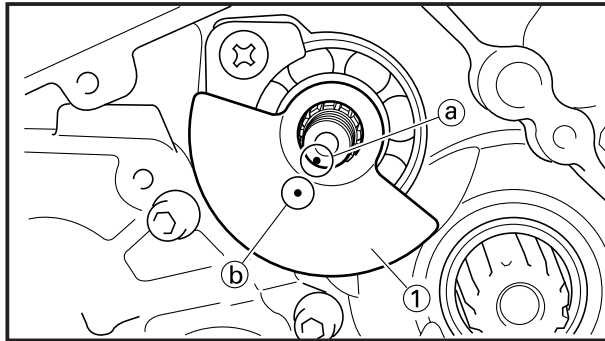

3. Install:

- Weight ①

NOTE:

Align the punch mark (a) on the balancer shaft with the punch mark (b) on the weight.

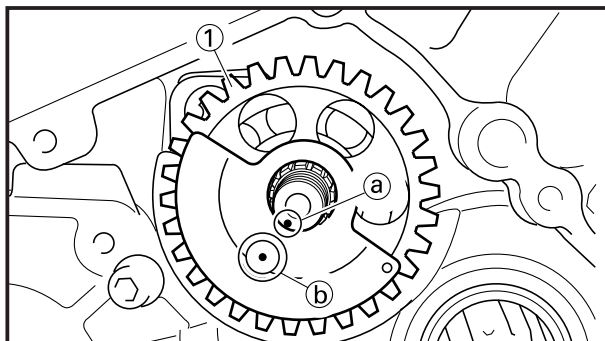

4. Install:

- Balancer weight gear ①

NOTE:

Align the punch mark (a) on the balancer shaft with the hole (b) of the balancer weight gear.

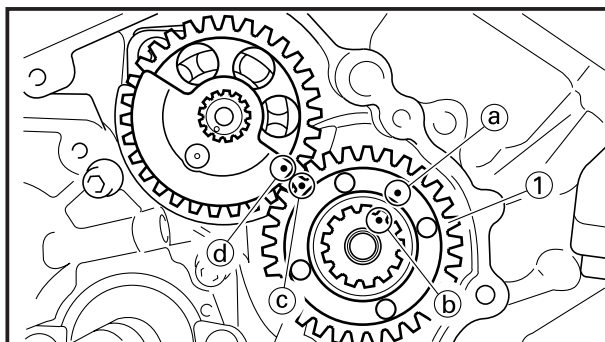

5. Install:

- Balancer drive gear ①

NOTE:

Align the punch marks, (a) (balancer drive gear) with (b) (crankshaft) and (c) (balancer drive gear) with (d) (balancer weight gear) as shown.

PRIMARY DRIVEN GEAR, PRIMARY DRIVE GEAR AND BALANCER SHAFT

ENG

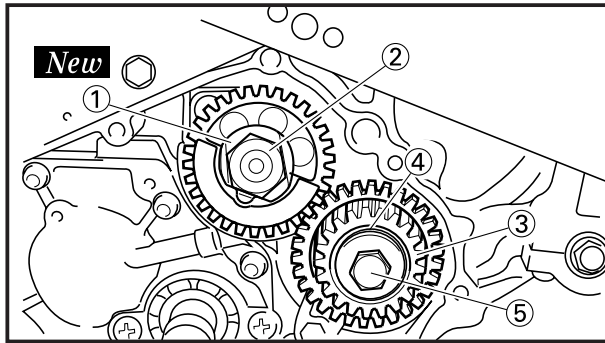

6. Install:
- Lock washer ① **New**
 - Nut (balancer weight gear) ②
 - Primary drive gear ③
 - Plain washer ④
 - Bolt (primary drive gear) ⑤

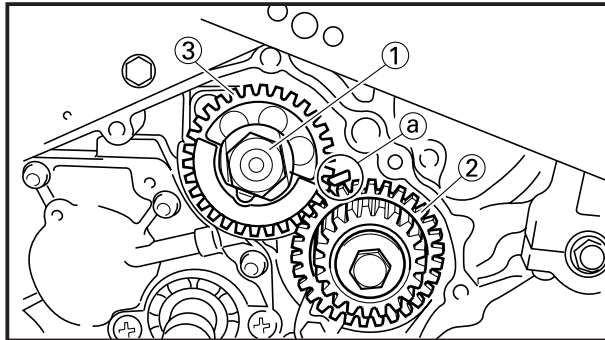

7. Tighten:
- Nut (balancer weight gear) ①
- 50 Nm (5.0 m•kg, 36 ft•lb)**

NOTE: Place an aluminum plate ③ between the teeth of the balancer drive gear ② and balancer weight gear ③.

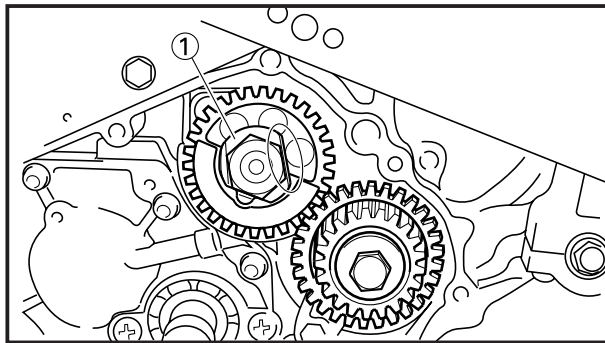

8. Bend the lock washer ① tab.

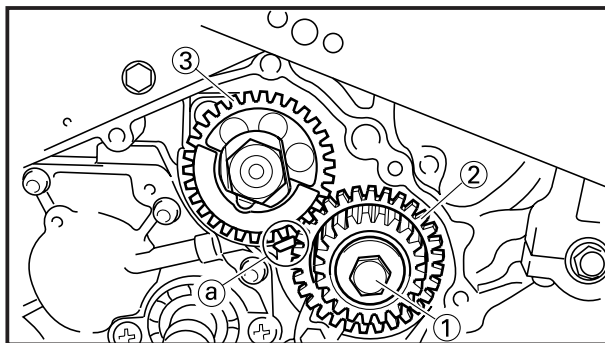

9. Tighten:
- Bolt (primary drive gear) ①
- 55 Nm (5.5 m•kg, 40 ft•lb)**

NOTE: Place an aluminum plate ③ between the teeth of the balancer drive gear ② and balancer weight gear ③.

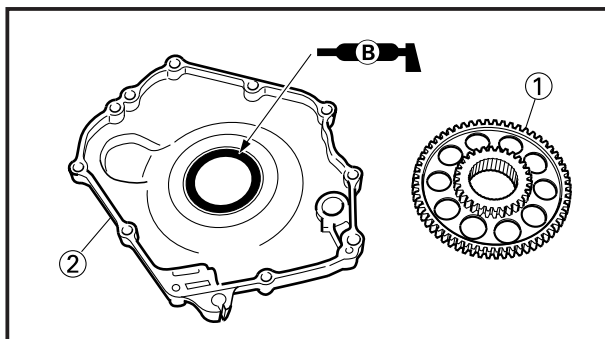

EC4D5202

Primary driven gear

1. Install:
- Primary driven gear ①
- To crankcase cover (right) ②.

NOTE: Apply the lithium soap base grease on the oil seal lip.

PRIMARY DRIVEN GEAR, PRIMARY DRIVE GEAR AND BALANCER SHAFT

ENG

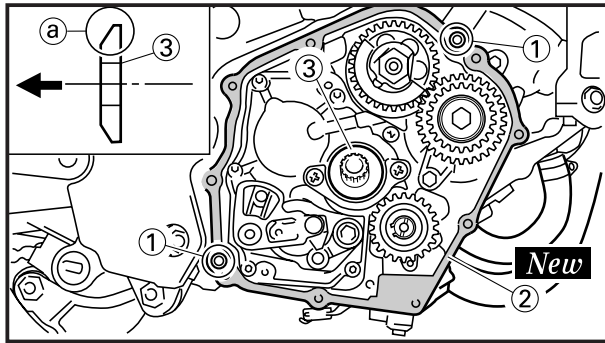

2. Install:

- Dowel pin ①
- Gasket [crankcase cover (right)] ② **New**
- Thrust plate ③

NOTE: _____

Install the thrust plate with its chamfered portion ② toward the transmission.

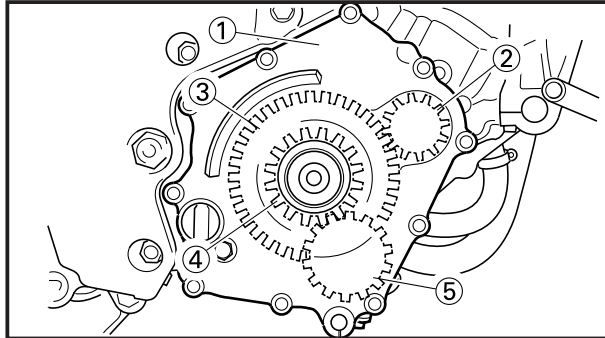

3. Install:

- Crankcase cover (right) ①

NOTE: _____

Mesh the primary drive gear ② with the primary driven gear ③, and the oil pump drive gear ④ with the oil pump driven gear ⑤ by turning the rotor.

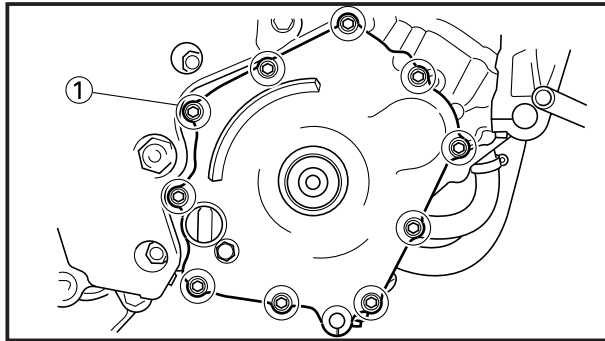

4. Install:

- Bolt [crankcase cover (right)] ①

11 Nm (1.1 m•kg, 8.0 ft•lb)

NOTE: _____

Tighten the bolts in stages, using a crisscross pattern.



EC4E0000

SHIFT SHAFT AND OIL PUMP



EC4E8000

SHIFT SHAFT

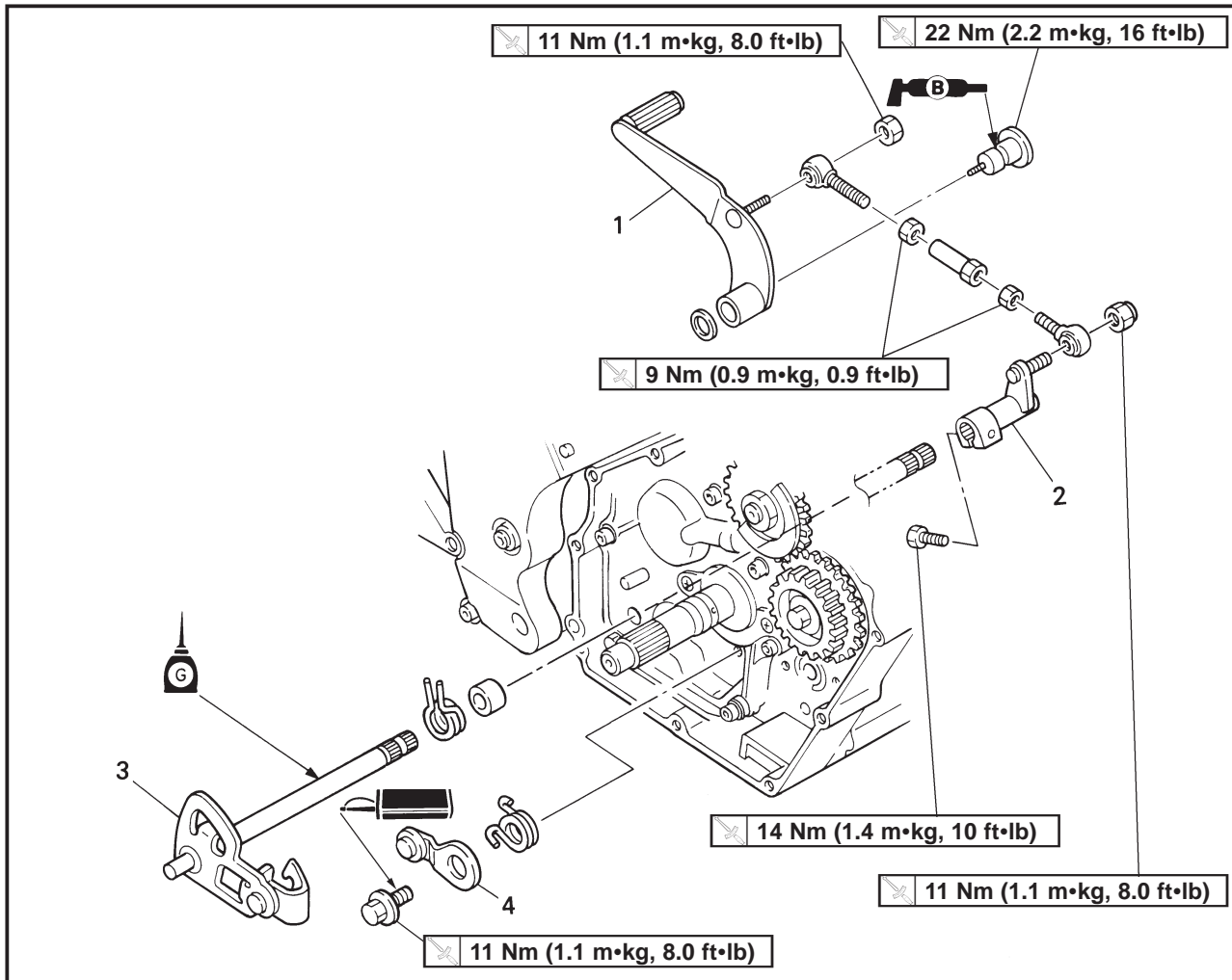

Extend of removal: ① Shift shaft removal ② Stopper lever removal

Extend of removal	Order	Part name	Q'ty	Remarks
Preparation for removal		SHIFT SHAFT REMOVAL		
		Lower cowl		Refer to "COWLING, SEAT AND FUEL TANK" section.
		Exhaust pipe		Refer to "EXHAUST PIPE AND SILENCER" section.
		Clutch Drain the transmission oil.		Refer to "CLUTCH" section. Refer to "TRANSMISSION OIL REPLACEMENT" section in the CHAPTER 3.
		Crankcase cover (right)		Refer to "PRIMARY DRIVEN GEAR, PRIMARY DRIVE GEAR AND BALANCER SHAFT" section.
①	1	Shift pedal	1	
	2	Shift arm	1	
	3	Shift shaft	1	
	4	Stopper lever	1	



EC4E8100

OIL PUMP

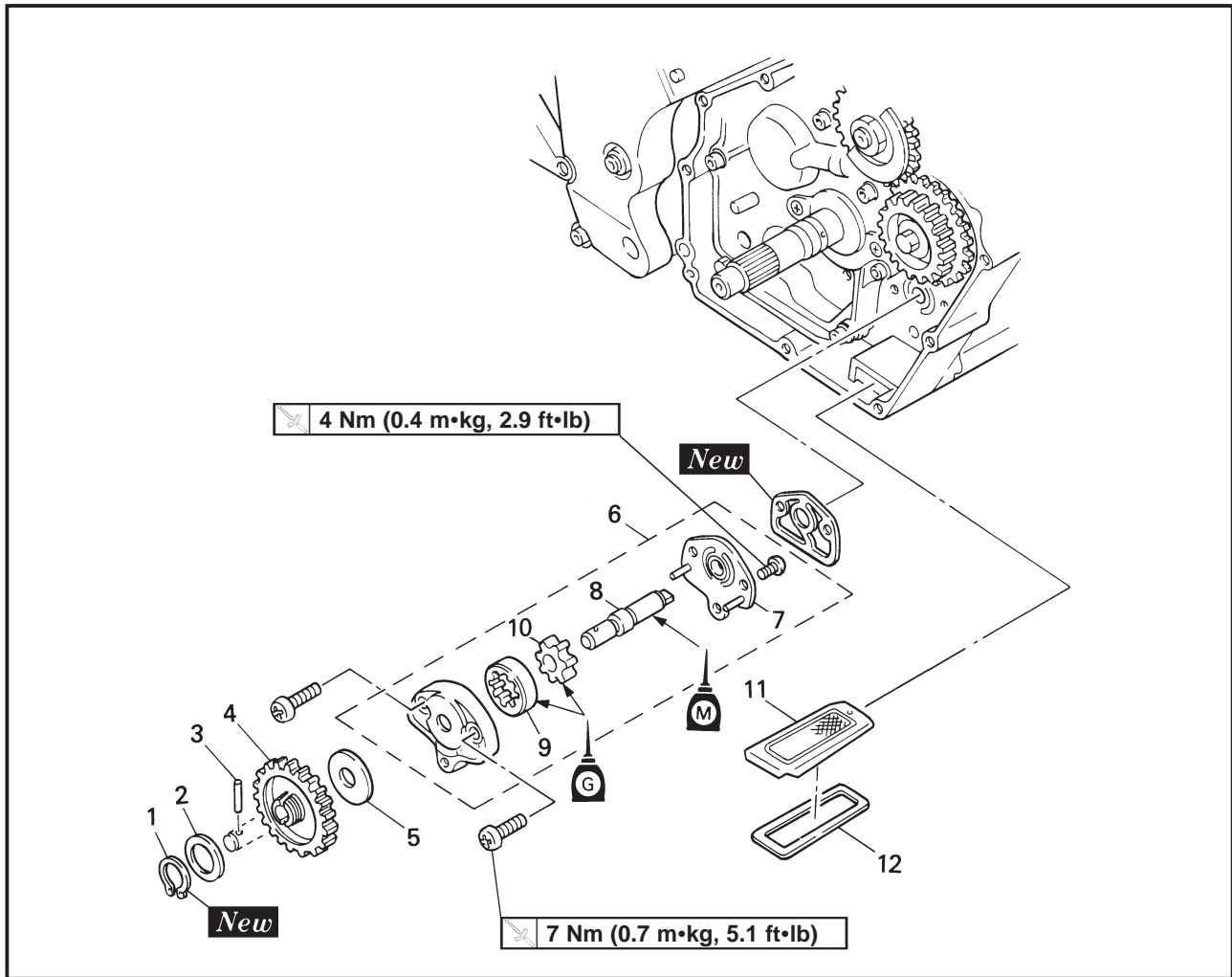

Extend of removal: ① Oil pump removal and disassembly ② Strainer removal

Extend of removal	Order	Part name	Q'ty	Remarks	
<div style="display: flex; align-items: center;"> <div style="margin-right: 20px;"> ↑ ① ↓ </div> <div style="margin-right: 20px;"> ↑ ② ↓ </div> </div>	OIL PUMP REMOVAL				
	1	Circlip	1		
	2	Plain washer	1		
	3	Dowel pin	1		
	4	Oil pump driven gear	1		
	5	Shim	1		
	6	Oil pump assembly	1		
	7	Oil pump cover	1		
	8	Oil pump shaft	1		
	9	Outer rotor	1		
	10	Inner rotor	1		
	11	Strainer 1	1		
12	Strainer 2	1			

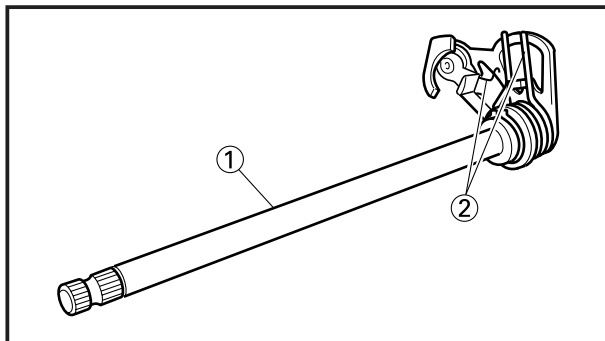

EC4E4000

INSPECTION

EC4B4400

Shift shaft

- Inspect:
 - Shift shaft ①
Bend/Damage → Replace.
 - Spring ②
Broken → Replace.

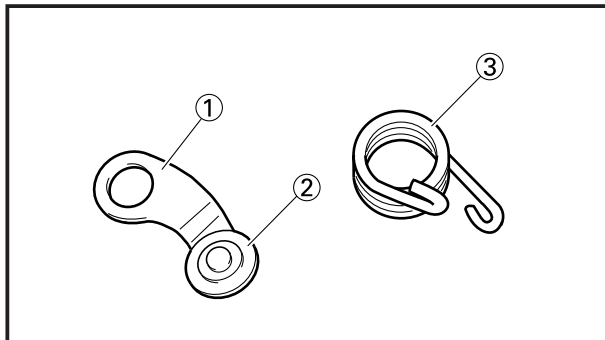

EC4E4100

Stopper lever

- Inspect:
 - Stopper lever ①
Wear/Damage → Replace.
 - Bearing ②
Rotate outer race with a finger.
Rough spot/Seizure → Replace the stopper lever.
 - Torsion spring ③
Broken → Replace.

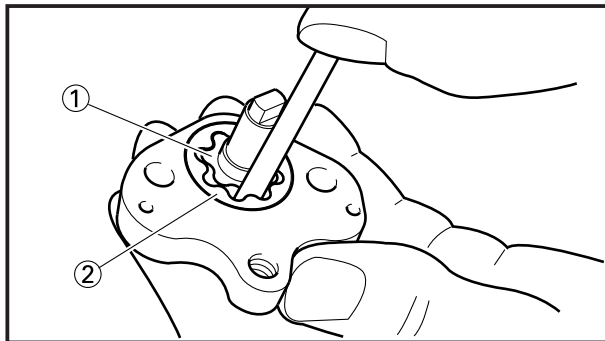

EC4E4200

Oil pump

- Measure:
 - Tip clearance
Measure the clearance between the inner rotor ① and outer rotor ②.
Out of limit → Replace the inner rotor and outer rotor as a set.



Tip clearance limit:
0.15 mm (0.0059 in)

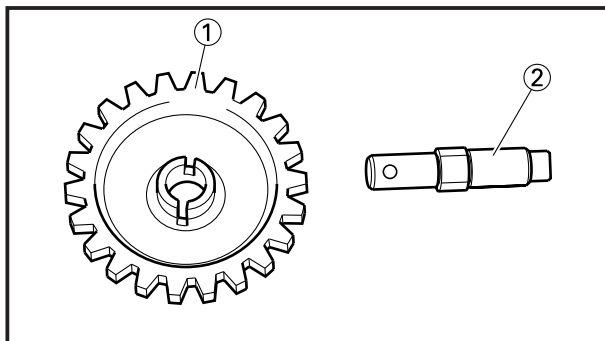

- Inspect:
 - Oil pump driven gear ①
 - Oil pump shaft ②
Wear/Damage → Replace.

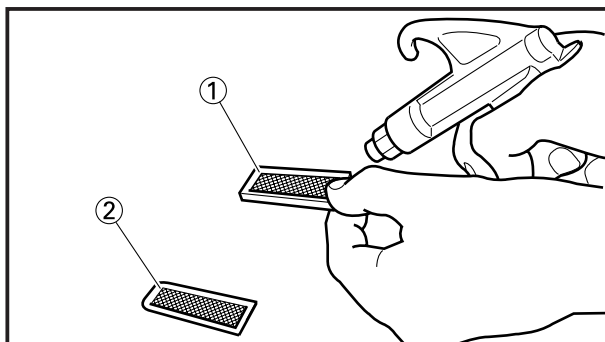

EC4E4301

Strainer

- Clean:
 - Strainer 1 ①
 - Strainer 2 ②
Use compressed air.

NOTE:

- Clean the strainer every 500 km (300 miles).
- If a lot of metallic dust is noticed, disassemble the engine and check.

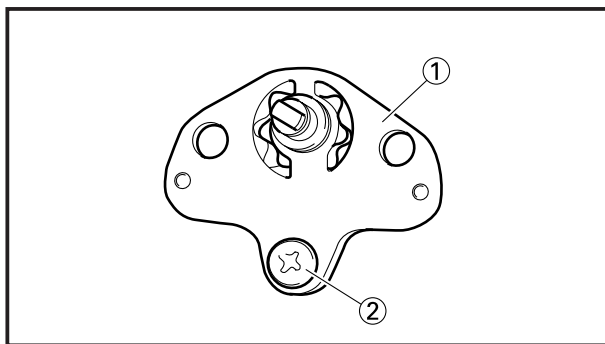
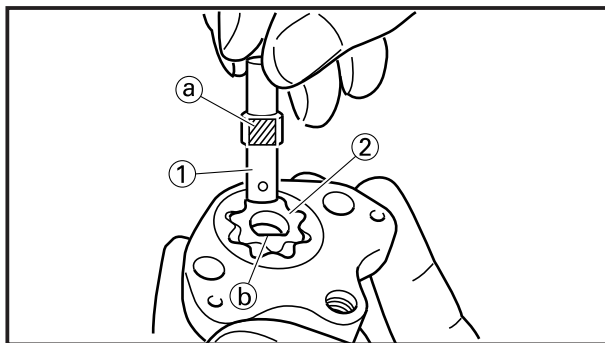
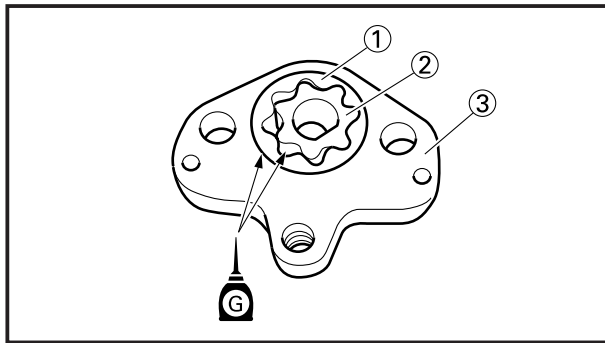
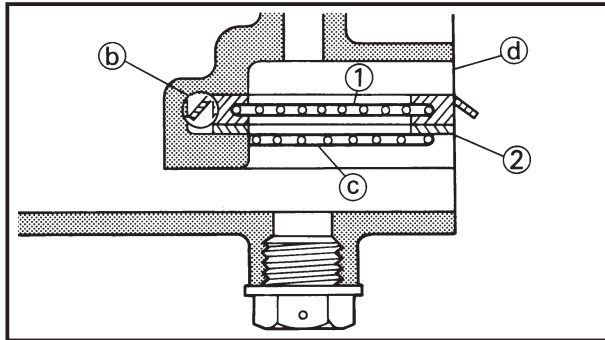
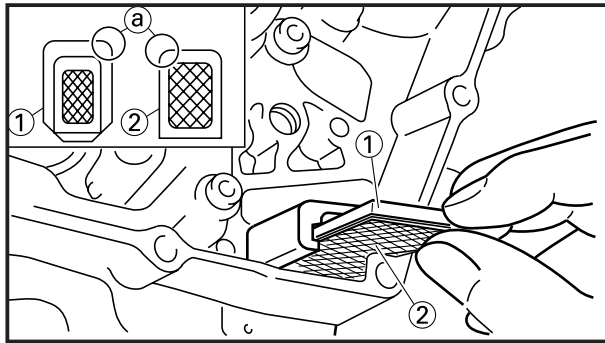

EC4E5000

ASSEMBLY AND INSTALLATION

EC4E5101

Strainer

1. Install:

- Strainer 1 ①
- Strainer 2 ②

NOTE:

- Each strainer is installed with the rounded corner ① facing inward.
- Strainer 1 is installed with the flange ② facing downward.
- Strainer 2 is installed with the mesh ③ facing downward.
- After installing the strainers, make sure the strainer 1 and 2 are not protruding from the crankcase surface ④.

EC4E5202

Oil pump

1. Install:

- Outer rotor ①
- Inner rotor ②
- To oil pump housing ③.

NOTE:

Apply the transmission oil on the inner rotor and outer rotor.

2. Install:

- Oil pump shaft ①
- To inner rotor ②.

NOTE:

Install the oil pump shaft with its flat portion ① placed on the flat portion ② of the inner rotor.

3. Install:

- Oil pump cover ①
- Screw (oil pump cover) ②

4 Nm (0.4 m•kg, 2.9 ft•lb)

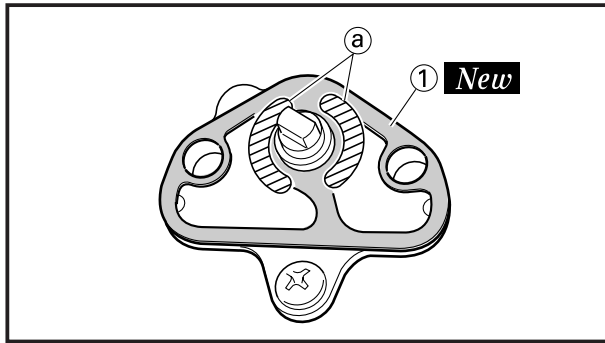

4. Install:
- Gasket (oil pump) ① **New**

NOTE: _____
 Install the gasket in accordance with the shapes of the oil passages ①.

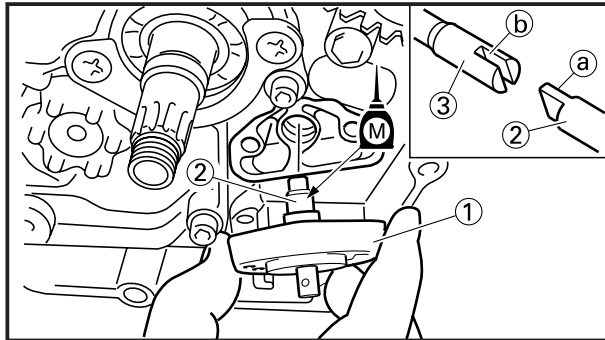

5. Install:
- Oil pump assembly ①
- NOTE:** _____
- Apply the molybdenum disulfide oil on the oil pump shaft ②.
 - When installing the oil pump assembly, turn the oil pump shaft until its key end ① is in the recess ② of the impeller shaft ③.

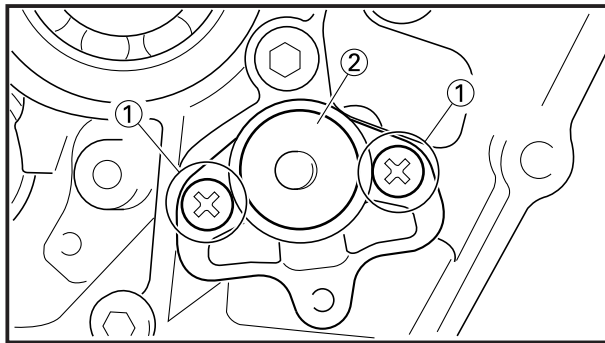

6. Install:
- Screw (oil pump assembly) ①
- 7 Nm (0.7 m•kg, 5.1 ft•lb)**
- Shim ②

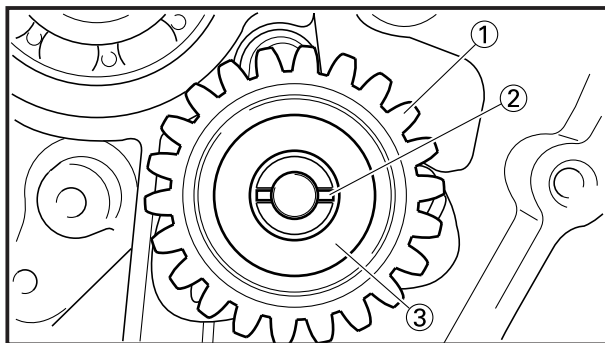

7. Install:
- Oil pump driven gear ①
 - Dowel pin ②
 - Plain washer ③

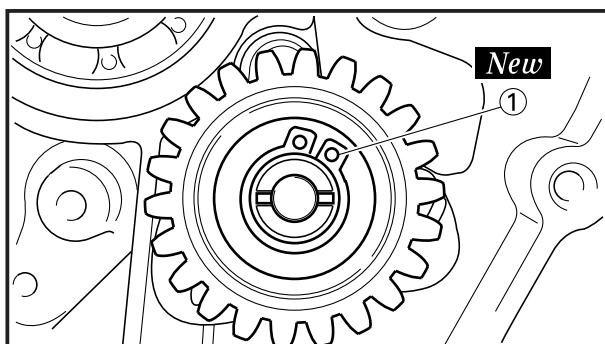

8. Install:
- Circlip ① **New**

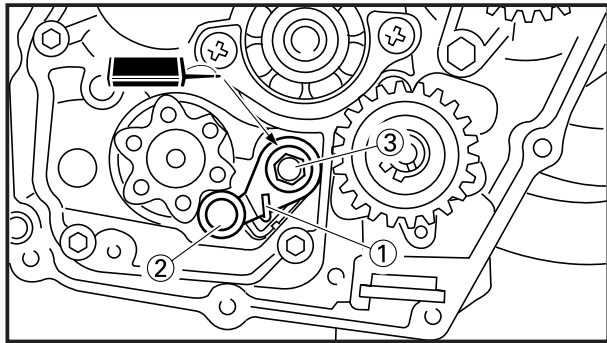

EC4B5111

Stopper lever

1. Install:

- Torsion spring ①
- Stopper lever ②
- Bolt (stopper lever) ③

11 Nm (1.1 m•kg, 8.0 ft•lb)

NOTE:

Align the stopper lever roller with the slot on segment.

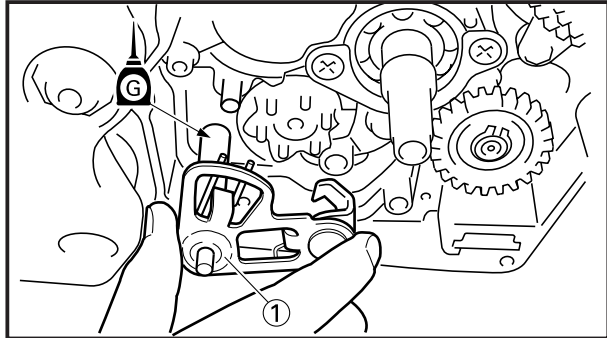

EC4E5310

Shift shaft

1. Install:

- Shift shaft ①

NOTE:

Apply the transmission oil on the shift shaft.

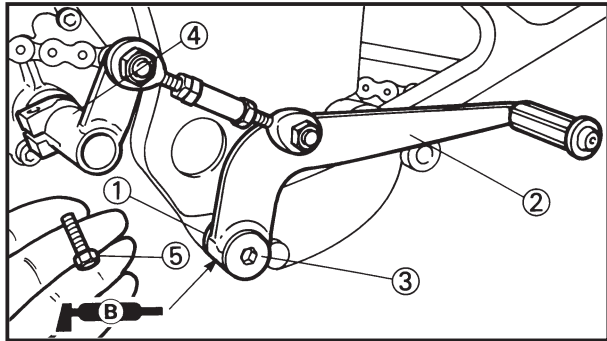

2. Install:

- Plain washer ①
- Shift pedal ②
- Bolt (shift pedal) ③

22 Nm (2.2 m•kg, 16 ft•lb)

- Shift arm ④
- Bolt (shift arm) ⑤

14 Nm (1.4 m•kg, 10 ft•lb)

NOTE:

- Make sure that the joint rod distance (a) is 72.5~74.5 mm (2.85~2.93 in).
- Apply the lithium soap base grease on the bolt (shift pedal).
- Install the shift arm so that the shift pedal is highest with the distance (b) between the shift pedal outer diameter and the bottom end of the footrest bracket being 17mm (0.67 in) or more.

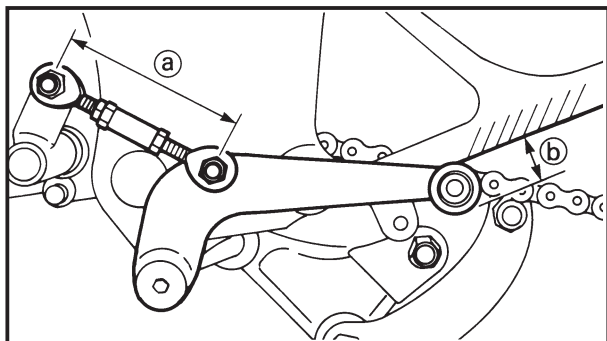



EC4H0000

TRANSMISSION, SHIFT CAM AND SHIFT FORK

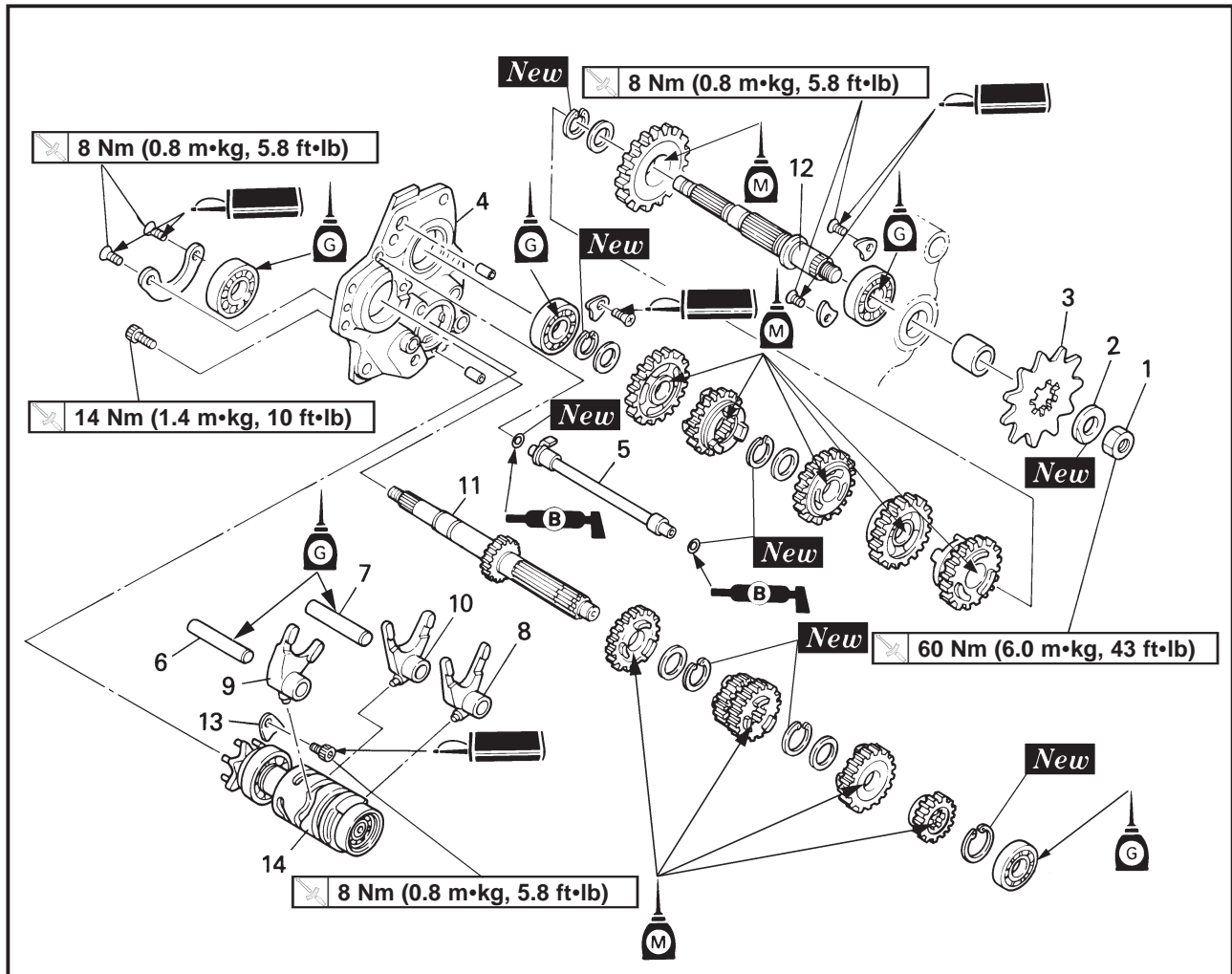

Extend of removal	Order	Part name	Q'ty	Remarks
Preparation for removal		TRANSMISSION, SHIFT CAM AND SHIFT FORK REMOVAL		
		Lower cowl		Refer to "COWLING, SEAT AND FUEL TANK" section.
		Exhaust pipe		Refer to "EXHAUST PIPE AND SILENCER" section.
		Clutch Drain the transmission oil.		Refer to "CLUTCH" section. Refer to "TRANSMISSION OIL REPLACEMENT" section in the CHAPTER 3.
		Crankcase cover (right)		Refer to "PRIMARY DRIVEN GEAR, PRIMARY DRIVE GEAR AND BALANCER SHAFT" section.
		Shift shaft and stopper lever Oil pump driven gear		} Refer to "SHIFT SHAFT AND OIL PUMP" section.

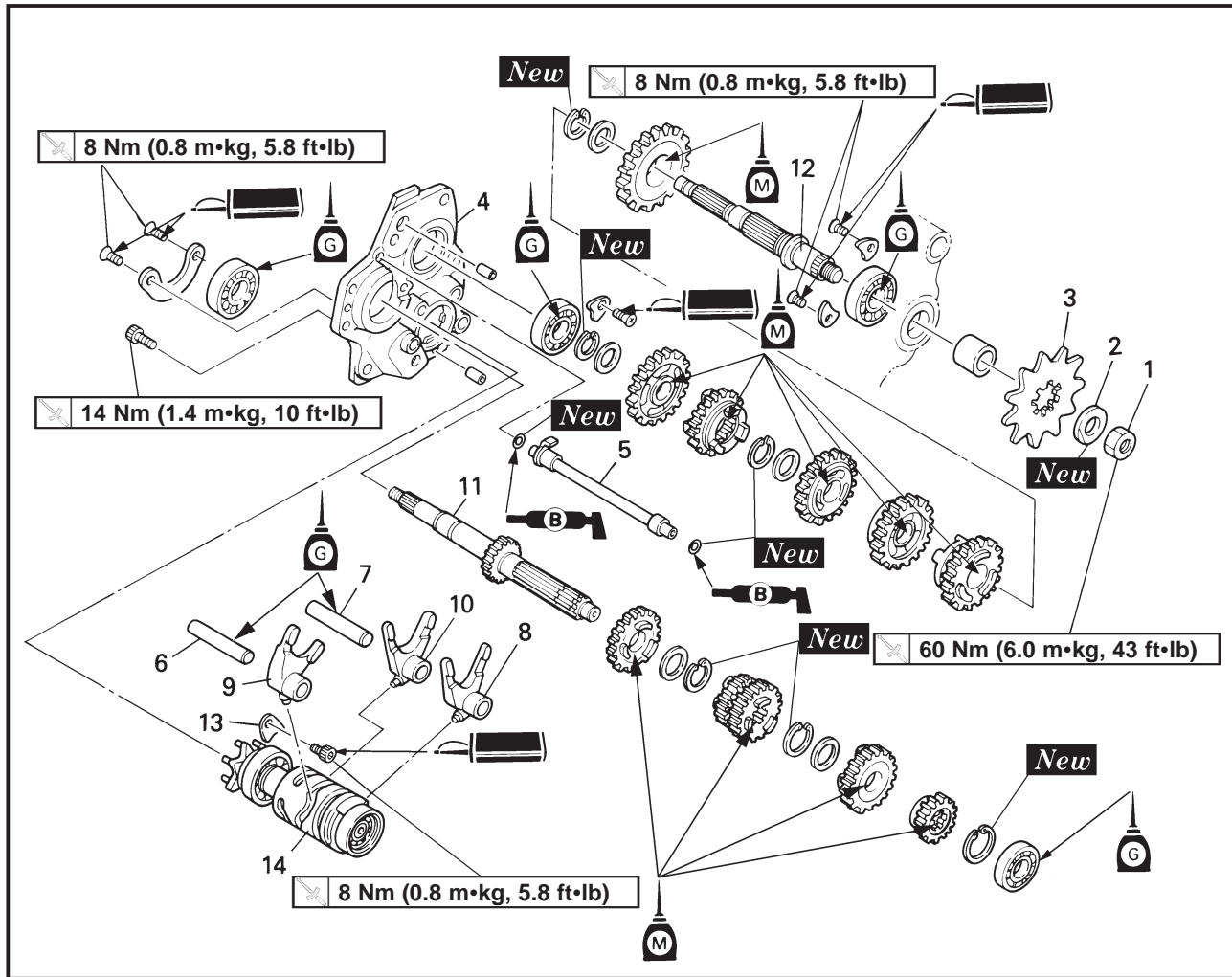

- Extend of removal: ① Oil delivery pipe removal
 ② Shift cam and shift fork removal
 ③ Main axle and drive axle removal

Extend of removal	Order	Part name	Q'ty	Remarks
	1	Nut (drive sprocket)	1	} Refer to "REMOVAL POINTS".
	2	Lock washer	1	
	3	Drive sprocket	1	
① ↓	4	Transmission housing	1	} Refer to "REMOVAL POINTS".
② ↓	5	Oil delivery pipe	1	
③ ↓	6	Guide bar (short)	1	
	7	Guide bar (long)	1	
	8	Shift fork 1	1	
	9	Shift fork 2	1	
	10	Shift fork 3	1	
	11	Main axle	1	} Refer to "REMOVAL POINTS".
② ↓	12	Drive axle	1	
	13	Bearing plate cover	2	} Refer to "REMOVAL POINTS".
③ ↓	14	Shift cam	1	

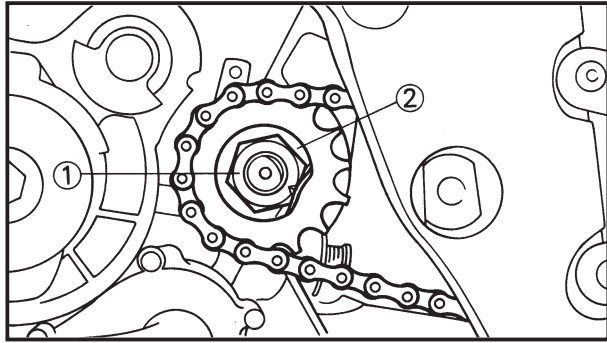

EC4H3000

REMOVAL POINTS

EC4F3100

Drive sprocket

- Remove:
 - Nut (drive sprocket) ①
 - Lock washer ②

NOTE:

- Straighten the lock washer tab.
- Loosen the nut while applying the rear brake.

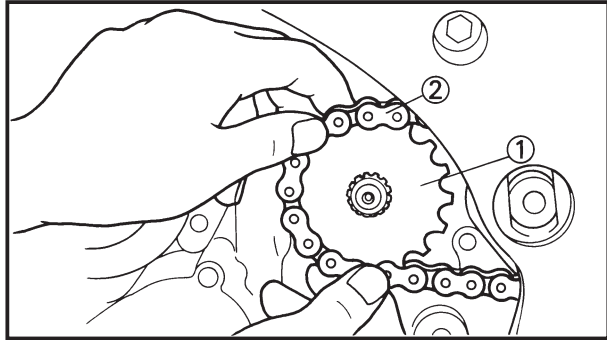

- Remove:
 - Drive sprocket ①
 - Drive chain ②

NOTE:

Remove the drive sprocket together with the drive chain.

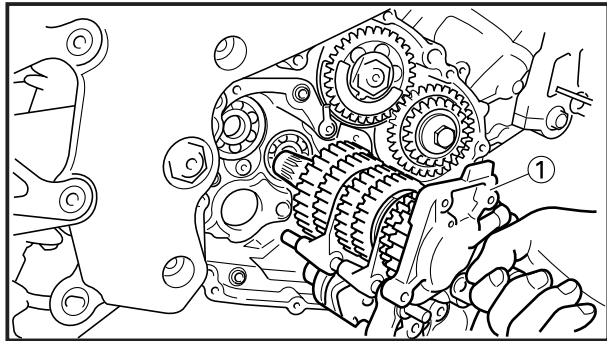

EC4H3100

Transmission housing

- Remove:
 - Bolt (transmission housing)
 - Transmission housing ①

NOTE:

Remove the transmission housing together with the transmission, shift cam and shift fork.

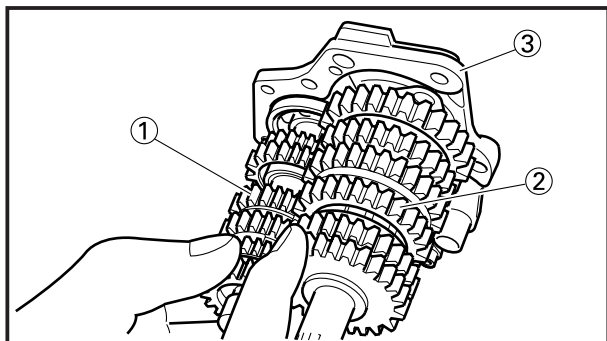

EC4H3210

Transmission

- Remove:
 - Main axle ①
 - Drive axle ②

NOTE:

- Remove the main axle together with the drive axle from the transmission housing ③.
- Remove assembly carefully. Note the position of each part. Pay particular attention to the location and direction of shift forks.

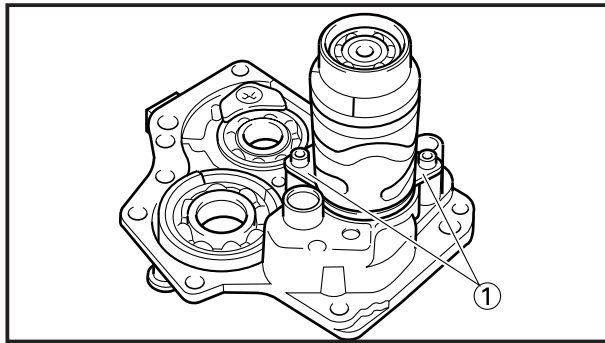

EC4H3300

Shift cam

1. Remove:
 - Bearing plate cover ①

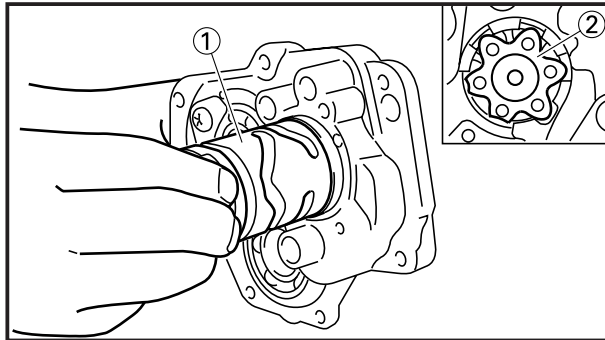

2. Remove:
 - Shift cam ①

NOTE:

Turn the segment ② to the position shown in the figure so that it does not contact the transmission housing.

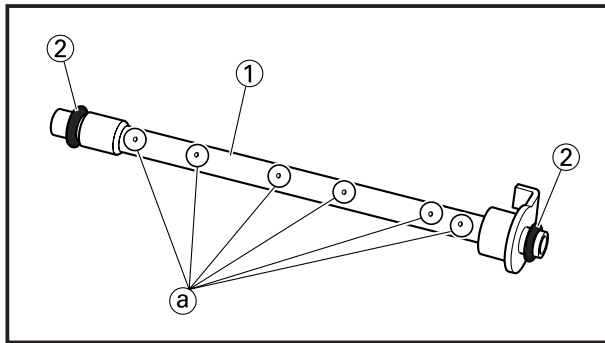

EC4H4000

INSPECTION

EC4H4100

Oil delivery pipe

1. Inspect:
 - Oil delivery pipe ①
 - O-ring ②
 - Damage → Replace.
 - Oil orifice (a)
 - Clogged → Blow.

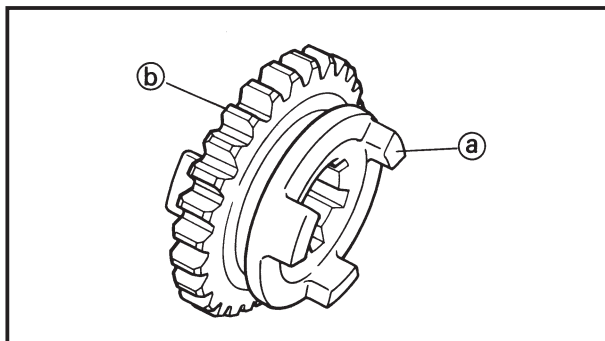

EC4H4210

Gears

1. Inspect:
 - Matching dog (a)
 - Gear teeth (b)
 - Wear/Damage → Replace.

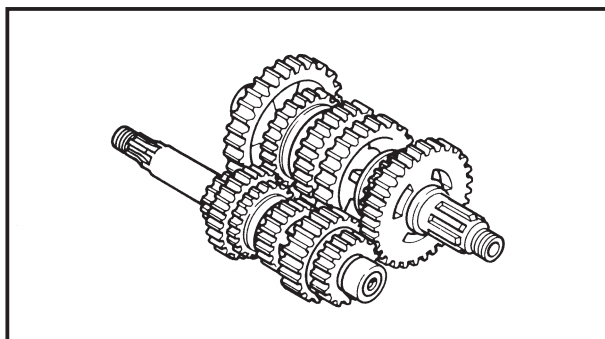

2. Check:
 - Gears movement
 - Unsmooth movement → Repair or replace.

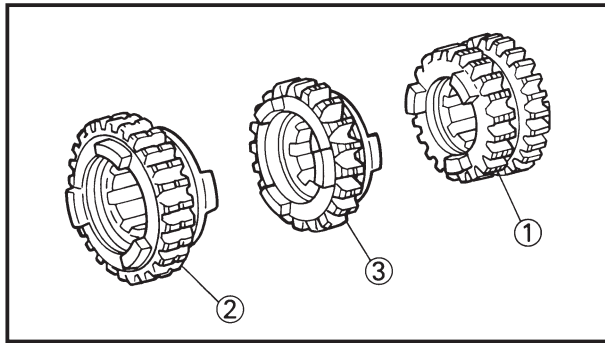

EC4H4300

Shift fork groove

1. Measure:

- 3rd/4th pinion gear ①
- 5th wheel gear ②
- 6th wheel gear ③
- Shift fork groove ④

Out of specification → Replace.



Shift fork groove ④:

Standard	<Limit>
5.05~5.18 mm (0.199~0.204 in)	5.35 mm (0.211 in)

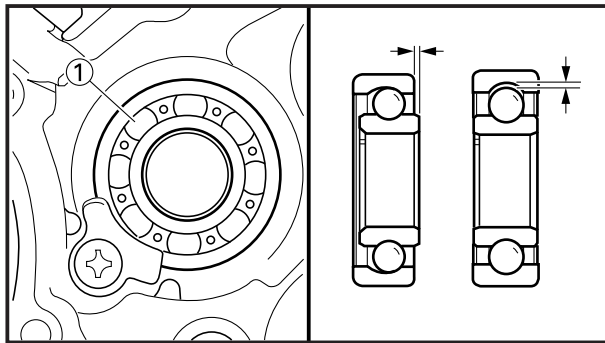
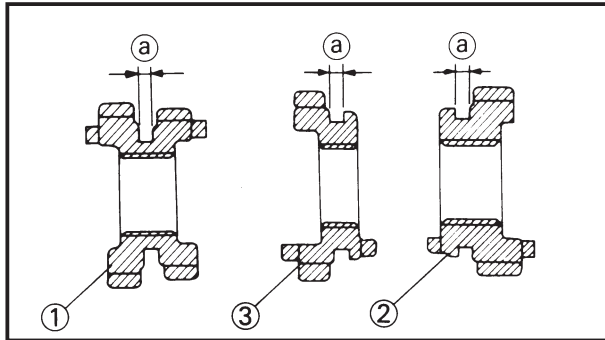

EC4H4600

Bearing

1. Inspect:

- Bearing ①
- Rotate inner race with a finger.
Rough spot/Seizure → Replace.

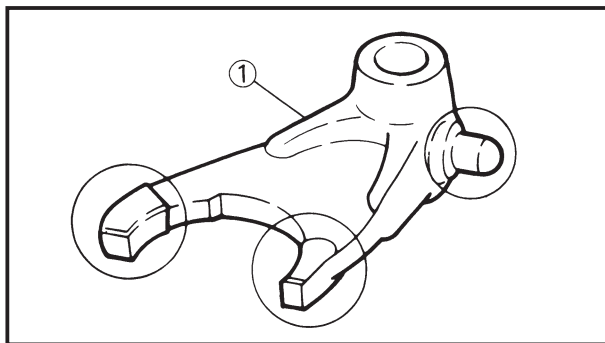

EC4H4701

Shift fork and shift cam

1. Inspect:

- Shift fork ①
- Wear/Damage/Scratches → Replace.

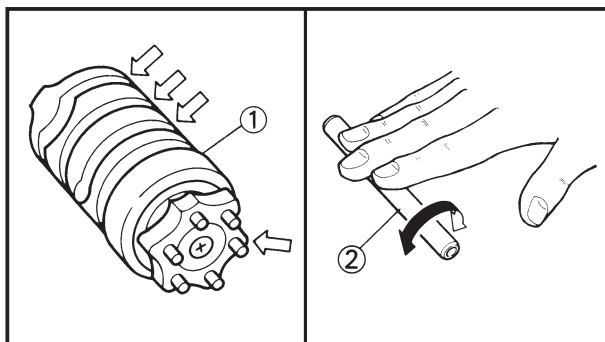

2. Inspect:

- Shift cam ①
 - Guide bar ②
- Bend/Wear/Damage → Replace.

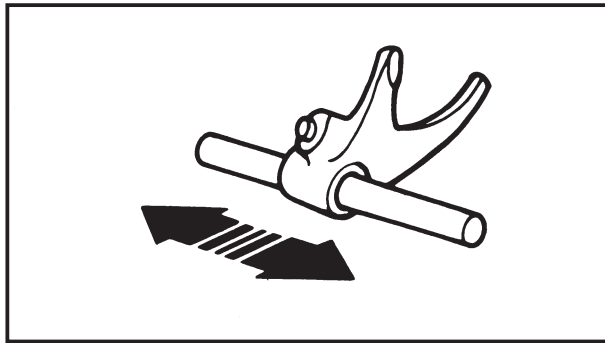

3. Check:

- Shift fork movement
On its guide bar.

Unsmooth operation → Replace shift fork and/or guide bar.

NOTE:

For a malfunctioning shift fork, replace not only the shift fork itself but the two gears each adjacent to the shift fork.

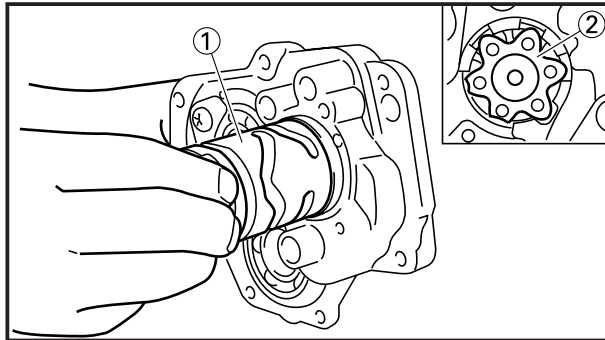

EC4H5000

ASSEMBLY AND INSTALLATION

EC4H5100

Shift cam

1. Install:

- Shift cam ①

NOTE:

Turn the segment ② to the position shown in the figure so that it does not contact the transmission housing.

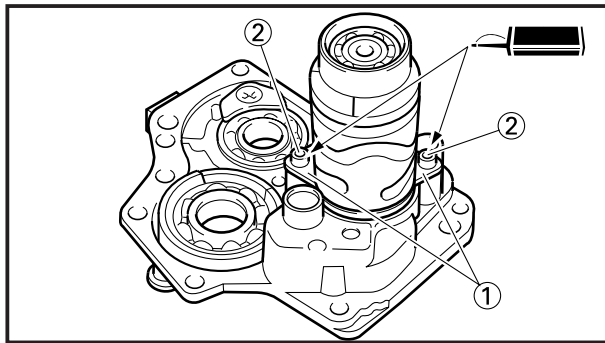

2. Install:

- Bearing plate cover ①
- Bolt (bearing plate cover) ②

8 Nm (0.8 m•kg, 5.8 ft•lb)

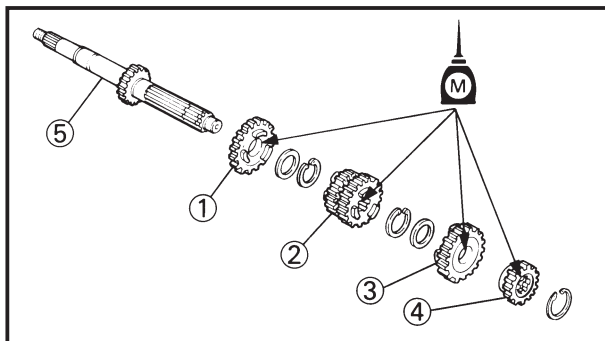

EC4H5221

Transmission

1. Install:

- 6th pinion gear (24 T) ①
- 3rd pinion gear (17/20 T) ②
- 5th pinion gear (21 T) ③
- 2nd pinion gear (19 T) ④

To main axle ⑤.

NOTE:

Apply the molybdenum disulfide oil on the gears inner circumference.

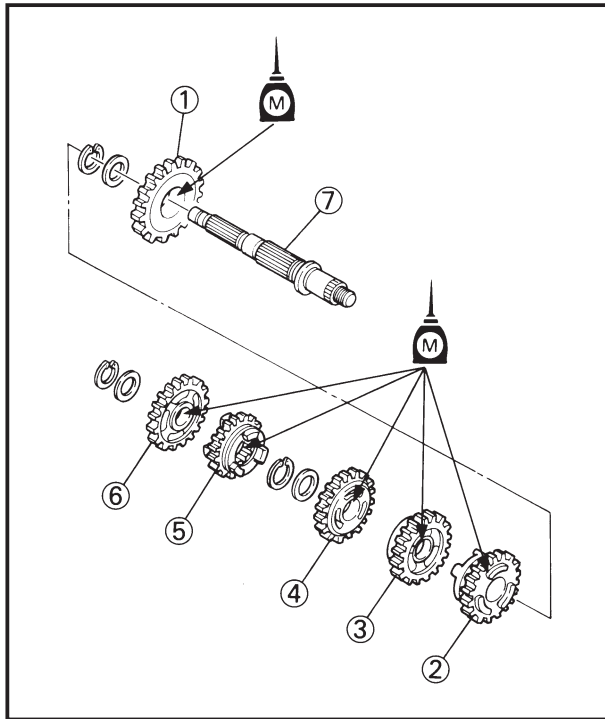

2. Install:

- 2nd wheel gear (31 T) ①
 - 5th wheel gear (24 T) ②
 - 4th wheel gear (25 T) ③
 - 3rd wheel gear (24 T) ④
 - 6th wheel gear (26 T) ⑤
 - 1st wheel gear (30 T) ⑥
- To drive axle ⑦.

NOTE:

Apply the molybdenum disulfide oil on the gears inner circumference.

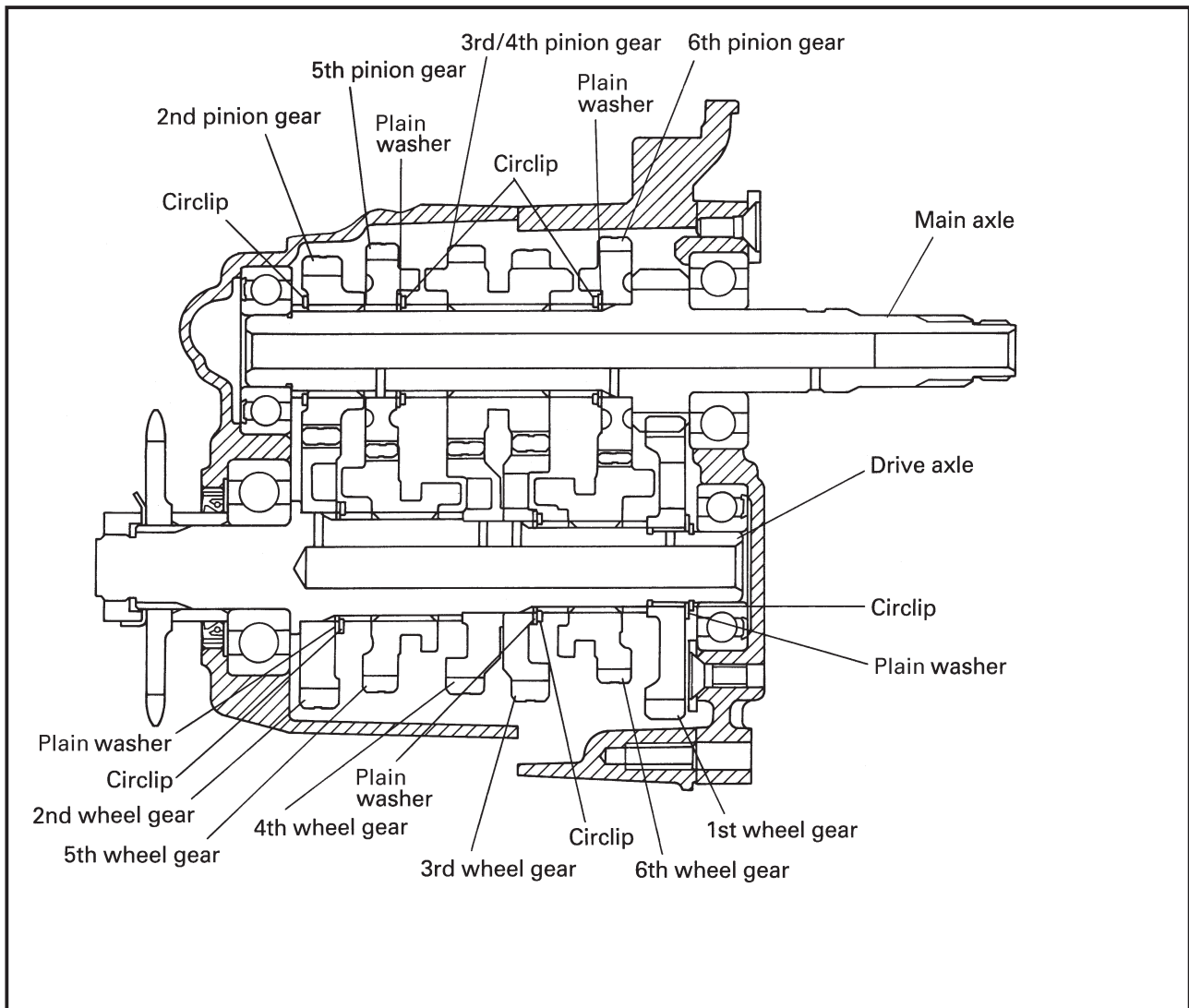

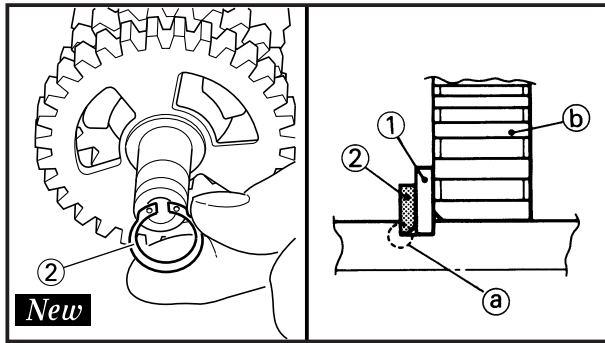

3. Install:
- Plain washer ①
 - Circlip ② **New**

NOTE:

- Be sure the circlip sharp-edged corner (a) is positioned opposite to the plain washer and gear (b).
- Be sure the circlip end (c) is positioned at axle spline groove (d).

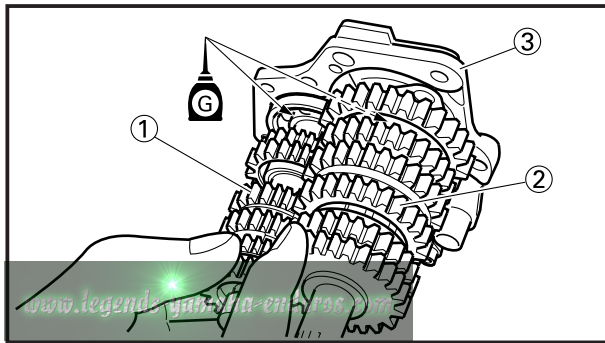
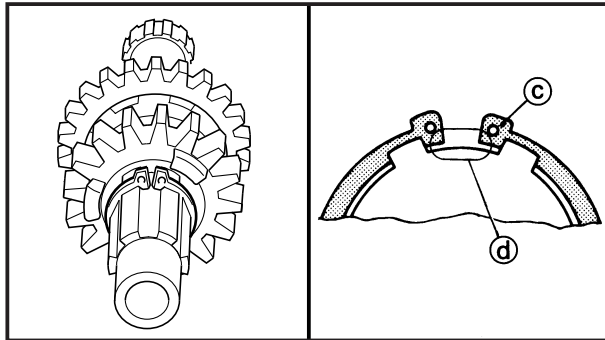

4. Install:
- Main axle ①
 - Drive axle ②

NOTE:

- Apply the transmission oil on the main axle and drive axle bearings.
- Install the main axle together with the drive axle into the transmission housing ③.

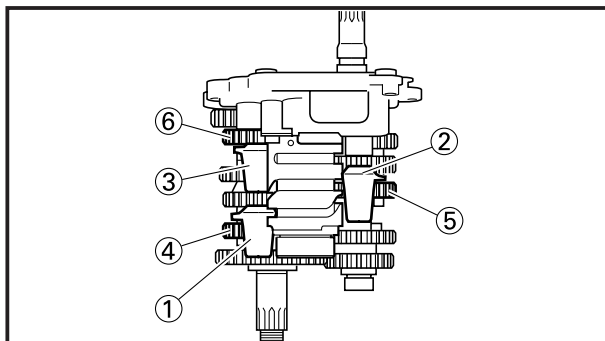

5. Install:
- Shift fork 1 ①
 - Shift fork 2 ②
 - Shift fork 3 ③

NOTE:

- Mesh the shift fork #1 with the 5th wheel gear ④ and #3 with the 6th gear ⑥ on the drive axle.
- Mesh the shift fork #2 with the 3rd/4th pinion gear ⑤ on the main axle.

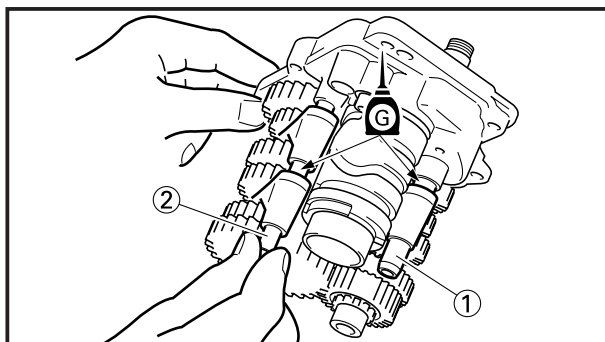

6. Install:
- Guide bar (short) ①
 - Guide bar (long) ②

NOTE:

- Apply the transmission oil on the guide bars.
- Be sure the short bar is inserted into the shift fork #2 and the long one into #1 and #3.

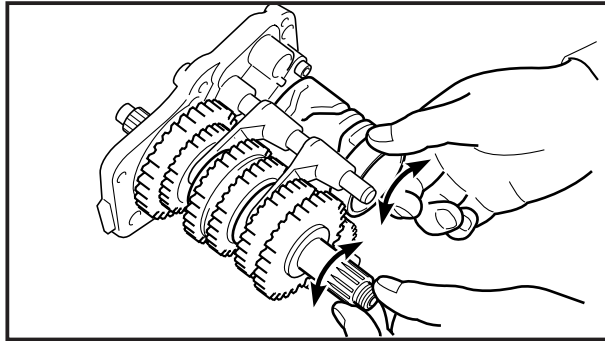

7. Check:
- Shift operation
 - Transmission operation
- Unsmooth operation → Repair.

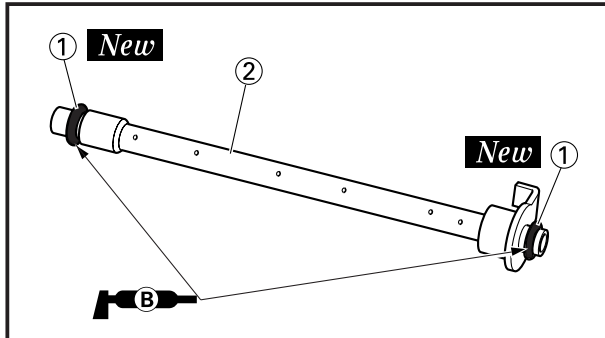

8. Install:
- O-ring ① **New**
 - To oil delivery pipe ②.

NOTE: _____
 Apply the lithium soap base grease on the O-rings.

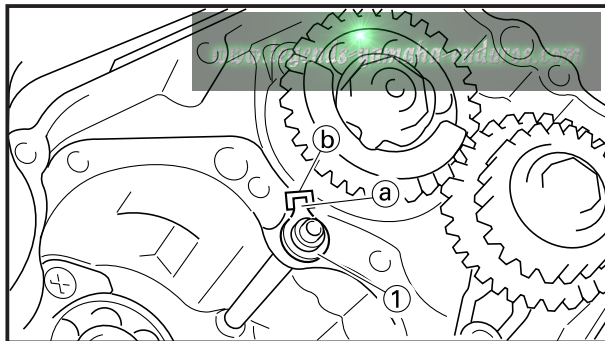

9. Install:
- Oil delivery pipe ①

NOTE: _____
 When installing the oil delivery pipe, fit the projection ① of the oil delivery pipe into the hole ② on the crankcase.

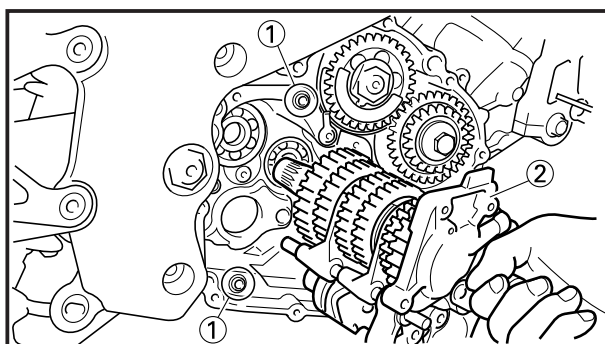

10. Install:
- Dowel pin ①
 - Transmission housing ②

NOTE: _____
 • Apply the lithium soap base grease on the crankcase oil seal lip.
 • When installing the drive axle into the crankcase, pay careful attention to the crankcase oil seal lip.

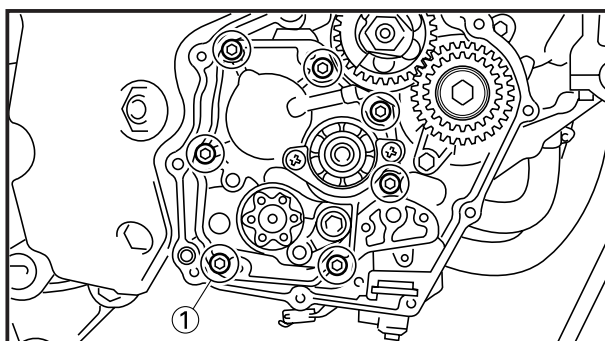

11. Install:
- Bolt (transmission housing) ①
- 14 Nm (1.4 m•kg, 10 ft•lb)**

NOTE: _____
 Tighten the bolts in stages, using a crisscross pattern.

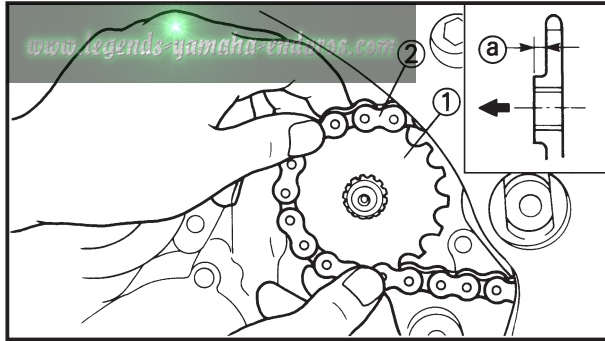

EC4F5500

Drive sprocket

1. Install:
 - Drive sprocket ①
 - Drive chain ②

NOTE: _____

- Install the drive sprocket with its stepped portion ① facing the engine.
- Install the drive sprocket together with the drive chain.

2. Install:
 - Lock washer ① **New**
 - Nut (drive sprocket) ②

60 Nm (6.0 m•kg, 43 ft•lb)

NOTE: _____

Tighten the nut while applying the rear brake.

3. Bend the lock washer tab to lock the nut.



EC4L0000

CDI MAGNETO

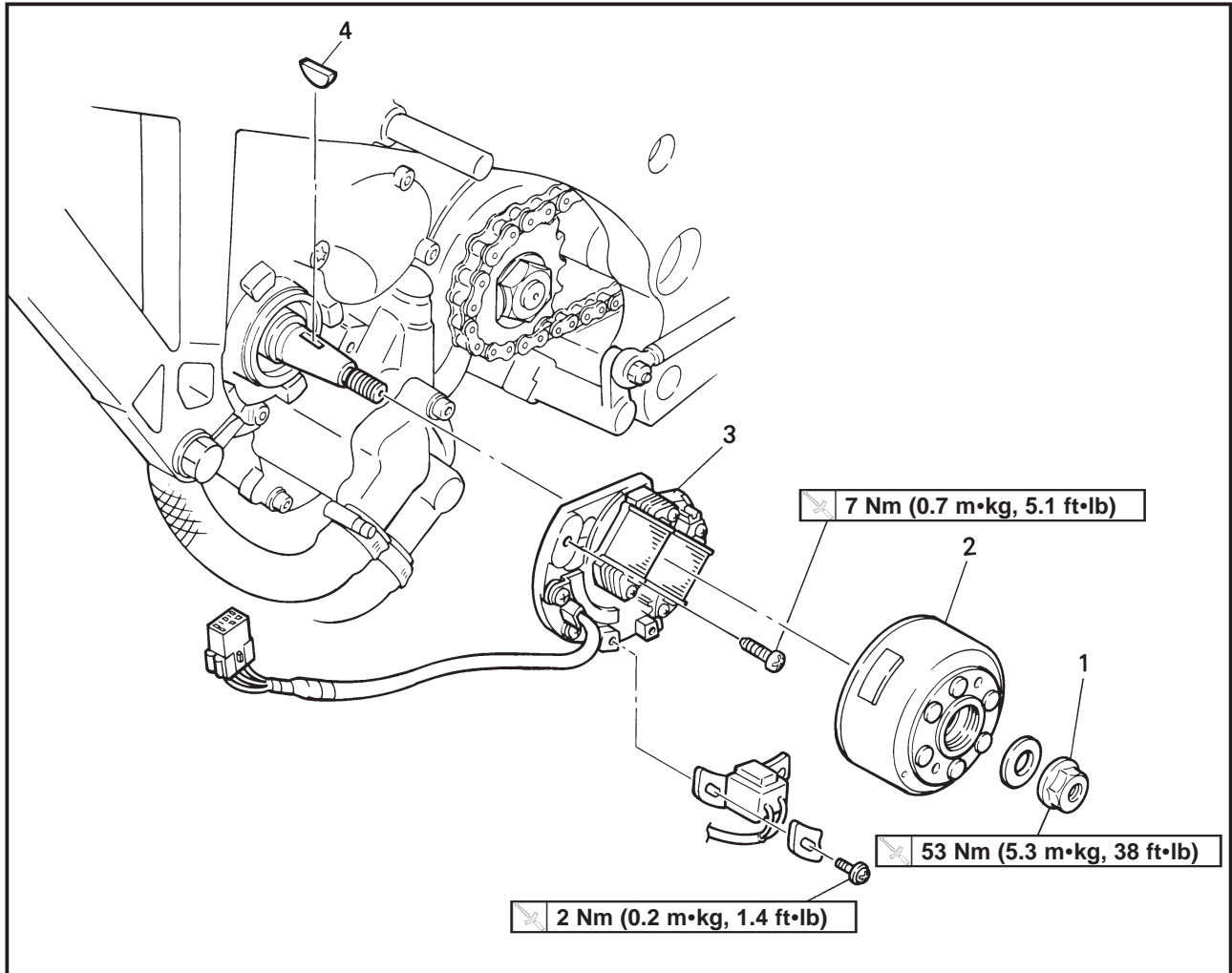

Extend of removal: ① CDI magneto removal

Extend of removal	Order	Part name	Q'ty	Remarks
Preparation for removal		CDI MAGNETO REMOVAL Cowling and fuel tank		Refer to "COWLING, SEAT AND FUEL TANK" section.
		Disconnect the CDI magneto lead.		
<div style="text-align: center;"> ↑ ① ↓ </div>	1	Nut (rotor)	1	} Use special tool. } Refer to "REMOVAL POINTS".
	2	Rotor	1	
	3	Stator	1	
	4	Woodruff key	1	

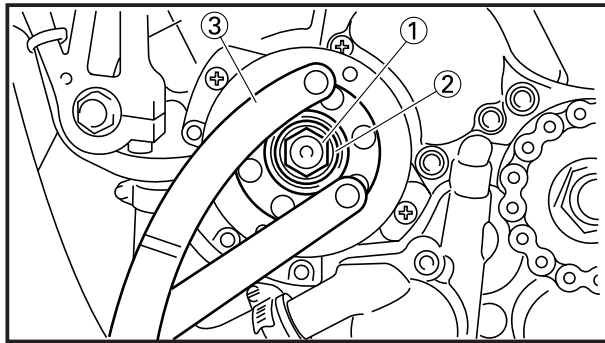

EC4L3000

REMOVAL POINTS

EC4L3101

Rotor

1. Remove:
 - Nut (rotor) ①
 - Plain washer ②
 Use the rotor holding tool ③.



Rotor holding tool:
YU-01235/90890-01235

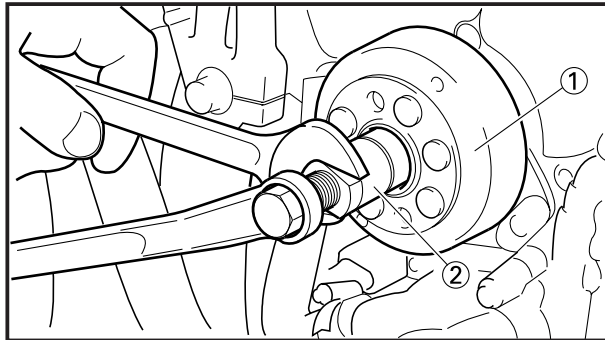

2. Remove:
 - Rotor ①
 Use the flywheel puller ②.



Flywheel puller:
YM-01189/90890-01189

NOTE:

When installing the flywheel puller, turn it counterclockwise.

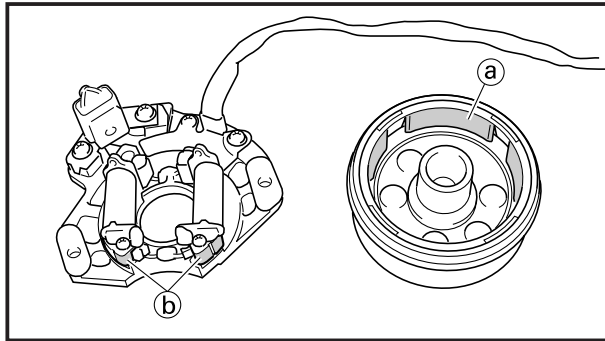

EC4L4000

INSPECTION

EC4L4101

CDI magneto

1. Inspect:
 - Rotor inner surface a
 - Stator outer surface b
 Damage → Inspect the crankshaft runout and crankshaft bearing.
 If necessary, replace CDI magneto and/or stator.

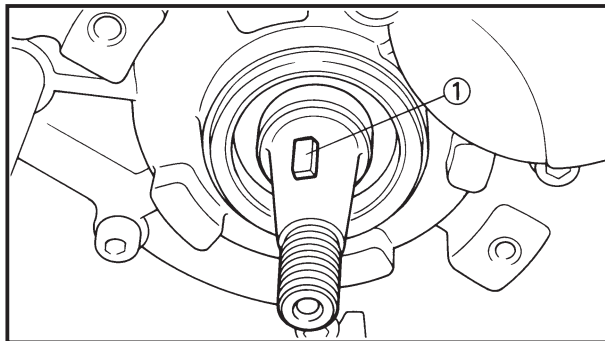

EC4L4200

Woodruff key

1. Inspect:
 - Woodruff key ①
 Damage → Replace.

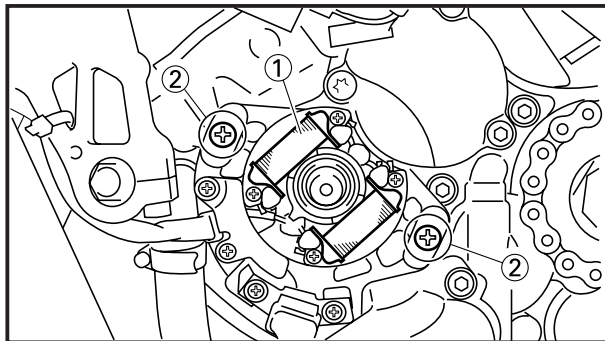

EC4L5000

ASSEMBLY AND INSTALLATION

EC4L5144

CDI magneto

1. Install:
 - Stator ①
 - Screw (stator) ②

7 Nm (0.7 m•kg, 5.1 ft•lb)

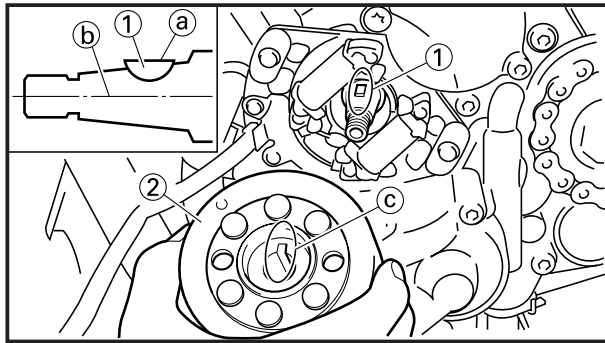

2. Install:
- Woodruff key ①
 - Rotor ②

NOTE:

- Clean the tapered portions of the crankshaft and rotor.
- When installing the woodruff key, make sure that its flat surface (a) is in parallel with the crankshaft center line (b).
- When installing the rotor, align the keyway (c) of the rotor with the woodruff key.

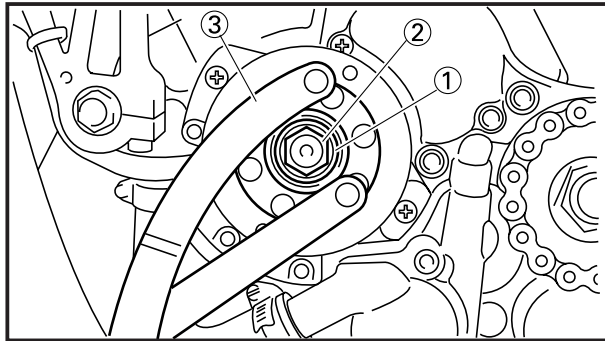

3. Install:
- Plain washer ①
 - Nut (rotor) ②

53 Nm (5.3 m•kg, 38 ft•lb)

Use the rotor holding tool ③.



**Rotor holding tool:
YU-01235/90890-01235**

4. Adjust:
- Ignition timing



**Ignition timing (B.T.D.C.):
2.3 mm (0.091 in)**

Refer to “IGNITION TIMING CHECK” section in the CHAPTER 3.

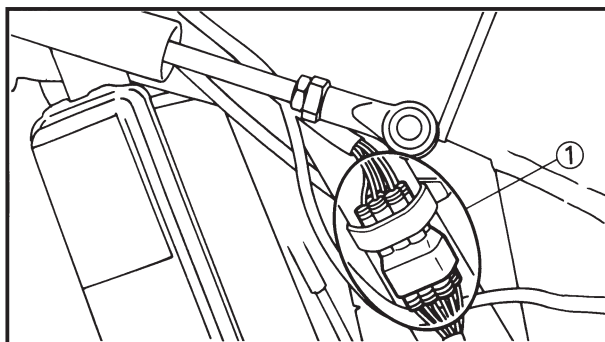

5. Connect:
- CDI magneto lead ①
- Refer to “CABLE ROUTING DIAGRAM” section in the CHAPTER 2.



EC4M0000

ENGINE REMOVAL

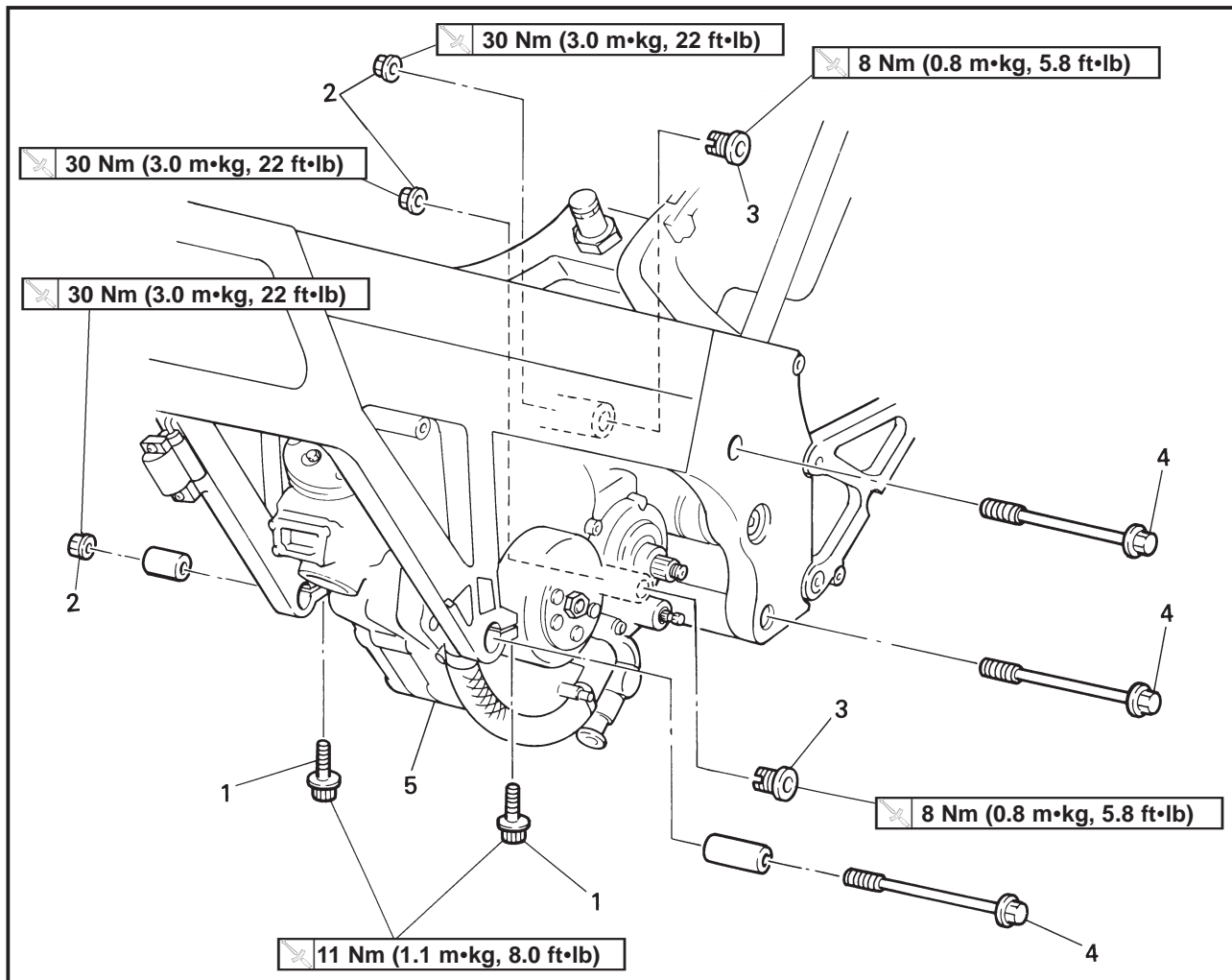

Extend of removal	Order	Part name	Q'ty	Remarks
Preparation for removal		ENGINE REMOVAL Hold the machine by placing the suitable stand. Cowling and fuel tank Carburetor and carburetor cover Exhaust pipe Clutch cable Radiator hose 2 Radiator hose 4 Shift arm Drive sprocket Spark plug cap Disconnect the CDI magneto lead.		⚠WARNING Support the machine securely so there is no danger of it falling over. Refer to "COWLING, SEAT AND FUEL TANK" section. Refer to "CARBURETOR AND REED VALVE" section. Refer to "EXHAUST PIPE AND SILENCER" section. Disconnect at engine side. Disconnect at water pump side. Disconnect at cylinder head side. Refer to "SHIFT SHAFT AND OIL PUMP" section. Refer to "TRANSMISSION, SHIFT CAM AND SHIFT FORK" section.

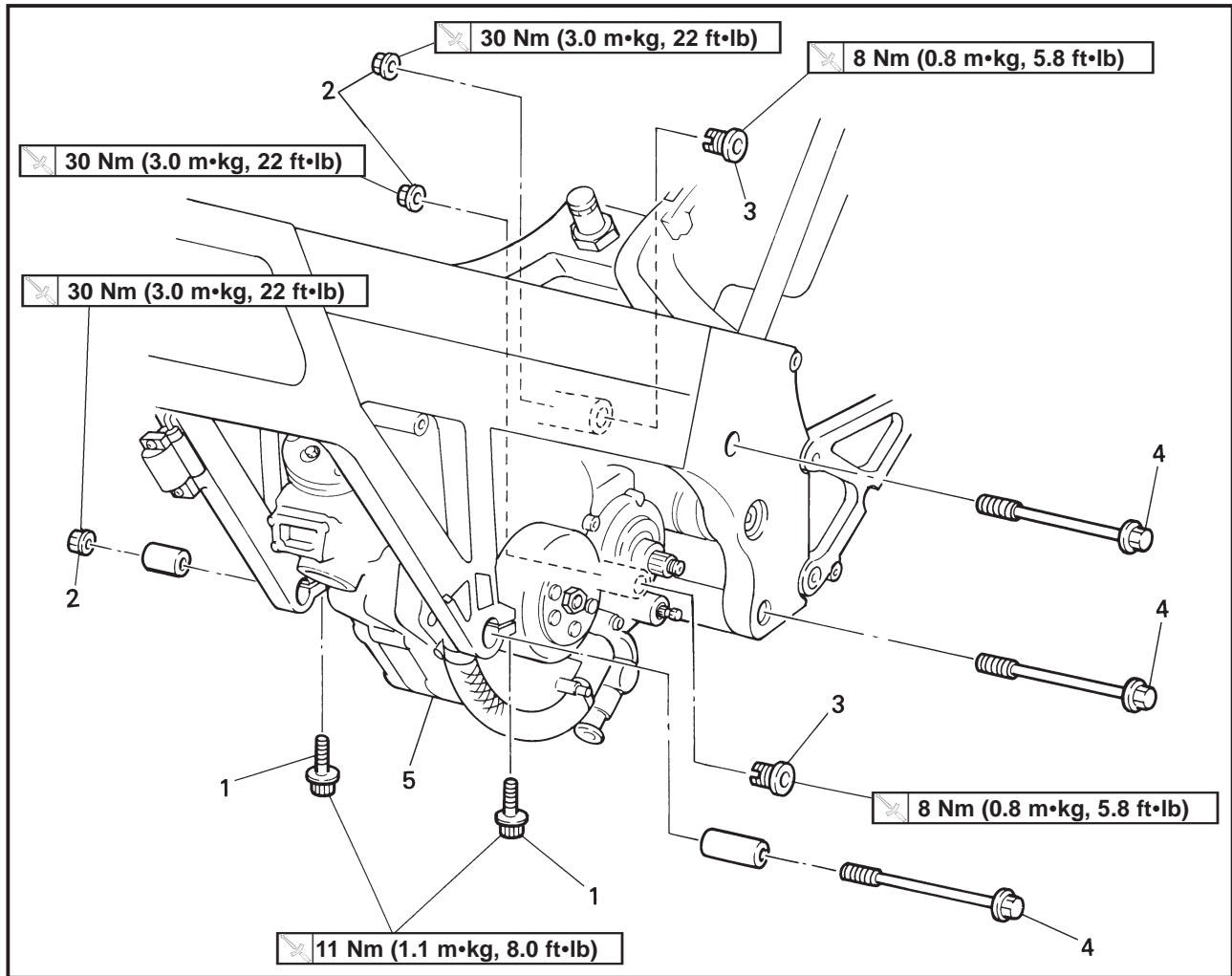

Extend of removal: ① Engine removal

Extend of removal	Order	Part name	Q'ty	Remarks
↑ ① ↓	1	Pinch bolt (engine mounting collar)	2	Only loosening. } Refer to "REMOVAL POINTS."
	2	Nut (engine mounting bolt)	3	
	3	Engine mounting adjust bolt	2	
	4	Engine mounting bolt	3	
	5	Engine	1	

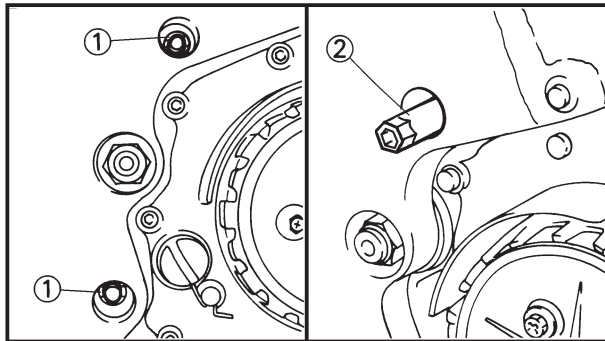

EC4M3000

REMOVAL POINTS

EC4M3331

Engine removal

1. Loosen:

- Engine mounting adjust bolt ①

NOTE:

Use the adjust bolt wrench ② to loosen the engine mounting adjust bolt.

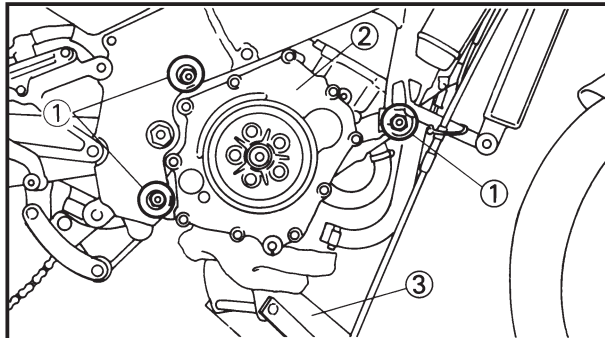

2. Remove:

- Engine mounting bolt ①
- Engine ②

NOTE:

- Before removing the engine, make sure that the couplers, hoses and cables are disconnected.
- Remove the engine by lowering it with a jack ③.

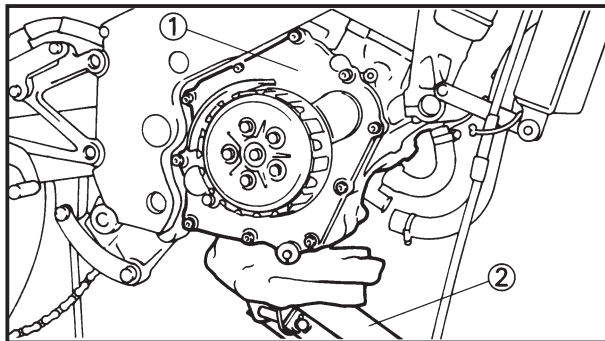

EC4M5000

ASSEMBLY AND INSTALLATION

EC4M5181

Engine installation

1. Install:

- Engine ①

NOTE:

Install the engine by raising it into the frame with a jack ②.

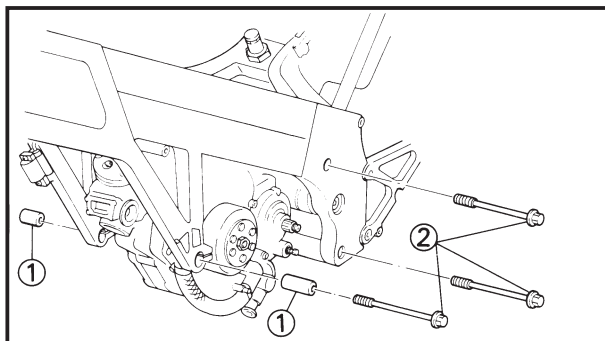

2. Install:

- Engine mounting collar ①
- Engine mounting bolt ②

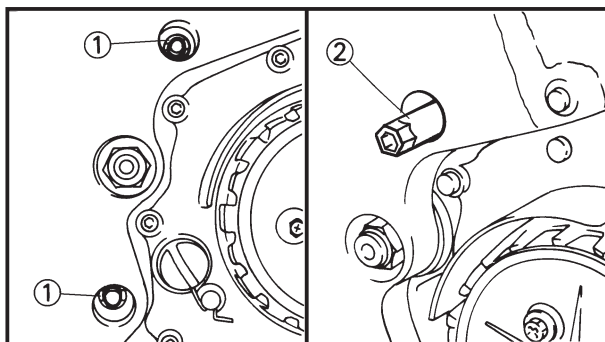

3. Tighten:

- Engine mounting adjust bolt ①

8 Nm (0.8 m•kg, 5.8 ft•lb)

NOTE:

Use the adjust bolt wrench ② to tighten the engine mounting adjust bolt.

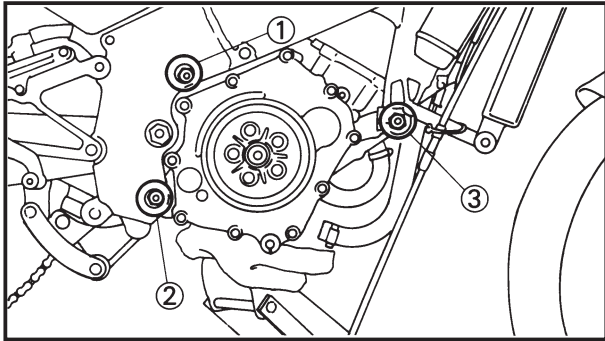

4. Install:

- Nut (engine mounting bolt) (upper) ①

 **30 Nm (3.0 m•kg, 22 ft•lb)**

- Nut (engine mounting bolt) (lower) ②

 **30 Nm (3.0 m•kg, 22 ft•lb)**

- Nut (engine mounting bolt) (front) ③

 **30 Nm (3.0 m•kg, 22 ft•lb)**

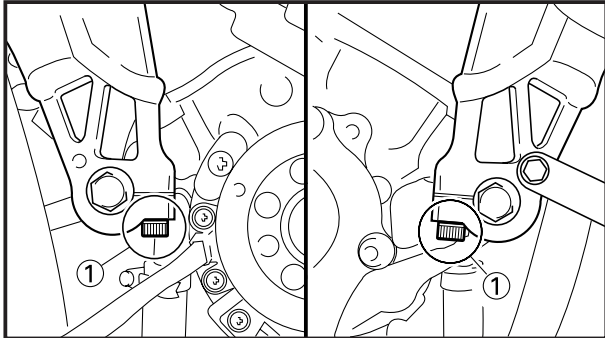

5. Tighten:

- Pinch bolt (engine mounting collar) ①

 **11 Nm (1.1 m•kg, 8.0 ft•lb)**

CAUTION:

After tightening the nuts (engine mounting bolts), tighten the pinch bolts.

CRANKCASE, CRANKSHAFT AND WATER PUMP

ENG



EC4Q0000

CRANKCASE, CRANKSHAFT AND WATER PUMP

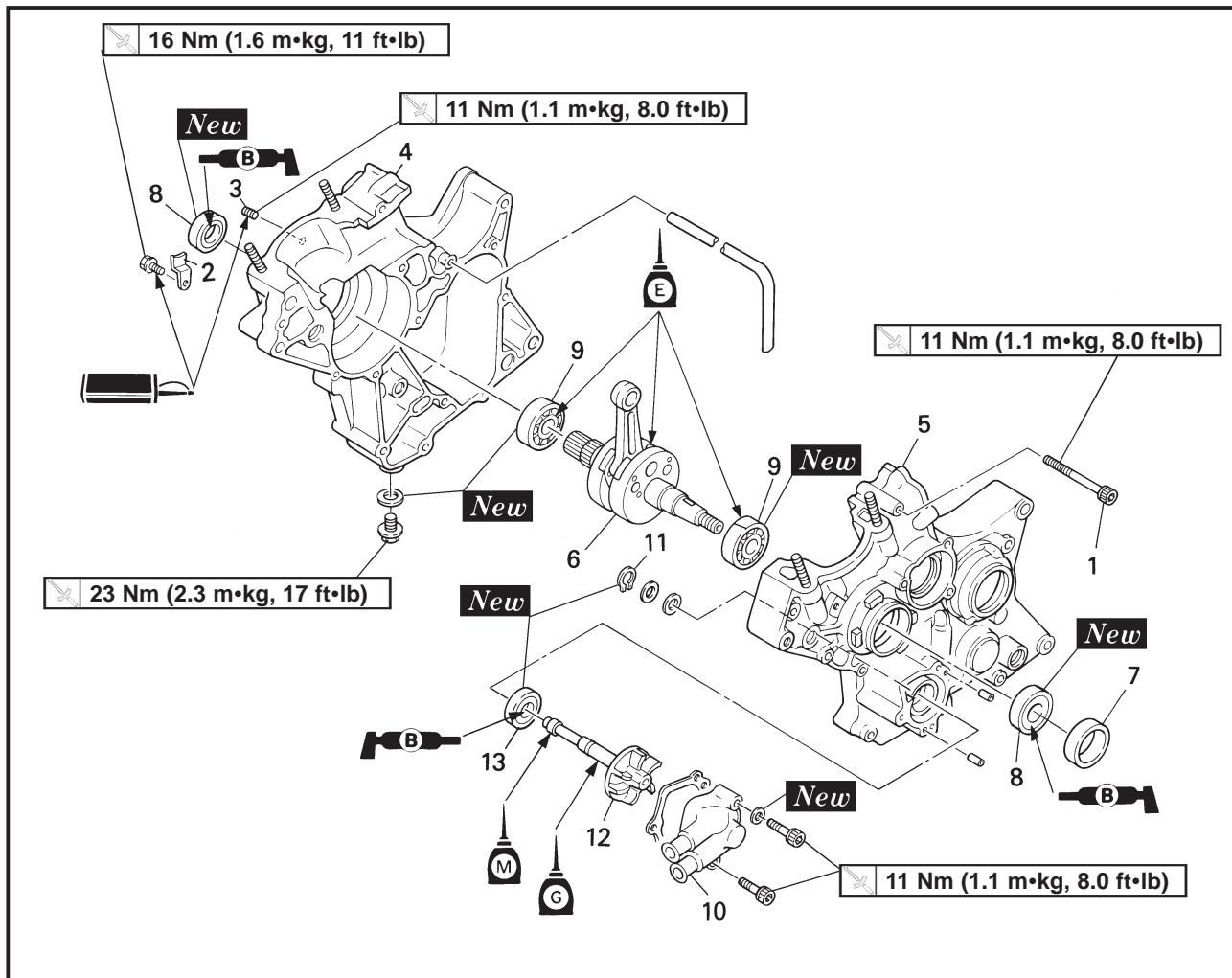

Extend of removal	Order	Part name	Q'ty	Remarks
Preparation for removal		CRANKCASE AND CRANK SHAFT REMOVAL		
		Engine		Refer to "ENGINE REMOVAL" section.
		Reed valve		Refer to "CARBURETOR AND REED VALVE" section.
		Piston		Refer to "CYLINDER HEAD, CYLINDER AND PISTON" section.
		Push lever axle		Refer to "CLUTCH" section.
		Rotor and stator		Refer to "CDI MAGNETO" section.
		Primary drive gear		Refer to "PRIMARY DRIVEN GEAR, PRIMARY DRIVE GEAR AND BALANCER SHAFT" section.
		Balancer shaft		
	Transmission		Refer to "TRANSMISSION, SHIFT CAM AND SHIFT FORK" section.	

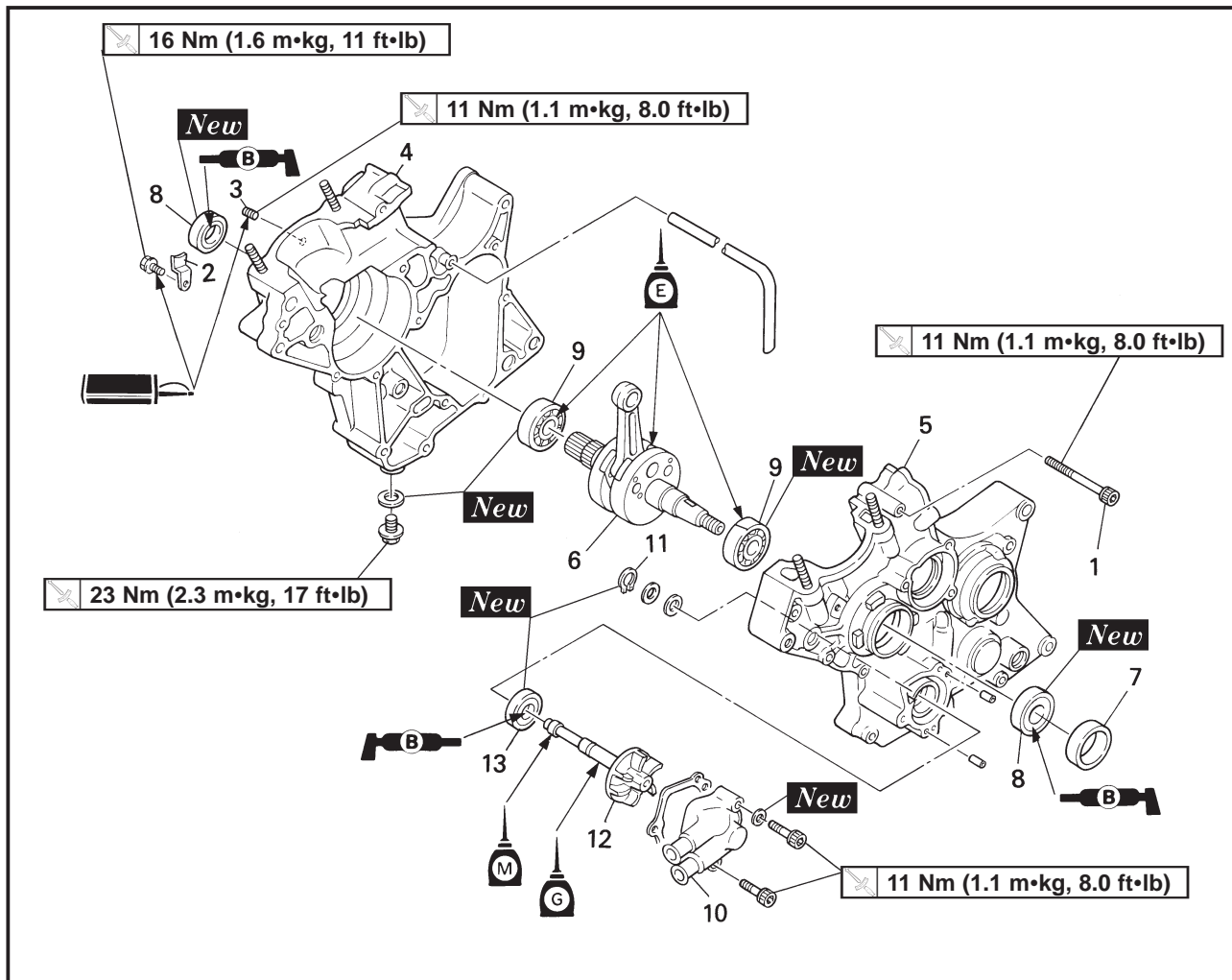

- Extend of removal:
- ① Crankcase separation
 - ② Crankshaft removal
 - ③ Crankshaft bearing removal
 - ④ Impeller shaft removal
 - ⑤ Oil seal (impeller shaft) removal

Extend of removal	Order	Part name	Q'ty	Remarks
↑ ① ↓	1	Bolt (crankcase)	13	Use special tool. Refer to "REMOVAL POINTS".
↑ ② ↓	2	Holder	1	
↑ ④ ↓	3	Blind plug	1	
↑ ⑤ ↓	4	Crankcase (right)	1	
↑ ③ ↓	5	Crankcase (left)	1	
	6	Crankshaft	1	Use special tool. Refer to "REMOVAL POINTS".
	7	Spacer	1	
	8	Oil seal (crankshaft)	2	
	9	Bearing	2	Refer to "REMOVAL POINTS".
	10	Water pump housing cover	1	
	11	Circlip	1	
	12	Impeller shaft	1	
↑ ④ ↓	13	Oil seal (impeller shaft)	1	Refer to "REMOVAL POINTS".

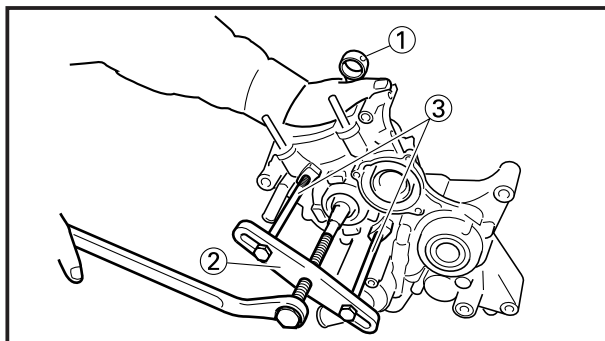
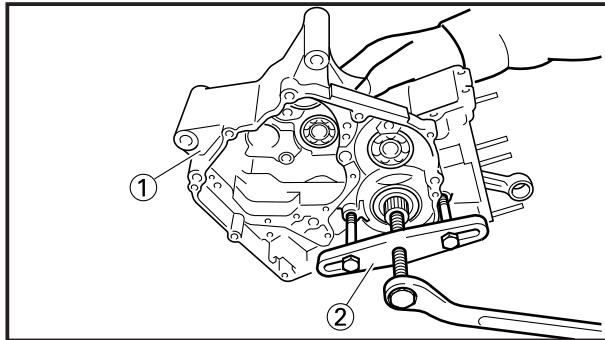
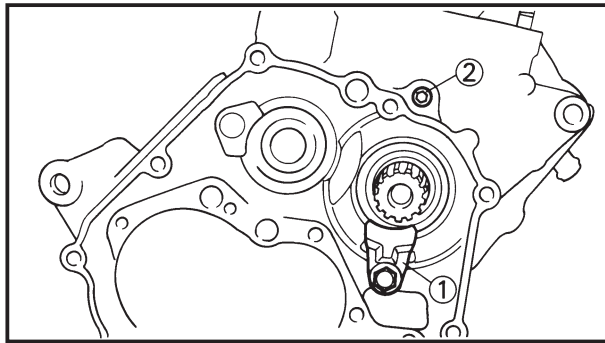

EC4Q3000

REMOVAL POINTS

EC4Q3100

Crankcase

1. Remove:

- Holder ①
- Blind plug ②

2. Remove:

- Crankcase (right) ①
- Use the crankcase separating tool ②.



Crankcase separating tool:
YU-01135-A/90890-01135

NOTE:

- Fully tighten the tool holding bolts, but make sure the tool body is parallel with the case. If necessary, one screw may be backed out slightly to level tool body.
- As pressure is applied, alternately tap on the front engine mounting boss and rear engine mounting boss.

CAUTION:

Use soft hammer to tap on the case half. Tap only on reinforced portions of case. Do not tap on gasket mating surface. Work slowly and carefully. Make sure the case halves separate evenly. If one end “hangs up”, take pressure off the push screw, realign, and start over. If the cases do not separate, check for a remaining case screw or fitting. Do not force.

EC4N3300

Crankshaft

1. Remove:

- Crankshaft ①
- Use the crankcase separating tool ② and crankcase separating bolt ③.



Crankcase separating tool:
YU-01135-A/90890-01135

Crankcase separating bolt:
YM-01305/90890-01305

CAUTION:

Do not use a hammer to drive out the crankshaft.

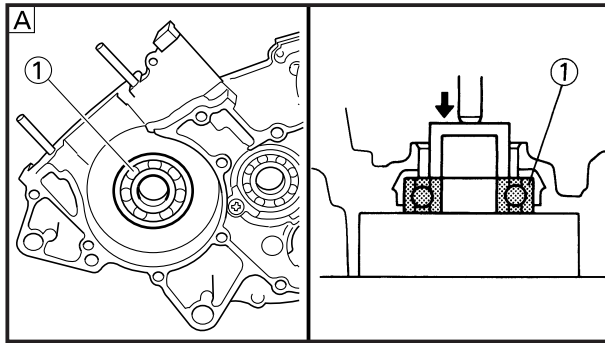

EC4N3401

Crankshaft bearing

1. Remove:
 - Bearing ①

NOTE:

- Remove the bearing from the crankcase by pressing its inner race as shown in [A].
- If the bearing is removed together with the crankshaft, remove the bearing using a general bearing puller ② as shown in [B].
- Do not use the removed bearing.

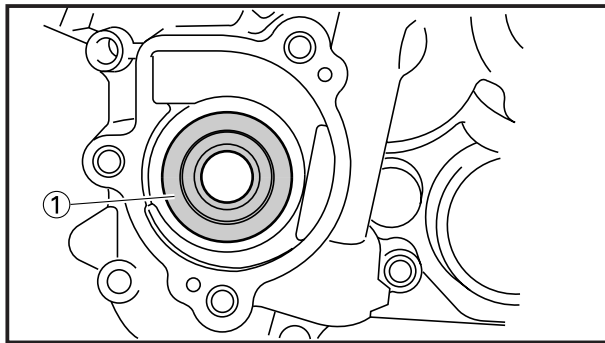
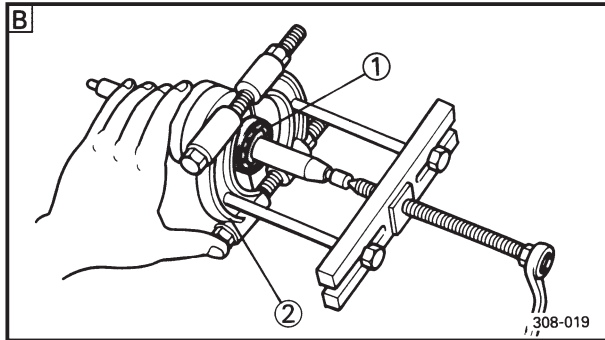

EC4Q3300

Oil seal

NOTE:

It is not necessary to disassemble the water pump, unless there is no abnormality such as excessive change in coolant level, discoloration of coolant, or milky transmission oil.

1. Remove:
 - Oil seal ①

From crankcase (right).

EC4Q4000

INSPECTION

EC4N4101

Crankcase

1. Inspect:
 - Contacting surface (a)
Scratches → Replace.
 - Engine mounting boss (b), crankcase
Cracks/Damage → Replace.

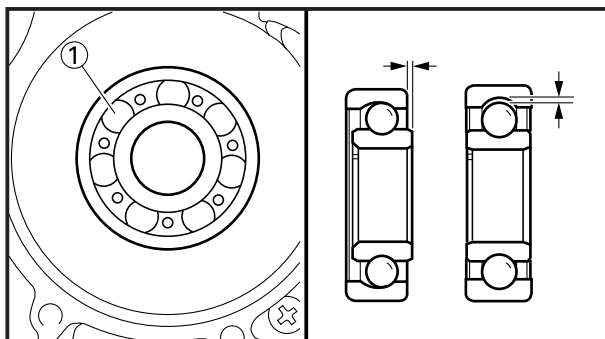
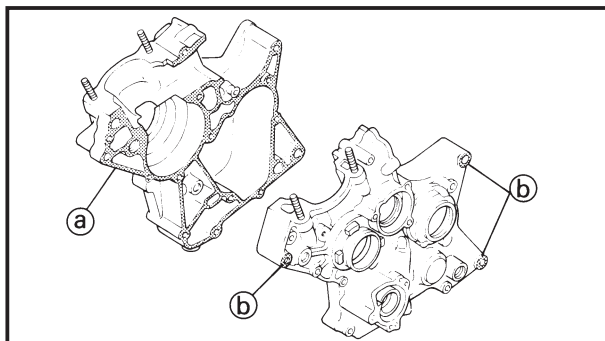

2. Inspect:
 - Bearings ①
Rotate inner race with a finger.
Rough spot/Seizure → Replace.

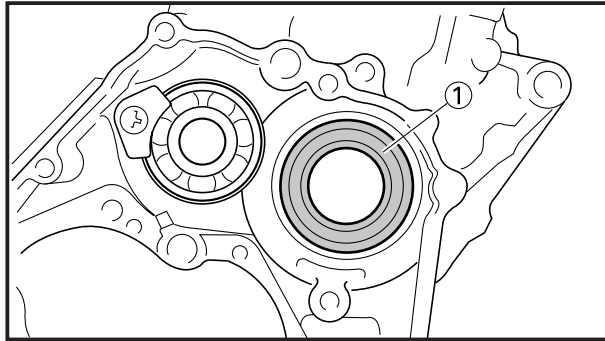

3. Inspect:
 - Oil seal ①
 Damage → Replace.

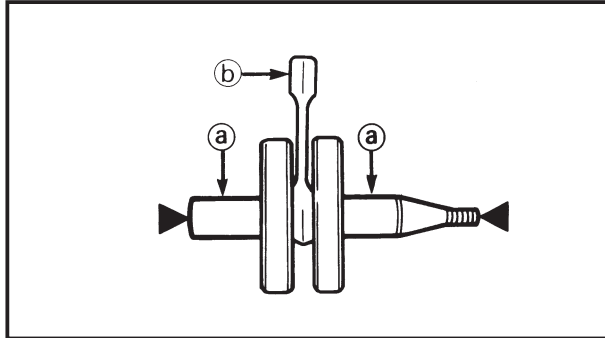

EC4N4201

Crankshaft

1. Measure:
 - Runout limit ①
 - Small end free play limit ②
 - Connecting rod big end side clearance ③
 - Crank width ④
 Out of specification → Replace.
 Use the dial gauge and a thickness gauge.

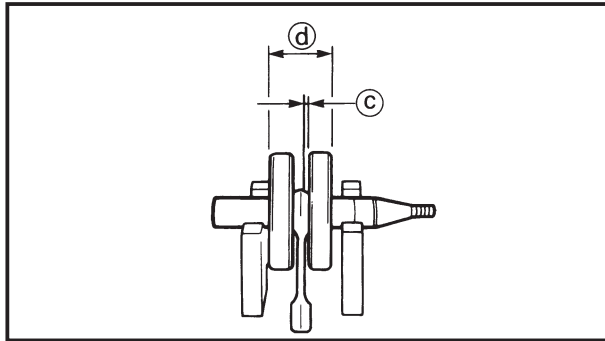

Dial gauge:

YU-03097/90890-01252

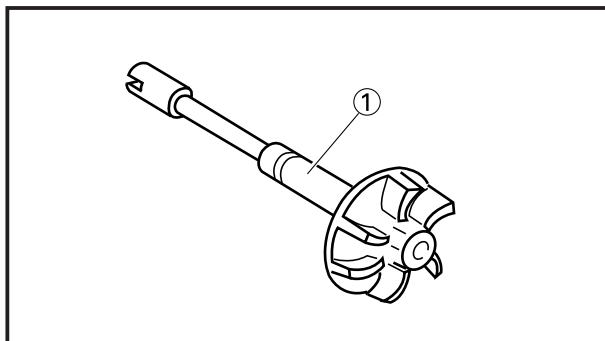

EC444200

Impeller shaft

1. Inspect:
 - Impeller shaft ①
 Bend/Wear/Damage → Replace.
 Fur deposits → Clean.

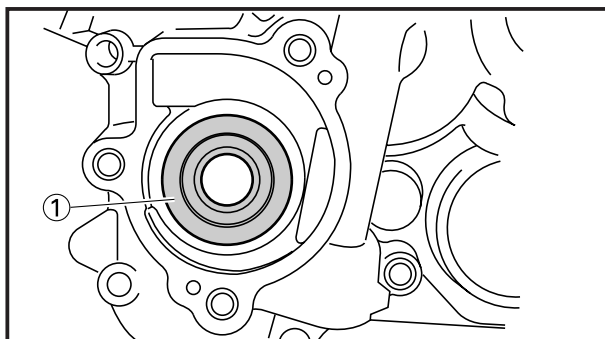

EC444400

Oil seal

1. Inspect:
 - Oil seal ①
 Wear/Damage → Replace.

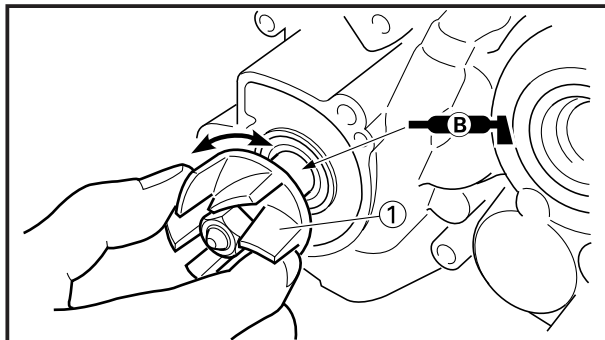
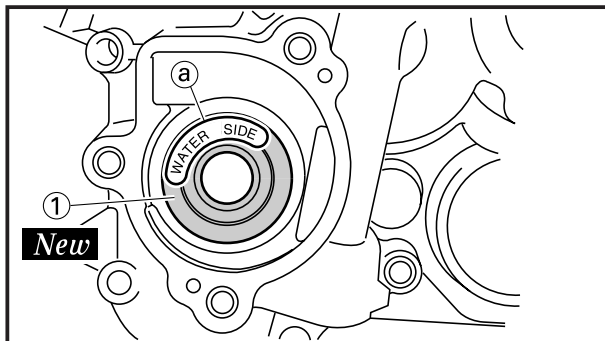

EC4Q5000

ASSEMBLY AND INSTALLATION

EC4Q5101

Oil seal (impeller shaft)

1. Install:
 - Oil seal ① **New**
To crankcase (right).

NOTE:

- Install the oil seal with the “WATER SIDE” mark Ⓐ on the outside.
- Apply the lithium soap base grease on oil seal lip.

EC4Q5201

Impeller shaft

1. Install:
 - Impeller shaft ①

NOTE:

- Take care so that the oil seal lip is not damaged or the spring does not slip off its position.
- When installing the impeller shaft, apply the lithium soap base grease on the oil seal lip and impeller shaft. And install the shaft while turning it.

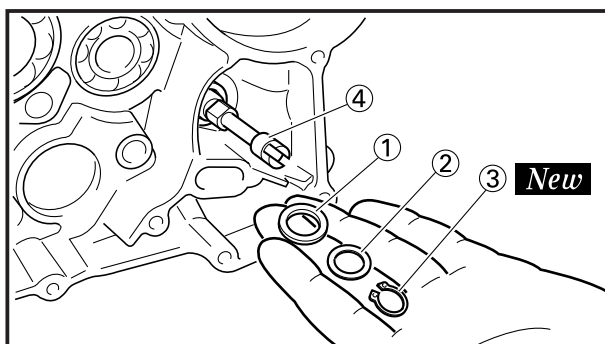

2. Install:
 - Plain washer [T=2.0 mm (0.08 in)] ①
 - Plain washer [T=1.0 mm (0.04 in)] ②
 - Circlip ③ **New**
To impeller shaft ④.

NOTE:

Install the plain washer of 2.0 mm (0.08 in) thickness first.

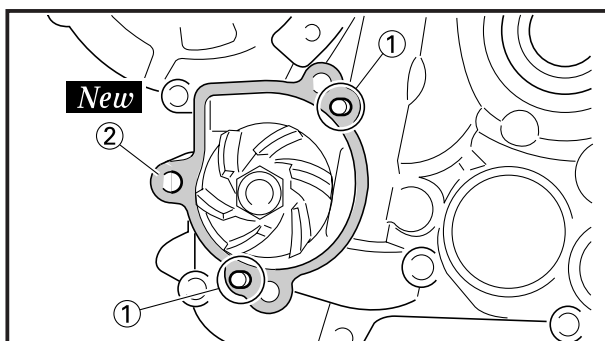

3. Install:
 - Dowel pin ①
 - Gasket (water pump housing cover) ② **New**

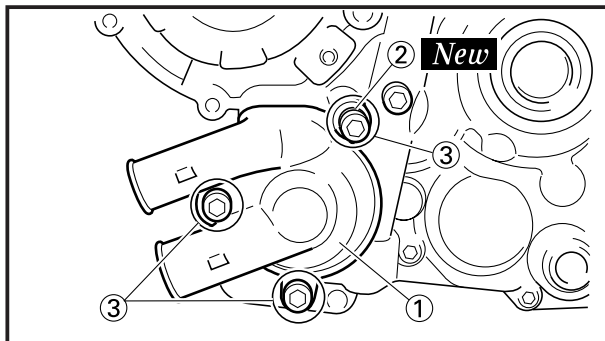

4. Install:
- Water pump housing cover ①
 - Copper washer ② **New**
 - Bolt (water pump housing cover) ③

11 Nm (1.1 m•kg, 8.0 ft•lb)

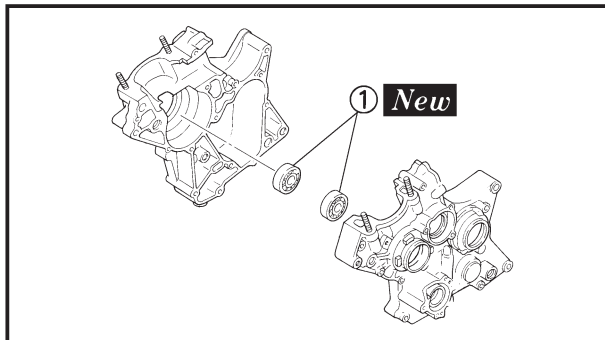

EC4N5300

Crankshaft bearing

1. Install:
- Bearing ① **New**
- To crankcase (left and right).

NOTE:

Install the bearing by pressing its outer race parallel.

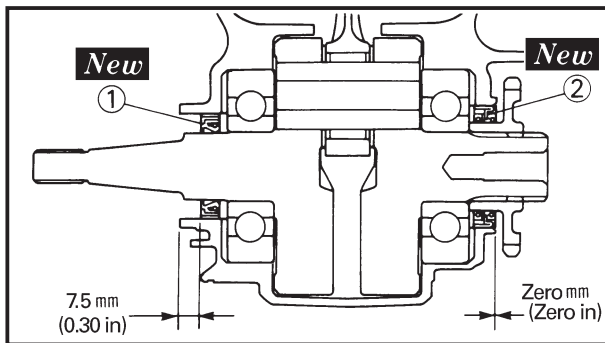

EC4Q5310

Oil seal (crankshaft)

1. Install:
- Oil seal (left) ① **New**
 - Oil seal (right) ② **New**

NOTE:

- Apply the lithium soap base grease on the oil seal lip.
- Install the oil seal with its manufacture's marks and numbers facing outward.

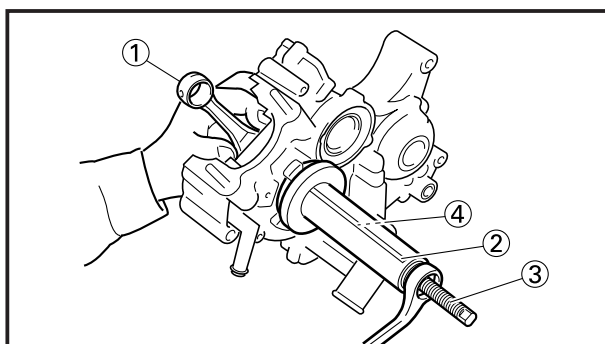

EC4Q5412

Crankshaft

1. Install:
- Crankshaft ①
- Use the crankshaft installing tool ②, ③, ④.



Crankshaft installing tool:

Pot ②: YU-90050/90890-01274

Bolt ③: YU-90050/90890-01275

Adapter ④: YU-90063/90890-01278

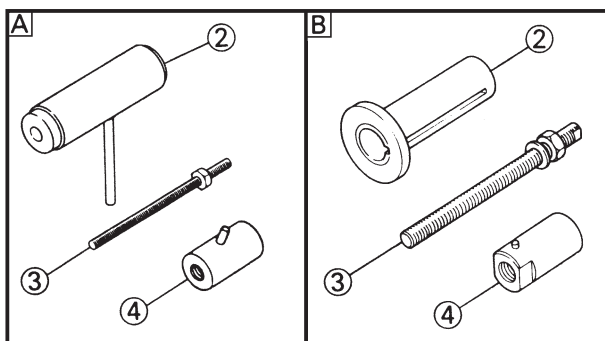

A For USA and CDN

B Except for USA and CDN



NOTE:

- Hold the connecting rod at top dead center with one hand while turning the nut of the installing tool with the other. Operate the installing tool until the crankshaft bottoms against the bearing.
- Before installing the crankshaft, clean the contacting surface of crankcase.
- Apply the lithium soap base grease on the oil seal lip.

CAUTION:

Do not use a hammer to drive in the crankshaft.

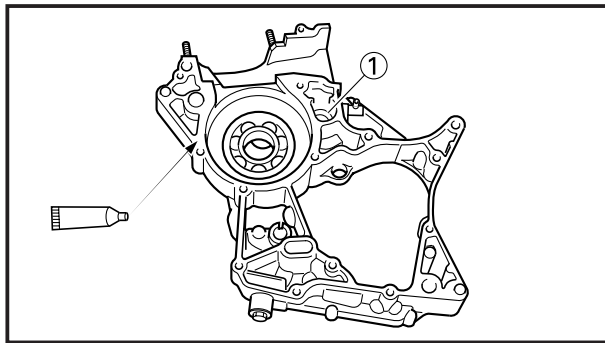

2. Apply:
 - Sealant
 On the crankcase (right) ①.



Quick gasket®:

ACC-11001-05-01
 ACC-11001-30-00
 YAMAHA Bond No.1215
 90890-85505
 YAMAHA Bond No.4
 90890-05143

NOTE:

Clean the contacting surface of crankcase (left and right) before applying the sealant.

CAUTION:

If the engine is started soon after reinstallation, use this quick drying Quick gasket® (ACC-11001-30-00) or YAMAHA Bond No.4.

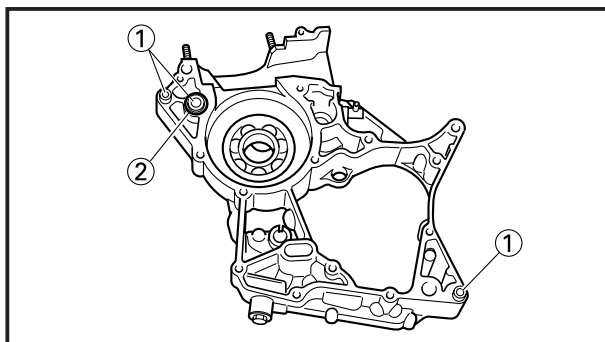

3. Install:
 - Dowel pin ①
 - O-ring ②
 To crankcase (right).

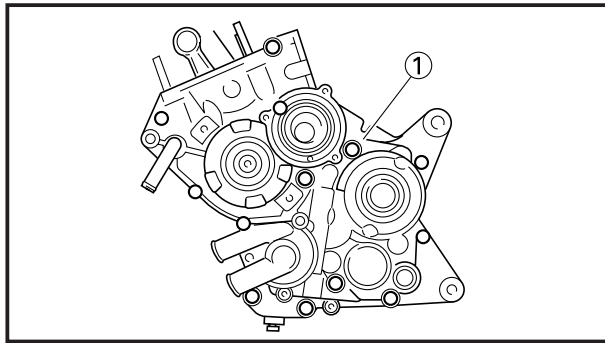

4. Install:
- Crankcase (left) ①
To crankcase (right).

NOTE:

- Fit the crankcase (left) to the crankcase (right). Tap lightly on the case with soft hammer.
- When installing the crankcase, the connecting rod should be positioned at TDC (top dead center).

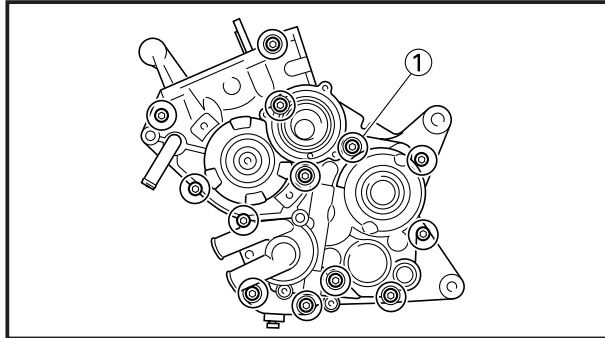

5. Tighten:
- Bolt (crankcase) ①

11 Nm (1.1 m•kg, 8.0 ft•lb)

NOTE:

Tighten the crankcase tightening bolts in stage, using a crisscross pattern.

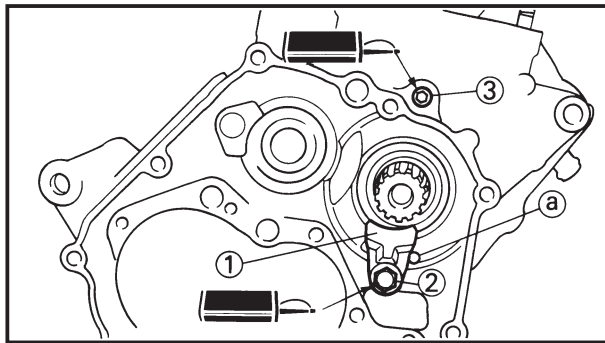

6. Install:
- Holder ①
 - Bolt (holder) ②
 - Blind plug ③

16 Nm (1.6 m•kg, 11 ft•lb)

11 Nm (1.1 m•kg, 8.0 ft•lb)

NOTE:

Install the holder so that it contacts the projection ① on the crankcase (right)

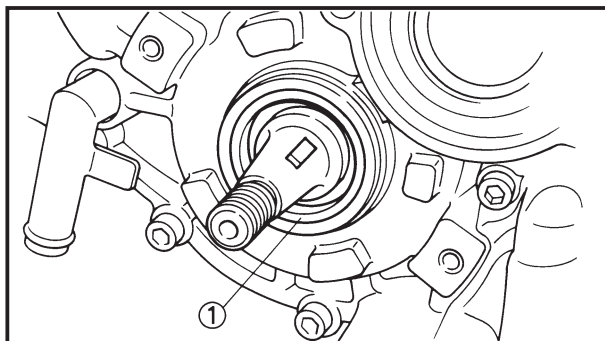

7. Install:
- Spacer ①

8. Remove:
- Sealant
Forced out on the crankcase mating surface.
9. Apply:
- Engine oil
To the crank pin, bearing, oil delivery hole and connecting rod big end washer.
10. Check:
- Crankshaft operation
Unsmooth operation → Repair.



EC500000

CHASSIS

EC590000

FRONT WHEEL AND REAR WHEEL

EC598000

FRONT WHEEL

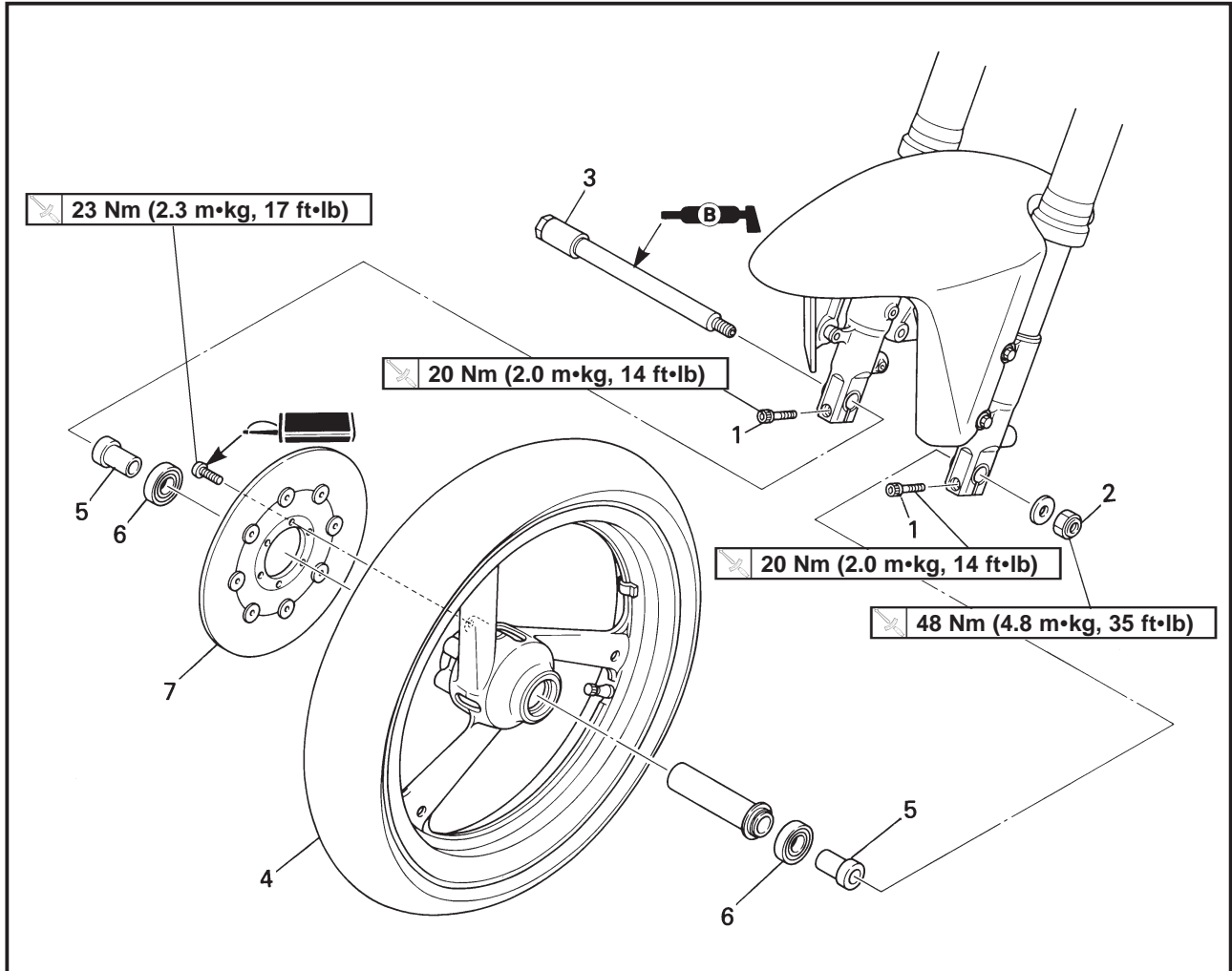

Extend of removal: ① Front wheel removal ② Wheel bearing removal
 ③ Brake disc removal

Extend of removal	Order	Part name	Q'ty	Remarks
Preparation for removal		FRONT WHEEL REMOVAL Hold the machine by placing the suitable stand.		⚠WARNING Support the machine securely so there is no danger of it falling over.
	1	Bolt (axle holder)	2	Only loosening. Refer to "REMOVAL POINTS".
	2	Nut (front wheel axle)	1	
	3	Front wheel axle	1	
	4	Front wheel	1	
	5	Collar	2	
	6	Bearing	2	
	7	Brake disk	1	

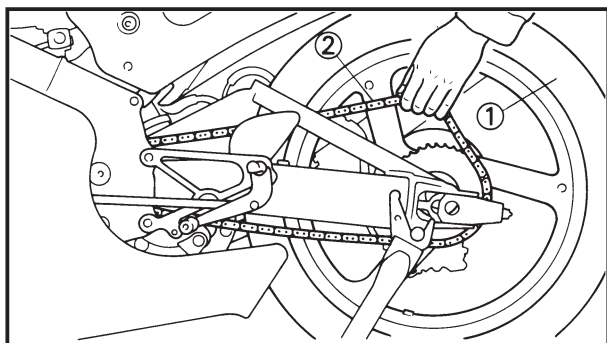

EC593000

REMOVAL POINTS

EC523101

Rear wheel

1. Remove:
 - Wheel ①

NOTE:

Push the wheel forward and remove the drive chain ②.

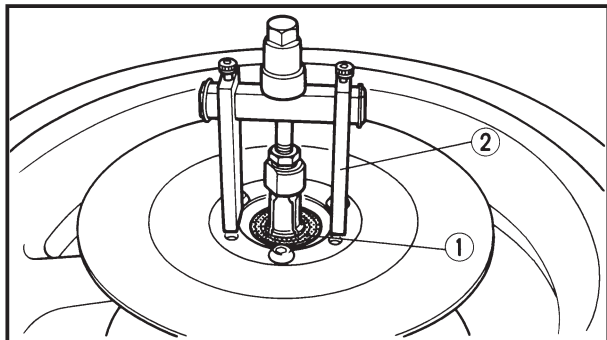

EC513201

Wheel bearing (if necessary)

1. Remove:
 - Bearing ①

NOTE:

Remove the bearing using a general bearing puller ②.

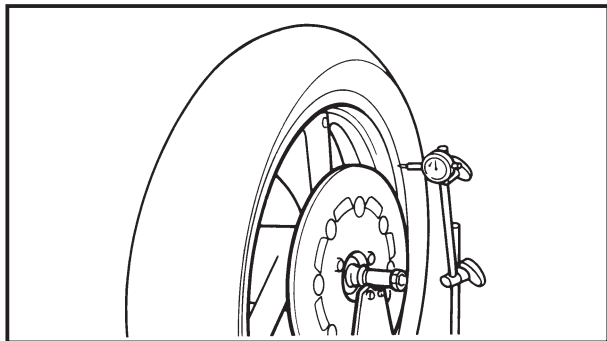

EC594000

INSPECTION

EC514110

Wheel

1. Measure:
 - Wheel runout

Out of limit → Replace.



Wheel runout limit:

Radial: 1.0 mm (0.04 in)

Lateral: 0.5 mm (0.02 in)

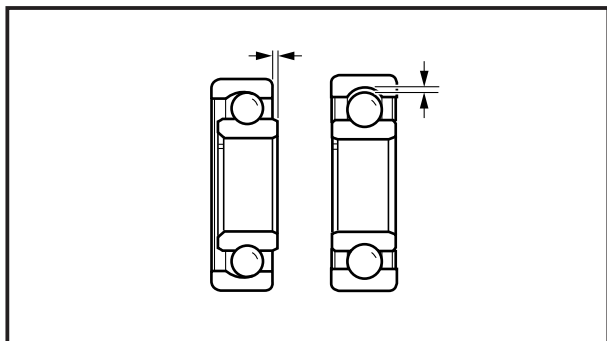

2. Inspect:

- Bearing
- Rotate inner race with a finger.
Rough spot/Seizure → Replace.

NOTE:

Replace the bearings and wheel collar as a set.

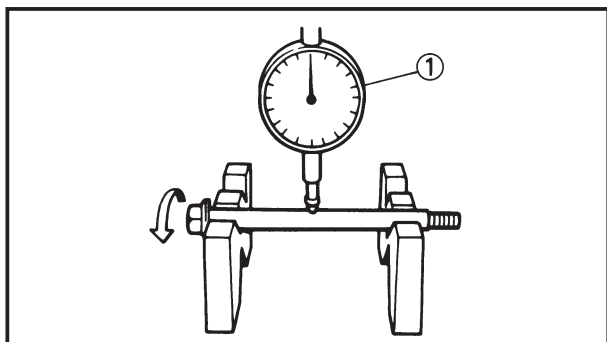

EC514200

Wheel axle

1. Measure:
 - Wheel axle bends

Out of specification → Replace.
Use the dial gauge ①.



Wheel axle bending limit:

0.25 mm (0.010 in)



NOTE:
The bending value is shown by one half of the dial gauge reading.

⚠ WARNING
Do not attempt to straighten a bent axle.

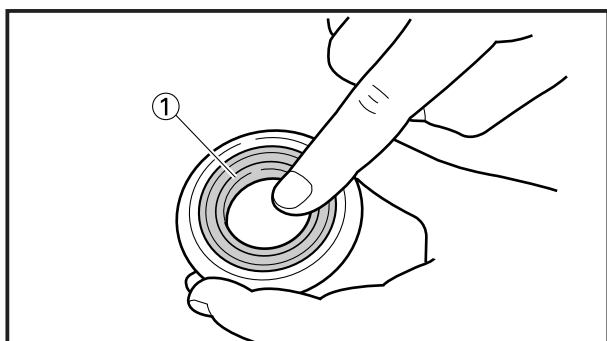
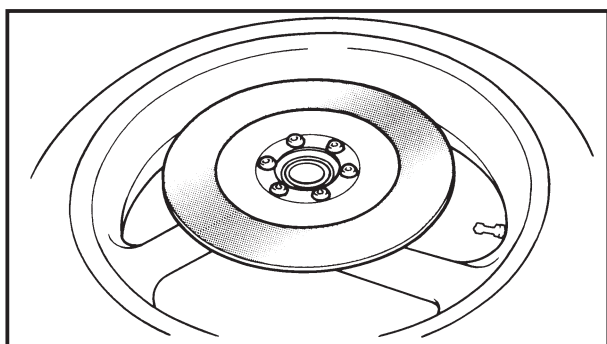
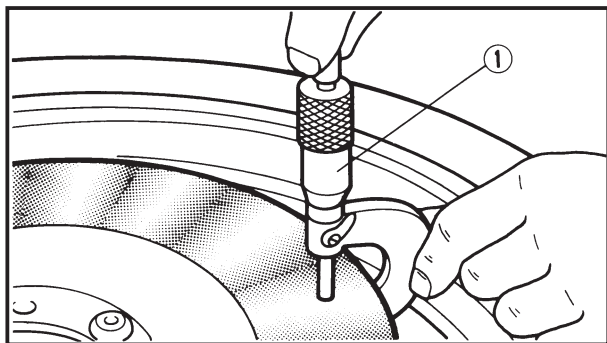
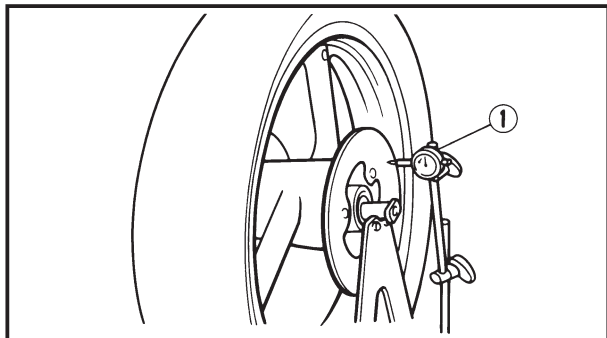

EC594100

Brake disc

- Measure:
 - Brake disc deflection (only rear brake disc)
Use the dial gauge ①.
Out of specification → Inspect wheel runout.
If wheel runout is in good condition, replace the brake disc.

Disc deflection limit:		
	Standard	<Limit>
Rear	–	0.15 mm (0.006 in)

- Measure:
 - Brake disc thickness
Use the micrometer ①.
Out of limit → Replace.

Disc wear limit:		
	Standard	<Limit>
Front	5.0 mm (0.20 in)	4.5 mm (0.18 in)
Rear	4.0 mm (0.16 in)	3.5 mm (0.14 in)

- Inspect:
 - Brake disc surface
Score marks/Damage → Replace.

EC524100

Clutch hub

- Inspect:
 - Bearing ①
Rotate inner race with a finger.
Rough spot/Seizure → Replace.

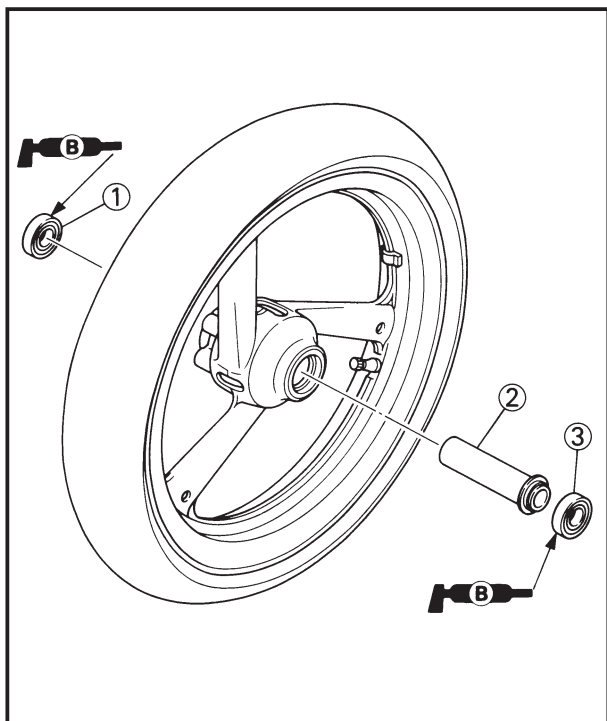

EC595000

ASSEMBLY AND INSTALLATION

EC515142

Front wheel

1. Install:
 - Bearing (right) ①
 - Spacer ②
 - Bearing (left) ③

NOTE:

- Apply the lithium soap base grease on the bearing when installing.
- Use a socket that matches the outside diameter of the race of the bearing.
- Right side of bearing shall be installed first.

CAUTION:

Do not strike the inner race of the bearing. Contact should be made only with the outer race.

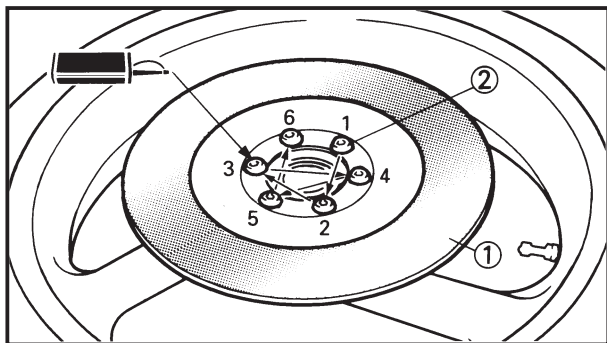

2. Install:
 - Brake disc ①
 - Bolt (brake disc) ②

23 Nm (2.3 m•kg, 17 ft•lb)

NOTE:

Tighten the bolts in stage, using a crisscross pattern.

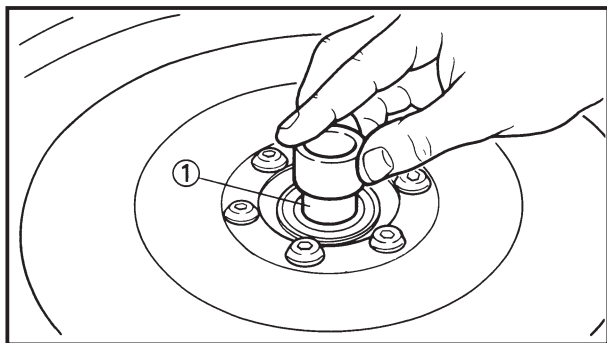

3. Install:
 - Collar ①

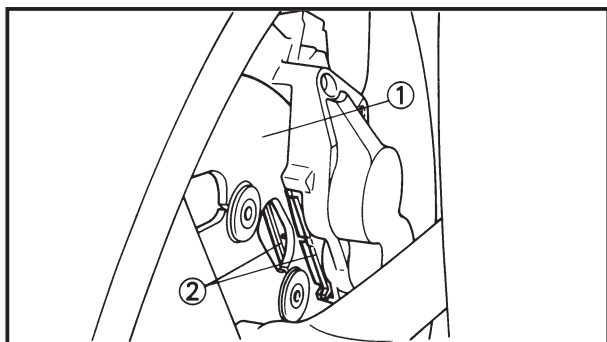

4. Install:
 - Wheel

NOTE:

Install the brake disc ① between the brake pads ② correctly.

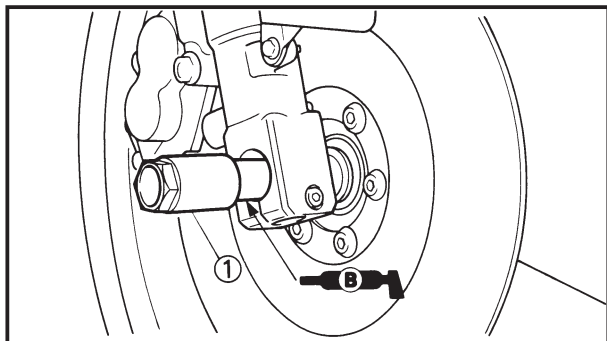

5. Install:
- Wheel axle ①

NOTE:

- Apply the lithium soap base grease on the wheel axle.
- Insert the wheel axle from right side.

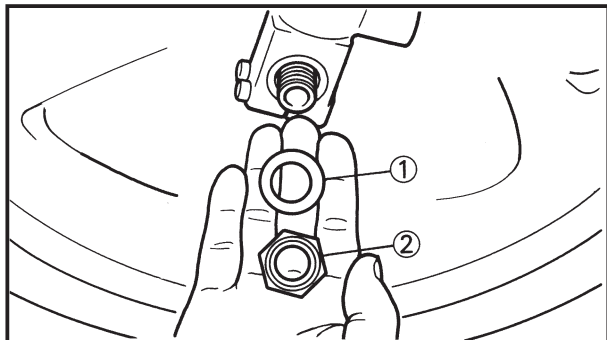

6. Install:
- Plain washer ①
 - Nut (wheel axle) ②

48 Nm (4.8 m•kg, 35 ft•lb)

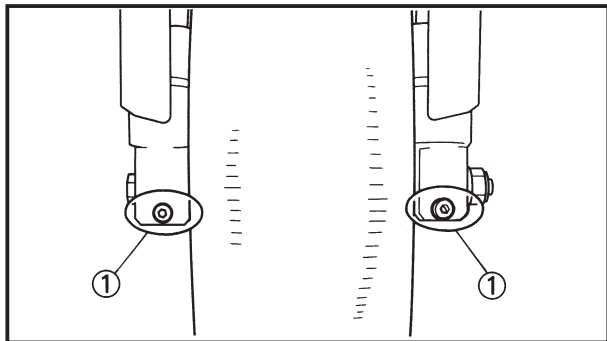

7. Tighten:
- Bolt (axle holder) ①

20 Nm (2.0 m•kg, 14 ft•lb)

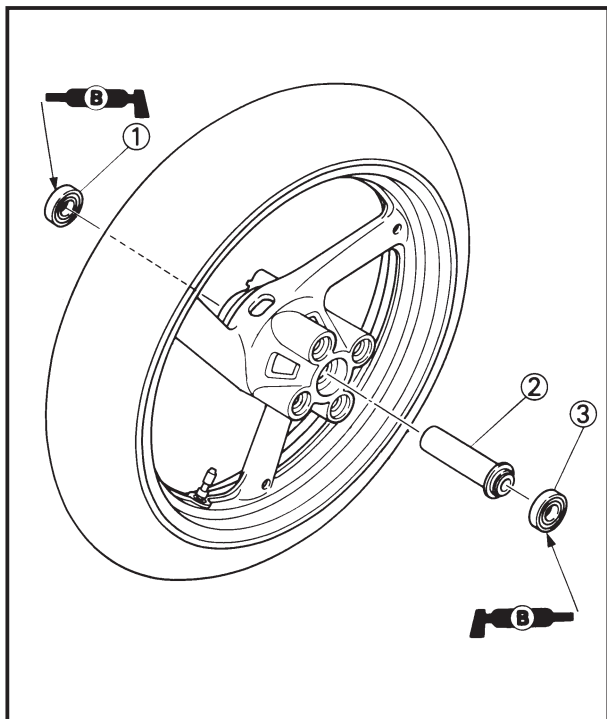

EC525191

Rear wheel

1. Install:
- Bearing (right) ①
 - Spacer ②
 - Bearing (left) ③

NOTE:

- Apply the lithium soap base grease on the bearing when installing.
- Use a socket that matches the outside diameter of the race of the bearing.
- Right side of bearing shall be installed first.

CAUTION:

Do not strike the inner race of the bearing. Contact should be made only with the outer race.

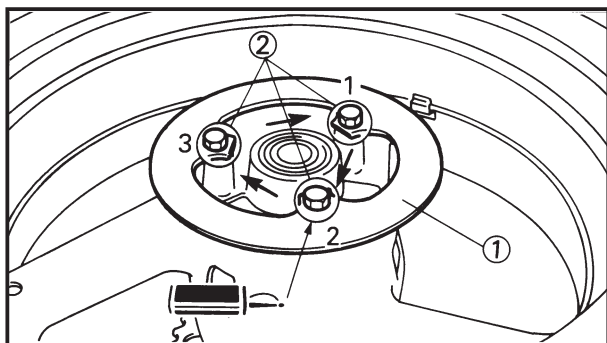

2. Install:
 - Brake disc ①
 - Bolt (brake disc) ②

23 Nm (2.3 m•kg, 17 ft•lb)

NOTE: _____

Tighten the bolts in stage, using a crisscross pattern.

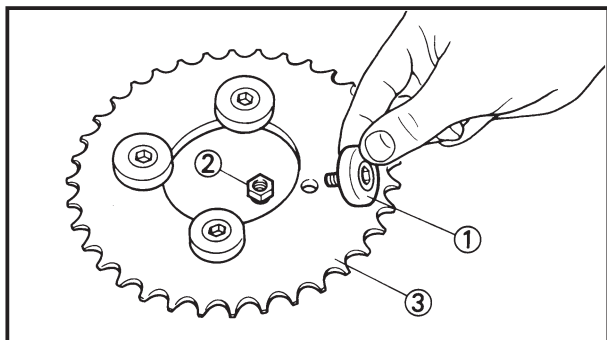

3. Install:
 - Sprocket damper ①
 - Nut (sprocket damper) ②

32 Nm (3.2 m•kg, 23 ft•lb)

To driven sprocket ③.

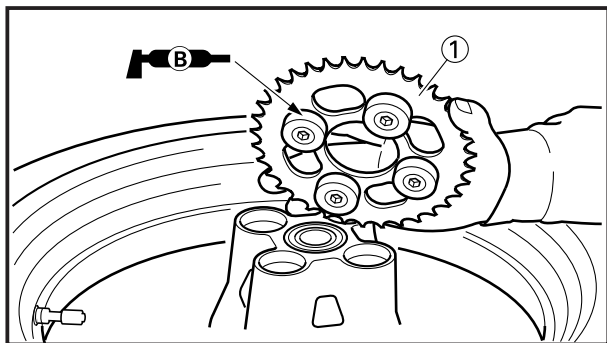

4. Install:
 - Driven sprocket ①
 To wheel.

NOTE: _____

Apply the lithium soap base grease on the sprocket damper.

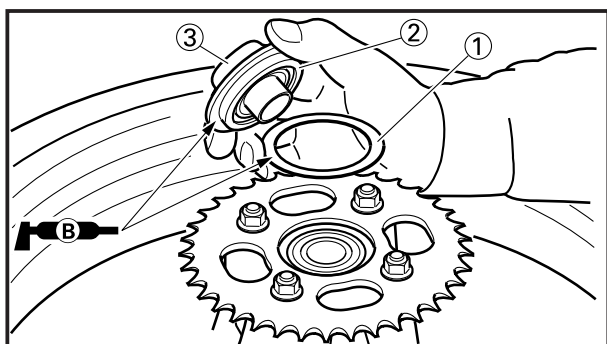

5. Install:
 - Shim ①
 - Clutch hub ②
 - Collar ③
 To wheel.

NOTE: _____

Apply the lithium soap base grease on the shim and clutch hub outer circumference.

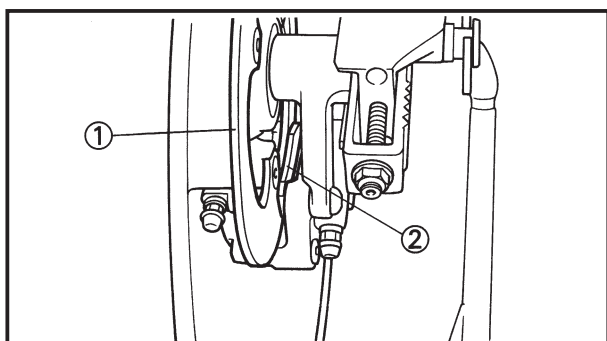

6. Install:
 - Wheel

NOTE: _____

Install the brake disc ① between the brake pads ② correctly.

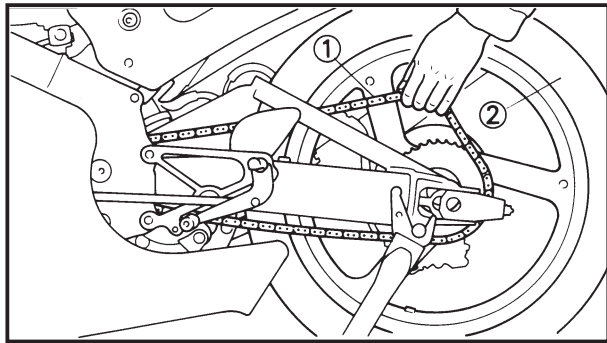

7. Install:
- Drive chain ①

NOTE: _____
 Push the wheel ② forward and install the drive chain.

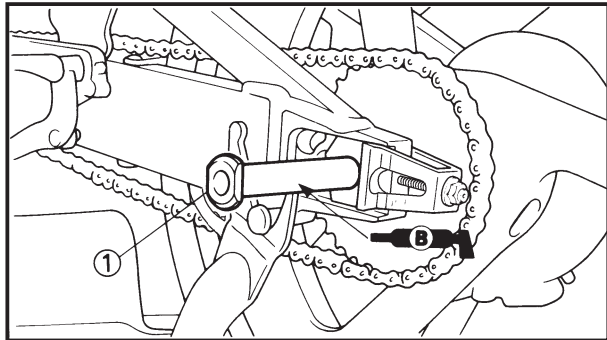

8. Install:
- Wheel axle ①

NOTE: _____
 • Apply the lithium soap base grease on the wheel axle.
 • Insert the wheel axle from left side.

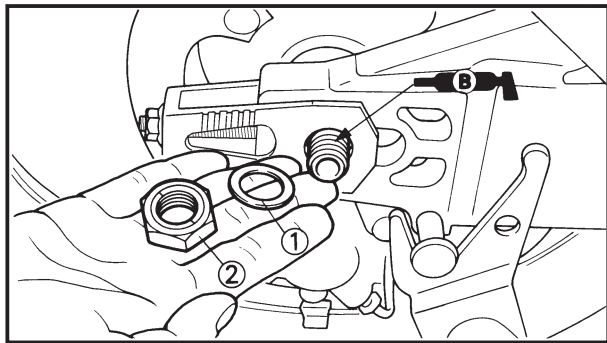

9. Install:
- Plain washer ①
 - Nut (wheel axle) ②

NOTE: _____
 • Apply the lithium soap base grease on the wheel axle thread.
 • Temporarily tighten the nut (wheel axle) at this point.

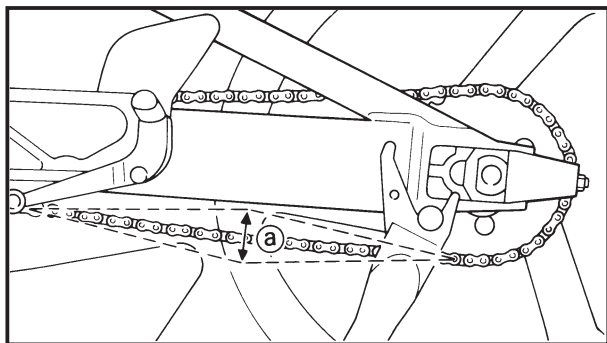

10. Adjust:
- Drive chain slack ①



Drive chain slack:
30~40 mm (1.2~1.6 in)

Refer to “DRIVE CHAIN SLACK ADJUSTMENT” section in the CHAPTER 3.

11. Tighten:
- Nut (wheel axle) ①

✖	63 Nm (6.3 m•kg, 45 ft•lb)
✖	2 Nm (0.2 m•kg, 1.4 ft•lb)
✖	16 Nm (1.6 m•kg, 11 ft•lb)

- Adjuster ②
- Locknut ③

NOTE: _____
 • Tighten the axle nut while pushing down the drive chain.
 • After tightening the axle nut, tighten the locknut with the turned out the adjuster.

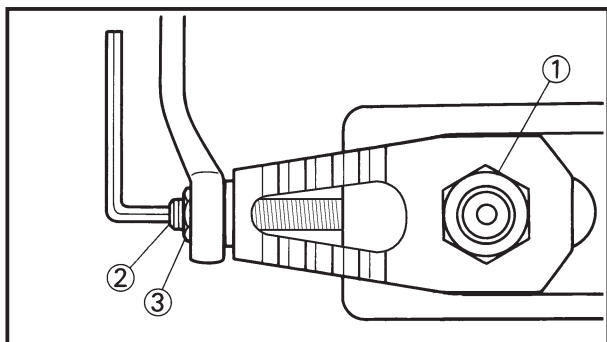

12. Adjust:
- Wheel alignment

Refer to “WHEEL ALIGNMENT ADJUSTMENT” section in the CHAPTER 3.



EC5A0000

FRONT BRAKE AND REAR BRAKE

EC5A8000

FRONT BRAKE

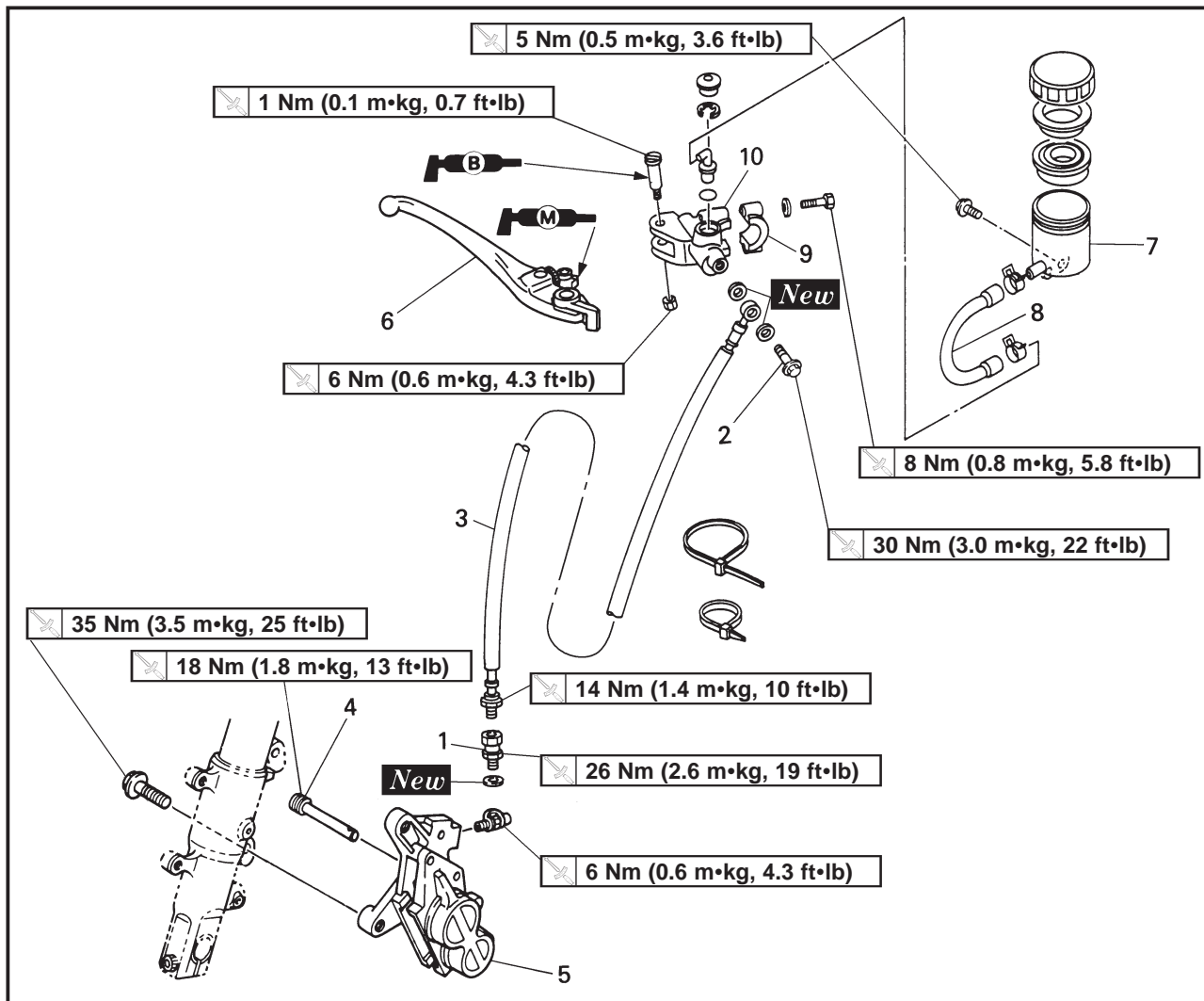

- Extend of removal:
- ① Brake hose removal
 - ② Caliper removal
 - ③ Master cylinder removal

Extend of removal	Order	Part name	Q'ty	Remarks
Preparation for removal		FRONT BRAKE REMOVAL Hold the machine by placing the suitable stand. Cowling Drain the brake fluid.		⚠WARNING Support the machine securely so there is no danger of it falling over. Refer to "COWLING, SEAT AND FUEL TANK" section in the CHAPTER 4. Refer to "REMOVAL POINTS".
	1 2 3 2 3	1 Adapter 2 Union bolt 3 Brake hose 4 Pad pin 5 Caliper 6 Brake lever 7 Reservoir tank 8 Reservoir hose 9 Master cylinder bracket 10 Master cylinder	1 1 1 1 1 1 1 1 1 1	Loosen when disassembling the caliper.

EC5A8200

CALIPER DISASSEMBLY

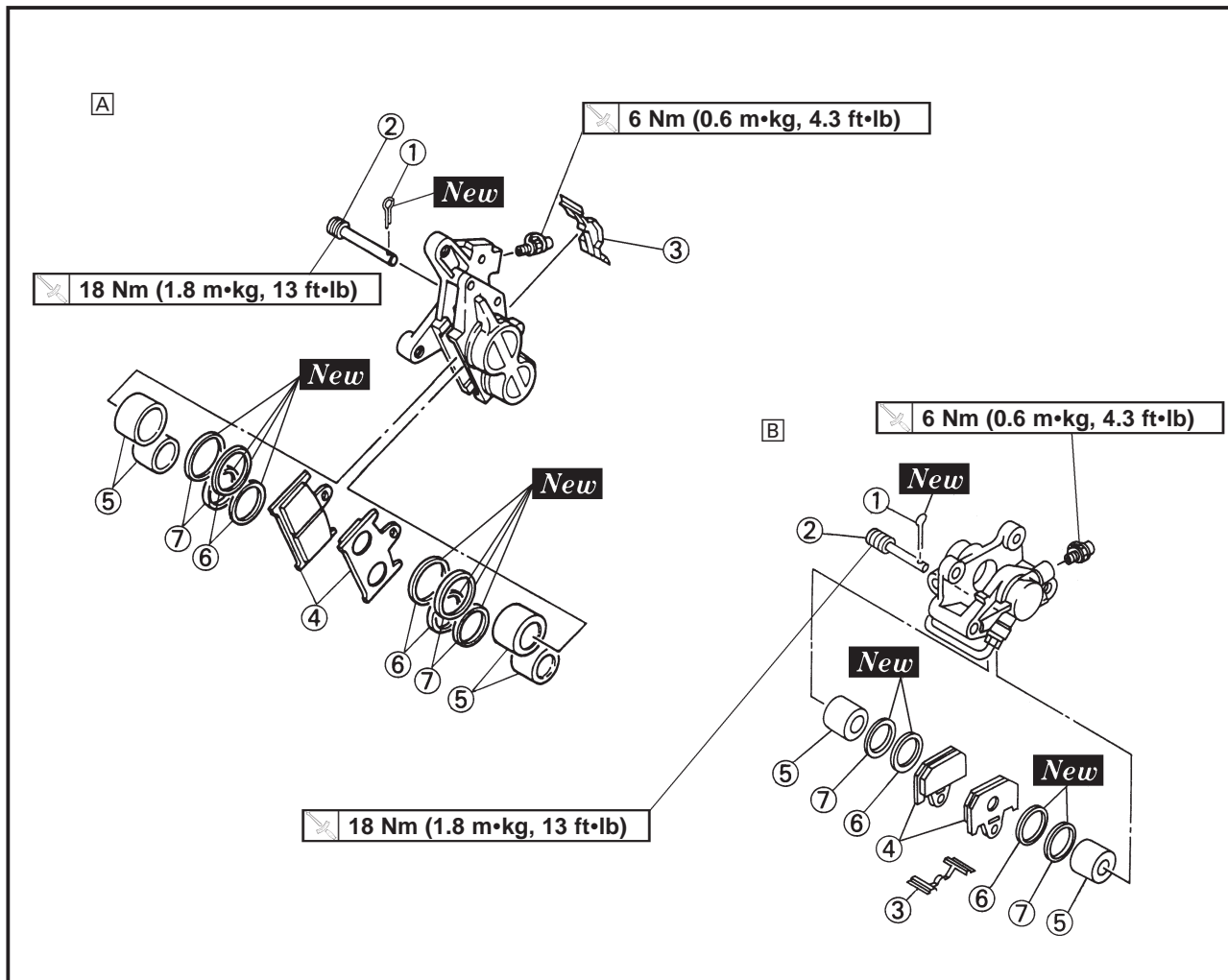

A Front

B Rear

Extend of removal: ① Front caliper disassembly

② Rear caliper disassembly

Extend of removal	Order	Part name	Q'ty		Remarks	
			A	B		
<div style="display: flex; justify-content: space-around;"> <div style="text-align: center;">↑ ① ↓</div> <div style="text-align: center;">↑ ② ↓</div> </div>	CALIPER DISASSEMBLY			A	B	Refer to "REMOVAL POINTS".
	①	Cotter pin	1	1		
	②	Pad pin	1	1		
	③	Pad support	1	1		
	④	Brake pad	2	2		
	⑤	Caliper piston	4	2		
	⑥	Dust seal	4	2		
	⑦	Piston seal	4	2		



EC5A8300

MASTER CYLINDER DISASSEMBLY

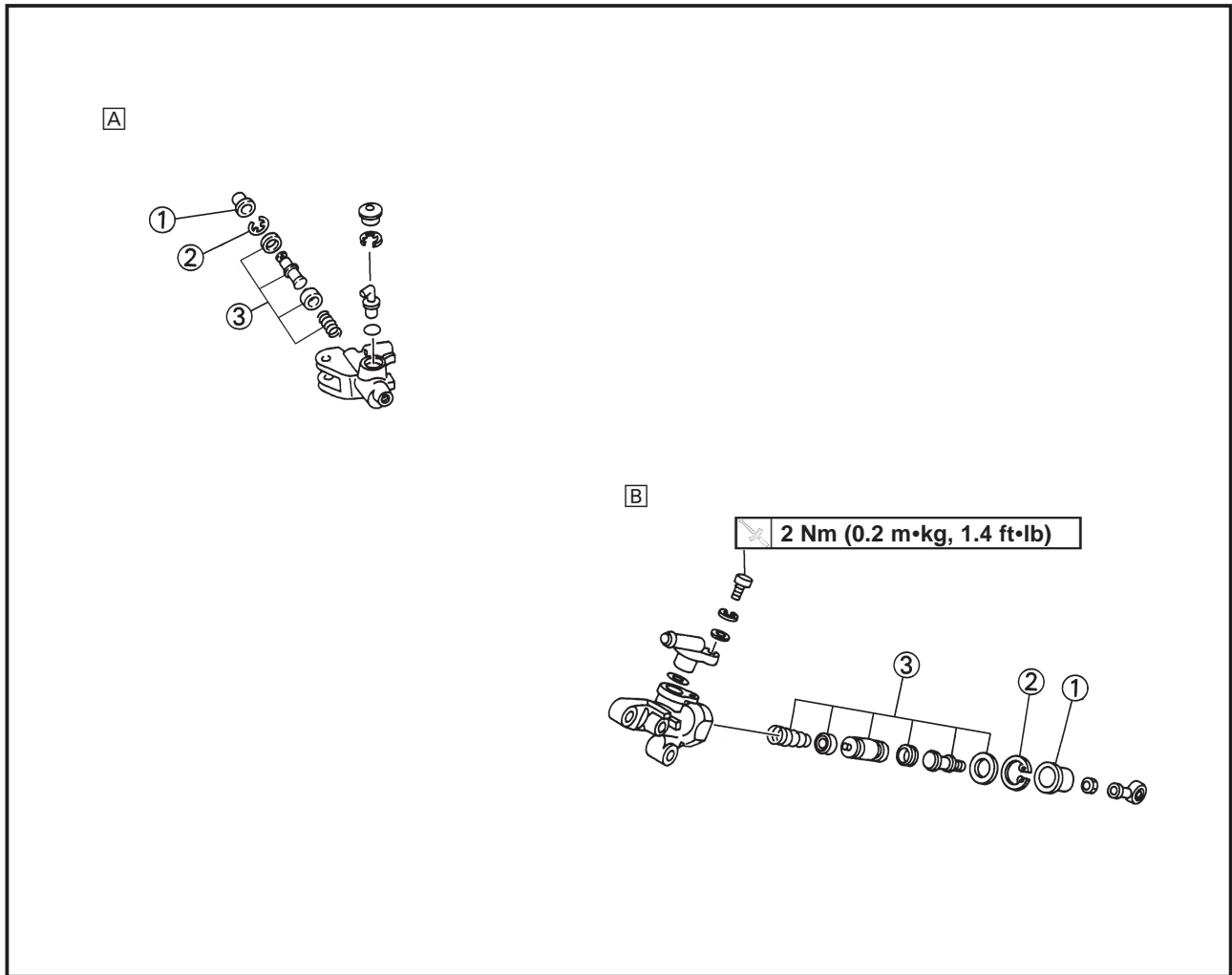

A Front

B Rear

Extend of removal: ① Front master cylinder disassembly

② Rear master cylinder disassembly

Extend of removal	Order	Part name	Q'ty	Remarks
		MASTER CYLINDER DISASSEMBLY		
↑ ① ↓	①	Master cylinder boot	1	
↑ ② ↓	②	Circlip	1	
	③	Master cylinder kit	1	



EC536000

HANDLING NOTE

⚠WARNING

The brake components of this machine are suit for closed circuit use only. Never use on any public road.

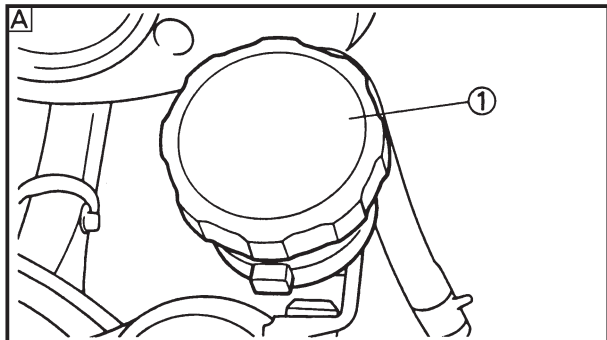

EC5A3000

REMOVAL POINTS

EC5A3200

Brake fluid

1. Remove:
 - Reservoir tank cap ①

NOTE:

Do not remove the diaphragm.

A Front

B Rear

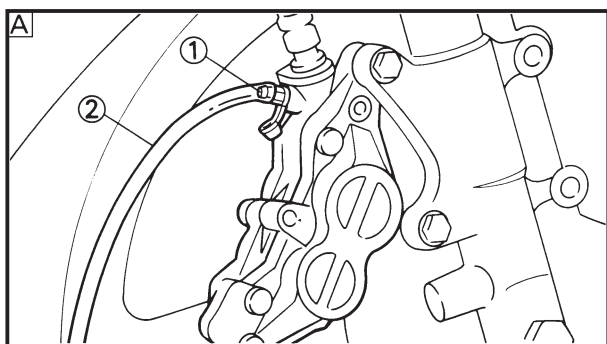
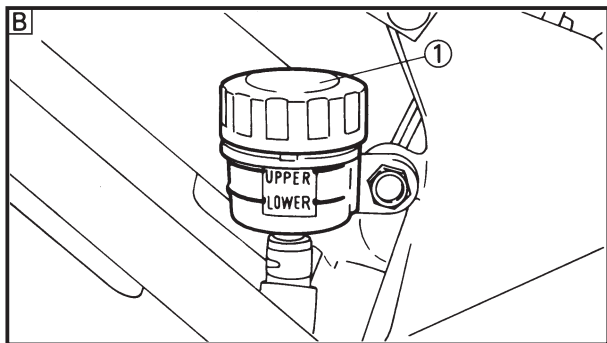

2. Connect the transparent hose ② to the bleed screw ① and place a suitable container under its end.

A Front

B Rear

3. Loosen the bleed screw and drain the brake fluid while pulling the lever in or pushing down on the pedal.

CAUTION:

- Do not reuse the drained brake fluid.
- Brake fluid may erode painted surfaces or plastic parts. Always clean up spilled fluid immediately.

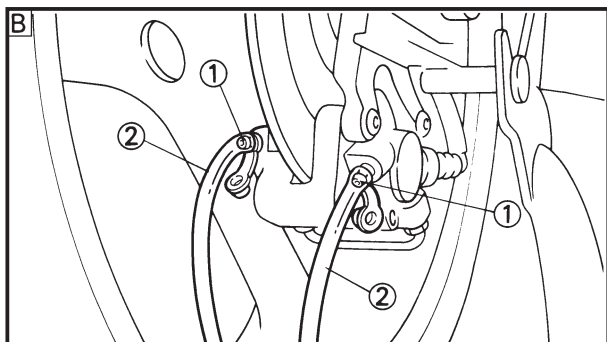

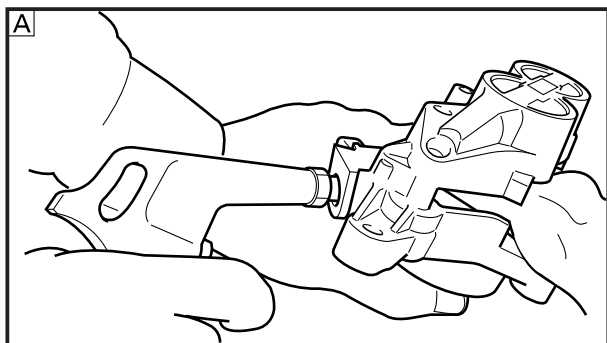

EC533301

Caliper piston

- Remove:
 - Caliper piston
 Use compressed air and proceed carefully.

⚠WARNING

- Cover piston with rag and use extreme caution when expelling piston from cylinder.
- Never attempt to pry out piston.

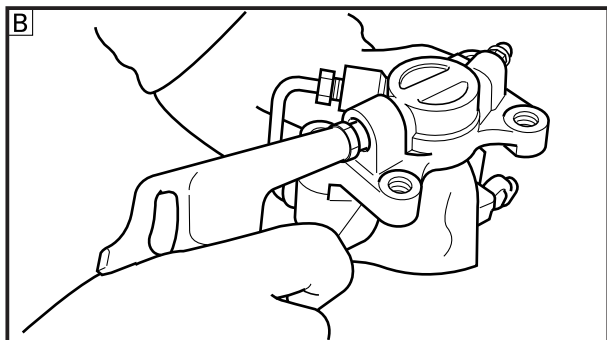

Caliper piston removal steps:

- Insert a piece of rag into the caliper to lock one caliper.
- Carefully force the piston out of the caliper cylinder with compressed air.

A Front

B Rear

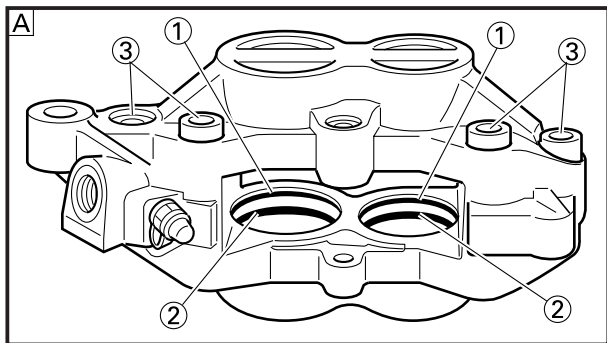

EC543411

Piston seal kit

- Remove:
 - Dust seal ①
 - Piston seal ②

NOTE:

Remove the piston seals and dust seals by pushing them with a finger.

CAUTION:

- Never attempt to pry out piston seals and dust seals.
- Do not loosen the bolts ③ and nuts ④.

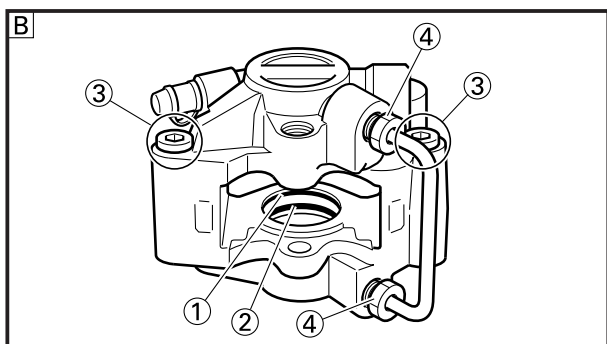

⚠WARNING

Replace the piston seals and dust seals whenever a caliper is disassembled.

A Front

B Rear

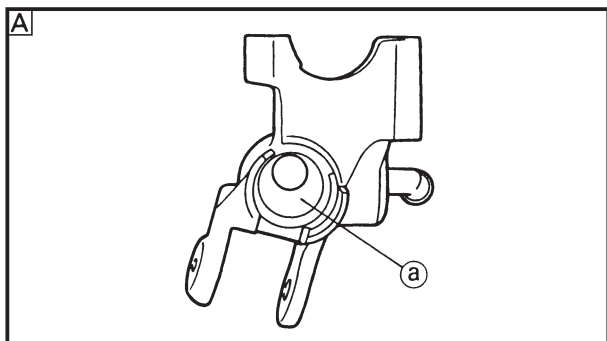

EC5A4000

INSPECTION

EC534112

Master cylinder

1. Inspect:

- Master cylinder inner surface (a)
Wear/Scratches → Replace master cylinder assembly.
Stains → Clean.

⚠ WARNING

Use only new brake fluid.

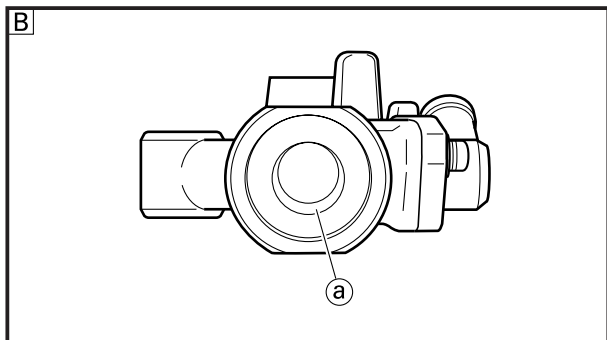

A Front

B Rear

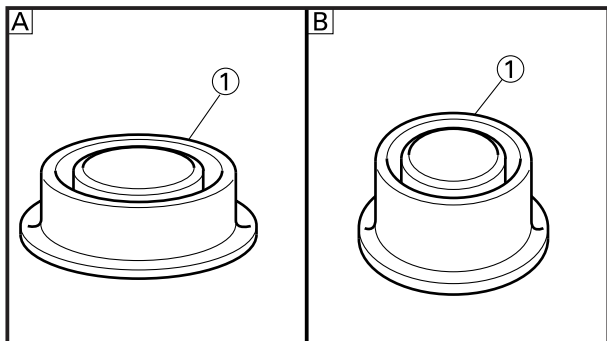

2. Inspect:

- Diaphragm (1)
Crack/Damage → Replace.

A Front

B Rear

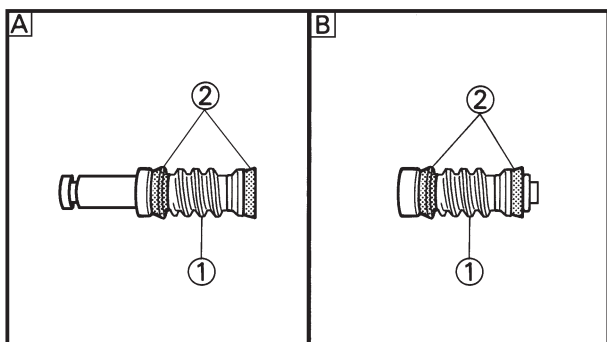

3. Inspect:

- Master cylinder piston (1)
- Master cylinder cup (2)
Wear/Damage/Score marks → Replace master cylinder kit.

A Front

B Rear

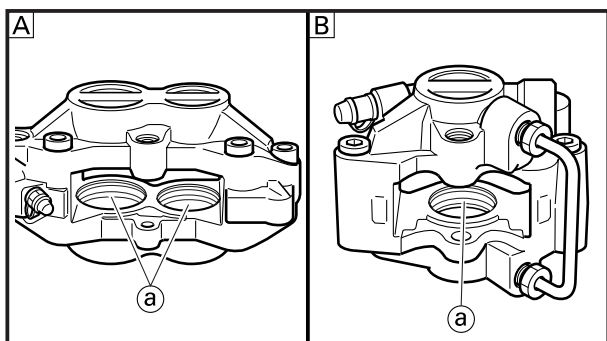

EC534214

Caliper

1. Inspect:

- Caliper cylinder inner surface (a)
Wear/Score marks → Replace caliper assembly.

A Front

B Rear

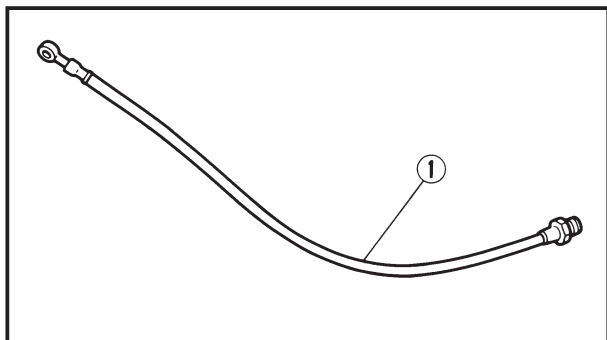
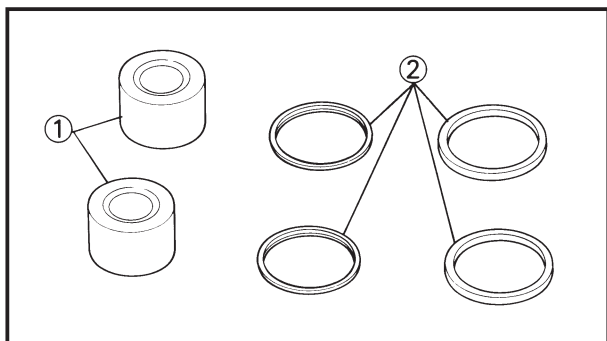

2. Inspect:
 - Caliper piston ①
 - Wear/Score marks → Replace caliper piston assembly.

⚠WARNING

Replace the piston seals and dust seals ② whenever a caliper is disassembled.

EC534301

Brake hose

1. Inspect:
 - Brake hose ①
 - Crack/Damage → Replace.

EC5A5000

ASSEMBLY AND INSTALLATION

⚠WARNING

- All internal parts should be cleaned in new brake fluid only.
- Internal parts should be lubricated with brake fluid when installed.
- Replace the piston seals and dust seals whenever a caliper is disassembled.

EC535113

Caliper piston

1. Clean:
 - Caliper
 - Piston seal
 - Dust seal
 - Caliper piston
 - Clean them with brake fluid.
2. Install:
 - Piston seal ① **New**
 - Dust seal ② **New**

⚠WARNING

Always use new piston seals and dust seals.

NOTE:

Fit the piston seals and dust seals onto the slot on caliper correctly.

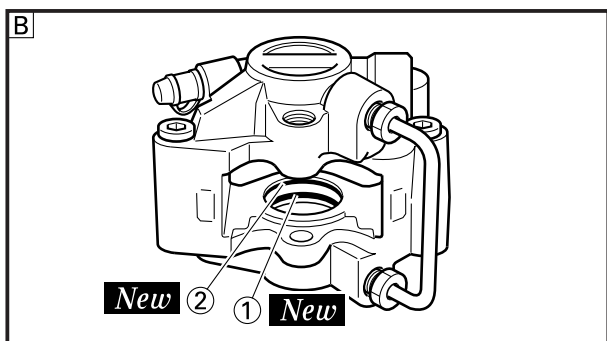
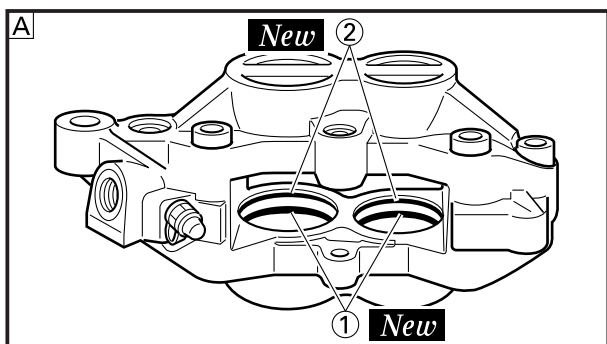

Ⓐ Front

Ⓑ Rear

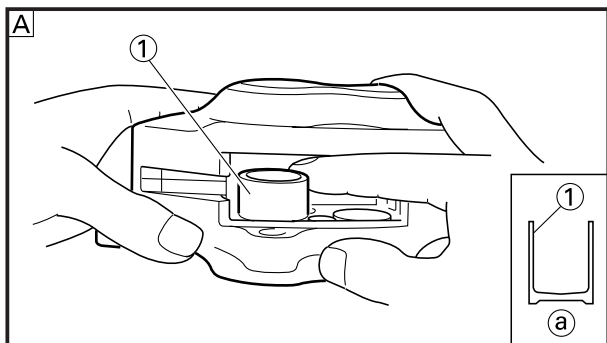

3. Install:
- Caliper piston ①

NOTE:

Apply the brake fluid on the piston wall.

CAUTION:

- Install the piston with its shallow depressed side (a) facing the caliper.
- Never force to insert.

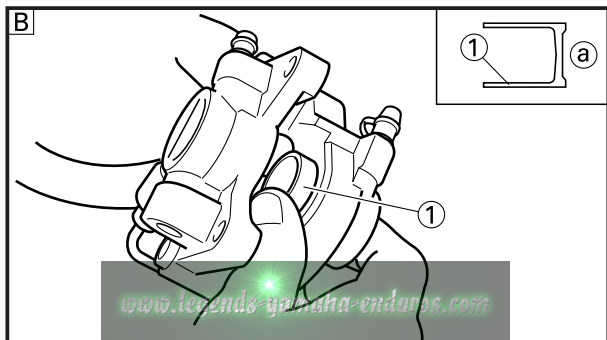

A Front

B Rear

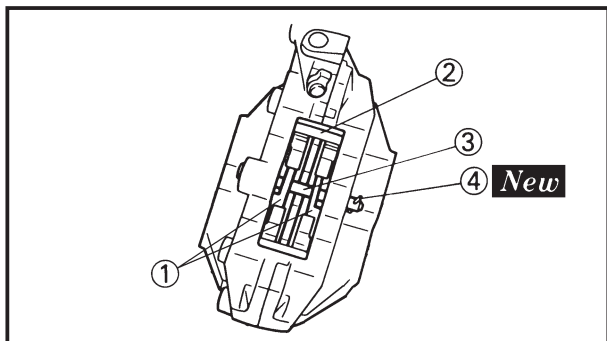

EC535241

Front caliper

1. Install:
- Brake pad ①
 - Pad support ②
 - Pad pin ③
 - Cotter pin ④ **New**

NOTE:

Temporarily tighten the pad pin at this point.

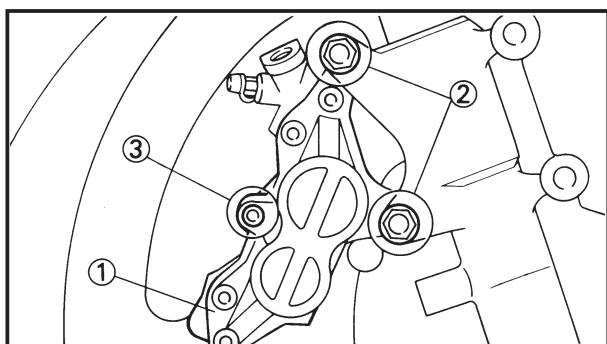

2. Install:

- Caliper ①
- Bolt (caliper) ②

35 Nm (3.5 m•kg, 25 ft•lb)

3. Tighten:

- Pad pin ③

18 Nm (1.8 m•kg, 13 ft•lb)

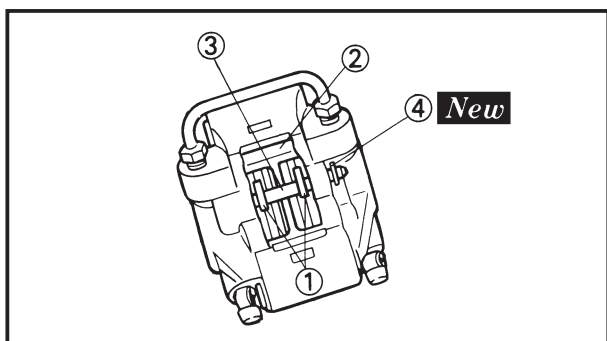

EC545141

Rear caliper

1. Install:
- Brake pad ①
 - Pad support ②
 - Pad pin ③
 - Cotter pin ④ **New**

NOTE:

Temporarily tighten the pad pin at this point.

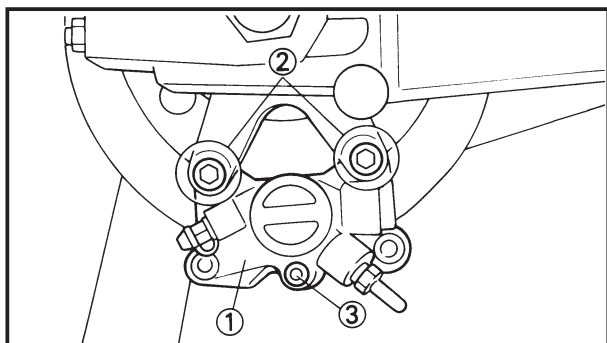

2. Install:
 - Caliper ①
 - Bolt (caliper) ②

23 Nm (2.3 m•kg, 17 ft•lb)

3. Tighten:
 - Pad pin ③

18 Nm (1.8 m•kg, 13 ft•lb)

EC5A5210

Master cylinder kit

1. Clean:
 - Master cylinder
 - Master cylinder kit

Clean them with brake fluid.

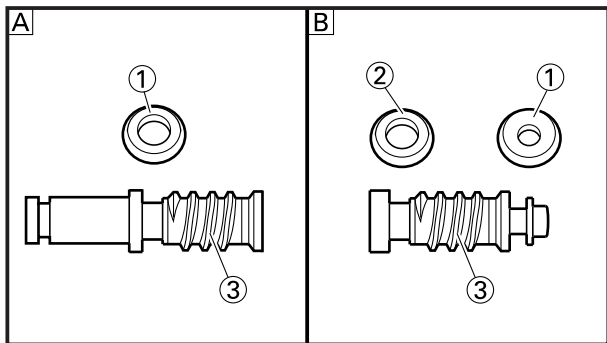

2. Install:
 - Master cylinder cup (primary) ①
 - Master cylinder cup (secondary) ②

To master cylinder piston ③.

NOTE: _____
Apply the brake fluid on the master cylinder cup.

⚠ WARNING _____
After installing, cylinder cup should be installed as shown direction. Wrong installation cause improper brake performance.

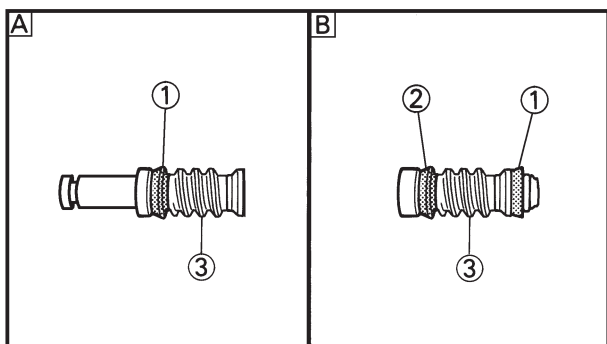

- A Front
- B Rear

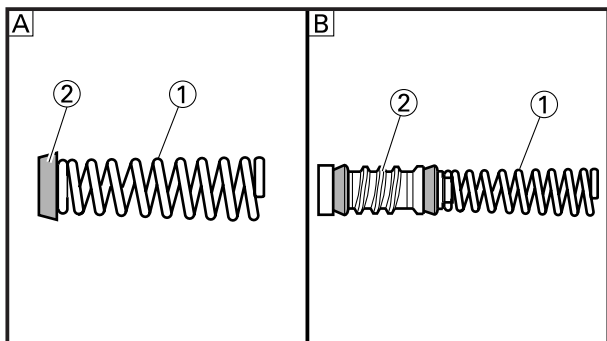

3. Install:
- [Front]
 - Spring ①
 - To master cylinder cup (secondary) ②.
 - [Rear]
 - Spring ①
 - To master cylinder piston ②.

NOTE: _____
Install the spring at the smaller dia. side.

⚠ WARNING _____

After installing, cylinder cup should be installed as shown direction. Wrong installation cause improper brake performance.

- Ⓐ Front
- Ⓑ Rear

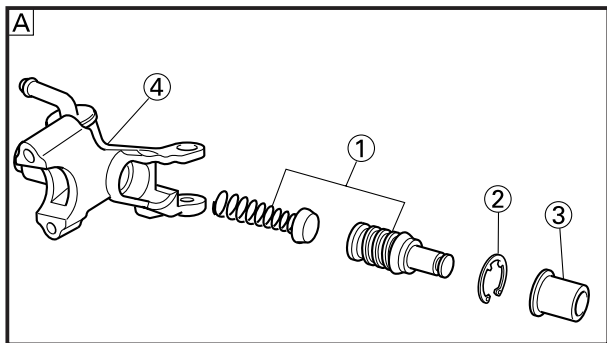

4. Install:
- Master cylinder kit ①
 - Circlip ②
 - Master cylinder boot ③
 - To master cylinder ④.

NOTE: _____
• Apply the brake fluid on the master cylinder kit.
• When installing the circlip, use a long nose circlip pliers.

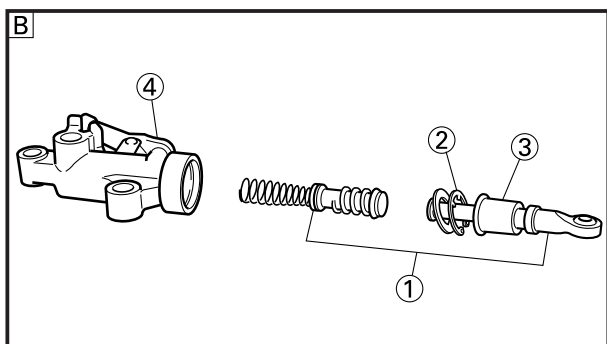

- Ⓐ Front
- Ⓑ Rear

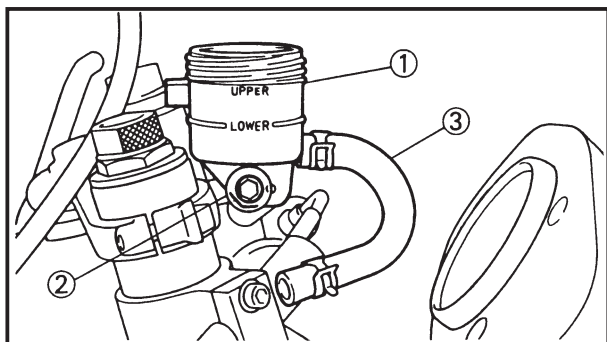

EC535421

Front master cylinder

1. Install:
- Reservoir tank ①
 - Bolt (reservoir tank) ②
 - Reservoir hose ③

5 Nm (0.5 m•kg, 3.6 ft•lb)

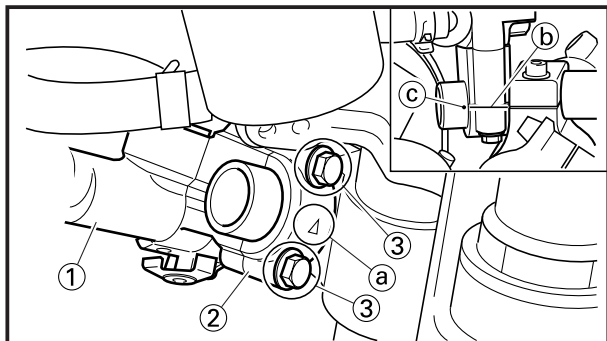

2. Install:
- Master cylinder ①
 - Master cylinder bracket ②
 - Bolt (master cylinder bracket) ③

8 Nm (0.8 m•kg, 5.8 ft•lb)

NOTE:

- Install the bracket so that the arrow mark ① face upward.
- When installing master cylinder, align the contacting surface ② of the master cylinder bracket with the punch mark ③ on the handlebar.

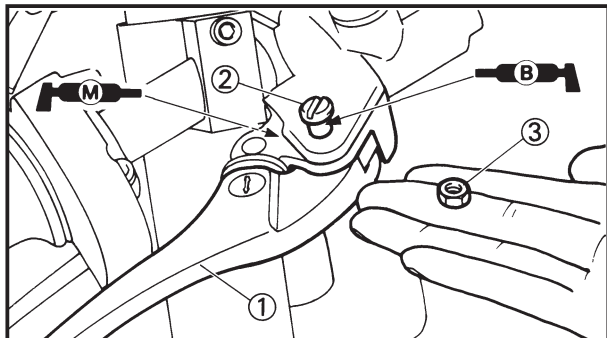

3. Install:
- Brake lever ①
 - Bolt (brake lever) ②

1 Nm (0.1 m•kg, 0.7 ft•lb)

- Nut (brake lever) ③

6 Nm (0.6 m•kg, 4.3 ft•lb)

NOTE:

- Apply the lithium soap base grease on the bolt.
- When installing the brake lever, apply the molybdenum disulfide grease on the contacting surface of the master cylinder piston.

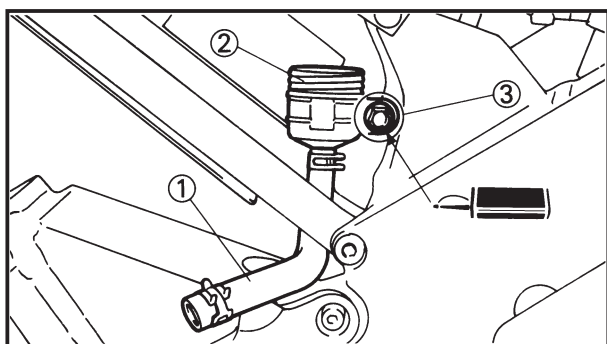

EC545232

Rear master cylinder

1. Install:
- Reservoir hose ①
 - Reservoir tank ②
 - Bolt (reservoir tank) ③

3 Nm (0.3 m•kg, 4.3 ft•lb)

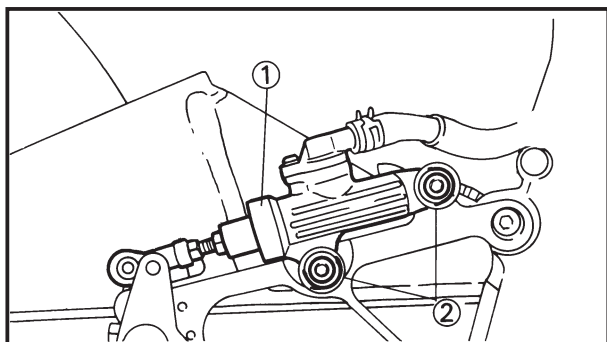

2. Install:
- Master cylinder ①
 - Bolt (master cylinder) ②

20 Nm (2.0 m•kg, 14 ft•lb)

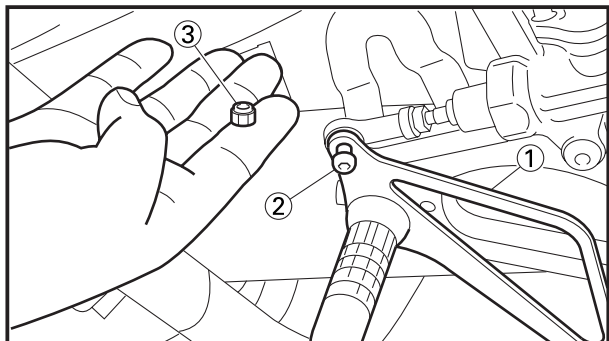

3. Install:
- Brake pedal ①
 - Brake pedal connecting bolt ②
 - Nut (brake pedal connecting bolt) ③

12 Nm (1.2 m•kg, 8.7 ft•lb)

NOTE:

After installing, check the brake pedal height. Refer to “REAR BRAKE ADJUSTMENT” section in the CHAPTER 3.

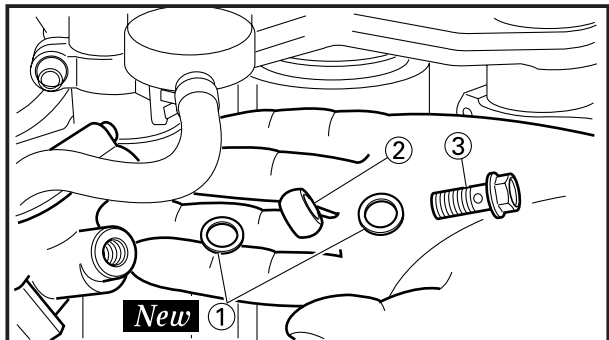

EC535561

Front brake hose

1. Install:

- Copper washer ① **New**
- Brake hose ②
- Union bolt ③

30 Nm (3.0 m•kg, 22 ft•lb)

⚠WARNING

Always use new copper washers.

CAUTION:

Install the brake hose so that it forms an angle $\text{\textcircled{a}}$ of 105° to the brake lever ④.

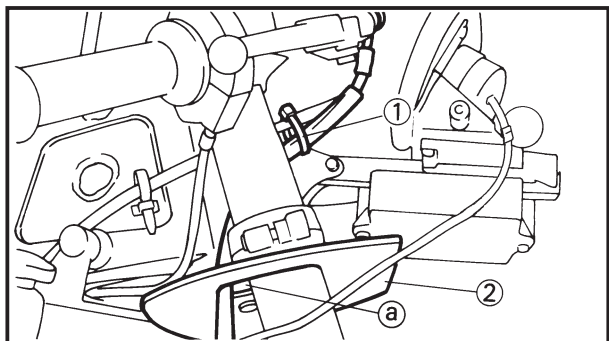
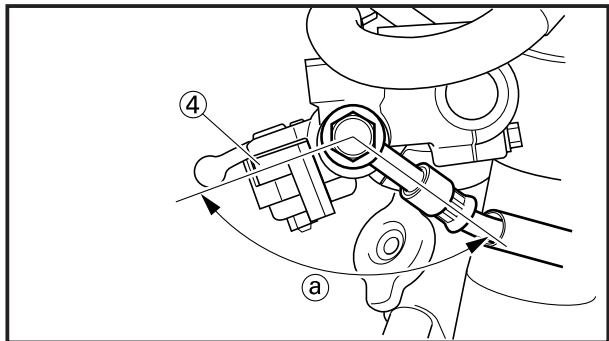

2. Pass the brake hose through the clamp ① and hole $\text{\textcircled{a}}$ of the inner fender ②.

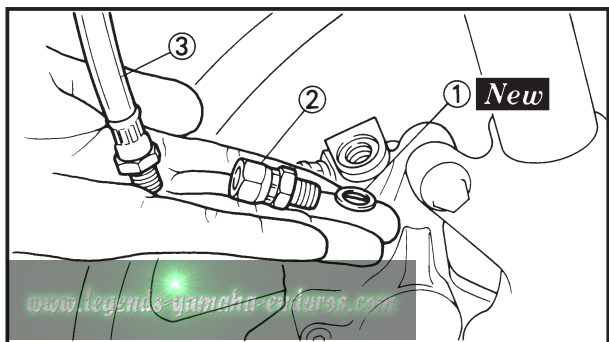

3. Install:

- Copper washer ① **New**
- Adapter ②
- Brake hose ③

26 Nm (2.6 m•kg, 19 ft•lb)

14 Nm (1.4 m•kg, 10 ft•lb)

⚠WARNING

Always use a new copper washer.

NOTE:

When turning the adapter over the brake hose, hold the brake hose so that it may not be twisted.

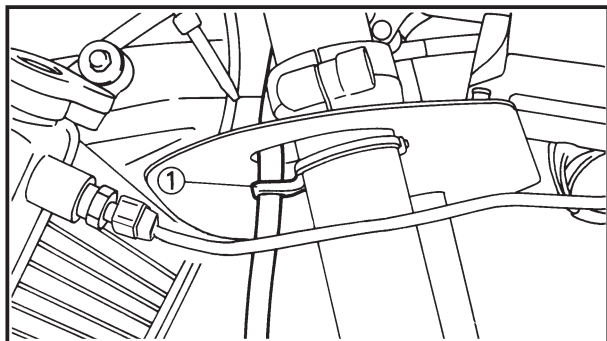

4. Install:
- Clamp ①
- Refer to “CABLE ROUTING DIAGRAM” section in the CHAPTER 2.

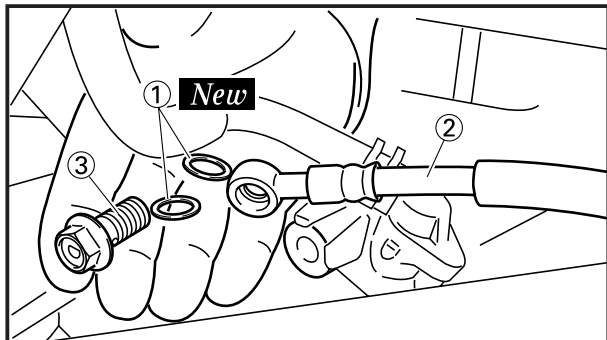

EC545442
Rear brake hose

1. Install:
- Copper washer ① **New**
 - Brake hose ②
 - Union bolt ③

30 Nm (3.0 m•kg, 22 ft•lb)

⚠ WARNING

Always use new copper washers.

CAUTION:

When installing the brake hose to the master cylinder, lightly touch the brake pipe ① with the projection ② on the master cylinder.

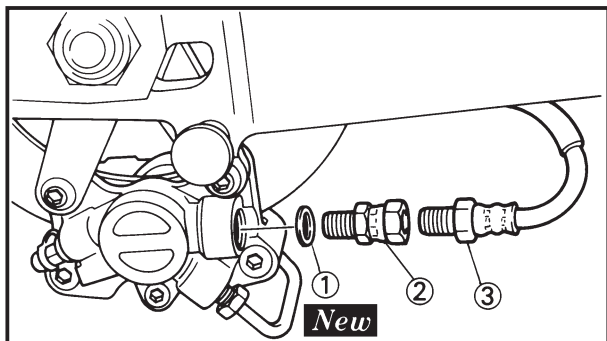
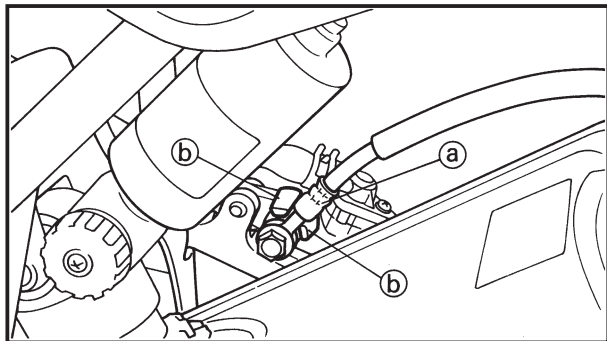

2. Install:
- Copper washer ① **New**
 - Adapter ② 26 Nm (2.6 m•kg, 19 ft•lb)
 - Brake hose ③ 14 Nm (1.4 m•kg, 10 ft•lb)

⚠ WARNING

Always use a new copper washer.

NOTE:

When turning the adapter over the brake hose, hold the brake hose so that it may not be twisted.

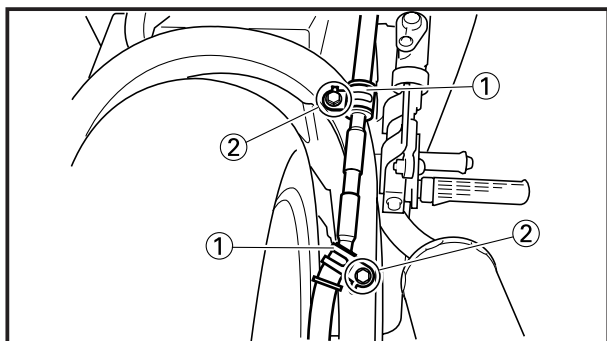

3. Install:
 - Brake hose holder ①
 - Bolt (brake hose holder) ②

8Nm (0.8 m•kg, 5.8 ft•lb)

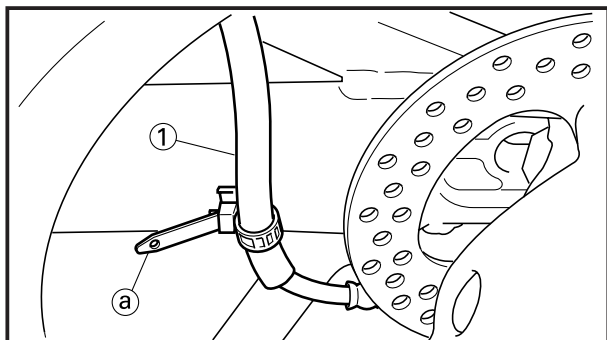

4. Install:
 - Brake hose ①

NOTE: _____
 Clamp the brake hose with the end of the clamp **a** forward. Refer to “CABLE ROUTING DIAGRAM” section in the CHAPTER 2.

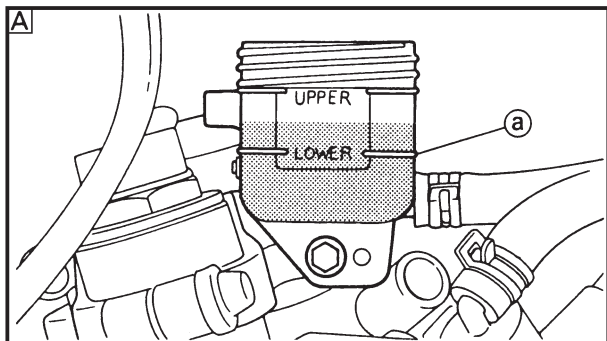

EC5A5610

Brake fluid

1. Fill:
 - Brake fluid
 Until the fluid level reaches “LOWER” level line **a**.



**Recommended brake fluid:
DOT #4**

⚠WARNING _____

- Use only the designated quality brake fluid: otherwise, the rubber seals may deteriorate, causing leakage and poor brake performance.
- Refill with the same type of brake fluid; mixing fluids may result in a harmful chemical reaction and lead to poor performance.
- Be careful that water does not enter the master cylinder when refilling. Water will significantly lower the boiling point of the fluid and may result in vapor lock.

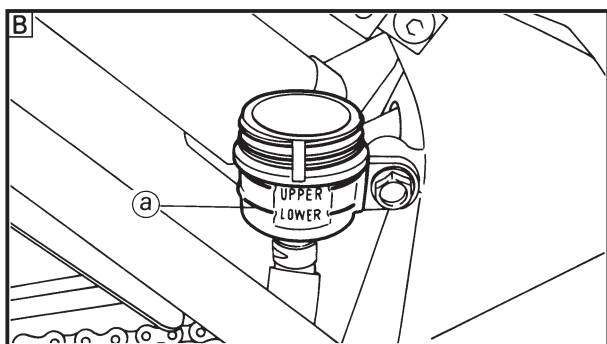

CAUTION: _____

Brake fluid may erode painted surfaces or plastic parts. Always clean up spilled fluid immediately.

A Front

B Rear



2. Air bleed:
 - Brake system
Refer to “BRAKE SYSTEM AIR BLEEDING” section in the CHAPTER 3.
3. Inspect:
 - Brake fluid level
Fluid at lower level → Fill up.
Refer to “BRAKE FLUID LEVEL INSPECTION” section in the CHAPTER 3.

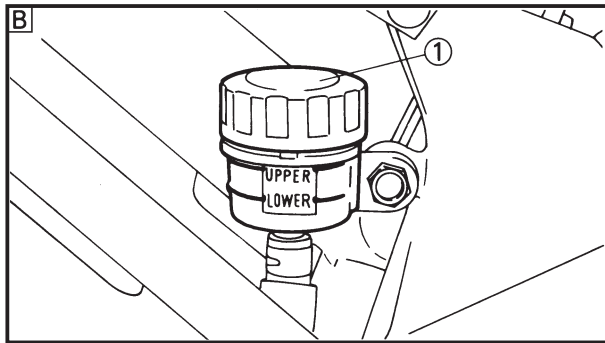
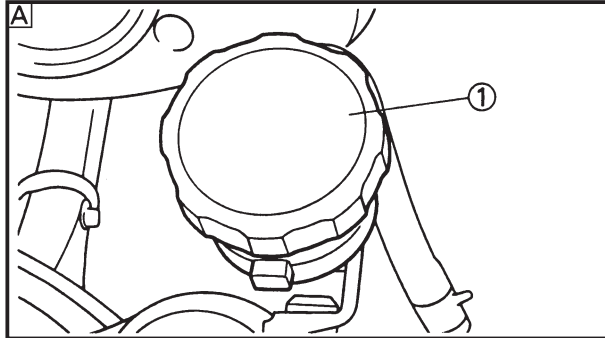

4. Install:
 - Diaphragm
 - Reservoir tank cap ①

CAUTION:

After installation, while pulling the lever in or pushing down on the pedal, check whether there is any brake fluid leaking where the union bolts are installed respectively at the master cylinder and caliper.

- A Front
- B Rear



EC550000

FRONT FORK

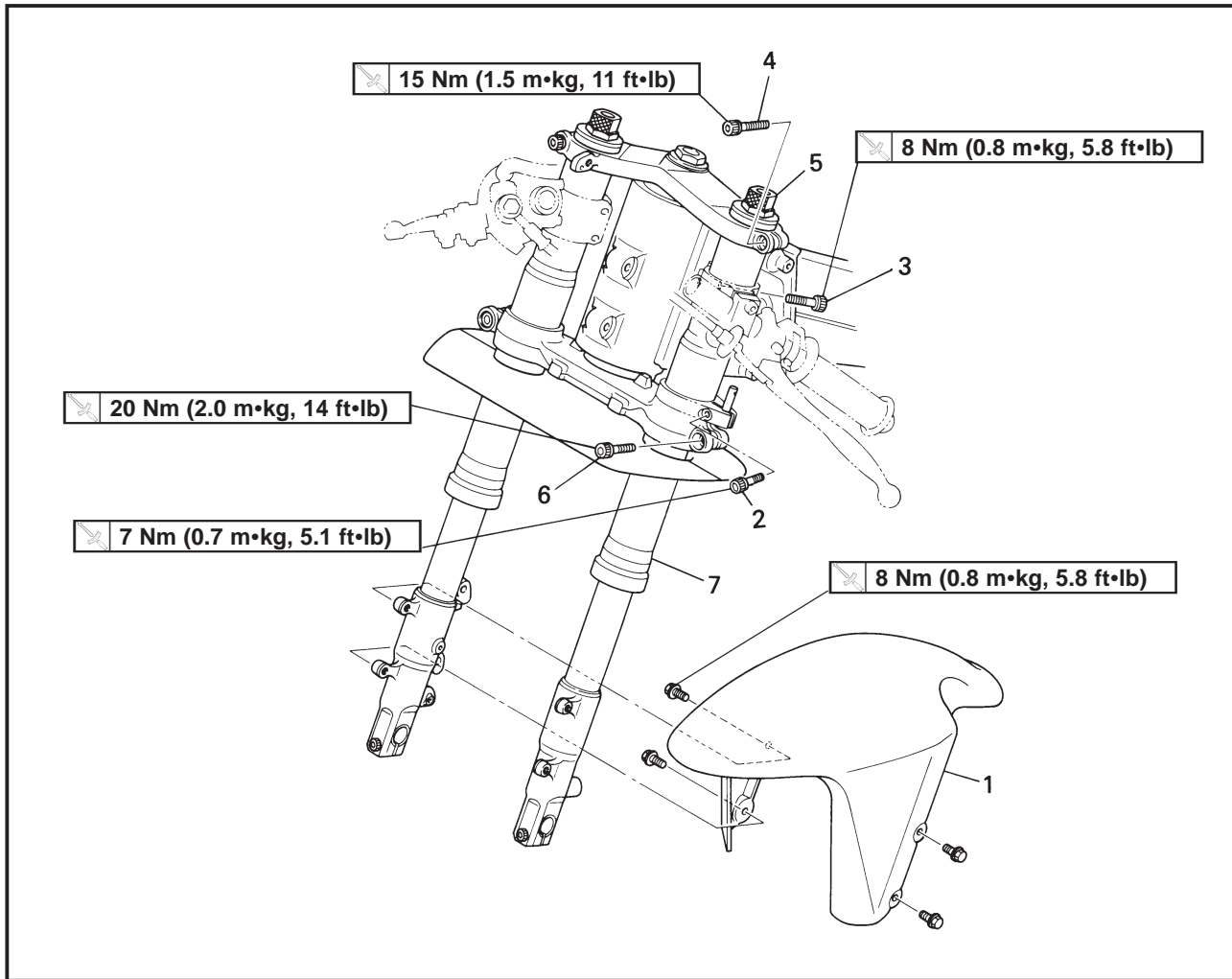

Extend of removal: ① Front fork removal

Extend of removal	Order	Part name	Q'ty	Remarks
Preparation for removal		FRONT FORK REMOVAL Hold the machine by placing the suitable stand. Cowling Front caliper Front wheel Clamp (front brake hose)		⚠WARNING Support the machine securely so there is no danger of it falling over. Refer to "COWLING, SEAT AND FUEL TANK" section in the CHAPTER 4. Refer to "FRONT BRAKE AND REAR BRAKE" section. Refer to "FRONT WHEEL AND REAR WHEEL" section.
↑ ① ↓	1	Front fender	1	
	2	Pinch bolt (steering damper stay)	1	Only loosening. (left side only)
	3	Pinch bolt (handle bracket)	2	Only loosening.
	4	Pinch bolt (handle crown)	1	Only loosening.
	5	Cap bolt	1	Loosen when disassembling the front fork.
	6	Pinch bolt (under bracket)	1	Only loosening.
	7	Front fork	1	

EC558000

FRONT FORK DISASSEMBLY

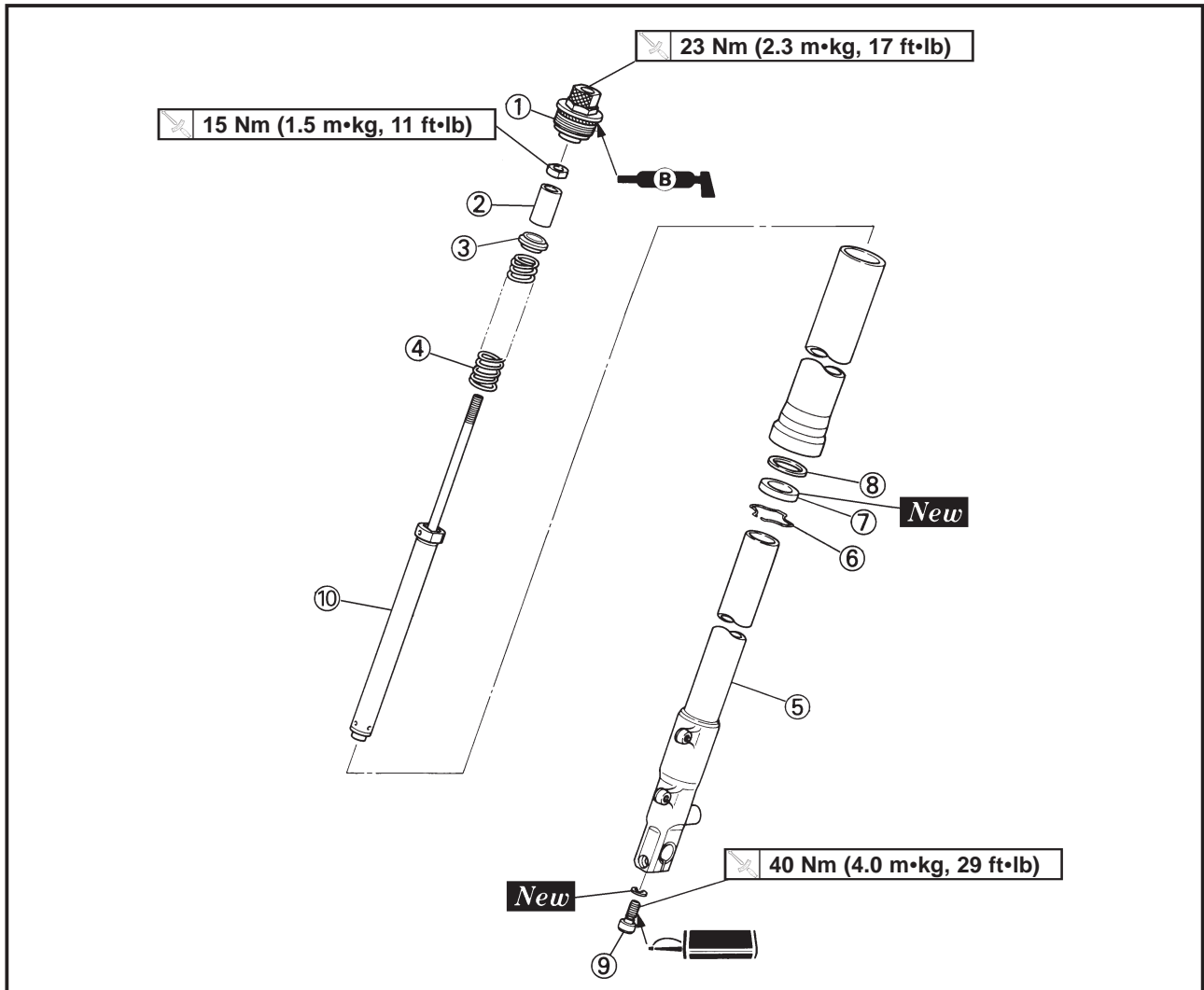

Extend of removal: ① Oil seal removal

② Damper rod removal

Extend of removal	Order	Part name	Q'ty	Remarks	
<div style="display: flex; justify-content: space-around;"> <div style="text-align: center;"> <p>↑</p> <p>①</p> <p>↓</p> </div> <div style="text-align: center;"> <p>↑</p> <p>②</p> <p>↓</p> </div> </div>	FRONT FORK DISASSEMBLY				
	①	Cap bolt	1	Use special tool. Refer to "REMOVAL POINTS".	
	②	Spacer	1		
	③	Spacer guide	1		
	④	Fork spring	1	Drain the fork oil.	
	⑤	Inner tube	1	Refer to "REMOVAL POINTS".	
	⑥	Stopper ring	1		
	⑦	Oil seal	1		
		⑧	Oil seal washer	1	Use special tool. Refer to "REMOVAL POINTS".
		⑨	Bolt (damper rod)	1	
	⑩	Damper rod	1		



EC556000

HANDLING NOTE**NOTE:**

The front fork requires careful attention. So it is recommended that the front fork be maintained at the dealers.

CAUTION:

To prevent an accidental explosion of air, the following instructions should be observed:

- The front fork with a built-in piston rod has a very sophisticated internal construction and is particularly sensitive to foreign material.

Use enough care not to allow any foreign material to come in when the oil is replaced or when the front fork is disassembled and reassembled.

- Before removing the cap bolts or front forks, be sure to extract the air from the air chamber completely.

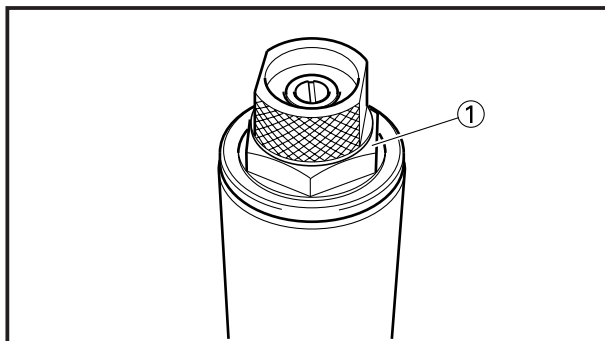

EC553000

REMOVAL POINTS

EC553143

Cap bolt

1. Remove:

- Cap bolt ①
From the outer tube.

NOTE:

Before removing the front fork from the machine, loosen the cap bolt.

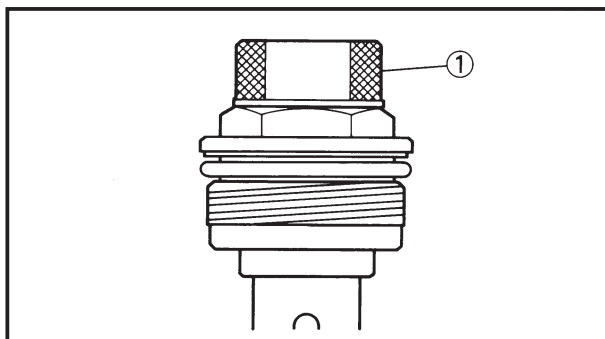

2. Loosen:

- Spring preload adjuster ①

NOTE:

Record the set position of the adjuster (the amount of turning out the adjuster to the fully turned out position) before loosening it.

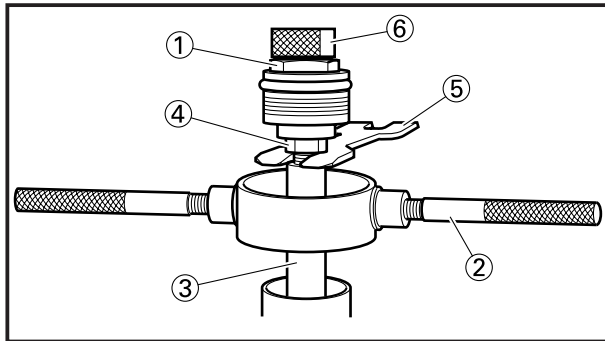

3. Remove:
- Cap bolt ①

NOTE:

- While pressing down the spacer ③ with the fork spring compressor ②, set the rod holder ⑤ between the locknut ④ and spacer.
- Hold the locknut and remove the cap bolt by turning the spring preload adjuster ⑥.



Fork spring compressor:
YM-01441/90890-01441

Rod holder:
YM-01434/90890-01434

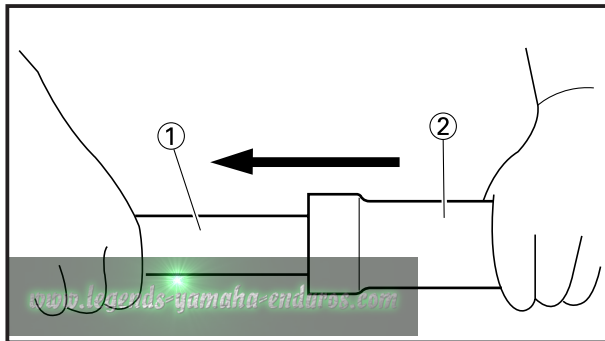

EC553212

Oil seal

1. Remove:
- Inner tube ①
- Pull out the inner tube from the outer tube ②.

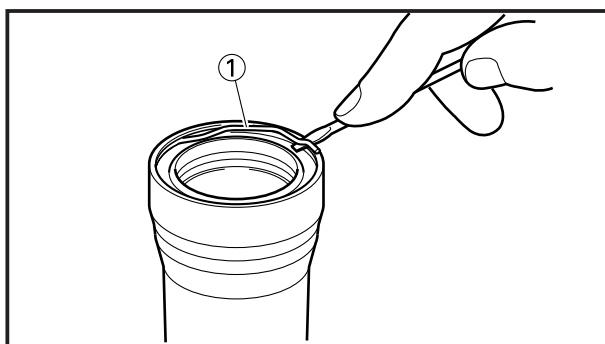

2. Remove:
- Stopper ring ①
- Using slotted-head screwdriver.

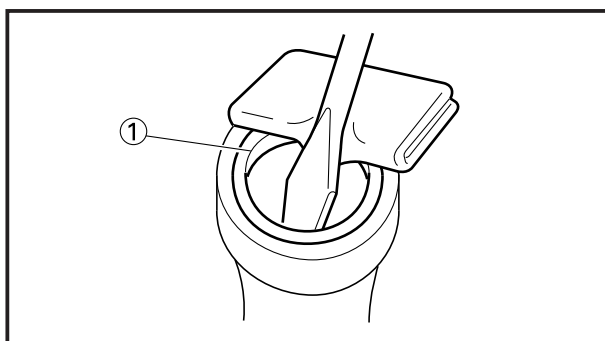

3. Remove:
- Oil seal ①
 - Oil seal washer
- Using slotted-head screwdriver.

CAUTION:

- Take care not to scratch the outer tube inner surface.
- Replace the oil seal whenever removed.

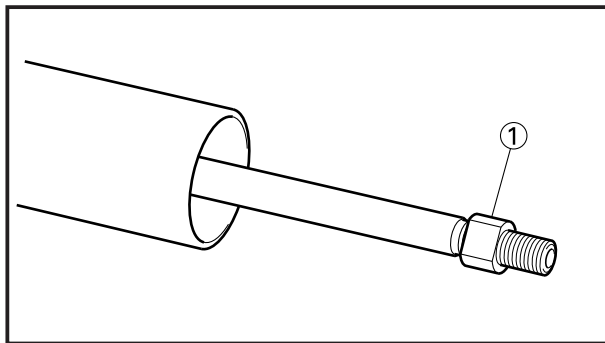

EC553321

Damper rod

1. Remove:
 - Locknut (1)

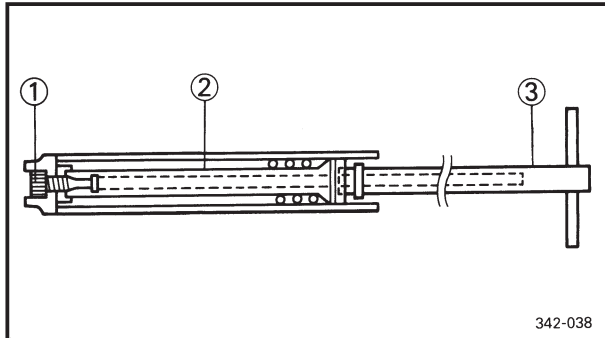

2. Remove:
 - Bolt (damper rod) (1)
 - Damper rod (2)

NOTE:

Use a damper rod holder (3) to lock the damper rod.



Damper rod holder:
YM-01425/90890-01425

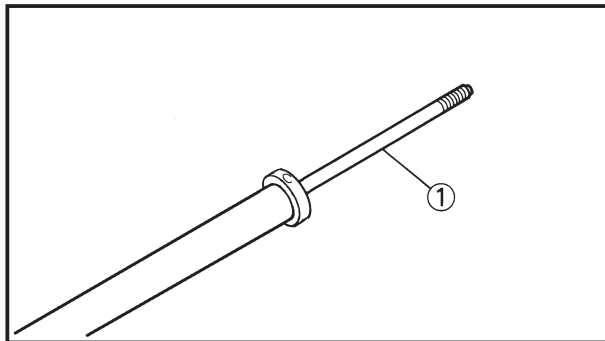

EC554000

INSPECTION

EC554100

Damper rod

1. Inspect:
 - Damper rod (1)
 Bend/Damage → Replace damper rod.

CAUTION:

The front fork with a built-in piston rod has a very sophisticated internal construction and is particularly sensitive to foreign material.

Use enough care not to allow any foreign material to come in when the oil is replaced or when the front fork is disassembled and reassembled.

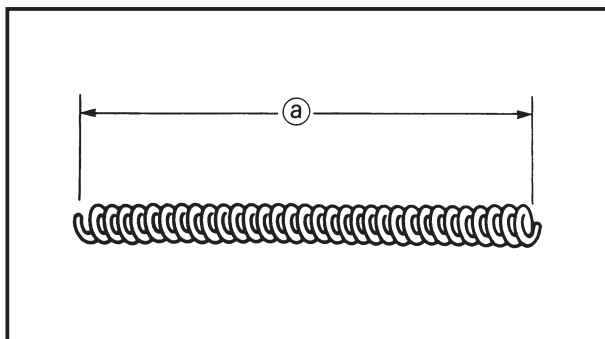

EC554400

Fork spring

1. Measure:
 - Fork spring free length (a)
 Out of specification → Replace.



Fork spring free length:

Standard	Limit
195 mm (7.68 in)	193 mm (7.60 in)

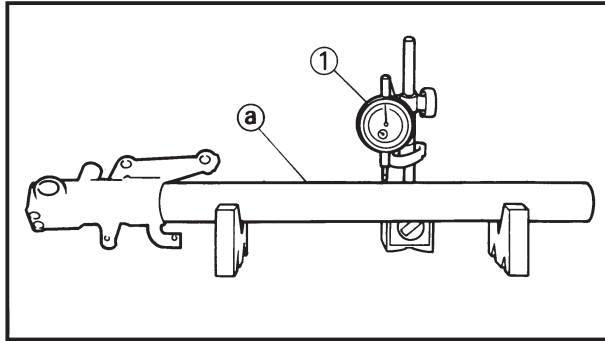

EC554502

Inner tube

1. Inspect:

- Inner tube surface (a)
 - Score marks → Repair or replace.
 - Use #1,000 grit wet sandpaper.
 - Damaged oil lock piece → Replace.
- Inner tube bends
 - Out of specification → Replace.
 - Use the dial gauge (1).



Inner tube bending limit:
0.2 mm (0.008 in)

NOTE:

The bending value is shown by one half of the dial gauge reading.

⚠ WARNING

Do not attempt to straighten a bent inner tube as this may dangerously weaken the tube.

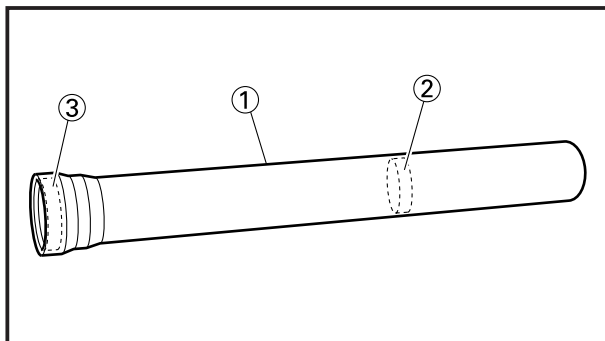

EC554611

Outer tube

1. Inspect:

- Outer tube (1)
- Piston metal (2)
- Slide metal (3)
 - Damage/Score marks/Wear → Replace outer tube assembly.

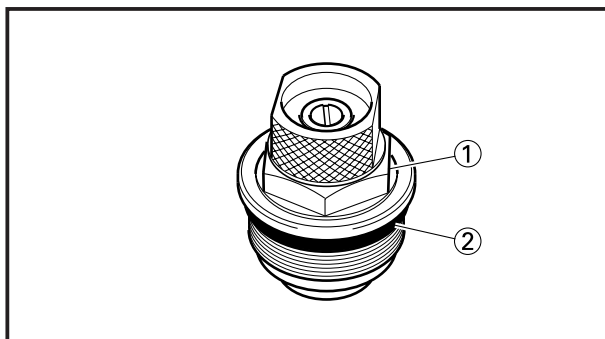

EC554710

Cap bolt

1. Inspect:

- Cap bolt (1)
- O-ring (2)
 - Wear/Damage → Replace.

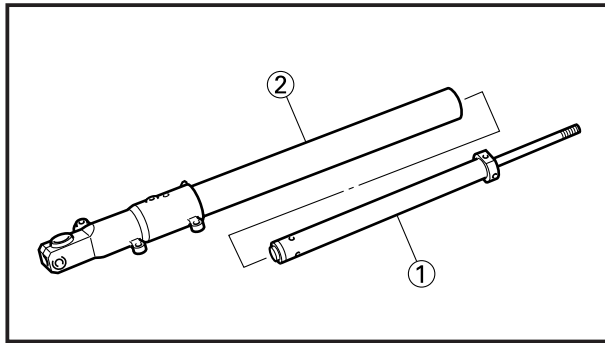

EC555000

ASSEMBLY AND INSTALLATION

EC5551C0

Front fork assembly

1. Wash the all parts in a clear solvent.
2. Install:
 - Damper rod ①
 - To inner tube ②.

CAUTION:

To install the damper rod into the inner tube, hold the inner tube aslant. If the inner tube is held vertically, the damper rod may fall into it, damaging the valve inside.

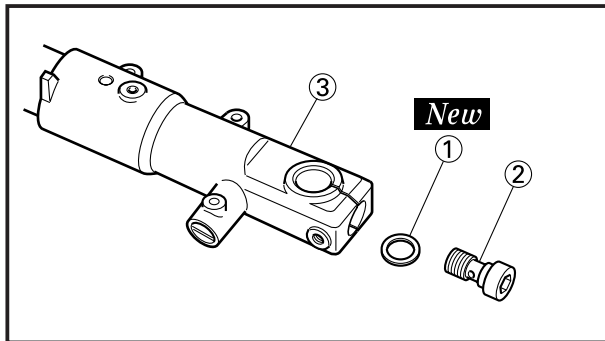

3. Install:
 - Copper washer ① **New**
 - Bolt (damper rod) ②
 - To inner tube ③.

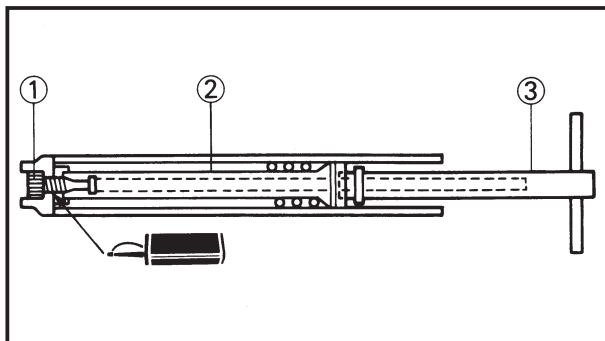

4. Tighten:
 - Bolt (damper rod) ①

40 Nm (4.0 m•kg, 29 ft•lb)
NOTE:

Use a damper rod holder ③ to lock the damper rod ②.

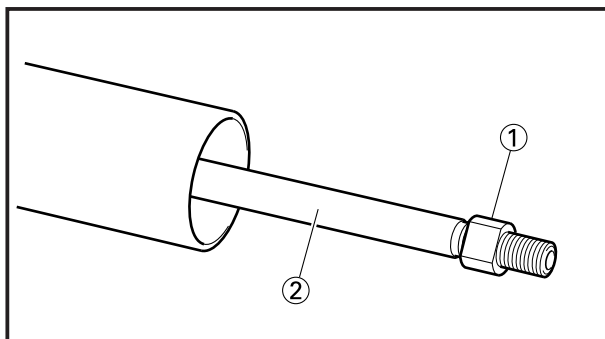
**Damper rod holder:****YM-01425/90890-01425**

5. Install:
 - Locknut ①
 - To damper rod ②.

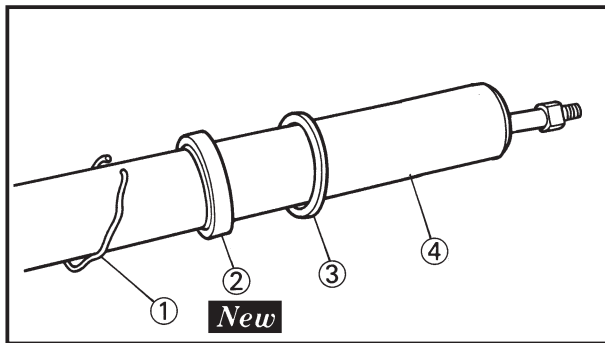

6. Install:
- Stopper ring ①
 - Oil seal ② **New**
 - Oil seal washer ③
 - To inner tube ④.

NOTE:

- Apply the fork oil on the inner tube.
- When installing the oil seal, use vinyl seat (a) with fork oil applied to protect the oil seal lip.
- Install the oil seal with its manufacturer's marks or number facing the axle holder side.

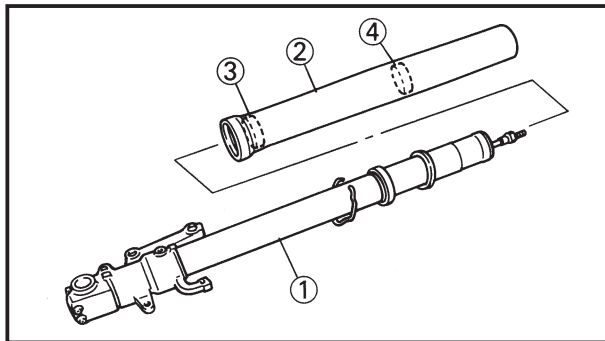
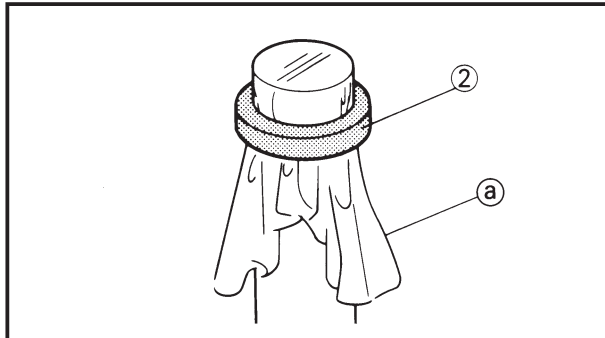

7. Install:
- Inner tube ①
 - To outer tube ②.

CAUTION:

When installing the inner tube, slowly and take care to insert it carefully so that the slide metal ③ and piston metal ④ will not be scratched.

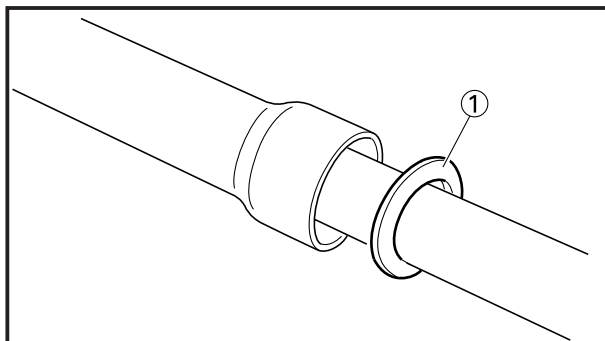

8. Install:
- Oil seal washer ①
 - To outer tube slot.

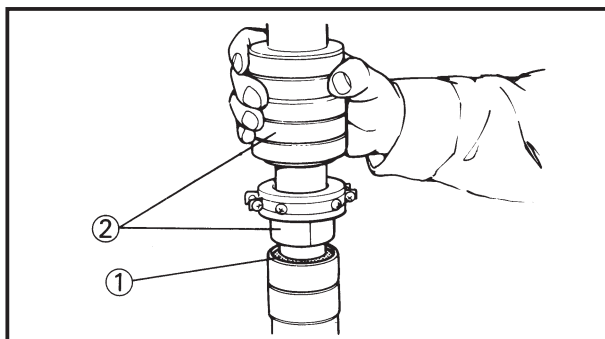

9. Install:
- Oil seal ①

NOTE:

Press the oil seal into the outer tube with fork seal driver ②.



Fork seal driver:

YM-01442/90890-01442

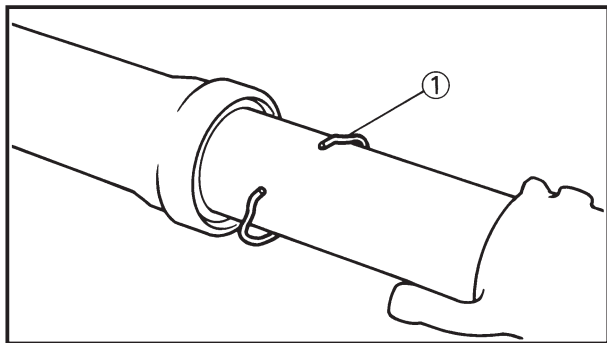

10. Install:
- Stopper ring ①

NOTE: _____

Fit the stopper ring correctly in the groove in the outer tube.

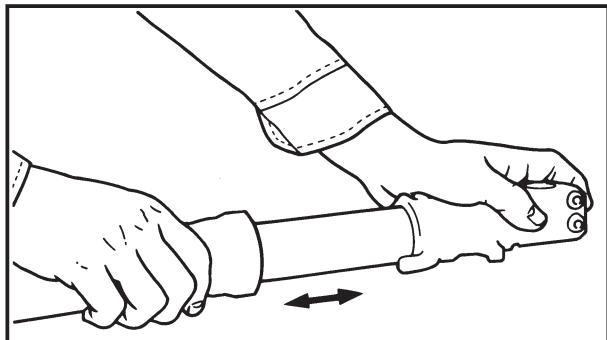

11. Check:
- Inner tube smooth movement
 - Tightness/Binding/Rough spots → Repeat the steps 2 to 10.

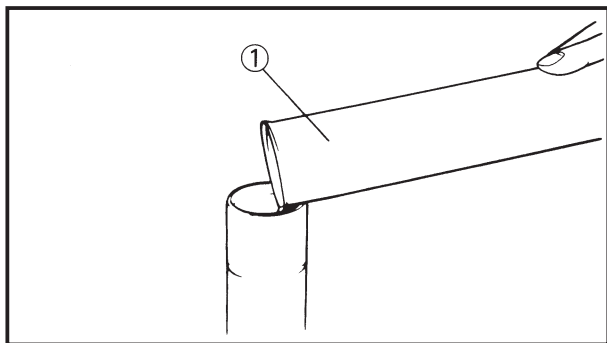

12. Compress the front fork fully.
13. Fill:
- Front fork oil
 - Until outer tube top surface with recommended fork oil ①.



Recommended oil:
Suspension oil "01"

CAUTION: _____

- Be sure to use recommended fork oil. If other oils are used, they may have an excessively adverse effect on the front fork performance.
 - Never allow foreign materials to enter the front fork.
-

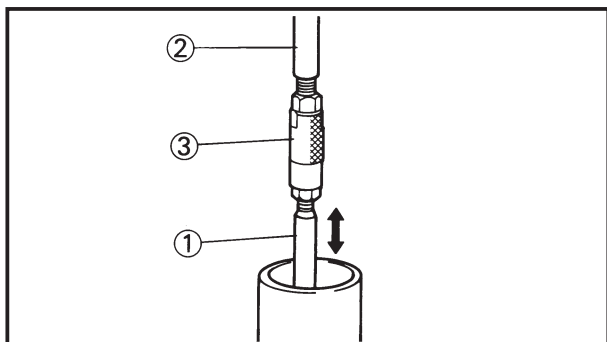

14. After filling, pump the damper rod ① slowly up and down more than 10 times to distribute the fork oil.

NOTE: _____

Use the rod puller ② and rod puller attachment ③ to pull up and down the damper rod.



Rod puller ②:
YM-01437/90890-01437

Rod puller attachment ③:
90890-01436

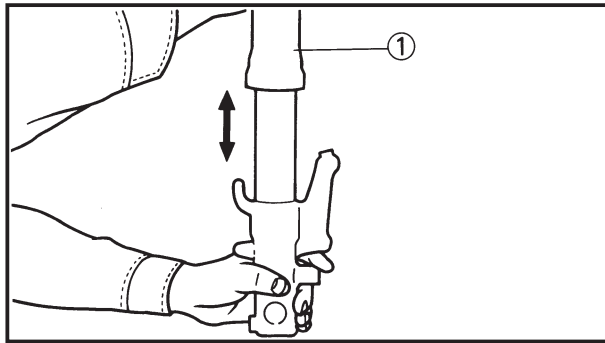

15.Fill:

- Front fork oil

Until outer tube top surface with recommended fork oil once more.

16.After filling, pump the outer tube ① slowly up and down (about 60 mm (2.4 in) stroke) to distribute the fork oil once more.

NOTE:

Be careful not to excessive full stroke. A stroke of 60 mm (2.4 in) or more will cause air to enter. In this case, repeat the steps 13 to 16.

17.Wait ten minutes until the air bubbles have been removed from the front fork, and the oil has dispense evenly in system before setting recommended oil level.

NOTE:

Fill with the fork oil up to the top end of the outer tube, or the fork oil will not spread over to every part of the front forks, thus making it impossible to obtain the correct level. Be sure to fill with the fork oil up to the top of the outer tube and bleed the front forks.

18.Measure:

- Oil level (left and right) ②

Out of specification → Adjust.

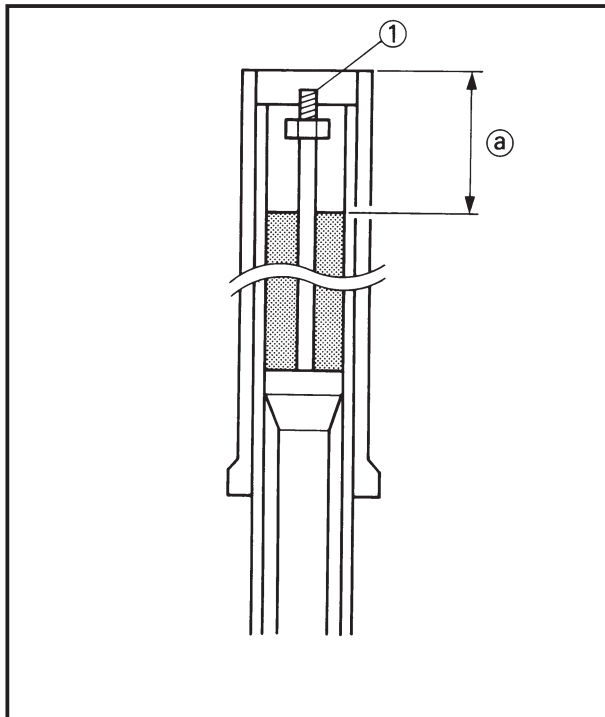

Standard oil level:

110 mm (4.33 in)

Extent of adjustment:

80~140 mm (3.15~5.51 in)

From top of outer tube with inner tube and damper rod ① fully compressed without spring.

⚠WARNING

Never fail to make the oil level adjustment between the maximum and minimum level and always adjust each front fork to the same setting. Uneven adjustment can cause poor handling and loss of stability.

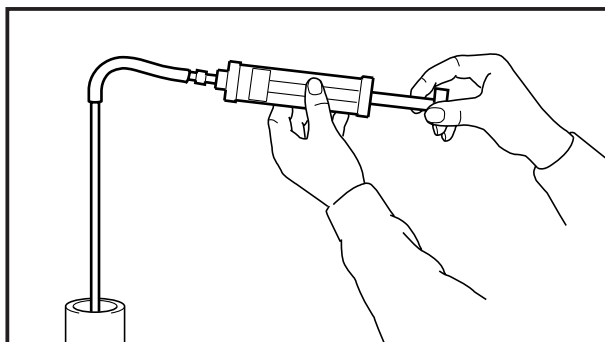

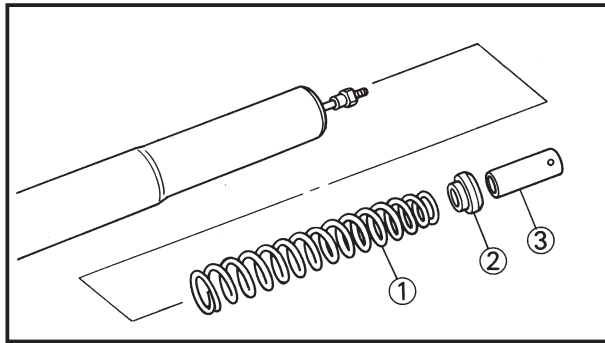

19. Install:

- Fork spring ①
- Spacer guide ②
- Spacer ③

NOTE:

Install the fork spring with its smaller dia. portion upward.

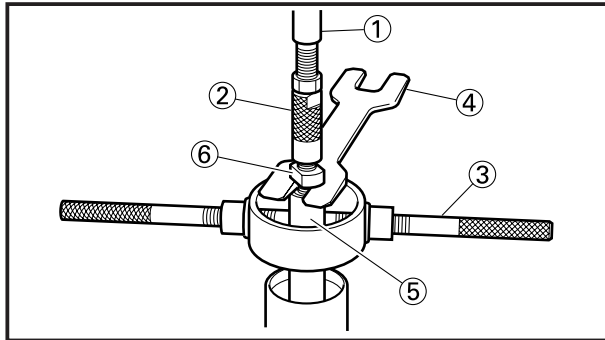

20. Attach:

- Rod puller ①
- Rod puller attachment ②
- Fork spring compressor ③
- Rod holder ④

NOTE:

- Pull up the damper rod with the rod puller and rod puller attachment.
- While pressing down the spacer ⑤ with the fork spring compressor, set the rod holder between the locknut ⑥ and spacer.



Rod puller ①:

YM-01437/90890-01437

Rod puller attachment ②:

90890-01436

Fork spring compressor ③:

YM-01441/90890-01441

Rod holder ④:

YM-01434/90890-01434

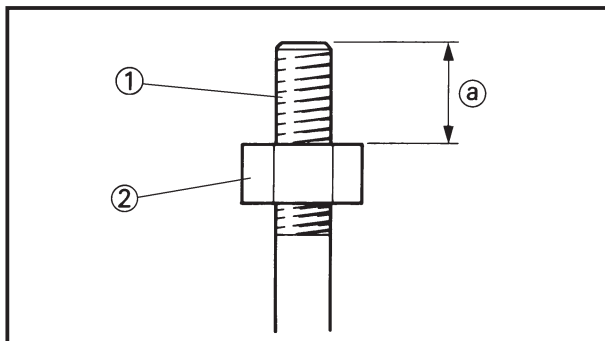

21. Adjust:

- Distance ①
- Out of specification → Turn the locknut ② until the specified distance is obtained.



Distance ①:

13 mm (0.51 in)

Between damper rod ① top and locknut ② top.

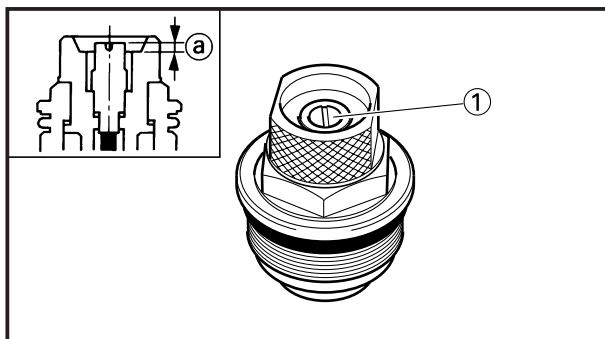

22. Adjust:

- Rebound damping adjuster position ①
- Out of specification → Turn the adjuster ① until the specified position is obtained.



Rebound damping adjuster position ①:

Zero mm (Zero in)



NOTE:

Record the set position of the adjuster (the amount of turning in the adjuster to the fully turned in position) before adjusting it.

CAUTION:

If the rebound damping adjuster position is out of specification, proper damping force cannot be obtained.

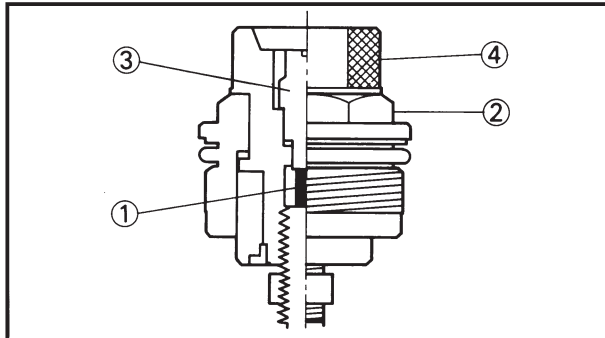

23. Install:

- Push rod ①
- Cap bolt ②

NOTE:

Turn in the cap bolt fully by holding the spring preload adjuster ④ with your hand until the rebound damping adjuster ③ hits the push rod tip.

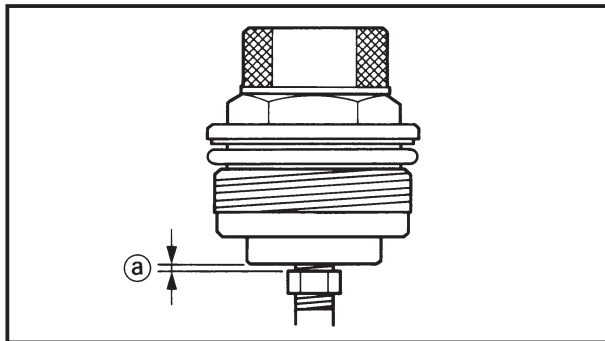

24. Check:

- Cap bolt clearance ①
- Out of specification → Repeat the steps 21 to 23.



Cap bolt clearance ①:
Zero~2 mm (Zero~0.08 in)

CAUTION:

If the cap bolt is installed out of specification, proper damping force cannot be obtained.

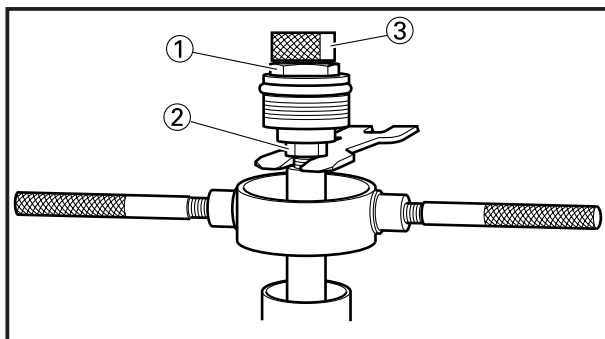

25. Install:

- Cap bolt (locknut) ①

15 Nm (1.5 m•kg, 11 ft•lb)

NOTE:

Hold the locknut ② and tighten the cap bolt by turning the spring preload adjuster ③ with specified torque.

CAUTION:

Do not tighten the cap bolt. It may cause damage to the spring preload adjuster.

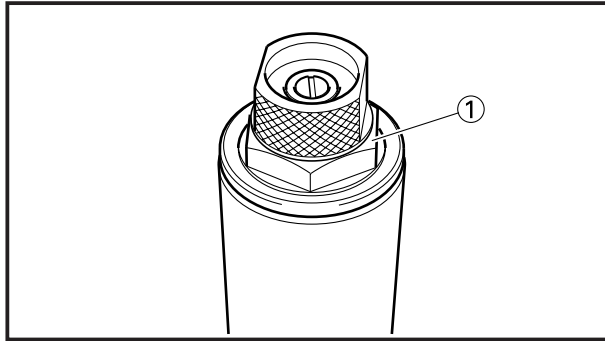

26. Install:
- Cap bolt ①
To outer tube.

NOTE: _____
Temporarily tighten the cap bolt.

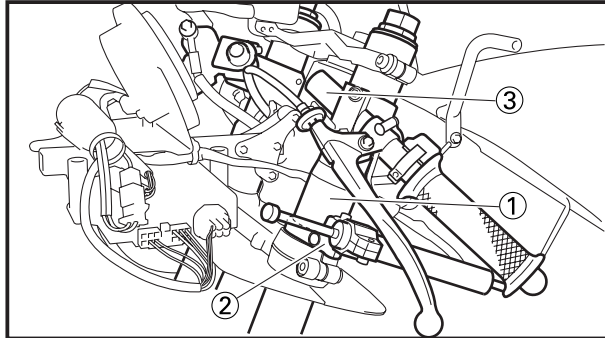

EC555263

Installation

1. Install:
- Front fork ①
 - Steering damper stay ② (left side only)
 - Handlebar ③

NOTE: _____
• Temporarily tighten the pinch bolt (under bracket).
• Do not tighten the pinch bolts (handle crown, steering damper stay and handle bracket) yet.

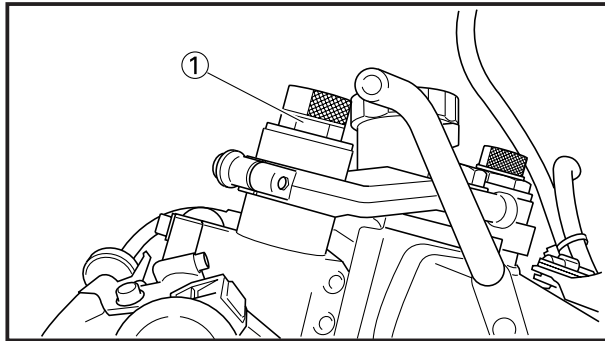

2. Tighten:
- Cap bolt ① 23 Nm (2.3 m•kg, 17 ft•lb)

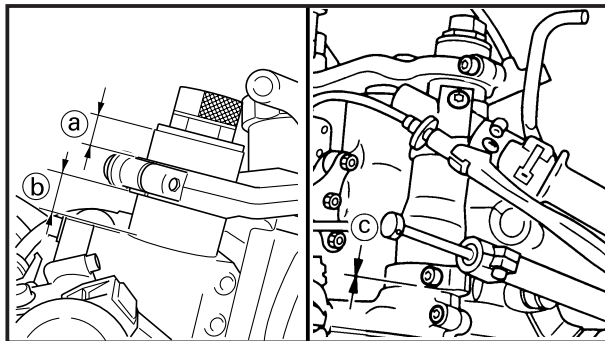

3. Adjust:
- Front fork top end ①
 - Handlebar position ②
 - Steering damper stay position ③ (left side only)



Front fork top end:
18 mm (0.71 in)
Handlebar position:
20 mm (0.79 in)
Steering damper stay position:
Zero mm (Zero in)

Refer to "FRONT FORK TOP END ADJUSTMENT" in the CHAPTER 3.

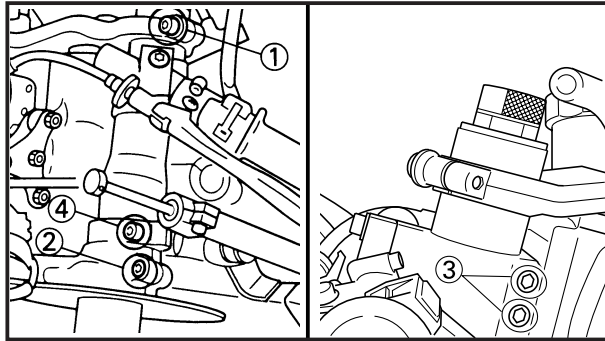

4. Tighten:

- Pinch bolt (handle crown) ①
15 Nm (1.5 m•kg, 11 ft•lb)
- Pinch bolt (under bracket) ②
20 Nm (2.0 m•kg, 14 ft•lb)
- Pinch bolt (handle bracket) ③
8 Nm (0.8 m•kg, 5.8 ft•lb)
- Pinch bolt (steering damper stay) ④ (left side only)
7 Nm (0.7 m•kg, 5.1 ft•lb)

Refer to “FRONT FORK TOP END ADJUSTMENT” in the CHAPTER 3.

5. Check:

- Steering smooth action
 Turn the handlebar to make sure no parts are being contacted with others.
 Contact → Repair.

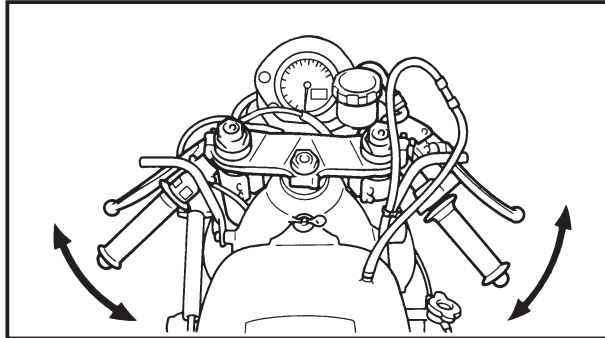

6. Adjust:

- Rebound damping force
- Spring preload

NOTE:

- Turn in the rebound damping adjuster ① fully, then turn out it to the originally set position.
- Turn in the spring preload adjuster ② to the originally set position.

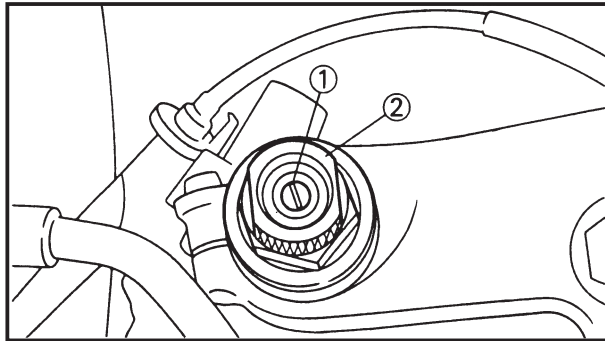

7. Install:

- Front fender ①
- Bolt (front fender) ②

8 Nm (0.8 m•kg, 5.8 ft•lb)

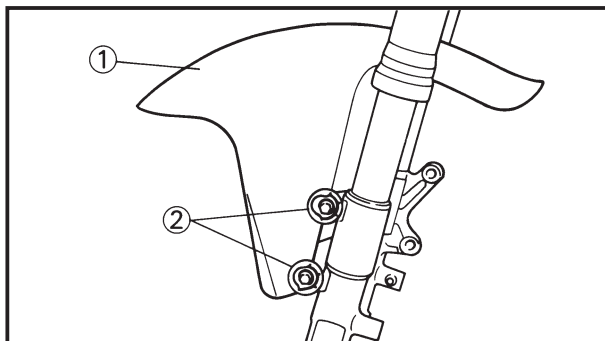



EC5B0000

HANDLEBAR

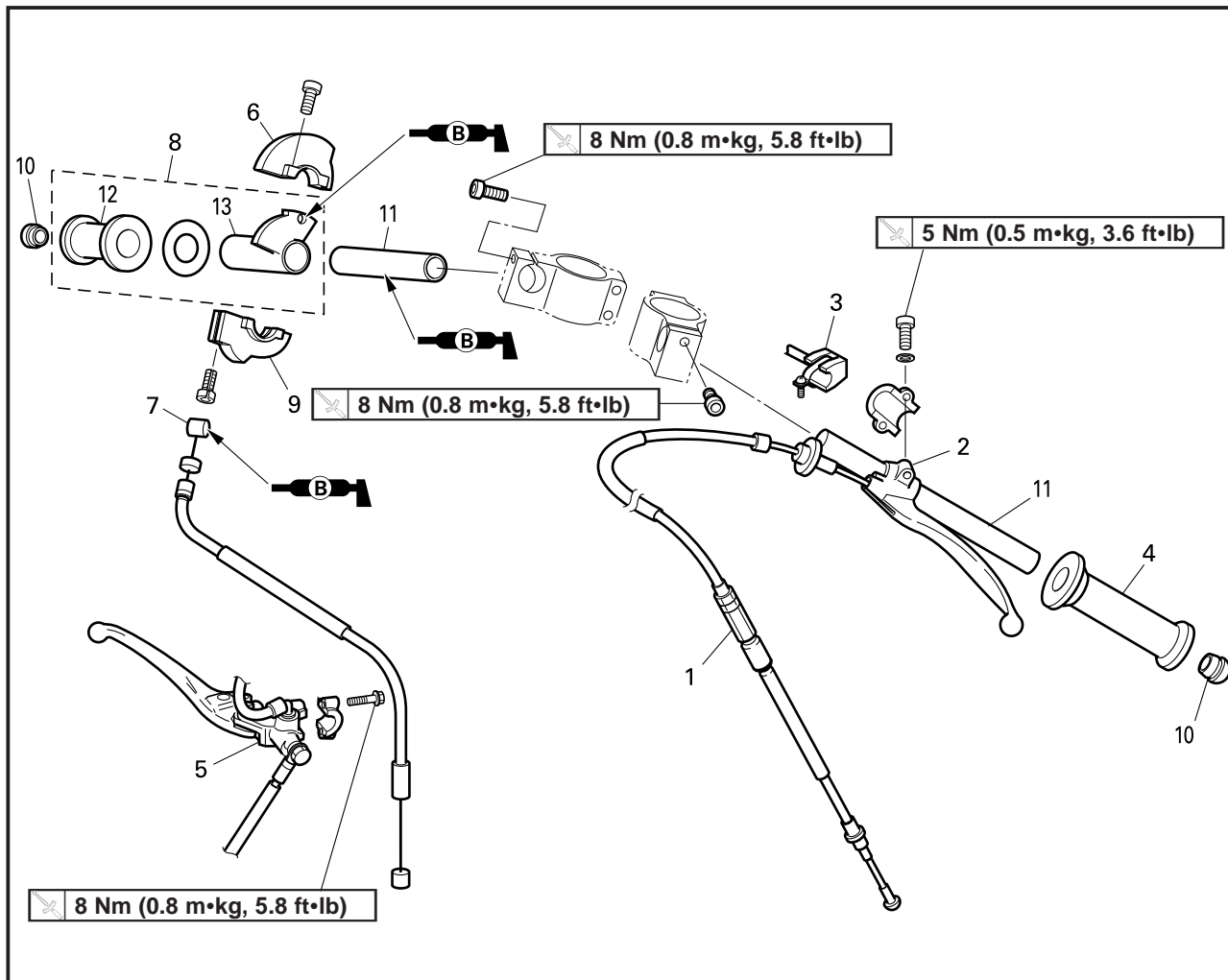

Extend of removal: ① Handlebar removal ② Throttle disassembly

Extend of removal	Order	Part name	Q'ty	Remarks
Preparation for removal		HANDLEBAR REMOVAL Cowling		Refer to "COWLING, SEAT AND FUEL TANK" section in the CHAPTER 4.
	1	Clutch cable	1	Disconnect at the lever side.
	2	Clutch lever holder	1	
	3	"ENGINE STOP" button	1	Refer to "REMOVAL POINTS".
	4	Grip (left)	1	
	5	Master cylinder	1	
	6	Grip cap (upper)	1	
	7	Throttle cable	1	
	8	Throttle	1	
	9	Grip cap (lower)	1	
	10	Grip end	2	
	11	Handlebar	2	
	12	Grip (right)	1	
	13	Tube guide	1	Refer to "REMOVAL POINTS".

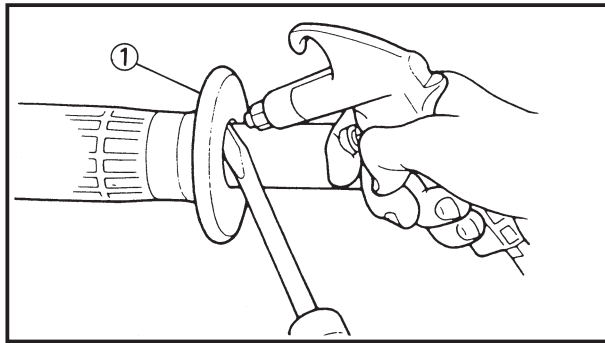

EC5B3000

REMOVAL POINTS

EC5B3200

Grip

- Remove:
 - Grip ①

NOTE:

Blow in air between the handlebar or tube guide and the grip. Then remove the grip which has become loose.

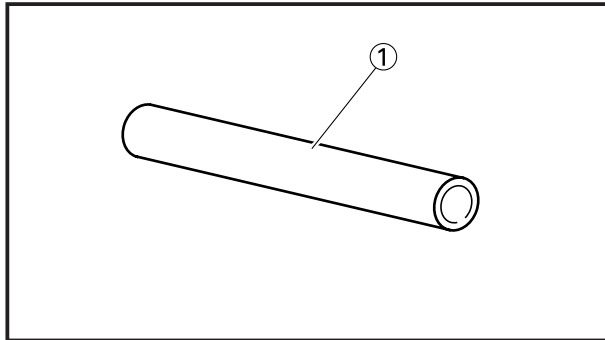

EC5B4000

INSPECTION

EC5B4100

Handlebar

- Inspect:
 - Handlebar ①
 Bends/Cracks /Damage → Replace.

⚠WARNING

Do not attempt to straighten a bent handlebar as this may dangerously weaken the handlebar.

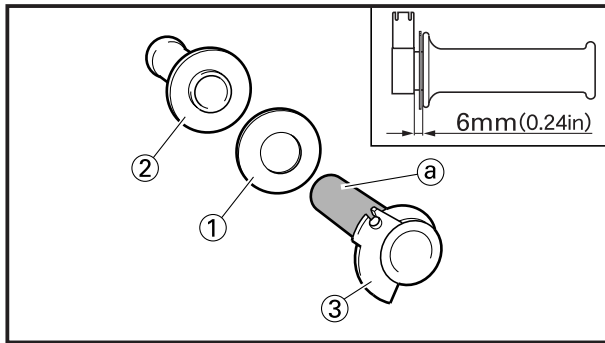

EC5B5000

ASSEMBLY AND INSTALLATION

EC5B5110

Throttle assembly

- Install:
 - Ring plate ①
 - Grip (right) ②
 Apply the adhesive on the tube guide ③.

NOTE:

Before applying the adhesive, wipe off grease or oil on the tube guide surface ③ with a lacquer thinner.

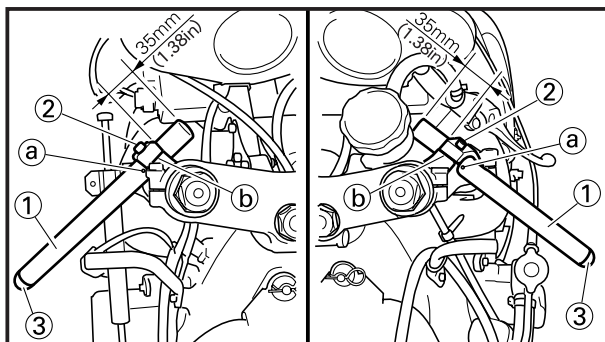

EC5B5220

Handlebar

- Install:
 - Handlebar ①
 - Bolt (handlebar) ②

8 Nm (0.8 m•kg, 5.8 ft•lb)

NOTE:

Align the punch mark ① on the handlebar with the slit ② in the handlebar bracket.

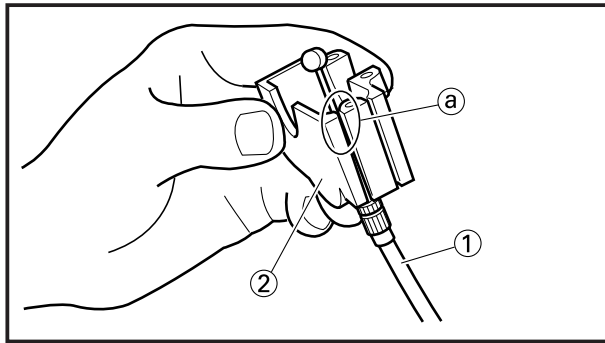

2. Install:
- Throttle cable ①
 - To grip cap (lower) ②.

NOTE:

Install the throttle cable in the grip side slit (a) in the grip cap (lower).

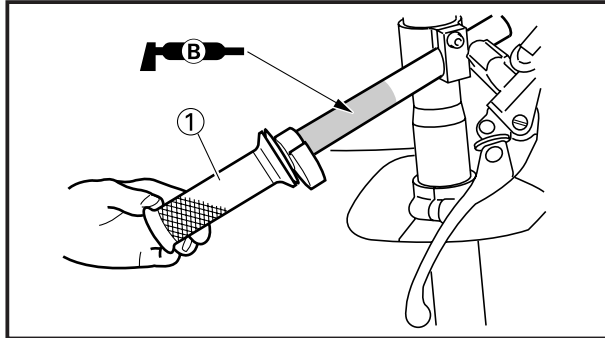

3. Install:
- Throttle ①

NOTE:

Apply the lithium soap base grease on the throttle grip sliding surface.

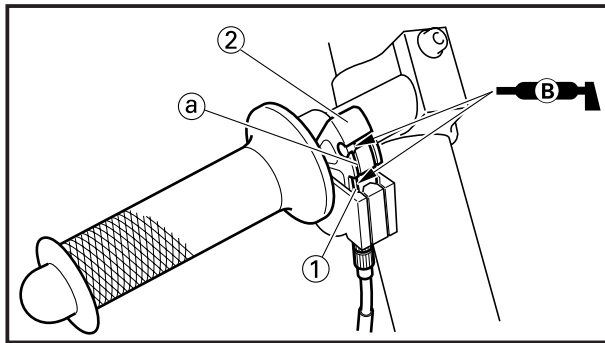

4. Install:
- Throttle cable ①
 - To tube guide ②.

NOTE:

- Apply the lithium soap base grease on the throttle cable end and tube guide cable widening portion.
- Install the throttle cable in the grip side slit (a) in the tube guide.

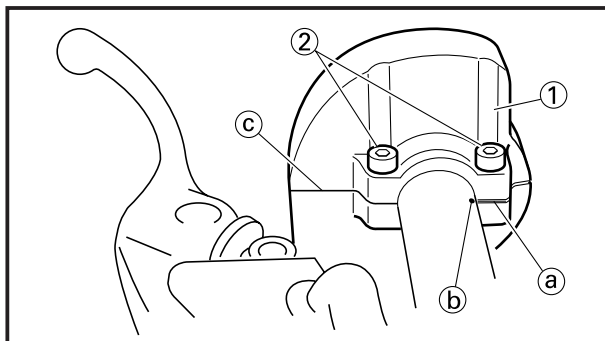

5. Install:
- Grip cap (upper) ①
 - Bolt (grip cap) ②

NOTE:

- Align the contacting surface (a) of the grip cap (upper) with the punch mark (b) on the handlebar.
- Tighten the bolts so that the front side contacting surface (c) is closed.

6. Adjust:
- Throttle grip free play
- Refer to "THROTTLE CABLE ADJUSTMENT" section in the CHAPTER 3.

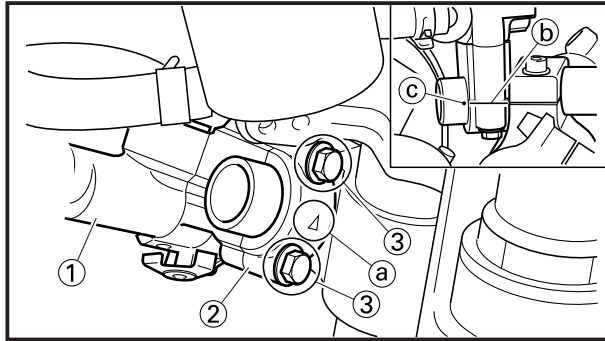

7. Install:

- Master cylinder ①
- Master cylinder bracket ②
- Bolt (master cylinder bracket) ③

8 Nm (0.8 m•kg, 5.8 ft•lb)

NOTE:

- Install the bracket so that the arrow mark ② faces upward.
- When installing master cylinder, align the contacting surface ⑥ of the master cylinder bracket with the punch mark ③ on the handlebar.

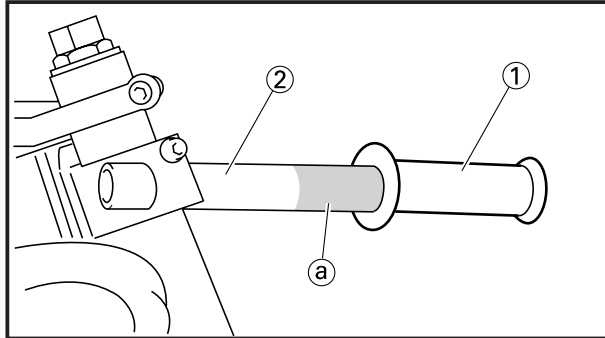

8. Install:

- Grip (left) ①
- Apply the adhesive to the handlebar ②.

NOTE:

Before applying the adhesive, wipe off grease or oil on the handlebar surface ② with a lacquer thinner.

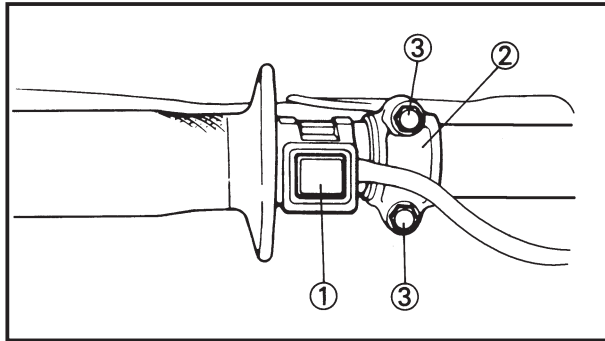

9. Install:

- "ENGINE STOP" button ①
- Clutch lever holder ②
- Bolt (clutch lever holder) ③

5 Nm (0.5 m•kg, 3.6 ft•lb)

NOTE:

The "ENGINE STOP" button and clutch lever holder should be installed according to the dimensions shown.

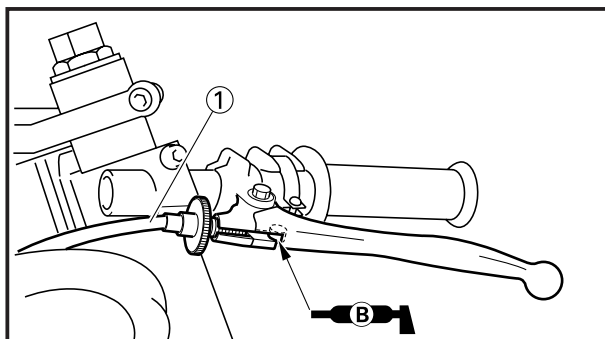
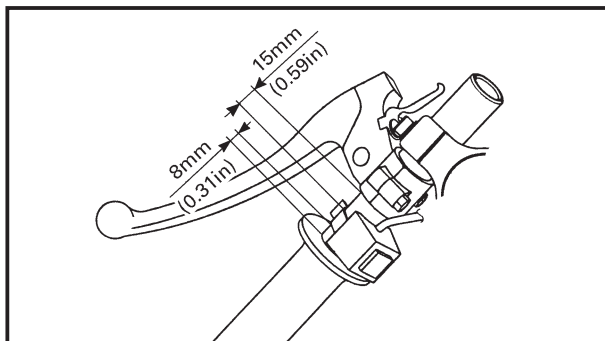

10. Install:

- Clutch cable ①

NOTE:

Apply the lithium soap base grease on the clutch cable end.



11. Adjust:

- Clutch lever free play

Refer to “CLUTCH ADJUSTMENT” section in the CHAPTER 3.

12. Lock the throttle cables using a locking wire.

Refer to “LOCKING WIRE INSTALLATION GUIDE” section in the CHAPTER 3.



EC560000

STEERING

EC568000

HANDLE CROWN AND STEERING DAMPER

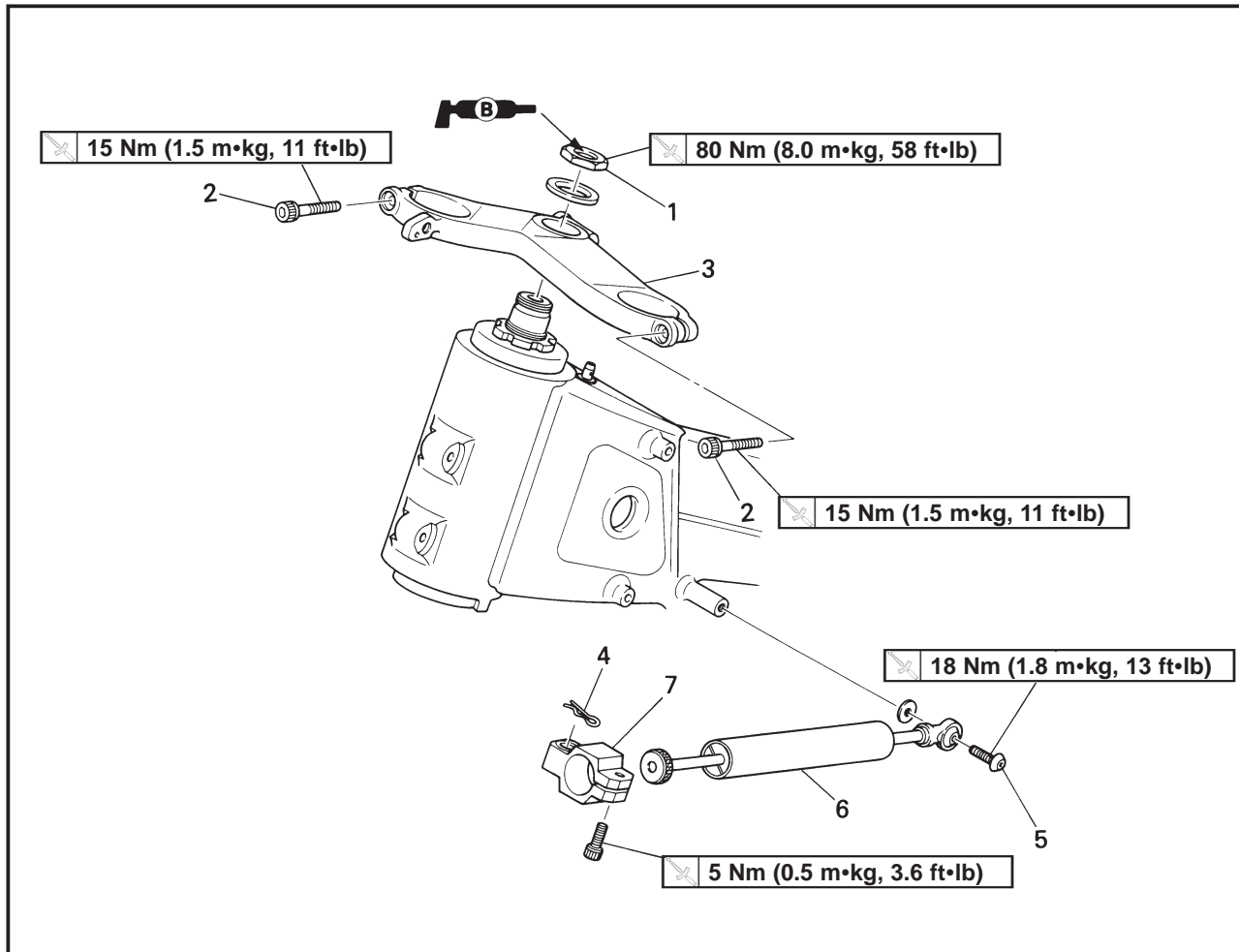

Extend of removal: ① Handle crown removal ② Steering damper removal

Extend of removal	Order	Part name	Q'ty	Remarks
Preparation for removal		HANDLE CROWN AND STEERING DAMPER REMOVAL Hold the machine by placing the suitable stand.		<p>▲WARNING _____ Support the machine securely so there is no danger of it falling over.</p> <p>Refer to "COWLING, SEAT AND FUEL TANK" section in the CHAPTER 4.</p> <p>Refer to "FRONT BRAKE AND REAR BRAKE" section.</p> <p>Refer to "FRONT WHEEL AND REAR WHEEL" section.</p>
		Cowling		
		Bolt (Front brake reservoir tank)		
		Front brake caliper		
		Front wheel		
		Front fender		
①	1	Steering shaft nut	1	Only loosening.
	2	Pinch bolt (handle crown)	2	
	3	Handle crown	1	
	4	Clip	1	
	5	Bolt (steering damper)	1	
	6	Steering damper	1	
	7	Steering damper bracket	1	



EC568100

UNDER BRACKET

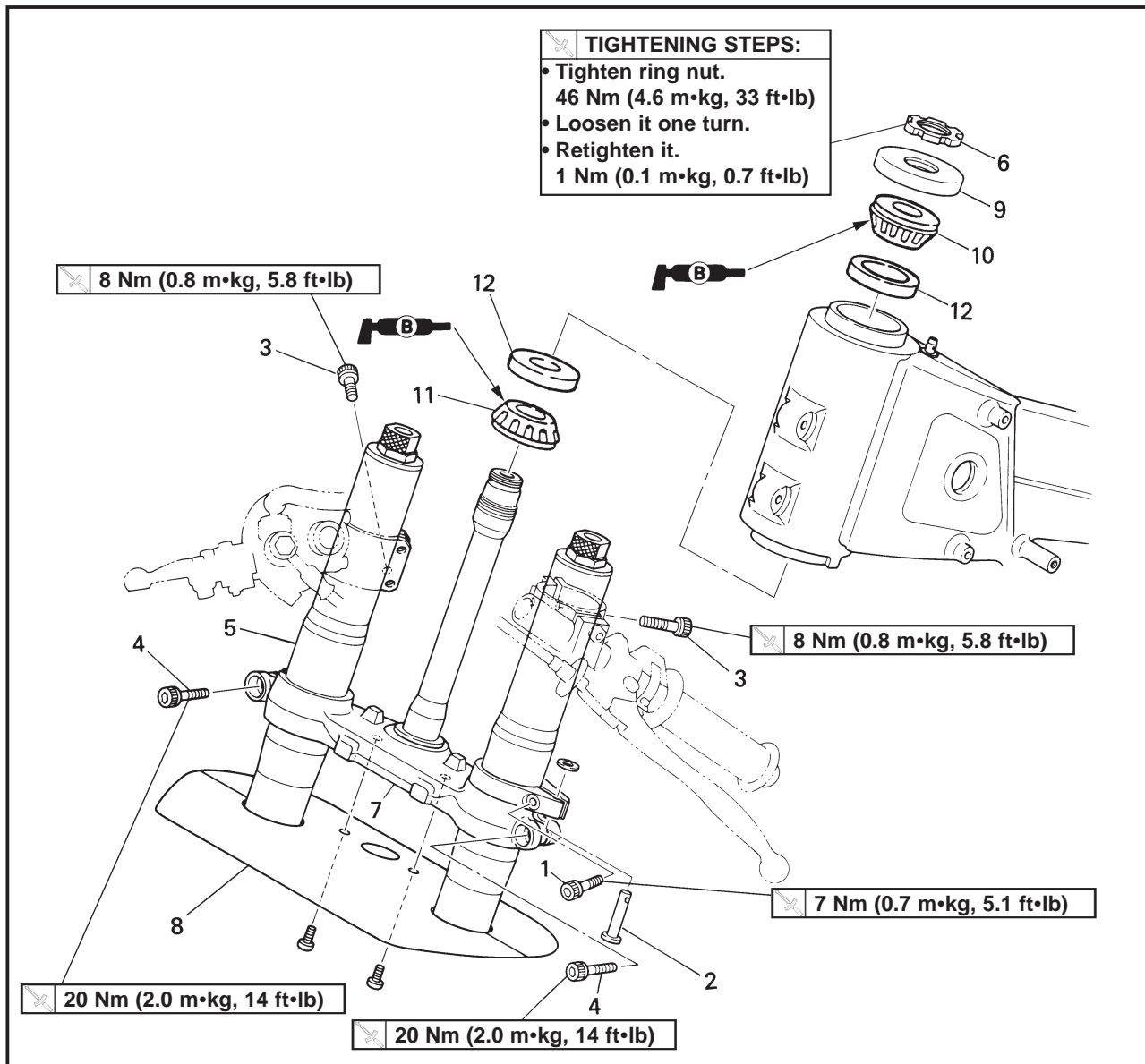

Extend of removal: ① Under bracket removal ② Bearing removal

Extend of removal	Order	Part name	Q'ty	Remarks
<div style="display: flex; justify-content: space-around;"> <div style="text-align: center;"> <p>①</p> </div> <div style="text-align: center;"> <p>②</p> </div> </div>	UNDER BRACKET REMOVAL			
	1	Pinch bolt (steering damper stay)	1	Only loosening.
	2	Pin	1	
	3	Pinch bolt (handle bracket)	4	Only loosening.
	4	Pinch bolt (under bracket)	2	Only loosening.
	5	Front fork	2	Refer to "FRONT FORK" section.
	6	Ring nut	1	Use special tool. Refer to "REMOVAL POINTS".
	7	Under bracket	1	
	8	Inner fender	1	
	9	Ball race cover	1	
	10	Bearing (upper)	1	
	11	Bearing (lower)	1	Refer to "REMOVAL POINTS".
12	Ball race	2	Refer to "REMOVAL POINTS".	

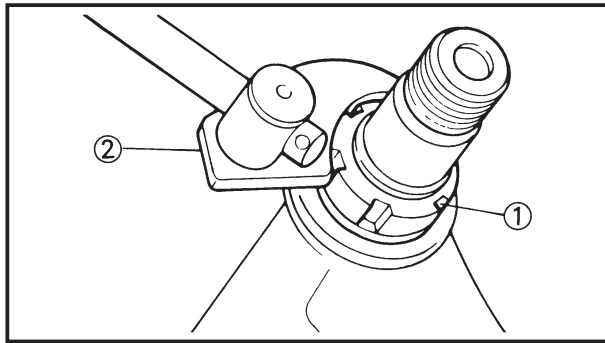

EC563000

REMOVAL POINTS

EC563202

Ring nut

1. Remove:
 - Ring nut ①
 - Use the ring nut wrench ②.



Ring nut wrench:

YM-33975/90890-01403

⚠WARNING

Support the steering shaft so that it may not fall down.

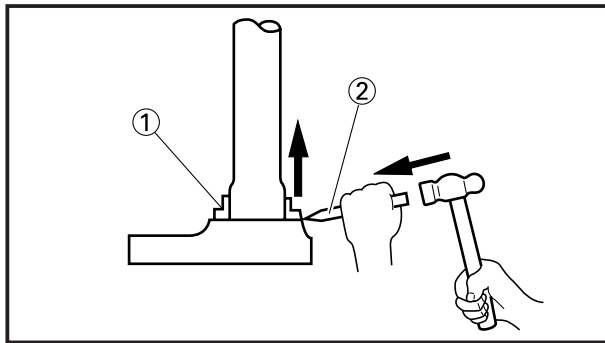

EC563300

Bearing (lower)

1. Remove:
 - Bearing (lower) ①
 - Use the floor chisel ②.

CAUTION:

Take care not to damage the steering shaft thread.

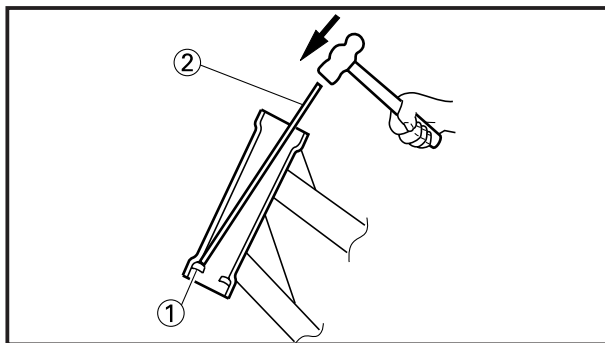

EC563400

Ball race

1. Remove:
 - Ball race ①
 - Remove the ball race using long rod ② and the hammer.

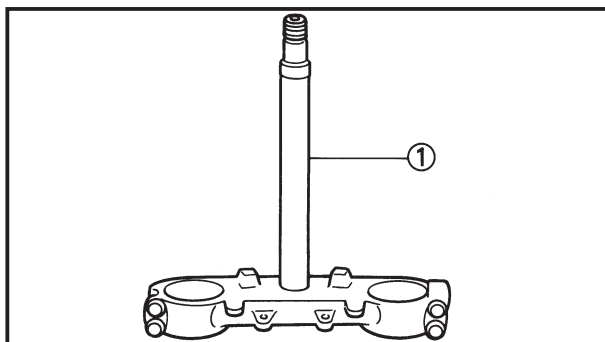

EC564000

INSPECTION

EC564200

Steering shaft

1. Inspect:
 - Steering shaft ①
 - Bend/Damage → Replace.

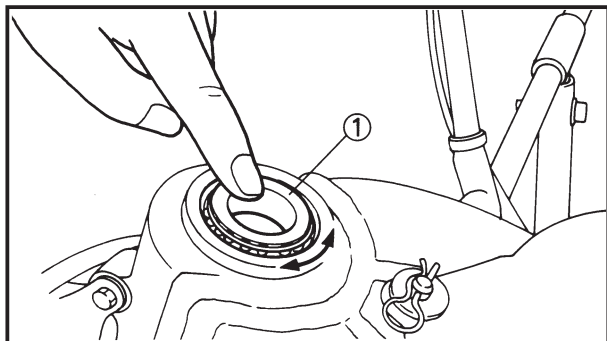

EC564101

Bearing and ball race

1. Wash the bearings and ball races with a solvent.
2. Inspect:
 - Bearing ①
 - Ball race
 Pitting/Damage → Replace bearings and ball races as a set.
 Install the bearing in the ball races. Spin the bearings by hand. If the bearings hang up or are not smooth in their operation in the ball races, replace bearings and ball races as a set.

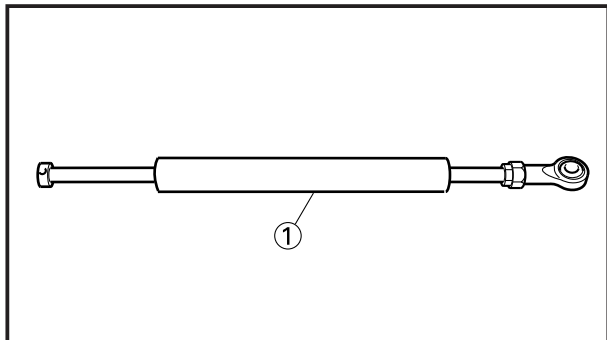

EC564300

Steering damper

1. Inspect:
 - Steering damper ①
 Bend/Damage → Replace.
 Oil leaks/Unsmooth movement → Replace.

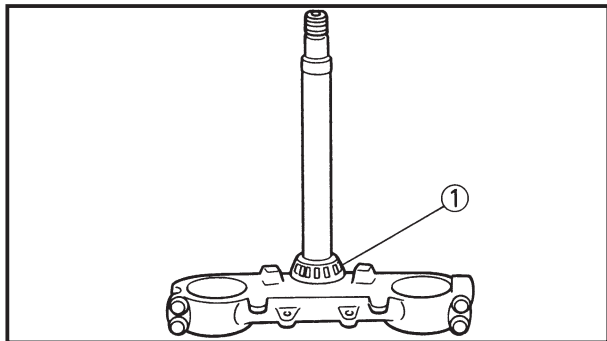

EC565000

ASSEMBLY AND INSTALLATION

EC565182

Under bracket

1. Install:
 - Bearing (lower) ①

NOTE: _____
 Apply the lithium soap base grease on the dust seal lip and bearing inner circumference.

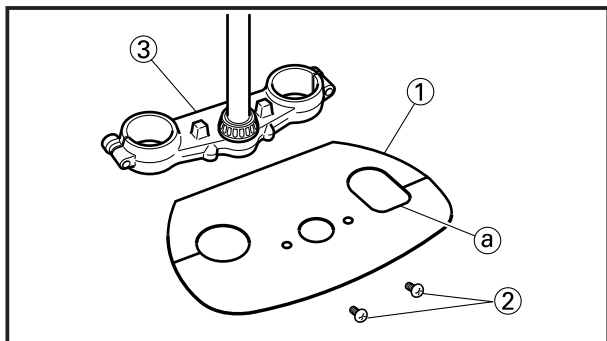

2. Install:
 - Inner fender ①
 - Screw (inner fender) ②
 To under bracket ③.

NOTE: _____
 Install the inner fender with its large hole (a) facing to the right.

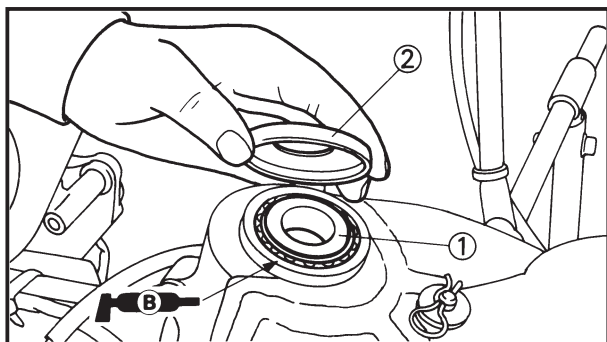

3. Install:
 - Ball race
 - Bearing ①
 - Ball race cover ②

NOTE: _____
 Apply the lithium soap base grease on the bearing.

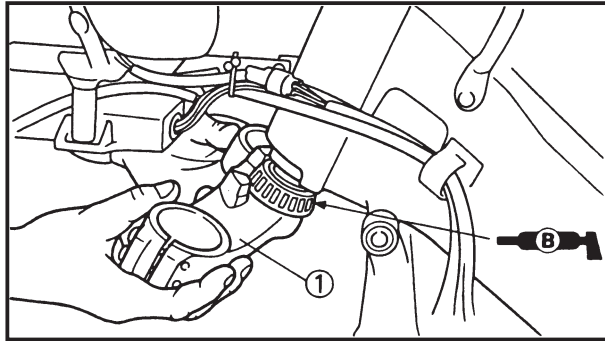

4. Install:
- Under bracket ①

NOTE:

Apply the lithium soap base grease on the bearing.

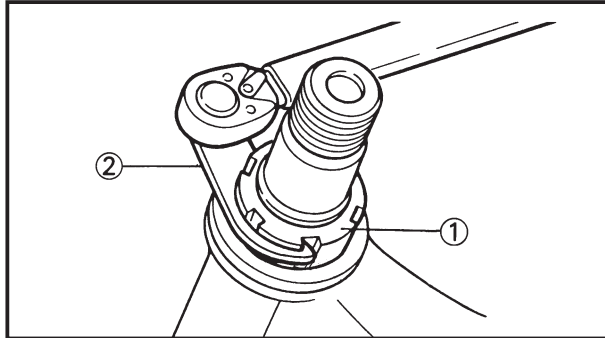

5. Install:

- Ring nut ① 1 Nm (0.1 m•kg, 0.7 ft•lb)

Tighten the ring nut using the ring nut wrench ②.

Refer to “STEERING HEAD INSPECTION AND ADJUSTMENT” section in the CHAPTER 3.

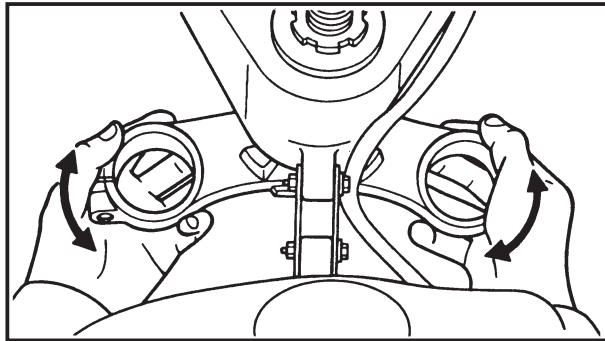

6. Check the steering shaft by turning it lock to lock. If there is any binding, remove the steering shaft assembly and inspect the steering bearings.

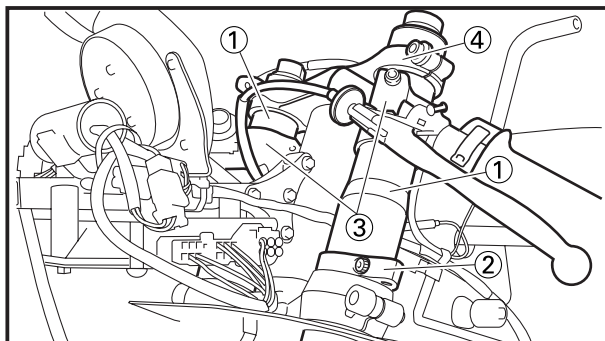

7. Install:

- Front fork ①
- Steering damper stay ② (left side only)
- Handlebar ③
- Handle crown ④

NOTE:

- Temporarily tighten the pinch bolt (under bracket).
- Do not tighten the pinch bolts (handle crown, steering damper stay and handle bracket) yet.

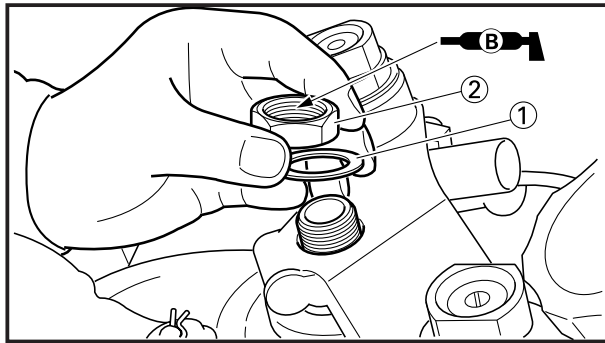

8. Install:
- Plain washer ①
 - Steering shaft nut ②

80 Nm (8.0 m•kg, 58 ft•lb)

NOTE: _____

Apply the lithium soap base grease on the steering shaft nut thread.

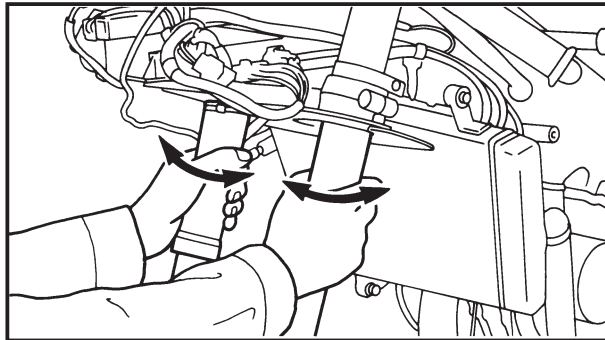

9. After tightening the nut, check the steering for smooth movement. If not, adjust the steering by loosening the ring nut little by little.

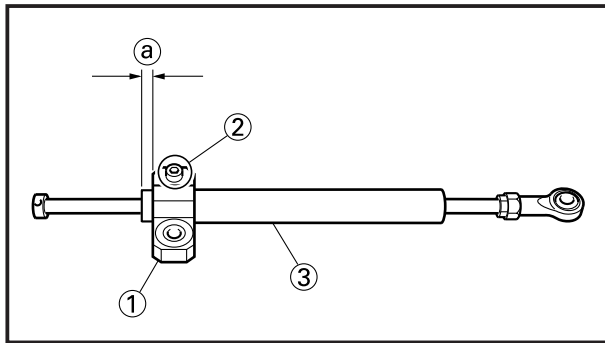

10. Install:
- Steering damper bracket ①
 - Pinch bolt (steering damper bracket) ②

5 Nm (0.5 m•kg, 3.6 ft•lb)

To steering damper ③.

NOTE: _____

When installing the steering damper bracket, provide a distance ① of 9 mm (0.35 in) from its edge.

CAUTION: _____

Tighten the pinch bolt to specified torque. If torqued too much, it may cause the steering damper to malfunction.

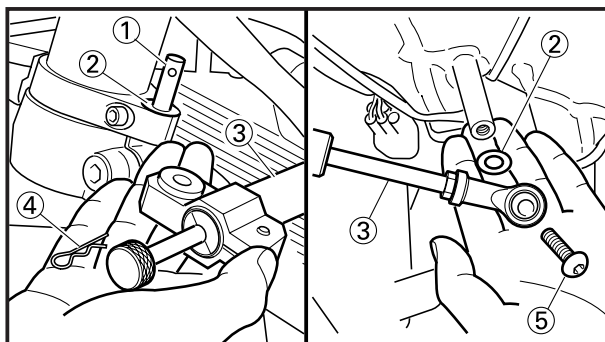

11. Install:
- Pin ①
 - Plain washer ②
 - Steering damper ③
 - Clip ④
 - Bolt (steering damper) ⑤

18 Nm (1.8 m•kg, 13 ft•lb)

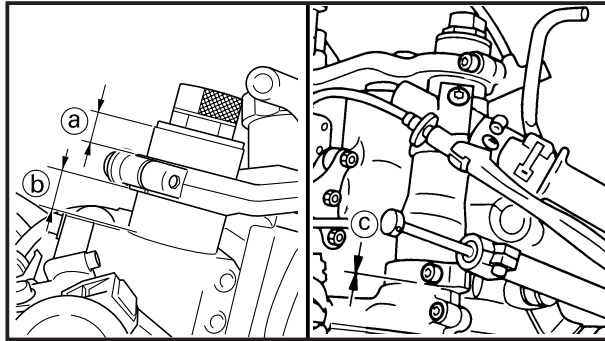

12.Adjust:

- Front fork top end (a)
- Handlebar position (b)
- Steering damper stay position (c) (left side only)



Front fork top end:

18 mm (0.71 in)

Handlebar position:

20 mm (0.79 in)

Steering damper stay position:

Zero mm (Zero in)

Refer to “FRONT FORK TOP END ADJUSTMENT” in the CHAPTER 3.

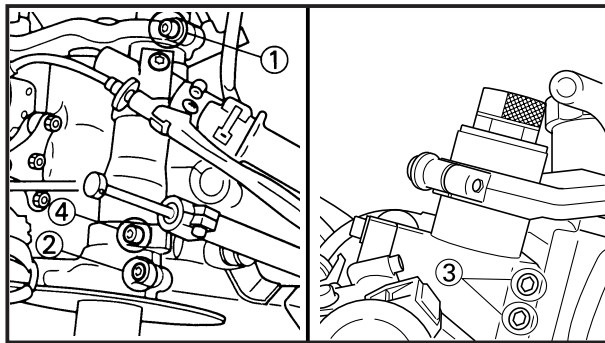

13.Tighten:

- Pinch bolt (handle crown) (1)

15 Nm (1.5 m•kg, 11 ft•lb)

- Pinch bolt (under bracket) (2)

20 Nm (2.0 m•kg, 14 ft•lb)

- Pinch bolt (handle bracket) (3)

8 Nm (0.8 m•kg, 5.8 ft•lb)

- Pinch bolt (steering damper stay) (4) (left side only)

7 Nm (0.7 m•kg, 5.1 ft•lb)

Refer to “FRONT FORK TOP END ADJUSTMENT” in the CHAPTER 3.

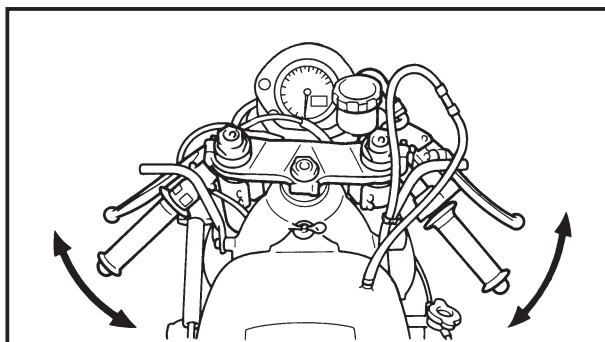

14.Check:

- Steering smooth action
Turn the handlebar to make sure no parts are being contacted with others.
Contact → Repair.



EC570000

SWINGARM

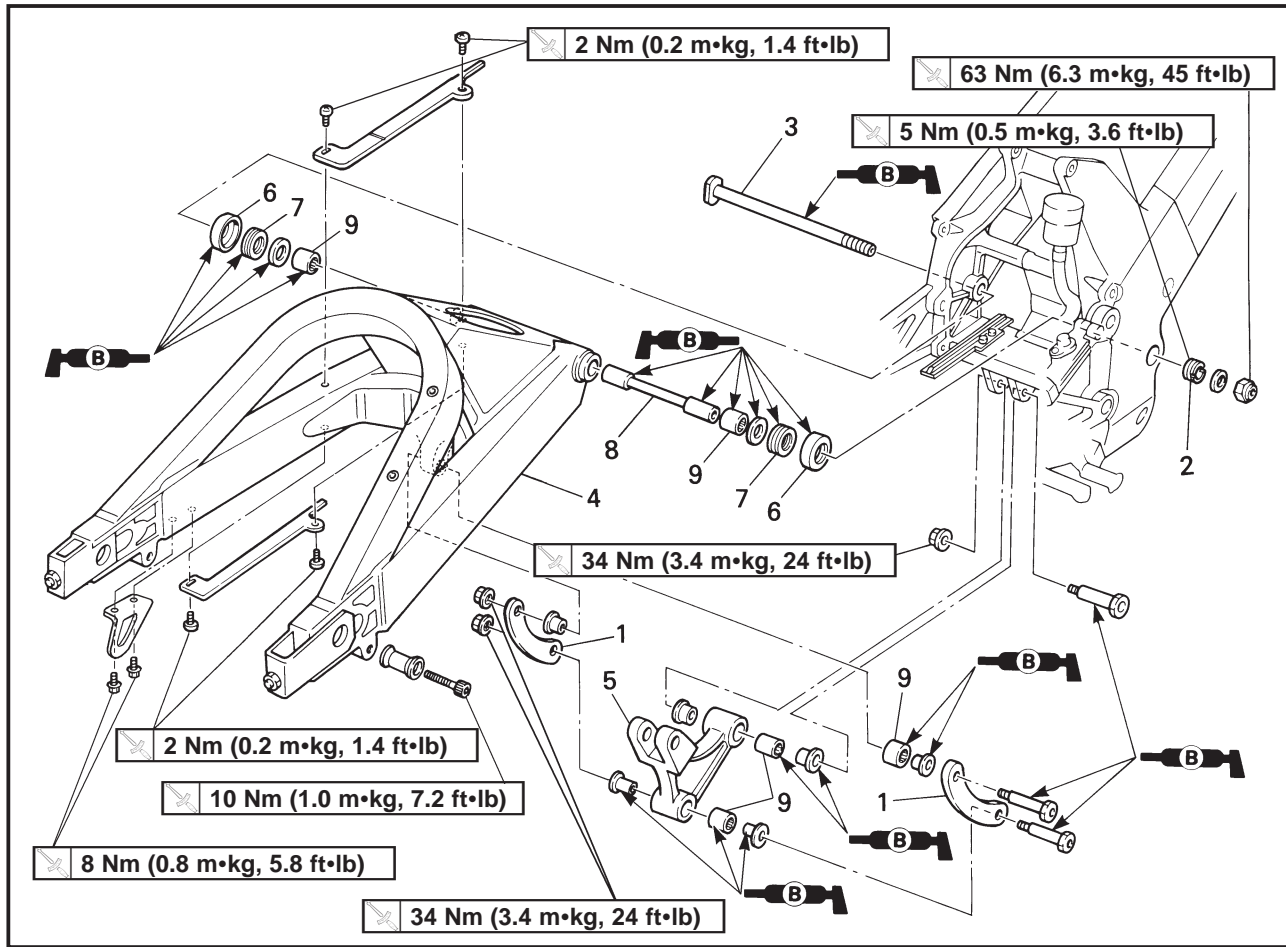

Extend of removal: ① Swingarm removal

② Swingarm disassembly

Extend of removal	Order	Part name	Q'ty	Remarks
Preparation for removal		SWINGARM REMOVAL Hold the machine by placing the suitable stand. Lower cowl Exhaust pipe Brake hose holder Drive chain Rear wheel Rear shock absorber		⚠WARNING Support the machine securely so there is no danger of it falling over. Refer to "COWLING, SEAT AND FUEL TANK" section in the CHAPTER 4. Refer to "EXHAUST PIPE AND SILENCER" section. Refer to "FRONT BRAKE AND REAR BRAKE" section. Refer to "FRONT WHEEL AND REAR WHEEL" section. Refer to "REAR SHOCK ABSORBER" section.
<div style="display: flex; justify-content: space-around;"> <div style="text-align: center;"> ↑ ① ↓ </div> <div style="text-align: center;"> ↑ ② ↓ </div> </div>	1 2 3 4 5 6 7 8 9	Connecting rod Pivot shaft adjust bolt Pivot shaft Swingarm Relay arm Cover Thrust bearing Bush Bearing	2 1 1 1 1 2 2 1 5	Hold the swingarm. Use special tool. Refer to "REMOVAL POINTS". Refer to "REMOVAL POINTS".

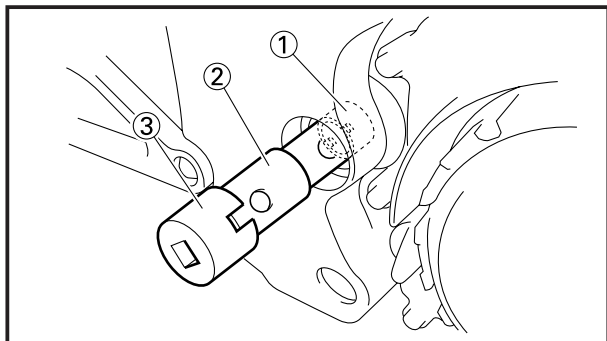

EC573000

REMOVAL POINTS

EC573152

Swingarm

1. Loosen:
 - Pivot shaft adjust bolt ①

NOTE:

Loosen the pivot shaft adjust bolt using the pivot shaft wrench ② and pivot shaft wrench adapter ③.

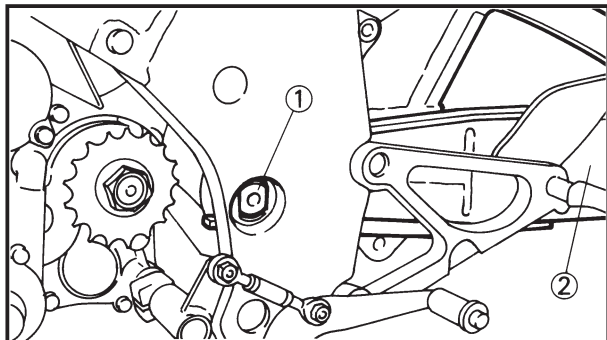

Pivot shaft wrench:

YM-01455/90890-01455

Pivot shaft wrench adapter:

YM-01476/90890-01476

2. Remove:
 - Pivot shaft ①
 - Swingarm ②

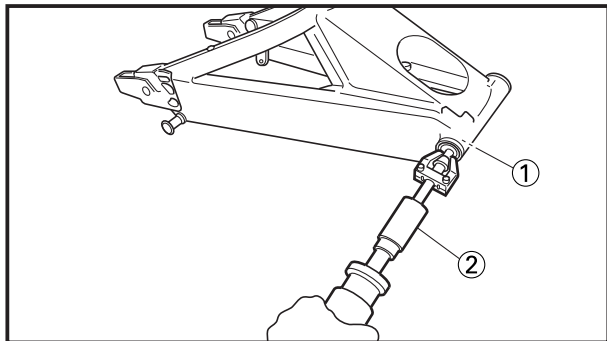

EC573210

Bearing

1. Remove:
 - Bearing ①

Use a general bearing puller ②.

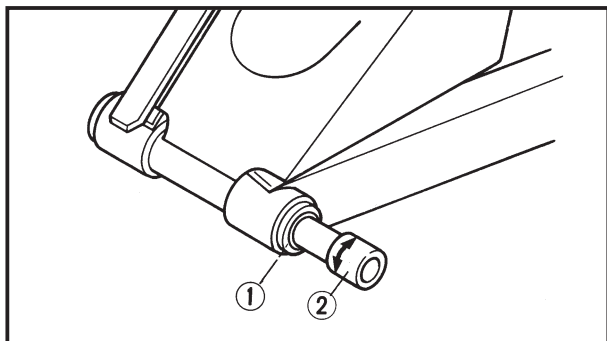

EC574010

INSPECTION

Wash the bearings, bushes, collars, and covers in a solvent.

EC574131

Swingarm

1. Inspect:
 - Bearing ①
 - Bush ②

Free play exists/Unsmooth revolution/Rust
→ Replace bearing and bush as a set.
2. Inspect:
 - Bearing ①
 - Collar ②

Free play exists/Unsmooth revolution/Rust
→ Replace bearing and collar as a set.

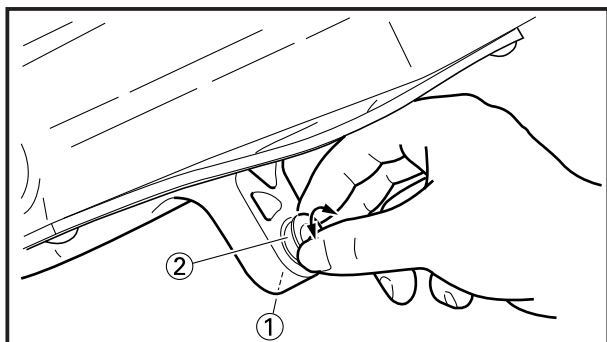

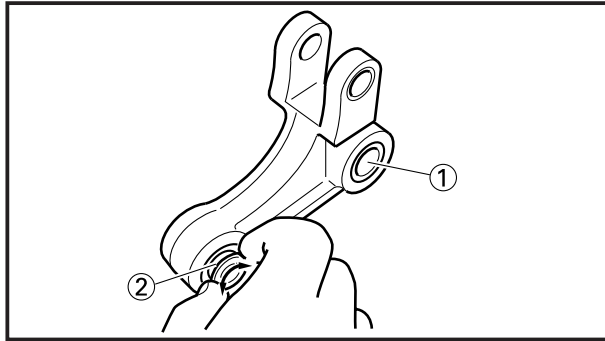

EC574220

Relay arm

1. Inspect:

- Bearing ①
- Collar ②

Free play exists/Unsmooth revolution/Rust
→ Replace bearing and collar as a set.

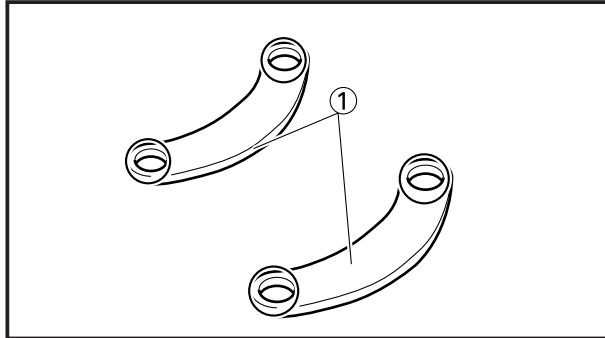

EC574320

Connecting rod

1. Inspect:

- Connecting rod ①

Wear/Damage → Replace.

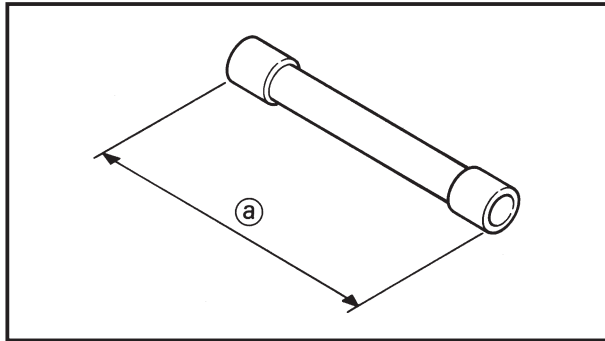

EC574520

Swingarm side clearance

1. Measure:

- Bush length ①

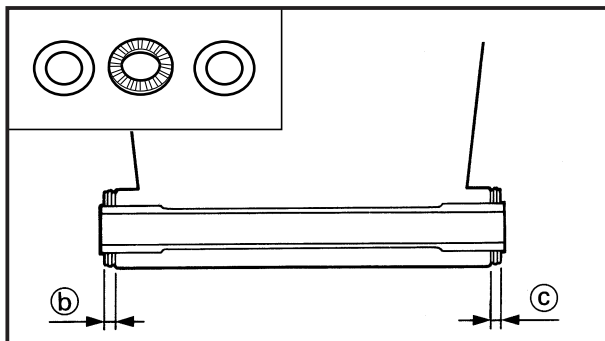

2. Measure:

- Thrust bearing (right) thickness ②
- Thrust bearing (left) thickness ③

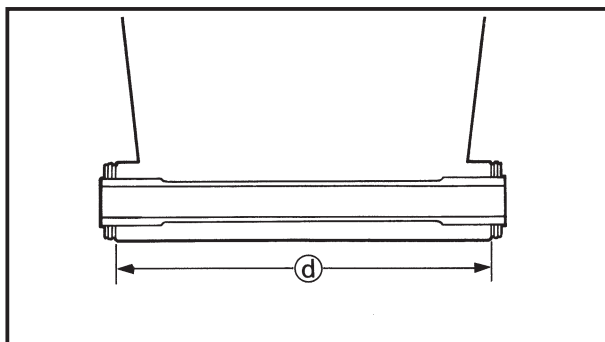

3. Measure:

- Swingarm head pipe length ④

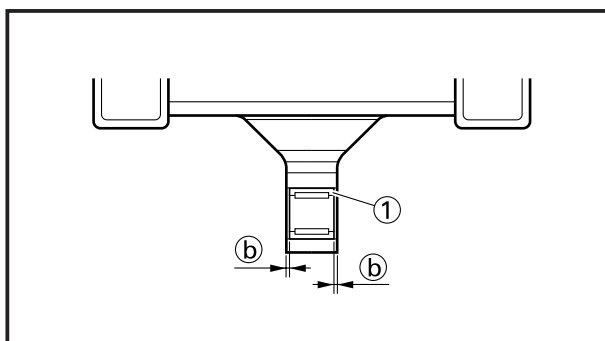
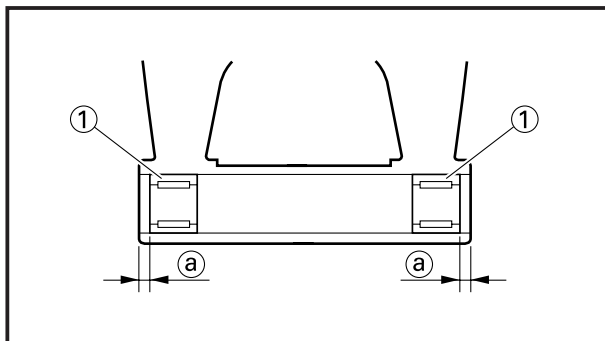
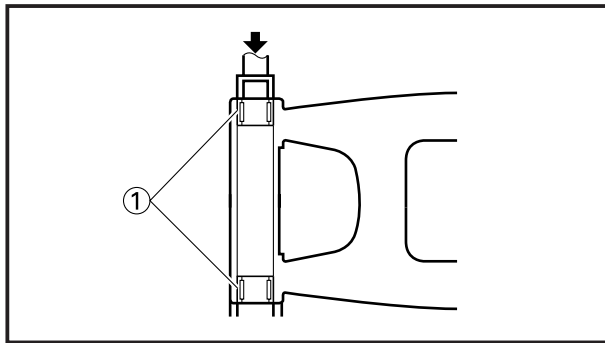
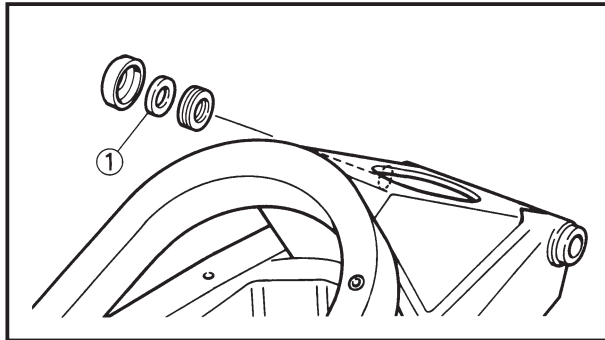
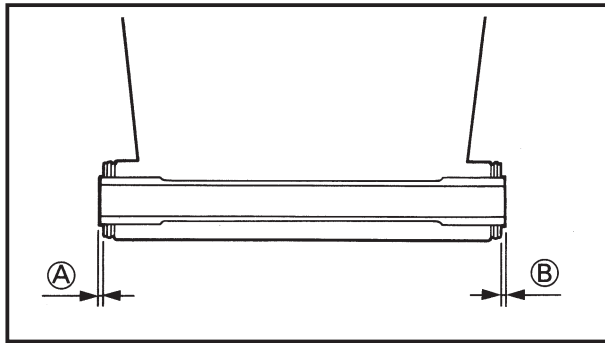

4. Calculate:

- Swingarm side clearance “A + B”
Out of specification → Adjust side clearance using shim.
By using formula given below.

$$“A + B” = a - (b + c + d)$$



Side clearance “A + B”:
0.05~0.35 mm (0.002~0.014 in)

If the side clearance is out of specification, adjust it to specification by installing the adjust shim ① at position, A and B.

NOTE:

- The adjust shim is available only in the 0.3 mm (0.012 in)-thick type.
- When only one shim is required, install it on the left side, and when two shims are necessary, install them on both right and left sides.

EC575000

ASSEMBLY AND INSTALLATION

EC575300

Bearing

1. Install:
 - Bearing ①
To swingarm.

NOTE:

- Apply the lithium soap base grease on the bearing when installing.
- Install the bearing by pressing it on the side having the manufacture’s marks or numbers.



Installed depth of bearings:
For head pipe ②:
0.5~1.0 mm (0.02~0.04 in)
For connecting rod bracket ③:
0.5 mm (0.02 in)

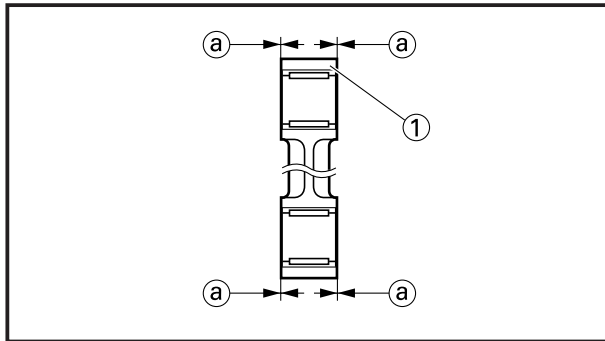

2. Install:
- Bearing ①
To relay arm.

NOTE: _____

- Apply the lithium soap base grease on the bearing when installing.
- Install the bearing by pressing it on the side having the manufacture's marks or numbers.



Installed depth of bearings ②:
Zero mm (Zero in)

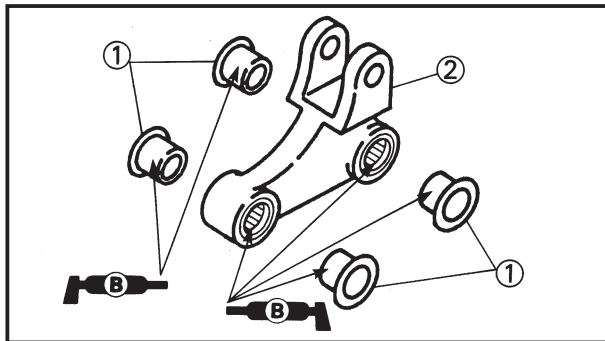

EC575163
Swingarm

1. Install:
- Collar ①
To relay arm ②.

NOTE: _____

Apply the lithium soap base grease on the collars and bearings.

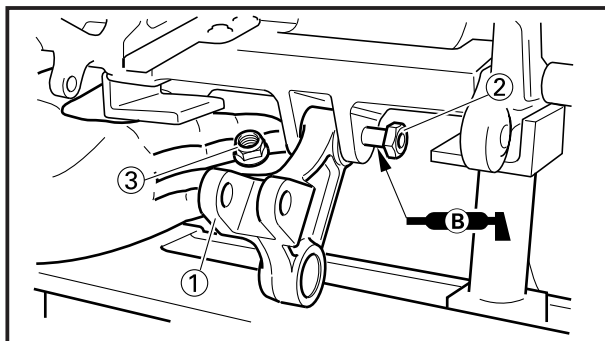

2. Install:
- Relay arm ①
 - Bolt (relay arm) ②
 - Nut (relay arm) ③

34 Nm (3.4 m•kg, 24 ft•lb)

NOTE: _____

Apply the lithium soap base grease on the bolt.

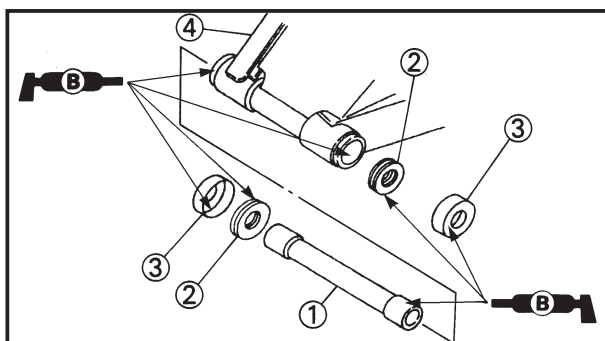

3. Install:
- Bush ①
 - Thrust bearing ②
 - Cover ③
To swingarm ④.

NOTE: _____

Apply the lithium soap base grease on the bush, bearings and cover lips.

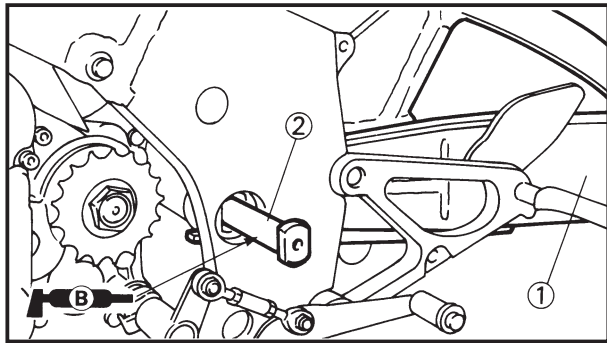

4. Install:
- Swingarm ①
 - Pivot shaft ②

NOTE:

- Apply the lithium soap base grease on the pivot shaft.
- Insert the pivot shaft from left side.

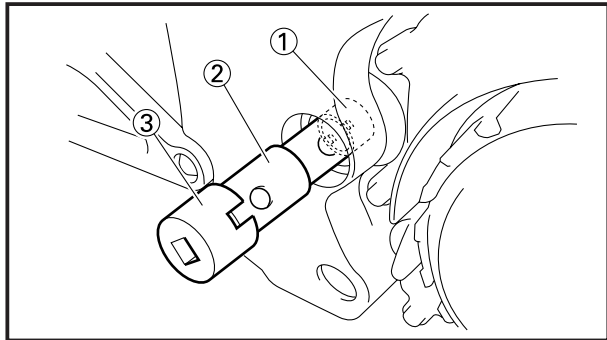

5. Tighten:

- Pivot adjust bolt ①

5 Nm (0.5 m•kg, 3.6 ft•lb)

NOTE:

Use the pivot shaft wrench ② and pivot shaft wrench adapter ③ to tighten the pivot adjust bolt.

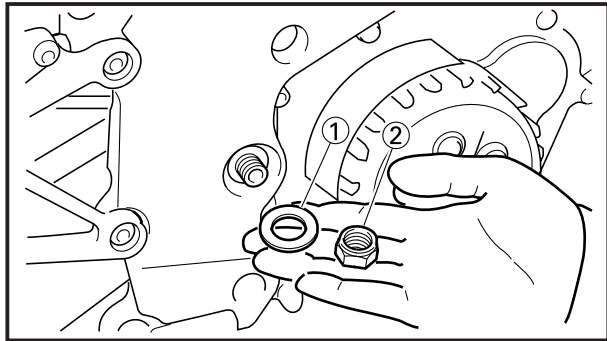

6. Install:

- Plain washer ①
- Nut (pivot shaft) ②

63 Nm (6.3 m•kg, 45 ft•lb)

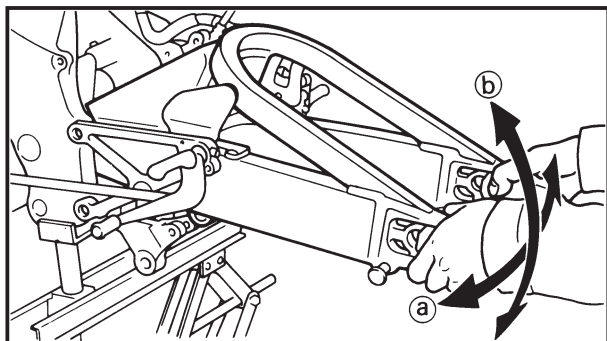

7. Check:

- Swingarm side play (a)
Free play exists → Check side clearance.
- Swingarm up and down movement (b)
Unsmooth movement/Binding/Rough spots
→ Grease or replace bearings, bushes and collars.

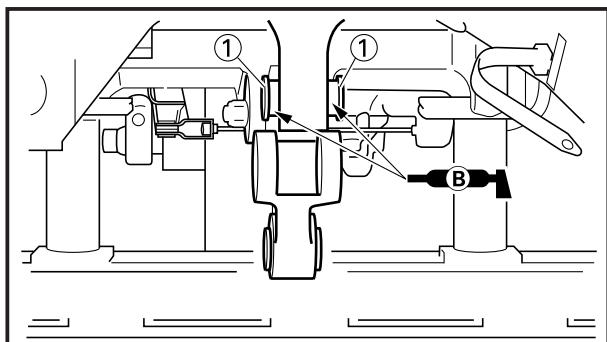

8. Install:

- Collar (swingarm) ①

NOTE:

Apply the lithium soap base grease on the collars and bearings.

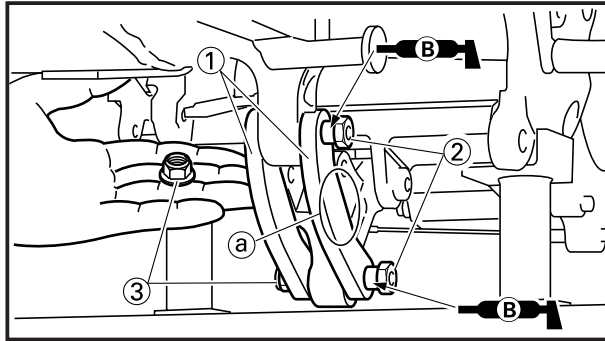

9. Install:

- Connecting rod ①
- Bolt (connecting rod) ②
- Nut (connecting rod) ③

34 Nm (3.4 m•kg, 24 ft•lb)

NOTE:

- Install the connecting rods with the mark ① outward of the chassis.
- Apply the lithium soap base grease on the bolts.



EC580000

REAR SHOCK ABSORBER

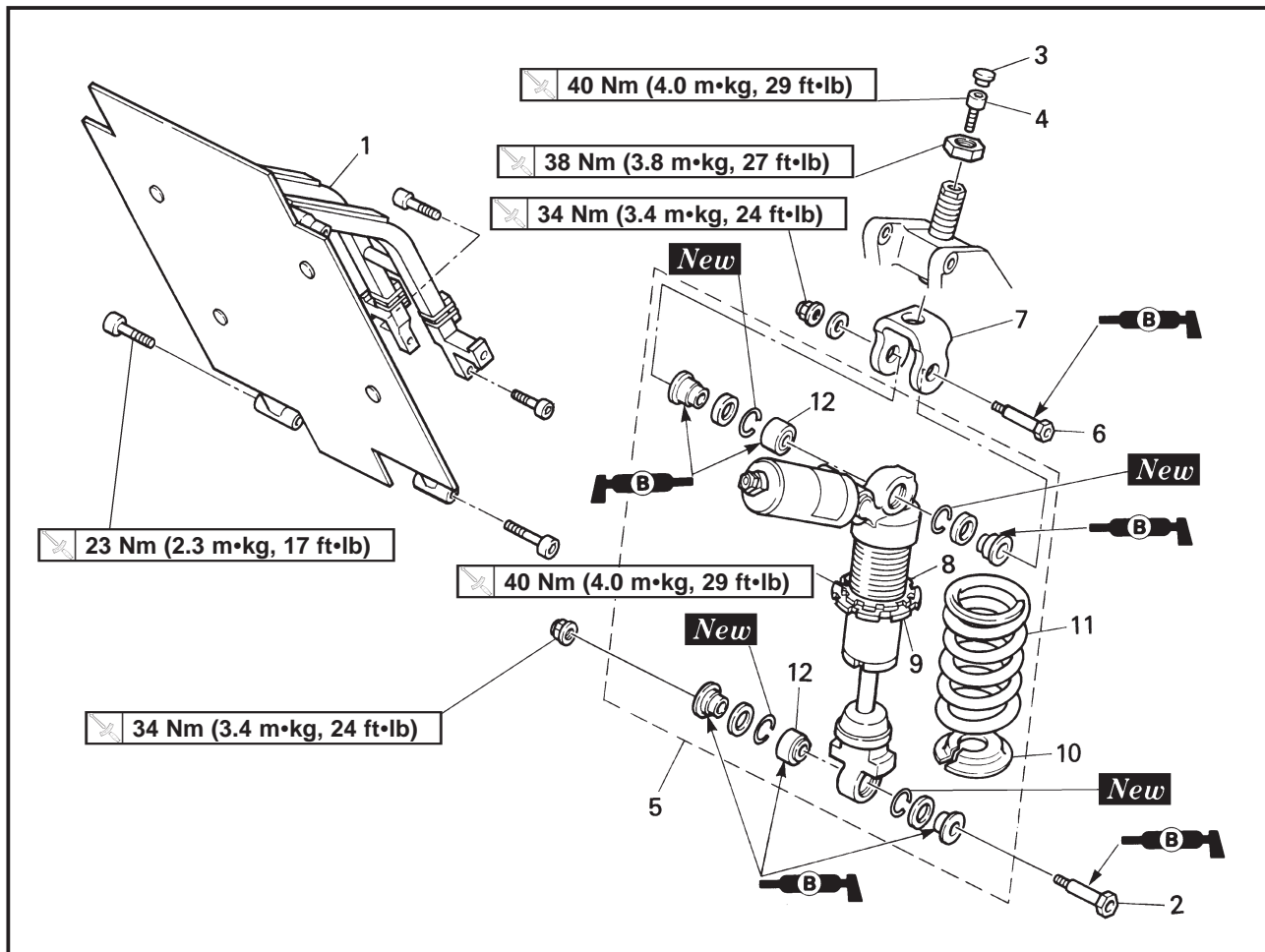

Extend of removal: ① Rear shock absorber removal

② Rear shock absorber disassembly

Extend of removal	Order	Part name	Q'ty	Remarks
Preparation for removal		REAR SHOCK ABSORBER REMOVAL Hold the machine by placing the suitable stand. Lower cowl, seat and fuel tank Exhaust pipe		⚠WARNING Support the machine securely so there is no danger of it falling over. Refer to "COWLING, SEAT AND FUEL TANK" section in the CHAPTER 4. Refer to "EXHAUST PIPE AND SILENCER" section in the CHAPTER 4.
	①	1 Rear frame 2 Bolt (rear shock absorber – relay arm) 3 Cap 4 Bolt (Upper bracket) 5 Rear shock absorber 6 Bolt (rear shock absorber – upper bracket) 7 Upper bracket 8 Locknut 9 Adjuster 10 Spring guide 11 Spring (rear shock absorber) 12 Bearing	1 1 1 1 1 1 1 1 1 1 1 2	Hold the swingarm. Loosen. Loosen. Refer to "REMOVAL POINTS".



EC586000

HANDLING NOTE**⚠WARNING**

This shock absorber is provided with a separate type tank filled with high-pressure nitrogen gas. To prevent the danger of explosion, read and understand the following information before handling the shock absorber.

The manufacturer can not be held responsible for property damage or personal injury that may result from improper handling.

1. Never tamper or attempt to disassemble the cylinder or the tank.
2. Never throw the shock absorber into an open flame or other high heat. The shock absorber may explode as a result of nitrogen gas expansion and/or damage to the hose.
3. Be careful not to damage any part of the gas tank. A damaged gas tank will impair the damping performance or cause a malfunction.
4. Take care not to scratch the contact surface of the piston rod with the cylinder; or oil could leak out.
5. Never attempt to remove the plug at the bottom of the nitrogen gas tank. It is very dangerous to remove the plug.
6. When scrapping the shock absorber, follow the instructions on disposal.

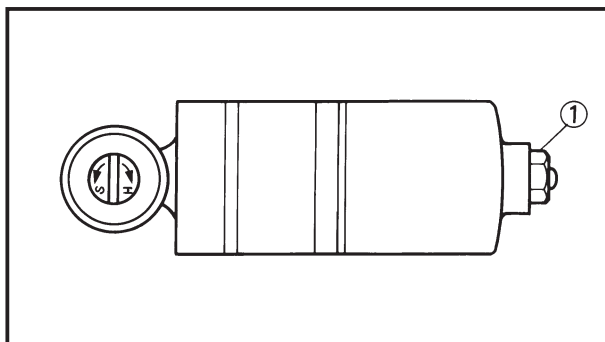

EC587030

NOTES ON DISPOSAL (YAMAHA DEALERS ONLY)

Before disposing of the shock absorber, be sure to extract the nitrogen gas. To do so, loosen the nut ① of the tank. At this time, wear eye protection to prevent eye damage from escaping gas and/or metal chips.

⚠WARNING

To dispose of a damaged or worn-out shock absorber, take the unit to your Yamaha dealer for this disposal procedure.

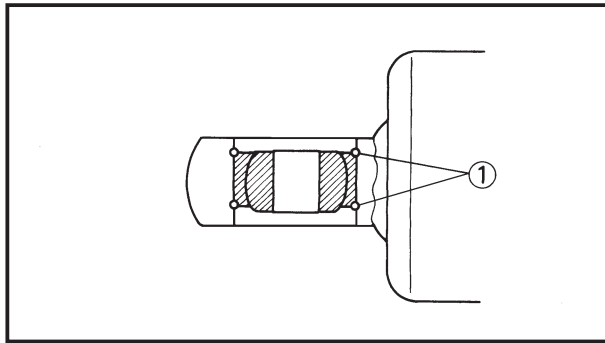

EC583000

REMOVAL POINTS

EC583310

Bearing

1. Remove:
 - Stopper ring ①

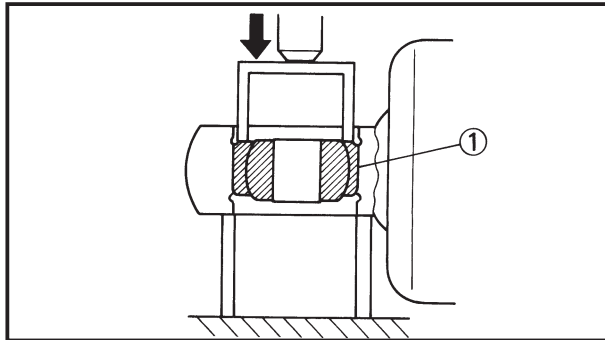

2. Remove:
 - Bearing ①

NOTE:

Remove the bearing by pressing its outer race.

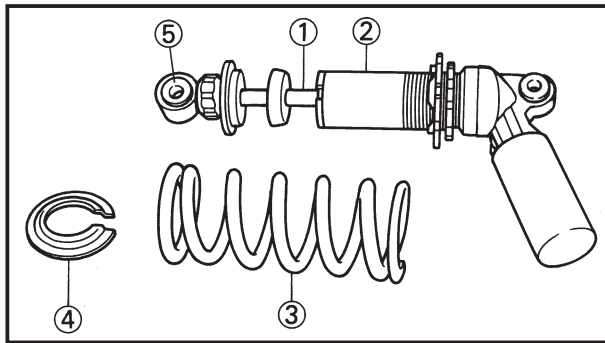

EC584000

INSPECTION

EC584110

Rear shock absorber

1. Inspect:
 - Damper rod ①
Bends/Damage → Replace absorber assembly.
 - Shock absorber ②
Oil leaks → Replace absorber assembly.
Gas leaks → Replace absorber assembly.
 - Spring ③
Damage → Replace spring.
Fatigue → Replace spring.
Move spring up and down.
 - Spring guide ④
Wear/Damage → Replace spring guide.
 - Bearing ⑤
Free play exists/Unsmooth revolution/Rust → Replace.

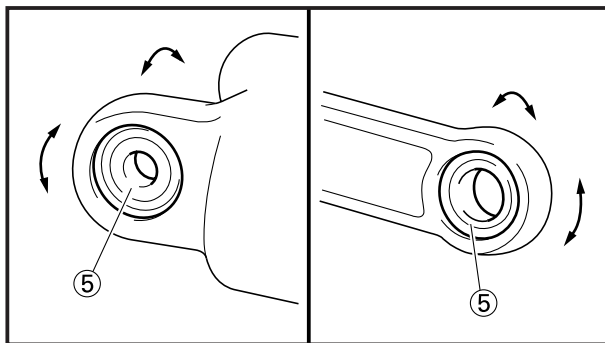

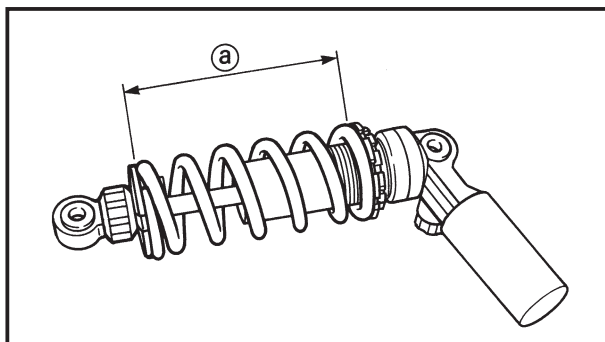
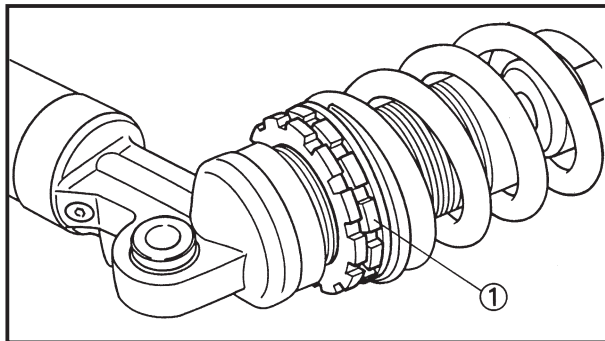
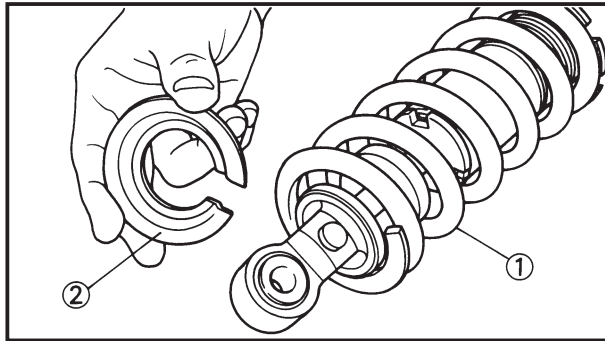
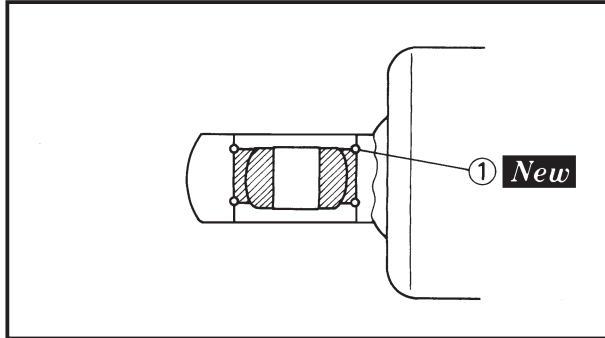
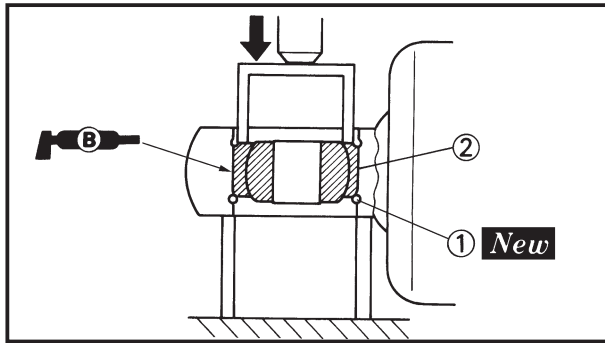

EC585000

ASSEMBLY AND INSTALLATION

EC585310

Bearing

1. Install:
 - Stopper ring ① **New**
 - Bearing ②

NOTE:

- Apply the lithium soap base grease on the bearing when installing.
- Install the bearing parallel until it contacts the stopper ring by pressing its outer race.

2. Install:
 - Stopper ring ① **New**

EC585130

Spring (rear shock absorber)

1. Install:
 - Spring ①
 - Spring guide ②

2. Tighten:
 - Adjuster ①

3. Adjust:
 - Spring length (installed) ①

Spring length (installed) ①:	
Standard length	Extent of adjustment
138mm (5.43 in)	130~150 mm (5.12~5.91 in)



NOTE:

The length of the spring (installed) changes 1.5mm (0.06 in) per turn of the adjuster.

CAUTION:

Never attempt to turn the adjuster beyond the maximum or minimum setting.

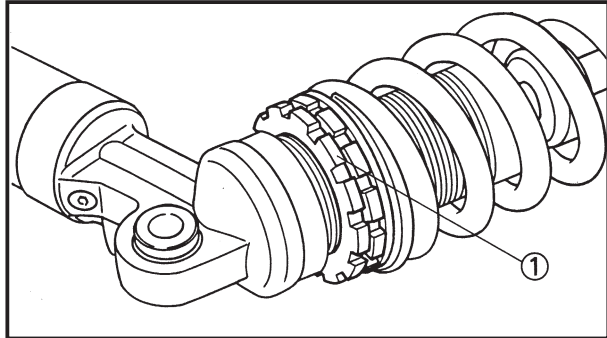

4. Tighten:

- Locknut ①

40 Nm (4.0 m•kg, 29 ft•lb)

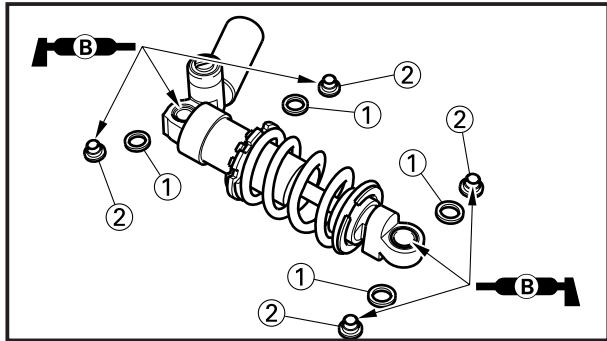

EC585262

Rear shock absorber

1. Install:

- Dust seal ①
- Collar ②

NOTE:

Apply the lithium soap base grease on the bearings and collars.

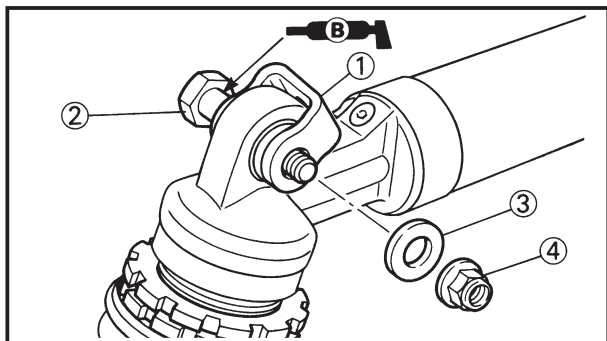

2. Install:

- Upper bracket ①
- Bolt (rear shock absorber–upper bracket) ②
- Plain washer (rear shock absorber–upper bracket) ③
- Nut (rear shock absorber–upper bracket) ④

34 Nm (3.4 m•kg, 24 ft•lb)

NOTE:

Apply the lithium soap base grease on the bolt.

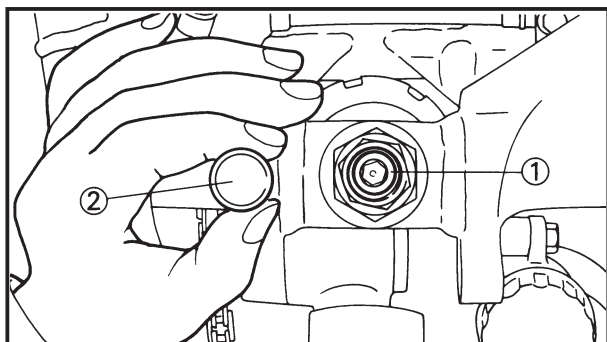

3. Install:

- Rear shock absorber

4. Install:

- Bolt (upper bracket) ①

40 Nm (4.0 m•kg, 29 ft•lb)

- Cap ②

REAR SHOCK ABSORBER

CHAS

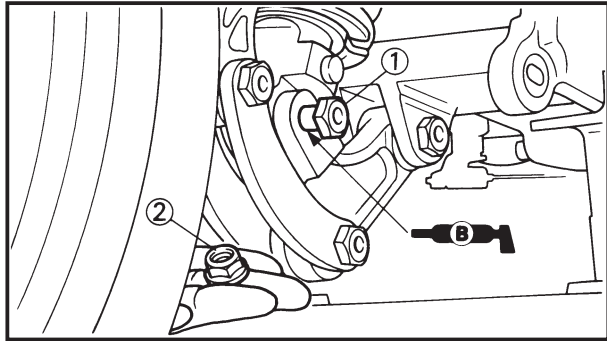

5. Install:

- Bolt (rear shock absorber–relay arm) ①
- Nut (rear shock absorber–relay arm) ②

34 Nm (3.4 m•kg, 24 ft•lb)

NOTE:

Apply the lithium soap base grease on the bolt.

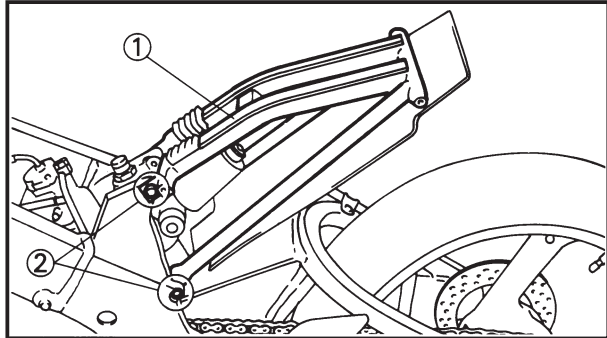

6. Install:

- Rear frame ①
- Bolt (rear frame) ②

23 Nm (2.3 m•kg, 17 ft•lb)

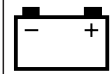

EC600000

ELECTRICAL

EC610000

ELECTRICAL COMPONENTS AND WIRING DIAGRAM

EC611000

ELECTRICAL COMPONENTS

- | | |
|------------------------|------------------|
| ① CDI unit | ⑥ Ignition coil |
| ② Voltage regulator | ⑦ Spark pulg |
| ③ Condenser | ⑧ Solenoid valve |
| ④ Tachometer assembly | ⑨ CDI magneto |
| ⑤ "ENGINE STOP" button | ⑩ Thermo unit |

COLOR CODE

- | | |
|-------------------|---------------------------|
| BBlack | B/LBlack/Blue |
| BrBrown | B/WBlack/White |
| GGreen | G/WGreen/White |
| GyGray | O/BOrange/Black |
| PPink | W/BWhite/Black |
| RRed | W/GWhite/Green |
| WWhite | |

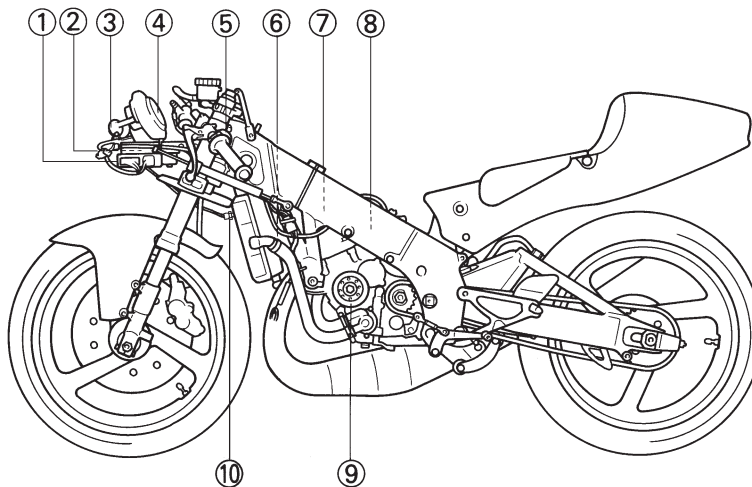

EC612000

WIRING DIAGRAM

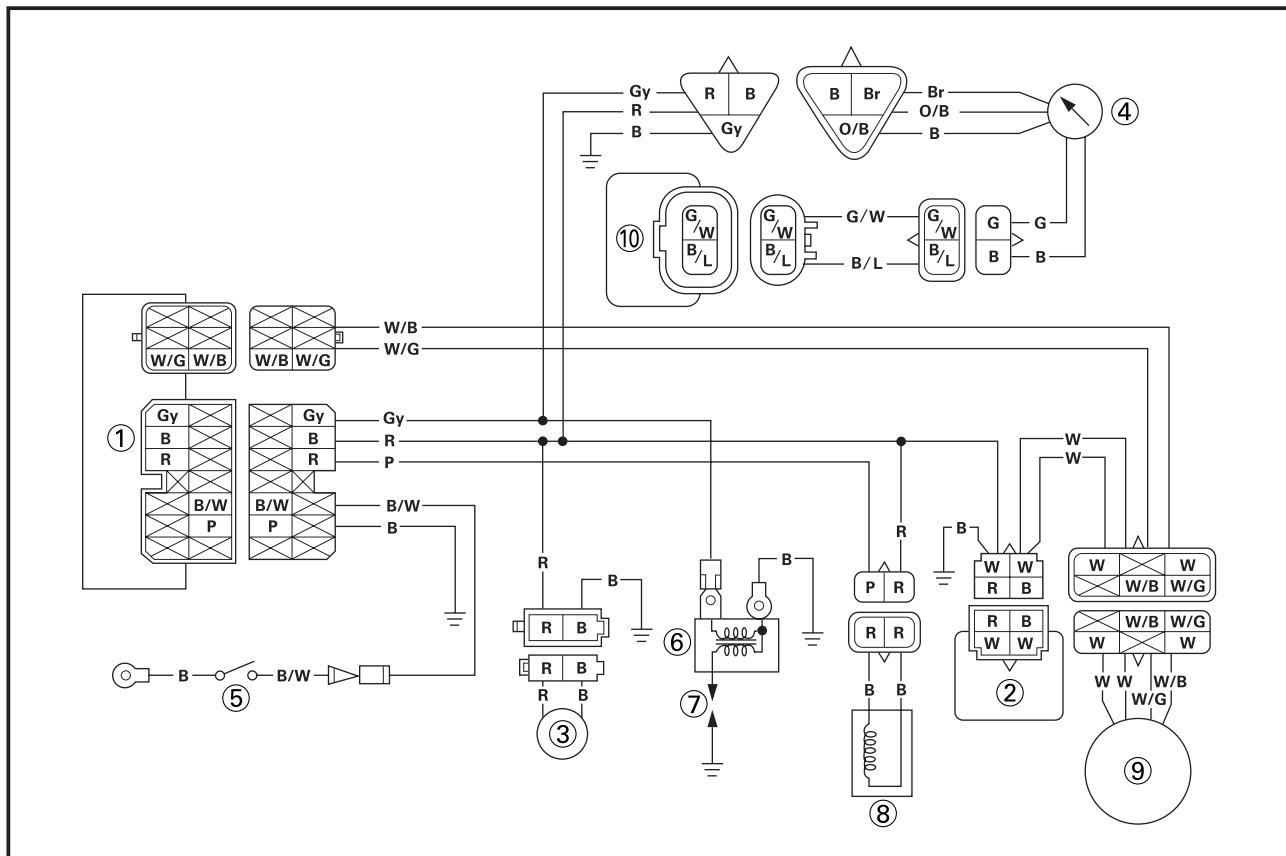

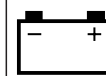

EC620000

IGNITION SYSTEM

EC621022

INSPECTION STEPS

Use the following steps for checking the possibility of the malfunctioning engine being attributable to ignition system failure and for checking the spark plug which will not spark.

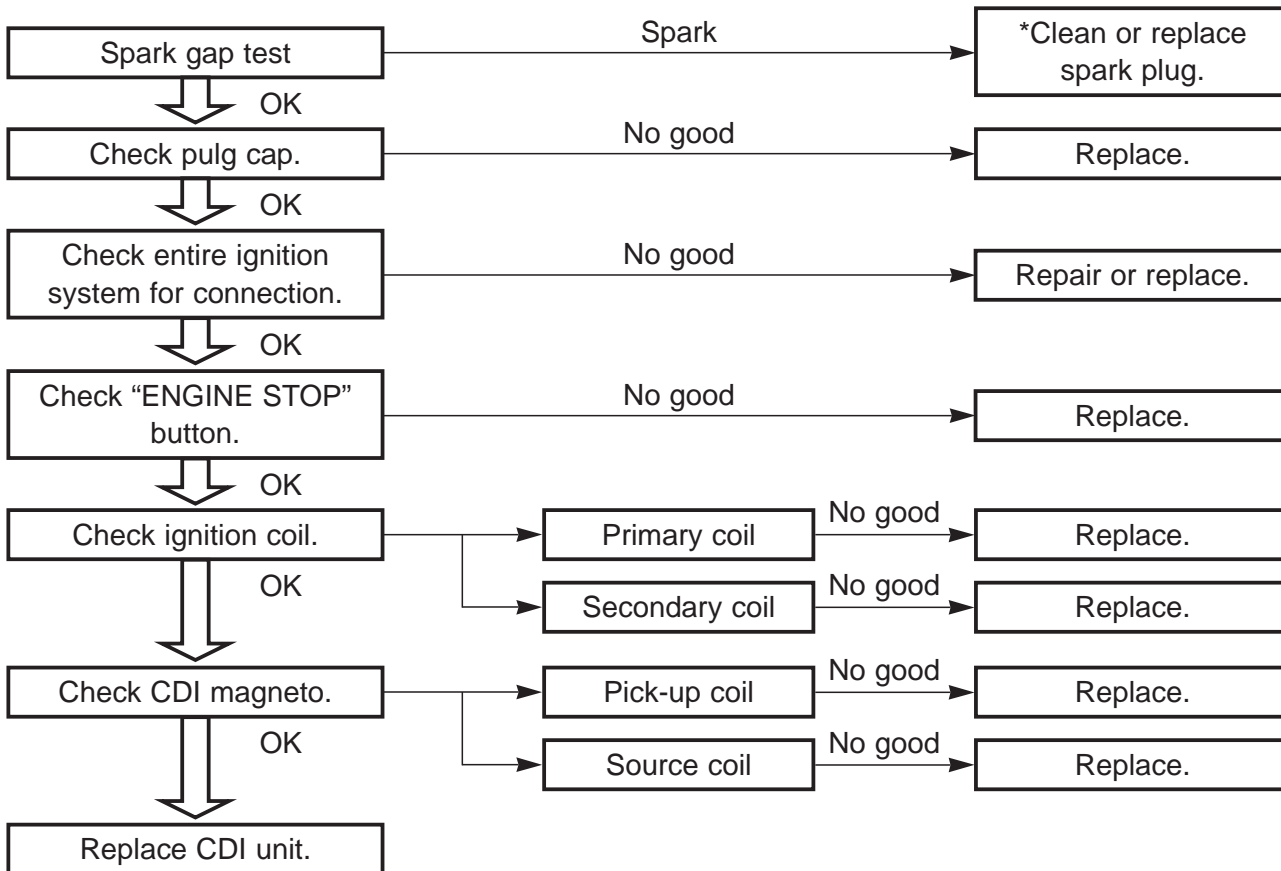

*marked : Only when the ignition checker is used.

NOTE:

- Remove the following parts before inspection.
 - 1) Cowling
 - 2) Fuel tank
- Use the following special tools in this inspection.

	<p>Dynamic spark tester: YM-34487</p> <p>Ignition checker: 90890-06754</p>
---	--

	<p>Pocket tester: YU-03112/90890-03112</p>
---	---

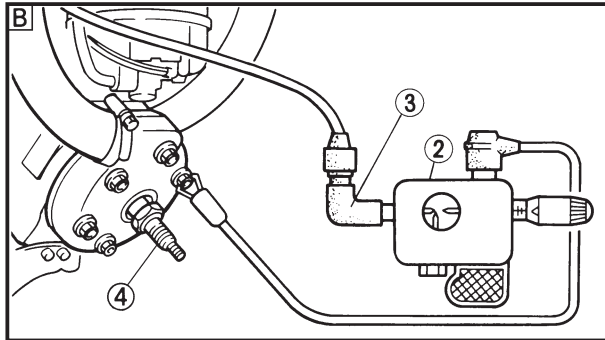
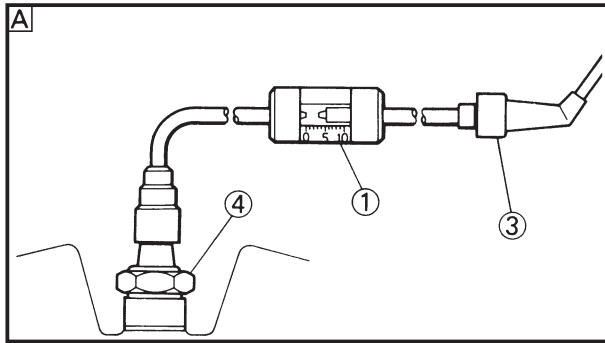
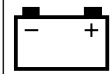

EC622010

SPARK GAP TEST

1. Disconnect the spark plug cap from spark plug.
2. Connect the dynamic spark tester ① (ignition checker ②) as shown.
 - Spark plug cap ③
 - Spark plug ④
- Ⓐ For USA and CDN
- Ⓑ Except for USA and CDN
3. Start the engine and increase the spark gap until misfire occurs. (for USA and CDN)
4. Rotate the rear wheel with gear in 3rd and check the spark gap. (except for USA and CDN)

Minimum spark gap:
5 mm(0.2 in)

EC623001

SPARK PLUG CAP INSPECTION

1. Remove:
 - Spark plug cap

CAUTION: _____

Do not pull the spark plug lead out of the spark plug cap. Turn the spark plug cap counterclockwise to remove it and clockwise to install it.

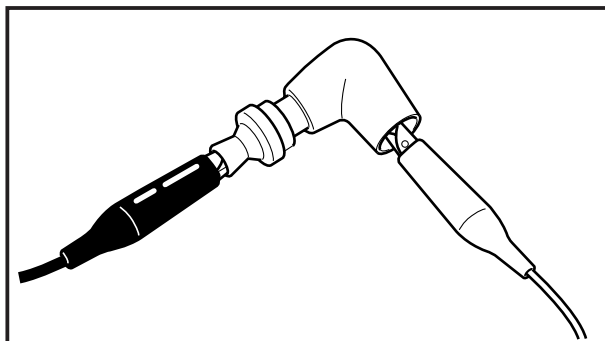

2. Check:
 - Spark plug cap resistance
 Out of specification → Replace.

	Spark plug cap resistance	Tester selector position
	4~6 kΩ at 20°C (68°F)	kΩ × 1

EC624000

COUPLERS AND LEADS CONNECTION INSPECTION

1. Check:
 - Couplers and leads connection
 Rust/ Dust/ Looseness/Short-circuit → Repair or replace.

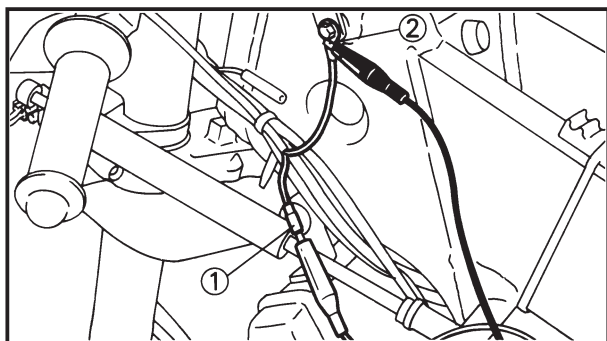

EC625002

“ENGINE STOP” BUTTON INSPECTION

- Inspect:
 - “ENGINE STOP” button conduct

Tester (+) lead → Black/White lead ①
 Tester (-) lead → Black lead ②

		B/W ①	B ②	Tester selector position
	PUSH IN FREE	○	○	Ω × 1

Not continuous while being pushed → Replace.
 Continuous while being freed → Replace.

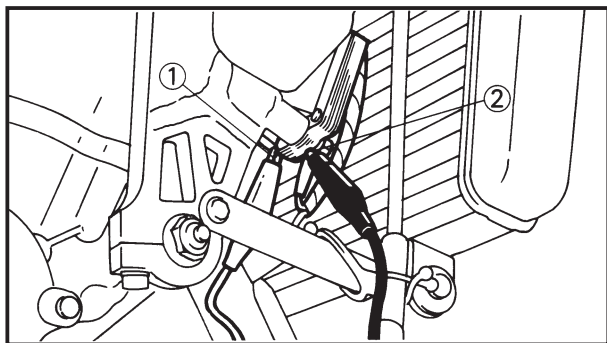

EC626002

IGNITION COIL INSPECTION

- Inspect:
 - Primary coil resistance
 Out of specification → Replace.

Tester (+) lead → Gray lead ①
 Tester (-) lead → Black lead ②

	Primary coil resistance	Tester selector position
	0.14~0.18 Ω at 20°C (68°F)	Ω × 1

- Inspect:
 - Secondary coil resistance
 Out of specification → Replace.

Tester (+) lead → Spark plug lead ①
 Tester (-) lead → Black lead ②

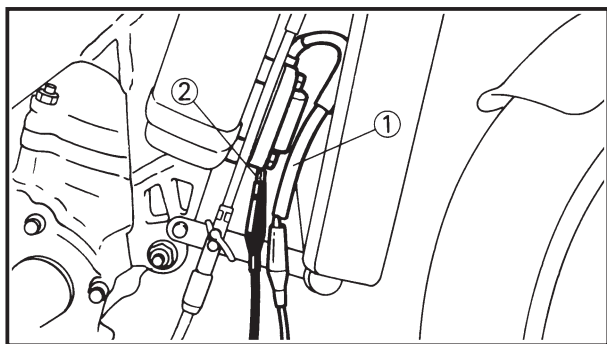

	Secondary coil resistance	Tester selector position
	5.0~7.4 kΩ at 20°C (68°F)	kΩ × 1

NOTE: _____
 When inspecting the secondary coil resistance, remove the spark plug cap.

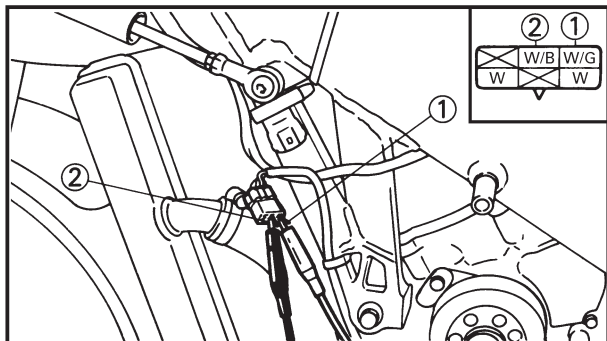
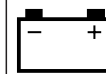

EC627001

CDI MAGNETO INSPECTION

1. Inspect:

- Pick-up coil resistance
Out of specification → Replace.

Tester (+) lead → White/Green lead ①
Tester (-) lead → White/Black lead ②

	Pick-up coil resistance	Tester selector position
	94~140 Ω at 20°C (68°F)	Ω × 100

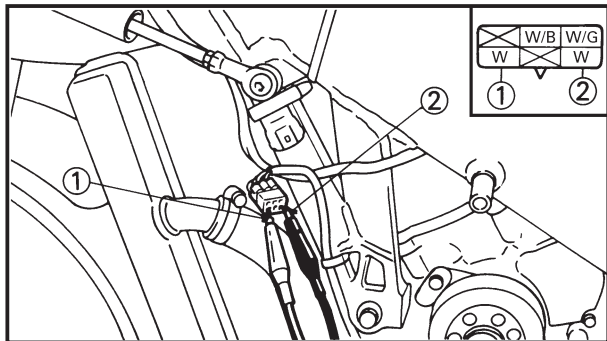

2. Inspect:

- Source coil resistance
Out of specification → Replace.

Tester (+) lead → White lead ①
Tester (-) lead → White lead ②

	Source coil resistance	Tester selector position
	1.3~1.9 Ω at 20°C (68°F)	Ω × 1

EC628000

CDI UNIT INSPECTION

Check all electrical components. If no fault is found, replace the CDI unit. Then check the electrical components again.

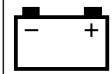

EC650001

SOLENOID VALVE SYSTEM

EC651012

INSPECTION STEPS

If the solenoid valve will not operate, use the following inspection steps.

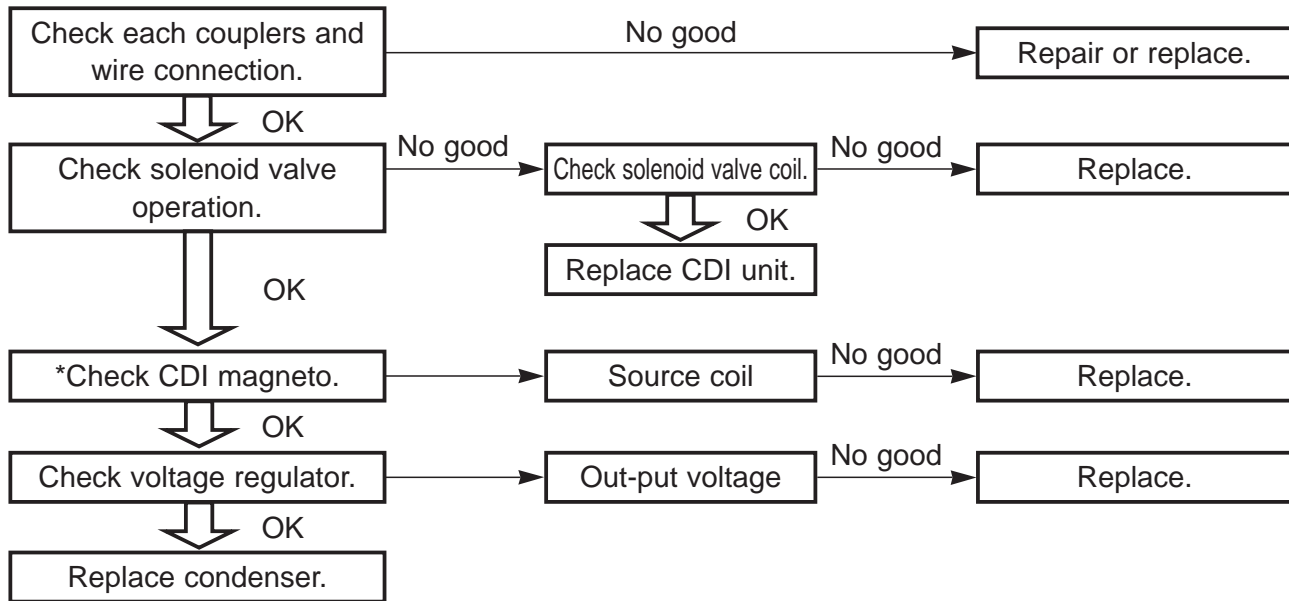

* marked: Refer to "IGNITION SYSTEM" section.

NOTE:

- Remove the following parts before inspection.
 - 1) Cowling
 - 2) Fuel tank
- Use 12V battery in this inspection.
- Use the following special tools in this inspection.



Pocket tester:
YU-03112/90890-03112

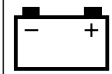

EC624000

COUPLERS AND LEADS CONNECTION INSPECTION

1. Check:
 - Couplers and leads connection
Rust/ Dust/ Looseness/Short-circuit → Repair or replace.

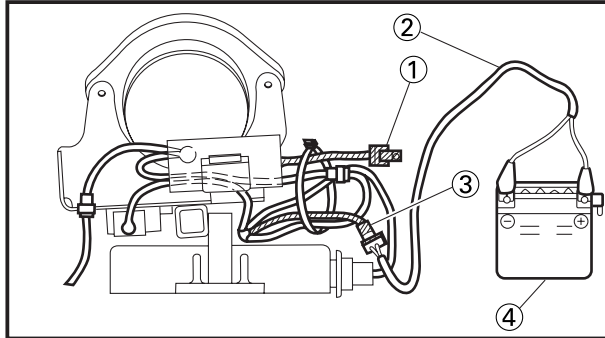

EC652030

SOLENOID VALVE OPERATION

1. Check:
 - Solenoid valve operation

Checking steps:

- Disconnect the condenser lead ①.
- Connect the checking lead ② between the wireharness ③ and battery (12V) ④.
- Check the solenoid valve ⑤ operation.
If a click can be heard the solenoid valve is working properly.
No click → •Check the coupler and lead connection.
•Check the solenoid valve resistance.

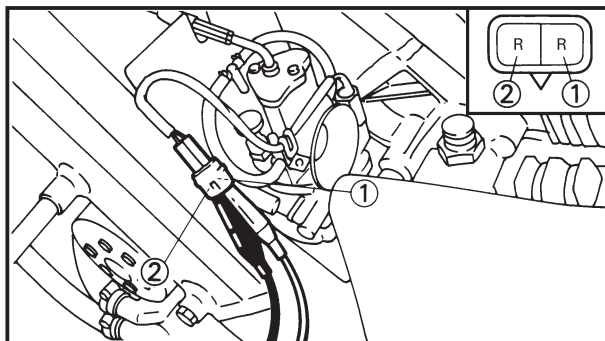
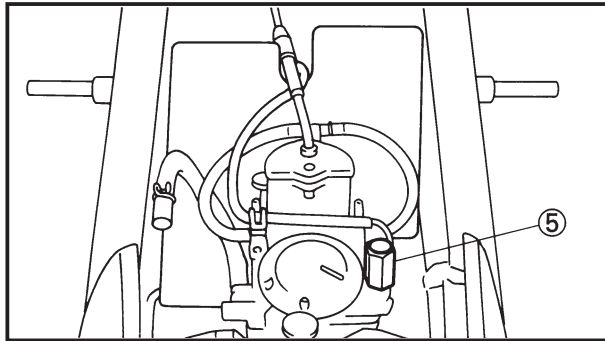

EC653002

SOLENOID VALVE COIL INSPECTION

1. Inspect:
 - Solenoid valve coil resistance
Out of specification → Replace.

Tester (+) lead → Red lead ①
Tester (-) lead → Red lead ②

	Solenoid resistance	Tester selector position
	22.8~27.8 Ω at 20°C (68°F)	Ω × 10

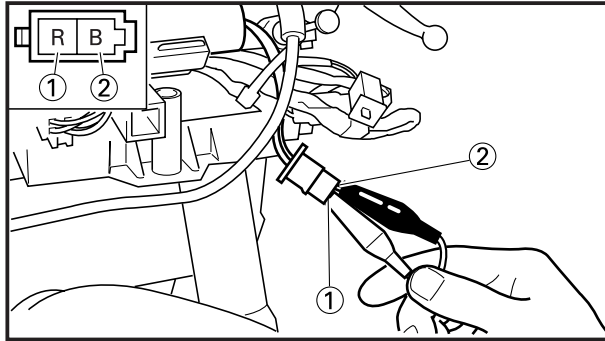
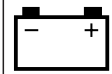

EC635002

VOLTAGE REGULATOR INSPECTION

1. Disconnect the condenser lead.
2. Start the engine.
3. Inspect:
 - Out-put voltage
Out of specification → Replace voltage regulator.

Tester (+) lead → Red lead ①

Tester (-) lead → Black lead ②

	Out-put voltage	Tester selector position
	14.2~15.2 V at 5,000 r/min	DCV-20

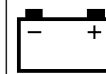

EC6A0000

THERMO UNIT SYSTEM

EC6A1000

INSPECTION STEPS

If the water temperature gauge (thermo unit) will not operate, use the following inspection steps.

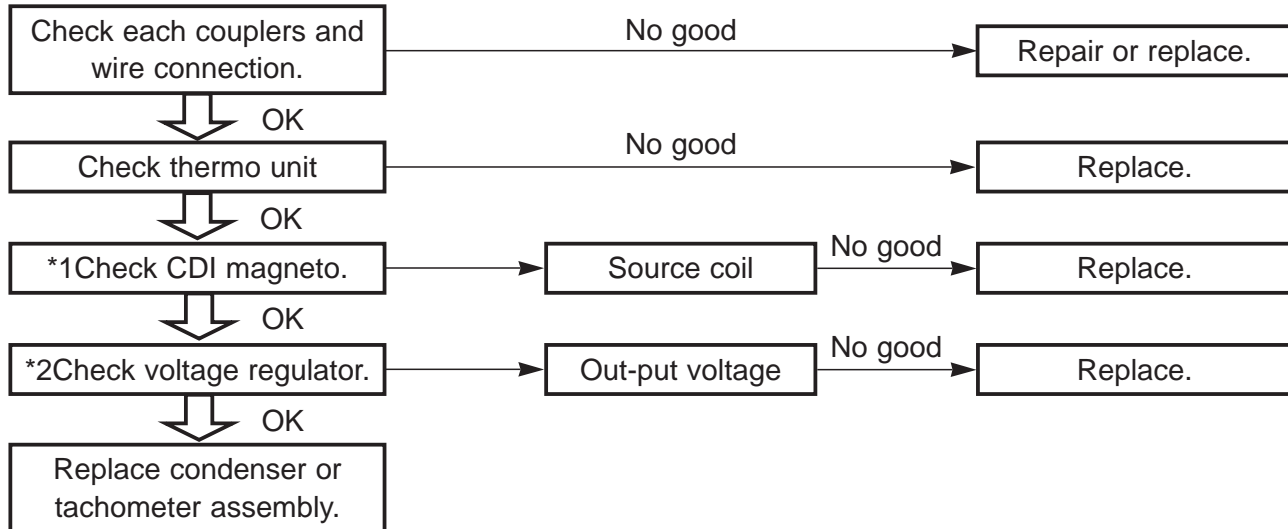

***1 marked: Refer to “IGNITION SYSTEM” section.**

***2 marked: Refer to “SOLENOID VALVE SYSTEM” section.**

NOTE:

- Remove the following parts before inspection.
- 1) Cowling
- Use the following special tools in this inspection.



Pocket tester:
YU-03112/90890-03112

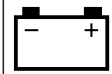

EC624000

COUPLERS AND LEADS CONNECTION INSPECTION

1. Check:
 - Couplers and leads connection
Rust/ Dust/ Looseness/Short-circuit → Repair or replace.

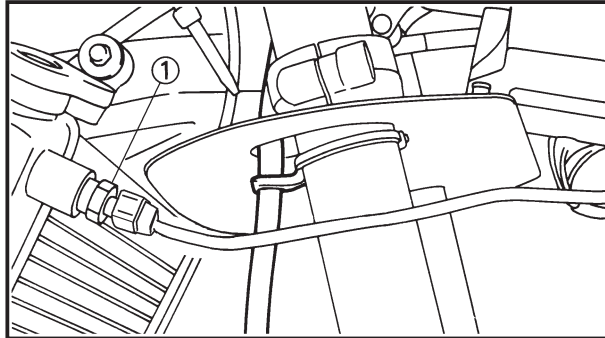

EC6A2000

THERMO UNIT INSPECTION

1. Drain the cooling water.
2. Remove:
 - Thermo unit ①

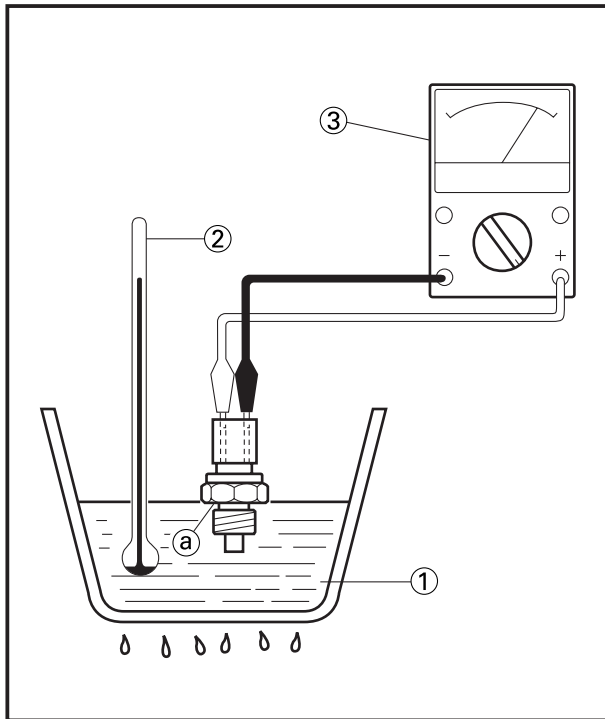

3. Immerse the thermo unit with a tester lead connected in a container containing cooling (tap) water ① down to the upper threaded portion ③.
 - ② Water temperature gauge
 - ③ Poket tester
4. Inspect:
 - Thermo unit resistance
Measure the resistance while gradually heating the cooling water.
Out of specification → Replace .

	Cooling water temperature	Thermo unit resistance	Tester selector position
	50°C (122°F)	9.72~11.4 kΩ	kΩ × 1
	80°C (176°F)	3.41~4.01 kΩ	

NOTE: Do not allow the thermo unit to contact the test container bottom.



EC700000

TUNING

EC710000

ENGINE

EC711011

Carburetor setting

- The role of fuel is not only to produce motive power but also to cool the engine and, in the case of a 2-stroke engine, to lubricate it. Therefore, too lean a mixture (of air and fuel) tends to cause an abnormal combustion (i.e., detonation), whereas too rich a mixture makes it difficult for the engine to develop its full performance, with the result that in some cases the spark plug may be fouled, causing the engine to stop running.
- The richness of the air-fuel mixture required for the engine will vary with atmospheric conditions of the day and therefore, the settings of the carburetor must be properly suited to the atmospheric conditions (air pressure, humidity and temperature).
- As a basic setting method, only the factory set main jet is first changed to check for the discoloration of the spark plug(s) and piston(s) at full throttle in 6th and then the setting is determined at mid-open throttle.
- ※ Recording and storing the data on the settings, weather conditions, road surface conditions of the circuit, lap times, etc. will enable quick setting under different conditions at a later time.

EC712000

Atmospheric conditions and carburetor setting

Air temp.	Humidity	Air pressure (altitude)	Mixture	Setting
High	High	Low (high)	Richer	Leaner
Low	Low	High (low)	Leaner	Richer

The reason for the above tendency is that the richness or leanness of a fuel mixture depends on the density of the air (i.e. the concentration of oxygen in it).



That is:

- Higher temperature expands the air with its resultant reduced density.
- Higher humidity reduces the amount of oxygen in the air by so much of the water vapor in the same air.
- Lower atmospheric pressure (at a high altitude) reduces the density of the air.

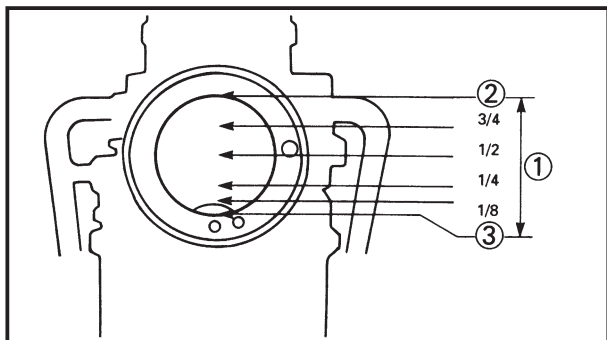

EC714032

Effects of setting parts in relation to throttle valve opening

Setting parts		Throttle valve opening						
		0	1/8	1/4	1/2	3/4	7/8	1/1
Pilot air screw		[Graph showing a decreasing line from left to right]						
Pilot jet		[Graph showing a decreasing line from left to right]						
Jet needle	Diameter of straight portion	[Graph showing a decreasing line from left to right]						
	Clip position	[Graph showing a decreasing line from left to right]						
Power jet		[Graph showing a line that is zero until 1/2, then increases]						
Main jet		[Graph showing a line that is zero until 3/4, then increases]						

NOTE:

The power jet closes at 12,150 rpm of the engine, after which only the main jet dominates.

- ① Throttle valve opening
- ② Full-open
- ③ Full-closed

EC71E011

Basic process of carburetor setting

Ex-factory setting is on the richer side, which should basically have no problems with the brake-in procedure.

Refer to “STARTING AND BREAK-IN” section in the CHAPTER 1.

1. Adjustment of main jet

Use a main jet ① with a smaller calibration number if the engine does not develop more than 12,000 rpm after a few laps of the circuit when the water temperature becomes stable [60°C (140°F) or more].

Example:#220 → #215

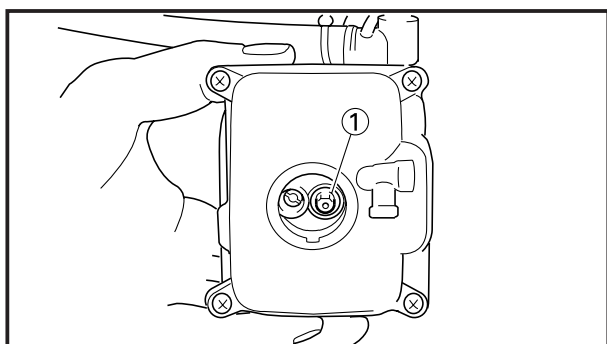



Next run a few laps of the circuit with this setting and check for any difference in engine revolutions. If no difference is noticed, use a main jet with a much smaller calibration number.

Example: #215 → #210

Factory-set main jet	#220
-----------------------------	-------------



2. Checking of spark plug and piston for discoloration

Repeat the adjustment in the above “1” several times. If the engine begins to run at more than 12,000 rpm at full throttle, proceed to the “spark plug chopping” step (refer to P7-9) to check for the discoloration of the spark plug(s) and piston(s).

Refer to the photo for judgment on the discoloration.

As a novice will find it difficult to determine how much smaller number main jet can be used just by looking at discoloration, he should consult an experienced person for his own experience, too.

Whether the setting is proper or not can be judged by engine revolutions.

Approximate criteria for such judgment are given below, on condition that the secondary reduction ratio is fit for conditions of the circuit.

- 13,000 rpm in 1st and 2nd
- 12,500 rpm in 5th and 6th

A Normal

B Over burned (too lean)

C Oil fouled (too rich)

3. Adjustment of jet needle

The jet needle ① adjustment follows the completion of the adjustment of the main jet. Check that engine revolutions smoothly respond to throttle opening from where throttle is about to be opened to 1/2 throttle opening. Use a jet needle of a larger size if engine revolutions appear to falter at the beginning of throttle opening and then suddenly respond to further throttle opening.

Example: N8VH → N8VW

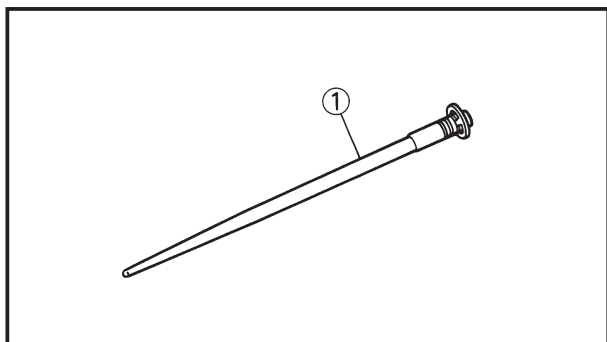



Run a few laps of the circuit to check the engine for response to revolutions.

On the other hand, if the use of a different jet needle appears to produce less power, change to a jet needle of a smaller size.

Example:N8VW → N8VH

Factory-set jet needle	N8VH
------------------------	------

NOTE:

- Refer to “Jet needle” (P7-5) about the jet needle specification.
- Difference between individual riders or difference between circuit layouts greatly affect the jet needle setting.
 1. Rider who frequently uses mid-open throttle
 2. Circuit that requires frequent throttle opening and closing
 3. Wet environment

Conditions as mentioned above require a longer period of throttle closing, resulting in the drawn in mixture staying longer in the crankcase. Such setting in turn will inevitably cause the mixture to be richer at the next throttle opening, a jet needle of a larger size has to be used.

Example of jet needle setting

Month \ Jet needle	1	2	3	4	5	6	7	8	9	10	11	12
N8VH or N8WH	■											
N8VW or N8WW	■	■										■
N8VJ or N8WJ				■					■			
N8VK or N8WK						■						

The above settings are an example of the results obtained on our test course, and are just for reference.

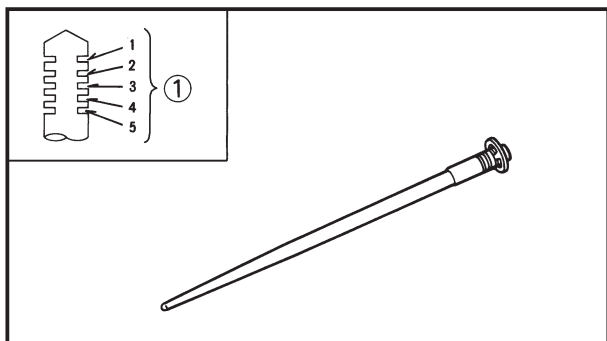

4. Adjustment of jet needle clip position
 Mid-open adjustment for the jet needle clip position ① follows the completion of the adjustment of the jet needle. If the mixture is too rich or too lean in the mid-open position, irregular engine operation and poor acceleration will result. Whether or not the richness of the mixture is proper is hard to be determined by means of the spark plug and therefore, it should be judged from your feeling of actual engine operation.

- Too rich in the mid-open position (Rough engine operation is felt and the engine will not pick up speed smoothly)
 Step up the jet needle clip by one groove and move down the needle to lean out the mixture.
- Too lean in the mid-open position (The engine breathes hard and will not pick up speed quickly)
 Step up the jet needle clip by one groove and move up the needle to enrich the mixture.

Factory-set clip position	No.3 Groove
----------------------------------	--------------------

EC71S000

Jet needle

On the carburetors used in the TZ125, the main nozzle is press-fitted, so it can not be replaced. Therefore, carburetor setting requires the change of the jet needle.

The jet needle setting parts, having the same taper angle, are available in different straight portion diameters and in different taper starting positions.

Example:

N8VH-3

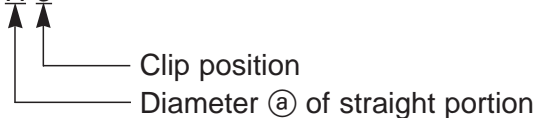

④ Jet needle number

NOTE:

Changing from N8VH to N8WH has the same effect as raising the clip position by half.

Example:

The 3rd position of N8WH corresponds to the 2.5th position of N8VH.

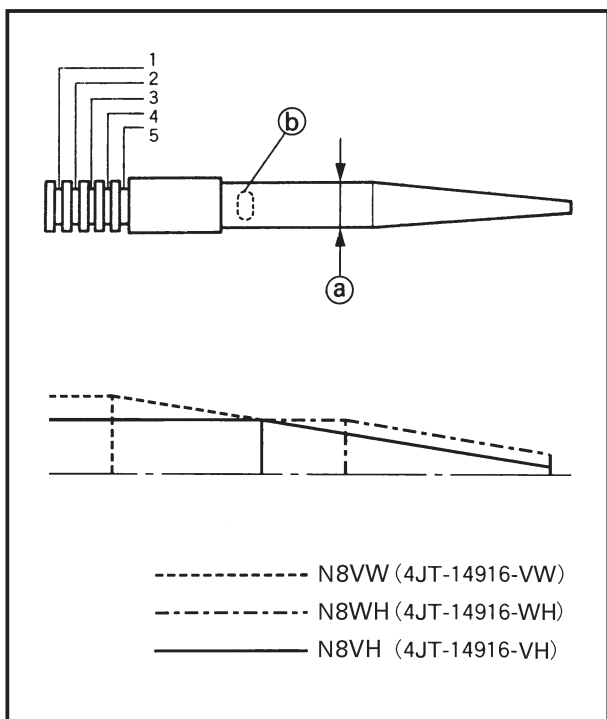

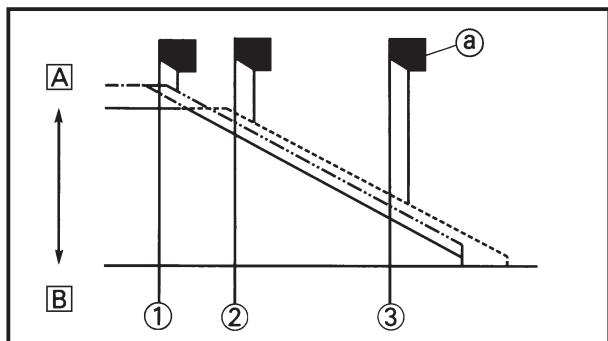

EC71B030

Relationship with throttle opening

The flow of the fuel through the carburetor main system is controlled by the main jet and then, it is further regulated by the area between the main nozzle and the jet needle. On the relationship between the fuel flow and the throttle opening, the fuel flow relates to the jet needle straight portion diameter around 1/8 throttle opening, whereas around 1/4 to 1/2 throttle opening it relates to the taper starting position and to the clip position.

Therefore, the fuel flow is balanced at each stage of throttle opening by the combination of the jet needle straight portion diameter, taper starting position and clip position.

Example:

- N8WW-3rd groove
- N8VW-3rd groove
- N8VH-2nd groove
- N8VH-3rd groove

- [A] Lean (larger diameter)
- [B] Rich (smaller diameter)
- ① 1/8 throttle
- ② 1/4 throttle
- ③ 1/2 throttle
- [a] Main nozzle

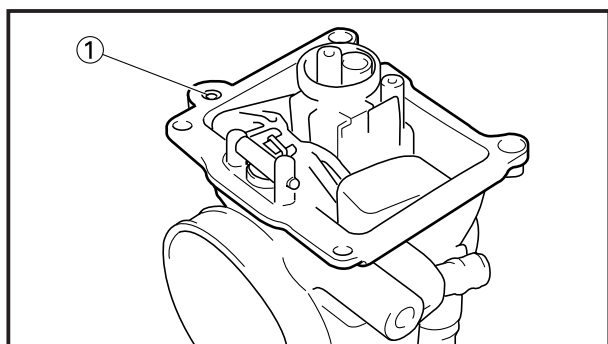

EC71H031

Other setting parts

1. Power jet ①

Use a power jet of a smaller size if in the main jet adjusting, no good response is achieved just after shifting up gear even though the engine is running properly and if there is an allowance for the discoloration of the spark plug(s) and piston(s).

A larger size results in a richer mixture and a smaller size in a leaner mixture around 12,000 rpm.

Factory-set power jet	#60
------------------------------	------------

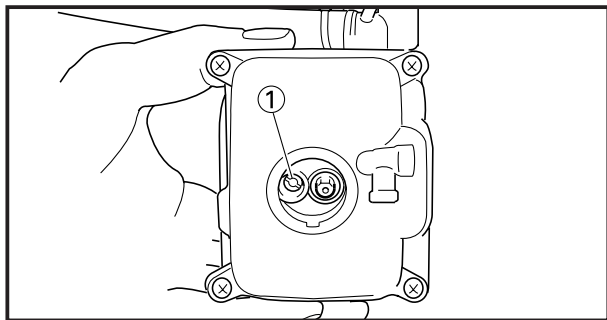

2. Pilot jet ①

The pilot jet is used in relation to the engine response at small throttle opening. This is changed when the jet needle setting is not enough.

A larger size results in a richer mixture and a smaller size in a leaner mixture.

Factory-set pilot jet	#42
------------------------------	------------

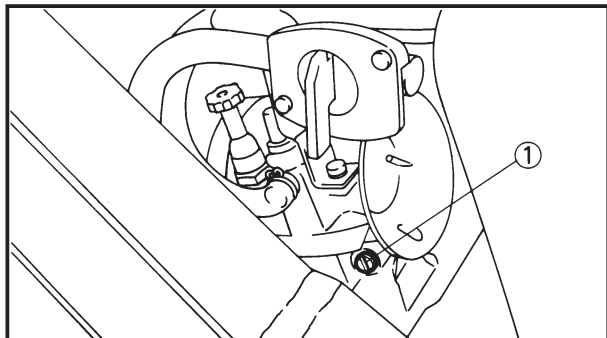

3. Pilot air screw ①

The pilot air screw relates to the engine response at a smaller opening than for the pilot jet.

This setting may be changed for want of time or in emergency, but it is basically set at the factory-set pilot air screw position.

Factory-set pilot air screw position	Factory set
---	--------------------

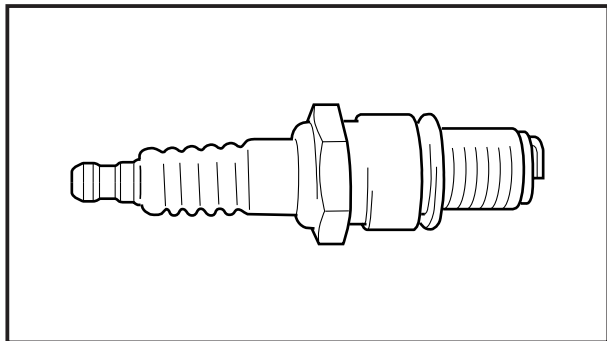

4. Spark plug

The spark plug heat range is not basically changed.

Constant attention to the discoloration of the spark plug and piston head will enable you to tell to some extent whether the setting is good or bad.

Standard spark plug	R6385-105P/NGK
----------------------------	-----------------------

NOTE: _____
 For the effects each setting part has, refer to "Effects of setting parts in relation to throttle valve opening" (P7-2).

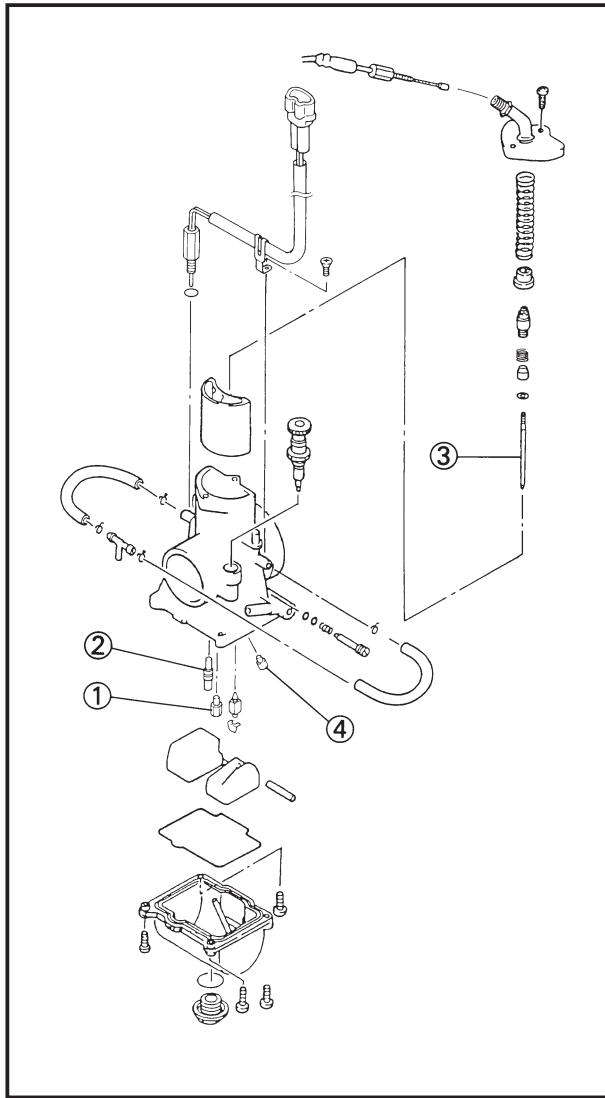

EC71Q000

Carburetor setting parts

Part name	Size	Part number	
Main jet ①	Lean ↑ ↓ * Rich	#160 4MX-14943-39	
		#162 4MX-14943-90	
		#165 4MX-14943-40	
		#168 4MX-14943-91	
		#170 4MX-14943-41	
		#172 4MX-14943-92	
		#175 4MX-14943-42	
		#178 4MX-14943-93	
		#180 4MX-14943-43	
		#182 4MX-14943-94	
		#185 4MX-14943-44	
		#188 4MX-14943-95	
		#190 4MX-14943-45	
		#192 4MX-14943-96	
		#195 4MX-14943-46	
		#198 4MX-14943-97	
		#200 4MX-14943-47	
		#205 4MX-14943-48	
		#210 4MX-14943-49	
		#215 4MX-14943-50	
* Rich	#220 4MX-14943-51		
Pilot jet ②	Lean ↑ ↓ * Rich	#38 4SR-14948-02	
		#40 4SR-14948-03	
		#42 4MX-14948-04	
Jet needle ③	Lean ↑ ↓ * Rich Lean ↑ ↓ Rich	N8VK 4JT-14916-VK	
		N8VJ 4JT-14916-VJ	
		N8VW 4JT-14916-VW	
		* Rich	N8VH 4JT-14916-VH
		Lean	N8WK 4JT-14916-WK
		N8WJ 4JT-14916-WJ	
		N8WW 4JT-14916-WW	
		Rich	N8WH 4JT-14916-WH
Power jet ④	Lean ↑ ↓ * Rich	#40 4JT-1494F-03	
		#50 4JT-1494F-07	
		#60 4JT-1494F-11	

* Factory installed



EC71J001

Plug chop

When checking the discoloration of the spark plug and piston head, push the “ENGINE STOP” button while running along a straight lane at full throttle, disengage the clutch at the same time and stop the engine. Then let your machine go back to the pit by inertia. This is called a “plug chop”.

CAUTION: _____

- **When you do a “plug chop”, pay attention to your surrounding environment to avoid interference with other riders.**
- **Do not shift down while riding your machine by inertia (as it may cause a seizure of the clutch push rod and ball).**

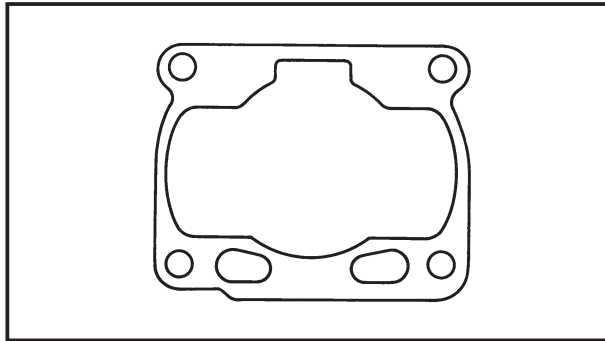

EC71K003

Setting of cylinder gasket

The use of the supplied gaskets of different thicknesses makes it possible to change the combustion chamber volume to deal with changing weather conditions.

Not much torque is felt with slow engine acceleration → Reduce the combustion chamber volume.

Torque is felt with no higher revolutions → Expand the combustion chamber volume.

Thickness	Actual combustion chamber volume	Type
0.8 mm (0.031 in)	Approx. 9.42 cm ³ (0.332 Imp oz, 0.318 US oz)	STD
0.7 mm (0.028 in)	Approx. 9.19 cm ³ (0.323 Imp oz, 0.311 US oz)	Supplying parts
0.6 mm (0.024 in)	Approx. 8.96 cm ³ (0.315 Imp oz, 0.303 US oz)	

NOTE: _____

- Finish adjusting the carburetor setting before changing the gasket.
- A change of 0.1 mm (0.004 in) for the gasket causes a change of approximately 0.23 cm³ (0.0081 Imp oz, 0.0078 US oz) of the combustion chamber volume.

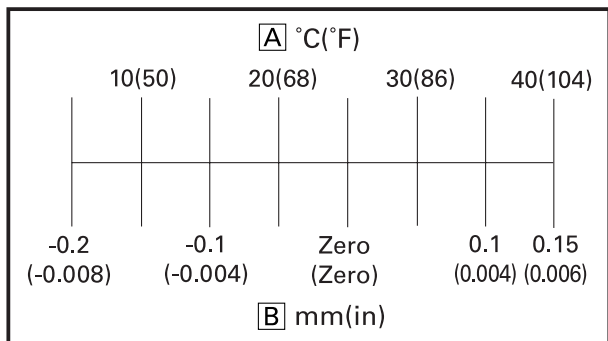

When the cylinder gasket is changed, measure the protruding (or sinking) amount of the piston above (below) the cylinder top and then change the cylinder gasket so that the following approximate relation can be achieved between the temperature and the piston protruding amount. (The table shows an example when the air pressure is 1013 hPa (760 mmHg).)

CAUTION:

- Piston protruding amount must be a maximum 0.15 mm (0.006 in). Above this value, the piston and cylinder head may contact each other.
- As the air pressure becomes lower at a higher altitude, slide to the right the temperature scale readings by 10°C (50°F) each for every change in the air pressure of 27 hPa (20 mmHg).
- Too much random piston protrusion at low temperature may develop an abnormal combustion (detonation), which may adversely affect the intended performance of the engine.

[A] Air temperature

[B] Piston protruding amount

EC71T000

Cylinder gasket setting parts

Part number	Size (thickness)
4JT-11351-02 *	t=0.8 mm (0.031 in)
4JT-11351-12	t=0.7 mm (0.028 in)
4JT-11351-22	t=0.6 mm (0.024 in)

* Factory installed

EC71L002

Measuring piston protrusion

1. Install the dial gauge ① and dial gauge stand ② to the cylinder contact surface and set the scale of the dial gauge to zero.

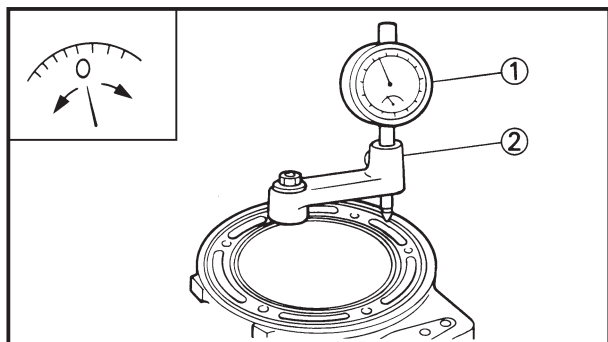

Dial gauge:
YU-03097/90890-01252
Stand:
YU-01256

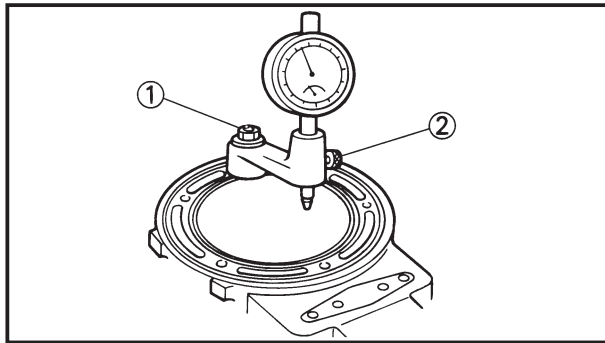

2. Loosen the stand installation bolt ①, then rotate the dial gauge stand and set it close to the center of the piston. Tighten the stand installation bolt again.

NOTE: _____

Do not loosen the dial gauge installation bolt ② while doing the above.

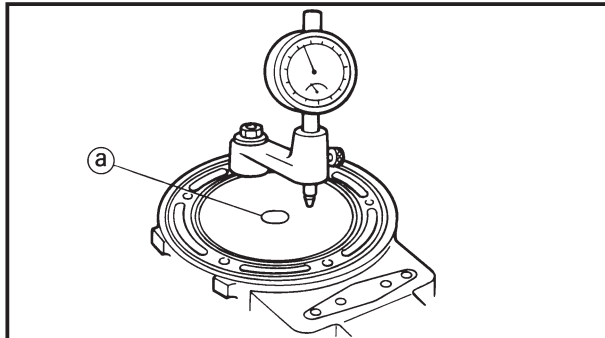

3. Set the piston at top dead center (TDC), then measure the piston protrusion.

NOTE: _____

For measurement, avoid the top center projected area (a) on the piston head but measure several positions above the piston pin as close to the center as possible. The average of these measurements indicates the piston protrusion.

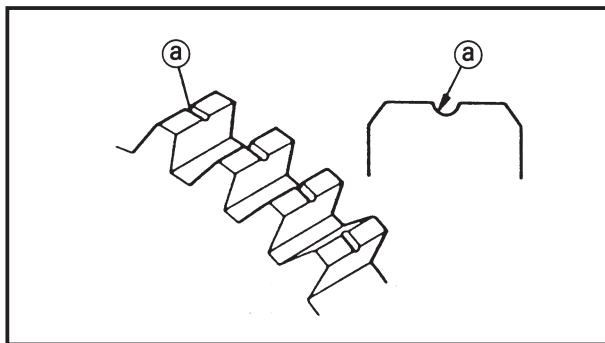

EC71N001

Selection of transmission gear ratio

The following gear sets are contained in the packing (or optional) to allow the rider to change the gear ratios according to the circuit condition or rider's preference.

CAUTION: _____

Select the transmission gears so that the number of grooves in the wheel gear match that of the pinion gear as shown below. Trouble may be occurred if the selection is different than that listed below.

① Groove

1st gear

	Gear ratio	Part number	Number of groove
Factory installed	30/15 (2.000)	4JT-17211-00/4JT-17411-00	—
Supplying part	29/15 (1.933)	4JT-17211-10/4JT-17411-00	1/—

2nd gear

	Gear ratio	Part number	Number of groove
Supplying part	35/21 (1.667)	4JT-17221-00/4JT-17121-00	—
Factory installed	31/19 (1.632)	4JT-17221-30/4JT-17121-30	—
Supplying part	27/17 (1.588)	4JT-17221-10/4JT-17121-10	1

**3rd gear**

	Gear ratio	Part number	Number of groove
Supplying part	23/16 (1.438)	4JT-17231-00/4JT-17131-00	–
Factory installed	24/17 (1.412)	4JT-17231-30/4JT-17131-30	–
Supplying part	26/19 (1.316)	4JT-17231-10/4JT-17131-10	1

4th gear

	Gear ratio	Part number	Number of groove
Supplying part	28/22 (1.278)	4JT-17241-00/4JT-17131-00	–
Factory installed	25/20 (1.250)	4JT-17241-30/4JT-17131-30	–
Supplying part	27/22 (1.227)	4JT-17241-10/4JT-17131-10	1

5th gear

	Gear ratio	Part number	Number of groove
Factory installed	24/21 (1.143)	4JT-17251-30/4JT-17151-20	–/2
Supplying part	26/23 (1.130)	4JT-17251-10/4JT-17151-10	1

6th gear

	Gear ratio	Part number	Number of groove
Factory installed	26/24 (1.083)	4JT-17261-30/4JT-17161-30	–
Supplying part	23/22 (1.045)	4JT-17261-00/4JT-17161-20	–/2

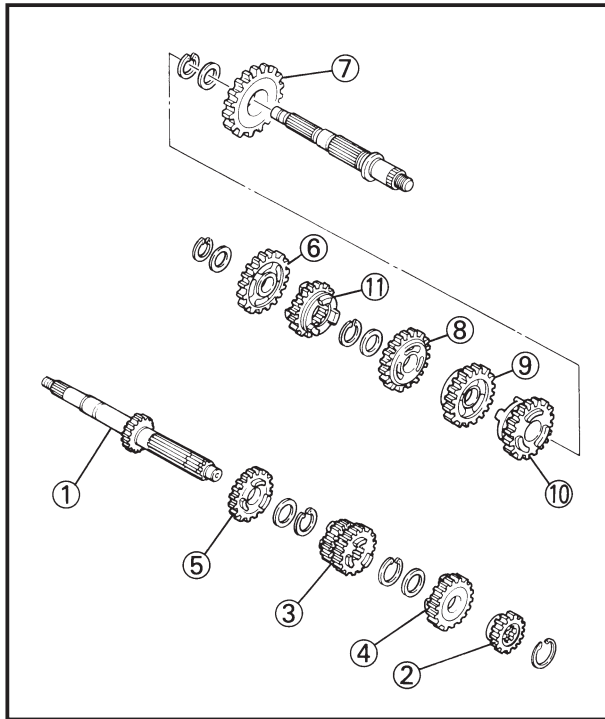

EC71U000

Transmission setting parts

Part name	Size	Part number
Main axle ①	* 15T	4JT-17411-00
2nd pinion gear ②	* 17T	4JT-17121-10
	* 19T	4JT-17121-30
	21T	4JT-17121-00
3rd/4th pinion gear ③	16T/22T	4JT-17131-00
	* 17T/20T	4JT-17131-30
	Δ 19T/20T	4JT-17131-21
	19T/22T	4JT-17131-10
5th pinion gear ④	* 21T	4JT-17151-20
	23T	4JT-17151-10
	Δ 26T	4JT-17151-00
6th pinion gear ⑤	Δ 21T	4JT-17161-00
	Δ 22T	4JT-17161-20
	* 24T	4JT-17161-30
	27T	4JT-17161-11
1st wheel gear ⑥	29T	4JT-17211-10
	* 30T	4JT-17211-00
2nd wheel gear ⑦	* 27T	4JT-17221-10
	* 31T	4JT-17221-30
	35T	4JT-17221-00
3rd wheel gear ⑧	23T	4JT-17231-00
	* 24T	4JT-17231-30
	Δ 25T	4JT-17231-20
	26T	4JT-17231-10
4th wheel gear ⑨	Δ 24T	4JT-17241-20
	* 25T	4JT-17241-30
	27T	4JT-17241-10
	28T	4JT-17241-00
5th wheel gear ⑩	* 24T	4JT-17251-30
	26T	4JT-17251-10
	Δ 30T	4JT-17251-00
6th wheel gear ⑪	Δ 23T	4JT-17261-00
	* 26T	4JT-17261-30
	29T	4JT-17261-11

* Factory installed

NOTE:

The mark Δ shows that this part is not supplied together and that it is available on order as a YAMAHA genuine part.



EC720000

CHASSIS

EC72J001

Chassis setting

How to go about setting the chassis

- Measure the stroke of the front and rear suspension to get an idea of the operation.
- If the time increases, the stroke increases.
- If the tire grip becomes firmer, the stroke increases.

(On the other hand, the stroke decreases on rainy weather.)

- Rider's position and posture affect the stroke.
- Be careful not to allow the suspension to bottom out.
- Start the setting with the preload.

Next, go to the damping force adjustment, and if this not enough, then adjust the machine height.

(On the side where the machine height is greater the stroke increases; whereas it decreases on the side with a smaller machine height.)

- If the damping force is increased either on the compression or the expansion side, it results in less smooth movement, so do not depart too far from the standard settings.
- Adjust the machine height in an increment of mm (in).
- If you lose your way while doing the setting, go back to the standard settings.
- Oil level adjustment in the front fork produces a greater effect in further stroke than in mid stroke.

(Increase or decrease the oil level in an approximately 5~10 mm (0.20~0.39 in) interval.)

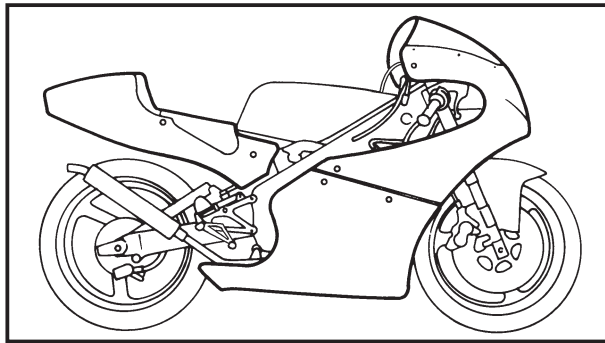

EC72M001

Tire and machine's posture

If a non-designated tire is used, the difference in radius between the front and the rear tire may affect the machine's posture.

To keep the machine in a proper posture, adjust the front fork top end or seat height.

Basically, with a larger radius tire, lower the machine's posture and vice versa.

[Front]

Tire brand	Tire circumference	Tire radius	Front fork top end
95/70R17 DUNLOP KR149	About 1,810 mm (71.3 in)	About 288 mm (11.3 in)	18 mm (0.71 in)

[Rear]

Tire brand	Tire circumference	Tire radius	Seat height
125/55R17 DUNLOP KR133	About 1,869 mm (73.6 in)	About 297 mm (11.7 in)	19 mm (0.75 in)

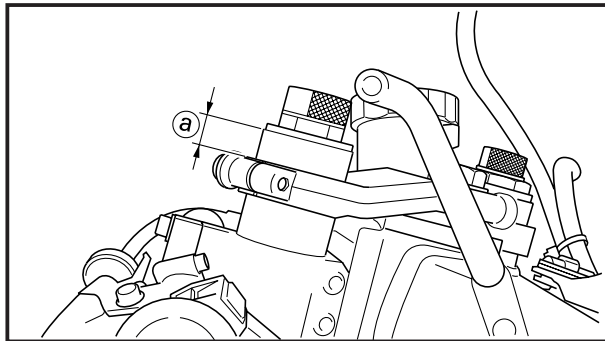

Example:

If the front tire radius is 1 mm (0.04 in) larger, lower the front posture by 1 mm (0.04 in) by increasing the front fork top end ① by 1 mm (0.04 in). If the rear tire radius is 2 mm (0.08 in) smaller, raise the rear posture by 2 mm (0.08 in) by decreasing the adjuster set length ② by 1 mm (0.04 in).

NOTE:

- Find the tire radius by calculating the measured circumference of the tire.
- A change of 1 mm (0.04 in) in the front fork top end results in a change of about 1 mm (0.04 in) in the front posture. A change of 1 mm (0.04 in) in the adjuster set length results in a change of about 2 mm (0.08 in) in the rear posture.

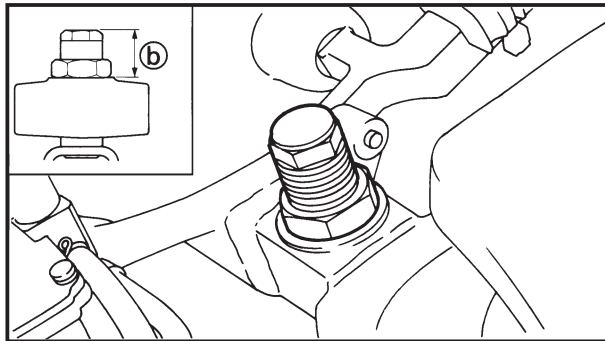



EC72K014

Settings

For full use of engine performance and safe riding, set the suspension as follows. (Ex-factory settings are intended for a rider approximately 164 cm (64.6 in) in height and approximately 53 kg (117 lb) in weight.)

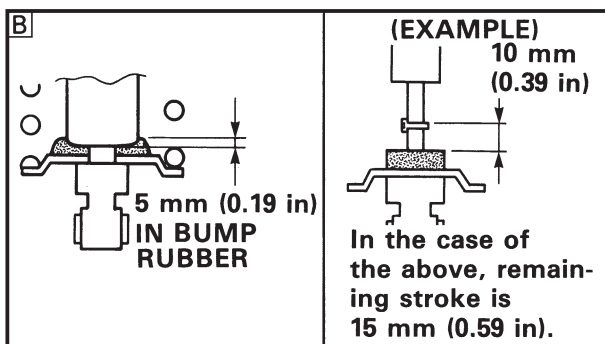
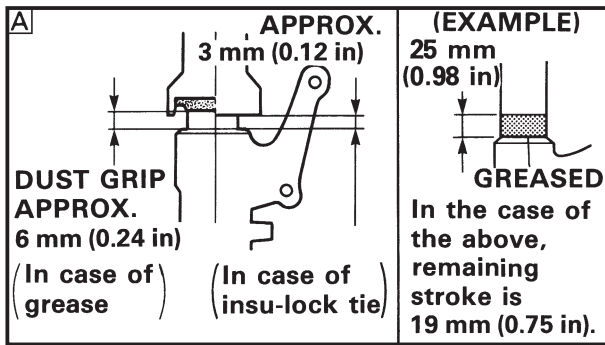
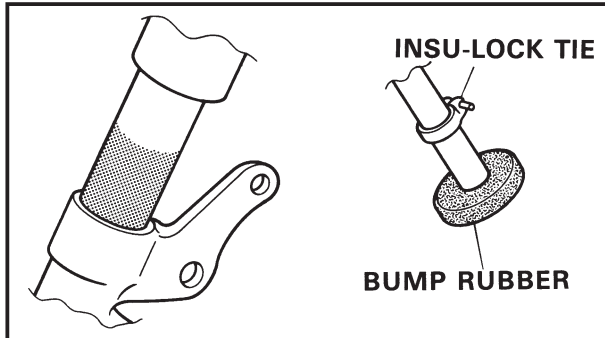

1. Preparations

To check for the remaining stroke in the front and rear suspension, either install a thin insu-lock tie or apply a small amount of grease at the front fork inner tube and at the rear shock absorber rod.

2. Settings

At the beginning of the break-in period, always record the remaining stroke as data. To judge front and rear balance in relation to the machine height, the usual way is to shift from full braking to turning and get the feel when the clipper riding.

After making an actual run, proceed to the settings for a target of a 5~10 mm (0.20~0.39 in) remaining stroke for front and a 20 ~ 30 mm (0.79~1.18 in) remaining stroke for rear.

Basically, the best settings can be obtained by repeating the following steps.

NOTE:

The figures show the bottom-out positions of the front and rear suspension.

A Front

B Rear



SETTING CHART

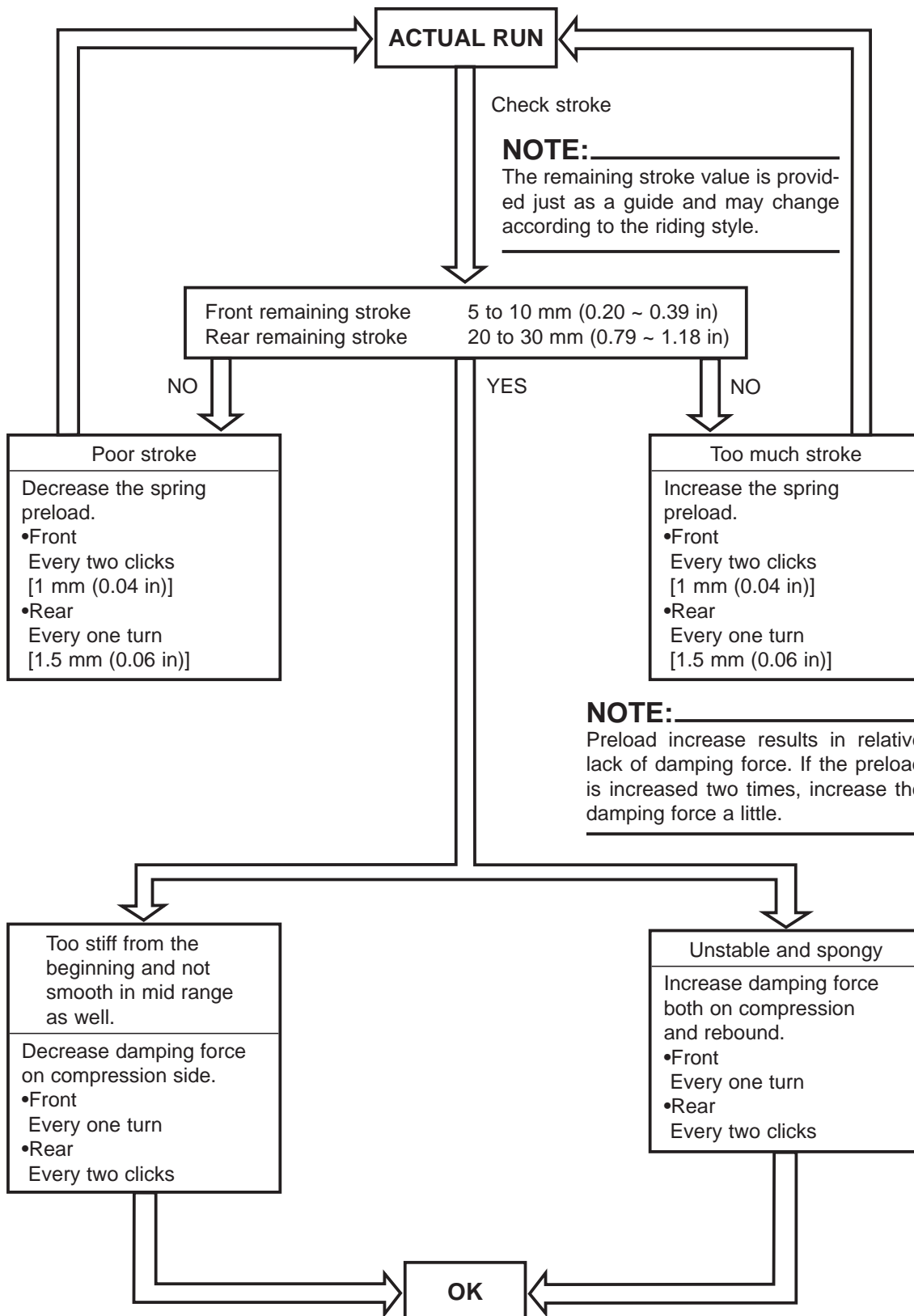



EC71P011

Selection of the secondary reduction ratio (Sprocket)

$$\text{Secondary reduction ratio} = \frac{\text{Number of driven sprocket teeth}}{\text{Number of drive sprocket teeth}}$$

Factory-set secondary reduction ratio	36/17 (2.118)
--	----------------------

	Driven sprocket	35T	36T	37T	38T	39T
Drive sprocket	16T	2.188	2.250	2.313	2.375	2.438
	17T	2.059	2.118	2.177	2.235	2.294
	18T	1.944	2.000	2.056	2.111	2.167

The larger value, the higher speed ratio
The smaller value, the lower speed ratio

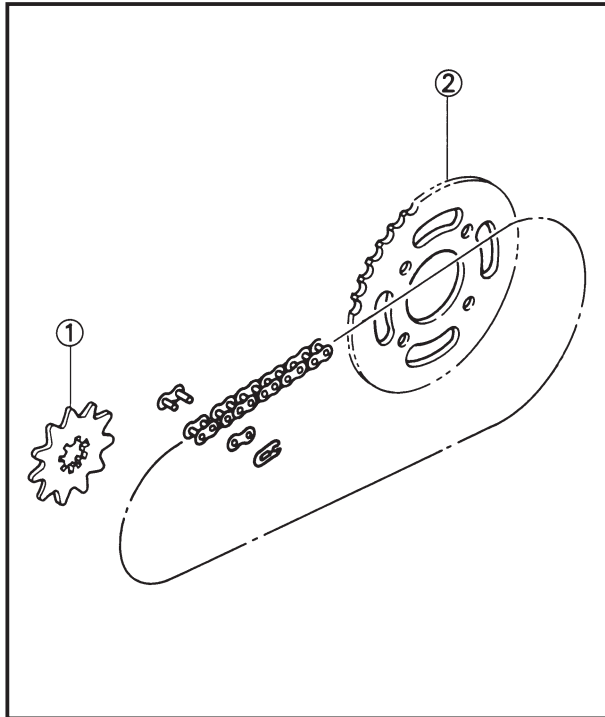

EC72N000

Drive and driven sprockets setting parts

Part name	Size	Part number
Drive sprocket ①	16T	938AA-16198
	17T	938AA-17196
	18T	938AA-18199
Driven sprocket ②	35T	4JT-25435-20
	36T	4JT-25436-20
	37T	4JT-25437-20
	38T	4JT-25438-20
	39T	4JT-25439-20

* Factory installed



EC72L003

Chassis setting troubleshooting

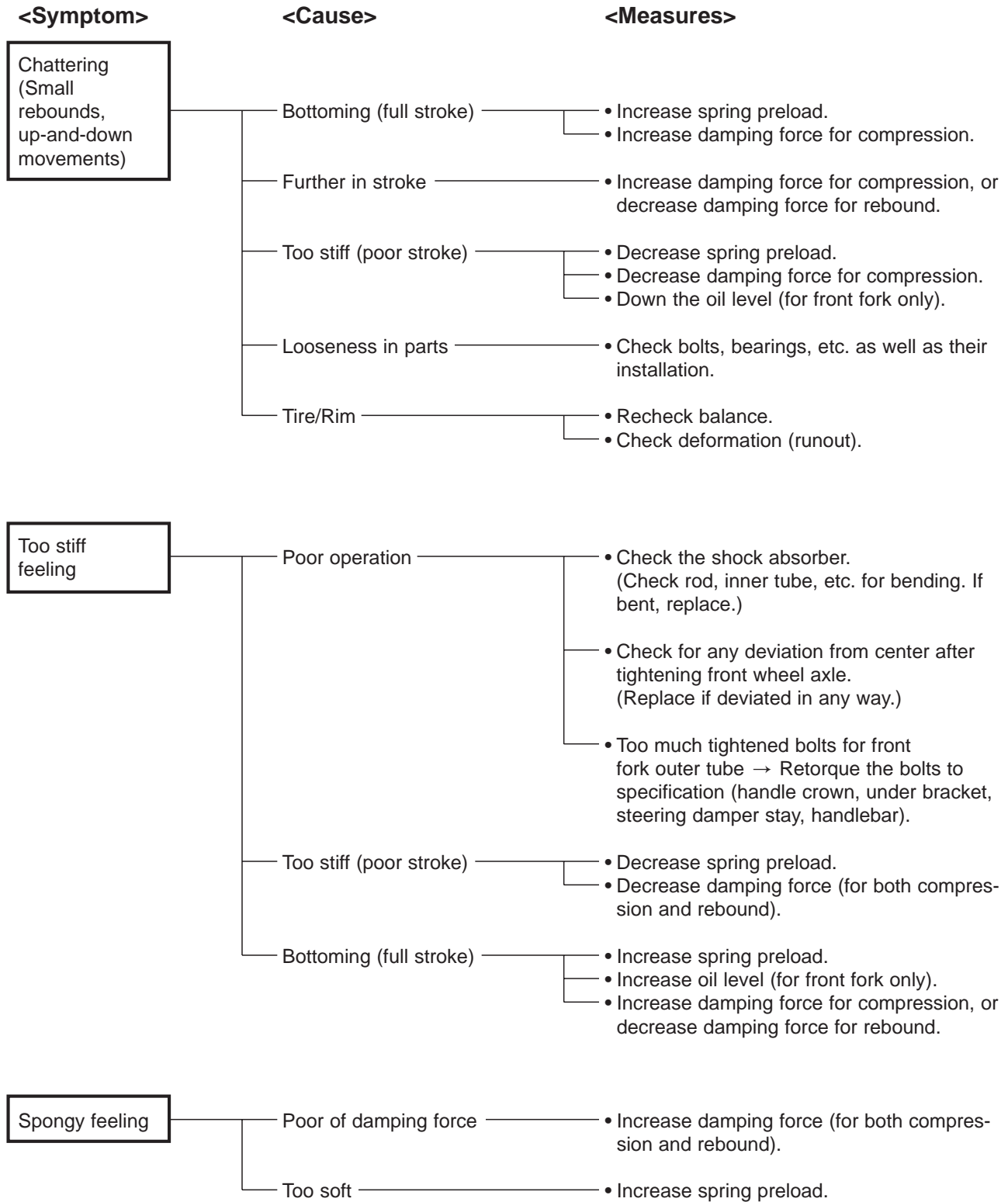

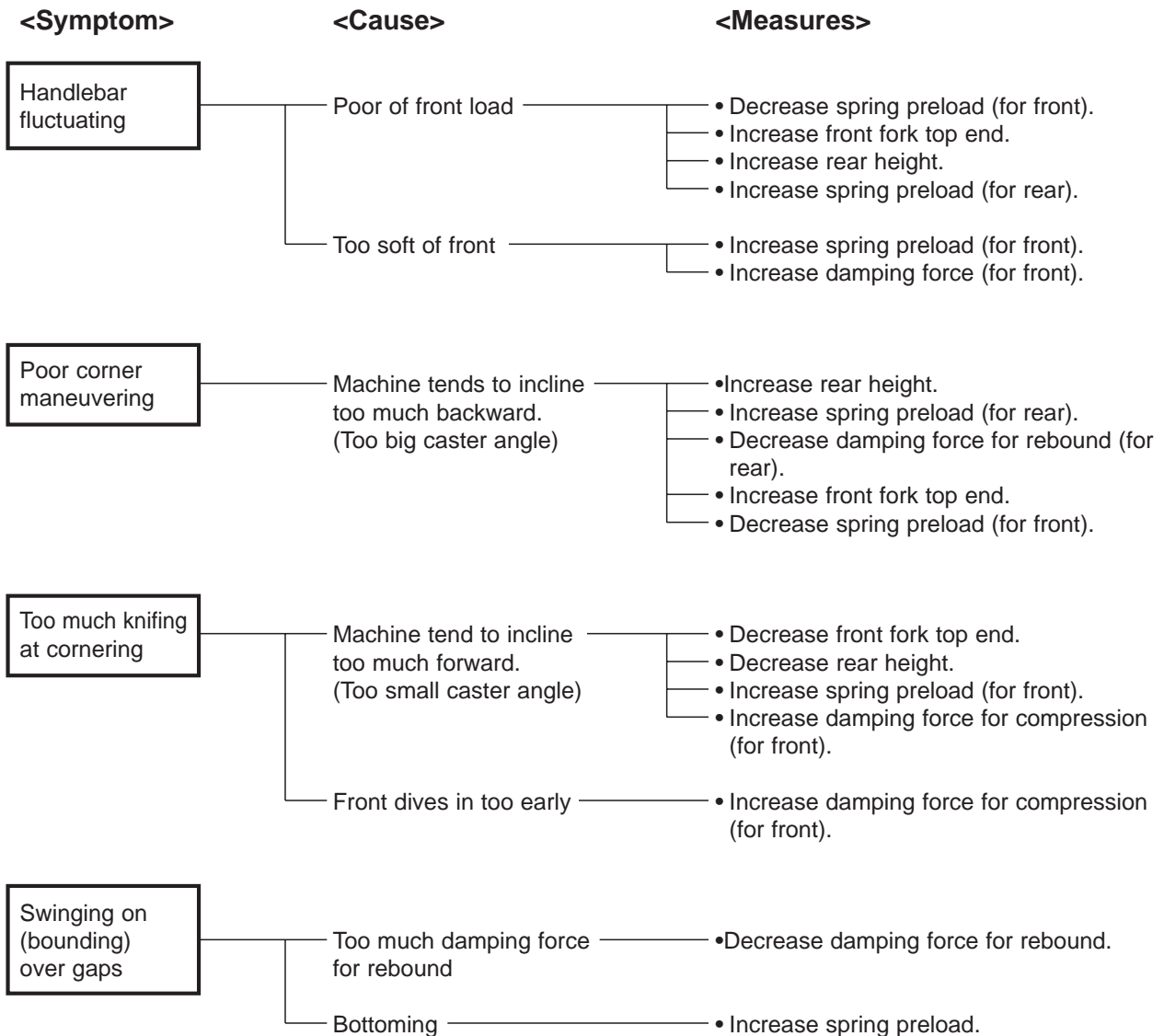



EC740010

Setting record table

The data shown here is an example of entry. For your actual use, copy the necessary data.

Event name				
Date				
Weather				
Place				

Setting specs:

Ignition timing				
Spark plug				
Carburetor Main jet Power jet Jet needle Pilot jet Pilot air screw Float height				
Gearing 1st 2nd 3rd 4th 5th 6th Secondary				
Front fork Spring rate Spring preload Rebound damping Compression damping Top end Oil capacity Oil level				
Rear shock Spring fitting length Spring rate Rebound damping Compression damping Seat height				
Front tire (pressure)				
Rear tire (pressure)				
Fuel consumption				



Event name				
Date				
Weather				
Place				

Setting specs:

Ignition timing				
Spark plug				
Carburetor Main jet Power jet Jet needle Pilot jet Pilot air screw Float height				
Gearing 1st 2nd 3rd 4th 5th 6th Secondary				
Front fork Spring rate Spring preload Rebound damping Compression damping Top end Oil capacity Oil level				
Rear shock Spring fitting length Spring rate Rebound damping Compression damping Seat height				
Front tire (pressure)				
Rear tire (pressure)				
Fuel consumption				

NOTE:

1. Make setting changes in small increments.
2. When the proper settings have been determined for a particular track, they should be written down for reference upon returning to that track.
3. Always make adjustment in cold state.

PROTECT YOUR INVESTMENT

Use Genuine YAMAHA Parts And Accessories



YAMAHA

YAMAHA MOTOR CO., LTD.

2500 SHINGAI IWATA SHIZUOKA JAPAN

PRINTED ON RECYCLED PAPER

www.legends-yamaha-enduros.com

PRINTED IN JAPAN
99.8-0.1x1 
(E)