

MINI ENDURO JT1

www.legends-yamaha-enduros.com

YAMAHA

NOTICE

This manual has been written by Yamaha Motor Company for use by Authorized Yamaha Dealers and their qualified mechanics. In light of this purpose it has been assumed that certain basic mechanical precepts and procedures inherent to our product are already known and understood by the reader.

Without such basic knowledge, repairs or service to this model may render the machine unsafe, and for this reason we must advise that all repairs and/or service be performed by an Authorized Yamaha dealer who is in possession of the requisite basic product knowledge. Other information is produced by the U. S. distributor, Yamaha International Corporation, and is necessary to provide total technical coverage regarding the product. The Research, Engineering, and Service Departments of Yamaha are continually striving to further improve all models manufactured by the company. Modifications are therefore inevitable and changes in specifications or procedures will be forwarded to all Authorized Yamaha Dealers and will, where applicable, appear in future editions of this manual.

www.legends-yamaha-enduros.com

YAMAHA JT1 SERVICE MANUAL

1st. Edition

August 1970

SERVICE DEPARTMENT

YAMAHA MOTOR CO., LTD.
1280 NAKAJO HAMAKITA JAPAN

FOREWORD

The new YAMAHA MINI ENDURO, though small in size, is a fully functional motorcycle in the Yamaha Enduro vein. The 60cc engine, four speed gearbox, tubular frame and fully functional suspension combine to provide an ideal vehicle for the younger rider.

Its rugged design and excellent performance also make it an intriguing diversion for older, more experienced riders as well.

This service manual has been prepared in order to provide all Yamaha dealers and their service technicians the repair instructions and technical information required to keep the MINI-ENDURO in top condition. We hope that you will find this manual most helpful and valuable in carrying out this goal.

www.legends-yamaha-enduros.com

YAMAHA MOTOR CO., LTD.
SERVICE DIVISION

CONTENTS

CHAPTER 1 GENERAL	1
1- 1 Profile	1
1- 2 Features	2
1- 3 Specifications and Performance	3
1- 4 Performance Curves	5
1- 5 Tools and Instrument for shop service	6
CHAPTER 2 YAMAHA AUTOLUBE	7
2- 1 What is Yamaha Autolube?	7
2- 2 Features of Yamaha Autolube	7
2- 3 Handling the Oil Pump	7
CHAPTER 3 ENGINE	11
3- 1 Engine Removal	11
3- 2 Cylinder Head	15
3- 3 Cylinder	16
3- 4 Piston Pin	17
3- 5 Piston Ring	18
3- 6 Piston	19
3- 7 Flywheel Magneto	20
3- 8 Crankcase Cover (R.H.)	21
3- 9 Clutch	22
3-10 Primary Drive Gear	27
3-11 Kick Starter Mechanism	27
3-12 Shift Mechanism	29
3-13 Rotary Valve	31
3-14 Drive Sprocket	33
3-15 Crankcase	35
3-16 Transmission Assembly	36
3-17 Crankshaft	38
3-18 Bearing and Oil Seals	41
3-19 Carburetor	42

3-20 Air Cleaner	44
CHAPTER 4 CHASSIS	46
4- 1 Front Wheel	46
4- 2 Rear Wheel	49
4- 3 Rear Wheel Sprocket	53
4- 4 Tires and Tubes	54
4- 5 Front Forks	54
4- 6 Rear Shocks	57
4- 7 Gas Tank	58
4- 8 Rear Swing Arm	58
4- 9 Steering Head	60
4-10 Oil Tank and Tool Box	61
4-11 Frame	61
4-12 Handlebars	61
4-13 Miscellaneous	61
CHAPTER 5 ELECTRICAL SYSTEM	62
5- 1 Description	62
5- 2 Table of Component Parts	62
5- 3 Connection Diagram	62
5- 4 Ignition System	62
5- 5 Ignition Timing	63
5- 6 Ignition Coil	63
5- 7 Condenser	63

CHAPTER 1 GENERAL

1-1 Profile

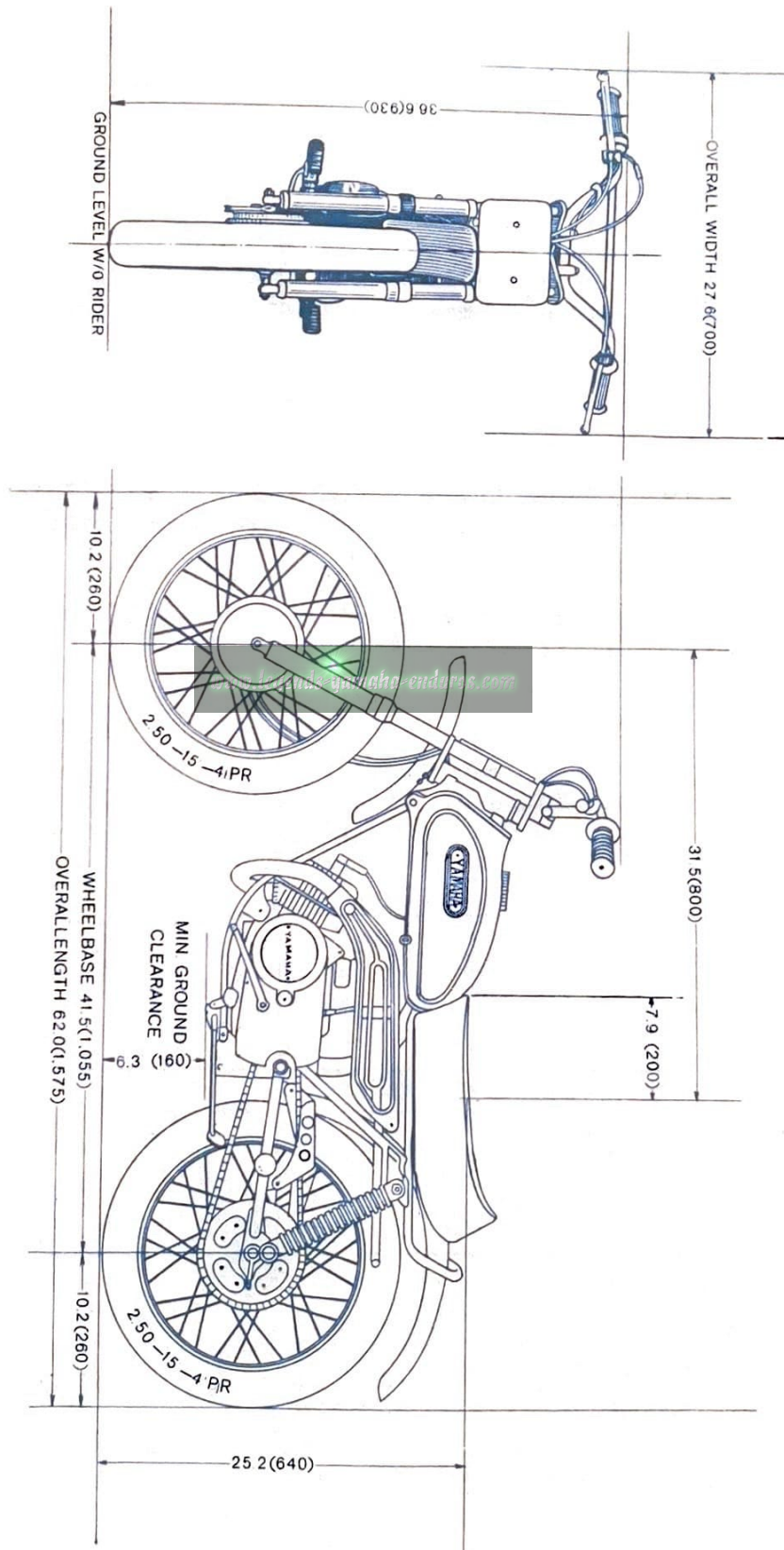

1-2 Features

1. **Highly-dependable Yamaha Autolube**

Yamaha Autolube provides superior engine lubrication that extends the service life of the engine.

2. **Convenient primary kick-starter and magneto ignition system**

A primary-coupled kick-starter lets you start the engine with the transmission in any gear simply squeeze the clutch lever and kick the starter. Starting the engine needs neither battery nor switch.

3. **Powerful Brakes**

Patented waterproof, dustproof brake drums provide safe, fade-free braking on wet or dusty roads.

4. **Front Fork Design**

The Yamaha Enduro 60 JT1 employs a front fork design well-known for its strength and superior handling characteristics. Its use assures the rider of the ultimate in suspension for even the roughest terrain.

5. **Beautiful styling**

Even at a distance you can tell identify a JT1 with ease because of its "sharp" styling and bright color.

6. **Tires**

The Yamaha JT1 is fitted with Trials Universal tires as standard equipment. This particular tread is one of the most versatile available. It gives maximum trail traction, yet is compatible with road usage.

7. **Carburetor Starter Feature**

Yamaha's starter feature is already well-known for providing easy starting. Equipped with this unique carburetor, the Yamaha JT1 is quick starting under all conditions.

www.legends-yamaha-enduros.com

1-3 Specifications & Performance JT1

Model	YAMAHA 60 JT1
Dimensions :	
Overall length	62.0 in. (1575 mm)
Overall width	27.6 in. (700 mm.)
Overall height	36.6 in. (930 mm.)
Wheelbase	41.5 in. (1055 mm.)
Min. ground clearance	6.3 in. (160 mm.)
Weight : Net	121 lbs. (55 kg)
Gross	132 lbs. (160 kg)
Performance :	
Fuel consumption (on paved level roads)	17.6 mile/gal (19 mph)
Climbing ability	22 degrees
Min. turning radius	59.1 in. (1,500 mm.)
Braking distance	24.6 ft/22 mph (7.5 m/35 km/h)
Engine :	
Model	JT1
Type	2 stroke, gasoline
Lubricating system	Separate lubrication (YAMAHA Autolube)
Cylinder	Single, forward inclined.
Displacement	3.54 cu. in. (58 cc)
Bore x Stroke	1.654 in x 1.654 in. (42 mm x 42 mm)
Compression ratio	6.4 : 1
Max. power	4.5 hp/7,500 r.p.m.
Max. torque	3.62 ft-lb/5,500 r.p.m (0.5 kg-m/5,500 r.p.m)
Starting system	Kick starter
Ignition system	Magneto ignition
Ignition timing	1.8 mm. B.T.D.C.
Carburetor :	
Type	Y16P
M. J.	#86
J. N.	32 - 2
Air cleaner :	Wet , foam rubber
Transmission :	
Clutch	Wet , multiple-disk
Primary reduction system	Gear
Primary reduction ratio	3.895 (74/19)

GENERAL - Specifications and Performance

Model	YAMAHA 60 JT1
Gear box : Type Reduction ratio 1st 2nd 3rd 4th Secondary reduction system Secondary reduction ratio Oil capacity	Constant mesh, 4-speed forward 3.077 (40/13) 1.889 (34/18) 1.304 (30/23) 1.038 (27/26) Chain 3.153 (41/13) 0.64 U.S. qts (600cc)
Chassis : Frame Suspensino system ,front Suspension system, rear Cushion system, front Cushion system, rear	Tubular-Double loop Telescopic fork Swinging arm Coil spring, oil damper Coil spring, oil damper
Steering system : Steering angle Caster Trail	47° both right and left 63.5° 2.7 in.(68mm)
Braking system : Type of brake Operation system, front Operation system, rear	Internal expansion Right hand operation Right foot operation
Tire size : Front Rear	www.legends-yamaha-enduras.com 2.50-15-4PR 2.50-15-4PR
Dynamo : Model Manufacturer	F11-L42 HITACHI Ltd.
Tanks : Gasoline tank capacity Oil tank capacity	1.1 U.S. gals (4.3 l) 1.1 U.S. qts (1.0 l)

1-4 PERFORMANCE CURVES

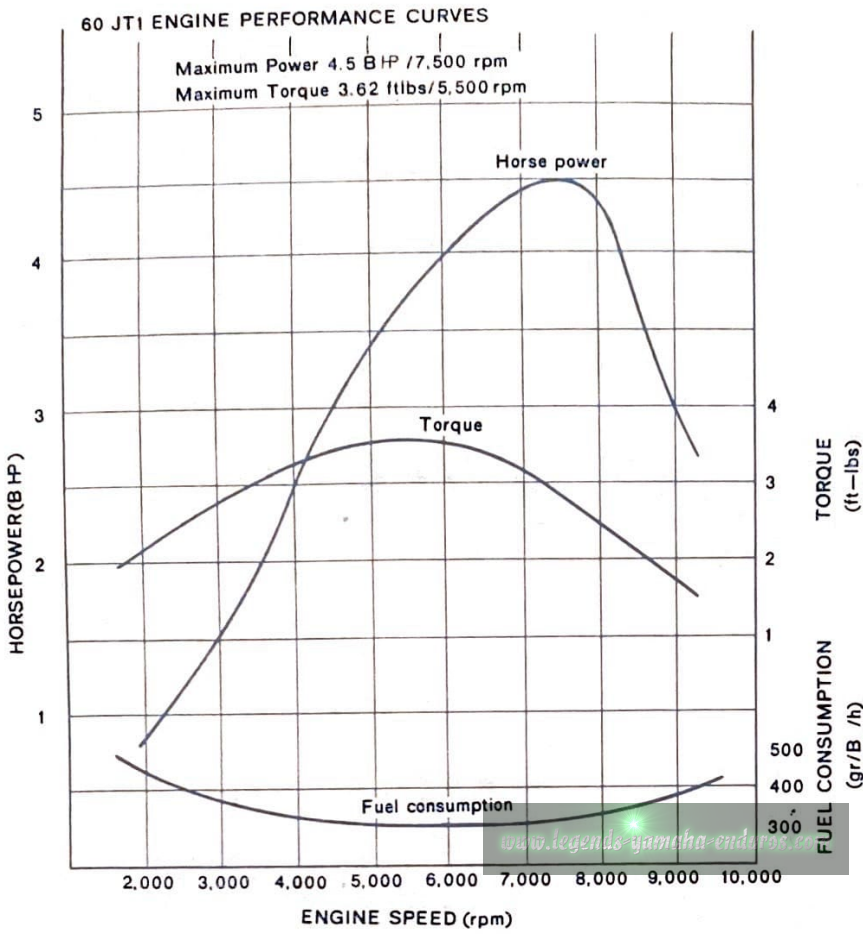

3-port Cylinder Exploded View

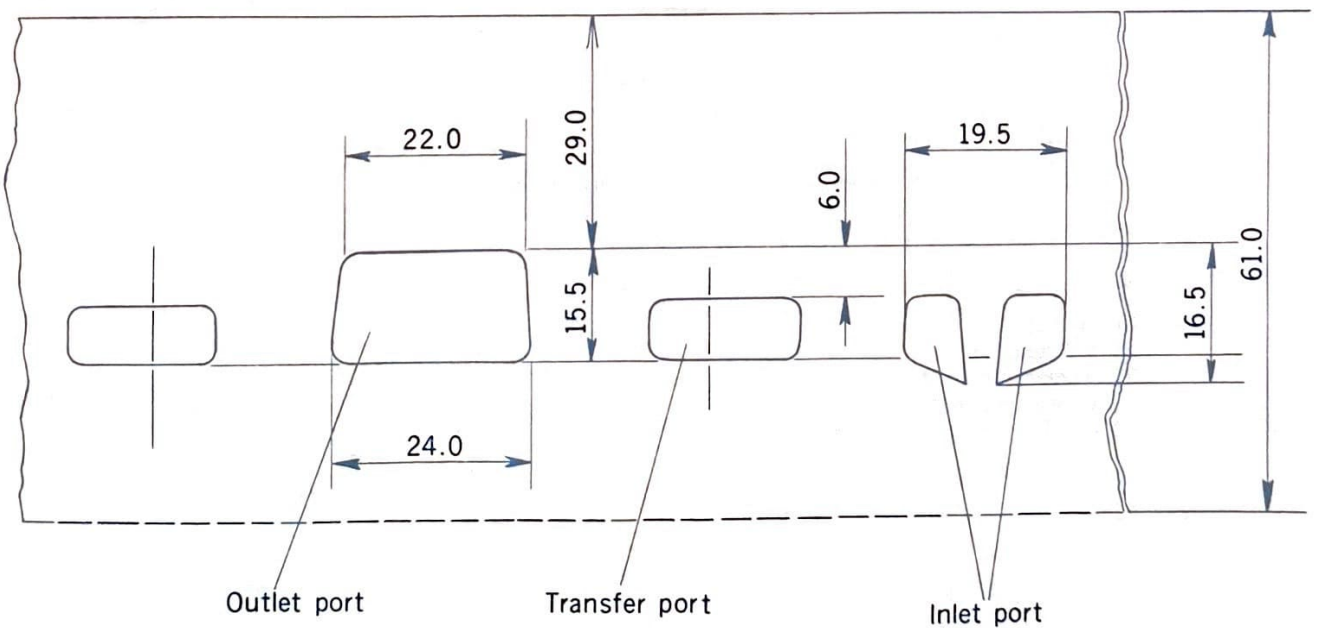

1-6 Tools and Instruments for Shop Service

The following tools and instruments are required to service the JT1

1 General Tools

- 1) Plug wrench 23x29 mm.
- 2) A set of wrenches
- 3) A set of socket wrenches
- 4) Plastic tip hammer
- 5) Steel hammer
- 6) Circlip pliers (ST type)
- 7) Circlip pliers (RT type)
- 8) Needle nose pliers
- 9) Pliers
- 10) Phillips-head screwdriver
- 11) Phillips-head screwdriver (L)
- 12) Philips-head screwdriver (M)
- 13) Philips-head screwdriver (S)
- 14) Slot-head screwdriver (M)
- 15) Slot-head screwdriver (S)
- 16) T-handle socket wrench

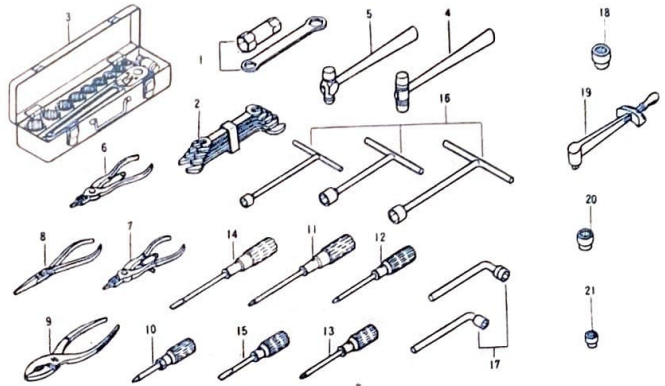

Fig 1-6-1

2 Special Tools and Instruments

- 1) Clutch holding tool
- 2) Crankcase disassembling tool
- 3) Crankshaft assembling tool
- 4) Flywheel magneto holding tool
- 5) Flywheel magneto puller

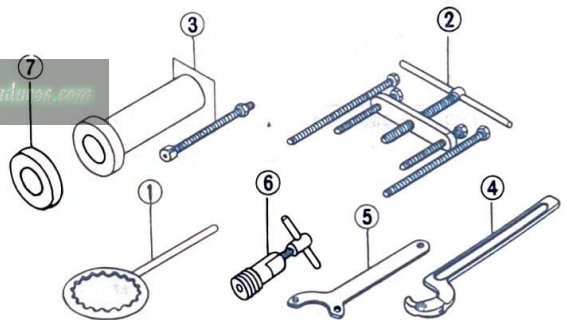

Fig 1-6-2

In addition, an electro-testor, tachometer (engine rpm meter) hydrometer, etc. should and available.

3 Other Material

- 1) Grease
- 2) Autolube oil
- 3) Yamaha Bond (No.2)
- 4) Wiping material
- 5) Overhauling stand (Wooden box)
- 6) Parts tray
- 7) Oiler
- 8) Oil jug

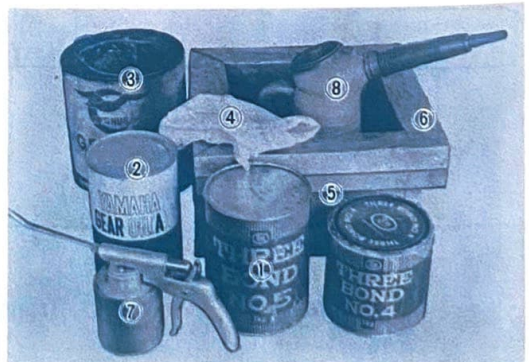

Fig 1-6-3

The use of a wooden box as shown in the above photo will facilitate engine service and overhaul. Consumable parts (such as gaskets) and replacement parts must also be on hand.

CHAPTER 2 YAMAHA AUTOLUBE (Automatic, Separate Lubrication System)

2-1 What is Yamaha Autolube?

Conventional 2-stroke engines are lubricated by oil pre-mixed in gasoline, but YAMAHA's Autolube furnishes an automatic, separate lubrication system. That is, the oil in a separate oil tank is automatically regulated by the oil pump and fed to the engine according to engine speed and load.

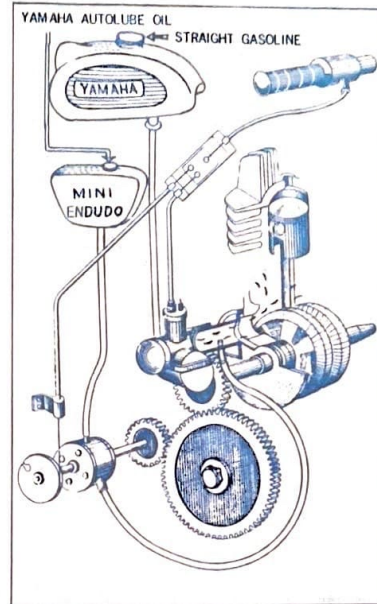

Fig 2-1-1

2-2 Features of Yamaha Autolube www.legends-yamaha-enduros.com

The oil pump is driven by the engine through a reduction gear and is connected to the carburetor throttle cable, which in turn is controlled by the accelerator grip. The oil pump automatically regulates the volume of lubricating oil according to engine speed and throttle valve opening, thus pumping the optimum amount of oil for engine lubrication under any operating condition.

This "automatic, separate lubrication" does not merely eliminate disadvantages in the conventional pre-mix system, but it further improves the performance and efficiency of 2-stroke designs by eliminating certain oil-starvation conditions which formerly existed.

- 1 The Autolube feeds an optimum amount of lubricating oil to the engine under any operating condition, thus featuring:
 - * Less oil consumption.
 - * Less carbon accumulation.
 - * Less exhaust smoke.
 - * Improved lubricating efficiency.
- 2 The Autolube simplifies fuel supply, thus featuring:
 - * Using straight gasoline directly in the gas tank.
 - * Less fuel contamination.
- 3 The Autolube improves the reliability of lubrication, thus eliminating:
 - * Special care concerning oil/fuel mixing ratios.

2-3. Handling the Oil Pump

The oil pump is a precision-machined assembly. Make no attempt to disassemble it. When you remove the oil pump from the engine, protect it from dust, dirt, etc., and after reinstalling it, bleed and adjust the pump correctly. Proper handling will keep the pump free from trouble.

The oil pump is similar in both construction and operation to other Autolube systems. The only difference is the employment of a 4.0 ϕ plunger because of larger consumption of oil by a 60 c.c. single cylinder engine.

2-3-1 Checking Minimum Pump Stroke

1 Checking

- a Fully close the accelerator grip.
- b Turn the oil pump starter plate in the direction of the arrow marked on the plate. Then measure the gap between the adjustment pulley and the adjustment plate. Keep the gap as wide as possible by observing it with the eye prior to measuring.
- c. Insert a feeler gauge (0.15 mm) into the gap.
When the gap allows it to enter
.....Stroke is correct.
When the gap does not allow
.....Stroke is insufficient.

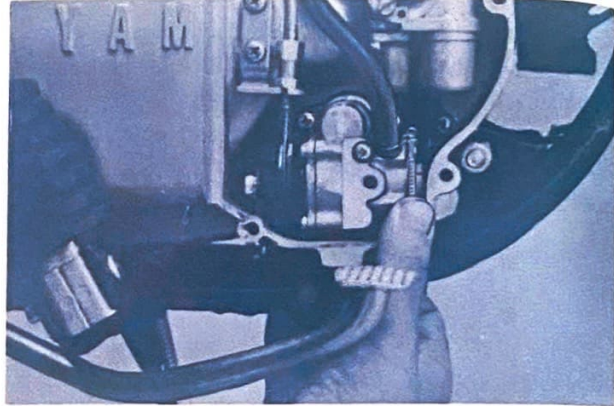

Fig. 2-3-1

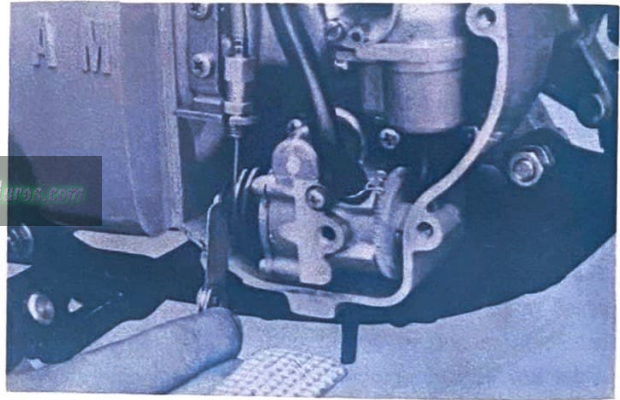

Fig 2-3-2

2 Adjustment

- a Remove the adjustment plate lock nut, and then remove the adjustment plate.

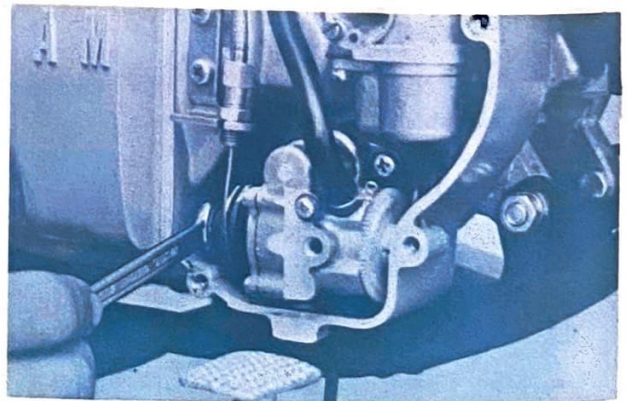

Fig 2-3-3

- b Install a 0.1 mm. adjustment shim where the adjustment plate was.
- c Reinstall the adjustment plate lock nut, and measure minimum stroke. When the gap allows a 0.20 mm feeler gauge to enter but does not allow a 0.25 mm, the stroke is correctly adjusted.

Stroke adjustment tolerance....0.20 to 0.25 mm.

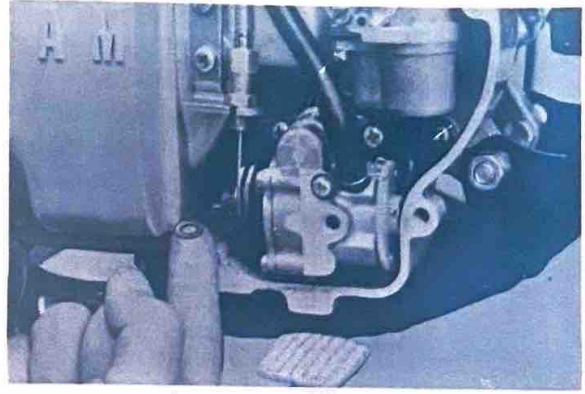

Fig 2-3-4

2-3-2 Carburetor and Autolube Cable Adjustment

Follow the preceding in section 2-3-1 steps to check minimum stroke, and adjust it if incorrect. Then adjust the pump and carburetor as described in the steps below.

1) Throttle Cable Adjustment

- a Adjust the carburetor with the engine at idle, and remove all but 1 mm of slack from cable B.
- To bring the play of the throttle cable into correct adjustment, loosen or tighten the throttle cable adjustment screw.
- To check this adjustment, lightly pull throttle cable B, and engine speed should slightly increase from idling r.p.m.

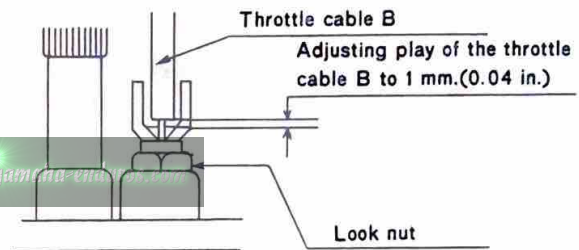

Fig 2-3-5

- b Next, adjust throttle cable(A) so that the gap as shown in Fig.2-3-6 below will be between 0.5 and 1.0 mm, (0.02~0.04 in.)
- Check the play of the throttle cable (A) by pulling on the outer part of the throttle cable. If the play is excessive or insufficient, adjust the play with the adjustment screw.

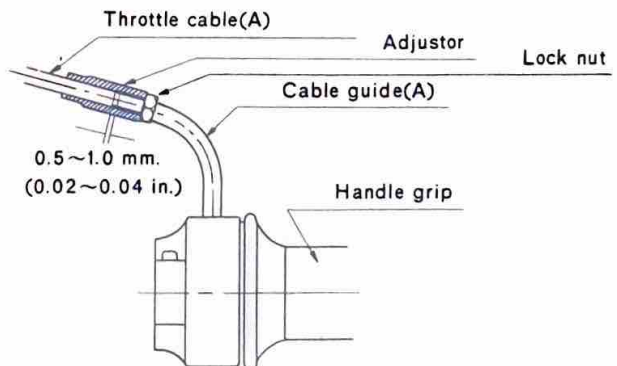

Fig 2-3-6

2) Autolube Cable Adjustment

- a Adjust the pump cable so that the marking (arrow) on the Autolube pump adjustment pulley is aligned with the guide pin (see Fig.2-3-8). Begin by fully closing the accelerator grip, then slowly turning it back again so that the slack in the throttle cable is completely taken up. Next, adjust the pump cable so that the mark-

ing on the pump adjustment pulley will be aligned with the guide pin, as shown in Fig. 2-3-7. The point of adjustment is at the end of the cable, just before it enters the case. Loosen the lock nut and screw the adjuster in or out, whichever direction is necessary to obtain the correct adjustment.

- b. Next, check the location of the pin at full throttle. It should not strike the raised boss at the end of the pump

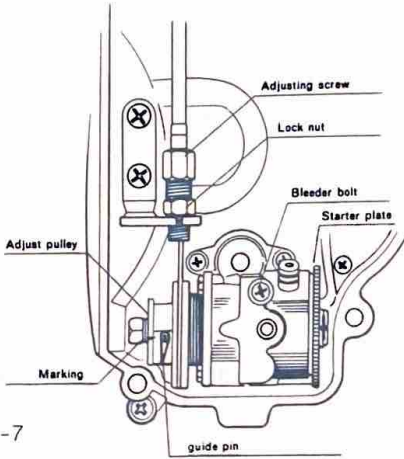

Fig 2-3-7

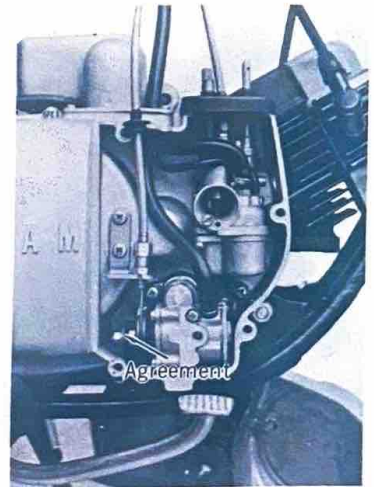

Fig 2-3-8

2-3-3 Bleeding

When the pump has been removed or the Autolube oil has run out, air will enter the pump. The air will cause an irregular flow of oil after the pump is mounted again or the oil tank is refilled. In order to prevent such an irregular flow of oil, bleed the pump in the following manner.

- 1) Remove the bleeder bolt.

www.legends-yamaha-enduros.com

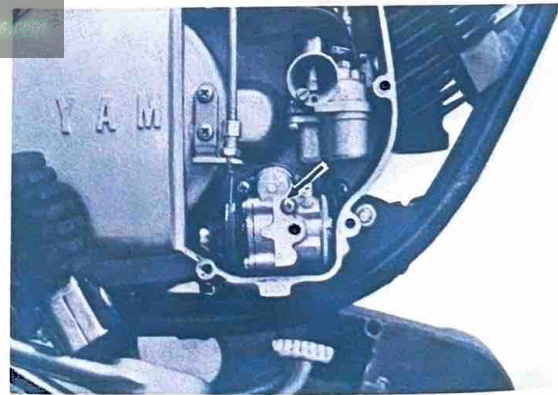

Fig 2-3-9

- 2) Next, rotate the starter plate in the direction of the arrow marked on the plate. Continue turning the plate until no air comes out with the oil and tighten the bleeder bolt. To facilitate this bleeding, fully open the accelerator grip and rotate the starter plate. As the plunger stroke becomes greater, the air can be quickly bled.

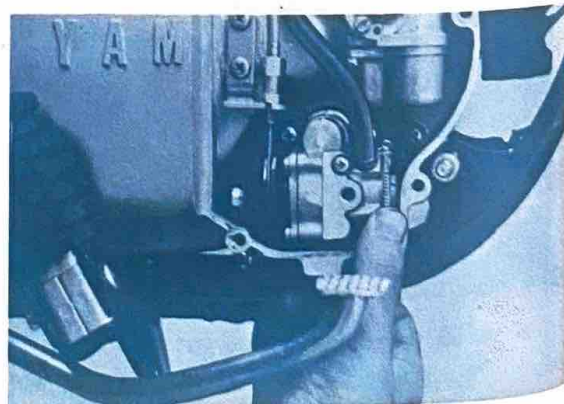

Fig 2-3-10

CHAPTER 3 ENGINE

This chapter describes the disassembly and reassembly of the engine, its removal from the chassis, and the necessary service data. However, except when overhauling the crankshaft assembly, transmission, shifter mechanism, or bearings and oil seals in the crankcase, it is suggested that engine be serviced without removing it from the chassis. This will save a lot of time and labor.

Preparation for disassembly of the engine :

- 1) All dirt, mud, dust, and foreign material should be thoroughly removed from the exterior of the engine assembly before removal and disassembly. This will prevent any harmful foreign material from entering the interior of the engine assembly.
- 2) Before engine removal and disassembly, be sure you have proper tools and cleaning equipment so you can perform a clean and efficient job.
- 3) During disassembly of the engine, clean all parts and place them in trays in order of disassembly. This will make assembly time faster and easier, and insure correct installation of all engine parts.

3-1 Engine Removal

- 1 Start the engine and warm it up for a few minutes, then turn off the engine and drain the transmission oil

(Volume of oil : 600 cc(0.64USqt)

(SAE 10W/30)

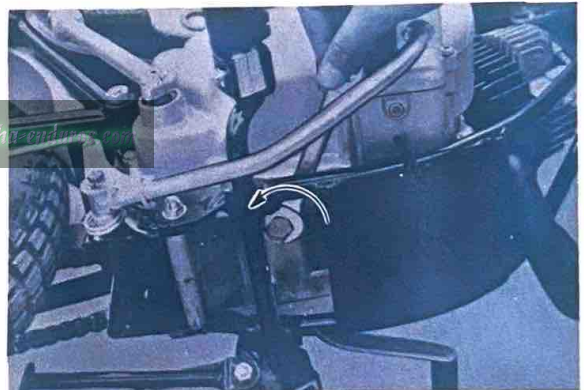

Fig 3-1-1

- 2 Pull out the seat fitting pin and remove the seat by pulling it backward.

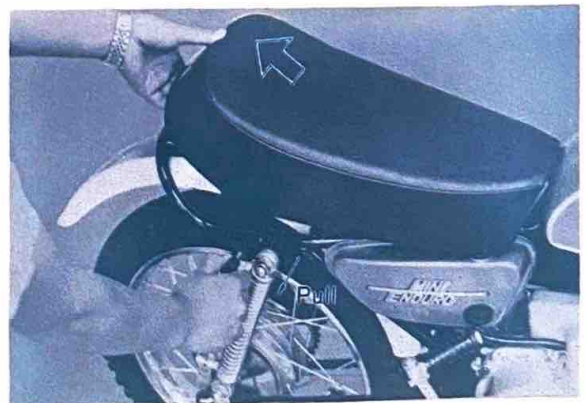

Fig 3-1-2

ENGINE - Engine Removal

- 3 Disconnect the fuel line at the bottom of the fuel tank. Remove the tank mounting bolt (13 mm)

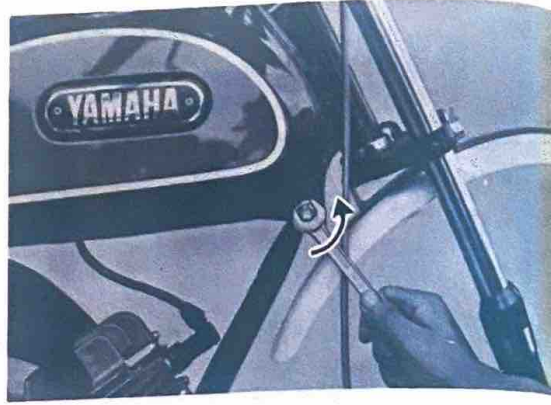
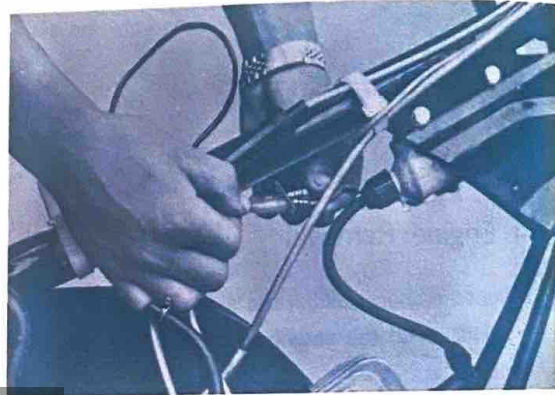

Fig 3-1-3

- 4 Remove the connector from the magneto lead wire and remove the plug cap.



www.legends-yamaha-enduro.com Fig 3-1-4

- 5 Remove the muffler
 - a) Remove the exhaust pipe nut.

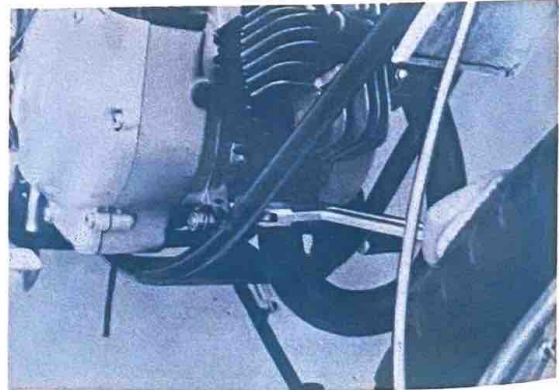

Fig 3-1-5

- b) Remove the muffler holding bolts (13 mm)

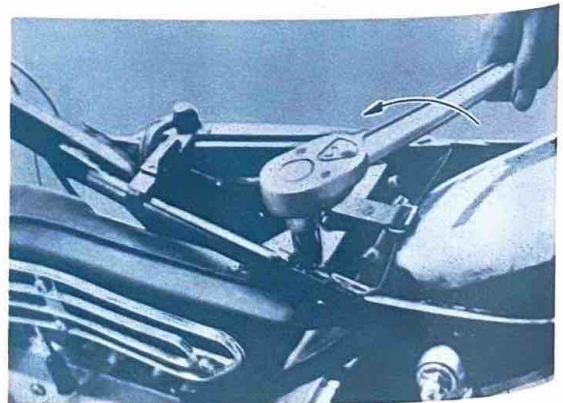

Fig 3-1-6

- 6 Remove the change pedal
(10 mm)

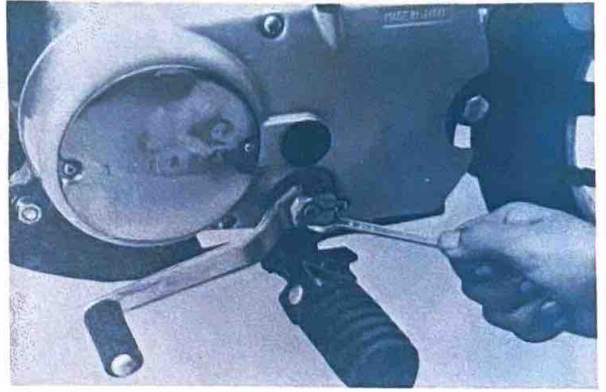

Fig 3-1-7

- 7 Remove the lefthand crankcase cover
(⊕ screwdriver)

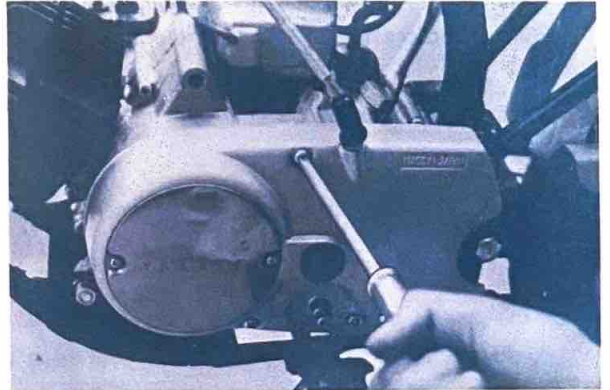

Fig 3-1-8

- 8 Disconnect the master link and remove the chain.

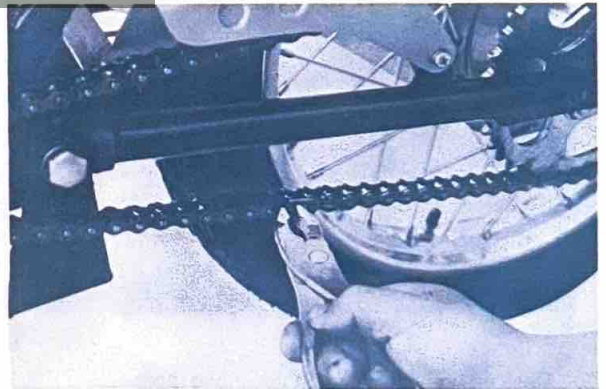
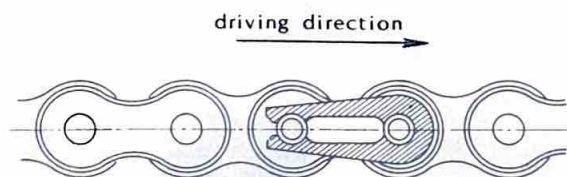

Fig 3-1-9

When reconnecting the chain be sure the master link is facing in the correct direction.



After reconnecting the chain adjust the free play to 25 mm. (1 in.) up and down at the center of the lower section with the rear wheel on the ground.

ENGINE - Engine Removal

- 9 Remove the pump cover and pump cable
(⊕ screwdriver)

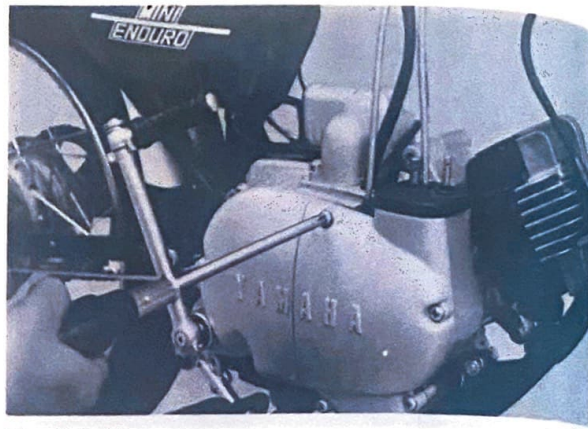

Fig 3-1-10

- 10 Remove the oil pipe and plug the hole with a bolt to stop the flow of oil from the tank

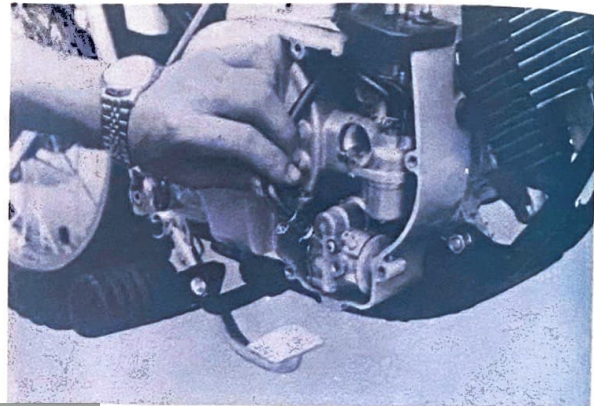

Fig 3-1-11

- 11 Remove the fuel pipe and remove the carburetor.
(⊖ screwdriver)

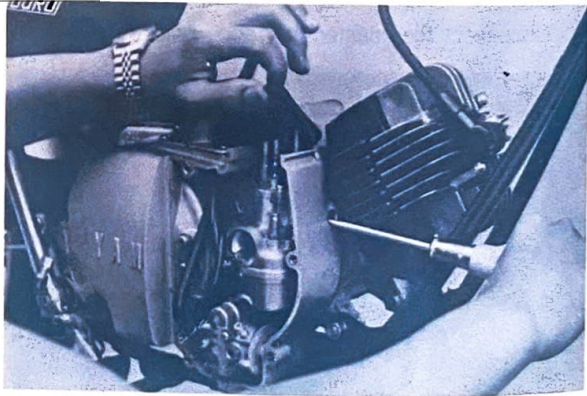

Fig 3-1-12

- 12 Remove the four engine mounting bolts
(13 mm)

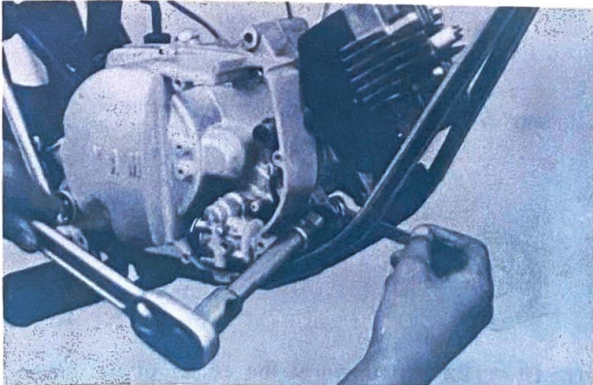

Fig 3-1-13

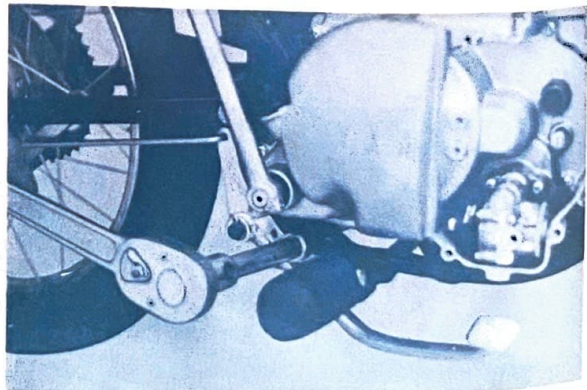

Fig 3-1-14

13 Remove the engine from the frame.

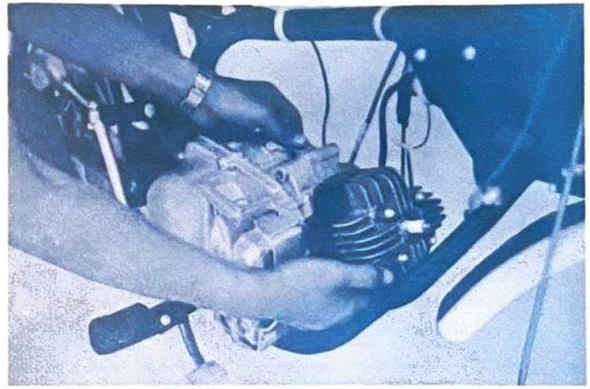

Fig 3-1-15

3-2 Cylinder Head

The cylinder head is bolted on the cylinder with special nuts.

A Removing

Remove the four special nuts from the top of the cylinder head, then the head and head gasket. Reverse the sequence for reinstallation. Replace the gasket, if damaged. gsd.

(10 mm)

Note: During reassembly the head bolts must be torqued to 90 in/lbs in pattern, and in successive stages. Do not torque a hot engine and for most accurate readings place a small amount of light weight oil on the threads first.

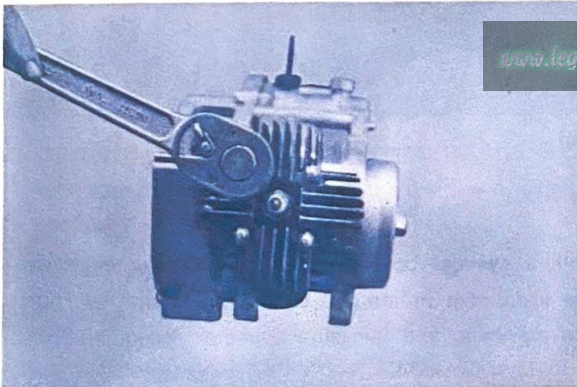

Fig 3-2-1

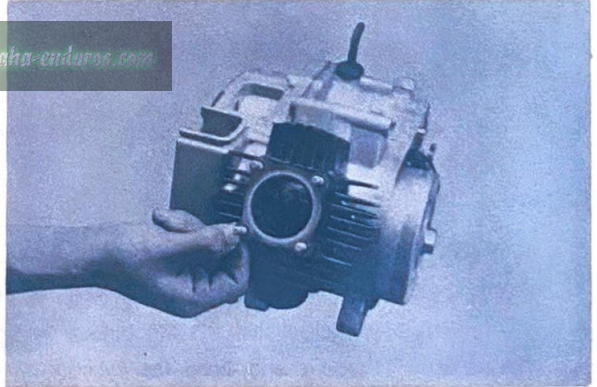

Fig 3-2-2

B Removing Carbon Deposits

Carbon deposits on the cylinder head combustion chamber and top of the piston will result in an increase in the compression ratio, as well as pre-ignition and engine overheating.

Scrape the cylinder head and piston dome clean.

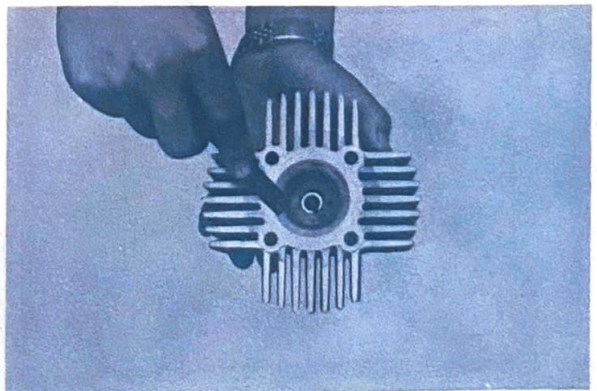

Fig 3-2-3

3-3 Cylinder

- A 1) Remove the cylinder by striking it lightly with a soft faced hammer

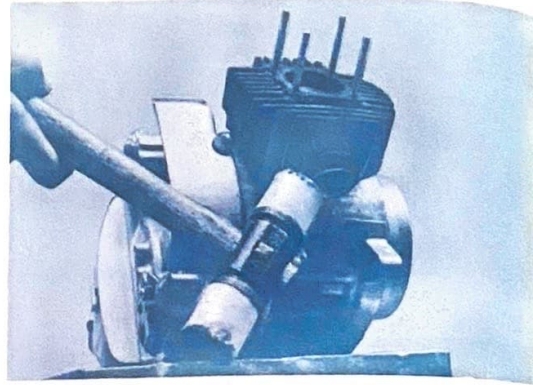

Fig 3-3-1

- 2) Always replace the cylinder base gasket when reassembling.

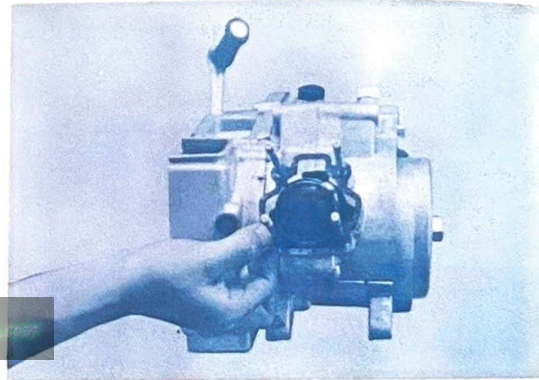
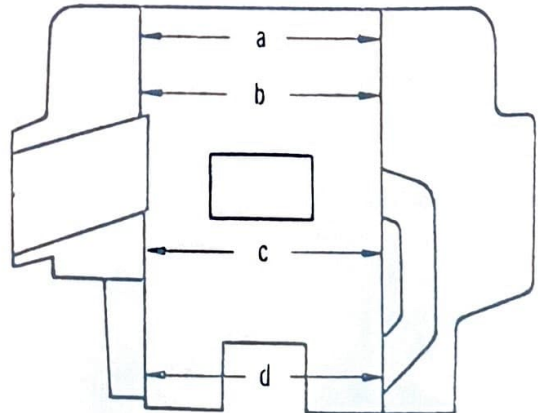
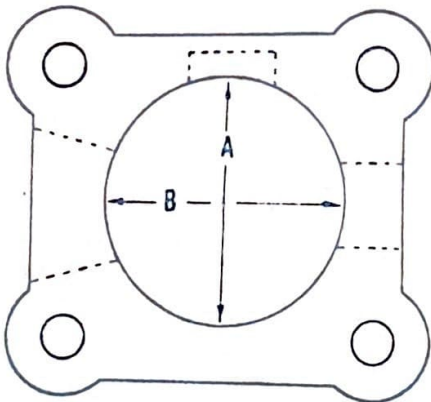

Fig 3-3-2

www.legenda-yamaha-enduros.com

B Checking the Cylinder for Wear

- 1) Measure the amount of wear of the cylinder wall with a cylinder bore measuring micrometer or cylinder gauge (Measure it at four depths while positioning the instrument in line and then the piston at right angles to the crankshaft.) If the difference between the maximum and minimum diameter exceeds 0.05 mm (0.0019") rebore and hone the cylinder.



- 2) The piston clearance between the piston and the cylinder is 0.040-0.045 mm 0.0016" - 0.0018"

C Cylinder Reconditioning

- 1) Pistons are available in 0.25 and 0.50 mm. (0.010" and 0.020") oversizes.
- 2) The cylinder should be rebored and honed to the diameter of the oversize piston plus the minimum allowable clearance.
- 3) The error between the maximum and minimum diameters after honing should be no more than 0.04 mm. (0.0015")

D Removing Carbon Deposits

Scrape off the carbon accumulation in the exhaust port of the cylinder with the dulled end of a hack-saw blade.

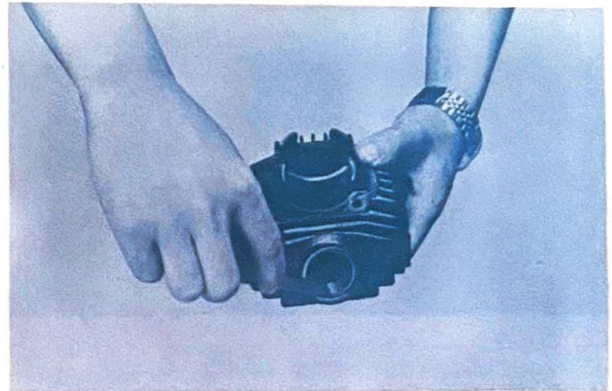

Fig 3-3-3

E Installing the Cylinder

Put your fingers at each end of the piston ring, expand the ring, and slip it onto the piston. Align both ends of the ring with the knock pin in each ring groove. Next, insert the piston into the cylinder. Take care not to damage the bottom of the cylinder with the rings.

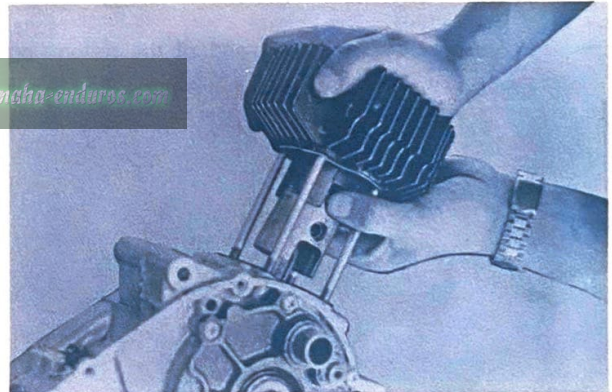

Fig 3-3-4

3-4 Piston Pin

A Pulling out the Piston Pin

Remove the clips at both ends of the piston pin with needle nose pliers, and press out the piston pin with a finger or a slot-head screw driver.

Note : Before removing the piston pin clips, cover the crankcase with a clean rag, so you will not accidentally drop the clip or other foreign particles into the crankcase.

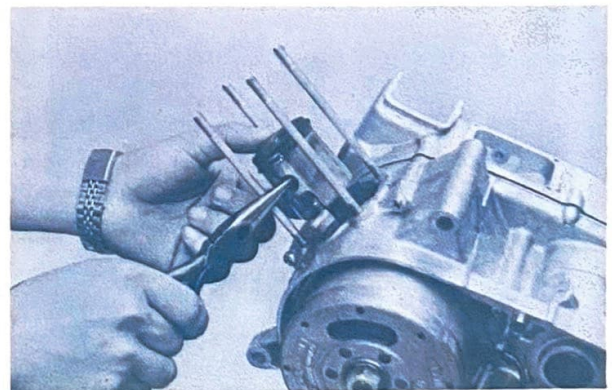

Fig 3-4-1

B Piston-to-Piston pin fit

The piston pin should fit snugly in its bore so that it drags a little as you turn it. If the piston pin is loose, replace the pin and/or the piston.

If the pin has step-wear in its center, replace the needle bearing as well as the piston pin. Check the small end of the connecting rod for wear by inserting the piston pin and bearing.



Fig 3-4-2

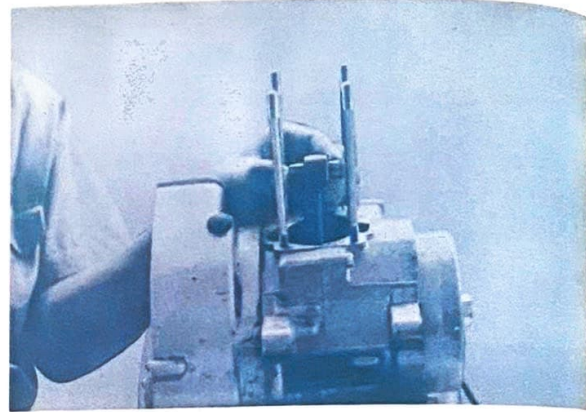

Fig 3-4-3

3-5 Piston Ring

A Removing the Piston Rings

Put your thumbs at each end of the piston ring and pull the piston ring ends apart. Remove the ring by moving the ring off the piston on the other side of the ring ends.



Fig 3-5-1



Fig 3-5-2

B Installing the Piston Rings

First fit No.2 ring over the piston, and then the No.1 ring, and align their end gaps with the locating pin in each ring groove. (Fig. 3-5-3)

The printing on all rings must face up to position the gap properly at the pin.

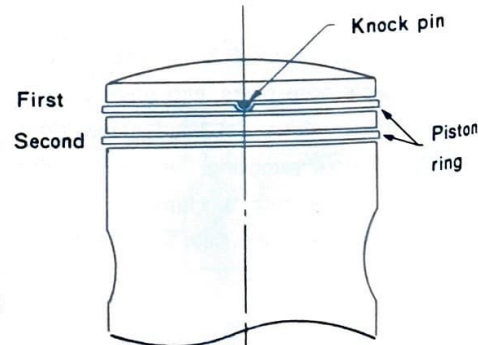

Fig 3-5-3

C. Checking the Piston Rings

- 1) Measuring piston ring wear Put the ring into the cylinder so that the ring is parallel to the cylinder bottom edge, and then measure the end gap with a feeler gauge (Fig. 3-5-4) The end gap should be between 0.15 and 0.35 mm (0.006"-0.014") for both No.1 and No.2 rings

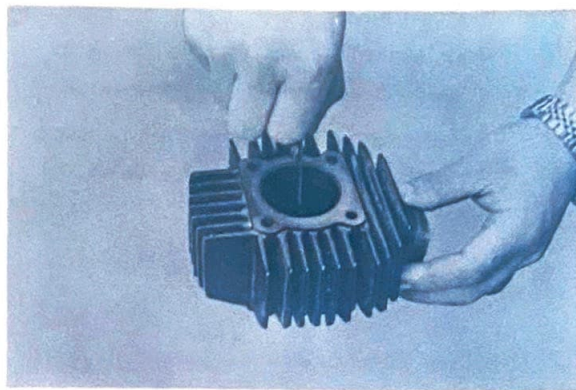

Fig. 3-5-4

- 2) Removing carbon

Carbon on the piston rings and in the ring grooves will make the rings stick in the piston, thus causing gas blow -by.

Remove the rings from the piston, and clean the carbon from the rings and ring grooves.

3-6 Piston

The piston is made of a high-silicon aluminum alloy.

A Checking and Correcting the Piston to Cylinder Wall Clearance

- 1) Measuring piston clearance
Piston clearance is the difference between the minimum cylinder bore diameter and the maximum outside diameter of the piston. As described in 4-3 Cylinder, piston clearance should be 0.040-0.045mm (0.0016-0.0018") To determine the maximum piston diameter, measure the piston with a micrometer at right angles to the skirt 10 mm. (3/8 in.) from its bottom edge. (Fig. 3-6-1)

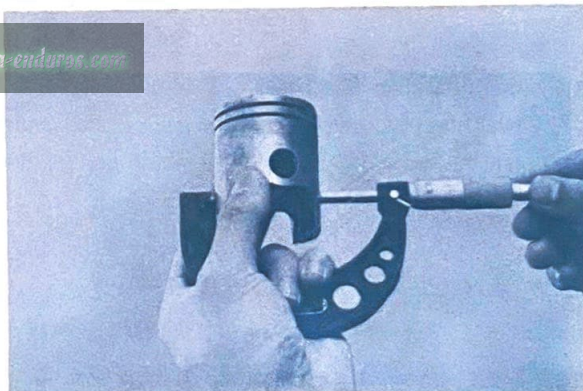

Fig. 3-6-1

- 2) Checking and correcting scratches on the piston

A piston showing signs of seizure will result in noise and loss of engine power. It will also cause damage to the cylinder wall.

If a piston that has seized is used again without correction, another seizure will develop in the same area. Lightly sand the seizure "high spot" on the piston with wet #400 and paper until smooth.



Fig. 3-6-2

3) Removing Carbon

Remove carbon accumulations on the piston head, using a screwdriver or a saw-blade.

Note Whenever carbon accumulations are removed, take care that the under lying metal is not scored or otherwise damaged.



Fig 3-6-3

Carbon and gum accumulations in the piston ring grooves will result in piston ring seizure. Remove them from the ring groove.



Fig 3-6-4

B Piston Installation Direction

Install the piston with the arrow mark on the head pointing forward (toward the exhaust port of the cylinder)

www.legends-yamaha-enduros.com

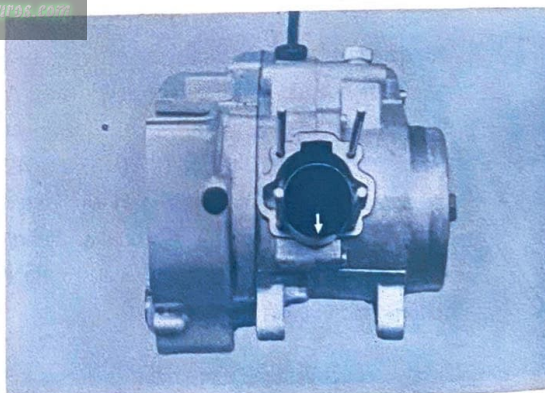

Fig 3-6-5

3-7 Flywheel Magneto

A. Remove the nut using a flywheel magneto holding tool.

(19 mm)

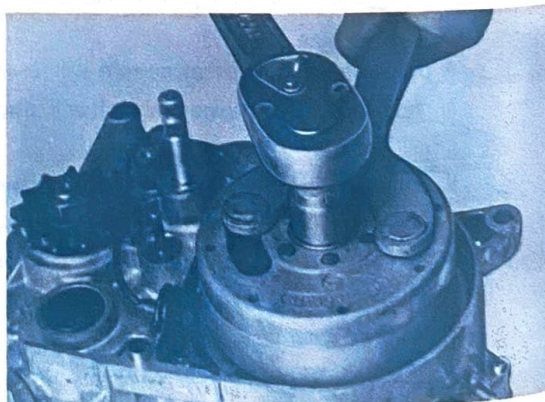

Fig 3-7-1

- B Install the flywheel magneto puller
Then tighten the bolt the flywheel magneto will
break loose (left-hand thread)
(Nut: 17 mm)

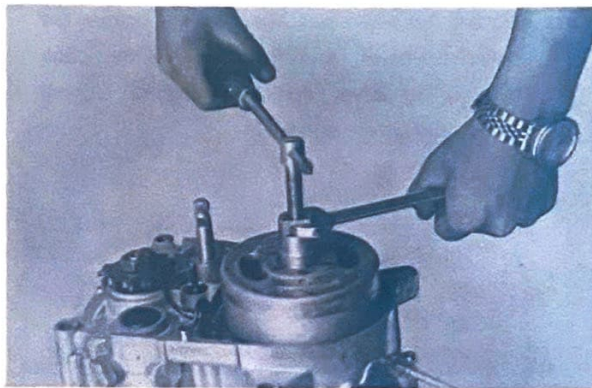

Fig 3-7-2

- C Remove the two screws holding the flywheel magneto base to the crankcase, and remove the flywheel magneto base

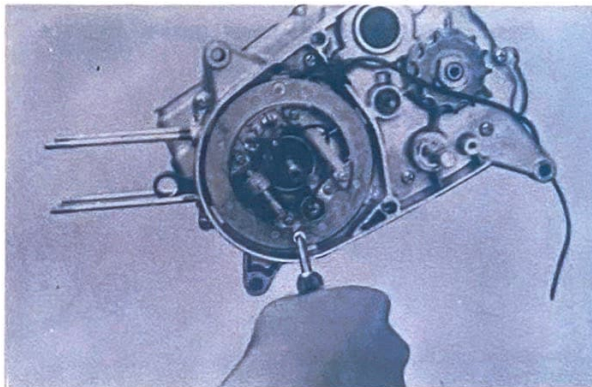

Fig 3-7-3

- D Remove the woodruff key.
It is advisable to place the woodruff key on the flywheel magnets (using its magnetic force) while the key is removed for engine service. This will keep it from becoming lost

(⊖ Screw driver, hammer)

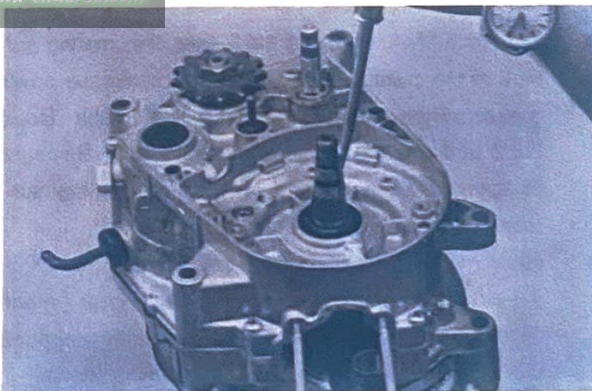

Fig. 3-7-4

3-8 Crankcase Cover (R. H.)

A Removal

- 1) Remove the kick crank mounting bolt and the crank.

(10 mm)

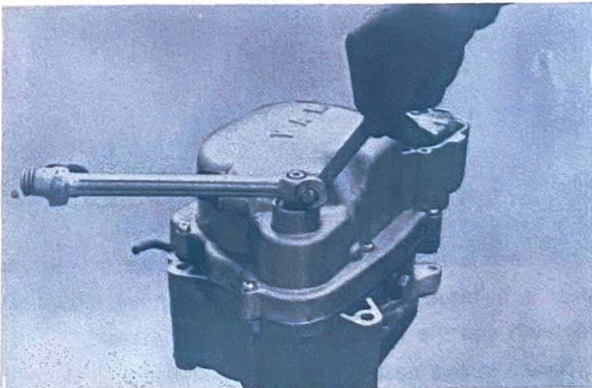

Fig 3-8-1

- 2) Remove the seven pan head screws holding the crankcase cover, and then remove the case cover. (The cover can be removed without taking off the oil pump)

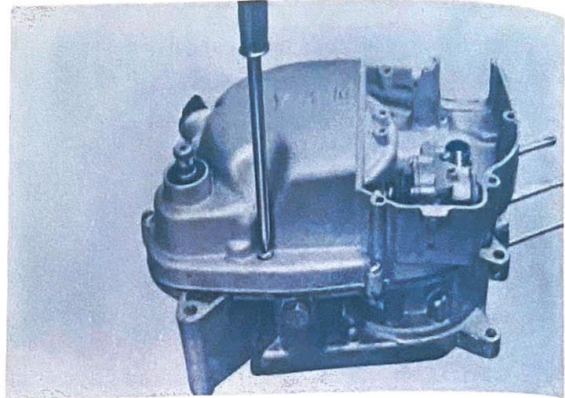
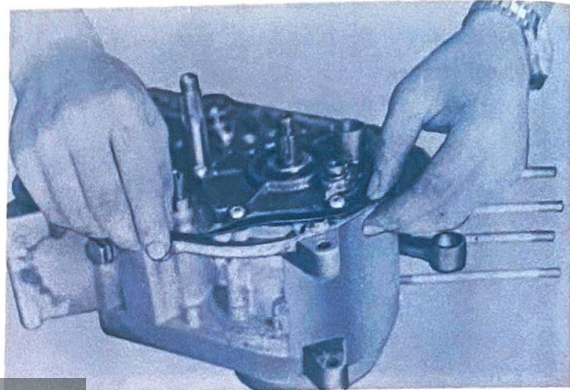

Fig 3-8-2

- 3) Remove the crankcase cover gasket. Replace it, if damaged.



B Installation

www.legends-yamaha.com Fig 3-8-3

Spread YAMAHA Bond No.2 over the mating surface of the crankcase R. Place the crankcase cover gasket on the crankcase and apply Yamaha Bond No.2 and replace the crankcase cover R. Be sure to apply YAMAHA Bond No.2 to the mating surface; otherwise the crankcase will leak.

Note: When installing the crankcase cover (R), make sure that the pump drive gear (made from synthetic resin) is correctly engaged with the primary drive gear. In addition, make certain that all mating surfaces have been thoroughly cleaned.

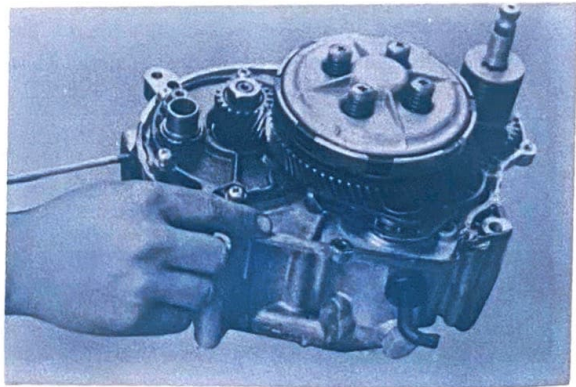

Fig 3-8-4

3-9 Clutch

The clutch is of the wet disc type, consisting of two molded cork friction plates and one steel clutch plate. It is installed on the transmission main shaft.

The clutch housing forms a one piece assembly with the primary gear of the primary reduction system, and the reduction gear is in mesh with the pinion. The primary reduction ratio is $74/19$ (3.894), because the primary drive gear has 19 teeth and the primary driven gear 74/teeth.

(Note: In this case, be sure to pull out the Autolube pump banjo bolt.)

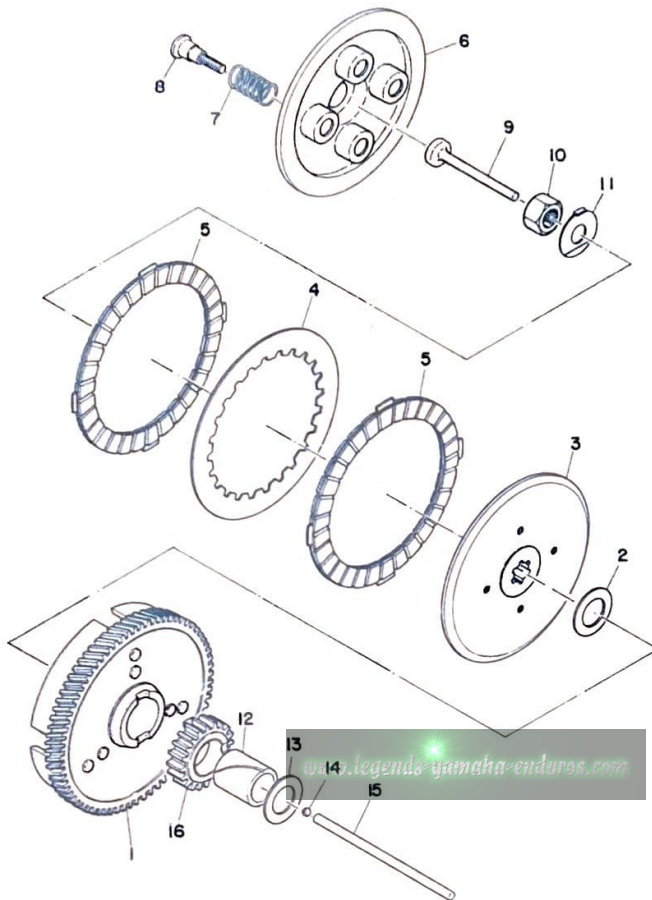

1. Primary driven gear ass'y
2. Thrust plate
3. Clutch boss
4. Clutch plate
5. Friction plate
6. Pressure plate
7. Clutch spring
8. Spring screw
9. Push rod 1
10. Lock nut
11. Lock washer
12. Spacer
13. Thrust plate
14. Ball
15. Push rod 2
16. Kick pinion gear

Fig 3-9-1 Clutch ass'y exploded view

A. Removing the Pressure Plate

Remove the four clutch spring holding screws, and take out the pressure plate and push crown.

(⊖ Screwdriver)

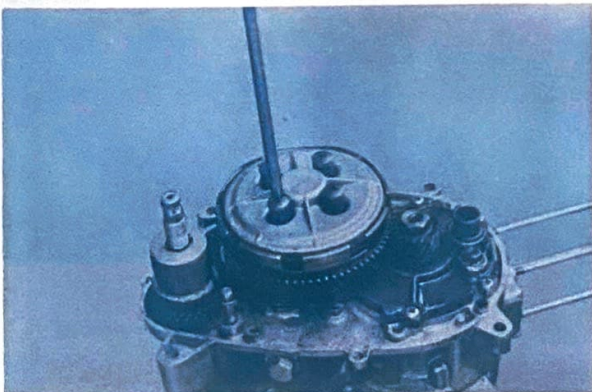

Fig. 3-9-2

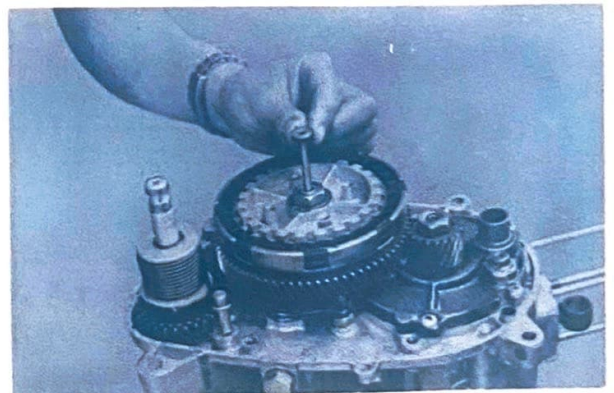

Fig. 3-9-3

B. Removing the Clutch Boss

Install the clutch holding tool on the clutch boss.
Loosen the lock nut, and then remove the clutch boss.
(19 mm)

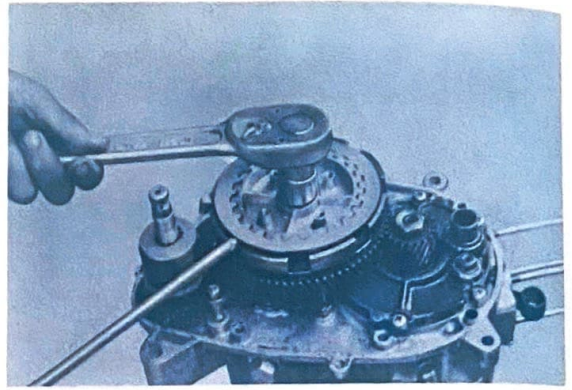

Fig. 3-9-4

C. Checking the Clutch Spring

If the free length of the spring is 1 mm (0.04 in.) or more shorter than the standard free length, replace it.
(Slide calipers)

Free length 34 mm (1.340 in.)

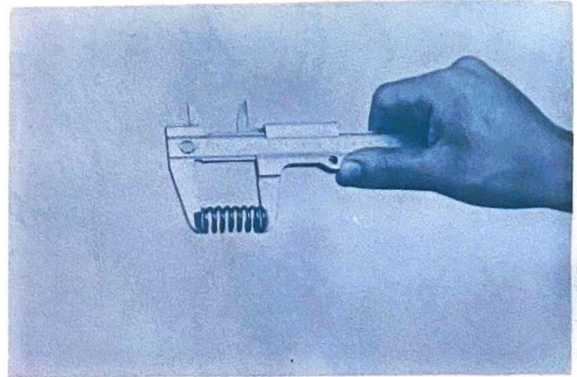

Fig. 3-9-5

D. Checking the Friction Plates

Inspect the friction plate for wear. Replace it if it shows 0.35 mm (0.0137 in.) or more uneven contact.

(Slide calipers)

Standard thickness 3.5 mm (0.137 in.)

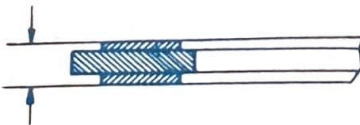

Fig. 3-9-6

E. Clutch Housing Assembly

(integrated with the primary driven gear.)

1) Inspection

Insert the primary gear retaining collar (spacer) in the primary driven gear boss and check it for radial play. If the play is excessive (allowable clearance is between 0.009~0.048 mm.) replace the gear retaining collar because it will cause excessive noise. If any scratches are found, replace the spacer to avoid impaired clutch action.

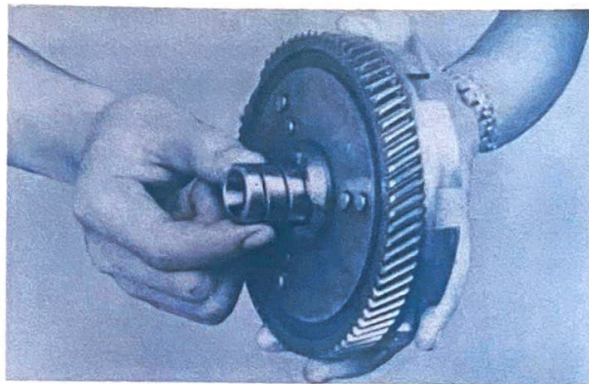
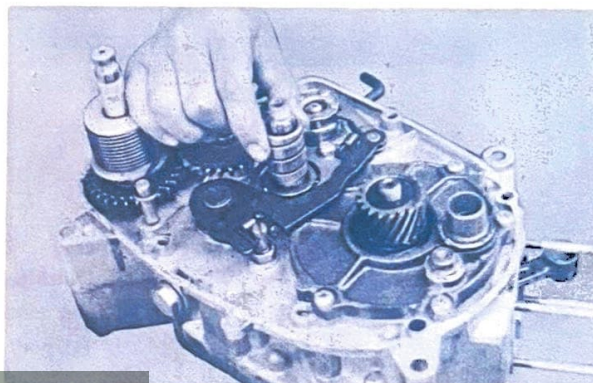

Fig 3-9-7

F. Checking the Primary Gear Retaining Collar (Spacer)

Place the primary gear retaining collar around the main axle and again check it for radial play. If play exists (allowable clearance is between 0.020~0.062 mm.) replace the gear retaining collar.

Replace any collar with step-wear on its outer surface.



www.legends-yamaha.com Fig. 3-9-8

G. Checking the Push Rod

Remove the push rod and roll it over a surface plate. If the rod is bent, or replace it.

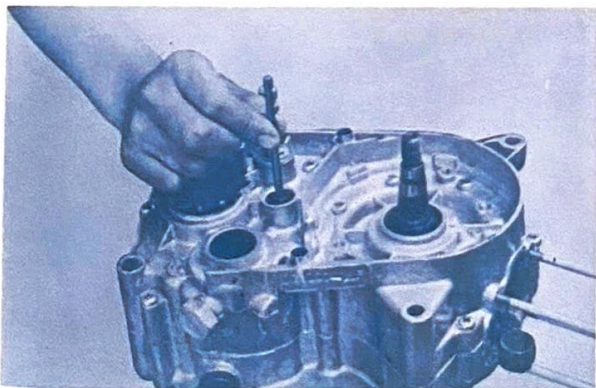

Fig. 3-9-9

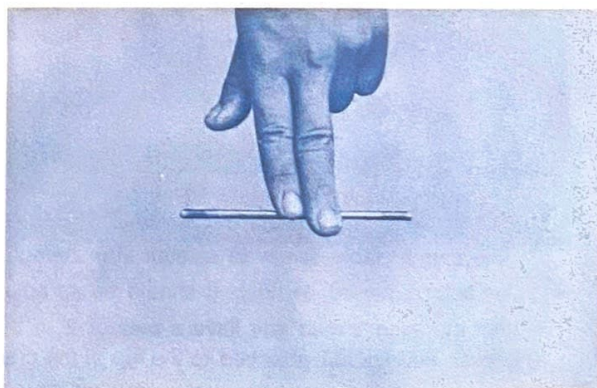

Fig. 3-9-10

H. Caution on Re-assembling the Clutch

- * On both ends of the primary gear spacer are thrust bearings. If these washers are incorrectly installed, or omitted, the clutch boss will rub directly on the primary driven gear, impairing clutch action.
- * The thrust washer fits on the primary retaining collar, but it may slip out of place when installing the clutch boss. Therefore, apply grease to both surfaces of the washer to make it stick to the gear retaining collar

Before fitting the clutch boss, install the clutch plates, friction plate etc., and then install the clutch boss

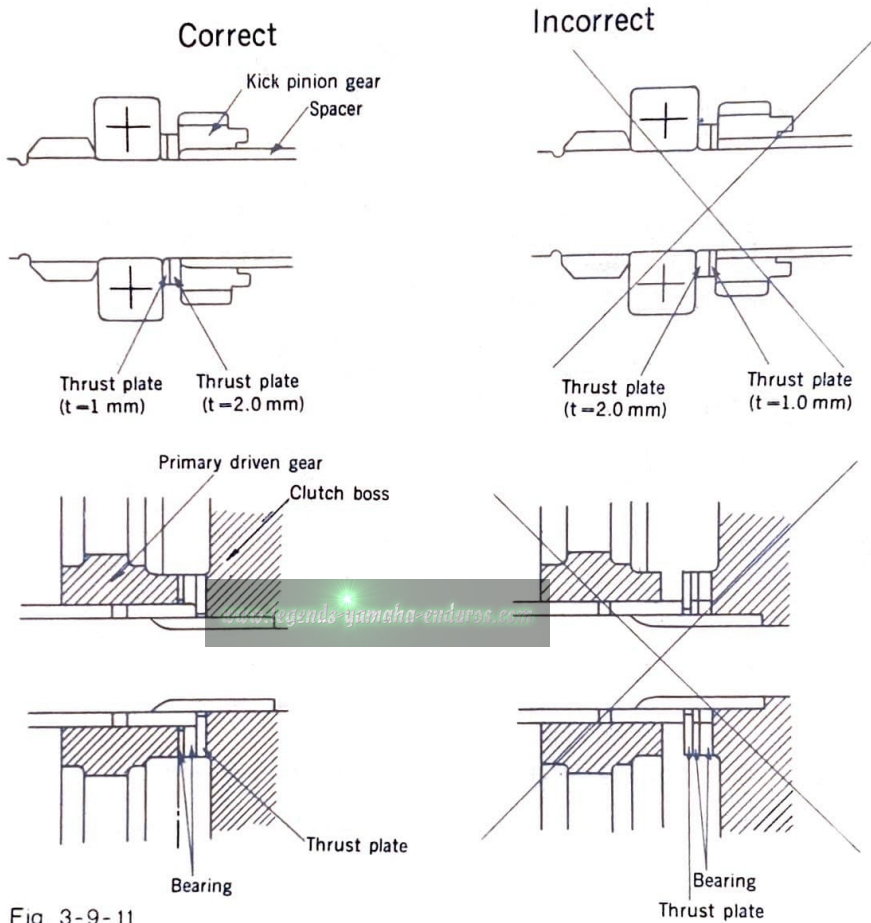

Fig 3-9-11

1 Adjusting the clutch

1. Clutch cable tension adjustment

The clutch cable tends to stretch after being used for a long period of time. It should be so-adjusted that the handle lever will have a play of 2 to 3 mm.

- a) Loosen the lock nut attached to the top of the crank-case cover(L)
- b) To reduce the play of the handle lever, loosen the adjust screw. Contrarily tightening the adjust screw makes the play of the handle lever increase.
- c) After the adjustment, be sure to tighten the lock nut.

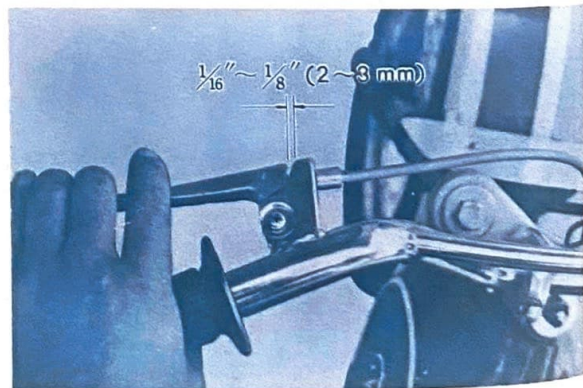

Fig 3-9-12

2) Push screw adjustment

Remove the cap and loosen the push screw lock nut located inside. Then turn in the push screw to a lightly seated position so that the push screw will have no excessive play nor be too tight. Next, back it out $\frac{1}{4}$ turn and set it with the lock nut.

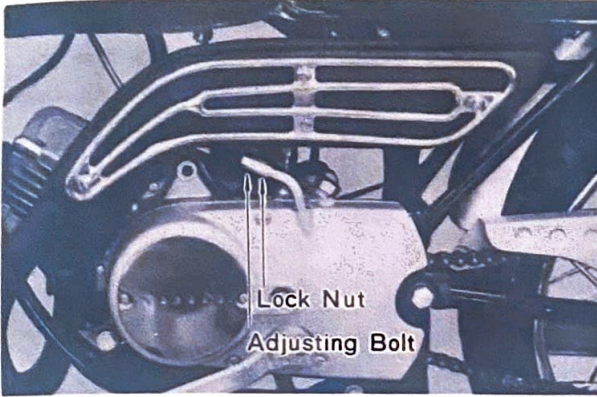

Fig. 3-9-13

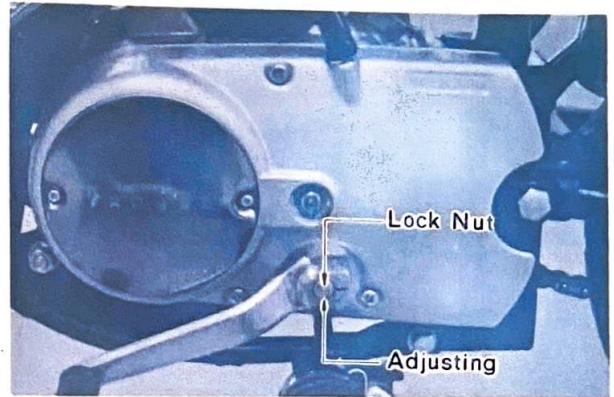

Fig. 3-9-14

3-10 Primary Drive Gear

A. Removal

Feed a rolled-up rag between the teeth of the primary drive gear and the primary driven gear to lock them, and loosen the primary drive gear lock nut. The primary gear can then be forced off by using two screwdrivers, as shown in Fig. 3-10-2.

www.legends-yamaha-enduros.com

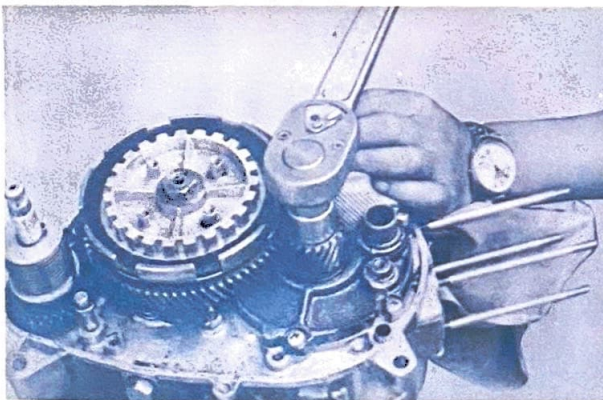

Fig. 3-10-1

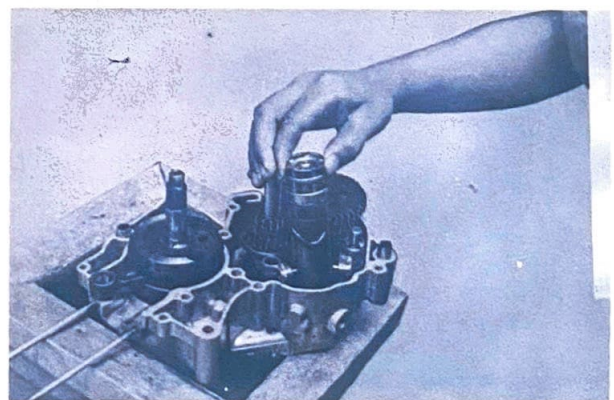

Fig. 3-10-2

3-11 Kick Starter Mechanism

The primary kick-starter system (one-touch kick-starter) is employed. However, a new "non-constant-mesh" mechanism has been introduced into the JT1 kick-starter, instead of the constant-mesh kick gear type, such as the ratchet and roller-lock systems.

That is, the kick gear meshes with the idler gear only when the kick starter pedal is kicked. After the engine has started, the kick gear and the idler gear disengage. This mechanism not only eliminates noise resulting from the constant mesh of the kick gear with the idler gear, but also greatly contributes to the durability of the kick starter assembly.

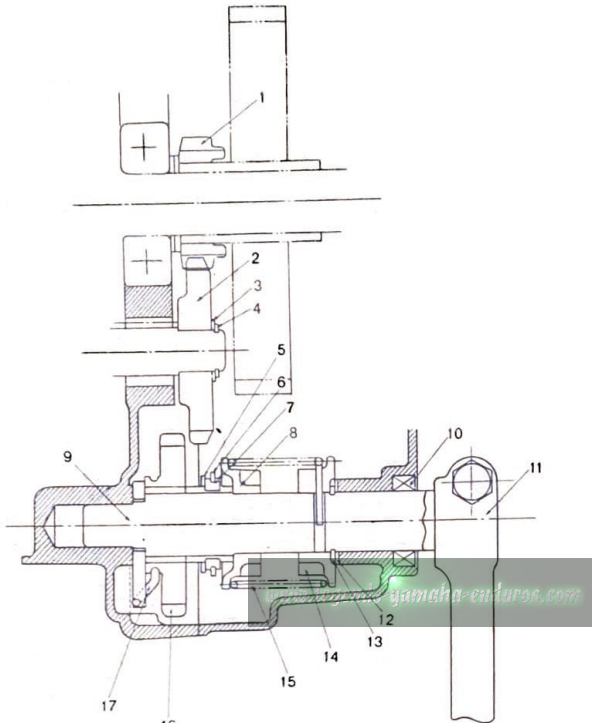

Fig 3-11-1

1. Kick pinion gear
2. Kick idle gear
3. Thrust washer
4. Circlip
5. Shim
6. Circlip
7. Kick gear holder
8. Spring guide
9. Kick axle
10. Oil seal(S-20-30-7)
11. Kick crank ass'y
12. Shim
13. Circlip
14. Spring cover
15. Kick spring
16. Kick gear
17. Kick clip

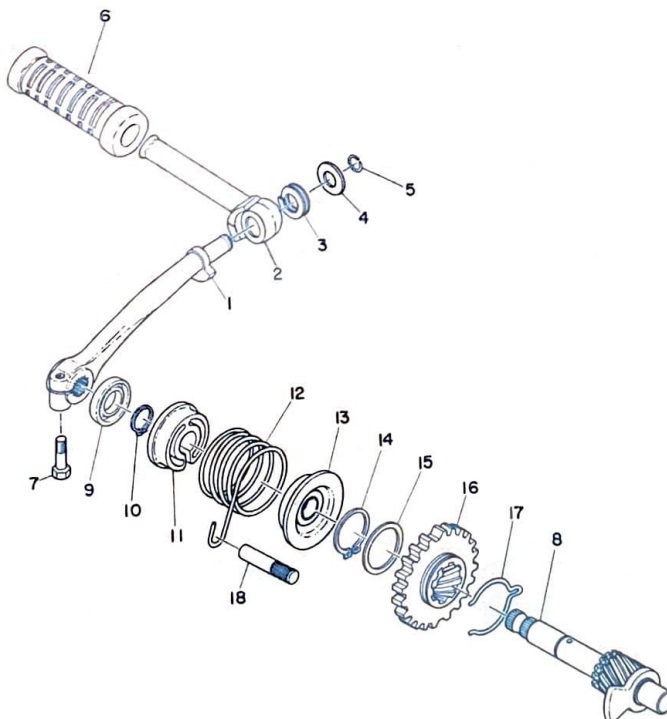

Fig 3-11-2

1. Kick crank
2. Kick lever
3. Spring
4. Washer
5. Clip
6. Kick lever cover
7. Bolt
8. Kick axle
9. Oil seal
10. Circlip
11. Spring cover
12. Kick spring
13. Spring guide
14. Circlip
15. Shim
16. Kick gear
17. Kick clip
18. Stopper

A. Removing the Kick Idler Gear

Remove the circlip with clip pliers. Then the kick idler gear can be easily removed.

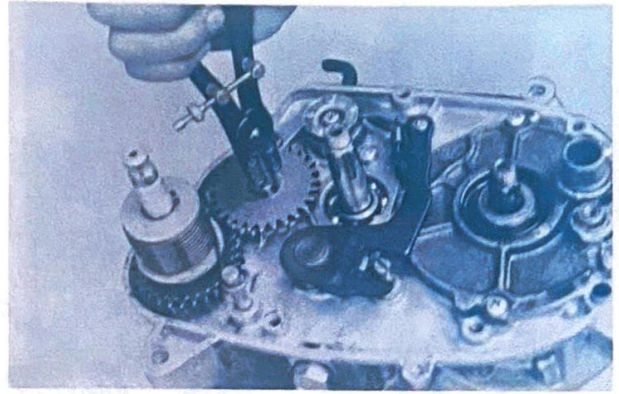

Fig. 3-11-3

b. Removal

1) Remove the kick spring.

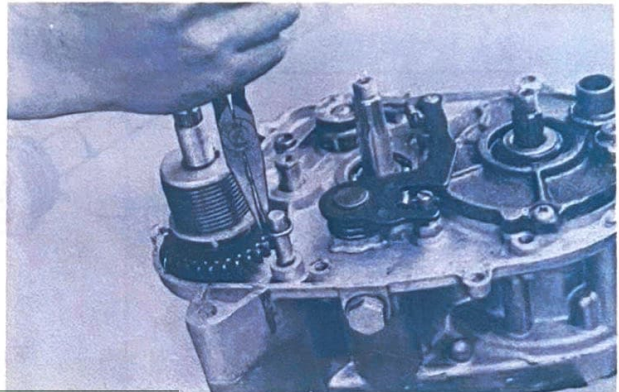

Fig. 3-11-4

2) Then remove the kick starter assembly.

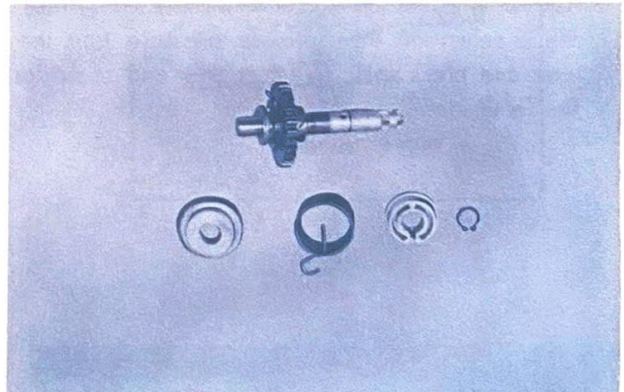

Fig. 3-11-5

3-12 Shift Mechanism

The JT1 shift mechanism is designed to select four speeds plus a position neutral position. When the change pedal is moved the gear shift arm A is moved back or forward by the gear shift arm B. The gear shift drum pin attached to the gear shift drum is pushed by the gear shift arm A, and the gear shift drum begins to rotate.

A total of five gear shift drum pins are attached to the gear shift drum. When the change pedal is moved, the unit is designed to shift through five stages. Neutral, Low, Second, Third and Top, throughout one complete turn of the gear shift drum.

The stopper plate holds the gear shift drum pin so that gear shifting can be correctly positioned at each gear position. The gear shift drum is provided with grooves on its outer surface, and the shift forks move back and forth along their respective groove grooves to change.

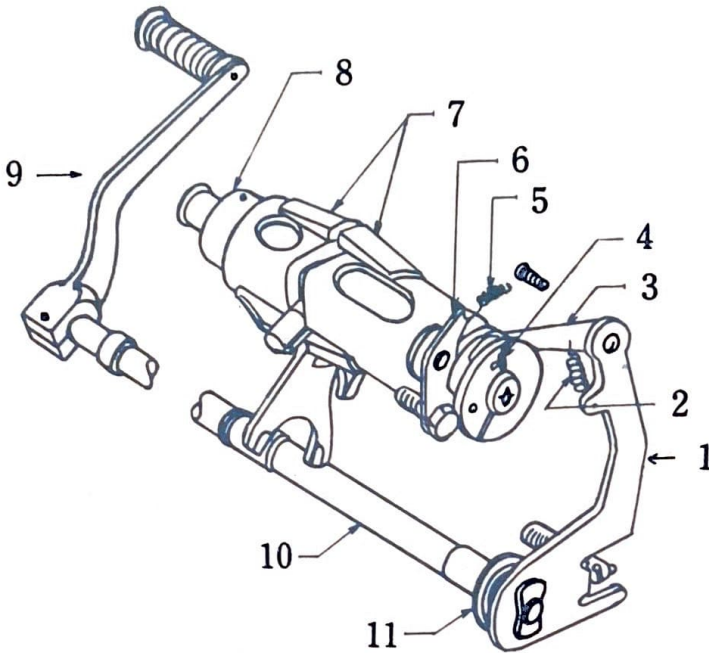

Fig. 3-12-1

A. Gear Shift Pattern

Neutral is at the top a positively selected. Press one to select low then remove pressure from the lever and press again to select 2nd. and so on for the remainder.

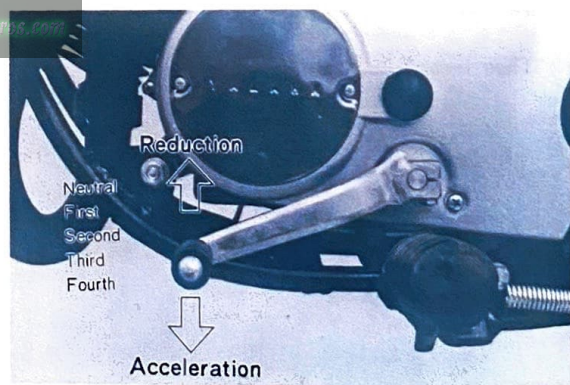

Fig. 3-12-2

A. Removing the Change Axle Assembly

1) Remove the circlip and washer from the change axle (left side crank case)

(⊖ Screw driver)

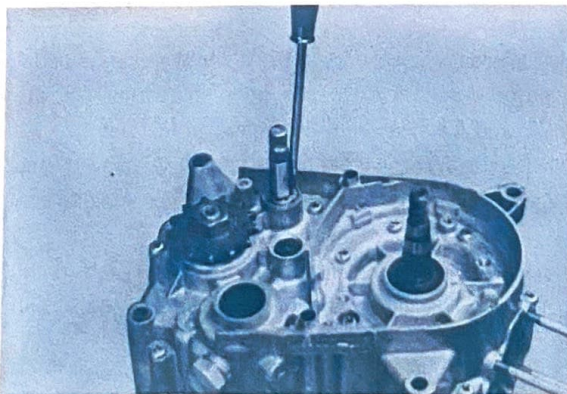

Fig. 3-12-3

2) Turn the engine over, right side up, and pull out the change shaft assembly.

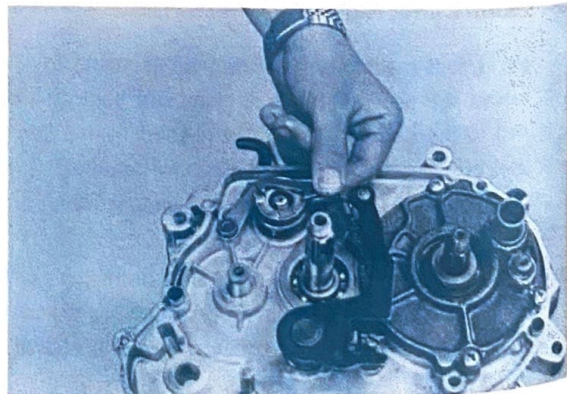

Fig. 3-12-4

B. Checking the gear shift parts (Fig. 3-12-5)

Checking the Gear Shift Return Spring. A broken or fatigued gear shift return spring will impair the return action of the shifting mechanism.

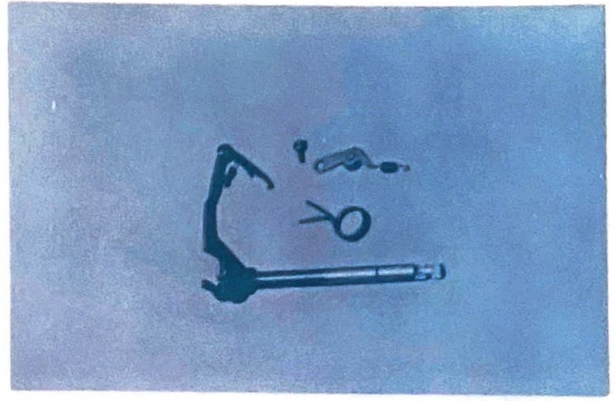

Fig. 3-12-5

C. Adjusting the gear shift arm

Adjusting or correcting the travel of the gear shift arm to prevent improper shifting progression (excess feed or insufficient feed of the gear shift arm) is accomplished by turning the gear shift return spring stop screw (eccentric bolt) in or out.

In second or third gear the measurement A—A must be equal.

(⊖ Screwdriver)

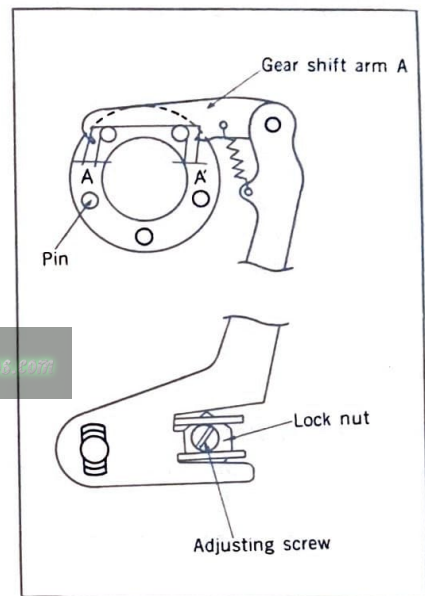

Fig. 3-12-6

3-13 Rotary Valve**A. Removal**

- 1) Remove the six valve cover set bolts and remove the valve cover.

(⊕ Screwdriver)

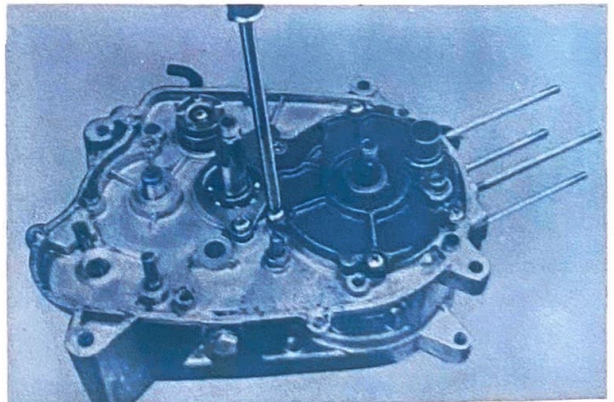

Fig. 3-13-1

2) Remove the valve and valve collar and valve distance



Fig 3-13-2

3) Remove the valve knock pin. Take care not to damage the surfaces of the crankcase.

(Nose pliers)

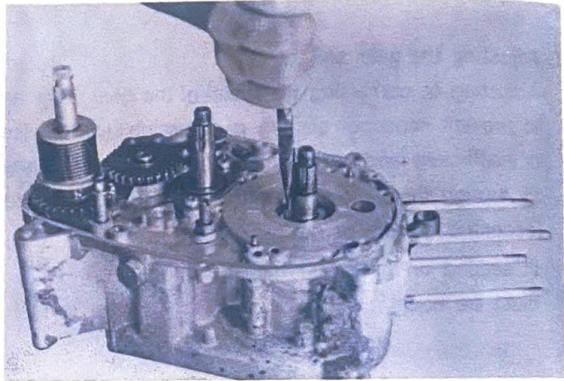

Fig 3-13-3

www.legends-yamaha-enduros.com

B. Checking the Rotary-valve.

1) Install the valve on the valve collar and check for looseness. If it is found too loose, replace it. If the collar is found to have step wear as shown in (Fig. 3-13-4) it should be replaced.

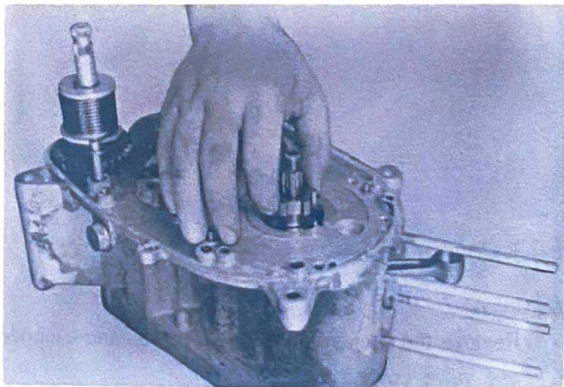

Fig. 3-13-4

2) The O-ring is liable to stretch or age after a long period of use. Any stretched or aged O-ring may fail to snugly fit in the groove. If it is found stretched slightly, it should be replaced with a new one. When installing it, grease the and fit it in the groove correctly.

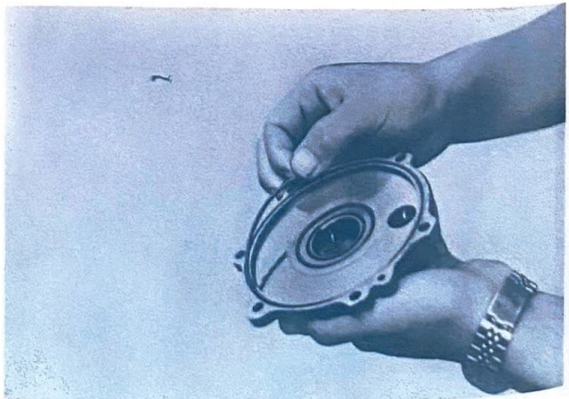

Fig 3-13-5

3) When the valve unit collar is installed, care should be taken not to scratch the crankshaft O-ring. If it is found scratched, replace it. When installing the valve unit collar, special care should be exercised so as not to scratch the O-ring. It is advisable to grease the surface of the inner collar and the outer surface of the O-ring.

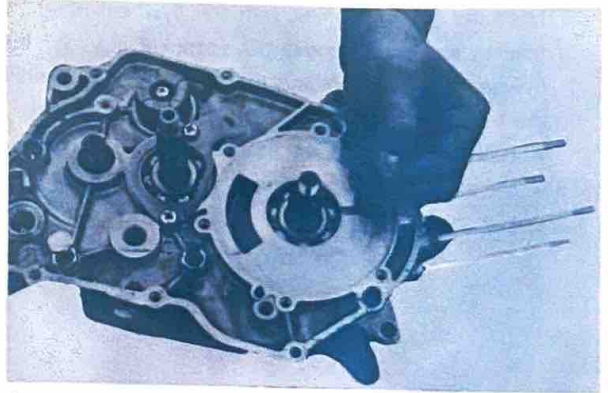
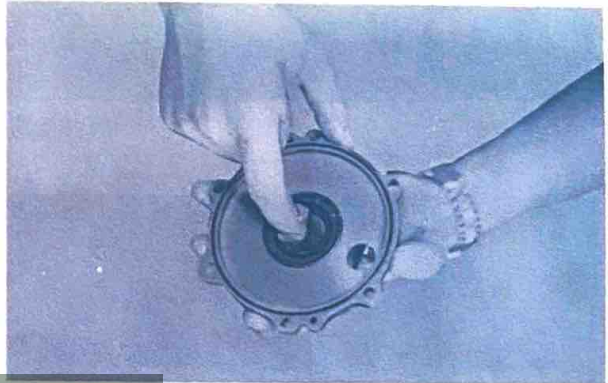

Fig 3-13-6

4) When installing the oil seal, apply good quality grease to the lip.



www.legends-yamaha.com Fig 3-13-7

3-14 Drive Sprocket

A. Removal

- 1) Straighten the bent edge of the lock washer with a blunt-ended metal punch
(Flat chisel)

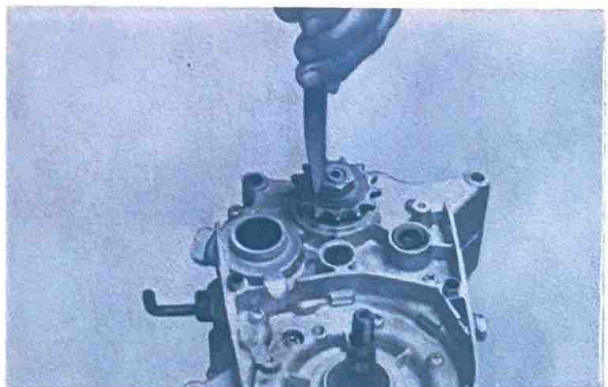

Fig 3-14-1

- 2) Hold the drive sprocket with the flywheel magneto holding tool, and remove the sprocket nut. If the flywheel magneto holding tool is not available, shift the transmission to low gear, and fit a monkey wrench on the sprocket nut. Then tap the handle of the wrench with a hammer and the shock will loosen the nut.

(21 mm)

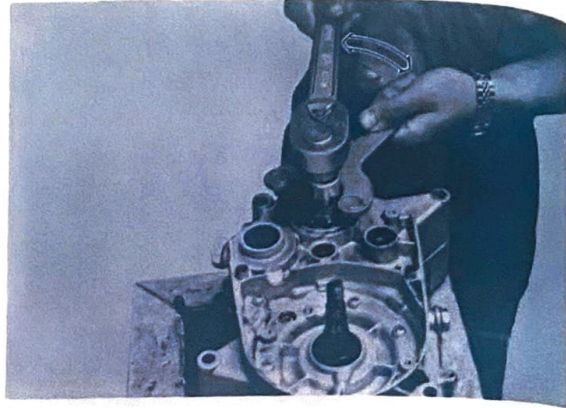

Fig. 3-14-2

- 3) Remove the distance collar with pliers. (When re-installing the distance collar, apply grease to the oil seal lip groove.)

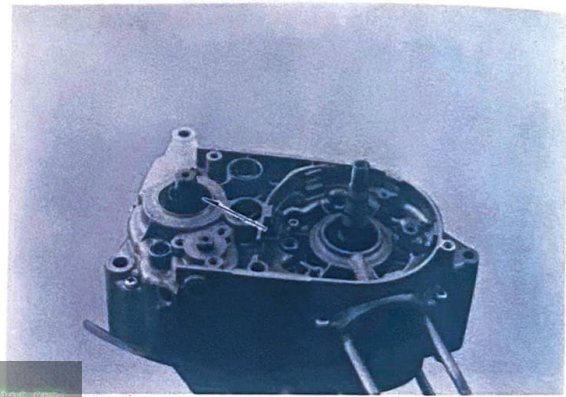

Fig. 3-14-3

B. Inspection

A worn drive sprocket will result in excessive chain noise and shorten the life of the chain. Check the sprocket for worn teeth, and replace if they are worn.

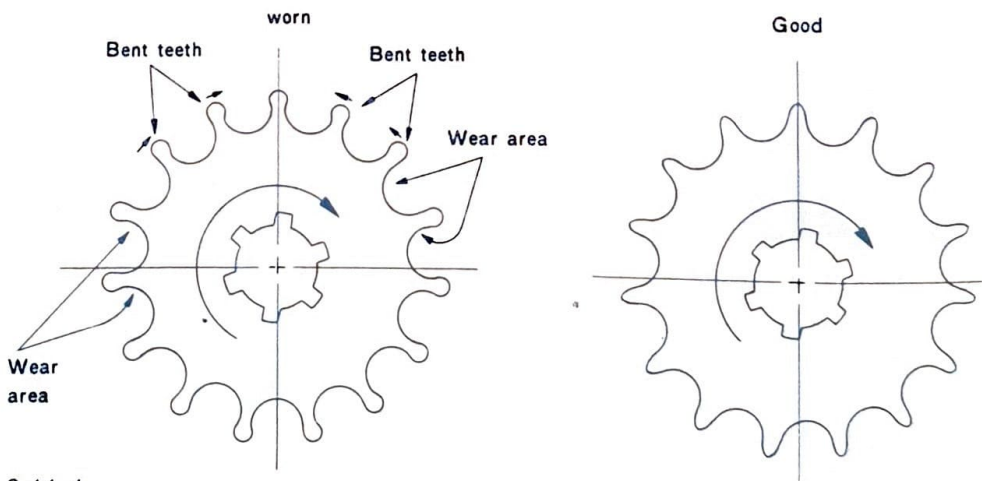

Fig. 3-14-4

3-15 Crankcase

A. Separating

- 1) Remove the neutral stopper.
(21 mm)

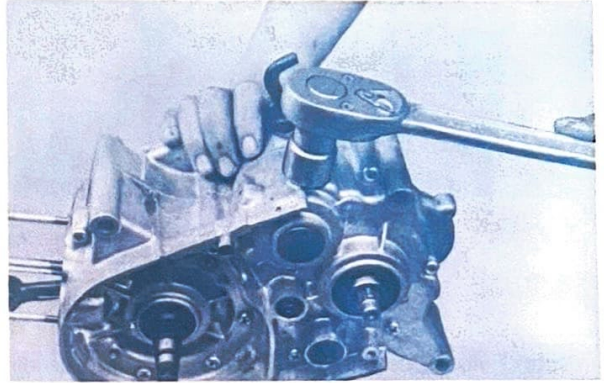

Fig 3-15-1

- 2) Remove the shift drum stopper lever and stopper spring.
(10 mm)

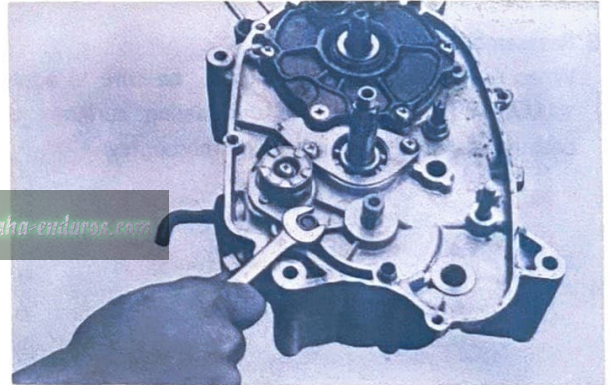

Fig 3-15-2

- 3) Remove the twelve pan head screws from the left crankcase.

(⊕ Screw driver)

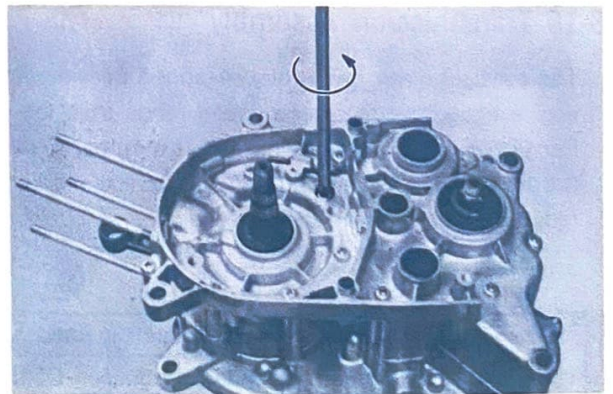

Fig 3-15-3

- 4) Install the crankcase separating tool on the right crankcase. Divide the crankcase while alternately tapping the main axle and the crankcase with a soft-faced-hammer.

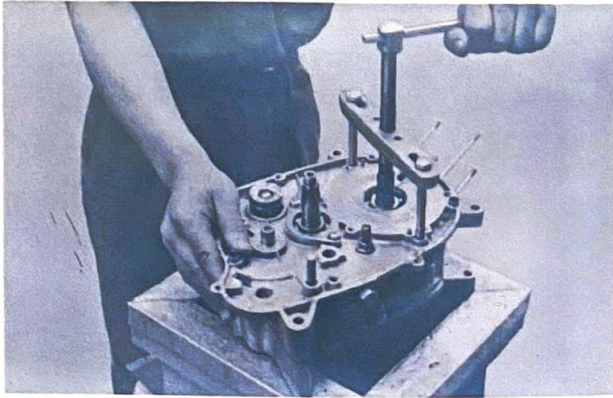

Fig 3-15-5

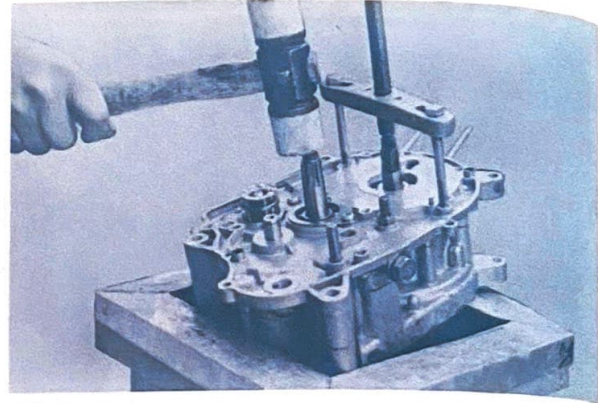

Fig 3-15-6

Note: Fully tighten the bolts of the crankcase dividing tool, keeping the tool in a horizontal position.

The crankcase is designed to split into two halves, right and left. Only one drain plug is provided for both the transmission and clutch housings. Both housings can be drained at the same time by removing the drain plug.

B. Reassembling

When reassembling the crankcase, be sure to apply YAMAHA BOND No.2 to the mating surfaces of both halves after cleaning them thoroughly

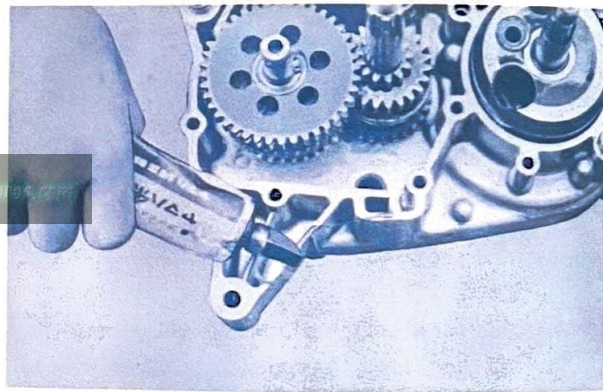

Fig 3-15-7

3-16 Transmission Assembly

The constant mesh, wide ratio, 4-speed transmission makes it possible to fully utilize the steady performance of the engine throughout the entire speed range from low to high speed.

For layout of the transmission and related parts, refer to Fig. 3-15-1 and 2. The primary reduction ratio is $74/19 = 3.894$. Therefore the total reduction ratios will be; Primary reduction ratio \times Transmission gear reduction \times Secondary reduction ratio = Total reduction ratio.

	Primary Reduction Ratio.....74/19 = 3.894	
	Secondary Reduction Ratio..... 41/13 = 3.153	
	Transmission Gear Reduction Ratio	Total Reduction Ratio
1st	40/13 = 3.077	37.773
2nd	34/18 = 1.889	23.193
3rd	30/23 = 1.304	16.010
4th	27/26 = 1.038	12.188

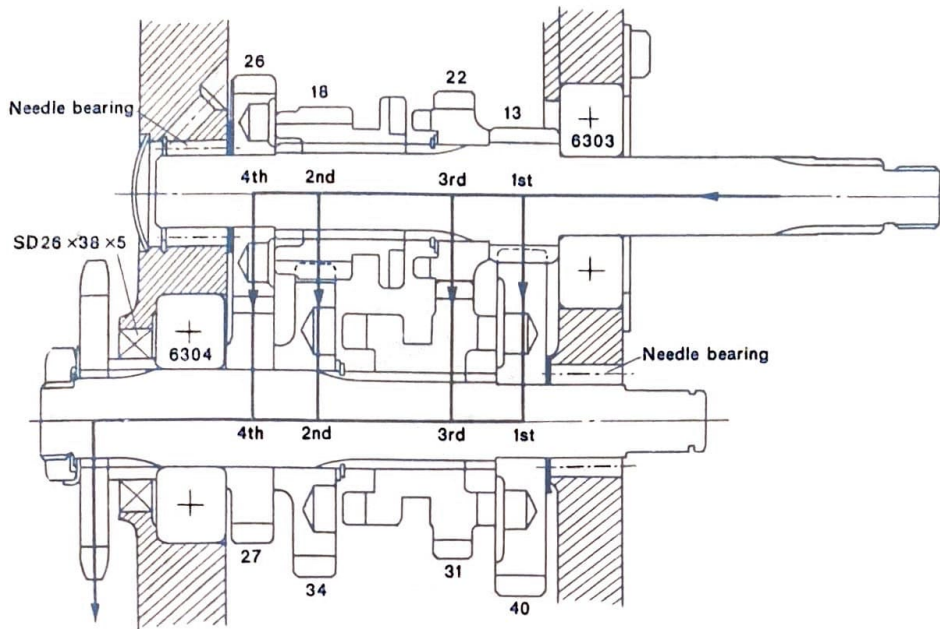
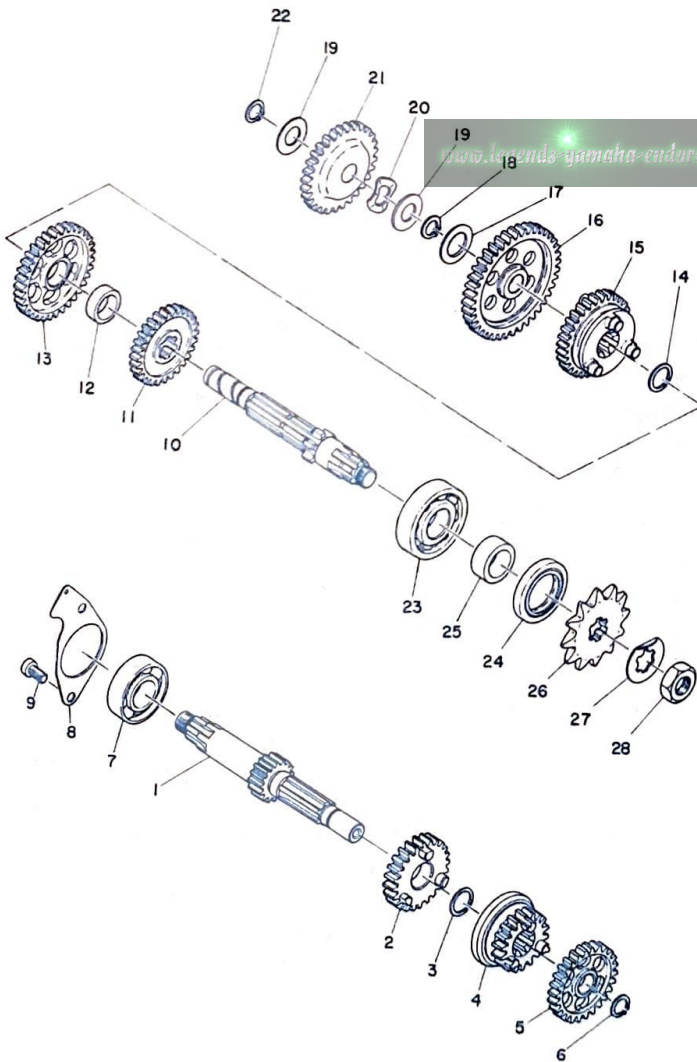

Fig 3-16-1



1. Main axle
2. 3rd pinion gear
3. Circlip
4. 2nd pinion gear
5. 1st pinion gear
6. Circlip
7. Bearing
8. Bearing cover plate
9. Bolt
10. Drive axle
11. 4th wheel gear
12. Distace collar
13. 2nd wheel gear
14. Circlip
15. 3rd wheel gear
16. 1st wheel gear
17. SHIM
18. Circlip
19. Thrust washer
20. Wave washer
21. Kick idle gear
22. Circlip
23. Bearing
24. Oil seal
25. Distance collar
26. Drive sprocket
27. Lock washer
28. Nut

Fig. 3-16-2

A. Removal

- 1) Pull out the two shift fork guide bars.

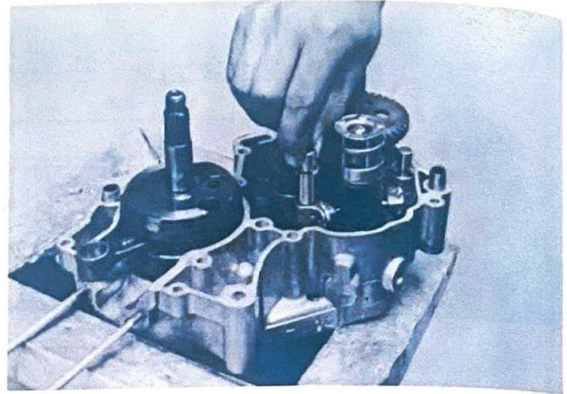
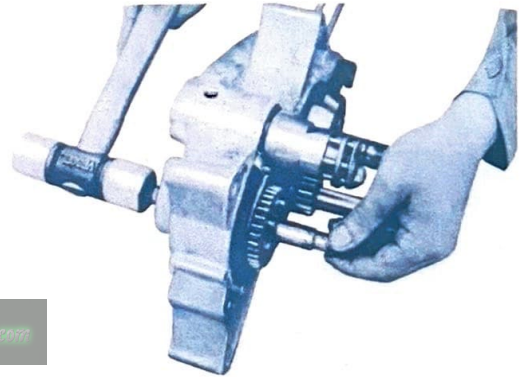

Fig. 3-16-3

- 2) Remove both the transmission assembly and the shift assembly from the crankcase, while tapping the drive shaft end with a soft-faced-hammer.



www.legends-yamaha-enduros.com

Fig. 3-16-4

B. Reinstallation

Reinstall the transmission and shifter as a unit in the left crankcase half after they are sub-assembled. They cannot be installed separately. The transmission unit must be in neutral during installation.

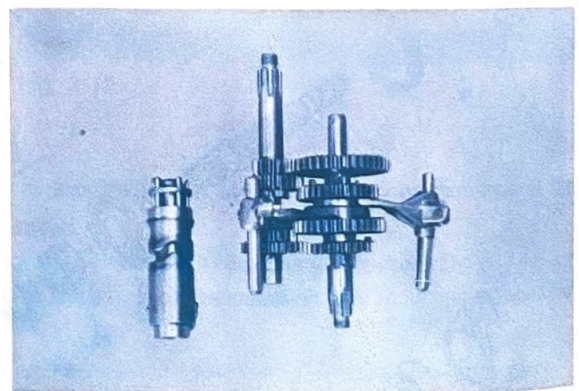
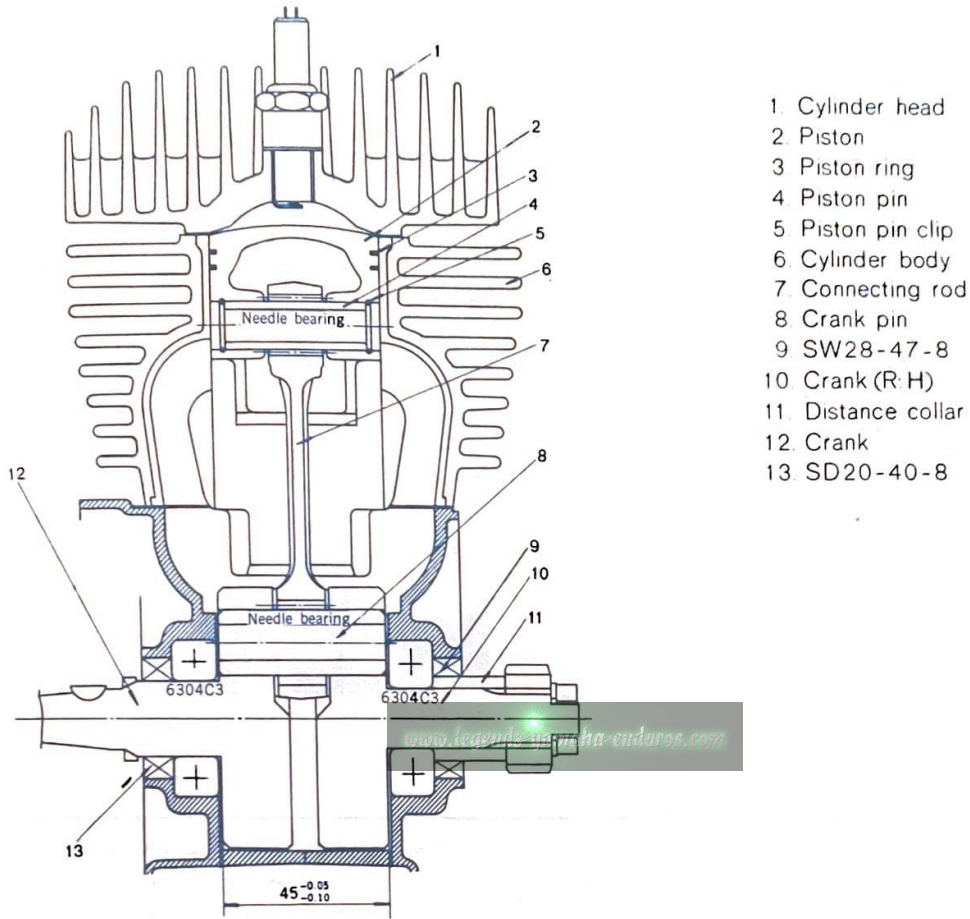

Fig. 3-16-5

3.17 Crankshaft

The crankshaft is a precision piece of work and is subjected to extreme stresses. It should be handled and inspected with special care



1. Cylinder head
2. Piston
3. Piston ring
4. Piston pin
5. Piston pin clip
6. Cylinder body
7. Connecting rod
8. Crank pin
9. SW28-47-8
10. Crank (R: H)
11. Distance collar
12. Crank
13. SD20-40-8

Fig. 3-17-1

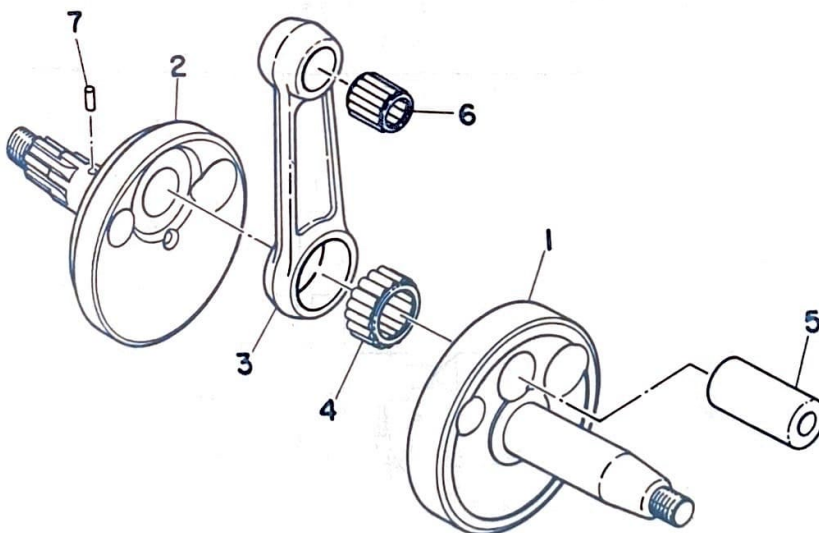

1. Crank left
2. Crank right
3. Rod connecting
4. Bearing con-rod big end
5. Pin crank
6. Bearing con-rad small end
7. Pin dowel

Fig. 3-17-2 Crankshaft component parts

A. Removing the Crankshaft Assembly

Remove the crankshaft assembly with the crankcase separating tool

Note: Fully tighten the bolts of the crankcase dividing tool, and keep the tool parallel with the crankcase surface.

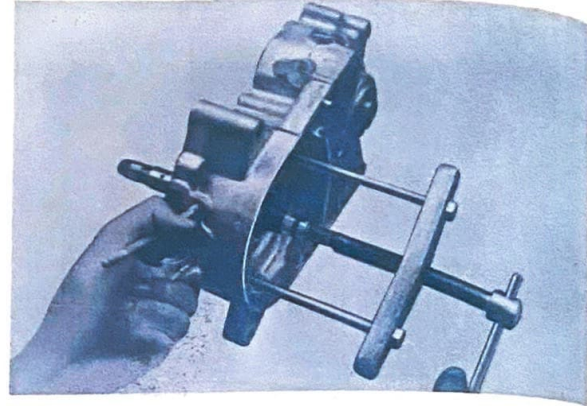
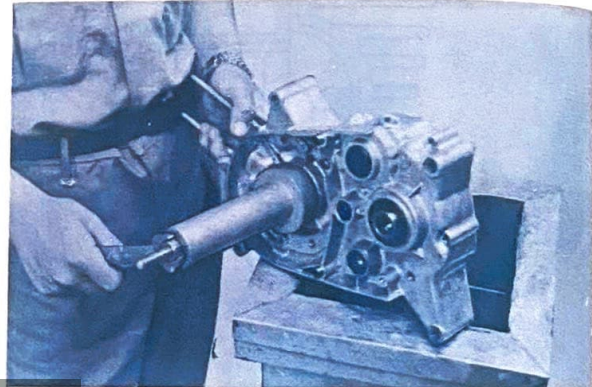

Fig. 3-17-3

B. Installing the Crankshaft Assembly

Install the crankshaft by using the crankshaft fitting tool. Take care not to allow the connecting rod to contact the crank case. For this, hold the piston at top-dead-center and turn the handle then tighten the bolt of the special tool



C. Inspection and Servicing

1) Checking the crankshaft components

www.legends-yamaha-endur.com Fig. 3-17-4

<p>Check connecting rod axial play at the small end (to determine the amount of wear of crank pin and bearing at large end) (Fig 3-17-5)</p>	<p>Small end play should not exceed 2 mm. (0.078 in.)</p>	<p>If small end play exceeds 2 mm, disassemble the crank shaft, check connecting rod crank pin and large end bearing. Replace defective parts. Small end play after reassembly should be within 0.8~1.0 mm. (0.031~0.04 in.)</p>
<p>Check accuracy of the crankshaft ass'y runout. (Misalignment of parts of the crankshaft)(Fig 3-17-6)</p>	<p>Dial gauge readings should be within 0.03 mm. (0.0012 in.)</p>	<p>Correct any misalignment by tapping the flywheel with a brass hammer and by using a wedge.</p>

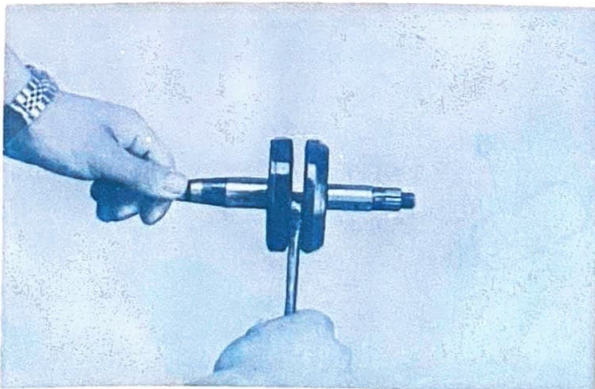

Fig. 3-17-5

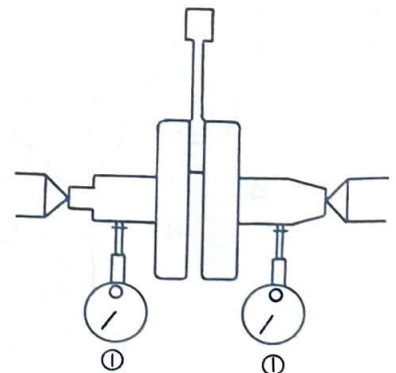

Fig 3-17-6

3-18 Bearings and Oil Seals

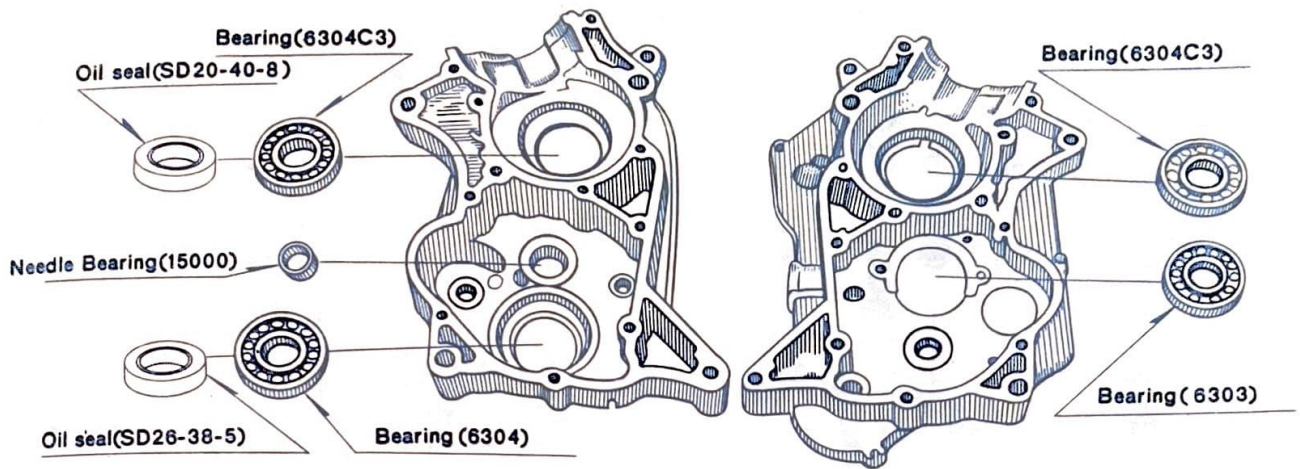

Fig 3-18-1

1. Removal and Installation

1) Removal

- a. Pry the oil seals out of place with a slot head screwdriver. Always replace the oil seals when overhauling the engine

(⊖ Screw driver)

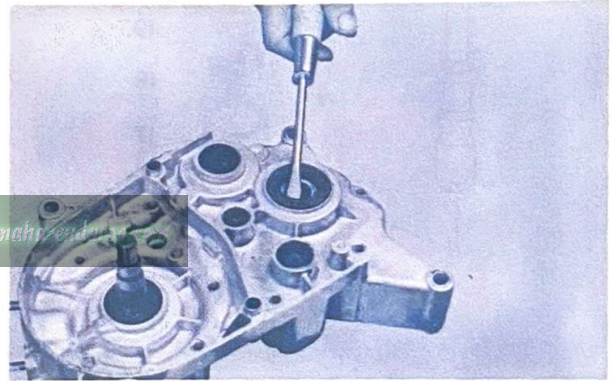

Fig 3-18-2

- b. Drive out the bearing with a bearing tool.

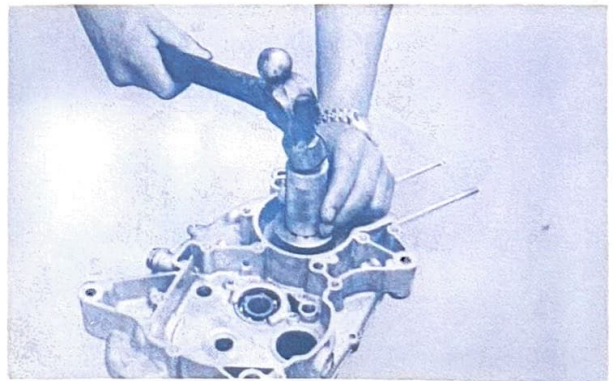

Fig 3-18-3

2) Installation

Install bearings and oil seals with their stamped manufacturer's marks or numerals facing outward. (In other words, the stamped letters must be on the exposed view side.)

When installing bearings, pack them with grease.

3-19 Carburetor

The JT1 is equipped with a Y16P 16 mm Venturi carburetor that is equip-with a built-in starter jet

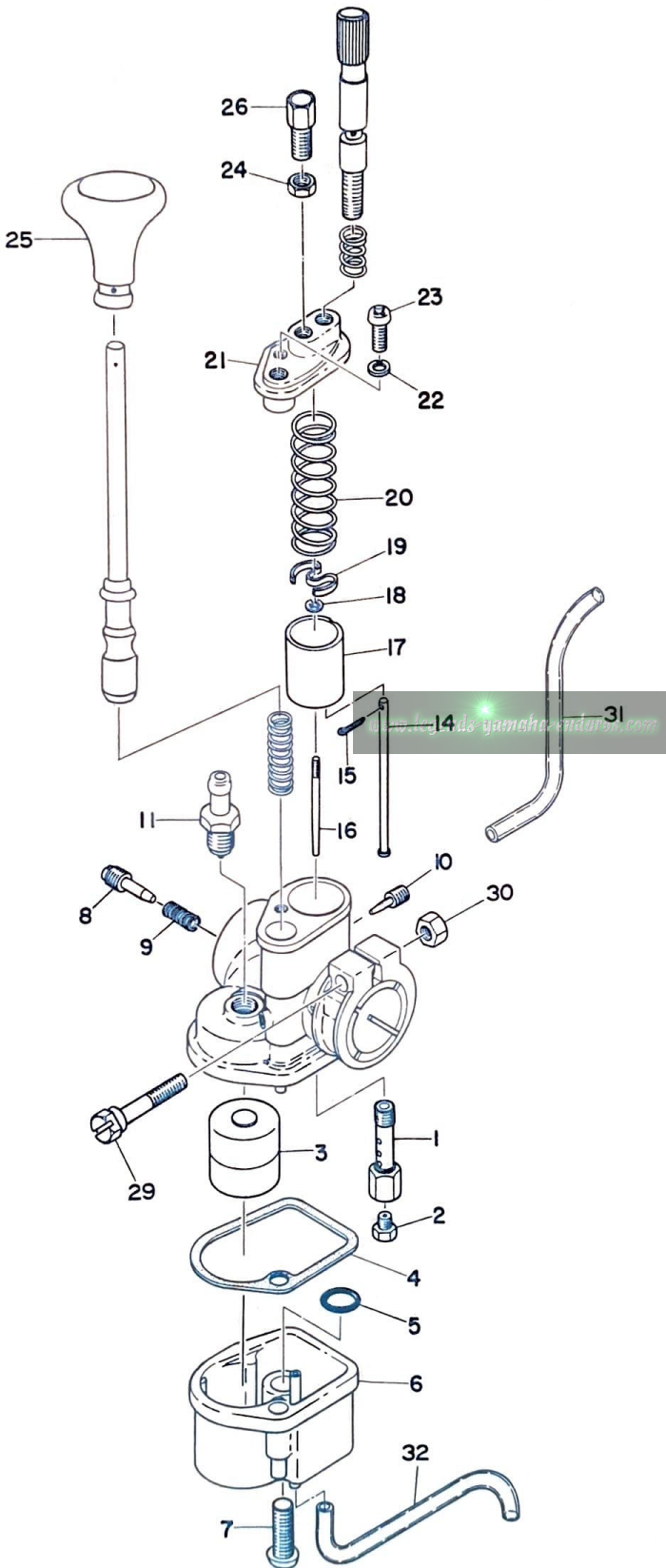

1. Main nozzle
2. Main jet
3. Float
4. Float chamber gasket
5. O ring
6. Float chamber body
7. Pan head screw
8. Air adjusting screw
9. Air adjusting spring
10. Pilot jet
11. Valve seat ass'y
12. Starter plunger ass'y
13. Plunger spring
14. Throttle bar
15. Cotter pin
16. Needle
17. Throttle valve
18. Clip
19. Spring seat
20. Throttle valve spring
21. Mixing chamber top
22. Spring washer
23. Pan head screw
24. Wire adjusting nut
25. Starter knob
26. Wire adjusting screw
27. Throttle stop spring
28. Throttle screw
29. Body fitting screw
30. Nut
31. Air bend pipe
32. Over flow pipe

Fig. 3-19-1 Explasion diagram of carkuretor

A. Checking the Carburetor

1) Float

Remove the float and shake it to check if gasoline is inside. If fuel leaks into the float while the engine is running, the float chamber fuel level will rise and make the fuel mixture too rich. Replace the float if it is deformed or leaking.

2) Float valve

Replace the float valve if its seating end is worn with a stop or if it is scratched. Check the float valve spring for fatigue. Depress the float valve with your finger, and make sure that it properly seats against the valve seat. If the float valve spring is weakened, fuel will overflow, flooding the float chamber while the gas is on.

3) Overflowing

If fuel overflows, check the carburetor as described in 1) and 2) above. If neither 1) nor 2) cures the overflowing, it may be caused by dirt or dust in the fuel preventing the float valve from seating properly. If any dirt or dust is found, clean the carburetor, petcock and gas tank.

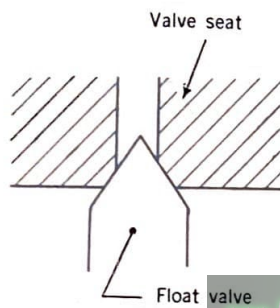

Fig. 3-19-2

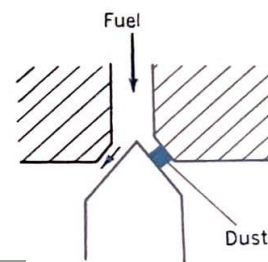

Fig. 3-19-3

4) Cleaning the carburetor

Disassemble the carburetor, and wash all its parts in a suitable solvent

Then blow all the parts off with compressed air. All jets and other delicate parts should be cleaned by blowing compressed air through them after the float bowl has been removed.



Fig. 3-19-4

B. Idle Mixture-Idle Speed Adjustments

The idle Mixture adjustment should be set exactly to factory specifications. First, turn the air screw in until it lightly seats then back it out $1\frac{1}{2}$ turns. Next, adjust the throttle stop so that the engine idles at 1250 ~ 1350 rpm.

C. Carburetor Setting Table

Name of Parts	Abbreviation	Specifications
		JT1
Main jet	M. J	#86
Needle jet	N. J	2.085
Jet needle	J. N	32-2
Pilot jet	P. J	#38
Starter jet	G. S	#50
Throttle valve cut away	C. A	1.5
Air screw setting	A. S	1 ½
Idling speed	—	1300 ±50 rpm
I dent. Mark	—	288 EI

Float Level

With the float bowl removed, note the location and condition of the inlet needle seat on the top of the float. If it is in good condition, float level will be correct. This is due to the fact that as fuel level increases the float is raised until it touches and then shuts off the inlet needle. There is no float arm and shut-off tang as found on other Yamaha models.

3-20 Air Cleaner

A. Removal

- 1) Remove the four bolts mounting the air cleaner case
(⊕ Screw driver)

www.legends-yamaha-enduros.com

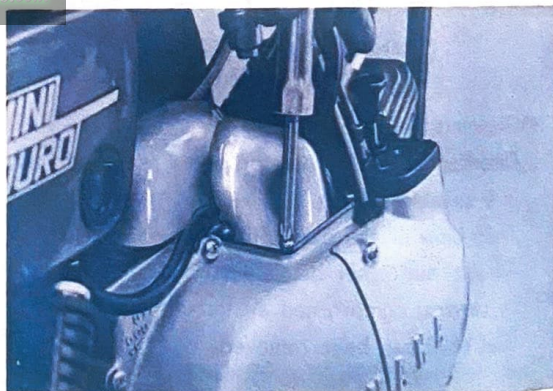

Fig. 3-20-1

- 2) Remove the two bolts mounting the felt retainer.
(⊕ Screw driver)

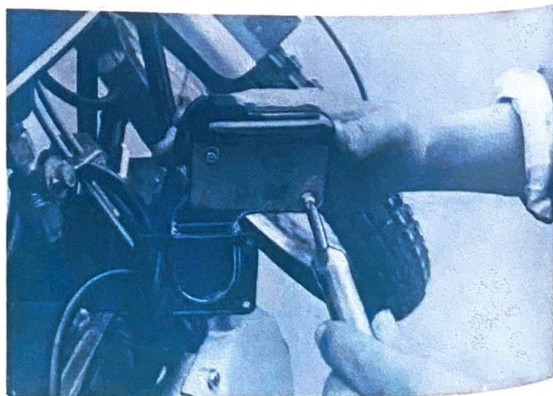

Fig. 3-20-2

3) Remove the felt retainer and take out the element.

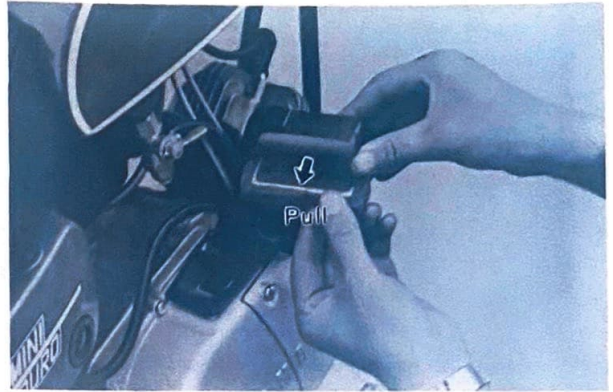

Fig. 3-20-3

B. Cleaning

The element is of the wet type made of foam rubber, and its inner surface is oiled so that its dust removal efficiency and service life have greatly improved as compared with a conventional paper element. Accordingly, it is advisable that the element be washed in solvent mixed with oil (10 : 1) it. After washing, shake off the gasoline and install the element in the case. Never allow the element to dry out as its efficiency will be greatly reduced.

Chapter 4 Chassis

The Yamaha JT1 has been designed for versatility and a combination of uses. This machine has been engineered to have a minimum weight factor. Yet with the reduction in weight, rigidity, strength, and safety have been incorporated in the design of the frame to provide an unexcelled machine.

4-1 Front Wheel

The 15" front wheel is equipped standard with a 2.50-15" Trials Universal tire. This tire gives the rider assurance of maximum performance and safety for both road riding and trail riding. The front wheel brake size is 110 mm x 25 mm (4.33 x 0.98 in.) A labyrinth seal is installed between the wheel hub and brake plate to provide a seal against dust and water.

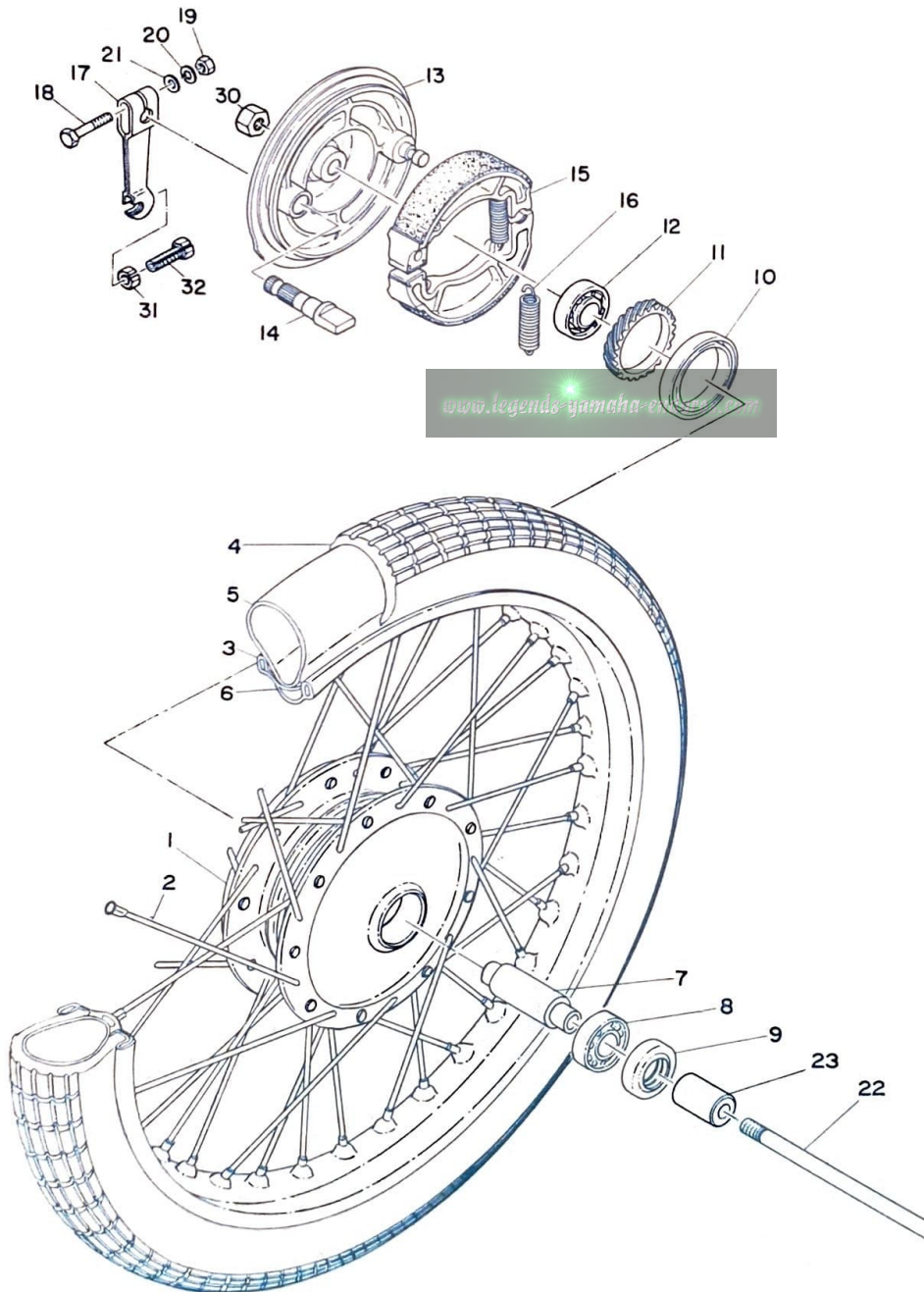

1. Hub
2. Spoke set
3. Rim
4. Front tire
5. Tube
6. Rim band
7. Spacer
8. Bearing
9. Oil seal
10. Oil seal
11. Drive gear
12. Bearing
13. Brake shoe plate
14. Cam shaft
15. Brake shoe comp
16. Return spring
17. Cam shaft lever
18. Bolt
19. Nut
20. Spring washer
21. Plain washer
22. Wheel shaft
23. Wheel shaft collar

Fig 4-1-1

A. Removal

- 1) Disconnect the brake cable from the front wheel hub plate.

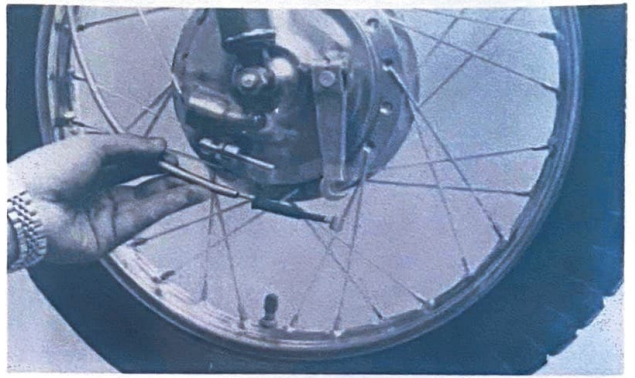

Fig. 4-1-2

- 2) Remove the front wheel nut (17 mm)

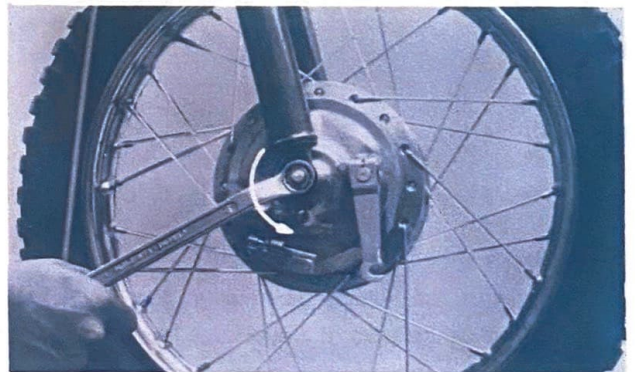

Fig. 4-1-3

- 3) Pull out the front wheel shaft, together with the distance collar, by plier.

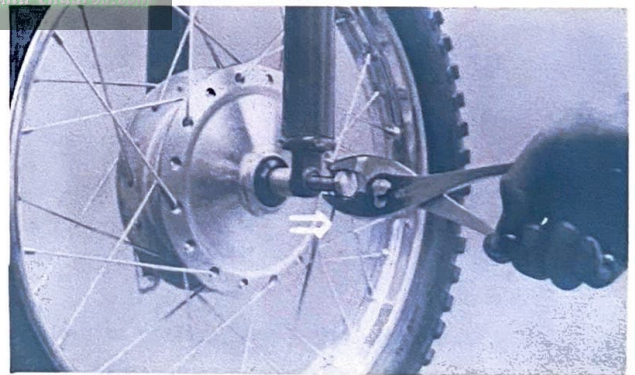

Fig. 4-1-4

- 4) Raise the front of the machine and set it on a box. Then remove the wheel assembly.



Fig. 4-1-5

B. Checking

1) Run out of the rim

As shown in Fig 4-1-6, measure the runout of the rim with a dial gauge. Run out limits: 2 mm (0.07 in.) or less.

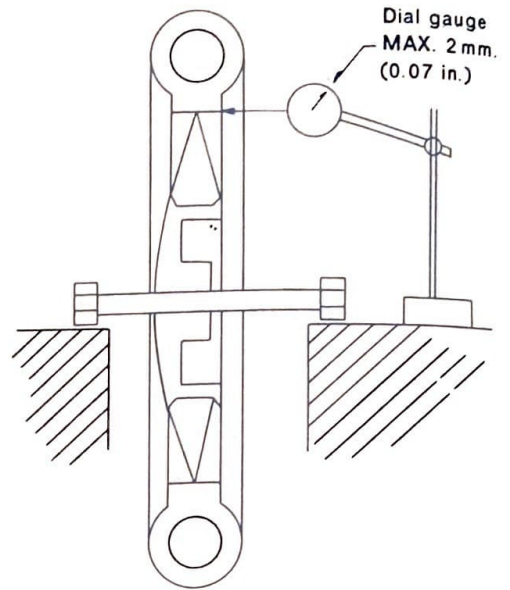

Fig 4-1-6

2) Brake shoe

Measure the outside diameter at the brake shoe with slide calipers. If it measures less than 104 mm (4.09 in.), replace it. Smooth out a rough shoe surface with sand-paper or with a file.

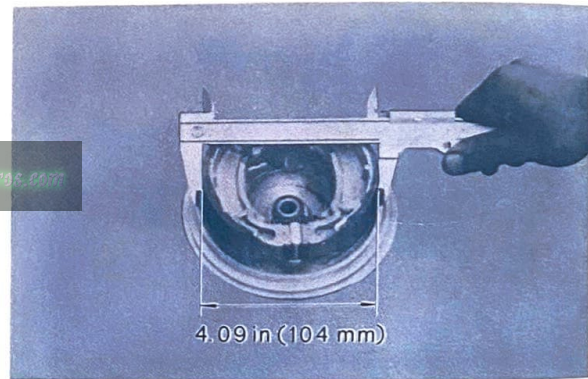

Fig 4-1-7

3) Brake drum

Oil or scratches on the inner surface of the brake drum will impair braking performance or result in abnormal noises. Clean or smooth out the surface with a rag soaked in lacquer thinner or with sand-paper.

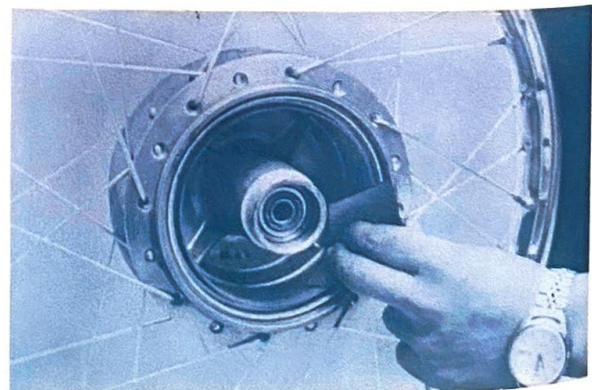

Fig 4-1-8

4) Check the spokes. If they are loose or bent, replace or tighten them. If the machine is ridden in rough country often or raced, the spokes should be checked regularly.

5) Repairing the brake shoe

If the brake shoe has uneven contact with the brake drum or scratches, smooth out the surface with sandpaper or hand file

6) If the tire is excessively worn, replace it.

7) Regularly check the tires for damage.

8) If the bearings allow excessive play in the wheel or if it does not turn smoothly, replace the bearing

9) Replace a bent or damaged front wheel axle.

10) Check the lips of the seals for damage or warpage. Replace if necessary.



Fig. 4-1-9

Replacing the Wheel Bearing

a. First clean the outside of the wheel hub.

b. Insert the bent end of the special tool (as shown in Fig 4-1-11) into the hole located in the center of the bearing spacer. and drive the spacer out from the hub by tapping the other end of the special tool with a hammer. (Both bearing spacer and spacer flange can easily be removed.)

c. Then pushes out the bearing on the other side.

d. To install the wheel bearing, reverse the above sequence. Be sure to grease the bearing before installation and use the bearing fitting tool (furnished by Yamaha)

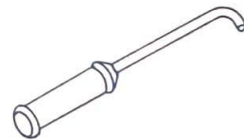
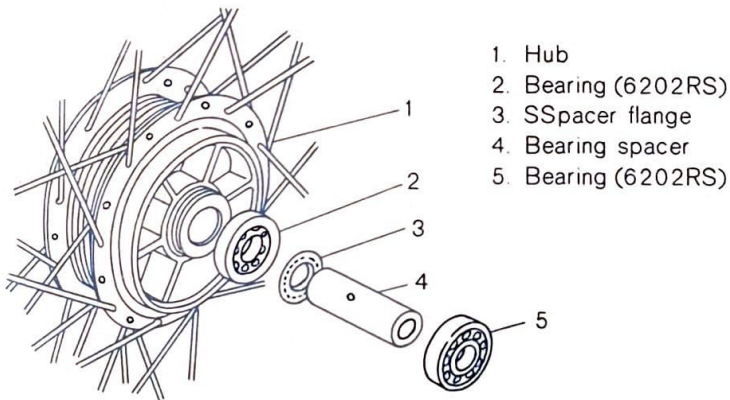

Insert the bent end of the special tool into the hole located in the center of the bearing spacer.

Fig. 4-1-10

Fig. 4-1-11

4-2 Rear Wheel

The rear wheel is 15-in. size, and the rear tire is the 2.50-15 Trials Universal. The single leading shoe type brake is 130 mm. x 28 mm. (5.12 x 1.10 in.) in size. A labyrinth seal between the wheel hub and the brake plate is provided to prevent water and dust leakage. The brake tension bar is of link design to minimize the shifting of the brake cam lever position when the rear swing arm is moving up and down.

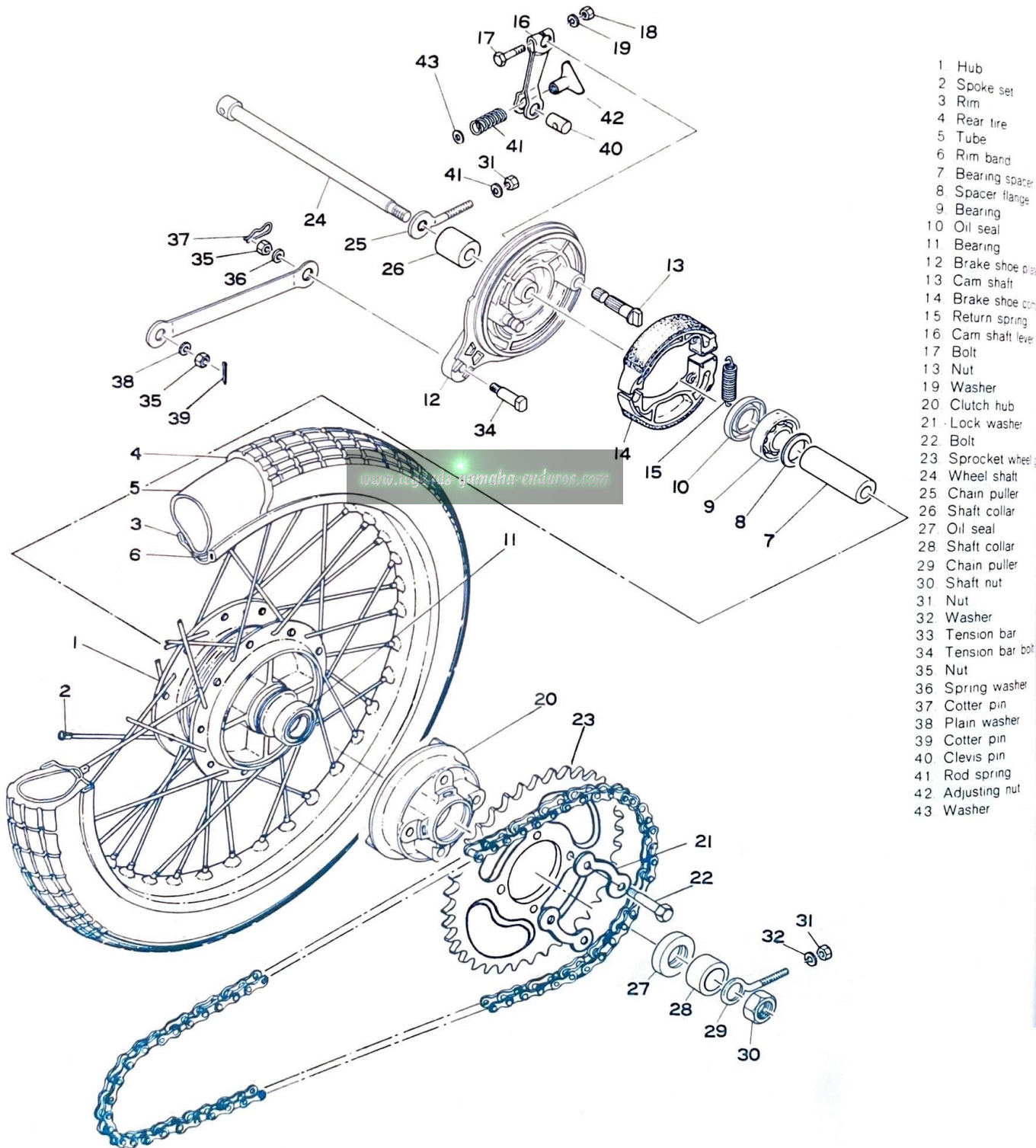

Fig. 4-2-1 Rear Wheel Construction

A. Removal

- 1) Remove the tension bar and brake rod from the rear shoe plate.
(10 mm, nose plier)

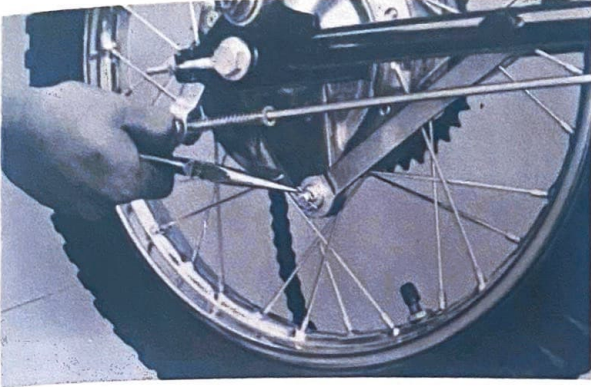

Fig 4-2-2

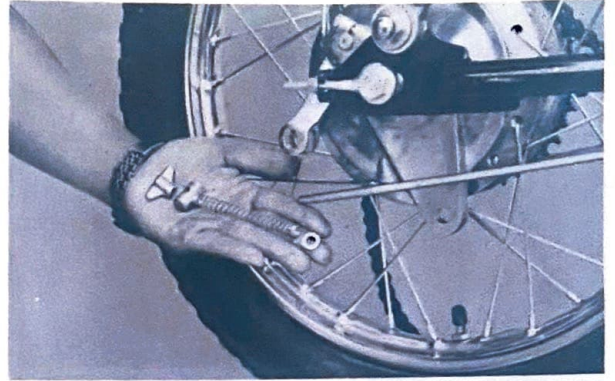
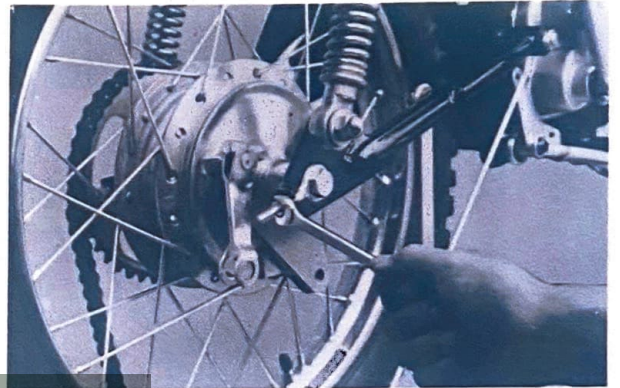

Fig 4-2-3

- 2) Loosen the chain tension adjusting nut and bolt on both right and left sides.
(10 mm)



www.legends-yamaha.com Fig 4-2-4

- 3) Remove the rear wheel shaft nut
(19 mm)

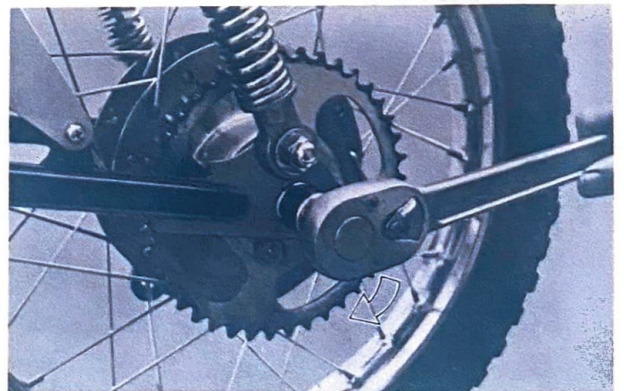

Fig 4-2-5

- 4) Pull out the rear wheel shaft by striking it with a soft-faced-hammer

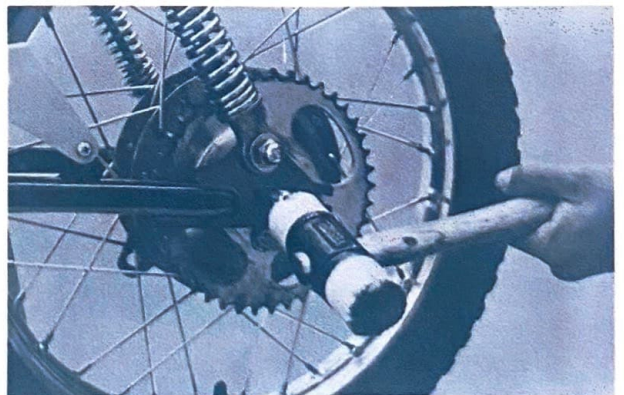

Fig 4-2-6

5) Remove the right-hand chain adjuster and distance collar

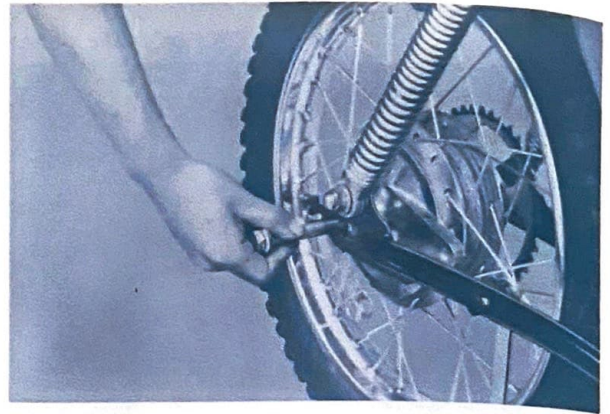

Fig 4-2-7

6) Remove the rear brake plate.

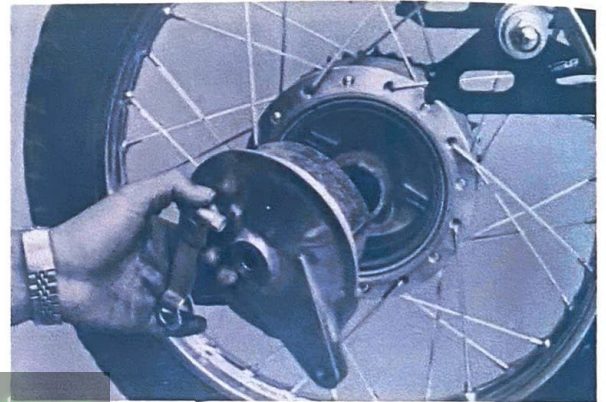

Fig. 4-2-8

7) Lean the machine to the left and remove the rear wheel assembly

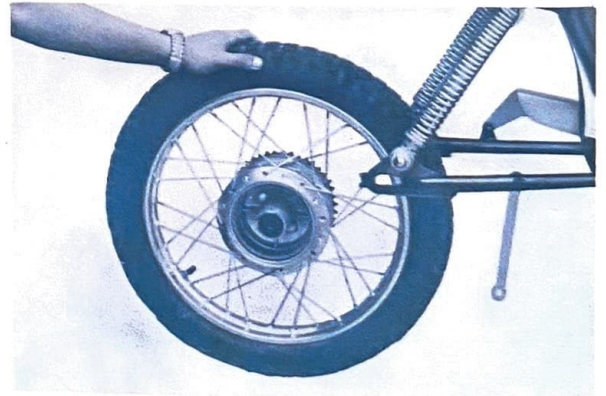

Fig 4-2-9

Replacing the Wheel Bearing

Replace the rear wheel bearing in the same way as the front wheel bearing

Replacing Tires

1) Removal

- a. Remove the valve cap and lock nut (12 mm.) from the tire valve, and deflate the tire.
- b. Remove the tire from the wheel rim by the use of two tire levers. (Exercise care to avoid damaging the inner tube with the levers.)

It is noted that to remove the inner tube, one side of the tire should be pried out of the wheel rim.

2) Installation

- a) Insert the tube between the tire and the wheel rim, and partially inflate the tube. Be sure that the valve stem is directed toward the wheel shaft. At this time the tire is still halfway off the rim.
- b) Force the tire completely back on the wheel rim by the use of tire levers. For this operation, it is advisable that the bead on the opposite side of the rim be pushed in toward the rim flange.
- c) To avoid pinching the tube between the tire and the rim, drive the tire on with a soft-faced hammer after the tire is partially installed.
- d) Tighten the tire valve lock nut and inflate the tire to the recommended pressure, then install the valve cap.

B. Inspection

- 1) Run out of the rim
Check the rim for run out in the same way as the front wheel. Maximum limit of runout.....2 mm.(0.07 in) or less
- 2) Brake shoe
Check the brake shoe in the same way as the front wheel. Minimum limit124 mm (4.9 in)
- 3) Brake drum
Check the brake drum in the same way as the front wheel.
- 4) The spokes are measured in the same way as the front wheel. A loose spoke should be tightened.
- 5) If the bearing has excessive play or it does not turn smoothly, replace it.
- 6) If the tire or the pattern is worn out, replace the tire.
- 7) If the lip of the oil seal is damaged or warped, replace it.

4-3 Rear Wheel Sprocket

A. Checking and Adjustment

The rear wheel sprocket is installed on the clutch hub. To replace the sprocket, take the following steps

- 1) Removing the sprocket
 - a. Bend the lock washer ears flat
(flat chisel)

www.legends-yamaha-enduros.com



Fig. 4-3-1

- b Remove the sprocket mounting bolts.
(14 mm)



Fig. 4-3-2

2) Checking

Check the lock washer and hexagonal bolt for breakage and damage. If the lock washer is not bent, over the hexagon bolt head, or is broken, or if the bolt is loose, the sprocket can come loose. Make sure that both lock washers and the mounting bolts are tight.

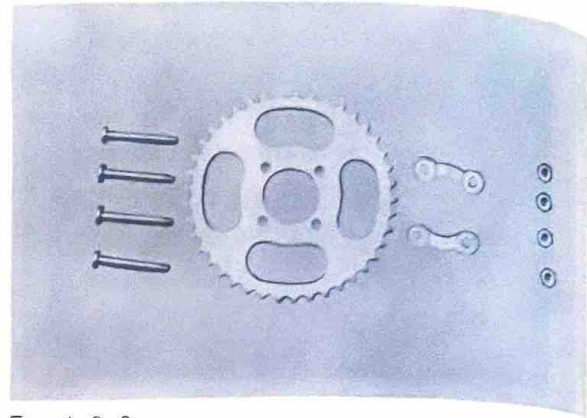

Fig 4-3-3

4-4 Tires and Tubes

1) Normal tire pressure

Though tire pressure is the rider's choice, the standard tire pressure is as follows.

Front.....22.4 lbs./in²(1.6 kg./cm²)

Rear..... 28.0 lbs./in²(2.0 kg./cm²)

When the tire pressure is reduced below the specified value because of some reason, the tire may slip around the rim.

4-5 Front Forks



The JT1 is equipped with competition designed telescopic double dampening front forks. These specially designed front forks provide excellent riding comfort along with handling superiority. The maximum stroke travel is almost 3.0 inches (75 mm.)

The combination of fork stability and long stroke travel provides safety and handling ease for the rider over even the roughest terrain. This front forks design also reduces weight, eases maintenance, and gives the machine an attractive appearance. The simplicity and dependability of the front forks is aided the installation of the fork spring inside of the fork tube.

- 1) Remove the inner tube cap bolt
 You must loosen the arrow marked pinch bolt before
 the cap bolt is loosened.
 (17 mm)

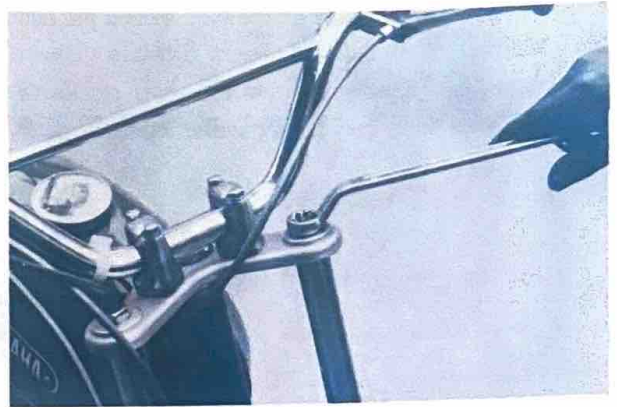
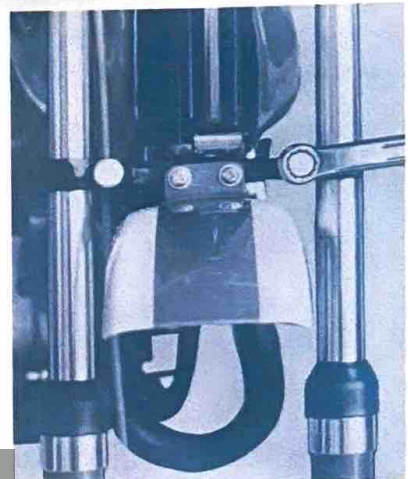

Fig. 4-5-2

- 3) Loosen the inner tube pinch bolt on the under-
 bracket.
 (14 mm)



www.legends-yamaha.com Fig. 4-5-3

- 4) Pull the outer tube downward.

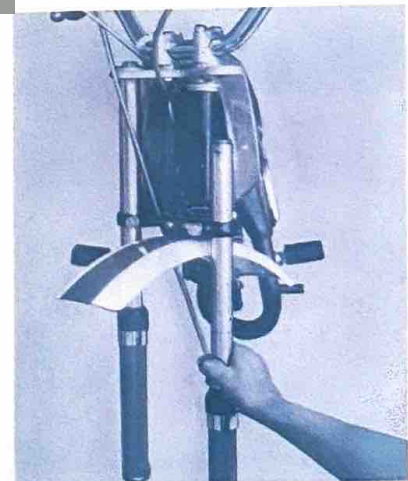

Fig. 4-5-4

B. Disassembling the Inner and Outer Tubes

- 1) Drain the oil from the fork



Fig. 4-5-5

2) Place a rubber sheet or tire tube around the outer tube nut, install a strap wrench, and turn it counter clockwise. handle, and turn it counter clockwise. The inner tube can be separated from the outer.

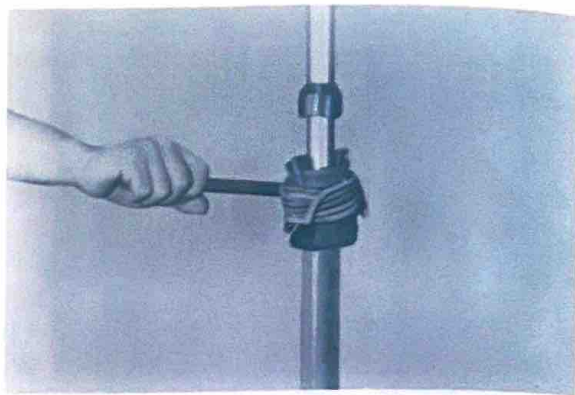

Fig. 4-5-6

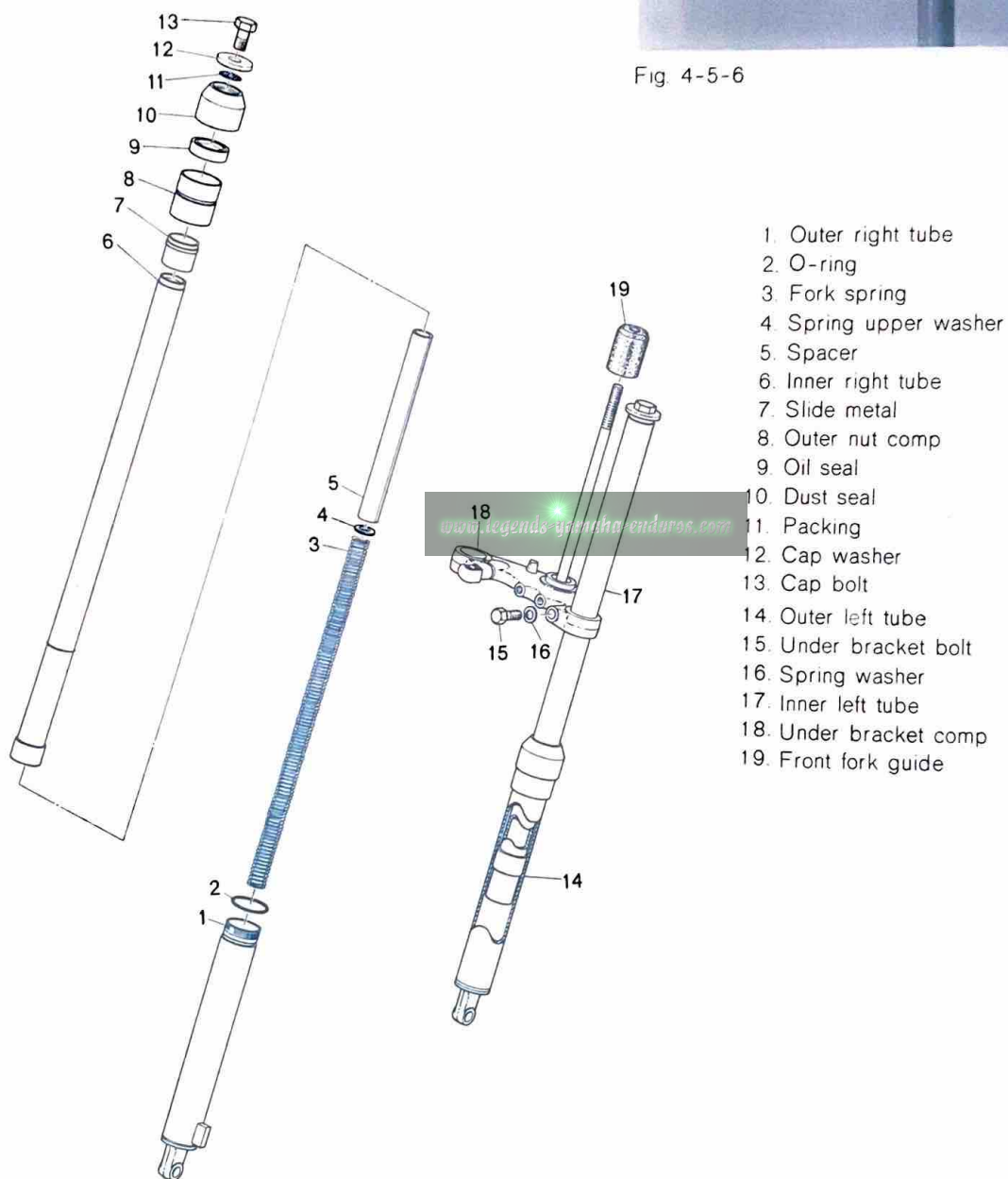

Fig. 4-5-7 Front Fork Exploded View

C. Checking

1) Inner tube

Check the inner tube for bends or scratches. If the bend is slight, it can be corrected with a press. It is recommended, however, to replace the tube if possible.

2) Oil seal

When disassembling the front fork, replace the oil seal in the outer tube nut.

D. Assembling

1) When assembling the front fork, reverse the order of disassembly. Check if the inner tube slides in and out smoothly.

2) Installing the front fork on the frame

a. Bring up the front fork to the correct position and tighten the under bracket mounting bolt.

slightly. Fill the fork tube with oil (see below) and tighten the cap bolt thoroughly. Then tighten the remaining pinch bolts.

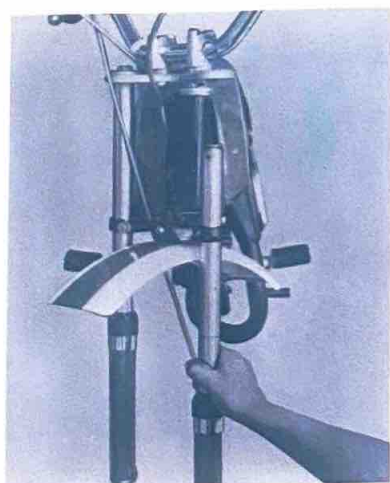

Fig. 4-5-8

b. Pour oil into the inner tube through the upper end opening. Front fork oil:

Motor oil 10 w/30 Right 97 cc (3.3 fl. oz)

Left 120 cc (4.1 fl. oz)

c. Install the cap bolt.

4-6 Rear Shocks

The rear shocks have a maximum stroke of 55 mm (2.16 in.)

A. Checking the Condition of the Damping Units.

1) Remove the rear shock assembly.

(17 mm)

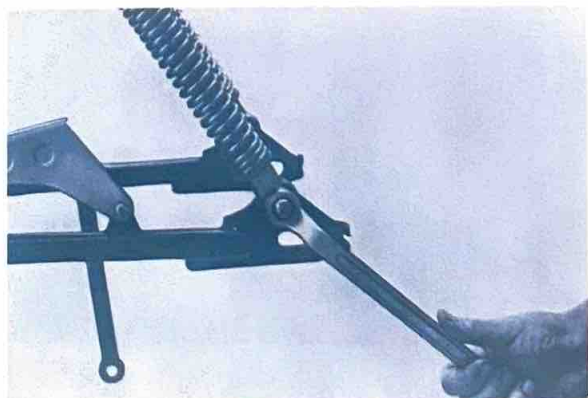

Fig. 4-6-1

- 2) Make sure that the rear cushion moves up and down completely from bottom to top.

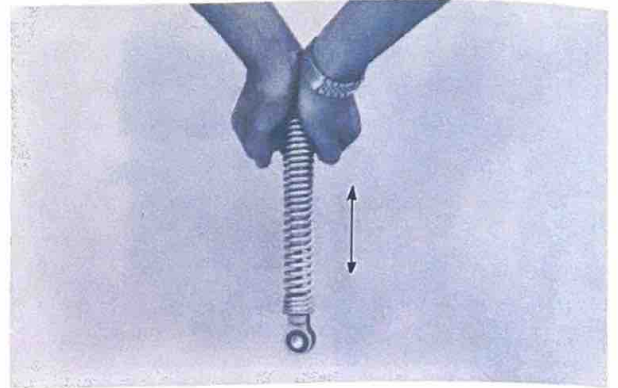

Fig 4-6-2

4-7 Gas Tank

A. Removing

- 1) Pull out the seat fitting pin and remove the seat by pulling it backward.

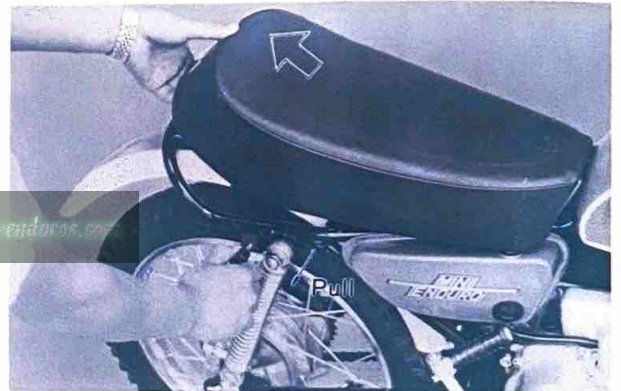

Fig 4-7-1

- 2) Set the petcock lever at the "Stop" position and disconnect the fuel line at the petcock.

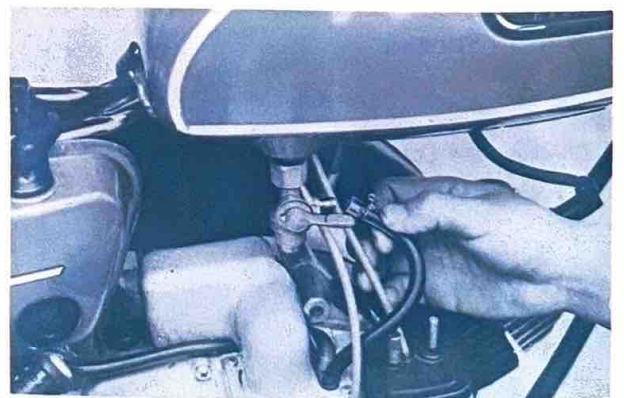

Fig 4-7-2

- 3) Next, remove the tank holding bolt and remove the tank by pulling it backward.
(13 mm)

4-8 Rear Swing Arm

The rear swing arm is made of steel tubing that improves the strength and torsional rigidity. The pivot employs permanently lubricated bearings.

A. Removing

- 1) Remove the two chain case mounting bolts.
(⊕ Screw driver)

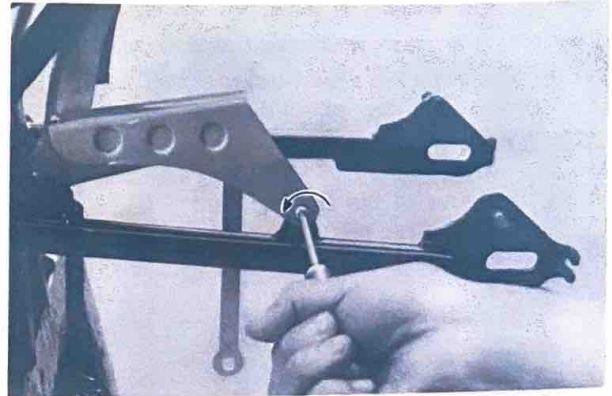

Fig 4-8-1

- 2) Remove the rear swing arm shaft nut, pull out the shaft, and remove the rear swing arm.
(17 mm)

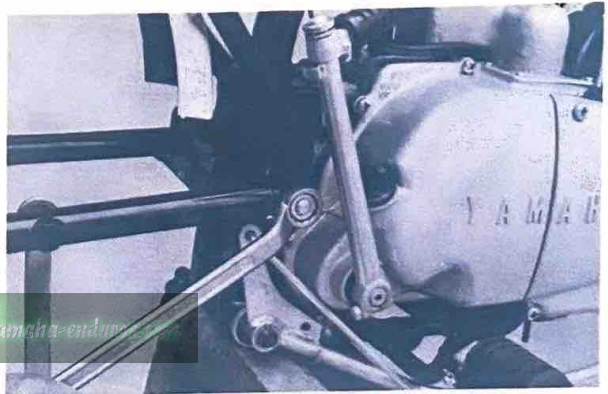

Fig 4-8-2

B. Checking

- 1) Check the play of the rear swing arm by shaking it as show in Fig. 4-8-3, with the rear swing arm installed.
If the play is excessive, replace the rear swing arm bushing or the rear swing arm shaft
- 2) Insert the bushing as indicated in Fig 4-8-4, and check it for play. If the play is excessive, replace the bushing

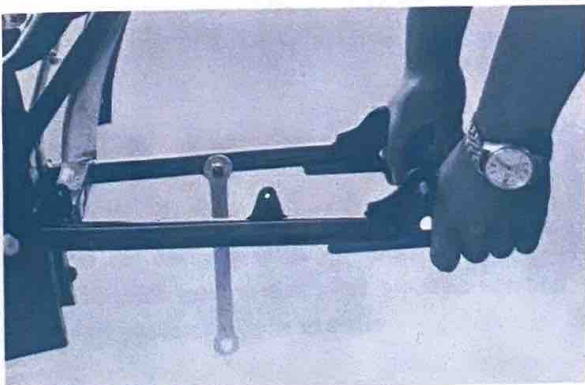

Fig 4-8-3

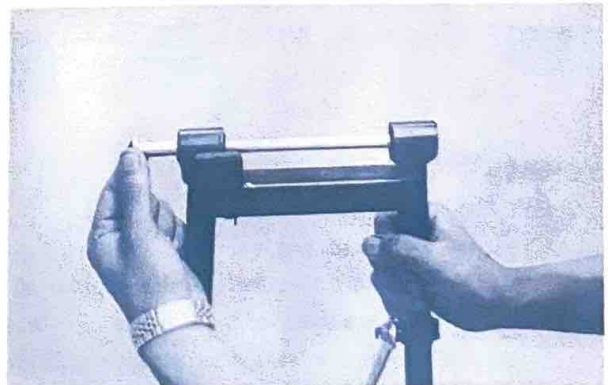

Fig 4-8-4

- 3) Grease the rear arm shaft periodically

Replacing Rear Swing Arm Bushings

On motorcyclers being used only for-the-street riding, rear swing arm bushings should be replaced every 10,000 km. (6,000 miles) The same may not apply to those used for racing or rough riding. Replacement should be made according to machine condition such as excessive play of the rear swing arm, or hard steering (wander, shimmy or rear wheel hop,) or upon request of the customer.

4-9 Steering Head

A. Sectional View of the Steering Head

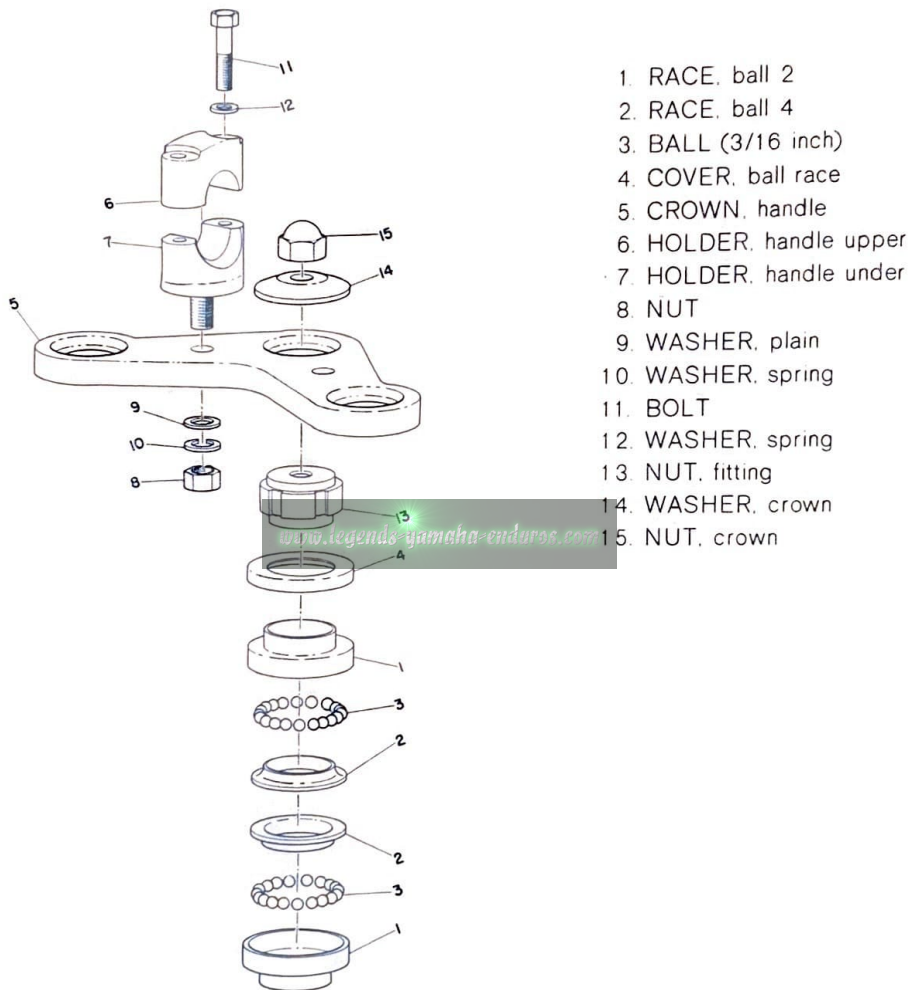

Fig. 4-9-1

B. Checking

1) Ball Races and Steel Balls

Check the ball races and steel balls for pitting or wear. Check them very carefully if the machine has been in long use. If they are worn or cracked, replace all of them, because defective ball races or steel balls adversely affect the maneuverability of the machine. Replace any ball race having scratches or streaks resulting from wear. Clean and grease the balls and races periodically.

Note: Do not use a combination of new balls and used races or vice versa. If races or vice versa. If any of these are found defective, replace the whole ball and race assembly.

4-10 Oil Tank, and Tool Box

The oil tank is located on the right side under the seat. It is designed to be as narrow as possible so that it will not contact the rider's lower limbs when he stands upright on the footrests. To fill the autolube oil tank, lift the seat and the tank cap will be exposed. Oil tank capacity.....1.0 litres (1.1 u. s qts)

4-11 Frame

The double cradle-type frame is made of high tension steel tubes that provide strength, rigidity and light weight. Other dimensional features include high ground clearance, narrow width, and long wheelbase. The engine is bolted to the frame at three positions. The caster is measured at 63 50°

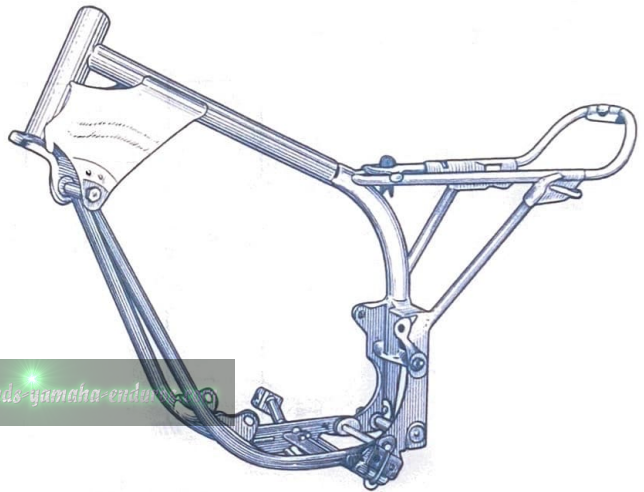

Fig 4-11-1

4-12 Handlebars

The upswept type longer handlebars are ideal supeeion leverage on rough terrain and provided with deep-cut pattern grips to prevent hand slippage.

4-13 Miscellaneous

The footrest is made of a single steel tube extending under the lower part of the frame, and bolted to the frame. The engine guard is bolted to the frame to protect the entire crankcase.....covering from the exhaust system to the drain plug

CHAPTER 5 ELECTRICAL SYSTEM

5-1 Description

The JT1 employs a flywheel magneto for its ignition system.

5-2 Table of Component Parts

Parts	Manufacturer	Model & Type
Flywheel magneto	Hitachi Ltd.	F11-L42
Spark plug	NGK	B-7HS

5-3 Connection Diagram

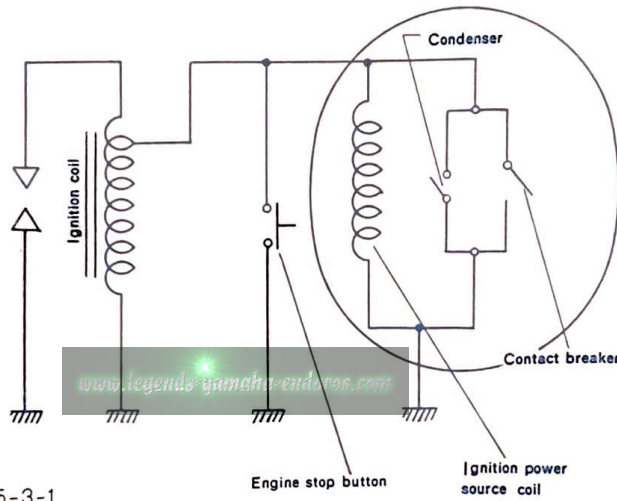

Fig 5-3-1

5-4 Ignition System—Function and Service

1. Function

The ignition system consists of the components as shown in Fig 5-4-1. As the flywheel rotates, the contact breaker points begin to open and close alternately. This make-and-break operation develops an electromotive force in the ignition power source coil, and produces a voltage in the ignition coil primary windings.

The ignition coil is a kind of transformer with a 1 : 50 turn ratio of the primary to the secondary windings. The voltage (150–300 V) which is produced in the primary coil, is stepped up to 12,000 - 14,000 V by mutual-induction and the electric spark jumps across the spark plug electrodes.

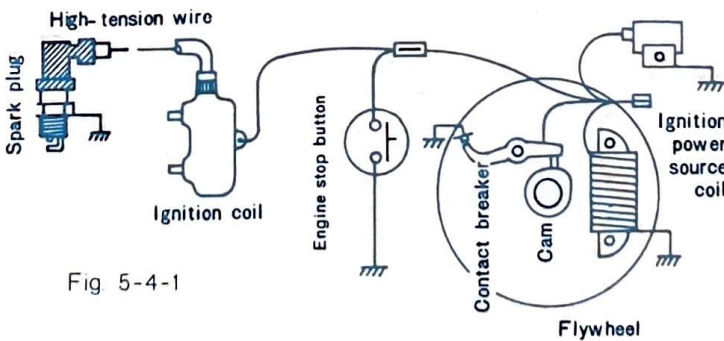

Fig 5-4-1

5-5 Ignition Timing

Remove the spark plug and screw the dial indicator holder into the plug hole. Next, insert the dial indicator into the holder. Bring the piston up to T.D.C. and set the zero on the dial face to line up exactly with the dial indicator needle. The crankshaft should then be turned backwards, so that the piston travels down past 1.8 mm B.T.D.C. and slowly brought back up to precisely 1.8 mm B.T.D.C. (This removes any slack in the gears.) Adjust the points so that they are just beginning to open with the piston in this position. A low resistance point checker (100 Ohms or less) should be used to determine the opening and closing of the ignition points.

Ignition Timing, 1.8 mm. B. T. D. C.

Maximum ignition point gap 0.3 to 0.4 mm. (0.012"—0.015")

5-6 Ignition Coil

Primary coil resistance value..... 4.9 Ω $\pm 10\%$ (20°C or 68 F)

Secondary coil resistance value 11 K Ω $\pm 20\%$ (20°C or 68 F)

(For measuring methods, refer to Fig. 5-6-1)

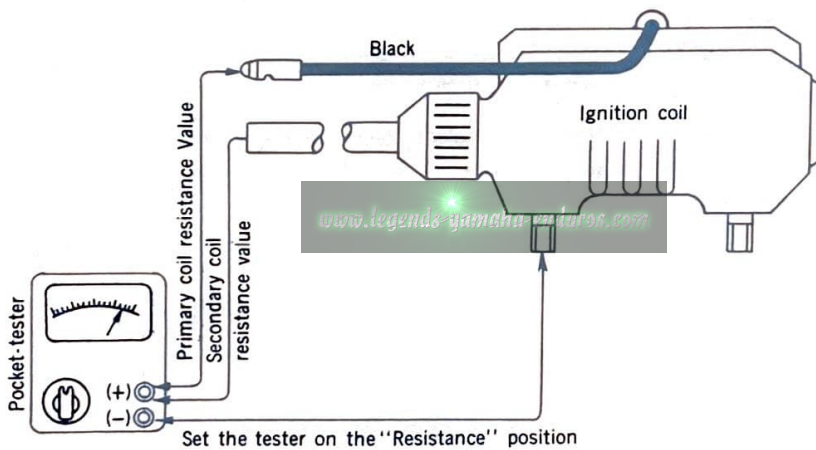

Fig. 5-6-1

Note: When measuring the secondary coil resistance value, disconnect the plug cap. Otherwise, the resistance of the 5K Ω noise suppressor incorporated in the plug will be added to the tester reading.

Spark Test:

Remove the spark plug from the cylinder head and reconnect the high voltage lead. Then hold the spark plug approximately 7 mm away from the head and see if it sparks as you crank the kickstarter.

If it sparks at 7 mm. or so, and has blue white color, the ignition coil should be considered to be in good condition.

5-7 Condenser

The condenser instantly stores a static electric charge as the contact breaker points separate, and the energy stored in the condenser discharges instantly when the points are closed. If it were not for the condenser, an electric arc would jump across the separating contact points, causing them to burn.

Burned contact points greatly affect the flow of current in the primary winding of the ignition coil. If the contact points show excessive wear, or the spark is weak (the ignition coil is in good condition) check the condenser

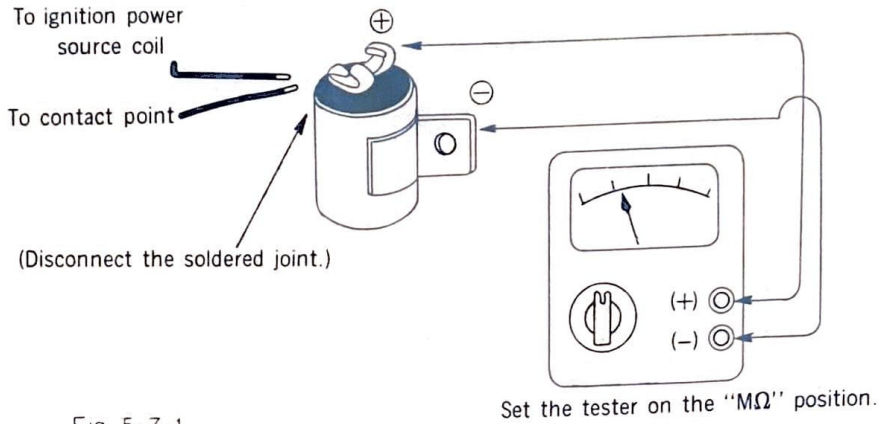

Fig 5-7-1

Insulation resistance tests should be conducted by connecting the tester as shown in Fig 5-7-1. If the pointer swings fully and the reading is more than $3M\Omega$, the insulation is in good condition. If the insulation is faulty, the pointer will stay pointing at the uppermost reading, indicating very little resistance.

Note: After this measurement, the condenser should be discharged by connecting the positive and negative sides with a thick wire.

Capacity tests can be performed by simply setting an electrotester to the condenser capacity. The tester should be connected with the condenser in the same way as in the case of the insulation resistance test. Before this measurement, be sure to set the tester correctly. If the reading is within $0.2\mu F \pm 10\%$, the condenser capacity is correct.

JT1 Wiring Circuit Diagram

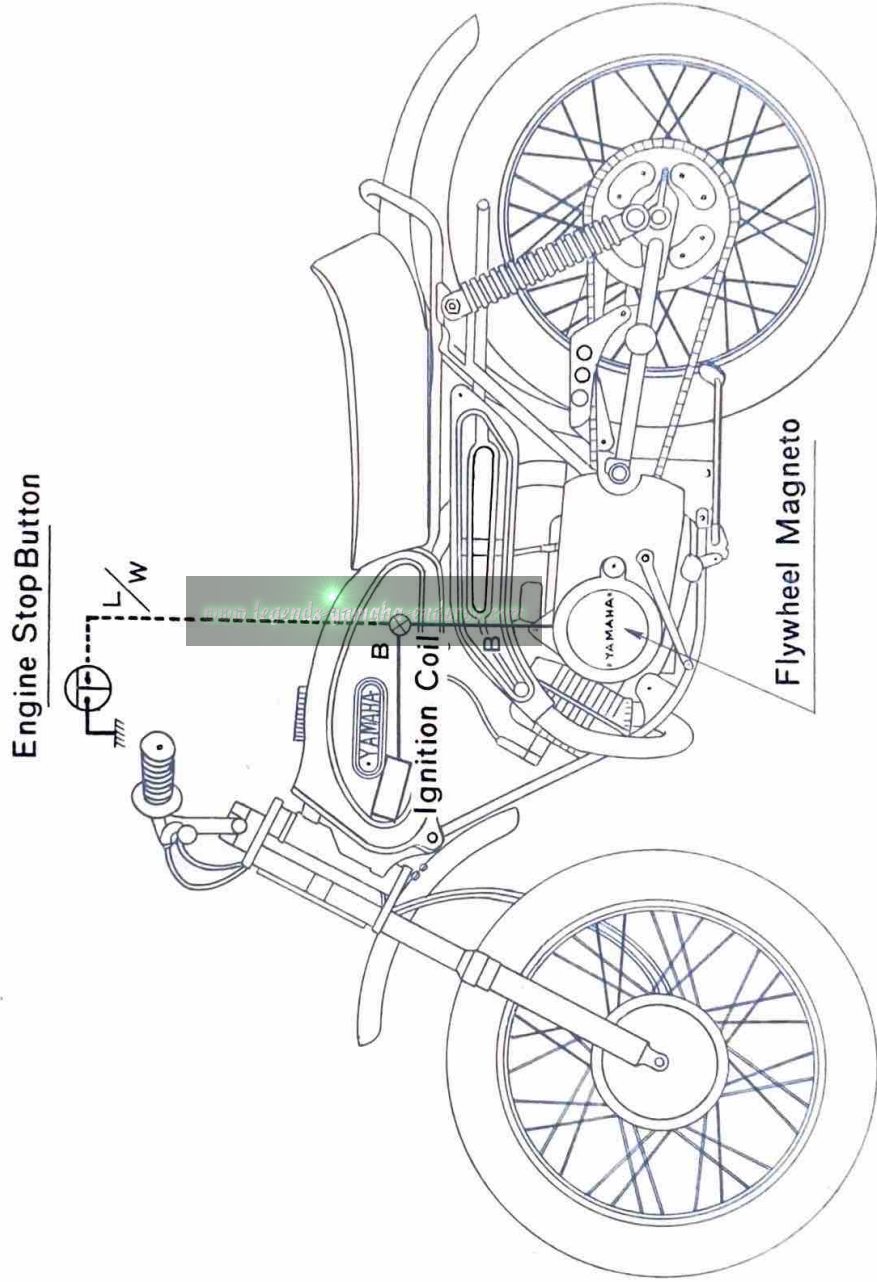

www.legends-yamaha-enduros.com



YAMAHA MOTOR CO., LTD.

45.8X5.500 Printed in Japan