

JT 1 AND 2 ENDURO

Displacement: 58cc
Bore and Stroke: 42 x 42mm
Number of Cylinders: 1
Use: Trail
Cylinder Head Volume: 7.8cc
P/N 259-11111-01-94
Carburetor Size: Y 16 P
P/N 288-14301-00-00
Ignition Timing: 1.8mm BTDC
Spark Plug Heat Range: NGK B 7 HS

Special Parts:

Wide Ratio Transmission

JT 1 AND 2 ENDURO

Port Diagram
Cylinder Part No. 259-11311-00-00
All Dimensions in Millimeters:
Tolerance: $\pm 0.5\text{mm}$

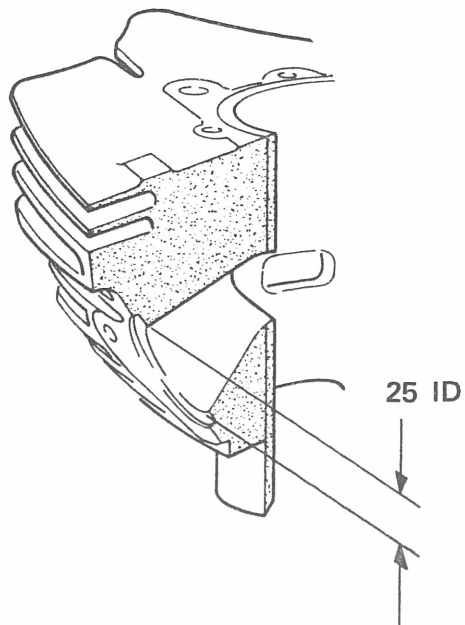
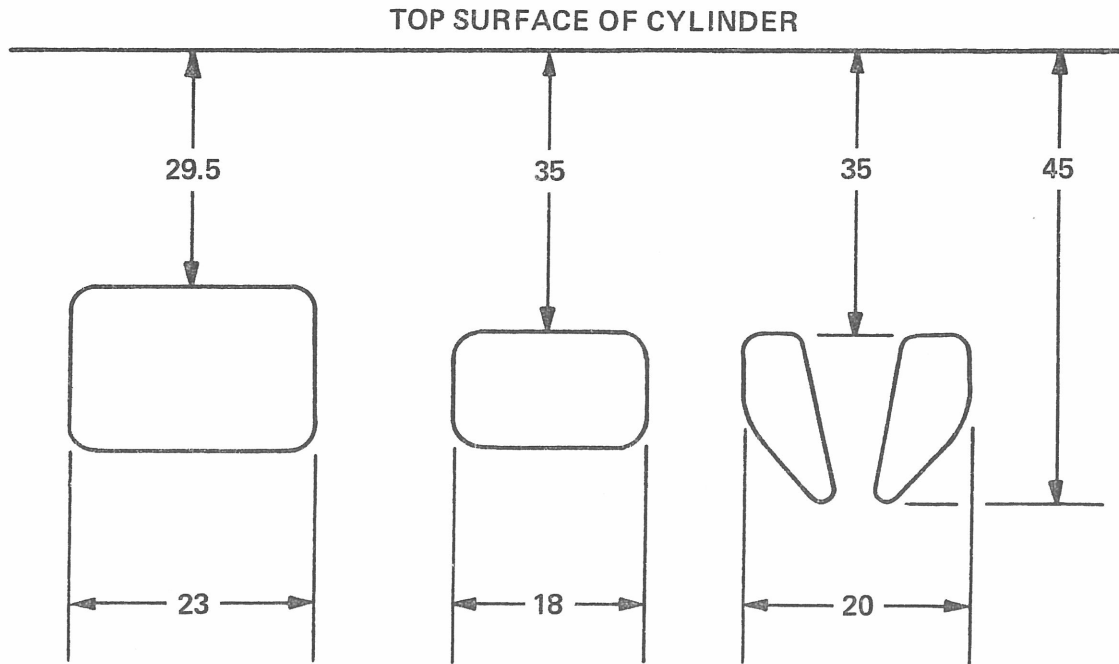

JT 1 AND 2 ENDURO

Piston Diagram
Piston Part No. 289-11631-00-96
All Dimensions in Millimeters:
Tolerance: $\pm 0\text{mm}$

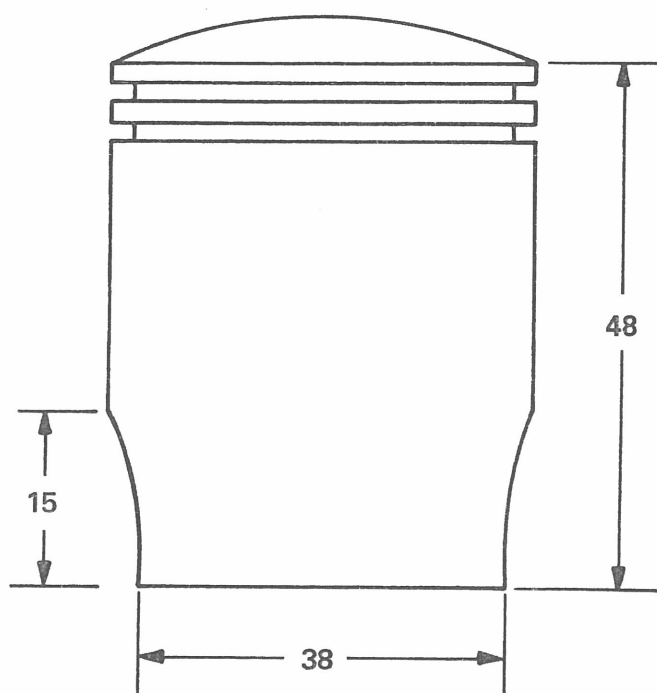

1972

JT 1 AND 2 ENDURO

Rotary Valve Diagram

Rotary Valve Part No. 257-13512-00-00

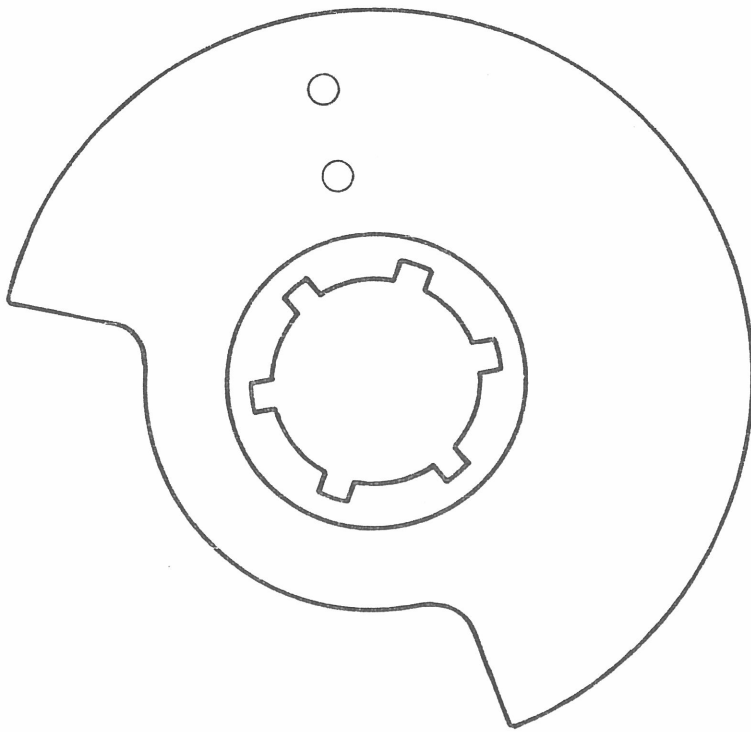

JT 1 AND 2 SPECIAL

Displacement: 58cc
 Bore and Stroke: 42 x 42mm
 Number of Cylinders: 1
 Use: Motocross, Short Track and TT
 Cylinder Head Volume: 5.4cc
 P/N 109-11111-70-00 – Special.
 Carburetor Size: 18mm
 P/N 109-14101-70-00 – VM 18 SC Special.
 Ignition Timing: 2.0mm BTDC
 Spark Plug Heat Range: NGK B 9 HN

Special Parts:

Rod: Slotted, 2mm wide, 10mm long
 Wide Ratio Transmission.
 Expansion Chamber: P/N 109-14610-10-00
 Shift Lever: P/N 241-18111-00-93

JT 1 AND 2 SPECIAL

If rotary valve cover is modified to accept a larger carburetor, and an air cleaner is to be installed, the air cleaner should be of the wet filtron type. The air cleaner may be mounted to right side of engine by means of a rubber elbow.

If larger carburetor is used, the oil pump must be removed.

If oil pump is removed:

- Fuel-to-oil ratio of approximately 20:1 or 24:1 will be required.
- New throttle cable will be required.

JT 1 AND 2 SPECIAL

Port Diagram
 Cylinder Part No. 109-11311-70-00
 All Dimensions in Millimeters:
 Tolerance: $\pm 0.5\text{mm}$

CAUTION

When modifying rear booster port, be careful not to remove center bridge [A] since this would damage the piston ring.

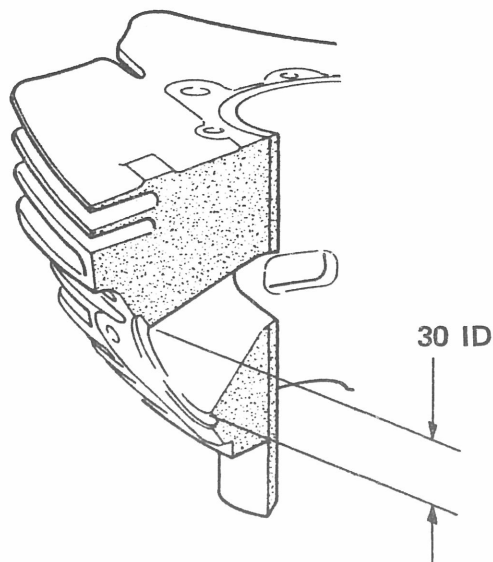
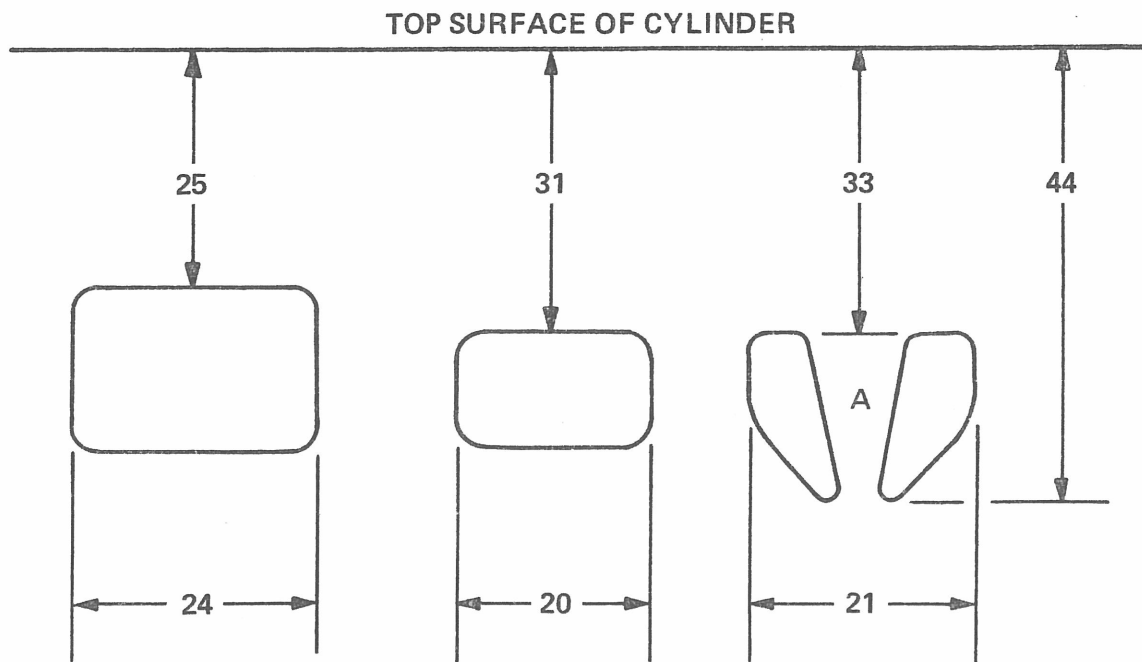

JT 1 AND 2 SPECIAL

Piston Diagram
Piston Part No. 109-11631-70-00
Piston Ring Part No. 109-11602-01-00
All Dimensions in Millimeters:
Tolerances: $\pm 0\text{mm}$

CAUTION

After cutting off a portion of the piston skirt, be sure to check for cracks along edge of skirt and around intake ports after each race.

If there is evidence of cracks or extreme wear, replace piston.

NOTE

When modifying piston skirt, be sure to modify the intake side only. This will change port timing.

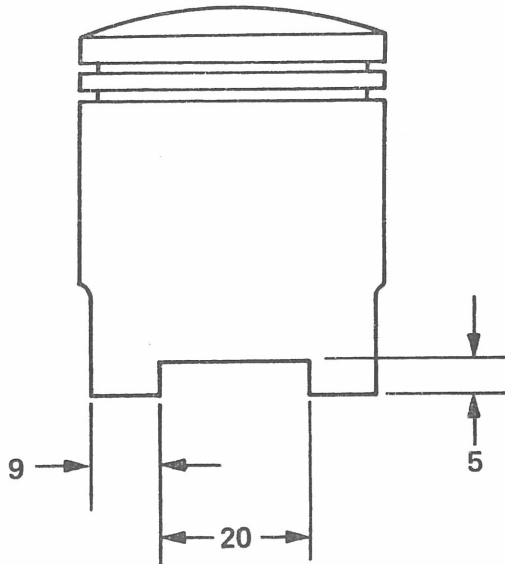

JT 1 AND 2 SPECIAL

Rotary Valve Cover.

If special type 18mm carburetor is to be used, rotary valve cover [1] must be modified.

If the special type 18mm carburetor cannot be obtained, do not modify rotary valve cover.

If rotary valve cover is modified, be sure intake port [4] on crankcase housing is also enlarged to 18mm ID.

The throat opening on the rotary valve cover is 16mm ID on outer end [3] and 17mm ID on inner end [2]. Modification of rotary valve cover consists of enlarging throat opening to 18mm ID.

There are two methods available for modifying rotary valve cover:

Method one does not allow cover to be returned to stock configuration.

Method One:

- Measure and cut 14mm from outer end of throat.
- Weld or braze 23mm wide and 44mm long tubular stock to rotary valve cover.
- Drill center of stock to 18mm ID.

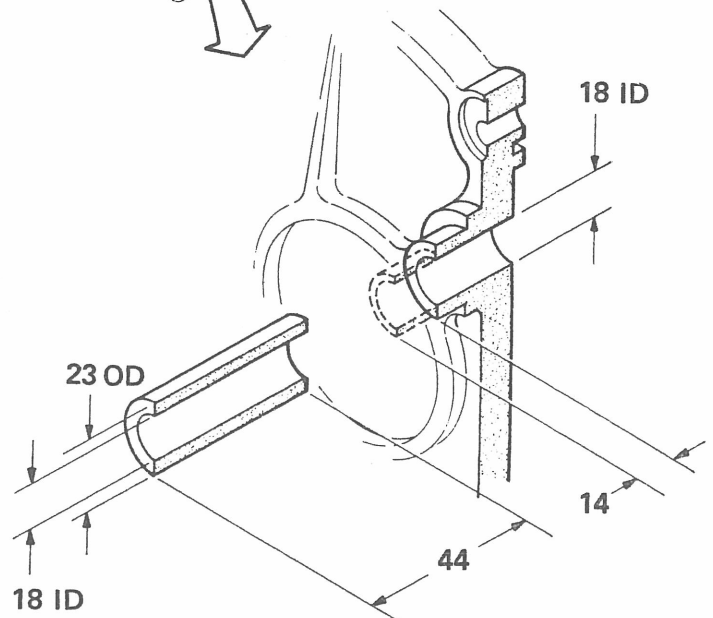
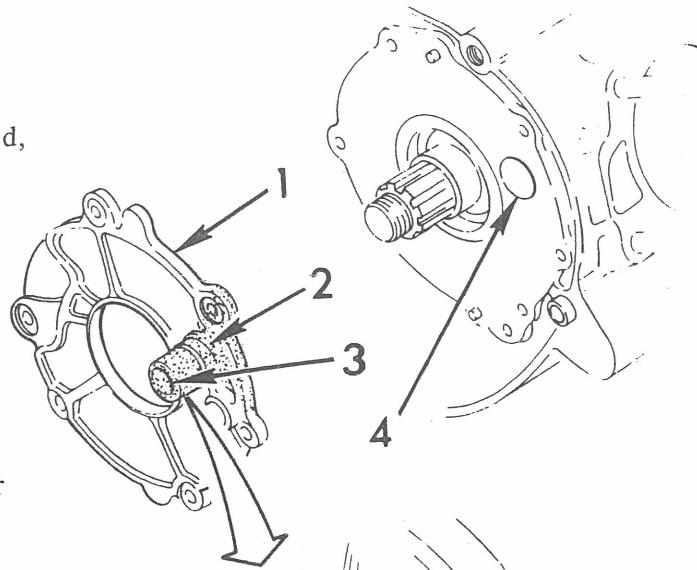

METHOD ONE

Method Two:

- Weld or braze 23mm wide and 30mm long tubular stock to outer end of throat.
- Using braze, fill in step area between rotary valve cover and stock.
- Drill center of stock to 18mm ID.

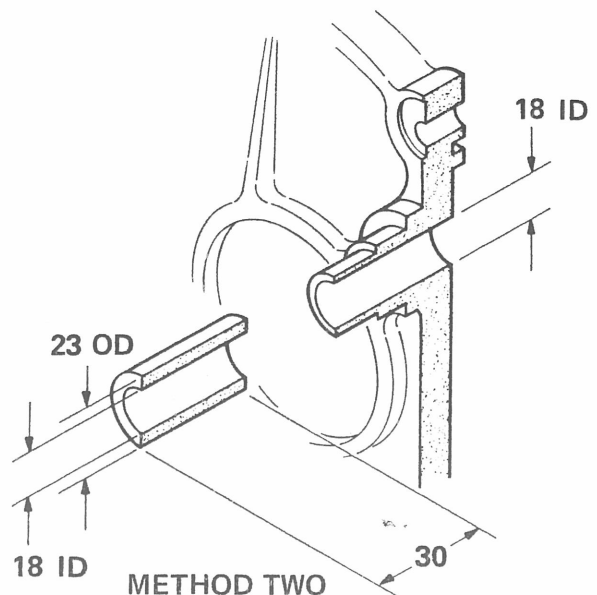

METHOD TWO

JT 1 AND 2 SPECIAL

Rotary Valve Diagram
Rotary Valve Part No. 257-13512-00-00

NOTE

The rotary valve diagram is drawn to actual size and may be used as a template when modifying valve.

When installing rotary valve:

- Be sure that piston is at bottom of stroke.
- Be sure that two indent marks [1] on valve are aligned with shear pin on crankshaft.

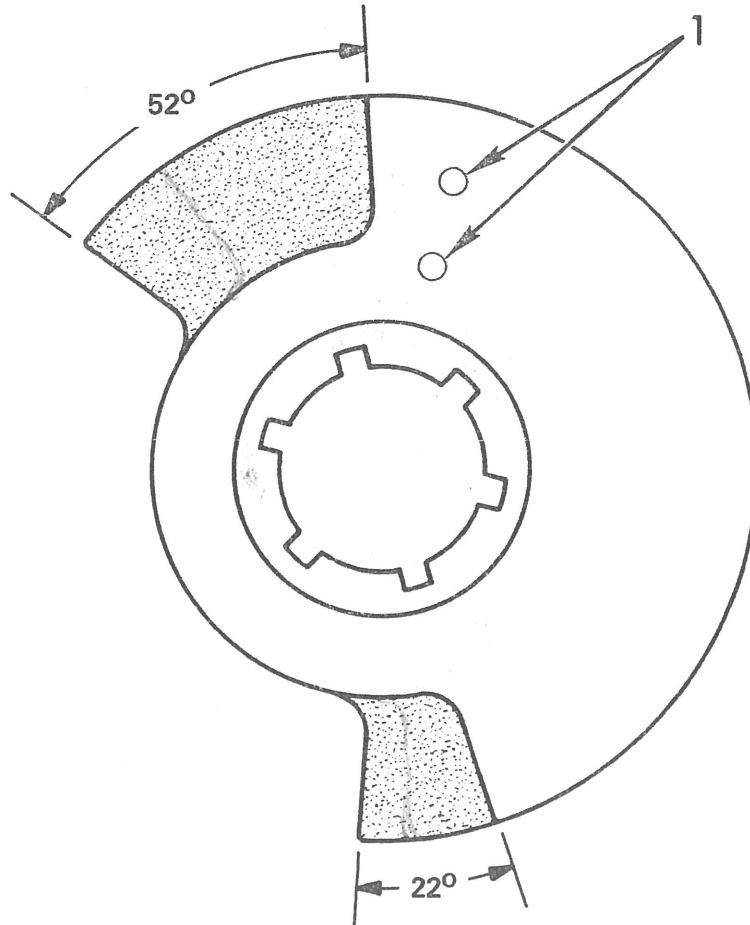

JT 1 AND 2 SPECIAL

Expansion Chamber P/N 109-14610-10-00

Material Thickness 1mm

All Dimensions in Millimeters:

Tolerance: $\pm 1.0\text{mm}$ **NOTE**

Modify stock expansion chamber as shown in sketch.

