



**YAMAHA**

**MOTORCYCLE**

[www.legends-yamaha-enduros.com](http://www.legends-yamaha-enduros.com)

**DT250B DT400B**  
**ASSEMBLY MANUAL**



90894-07404

## NOTICE

The service specifications given in this Assembly Manual are based on the model as manufactured when this model may require improvements, the service specifications may be subject to change in the future. If any change is introduced into the specifications or service procedures, Yamaha dealers will be notified through technical service information to be published by Yamaha. The assembly procedure is described in the order that the mechanic should follow, and the correct service tools should be used in the correct manner. Failure to do this may result in poor performance and danger to the rider.

[www.legends-yamaha-enduros.com](http://www.legends-yamaha-enduros.com)

YAMAHA DT250B/DT400B  
ASSEMBLY MANUAL  
JUNE, 1974  
SERVICE DEPARTMENT  
YAMAHA MOTOR CO., LTD.  
IWATA, JAPAN

## FOREWORD

This Assembly Manual contains the information required for the unpacking and assembly of Yamaha motorcycles so that the Yamaha serviceman can assemble the machine in the correct manner. To perform machine assembly, a basic knowledge of service and Yamaha machines is required. Therefore, all Yamaha dealers are urged to make a full study on the service of Yamaha motorcycles using the relevant service manuals.

[www.legends-yamaha-enduros.com](http://www.legends-yamaha-enduros.com)

YAMAHA MOTOR CO., LTD.  
SERVICE DEPARTMENT

## UNPACKING

### Procedure for unpacking

To remove the machine and parts packed in the cardboard crate, cut the vinyl bands around the box using a cutter or scissors. Next, remove the exterior carton by lifting it straight up.

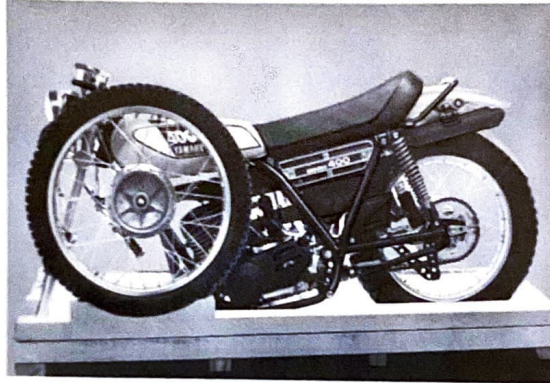

[www.legends-yamaha-enduros.com](http://www.legends-yamaha-enduros.com)

## PARTS CHECK LIST

Before starting the assembly, check for damaged or missing (listed below). Also check the machine for damage, scratches and other defects.

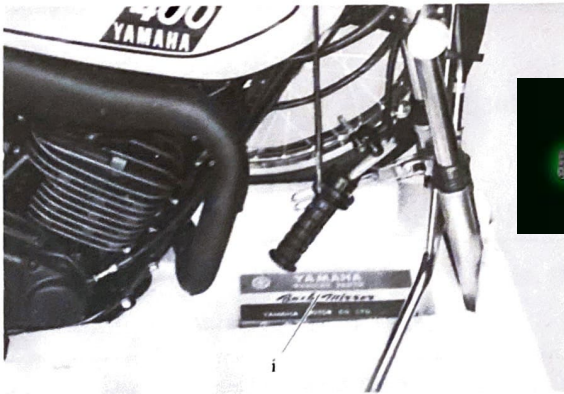
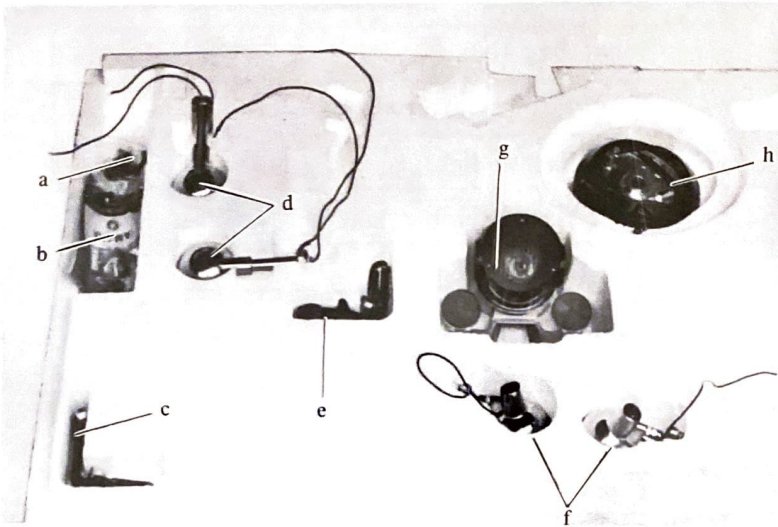

[www.legends-yamaha-enduros.com](http://www.legends-yamaha-enduros.com)

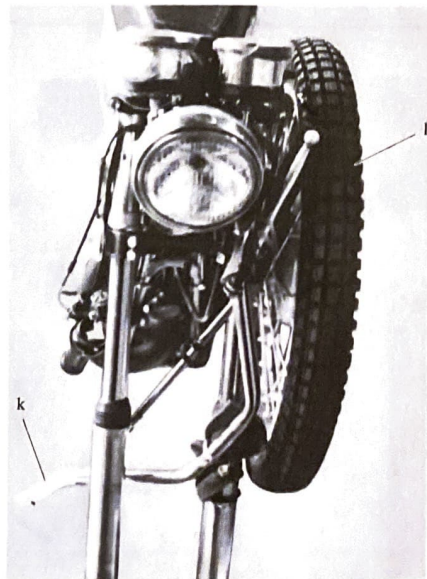
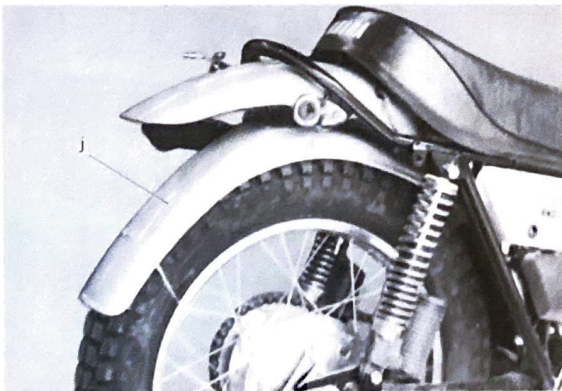



## CHECK LIST





Set position	Part Name	Q'ty
a	Vinyl bag (a)	1
b	Vinyl bag (b)	1
c	Foot rest assembly (left)	1
d	Rear flasher light	2
e	Foot rest assembly (right)	1
f	Front flasher light	2
g	Taillight assembly	1
h	Brake shoe plate assembly	1
i	Rear view mirror	1
j	Front fender	1
k	Handle bar assembly	1
l	Front wheel	1



### Details of Parts in the vinyl bag (a)

No.	Photo	Part Name	Q'ty	Remarks
a-1		Handle upper holder	2	For handlebar
a-2		Handle bar securing bolt (8mm X 31mm)	4	
a-3		Spring washer (8 mm)	4	

Details of Parts in the vinyl bag (b)

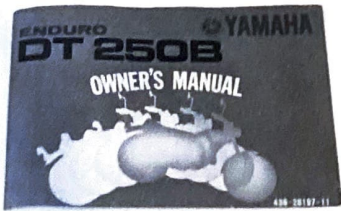
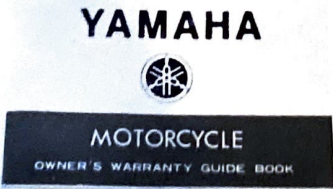
No.	Photo	Part Name	Q'ty	Remarks
b-1		Front fender damper	8	For front fender
b-2		Front fender collar	4	
b-3		Hexagon bolt (6mm X 25mm)	4	
b-4		Spring washer (6mm)	4	
b-5		Plain washer (6mm)	4	
b-6		Special washer (6mm)	2	
b-7		Owner's Manual	1	
b-8		Warranty guide book	1	
b-9		Cotter pin	1	For front wheel axle

## SET-UP PROCEDURES

1. Remove the front fender held between the rear tire and the rear fender. Next, remove the front wheel.

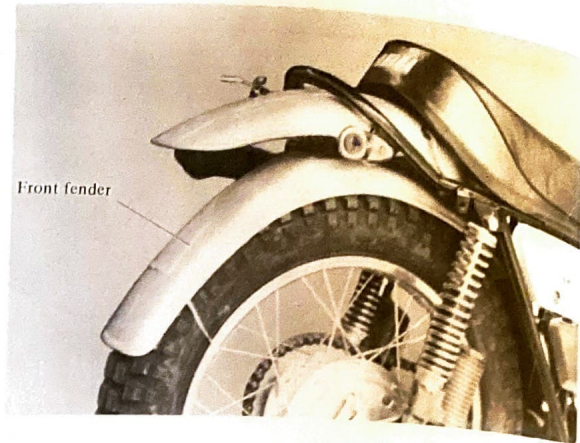

2. Lift up the machine, and remove the rear wheel section from the foam styrol base. Then take out the machine.
3. To install the front fender and front wheel, place a proper-size wooden box or a wooden block under the engine to keep the front of the machine raised off the floor. Take care so that the machine does not fall over.

4. Insert the front fender between the front fork legs, and secure the fender using the specified number of spring washers, fender collars, plain washers, dampers and special washers.

Bolts: 6 mm X 4 pcs. (b-3)

Spring washer: 6 mm X 4 pcs. (b-4)

Plain washer: 6 mm X 4 pcs. (b-5)

Dampers: 8 pcs. (b-1)

Special washer: 6 mm X 2 pcs. (b-6)

Fender collar: 4 pcs. (b-2)

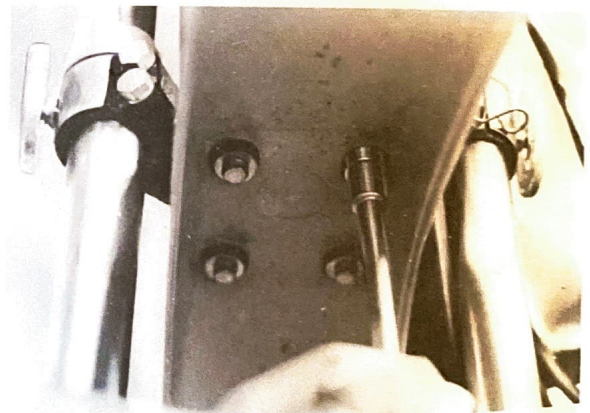

Tightening torque:

0.35 – 0.55 m·kg (30 – 48 in·lb.)

### Note:

- a. The front fender should be installed with the arrow mark in the center facing forward.
- b. The special washers should be installed to rear two bolts of fender.

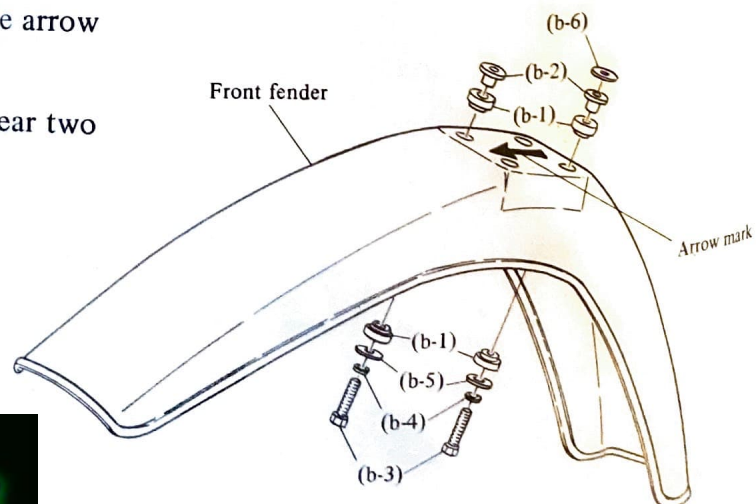



5. Apply a light coat of grease to the speedometer drive gear and oil seal.

**Caution:**

Take care not to put grease on the brake linings or inner surface of the brake drum.

If you do so, clean using a rag dampened with a solvent. Foreign material on braking surface can cause impaired braking action.

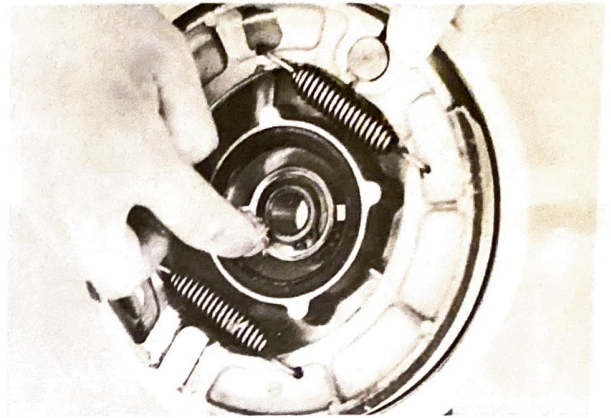

6. Remove the front wheel axle nut and plain washer, and loosen the nuts securing the axle holder. Then remove the wheel axle, wheel axle collar, hub dust cover and distance collar.

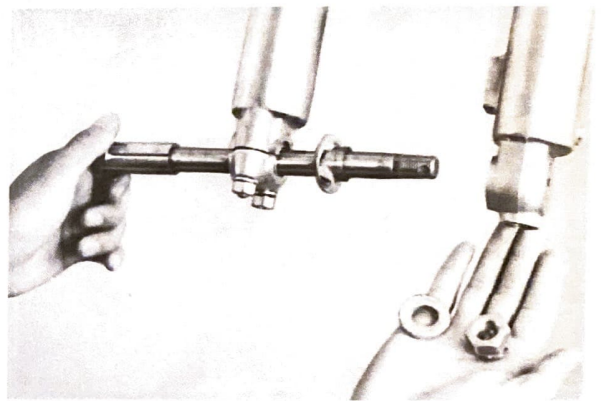

7. Install the wheel axle collar in the wheel hub on the right side of the front wheel.

**Note:**

To avoid damaging the oil seal lip, apply a light coat of lithium base grease to the oil seal lip and axle collar.

If the collar is dirty, clean with a rag.

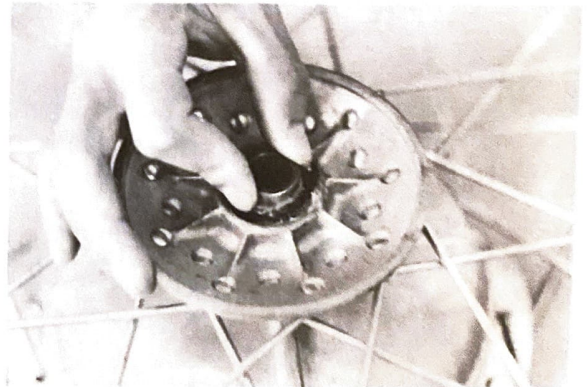

8. Install the brake shoe plate assembly in the front wheel hub.

- a) Clean the inner surface of the front wheel hub with a clean cloth.

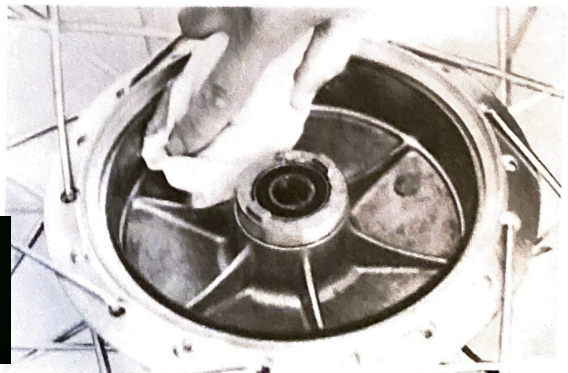

- b) Make sure the brake shoes and springs are correctly installed in the shoe plate assembly.  
If any one of them is out of place, correct per the photo.

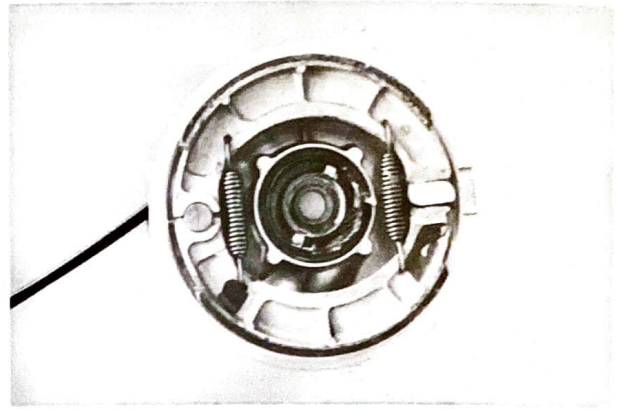

- c) Install the brake shoe plate assembly in the wheel hub.

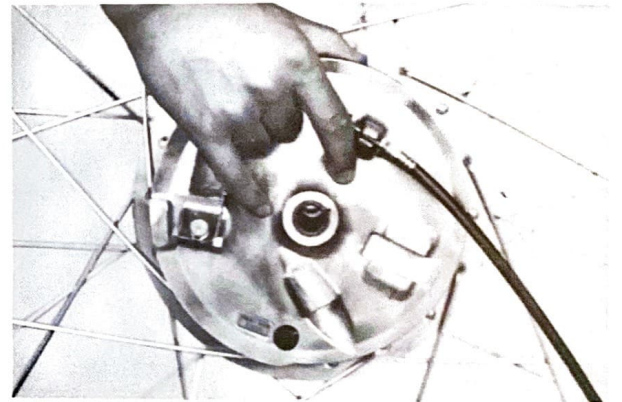

9. Install the front wheel on the front forks.

- a) Insert the front wheel between the front fork legs so that the stopper (projection) on the front fork end correctly engages the slot in the brake shoe plate.

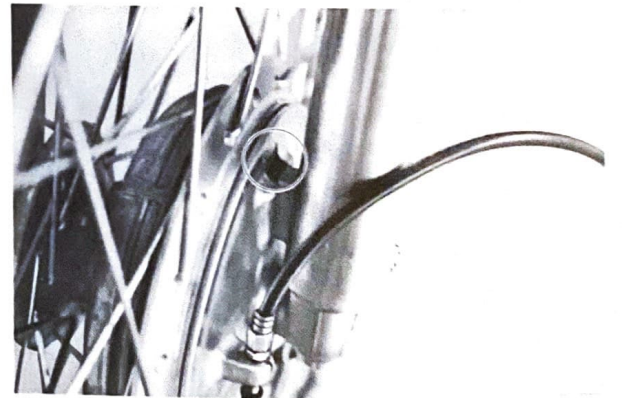

- b) Install the distance collar on the wheel axle. Then, insert the axle, mount the plain washer on the axle, and install the axle nut.
- c) Lightly tighten the axle holder nuts so that the axle does not turn while the axle nut is tightened.

d) Torque-the axle nut to specification.

Tightening torque:  
7.0 – 10.0 m-k<sub>g</sub> (50 – 72 ft-lb)

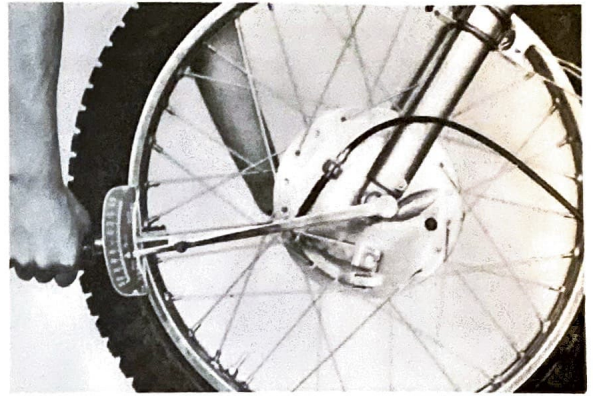

e) Torque the axle holder nuts to specification.

Tightening torque:  
0.8 – 1.25 m-k<sub>g</sub> (70 – 110 in-lbs)

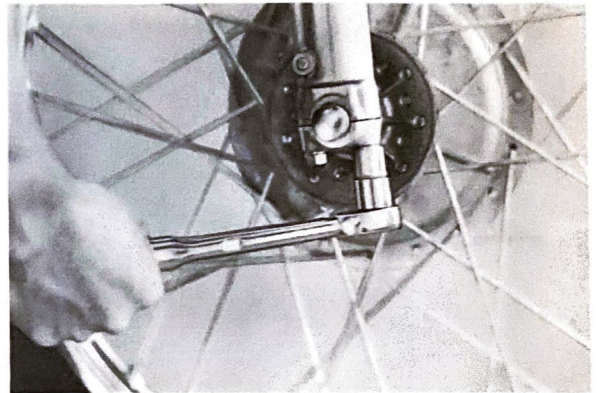

**Caution:**

Tighten axle holder nuts in stages and maintain an equal gap on each side.

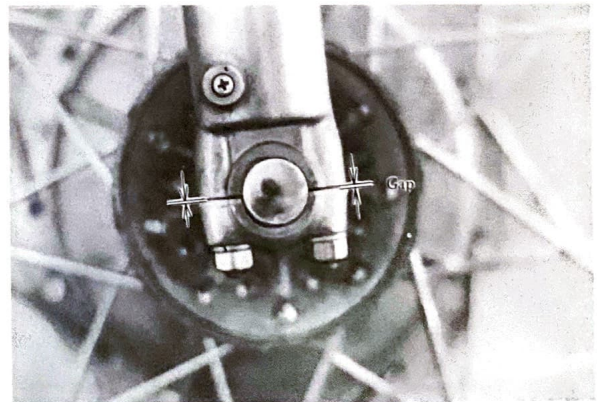

f) Lock the nut with the cotter pin. The pin should be inserted downward, and the pin ends should be bent.

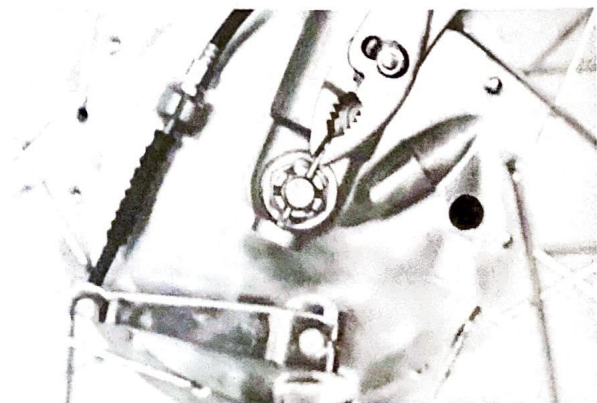

10. Connect the speedometer cable to the front wheel hub gear unit. Insert the cable end into the gear unit, fit the circlip in the groove on the wheel hub side, and lock the cable. (The circlip is already attached to the cable.)

\*For detailed cable routing, refer to illustration.

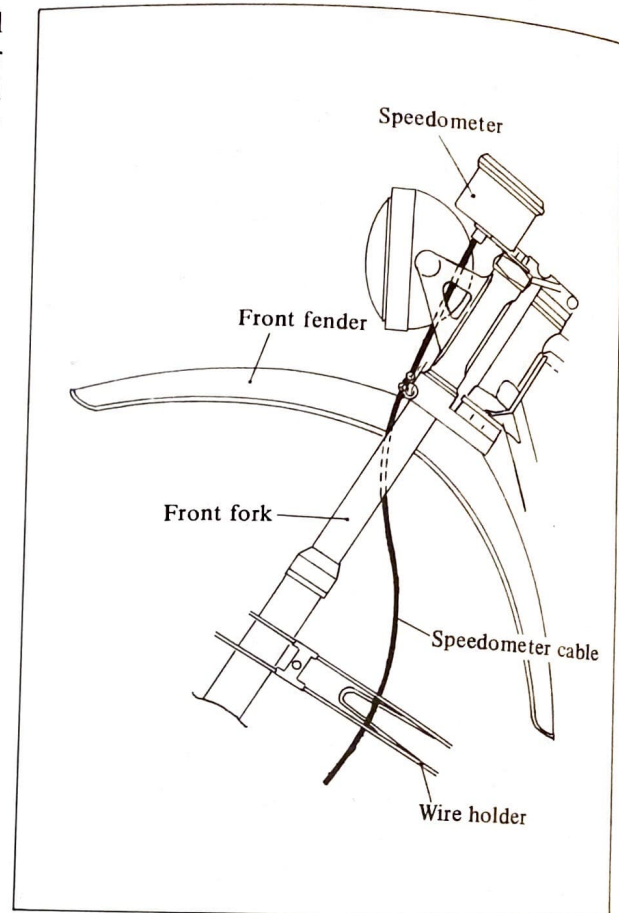

11. Insert the front brake lever holder into the right of the handlebar.

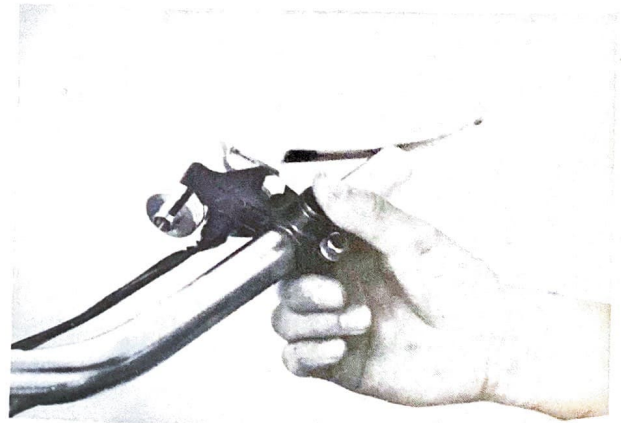

12. Grease the right end of the handlebar and the throttle grip housing, and install the throttle grip.

**Caution:**

Make certain throttle grip rotates on the handlebar freely, without binding. If not, normal throttle return will be impaired.

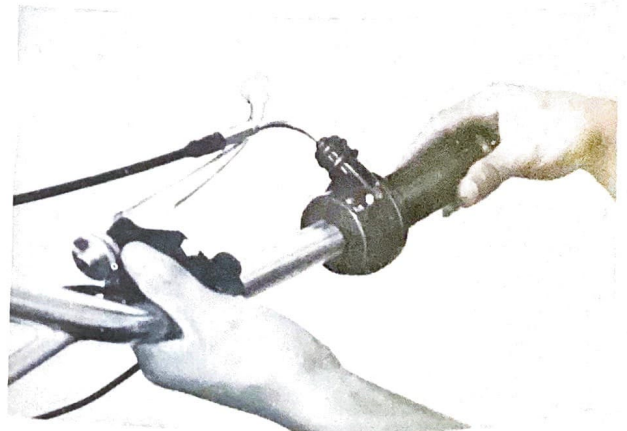

13. Handlebar installation  
 Using the bolts, spring washers and handle upper holder contained in the vinyl bag (a), install the handle bar.

- Bolts: 8 mm X 4 pcs. (a-2)
- Spring washers: 8 mm X 4 pcs. (a-3)
- Handle upper holder: 2 pcs. (a-1)

Tightening torque:  
 0.8 – 1.25 m·kg (70 – 110 in·lbs)

**Caution:**  
 Tighten bolts in stages and maintain an equal gap on each side of each holder.

14. Slip the throttle grip over the handlebar to the limit and slide it back about 5 mm (0.2 in.), and assemble the throttle housing using the screws provided.

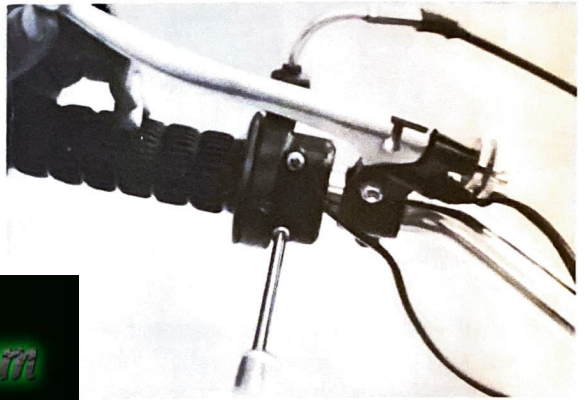
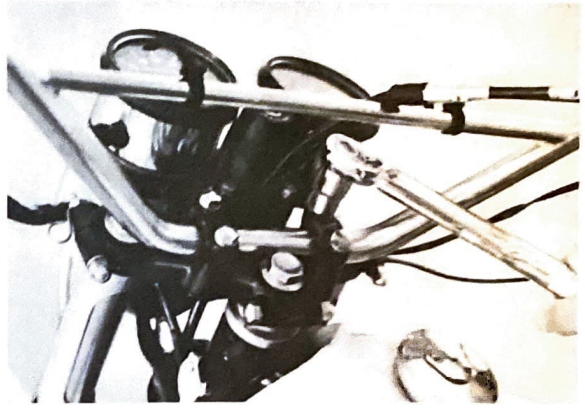

\*For detailed cable routing refer to illustration.

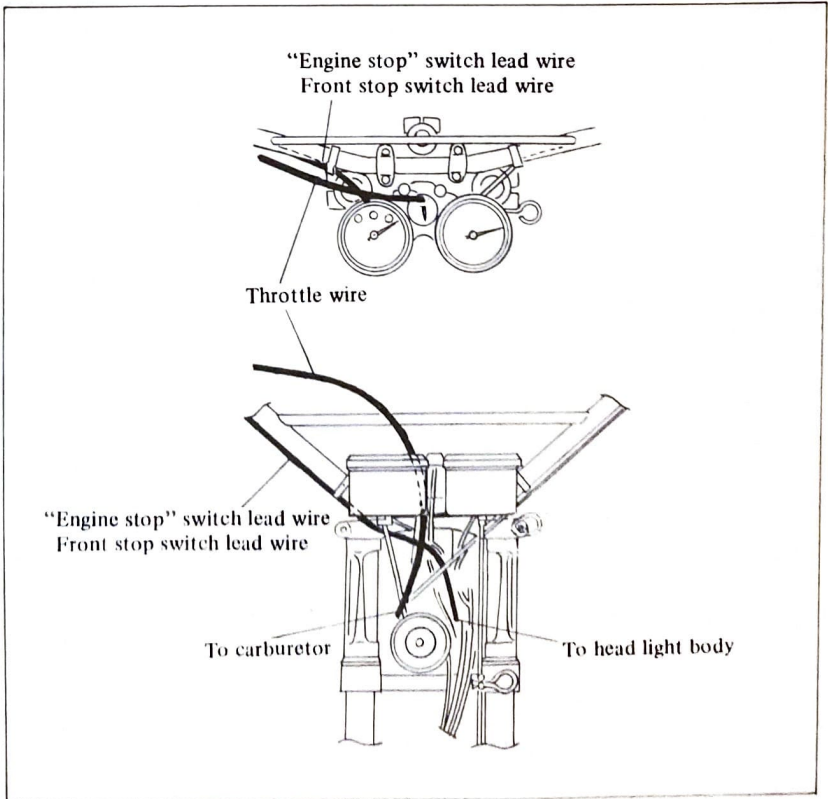

15. Check to see that the throttle grip moves smoothly.
16. Secure the brake lever holder with the 6 mm hexagon bolt and spring washer.

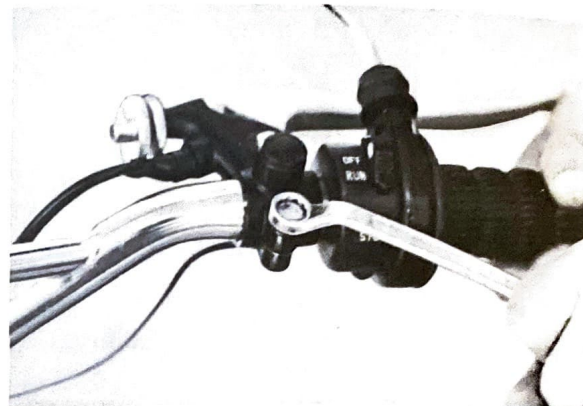

17. Brake wire and clutch wire installation.

- a) Screw in the cable length adjusters on the brake shoe plate (brake wire).
- b) Fully loosen the lever adjuster lock nut, and screw in the adjuster until tight. Next, align the slit in the adjuster and adjuster lock nut with the slit in the lever holder.

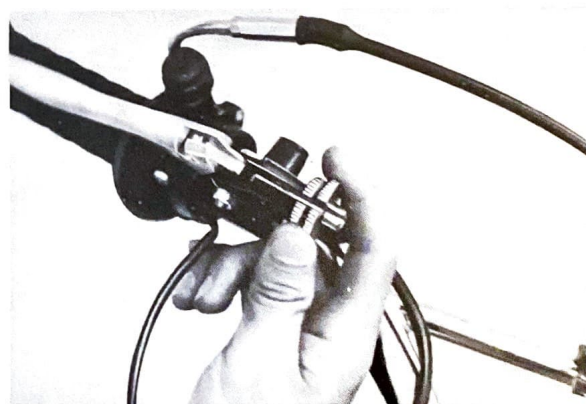

- c) Insert the wire end into the lever hole, and hook the outer cable end onto the adjuster lock nut, then squeeze the lever. Next, while pulling the outer cable in the direction opposite to the lever, release the lever quickly. While releasing it, seat the outer cable into the adjuster.

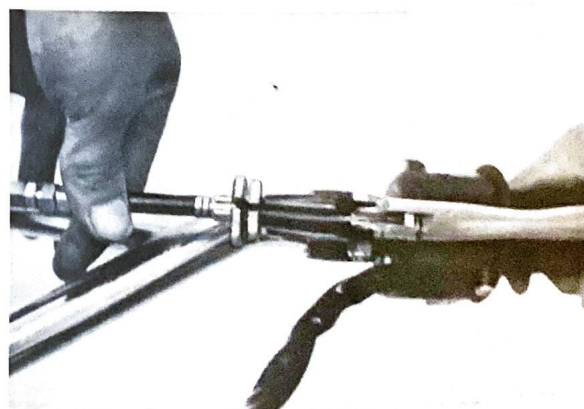

**Caution:**

Proper cable and wire routing is essential to insure safe vehicle operation.  
For details of the cable routing. Refer to illustration.

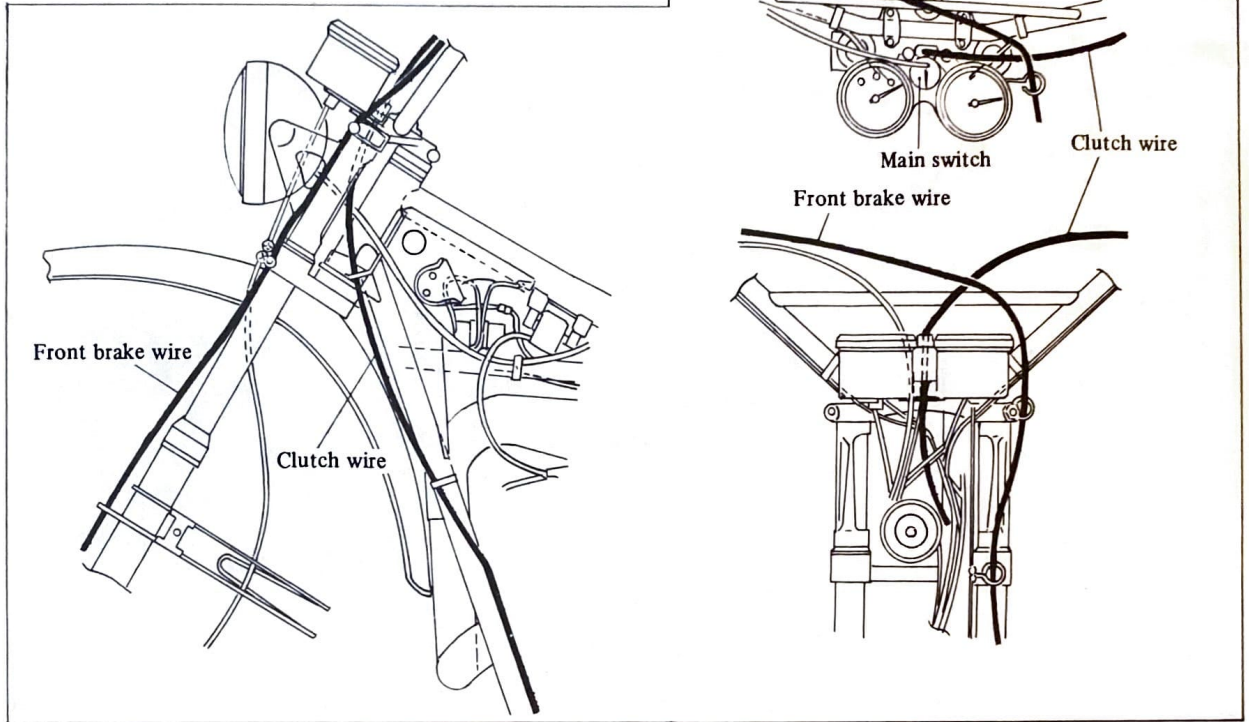

18. Install the rear view mirror (i) on the clutch lever holder (lefthand side), and tighten the lock nut.

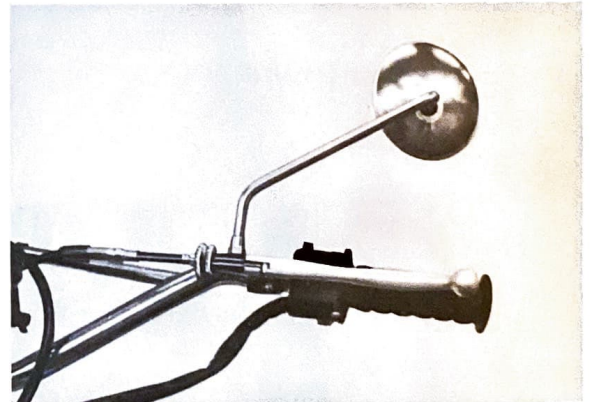

19. Remove the Phillips head screw from the bottom of the headlight body. Insert a slotted head screwdriver between the headlight body and the headlight rim, pry out the lens assembly.

**Note:**

During the operation, care should be taken not to scratch the headlight body and lens rim. Also take care so that the screw is not lost.

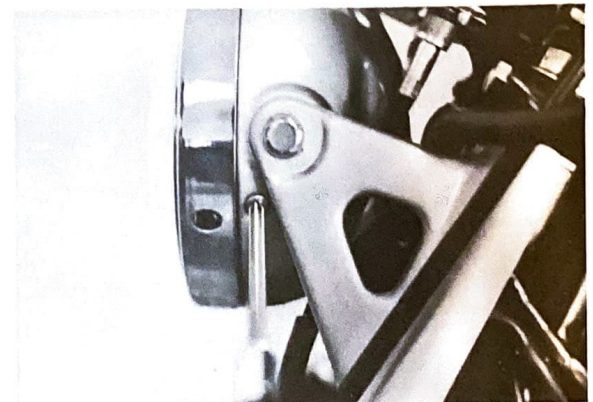

20. Front flasher light installation.

a) Install the flasher light (A dark brown marker is attached) on the left side handle bar. Next, install the other flasher light (a dark green marker is attached) on the right side handlebar.

b) Connect flasher light lead wires inside the headlight body. The wires of identical colors should be connected.

( Left front flasherlight lead wire (Dark brown marker) – wire harness lead wire (Dark brown).

( Right front flasherlight lead wire (Dark green marker) – wire harness lead wire (Dark green)

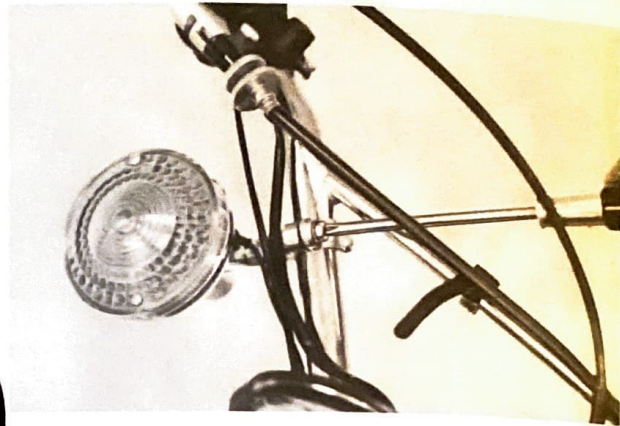

21. When installing the headlight lens assembly, care should be used so that wires are not pinched. Secure the headlight assembly in place with the Phillips head screw.



22. Hold the all lead wire to the handlebar (left and right side) with a rubber band.





23. Remove the footrest lock bolts and special nuts from footrests and footrest shafts. Align the punch mark on the footrest shaft and insert the footrests, both right and left. Next, lock the right and left footrests with special nuts, and secure with the lock bolts.

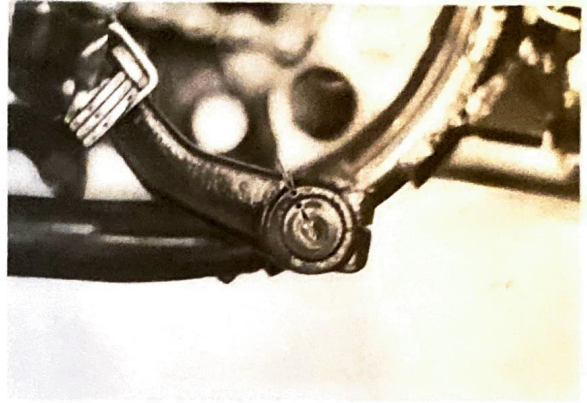

**Tightening torque:**

Special nut	3.0 – 4.8 m-kg (26 – 46 ft-lbs)
Footrest lock bolt	0.8 – 1.25 m-kg (70 – 110 in-lbs)

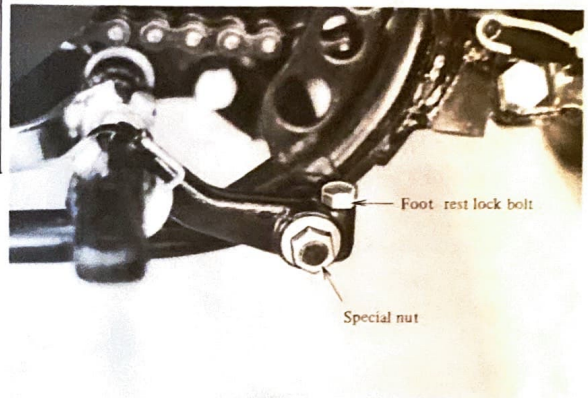

**24. Taillight assembly installation**

- a) Remove the taillight assembly holding bolts, washers and nuts from the taillight license bracket.
- b) Connect the taillight assembly lead wire to the wire harness, and lock it with the hook. (The wires of identical color should be connected.)

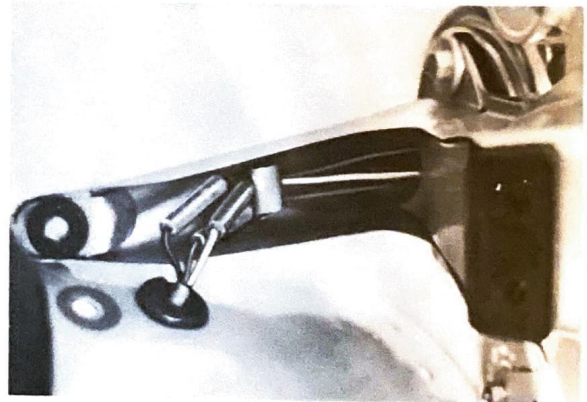

- c) Secure the front part of license bracket using the bolt, washer with cover, fender mounting collar, spring washers and crown nut.

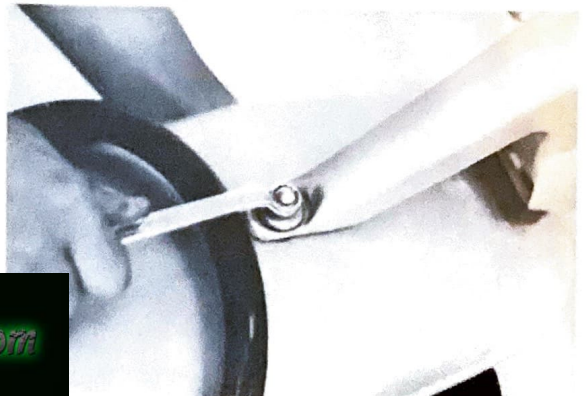

- d) Secure the rear part of the license bracket using two shoulder bolts, special washers, spring washers and nuts.

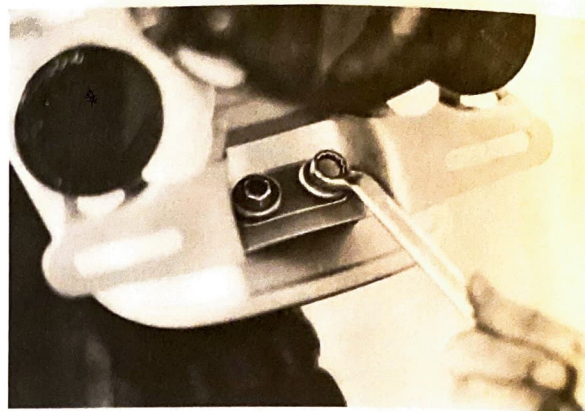

## 25. Rear flasher light installation

- a) Install the flasher light, with the dark brown color marker on the left side. Next, install the other flasher light (a dark green marker is attached) on the right side.
- b) When installing the flasher light, install the ground wire between the special washer and the nut, and lock it as illustrated.

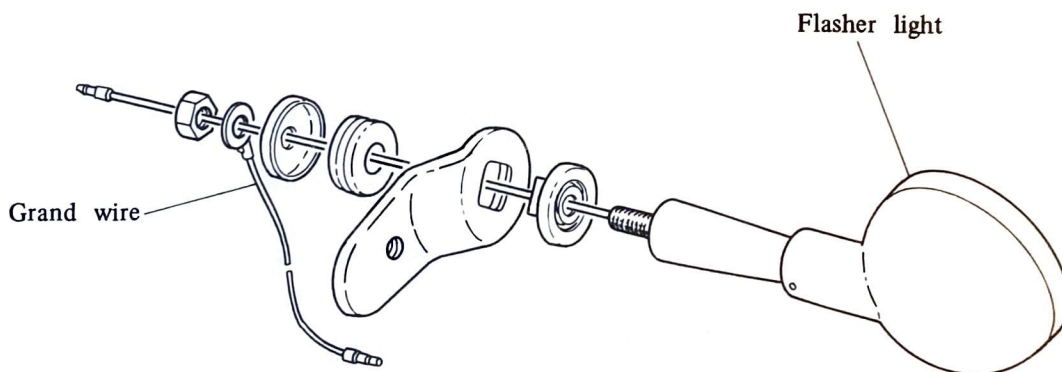

- c) Connect the flasher light lead wires to the wires inside the wire connector cover. The wires of identical colors should be connected.



- d) After connecting wire, secure the lead wires with the clamp located on the rear fender.

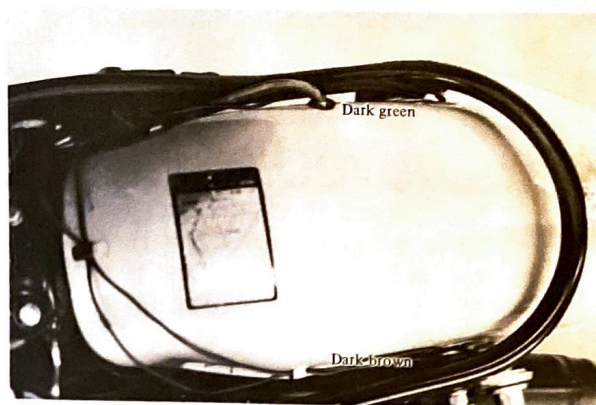

## 26. Battery

- a) When filled with diluted sulfuric acid electrolyte, this battery can be put into use immediately. That is, it is a dry-charged battery. It is advisable, however, that the battery be charged as much as possible before using for the first time for maximum performance. This initial charge will prolong the life of the battery.  
 Charging current: 0.4 A  
 Charging hours: 10 hours.

- b) How to prepare diluted sulfuric acid  
 The diluted sulfuric acid can be prepared by adding sulfuric acid to distilled water at a specific mixing ratio.

Specific gravity at 20°C	Ratio of distilled water to sulfuric acid
1.25	3.4
1.26	3.2
1.27	3.0
1.28	2.8
1.29	2.7
1.30	2.6

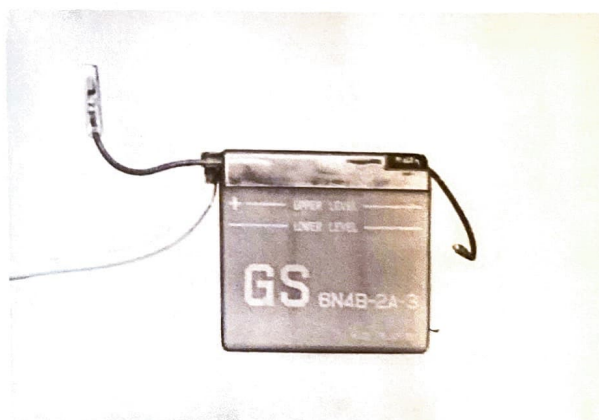

Pour distilled water into a glass container, and add sulfuric acid while stirring with a glass stick. Adding the acid will generate heat, and therefore, care should be taken so that heat does not rise excessively.

### Caution:

Never attempt to add distilled water to sulfuric acid.

c) Filling the battery with diluted sulfuric acid

- 1) Remove all filter caps from the battery, and cut the breather pipe end at the same time.
- 2) Cool the diluted sulfuric acid down to below 30°C (86°F).
- 3) Pour diluted sulfuric acid into each cell little by little up to the upper level line, and leave it for a while. When the battery fluid permeates the plates and separators, the fluid level begins to lower. Add diluted sulfuric acid again.
- 4) Charge the battery as required, and measure the specific gravity of the fluid.
- 5) Install the filler caps, and thoroughly wipe off the fluid around the filler caps.

27. Battery installation

- a) Make sure the main switch is turned off, and install the battery in the battery box. (Secure the battery with a band.) Connect the positive lead wire first, and then connect the negative lead wire.
- b) Clamp the lead wire.
- c) The breather pipe should be layout as illustrated.

**Note:**

Rout the breather pipe outlet down and away from any part of the machine.

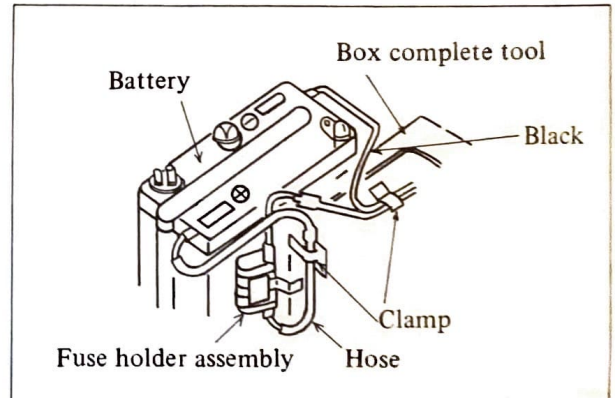
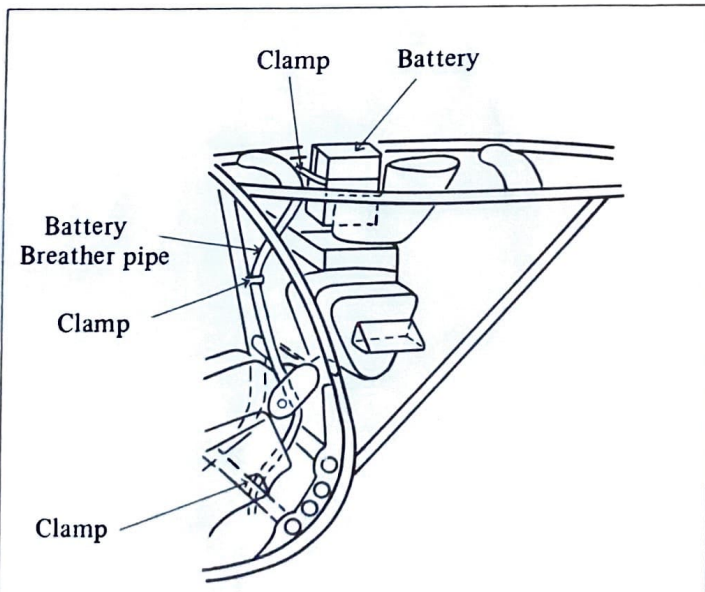
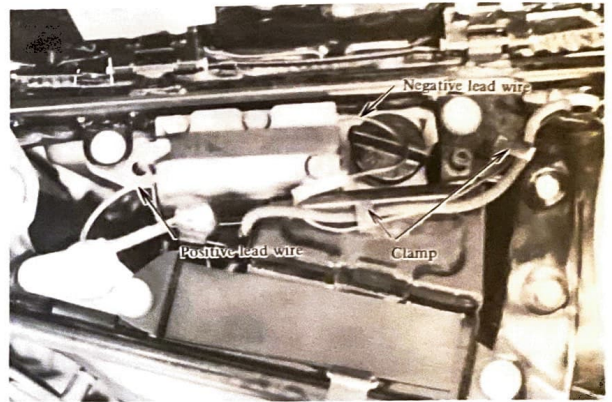

## Inspections

After all packed parts are installed, check to see that all these parts and other parts (mounted or installed at the Yamaha factory) are correctly mounted or installed, or tightened to specification. This check-up should be started with the front of the machine.

### Item

Front wheel spokes .....	Tension
Front wheel rim .....	Hopping, deflection
Front wheel tire .....	Tire pressure
Front wheel axle nut .....	Cotter pin, tightening torque
Front wheel axle holder lock nuts .....	Tightening torque
Steering head lock nut .....	Tightening torque
Handlebar holder .....	Tightening torque
Clutch lever holder .....	Tightening torque
Brake lever holder .....	Tightening torque
Front flasher light .....	Mounting, wiring
Throttle housing .....	Position, operation, tightness
Engine mounting bolts .....	Tightening torque
Carburetor joint(s) .....	Tightness
Footrests .....	Position, tightening torque
Change pedal .....	Position, looseness, operation
Brake pedal .....	Position, looseness, operation
Seat .....	Mounting, clevis pin, clips
Fuel tank .....	Mounting
Fuel pipe .....	Connection
Battery .....	Mounting, fluid level, wiring
Rear fender .....	Mounting
Taillight .....	Mounting, wiring
Rear flasher light .....	Mounting, wiring
Rear cushion .....	Mounting, tightening torque
Rear swing arm pivot shaft .....	Tightening torque
Rear axle nut .....	Cotter pin, tightening torque
Chain puller .....	Lock nut
Rear wheel .....	Spoke tension
Rear wheel rim .....	Hopping, deflection
Rear wheel tire .....	Tire pressure
Transmission oil .....	Oil level
Engine oil .....	Oil level

**THIS CONCLUDES THE ASSEMBLY PORTION HOWEVER, THE UNIT MUST STILL BE "SET-UP" FOR DELIVERY TO THE CUSTOMER.**

For specifications regarding ignition timing, carburetor adjustment, tire pressures, engine oil type and quantity, etc.. Refer to appropriate section of DT250B/400B service manual.

[www.legends-yamaha-enduros.com](http://www.legends-yamaha-enduros.com)

**Part A View**

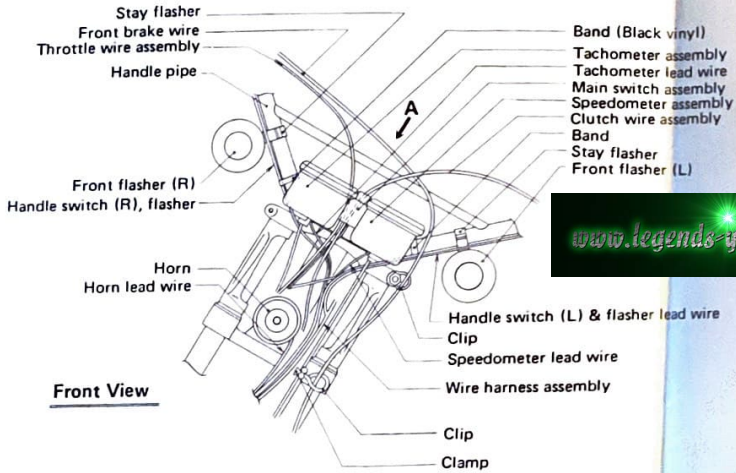
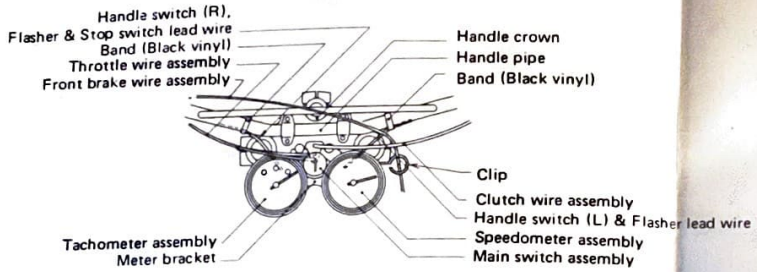

**Front View**

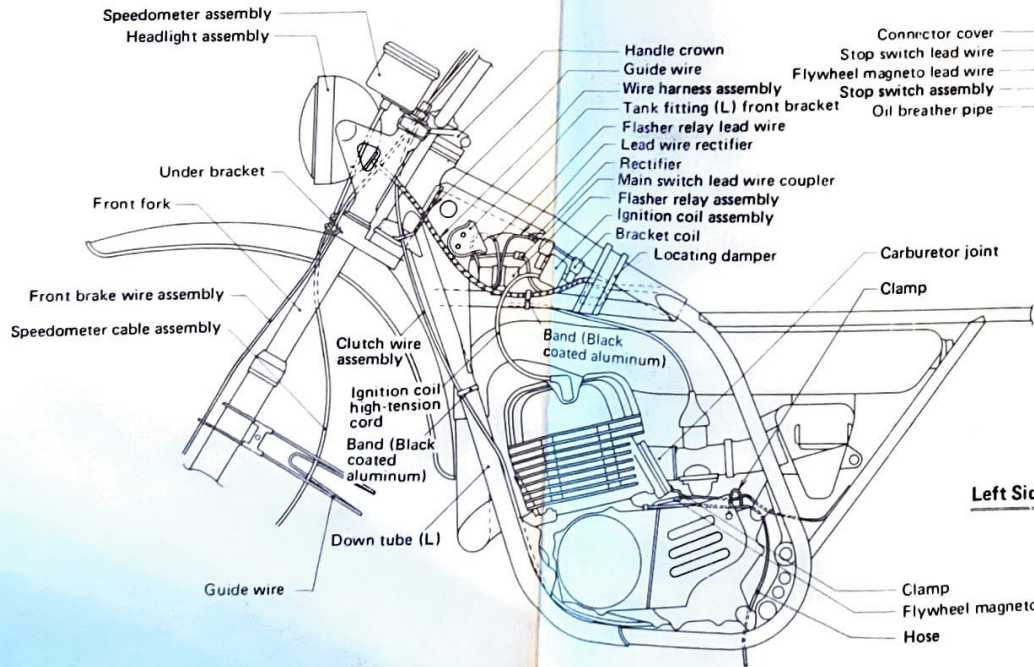

**Left Side View**

**CABLE ROUTING DIAGRAMS**

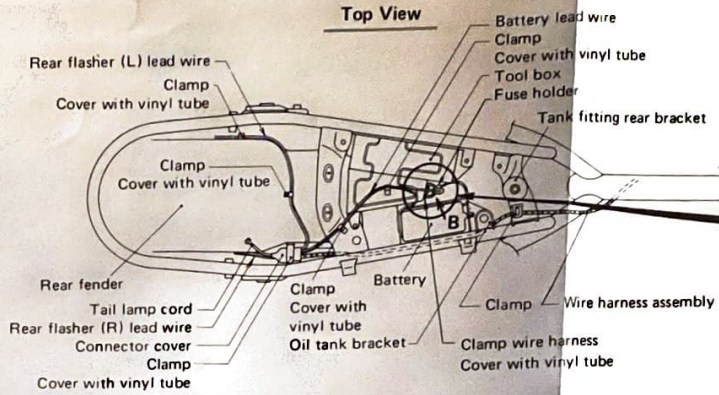

**Top View**

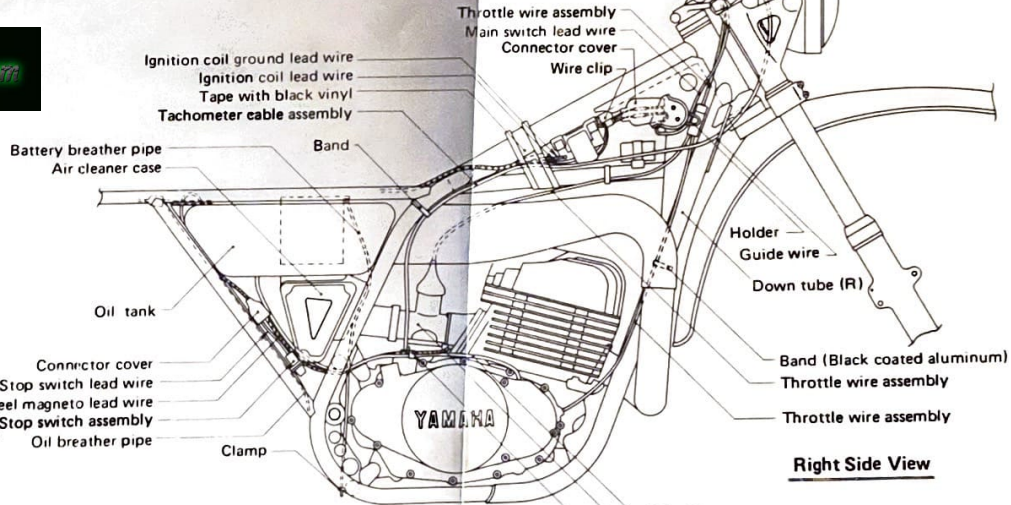

**Right Side View**

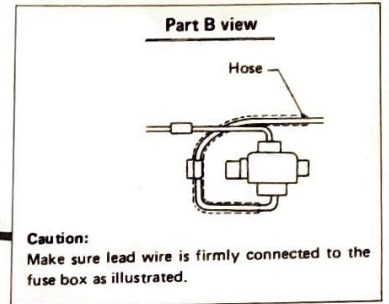

**Part B view**

Caution: Make sure lead wire is firmly connected to the fuse box as illustrated.



\* Note: Connect the stop switch lead wire to the harness of lead wire in the headlight body.



SINCE 1887

**YAMAHA MOTOR CO.,LTD.**

IWATA, JAPAN

[www.legends-yamaha-enduros.com](http://www.legends-yamaha-enduros.com)

LIT-11664-00-04