



YAMAHA

GENUINE

**PARTS CATALOGUE
MOTORCYCLE**

www.legends-yamaha-enduros.com

CRANKCASE - CYLINDER

Ref. No.	Part Number	Description	Qty	Remarks
	(2A7-00000-20-00)	GSKTKT DT175E/F		SEE GRID G1 FOR COMPONENTS
1	(2A6-15111-02-00)	CRANKCASE 1	1	
2	2A6-15121-01-00	CRANKCASE 2	1	
3	99510-20020-00	PIN, DOWEL	1	
4	99530-10014-00	PIN, DOWEL	1	
5	98580-06550-00	SCREW PAN HEAD (92503-06050)	5	
6	92580-06560-00	SCREW PAN HEAD	3	
7	98501-06070-00	SCREW, PAN HEAD	3	
8	98501-06075-00	SCREW, PAN HEAD	1	
9	90430-12207-00	GASKET	1	
10	90340-12005-00	PLUG, DRAIN	1	
11	95611-10630-00	BOLT, STUD	2	
12	95611-10640-00	BOLT, STUD	2	
13	90179-10201-00	NUT	4	
14	99530-14016-00	PIN, DOWEL	2	
15	304-15128-00-00	HOLDER	1	
16	92501-08010-00	SCREW, PAN HEAD	1	
17	90116-08104-00	BOLT, STUD	6	
18	18G-11351-01-00	GASKET, CYLINDER	1	
19	2A7-11311-00-00	CYLINDER 1	1	
20	1W2-11181-00-00	GASKET, CYLINDER HEAD 1	1	
21	∅2N-51111-10-0-	UNAVAILABLE IN PRICE BOOK	1	
22	90201-08100-00	WASHER, PLATE	6	
23	95333-08600-00	NUT	6	
24	NGK-B8ES0-00-00	PLUG, SPARK (NGK B8ES)	1	
25	2N4-15371-00-00	BREATHER	1	
26	90445-07340-00	HOSE	1	

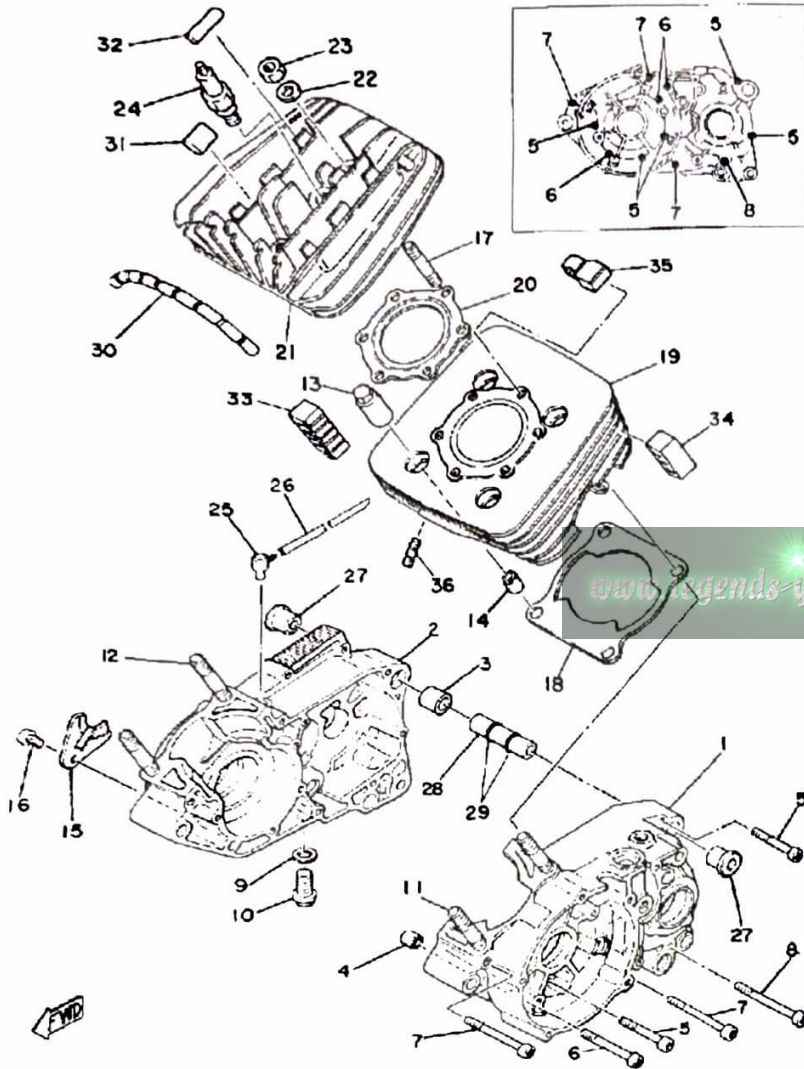

CONTINUED ON NEXT FRAME ►

CRANKCASE - CYLINDER

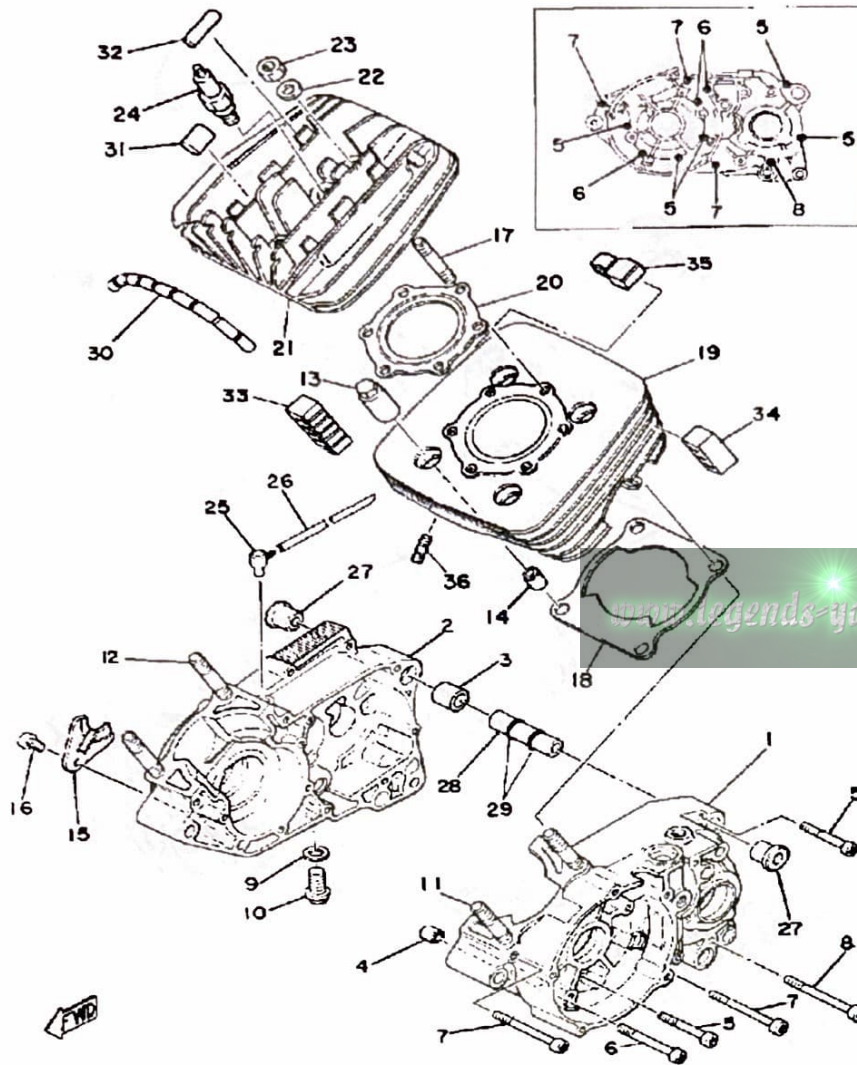

Ref. No.	Part Number	Description	Qty	Remarks
27	328-15316-00-00	DAMPER, ENG MOUNT 1 (328-15316-00)	2	
28	401-15317-00-00	SPACER, ENG MOUNT	1	
29	93210-11073-00	O-RING	2	
30	2A6-11161-00-00	ABSORBER 1	1	
31	2A6-11162-00-00	ABSORBER 2	1	
32	3LN-2139U-00-00	ABSORBER 2	2	
33	2A6-11127-00-00	ABSORBER 3	2	
34	2A6-11127-00-00	ABSORBER 3	2	
35	2A6-11129-00-00	ABSORBER 5	1	
36	(2A7-00000-20-00)	GSKTKT DT175E/F		SEE GRID G-1 FOR COMPONENTS
	90116-06016-00	BOLT, STUD	2	

CRANK - PISTON

Ref. No.	Part Number	Description	Qty	Remarks
1	2N4-11400-00-00	CRANKSHAFT ASSEMBLY	1	
2	1W1-11412-01-00	. CRANK 1	1	
3	1W1-11422-01-00	. CRANK 2	1	
4	25V-11651-00-00	. ROD, CONNECTING 1	1	
5	3M5-11681-00-00	. PIN, CRANK 1	1	
6	93310-42277-00	. BEARING, CYLINDER.#10 (93310-42231)	1	
7	90209-22248-00	. WASHER	2	
8	2N5-11631-00-96	PISTON STD (2A7-11631-00-96)	1	
	2N5-11635-00-00	PISTON 1 O/S 0.25 (2A7-11635-00)	1	AP
	2N5-11636-00-00	PISTON 2 O/S 0.50 (2A7-11636-00)	1	AP
	2N5-11637-00-00	PISTON 3 O/S 0.75 (2A7-11637-00)	1	AP
	2N5-11638-00-00	PISTON 4 O/S 1.00 (2A7-11638-00)	1	AP
9	2N5-11610-00-00	PISTON RINGSET STD	1	STD
	2N5-11610-10-00	PISTON RINGSET 1ST	1	AP
	2N5-11610-20-00	PISTON RINGSET 2ND	1	AP
	2N5-11610-30-00	PISTON RINGSET 3RD	1	AP
	2N5-11610-40-00	PISTON RINGSET 4TH	1	AP
10	93310-216E1-00	BEARING	1	
11	251-11633-00-00	PIN, PISTON	1	
12	93450-17044-00	CIRCLIP	2	
13	93306-20529-00	BEARING (B6205C4)	1	
14	93102-25061-00	OIL SEAL, SD-TYPE	1	
15	90201-12593-00	WASHER, PLATE	1	
16	92901-12100-00	WASHER, SPRING	1	
17	90170-12347-00	NUT, HEXAGON	1	

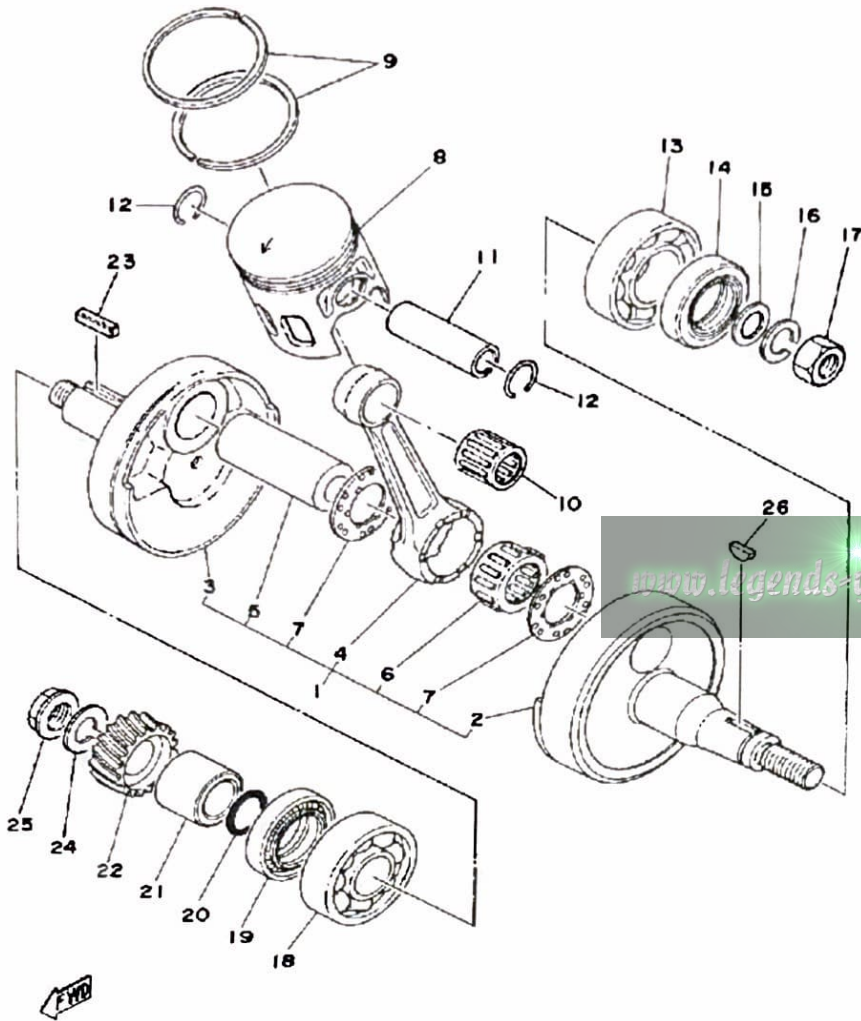

CONTINUED ON NEXT FRAME ➤

CRANK - PISTON

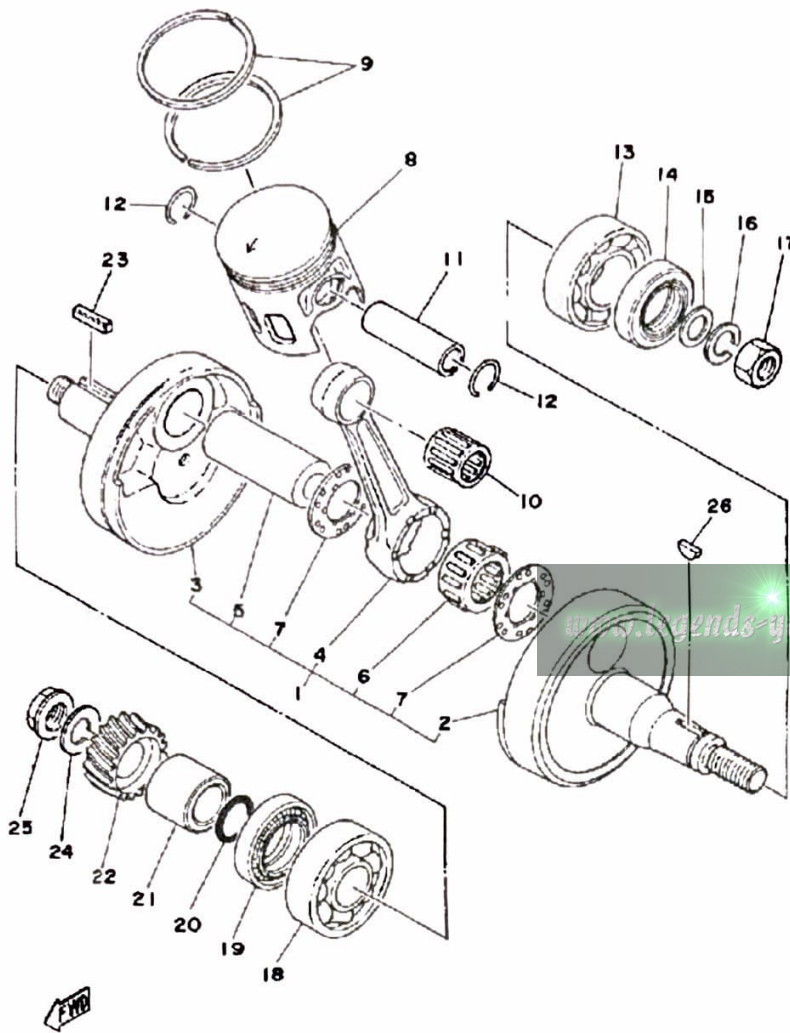

Ref. No.	Part Number	Description	Qty	Remarks
18	93306-20421-00	BEARING	1	
19	93103-28011-00	OIL SEAL	1	
20	93210-180A6-00	O-RING	1	
21	90387-20488-00	COLLAR	1	
22	2A6-16111-00-00	GEAR, PRI DRIVE	1	
23	90282-05005-00	KEY, STRAIGHT	1	
24	90204-12007-00	WASHER, SPRING	1	
25	90179-12244-00	NUT, SPEC"L SHAPE	1	
26	90280-03017-00	KEY, WOODRUFF	1	

OIL PUMP

Ref. No.	Part Number	Description	Qty	Remarks
1	3MT-13116-00-00	GASKET, PUMP CASE (8Y0-13116-00)	1	
2	90201-08624-00	WASHER, PLATE	1	
3	(558-13175-00-00)	SHAFT, WORM	1	
4	93603-22028-00	PIN, DOWEL	1	
5	1E7-13176-00-00	METAL, WRM SHAF OTR	1	
6	93101-10002-00	OIL SEAL	1	
7	90201-105J4-00	WASHER, PLATE (90201-106H1)	1	
8	2A6-13178-00-00	GEAR, PUMP DRIVE	1	
9	99001-08600-00	CIRCLIP	1	
10	98580-05016-00	SCREW, PAN HEAD	2	
11	2A6-13101-00-00	OIL PUMP ASSEMBLY	1	
12	137-13137-00-03	. SHIM (0.3T)	1	UR
	137-13137-00-05	. SHIM (0.5T)	1	UR
	137-13137-00-10	. SHIM (1.0T)	1	UR
13	137-13138-01-00	. PLATE, ADJUSTING	1	
14	92990-05100-00	. WASHER, SPRING	1	
15	95380-05600-00	. NUT	1	
16	90430-04004-00	. GASKET	1	
17	98901-04008-00	. SCREW, BIND	1	
18	93505-32002-00	. BALL	1	
19	90501-02018-00	. SPRING, COMPRESSION	1	
20	402-13552-00-00	. NOZZLE	1	
21	363-13133-01-00	CLIP	1	
22	90467-08003-00	CLIP	2	
23	90445-07219-00	HOSE	1	
24	90468-02025-00	CLIP	1	
25	2A6-13115-01-00	CONNECTOR, SCTN PPE	1	

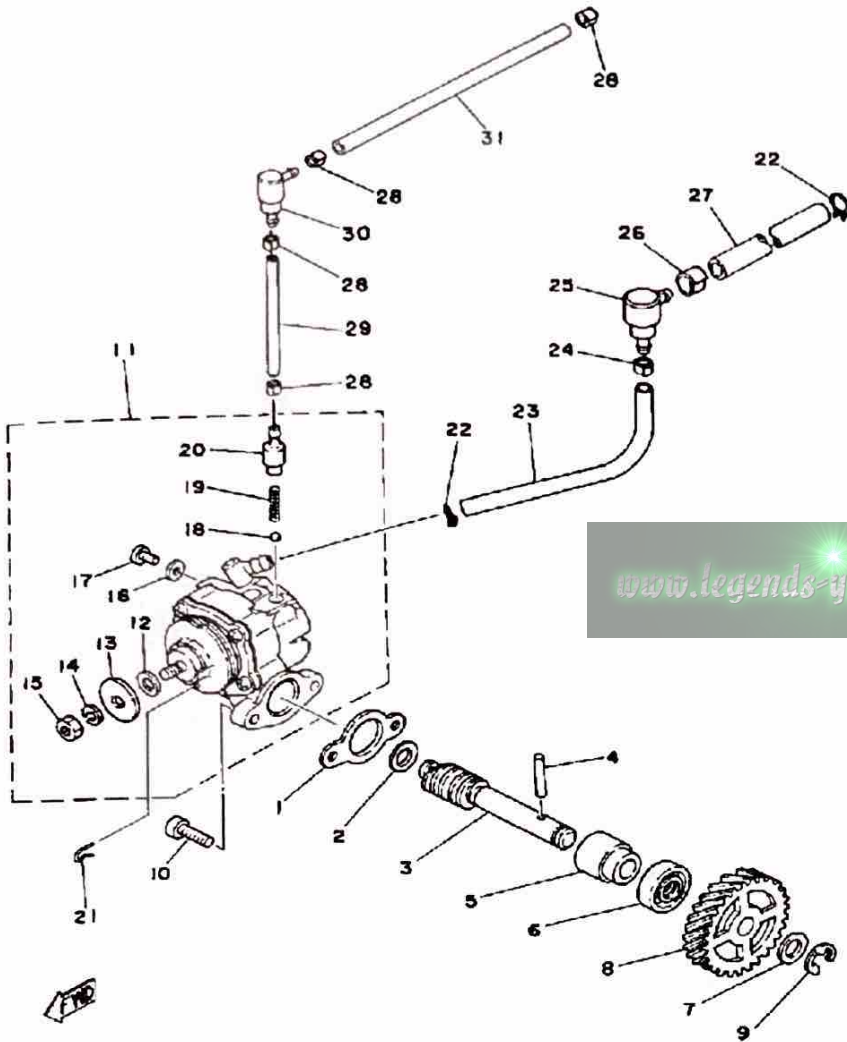

CONTINUED ON NEXT FRAME ►

OIL PUMP

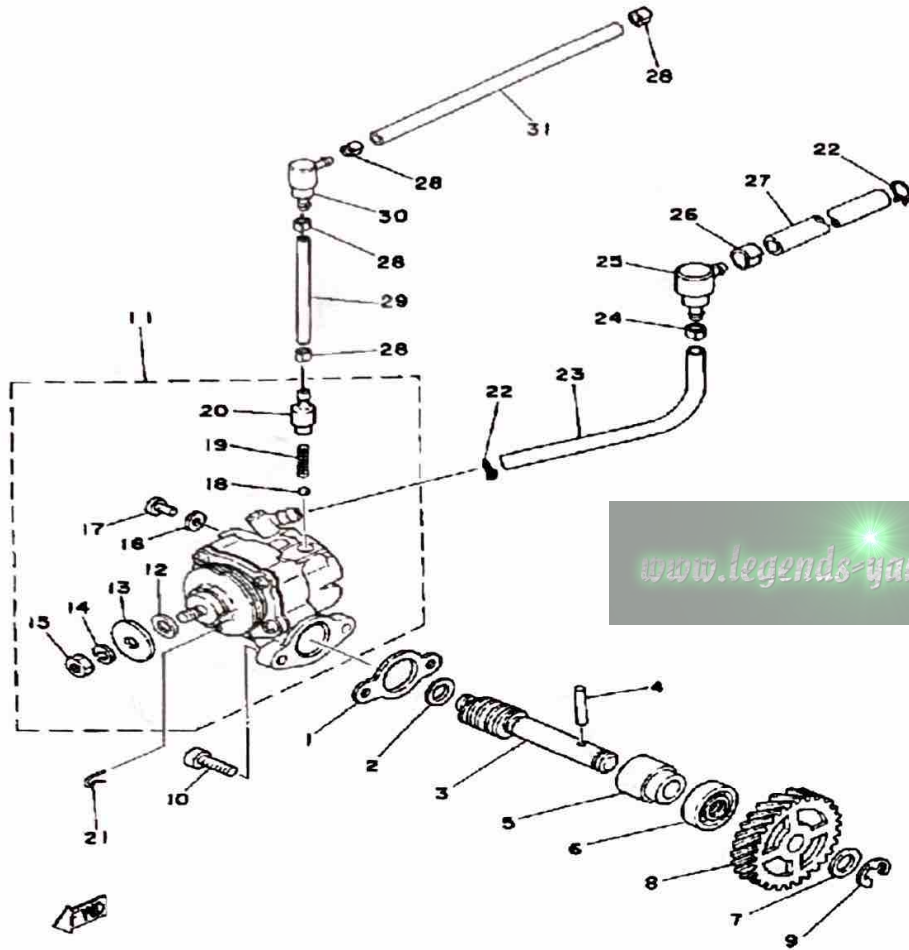

Ref. No.	Part Number	Description	Qty	Remarks
26	90468-02078-00	CLIP	1	
27	90445-09100-00	HOSE	1	
28	90468-02033-00	CLIP	4	
29	90445-05019-00	HOSE	1	
30	2A6-13164-01-00	CONCT, DELIVERY PPE	1	
31	90445-05024-00	HOSE (835-13171-00)	1	

AIR FILTER

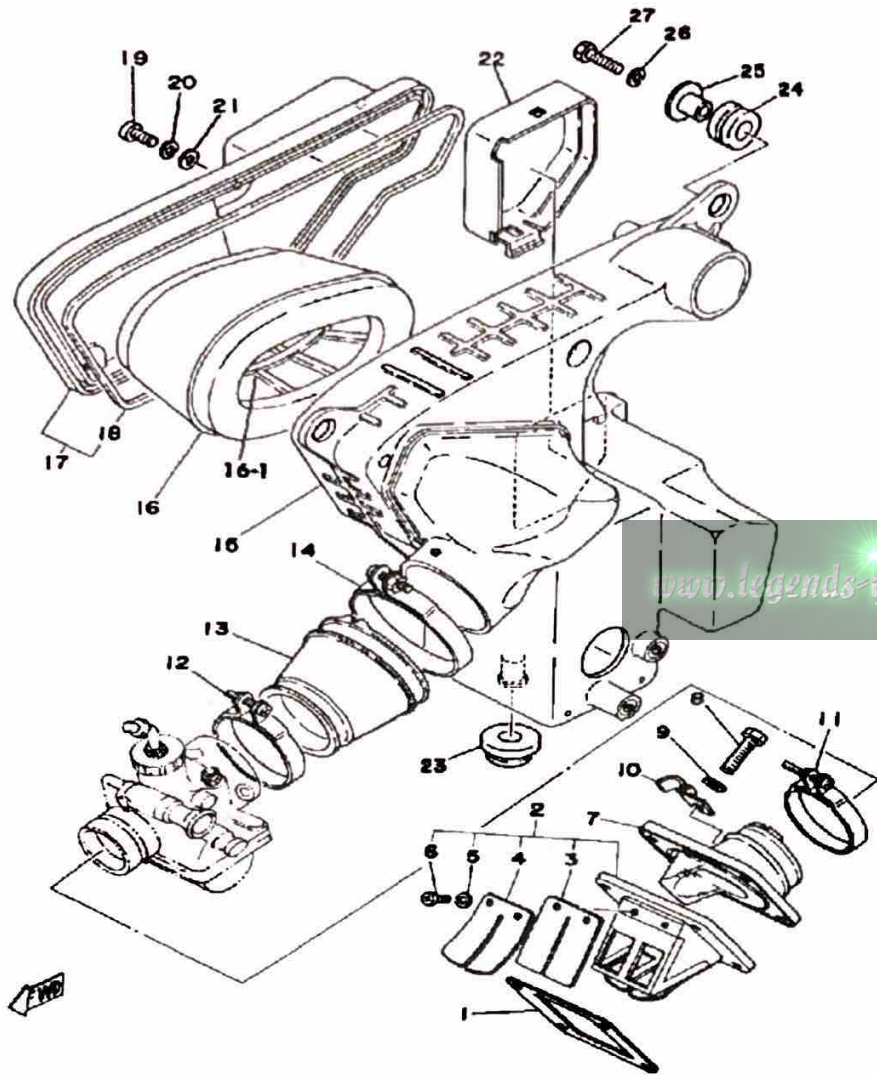

Ref. No.	Part Number	Description	Qty	Remarks
1	87A-13621-00-00	GASKET, VALVE SEAT	1	
2	558-13610-00-00	REED VALVE ASSEMBLY	1	
3	345-13613-70-00	. REED, VALVE	2	
4	345-13616-70-00	. STOPPER, REED VALVE	2	
5	92990-03100-00	. WASHER, SPRING (92901-03100)	4	
6	98580-03008-00	. SCREW, PAN HEAD	4	
7	401-13565-01-00	JOINT, CARBURETOR	2	
8	97011-06025-00	BOLT (97001-06025)	4	
9	92901-06600-00	WASHER	4	
10	90462-05005-00	CLAMP	1	
11	90460-43053-00	CLAMP, HOSE	1	
12	90460-49058-00	CLAMP, HOSE	1	
13	2A7-14453-00-00	JOINT, AIR CLNR 1	1	
14	90460-64065-00	CLAMP, HOSE	1	
15	2A6-14411-01-00	CASE, AIR CLEANER 1	1	
16	2A6-14451-00-00	ELEMENT, AIR CLNR	1	
17	2A6-14412-00-00	CAP, CLEANER CASE 1	1	
18	4L0-14457-01-00	. SEAL	1	
19	98580-05012-00	SCREW, PAN HEAD	5	
20	92990-05100-00	WASHER, SPRING	5	
21	92901-05600-00	WASHER, PLATE	5	
22	2A6-14417-00-00	COVER 1	1	
23	90480-18171-00	GROMMET	1	
24	90480-14023-00	GROMMET	2	
25	90387-07391-00	COLLAR	2	
26	92995-06100-00	WASHER, SPRING	2	
27	10W-14104-00-00	AIR SCREW SET	2	
16-1	2A6-14458-00-00	UNAVAILABLE IN PRICE BOOK	1	

CARBURETOR

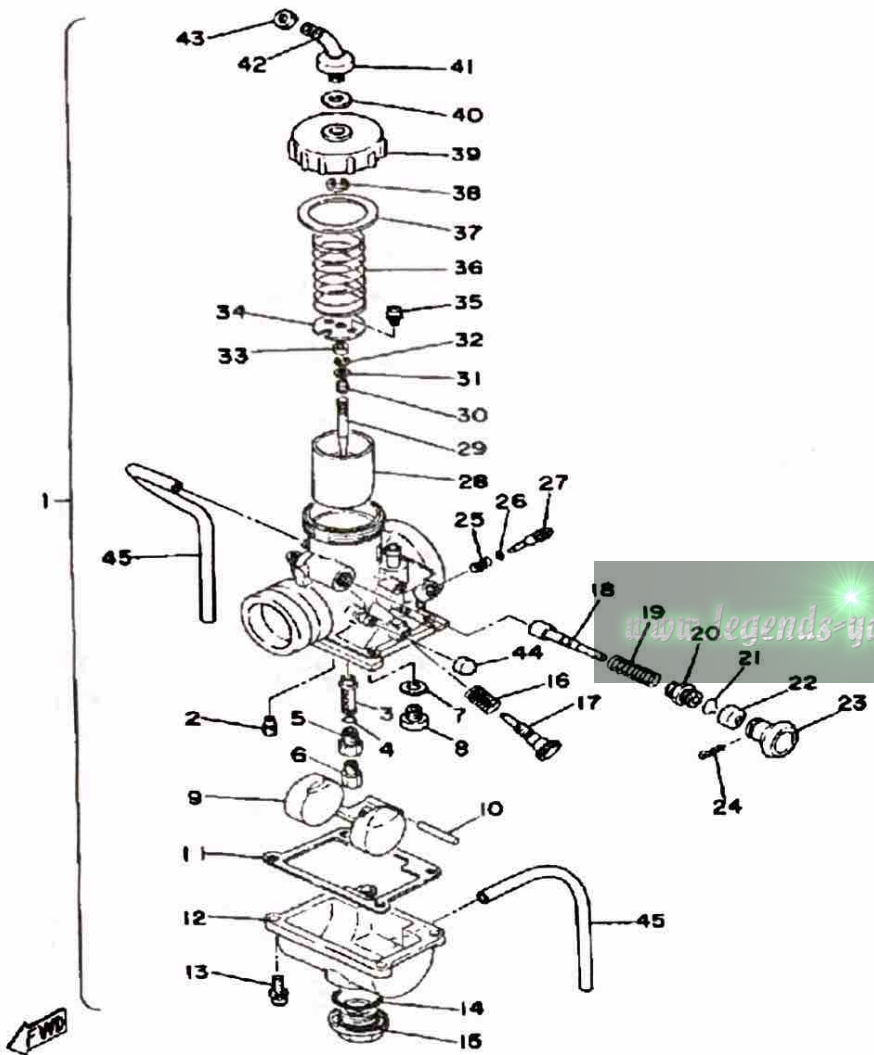

Ref. No.	Part Number	Description	Qty	Remarks
1	2N5-14101-00-00	CARBURETOR ASSEMBLY 1	1	
2	260-14142-20-A0	. JET, PILOT #20.	1	
3	2F5-14141-24-00	. NOZZLE, MAIN (N-4)	1	
4	214-14147-00-00	. O-RING	1	
5	2N4-14145-00-00	. HOLDER	1	
6	137-14143-28-A0	. JET, MAIN (#140)	1	
7	214-14195-00-00	. WASHER, NEEDLE VALVE	1	
8	23L-14107-25-00	. NEEDLE VALVE SET	1	
9	314-14185-00-00	. FLOAT	1	
10	127-14186-00-00	. PIN, FLOAT	1	
11	304-14184-00-00	. GASKET, FLOAT CHAMBER	1	
12	539-14181-04-00	. BODY, FLOAT CHMBR 1	1	
13	(97602-04116-00)	SCREW, PN/HD.W/WSHR	4	
14	558-14147-00-00	. O-RING	1	
15	500-14115-00-00	. PLUG, SCREW	1	
16	493-14133-00-00	. SPRING, THRTL STOP	1	
17	493-14122-00-00	. SCREW, THROTTLE (443-14122-00)	1	
18	304-14171-00-00	. PLUNGER, STARTER	1	
19	156-14135-00-00	. SPRING, PLUNGER	1	
20	152-14174-00-00	. CAP, PLUNGER	1	
21	353-14138-00-00	. CLIP, PLUNGER	1	
22	132-14173-00-00	. COVER, PLUNGER CAP	1	
23	304-14261-00-00	. HOLDER	1	
24	91490-16020-00	. PIN, COTTER	1	
25	174-14134-00-00	. SPRING, AIR ADJUSTING	1	
26	354-14147-00-00	. O-RING	1	
27	22K-14104-00-00	. AIR SCREW SET	1	
28	(2N4-14112-20-00)	VALVE, THROTTLE 1	1	

CONTINUED ON NEXT FRAME ➤

CARBURETOR

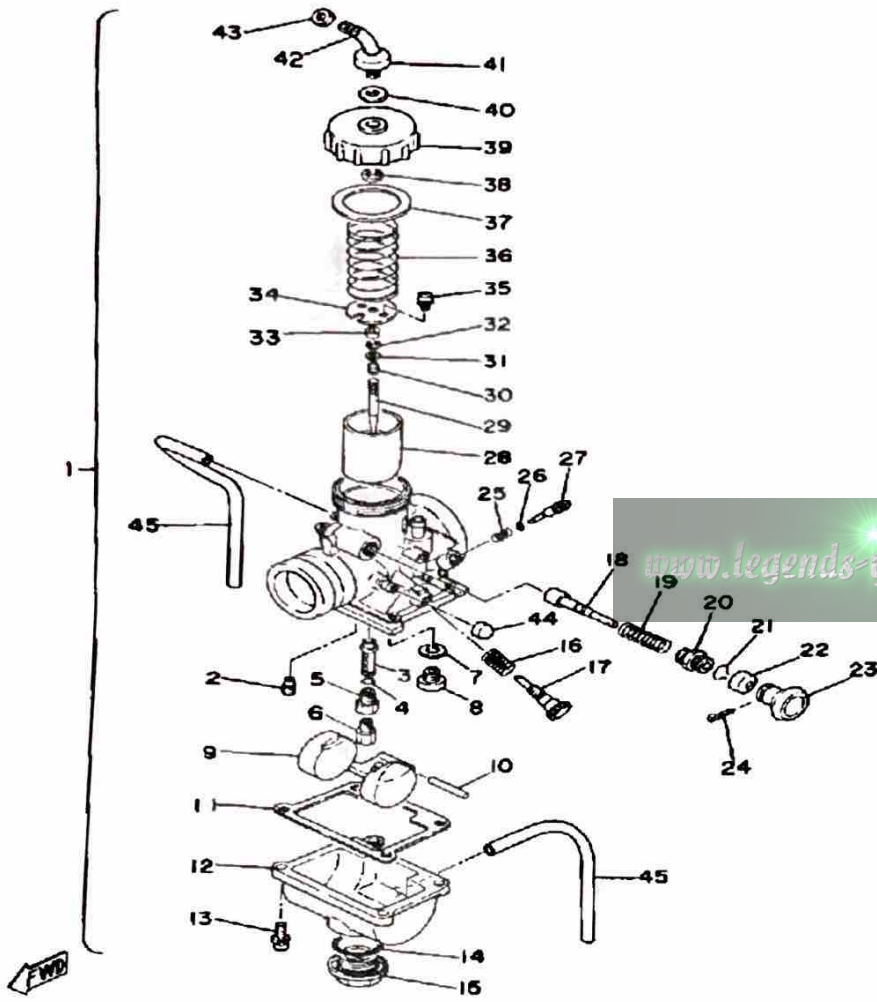

Ref. No.	Part Number	Description	Qty	Remarks
29	(316-14116-11-00)	NEEDLE	1	
30	2H0-14131-00-00	. SPRING, THRTL VALVE	1	
31	2H0-14235-00-00	. WASHER, NEEDLE	1	
32	363-14137-00-00	. CLIP	1	
33	2H0-14194-00-00	. RING	1	
34	(2N4-14936-00-00)	SEAT, SPRING	1	
35	98580-03008-00	. SCREW, PAN HEAD	1	
36	2N4-14131-00-00	. SPRING, THRTL VALVE	1	
37	2A6-14126-00-00	. GASKET	1	
38	164-14137-00-00	CLIP	1	
39	2A6-14158-00-00	. TOP, MIXING CHAMBER	1	
40	509-14198-00-00	. GASKET	1	
41	1M1-14169-00-00	. CAP	1	
42	10X-14106-00-00	. CABLE ADJUST SCREW SET	1	
43	127-14161-00-00	. NUT, CABLE ADJUSTING	1	
44	895-14169-00-00	. CAP	1	
45	23F-14197-00-00	. PIPE, AIRVENT	2	

EXHAUST

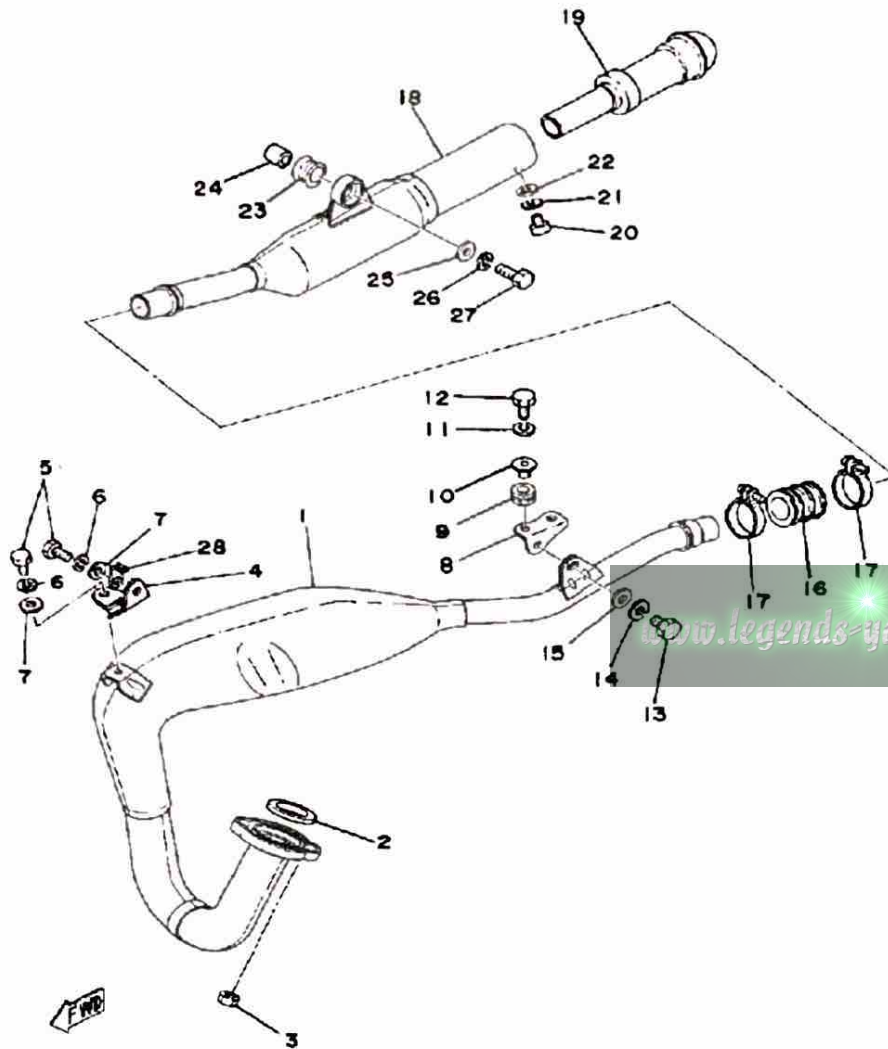

Ref. No.	Part Number	Description	Qty	Remarks
1	3J0-14610-00-00	EXHAUST PIPE ASSEMBLY L (2A6-14610-00)	1	
2	152-14613-00-00	GASKET, EXST PIPE	1	
3	95380-06600-00	NUT	2	
4	2A6-14772-00-00	STAY, MUFFLER 2	1	
5	97313-08018-00	BOLT, HEXAGON (97301-08016)	2	
6	92990-08100-00	WASHER	2	
7	92901-08600-00	WASHER	2	
8	5V7-14771-00-00	STAY, MUFFLER 1	1	
9	90480-14023-00	GROMMET	2	
10	90387-06388-00	COLLAR	2	
11	92995-06100-00	WASHER, SPRING	2	
12	97011-06025-00	BOLT (97001-06025)	2	
13	97313-08018-00	BOLT, HEXAGON (97301-08016)	1	
14	92990-08100-00	WASHER	1	
15	92901-08600-00	WASHER	1	
16	1W2-14714-00-00	GASKET, MUFFLER	1	
17	90460-37026-00	CLAMP, HOSE	2	
18	2A6-14753-00-00	SILENCER, EXHAUST	1	
19	1M1-14752-01-00	PIPE, OUTLET	1	
20	98580-06012-00	SCREW, PAN HEAD	1	
21	92995-06100-00	WASHER, SPRING	1	
22	92901-06600-00	WASHER	1	
23	565-14747-00-00	DAMPER, MUFFLER	1	
24	90387-08258-00	COLLAR	1	
25	90201-08753-00	WASHER, PLATE	1	
26	92990-08100-00	WASHER	1	
27	97313-08030-00	BOLT, HEXAGON	1	
28	2A6-83596-00-00	CLAMP	1	

CRANKCASE COVER

Ref. No.	Part Number	Description	Qty	Remarks
1	2A7-15411-01-00	COVER, CRANKCASE L	1	
2	2A6-15455-01-00	GASKET 1	1	
3	98511-06025-00	SCREW PAN HEAD (92501-06025)	6	
4	2A6-15484-01-00	CLAMP 2	1	
5	2A6-15431-00-00	COVER, CRANKCASE 3	1	
6	18G-15451-01-00	GASKET, CRCS. COVER	1	
7	99530-10014-00	PIN, DOWEL	2	
8	98580-06030-00	SCREW PAN HEAD	3	
9	98580-06040-00	SCREW, pan head (92501-06040-00)	6	
10	2A6-15416-00-00	COVER, OIL PUMP	1	
11	2A6-15456-00-00	GASKET, O/PMP CVR 1	1	
12	98511-06025-00	SCREW PAN HEAD (92501-06025)	4	
13	401-15362-00-00	PLUG, OIL LEVEL	1	
14	(2A7-00000-20-00)	GSKTKT DT175E/F		
	93210-19123-00	O-RING	1	

SEE GRID G-1 FOR COMPONENTS

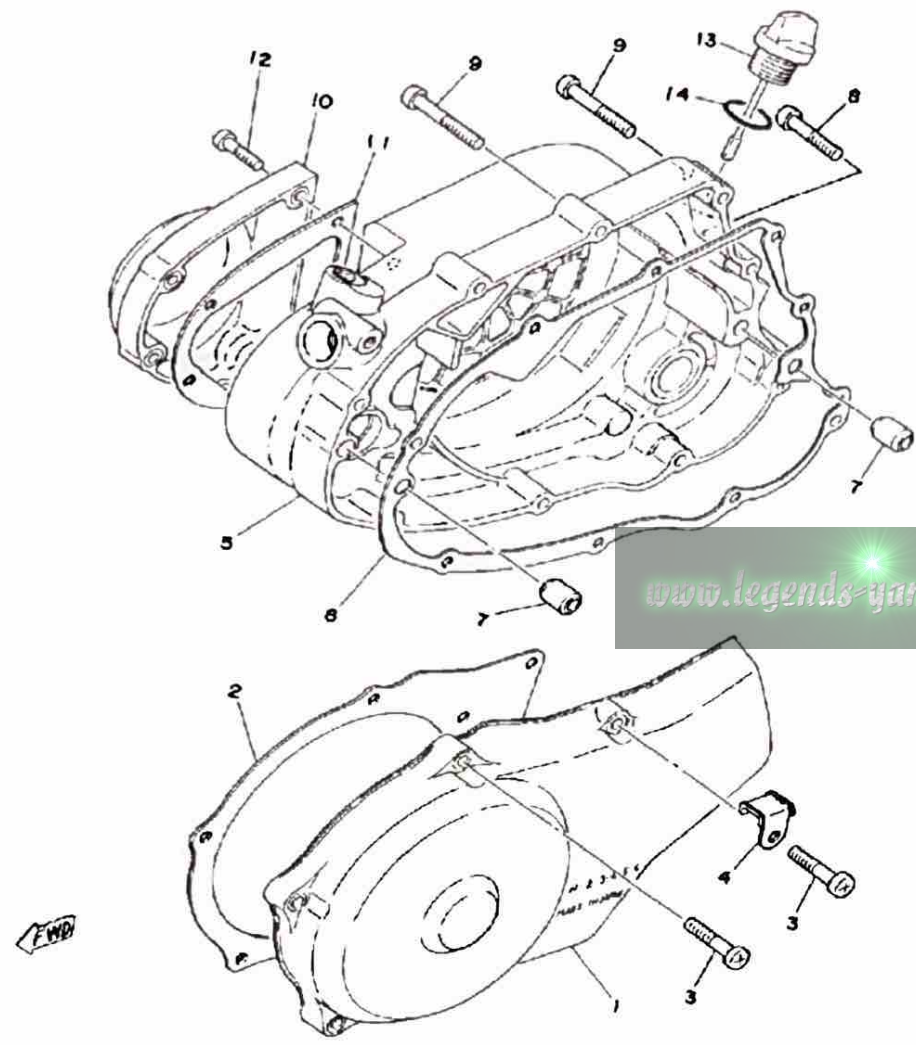

C - D - I - MAGNETO

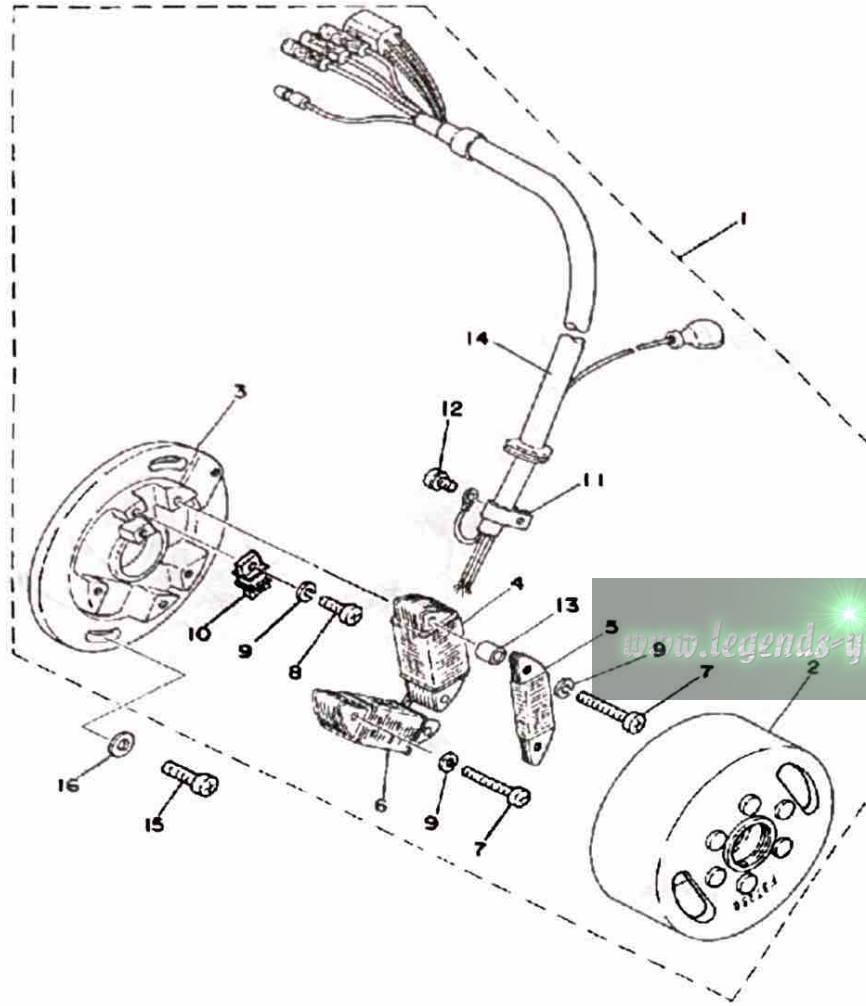

Ref. No.	Part Number	Description	Qty	Remarks
1	(2N5-85500-20-00)	CDI MAGNETO ASSEMBLY ...	1	
2	(2A7-85550-20-00)	ROTOR ASSEMBLY	1	
3	1W2-85509-20-00	. BASE, MAGNETO	1	
4	2A7-85511-20-00	. COIL SOURCE 1	1	
5	2A7-85512-20-00	. COIL SOURCE 2	1	
6	2A7-85513-20-00	. COIL, LIGHTING 1	1	
7	98501-04035-00	. SCREW, PAN HEAD	4	
8	98503-04014-00	. SCREW, PAN HEAD	2	
9	92901-04100-00	. WASHER, SPRING	6	
10	2A7-85580-20-00	. COIL, PULSER	1	
11	445-81328-20-00	. CLAMP	1	
12	97601-04106-00	. SCREW, PN/HD.W/WSHR ...	1	
13	1W2-85516-20-00	. SPACER	2	
14	(2A7-85515-20-00)	LEAD WIRE ASSEMBLY	1	
15	98503-06014-00	SCREW, PAN HEAD (92502-06016)	2	
16	92901-06600-00	WASHER	2	



STARTER

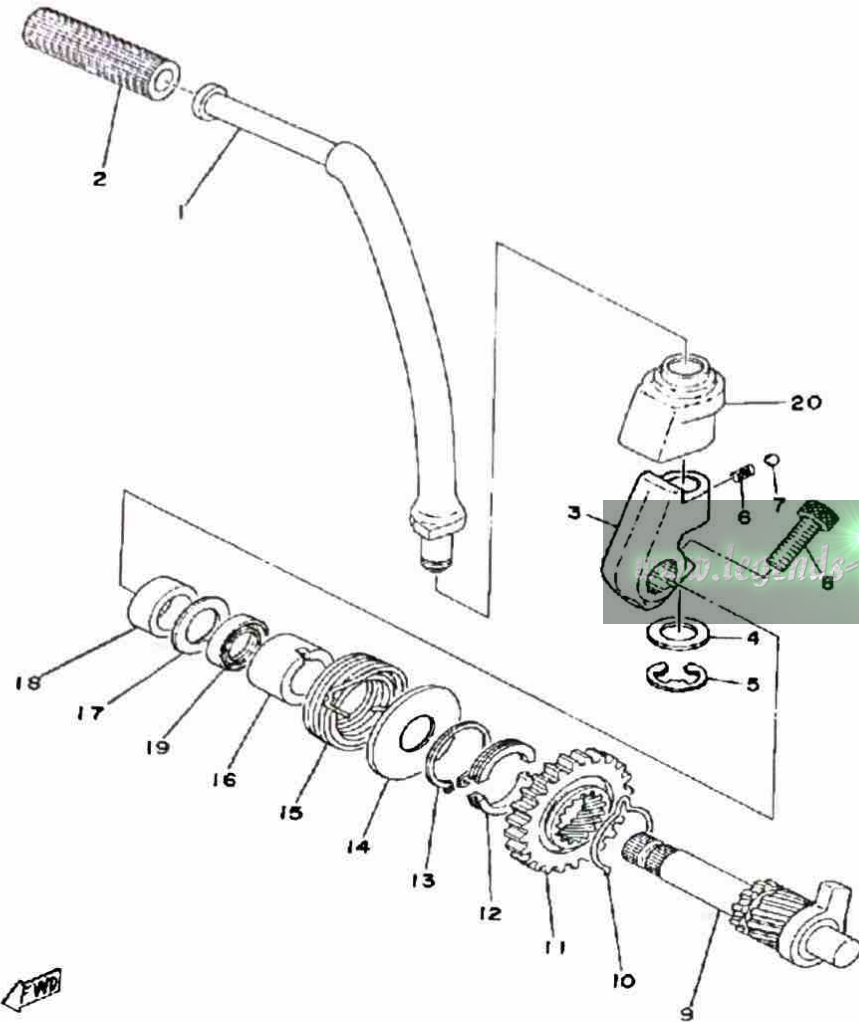

Ref. No.	Part Number	Description	Qty	Remarks
1	2A6-15620-01-00	KICK CRANK ASSEMBLY	1	
2	156-15618-01-00	COVER, KICK LEVER	1	
	1W1-15621-01-00	BOSS, KICK CRANK	1	
4	90201-12541-00	WASHER, PLATE	1	
5	93430-08007-00	CIRCLIP	1	
6	90501-10459-00	SPRING, COMPRESSION	1	
7	93503-16010-00	BALL	1	
8	91316-08025-00	BOLT, SOCKET HEAD	1	
9	2A6-15660-01-00	KICK AXLE ASSEMBLY	1	
10	90468-26048-00	CLIP	1	
11	1W1-15641-00-00	GEAR, KICK (27T)	1	
12	248-15654-00-00	HOLDER, KICK GEAR	2	
13	99009-30400-00	CIRCLIP	1	
14	401-15676-00-00	COVER, SPRING	1	
15	90508-16346-00	UNAVAILABLE IN PRICE BOOK	1	
16	1W1-15666-00-00	SPACER	1	
17	90201-17327-00	WASHER, PLATE	1	
18	90560-17032-00	SPACER	1	
19	93101-17062-00	OIL SEAL	1	
20	1W1-15618-01-00	COVER, KICK LEVER	1	

FWD

TACHOMETER

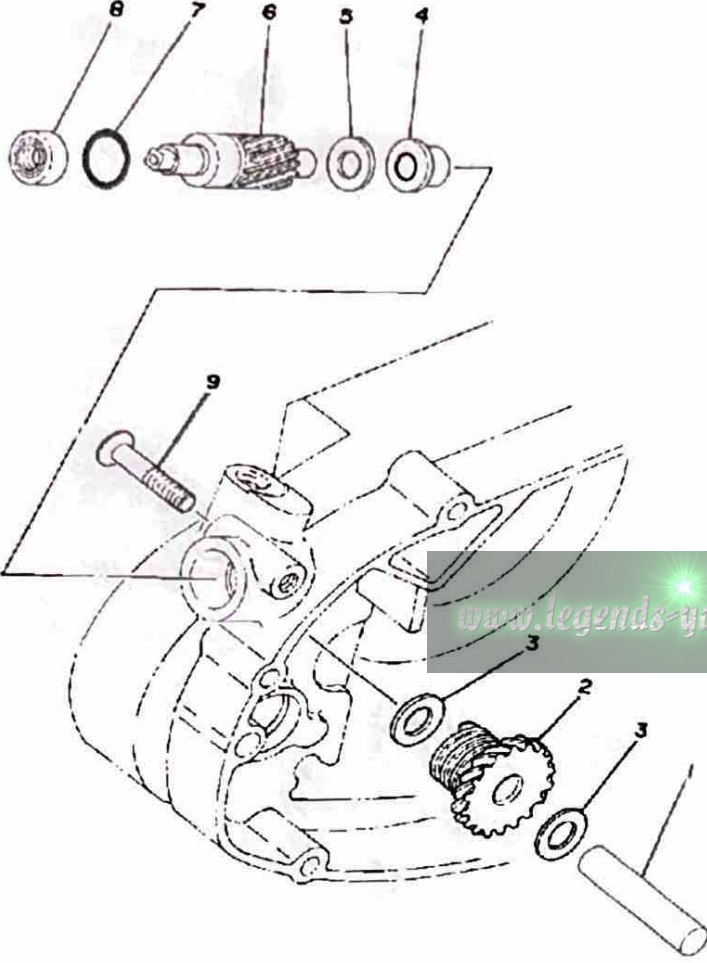

Ref. No.	Part Number	Description	Qty	Remarks
1	(248-17861-00-00)	AXLE, DRIVE GEAR	1	
2	2A6-17831-00-00	GEAR, DRIVE	1	
3	90201-10123-00	WASHER, PLATE (10.5-18-1.6) (256-21715-00) 0 2	2	
4	90381-08002-00	BUSHING (214-17843-00)	1	
5	90201-12M34-00	WASHER, PLATE	1	
6	(2A6-17841-00-00)	GEAR, DRIVEN	1	
7	93210-14104-00	O-RING	1	
8	93102-08307-00	OIL SEAL	1	
9	98780-06030-00	SCREW, FLAT HEAD	1	

FWD

CLUTCH

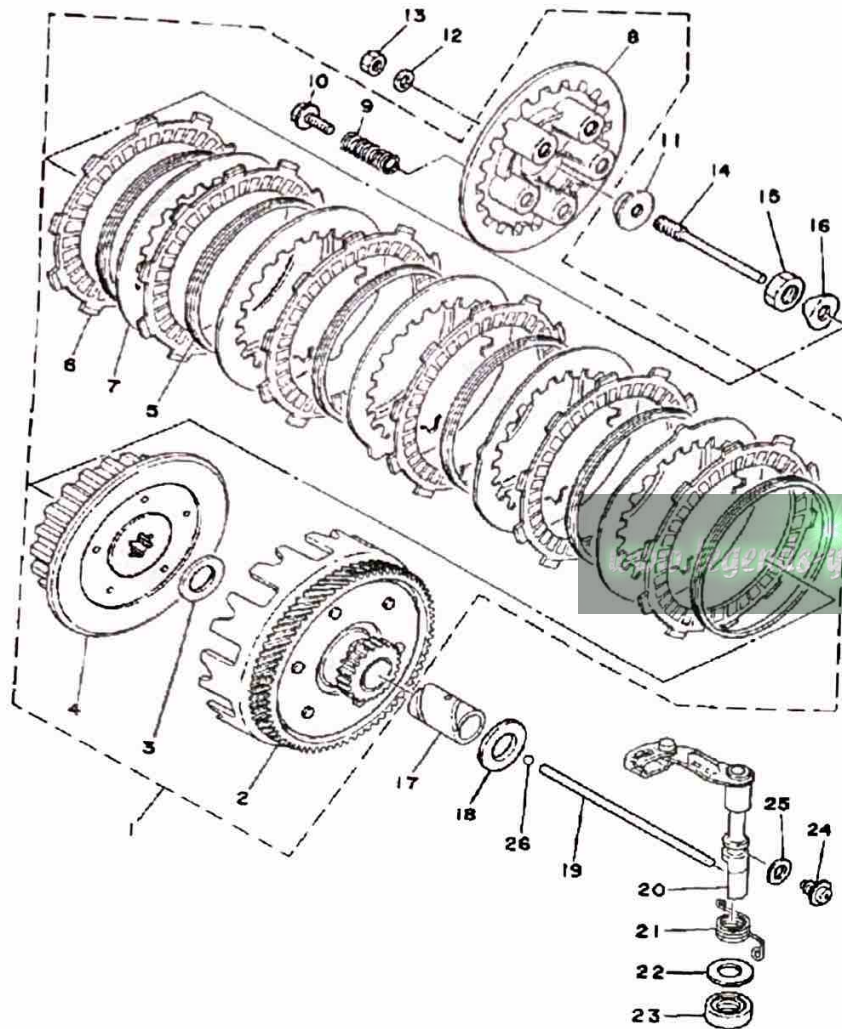

Ref. No.	Part Number	Description	Qty	Remarks
1	3J1-16300-00-00	CLUTCH ASSEMBLY CLUTCH ASSEMBLY (2A7-16301-00) . . .	1	
2	2A7-16150-00-00	. PRI DRVN GEAR COMP. (71T)	1	
3	90201-17543-00	. WASHER, PLATE	1	
4	1G8-16371-00-00	. BOSS, CLUTCH	1	
5	307-16367-00-00	. RING, CUSHION	6	
6	559-16321-01-00	. PLATE, FRICTION	6	
7	2A6-16324-00-00	. PLATE, CLUTCH 1	5	
8	1W1-16351-00-00	. PLATE, PRESSURE 1	1	
9	90501-20474-00	. SPRING, COMPRESSION	5	
10	90159-05011-00	. SCREW, WITH WASHER	5	
11	30X-16358-00-00	PLATE, PUSH	1	
12	92990-06200-00	WASHER	1	
13	95380-06600-00	NUT	1	
14	1W1-16356-02-00	ROD, PUSH 1	1	
15	90170-14171-00	NUT	1	
16	90215-14204-00	WASHER, LOCK	1	
17	90560-17147-00	SPACER	1	
18	90201-174E1-00	WASHER, PLATE	1	
19	1W1-16357-00-00	ROD, PUSH 2	1	
20	(1W1-16380-00-00)	PUSH LEVER ASSEMBLY	1	
21	90508-20345-00	SPRING, TORSION	1	
22	90201-14217-00	WASHER, PLATE	1	
23	93104-14059-00	OIL SEAL, SO-TYPE	1	
24	90149-08108-00	SCREW, SPEC'L SHAPE	1	
25	90430-08069-00	GASKET	1	
26	93503-16010-00	BALL	1	

TRANSMISSION

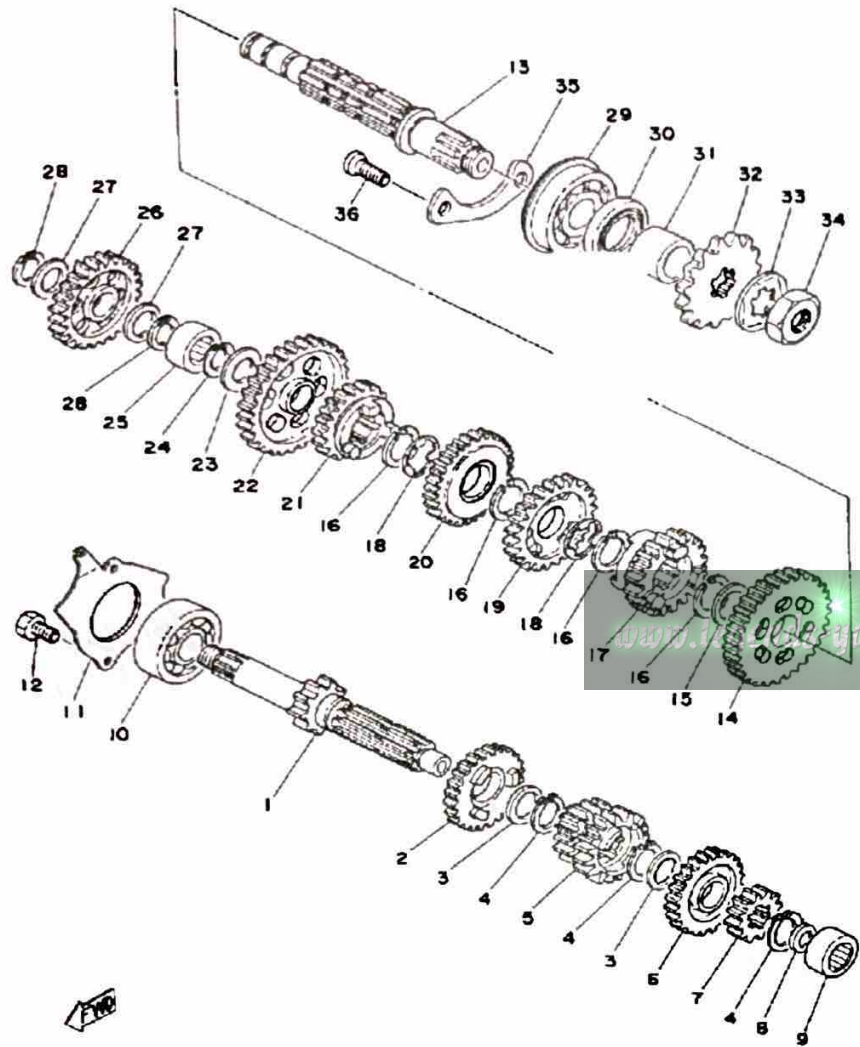

Ref. No.	Part Number	Description	Qty	Remarks
1	2A6-17411-00-00	AXLE, MAIN	1	
2	1W2-17151-00-00	GEAR, 5TH PINION	1	
3	90201-20266-00	WASHER, PLATE (1.0T)	2	
4	93410-20038-00	CIRCLIP	3	
5	2A6-17131-00-00	GEAR, 3RD PINION	1	
6	1W2-17161-00-00	GEAR, 6TH PINION	1	
7	2A6-17121-00-00	GEAR, 2ND PINION	1	
8	90201-15701-00	WASHER, PLATE (1.0T)	1	
9	93311-41530-00	BEARING	1	
10	93306-30309-00	BEARING	1	
11	1W1-17471-01-00	PLATE, COVER	1	
12	97013-06012-00	BOLT	2	
13	2A6-17421-00-00	AXLE, DRIVE	1	
14	2A6-17221-01-00	GEAR, 2ND WHEEL (2A6-17221-00)	1	
15	90201-22555-00	WASHER, PLATE	1	
16	93410-22039-00	CIRCLIP	4	
17	2A6-17261-00-00	GEAR, 6TH WHEEL	1	
18	90209-18135-00	WASHER	2	
19	1W2-17241-00-00	GEAR, 4TH WHEEL	1	
20	2A6-17231-00-00	GEAR, 3RD WHEEL	1	
21	2A6-17251-00-00	GEAR, 5TH WHEEL	1	
22	2A6-17211-01-00	GEAR, 1ST WHEEL (2A6-17211-00)	1	
23	90201-15701-00	WASHER, PLATE (1.0T)	1	
24	92440-15012-00	UNAVAILABLE IN PRICE BOOK (15 O SPECIAL)	1	
25	93311-31567-00	BEARING, CYLINDRICAL	1	
26	525-15651-00-00	GEAR, KICK IDLE (25T)	1	
27	137-17417-00-05	SHIM 1 (0.5T)	2	

CONTINUED ON NEXT FRAME ►

TRANSMISSION

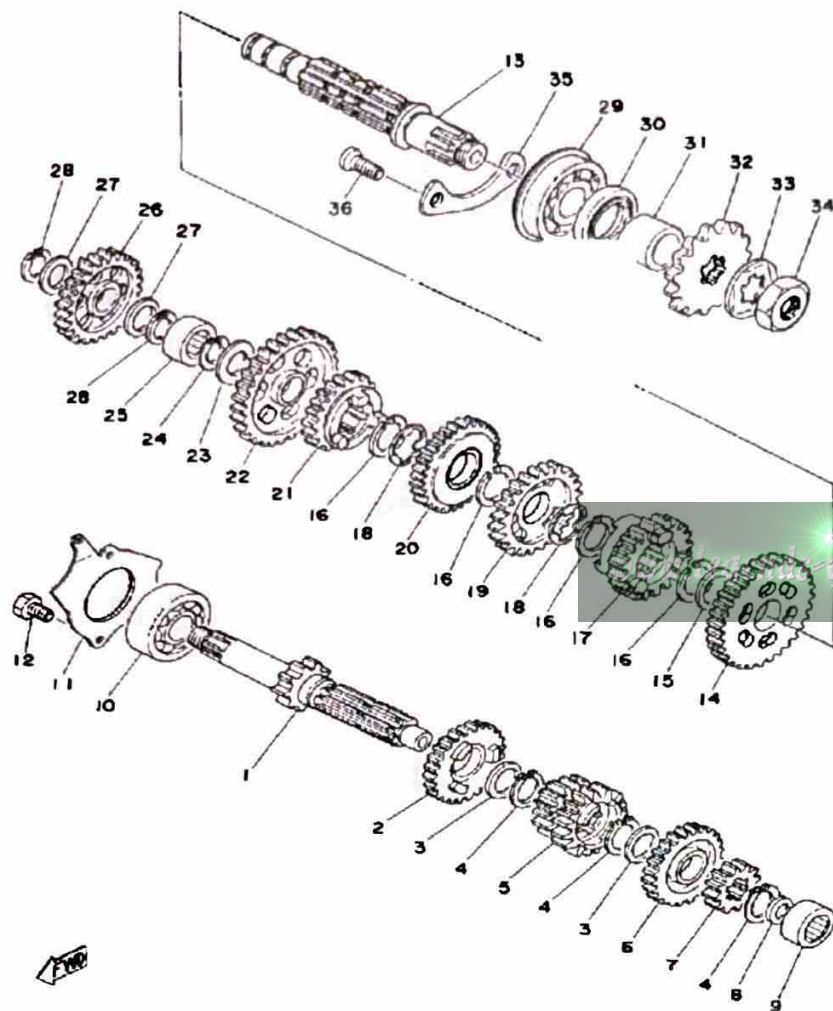

Ref. No.	Part Number	Description	Qty	Remarks
28	93440-15012-00	CIRCLIP	2	
29	93306-30411-00	BEARING (B6304)	1	
30	93102-26042-00	OIL SEAL	1	
31	90387-202A0-00	COLLAR	1	
32	93822-16093-00	SPROCKET, DRIVE	1	
33	90215-16127-00	WASHER, LOCK	1	
34	90179-16226-00	NUT	1	
35	1W1-15381-00-00	PLATE, BRNG COVER	1	
36	98603-06012-00	SCREW, OVAL HEAD (92701-06012)	2	

SHIFT CAM - FORK

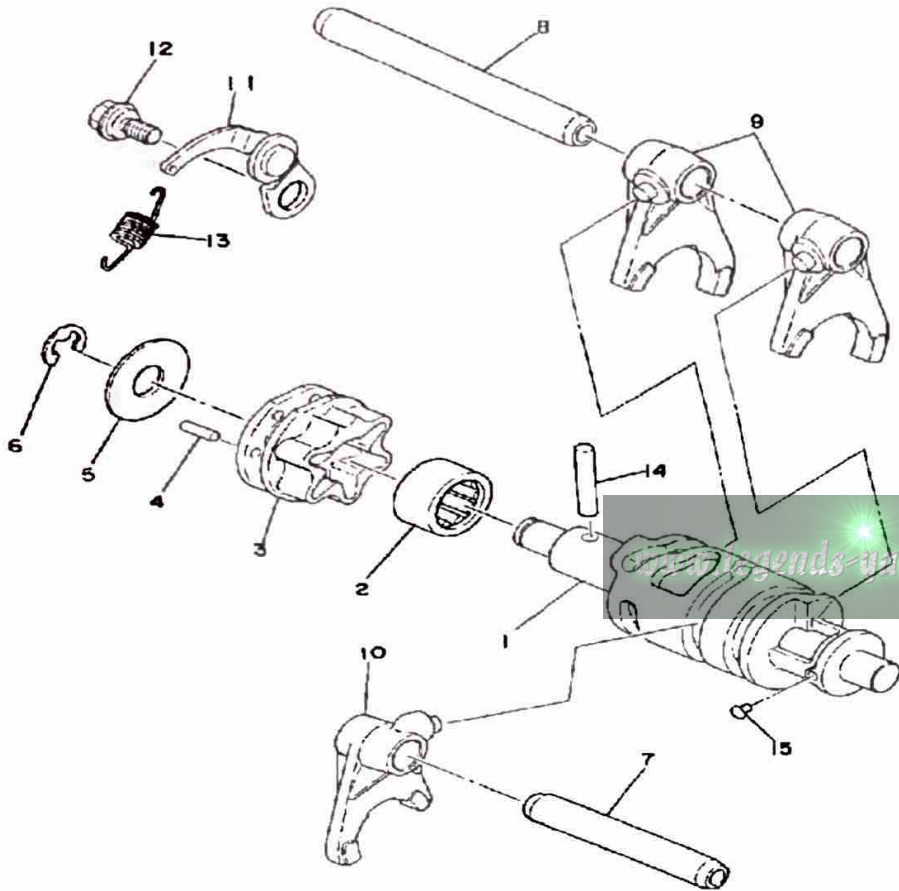

Ref. No.	Part Number	Description	Qty	Remarks
1	1W1-18540-00-00	SHIFT CAM ASSEMBLY	1	
2	93315-21813-00	BEARING	1	
3	1W1-18185-00-00	SEGMENT	1	
4	93604-12037-00	PIN, DOWEL	6	
5	1W1-18561-00-00	PLATE, SIDE 1	1	
6	99001-08600-00	CIRCLIP	1	
7	2A6-18531-00-00	BAR, SHIFT FORK GUIDE 1 ...	1	
8	2A6-18535-00-00	BAR, SHIF FRK GDE 2	1	
9	2A6-18511-00-00	FORK, SHIFT 1	2	
10	2A6-18512-00-00	FORK, SHIFT 2	1	
11	1W1-18140-00-00	STOPPER LEVER ASSEMBLY .	1	
12	50W-21631-00-00	BOLT 1	1	
13	90506-09156-00	SPRING, TENSION	1	
14	93604-30018-00	PIN, DOWEL	1	
15	136-18542-00-00	POINT, NEUTRAL	1	



SHIFT SHAFT

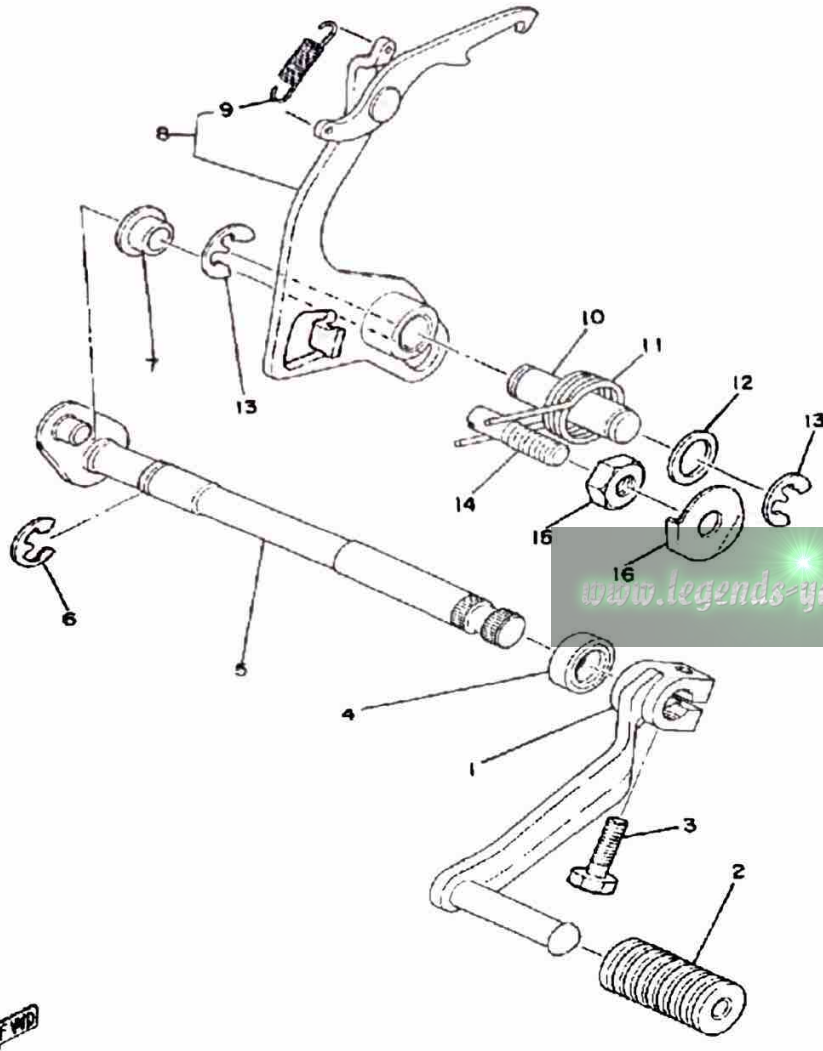

Ref. No.	Part Number	Description	Qty	Remarks
1	2A6-18111-00-00	PEDAL, SHIFT	1	
2	132-18113-01-00	COVER, SHIFT PEDAL	1	
3	97011-06020-00	BOLT	1	
4	93101-12060-00	OIL SEAL	1	
5	1W1-18101-03-00	SHIFT SHAFT ASSEMBLY 1 ..	1	
6	99006-10600-00	CIRCLIP	1	
7	401-18178-00-00	ROLLER, SHIFT LEVER	1	
8	4F2-18120-00-00	SHIFT LEVER ASSEMBLY (2A6-18120-00)	1	
9	90506-08155-00	. SPRING, TENSION	1	
10	1W1-18197-01-00	SHAFT	1	
11	90508-32349-00	SPRING, TORSION	1	
12	90201-12M34-00	WASHER, PLATE	1	
13	99006-10600-00	CIRCLIP	2	
14	90149-08111-00	SCREW, SPEC"L SHAPE	1	
15	90170-08029-00	NUT	1	
16	90215-08014-00	WASHER, LOCK	1	

FWD

FRAME - SIDE COVER

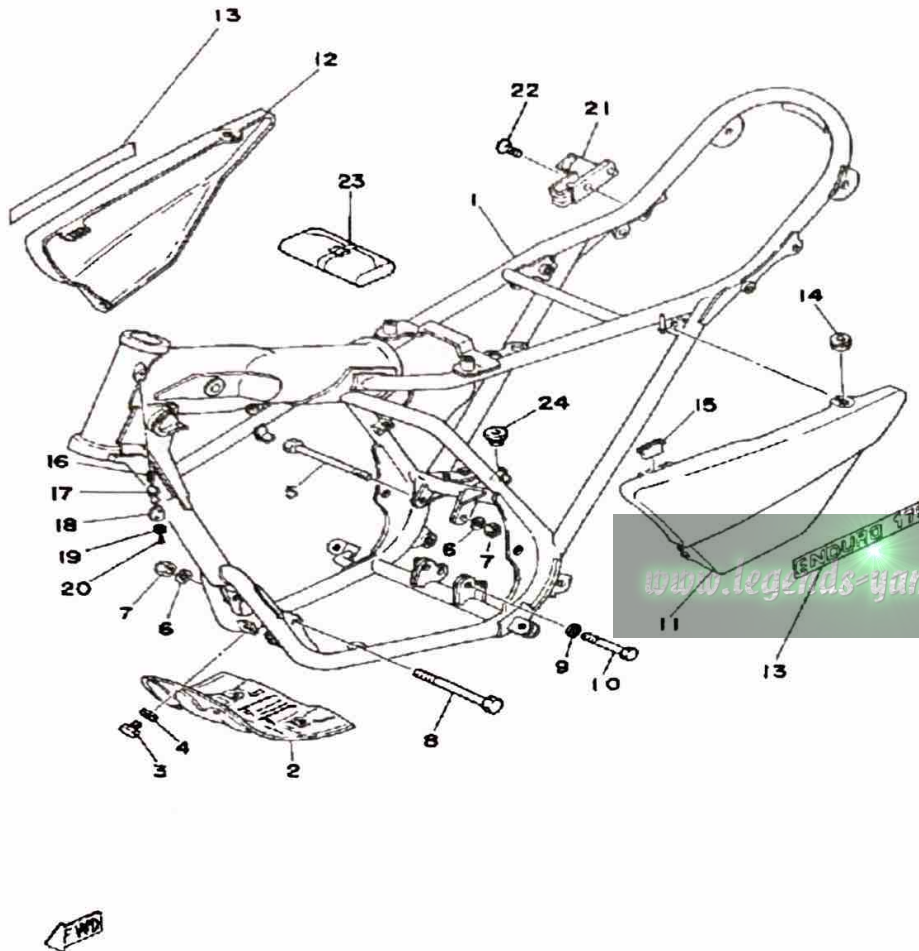

Ref. No.	Part Number	Description	Qty	Remarks
1	(2N4-21110-00-33)	FRAME	1	YAMAHA BK
2	(2A6-21471-00-90)	PROTECTOR, ENGINE	1	YAMAHA BK
3	97013-06012-00	BOLT	4	
4	92901-06600-00	WASHER	4	
5	90105-08120-00	BOLT, WASHER BASED	1	
6	92990-08200-00	WASHER, PLAIN	2	
7	90185-08089-00	NUT, SELF-LOCKING	2	
8	90105-08099-00	BOLT, WASHER BASED	1	
9	92990-10100-00	WASHER, SPRING	1	
10	90105-10037-00	BOLT, WASHER BASED	1	
11	2N4-21711-01-20	COVER, SIDE 1 (2N4-21711-00-20)	1	CRYSTL SLV
	2N4-21711-01-66	COVER, SIDE 1 (2N4-21711-00-66)	1	RED
12	2N4-21721-01-20	COVER, SIDE 2	1	CRYSTL SLV
	2N4-21721-01-66	COVER, SIDE 2 (2N4-21721-00-66)	1	RED
13	3J1-21786-10-00	EMBLEM 6 (2N5-21786-00) ...	2	
14	90480-12053-00	GROMMET	4	
15	2N4-21717-00-00	DAMPER	2	
16	90502-09024-00	SPRING, CONICAL	1	
17	2A6-23408-00-00	STEERING LOCK ASSEMBLY .	1	
18	3DM-23484-00-00	CAP, HANDLE LOCK	1	
19	90206-04003-00	WASHER, WAVE (214-23488-00)	1	
20	90269-04003-00	RIVET	1	
21	55E-21308-00-00	HELMET HANGER ASSEMBLY	1	
22	98603-06018-00	SCREW, OVAL HEAD	1	
23	2A6-W2810-00-00	TOOL KIT	1	
24	90480-18171-00	GROMMET	1	

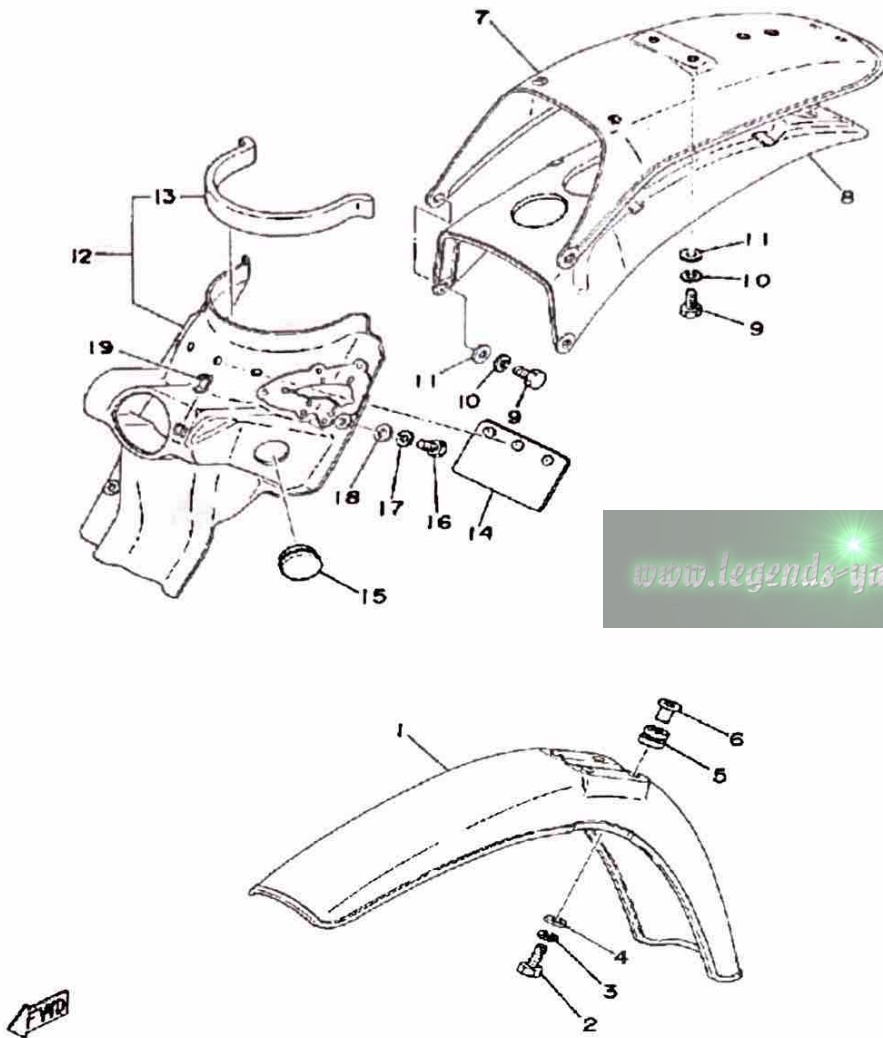

FENDER

Ref. No.	Part Number	Description	Qty	Remarks
1	(2N5-21511-10-20)	FENDER, FRONT	1	CRYSTL SLV
	3V6-21511-10-00	FENDER, FRONT	1	SUNSHINE RED
2	97011-06025-00	BOLT (97001-06025)	4	
3	92995-06100-00	WASHER, SPRING	4	
4	90201-06067-00	WASHER, PLATE	4	
5	90480-14198-00	GROMMET	4	
6	90387-06388-00	COLLAR	4	
7	2A8-21611-A0-00	FENDER, REAR	1	SUNSHINE RED
	2N5-21611-10-20	FENDER, REAR	1	CRYSTL SLV
8	2A6-21617-01-00	BRACKET, FENDER (2A6-21617-00)	1	
9	97313-06016-00	BOLT, HEXAGON	4	
10	92995-06100-00	WASHER, SPRING	4	
11	92901-06600-00	WASHER	4	
12	(99999-01151-00)	GUARD, MUD	1	
	90480-01254-00	. GROMMET	2	
13	2A6-21639-00-00	. DAMPER 2	1	
14	1M1-21621-00-00	FLAP	1	
15	(90480-01230-00)	GROMMET	2	
16	97313-06016-00	BOLT, HEXAGON	3	
17	92995-06100-00	WASHER, SPRING	3	
18	90201-06067-00	WASHER, PLATE	3	
19	2A-62163-70-0-	UNAVAILABLE IN PRICE BOOK	1	

SWING ARM - CHAIN CASE

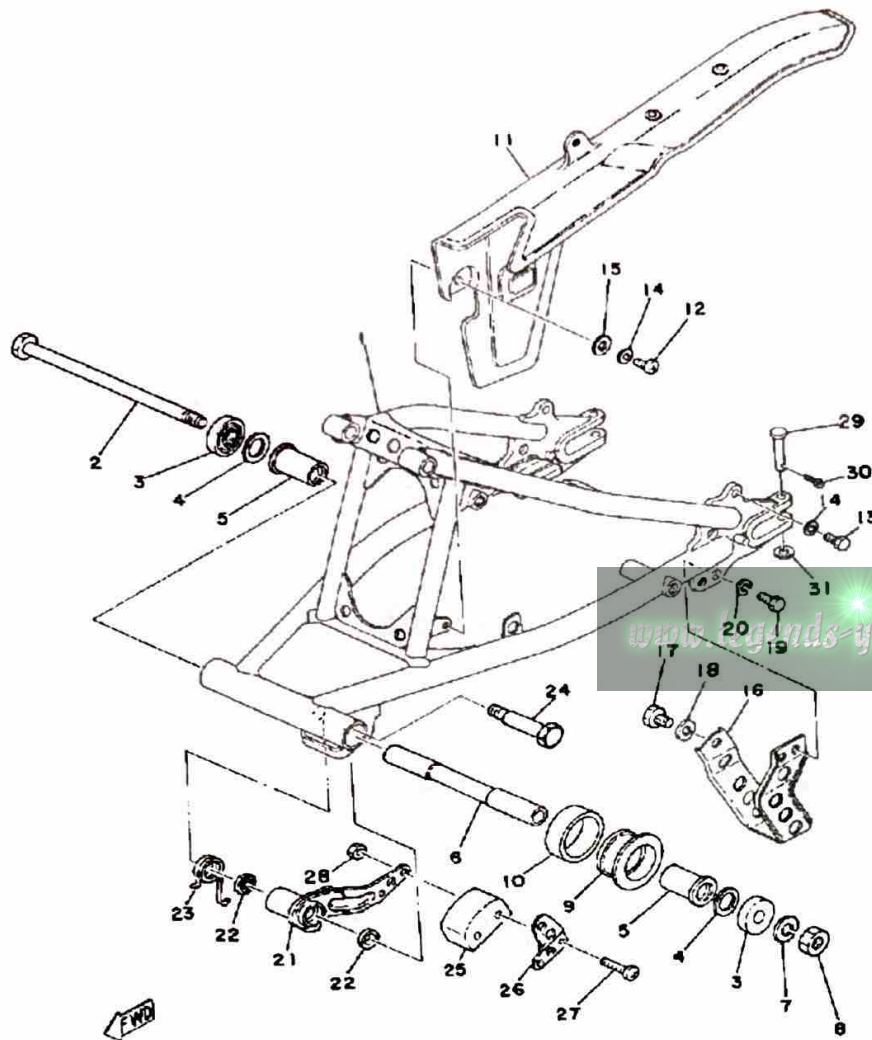

Ref. No.	Part Number	Description	Qty	Remarks
1	(2A6-22110-01-33)	REAR ARM	1	YAMAHA BK
2	2N4-22141-00-00	SHAFT, PIVOT	1	
3	401-22128-01-00	SEAL, GUARD	2	
4	401-22127-00-00	SHIM	1	
5	90386-18028-00	BUSH	2	
6	18G-22124-00-00	BUSH 2	1	
7	92901-12100-00	WASHER, SPRING	1	
8	90185-12046-00	NUT, SELF-LOCKING	1	
9	2A6-22151-00-00	SEAL, GUARD	1	
10	2A6-22152-00-00	SEAL, GUARD	1	
11	2A6-22311-01-00	. CASE, CHAIN	1	
	3J0-22131-00-00	. STAY, CHAIN CASE 1	1	
	3J0-22147-00-00	. PORTECTOR, CHAIN	1	
	90387-05682-00	. COLLAR	2	
	92990-05600-00	. WASHER, PLATE	2	
	97313-05016-00	. BOLT, HEXAGON	2	
	99999-01094-00	CASE, CHAINCASE, CHAIN (2A6-22311-00-98)	1	LOW GLOSS BLACK
12	98580-05016-00	SCREW, PAN HEAD	2	
13	97313-05012-00	BOLT, HEXAGON	1	
14	92990-05100-00	WASHER, SPRING	3	
15	90201-05036-00	WASHER, PLATE	2	
16	2A6-22318-00-00	GUARD, CHAIN	1	
17	97313-08012-00	BOLT	1	
18	92990-08100-00	WASHER	1	
19	97313-06016-00	BOLT, HEXAGON	2	
20	92995-06100-00	WASHER, SPRING	2	
21	2A6-22179-00-00	ARM, TENSIONER	1	
22	93104-14044-00	OIL SEAL	2	

CONTINUED ON NEXT FRAME ►

SWING ARM - CHAIN CASE

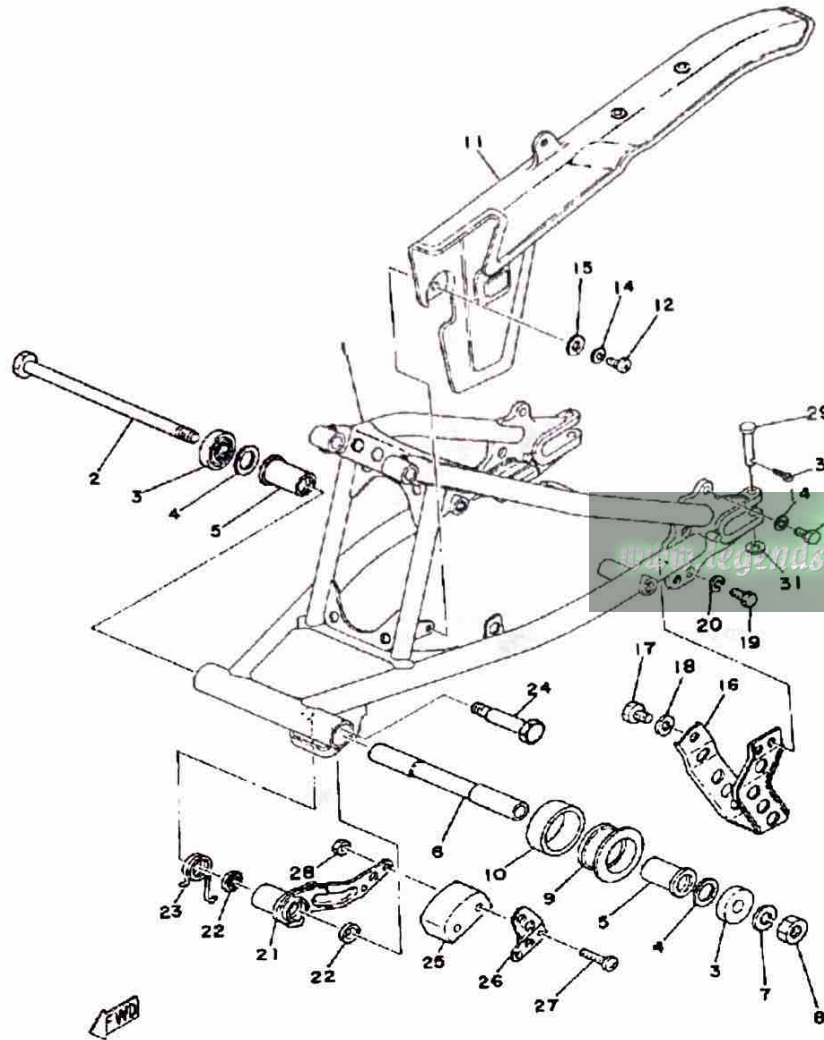

Ref. No.	Part Number	Description	Qty	Remarks
23	90508-35350-00	SPRING, TORSION	1	
24	90109-10483-00	BOLT (90109-10533-00)	1	
25	ACC-11130-00-25	TENSIONER (2N0-22178-00-00)	1	
26	1W1-22187-00-00	GUIDE, CHAIN	1	
27	98501-05035-00	SCREW, PAN HEAD	2	
28	95311-05700-00	NUT	2	
29	91701-06042-00	PIN, CLEVIS	2	
30	91490-20020-00	PIN, COTTER	2	
31	92901-06600-00	WASHER	2	

REAR SHOCK

Ref. No.	Part Number	Description	Qty	Remarks
1	(2N4-22210-01-00)	SHK/ABS ASSEMBLY, REAR .	1	
2	(1M1-22219-01-00)	BRACKET, UPPER	1	
3	1M1-22216-00-00	. BUSH, REAR SHOCK ABSORBER	1	
4	(2N4-22213-00-00)	SEAT, SPRING UPPER	1	
5	91401-30040-00	. PIN, COTTER	1	
6	(90501-90514-00)	SPRING, COMPRESSION	1	
	(90501-95515-00)	SPRING, COMPRESSION	1	AP
7	2N-42249-60-0-	. UNAVAILABLE IN PRICE BOOK	1	
8	(2A6-22493-00-00)	BUMP, STOP	1	
9	90380-12051-00	. BUSH, SOLID	2	
10	(2N4-22401-01-00)	DAMPER SUB-ASSEMBLY.	1	
11	2N-42221-40-0-	. UNAVAILABLE IN PRICE BOOK	1	
12	1W1-22128-00-00	COVER, THRUST 1	2	
13	90109-10550-00	BOLT (90109-10453-00)	1	
14	92990-10200-00	WASHER, PLAIN	1	
15	95303-10900-00	NUT, SLOTTED	1	
16	91490-20025-00	PIN, SPLIT	1	
17	90240-12059-00	PIN, CLEVIS	1	
18	92990-12600-00	WASHER, PLATE	1	
19	91401-30030-00	PIN, COTTER	1	

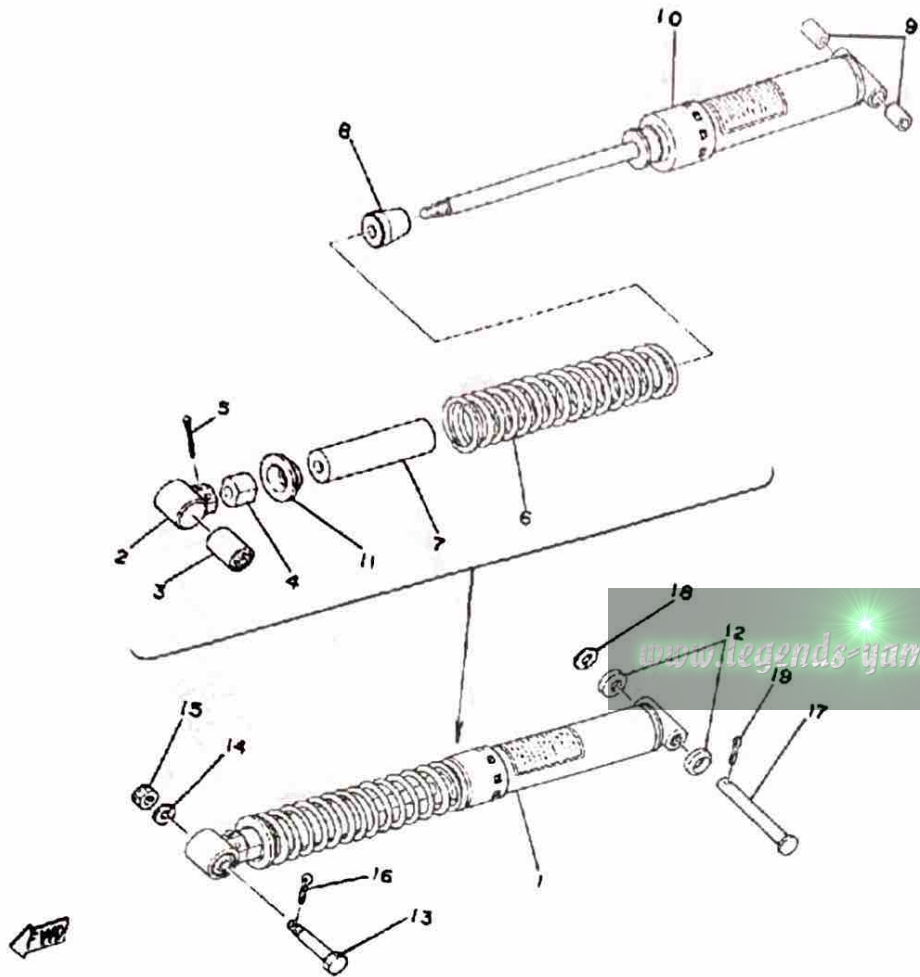

FRONT FORK

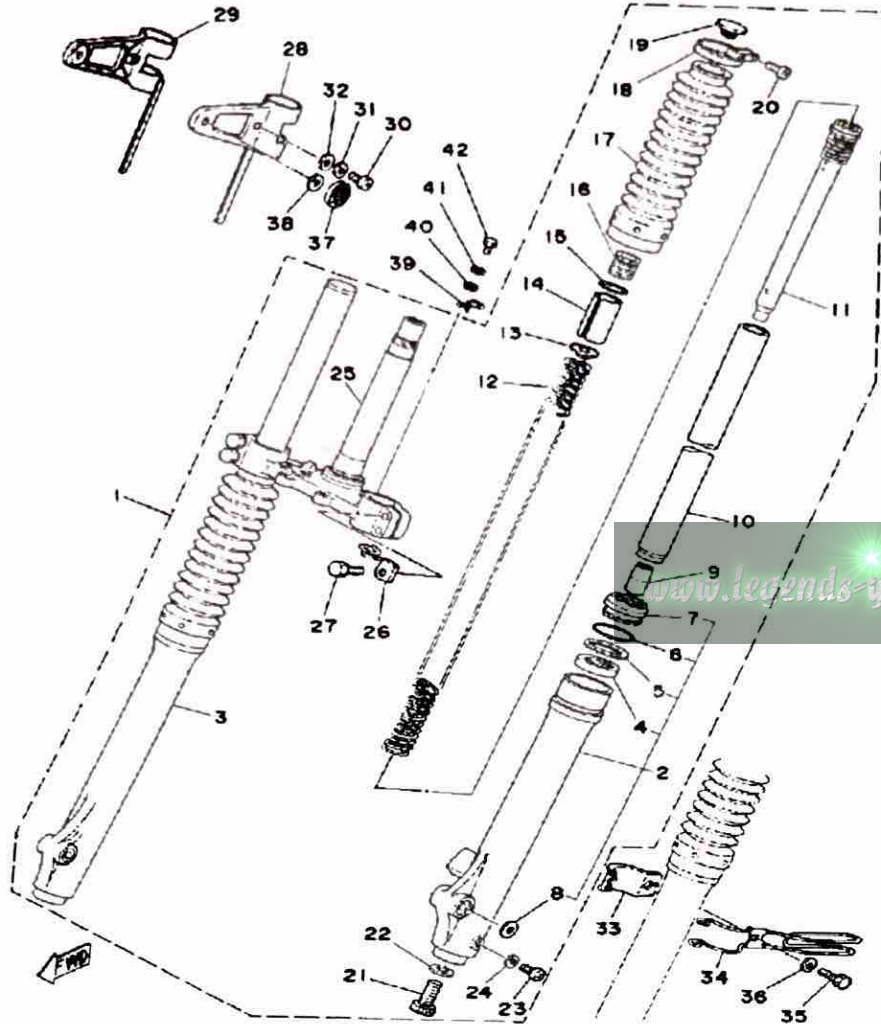

Ref. No.	Part Number	Description	Qty	Remarks
1	(2N4-23101-00-00)	FRONT FORK ASSEMBLY	1	
2	(2K5-23126-00-00)	TUBE, OUTER 1	1	
3	(2K5-23136-00-00)	TUBE, OUTER 2	1	
4	2K5-23145-00-00	.. OIL SEAL	2	
5	2K5-23146-00-00	.. WASHER, OIL SEAL	2	
6	15E-23153-00-00	.. RING, SNAP	2	
7	3Y6-23144-00-00	.. SEAL, DUST (2K5-23144-00)	2	
8	(2K5-23165-00-00)	WASHER, FELT	2	
9	2K5-23173-00-00	. SPINDLE, TAPER	2	
10	2N4-23110-00-00	. INNER TUBE 1	2	
11	(2K5-23170-00-00)	CYLINDER, FRTRFRK	2	
12	(2N4-23141-00-00)	SPRING, FRONT FORK	2	
13	256-23142-60-00	. SEAT, SPRING UPPER	2	
14	(256-23118-60-00)	SPACER	2	
15	146-23114-00-00	. GASKET	2	
16	1X0-23111-00-00	. BOLT, CAP	2	
17	2K5-23191-M0-00	. BOOT, FRONT FORK	2	
18	2K5-23192-00-00	. BAND	2	
19	1X0-23168-00-00	. CAP (2N4-23168-00)	2	
20	509-23194-L0-00	. SCREW, BOOT BAND	2	
21	278-23181-50-00	. BOLT, HEXAGON SOCKET HEAD	2	
22	509-23158-L0-00	. GASKET	2	
23	4H7-23119-00-00	. PLUG, DRAIN - (122-23119-01)	2	
	98580-04008-00	. SCREW, PAN HEAD	2	
24	122-23129-00-00	. GASKET, DRAIN PLUG	2	
25	(2N4-23340-00-33)	UNDER BRACKET	1	YAMAHA BLK
26	(2N4-23317-00-00)	HOLDER, CABLE	1	
27	5X6-23181-L0-00	. BOLT, HEX SCKT HEADSOCKET HEAD	4	

CONTINUED ON NEXT FRAME ►

FRONT FORK

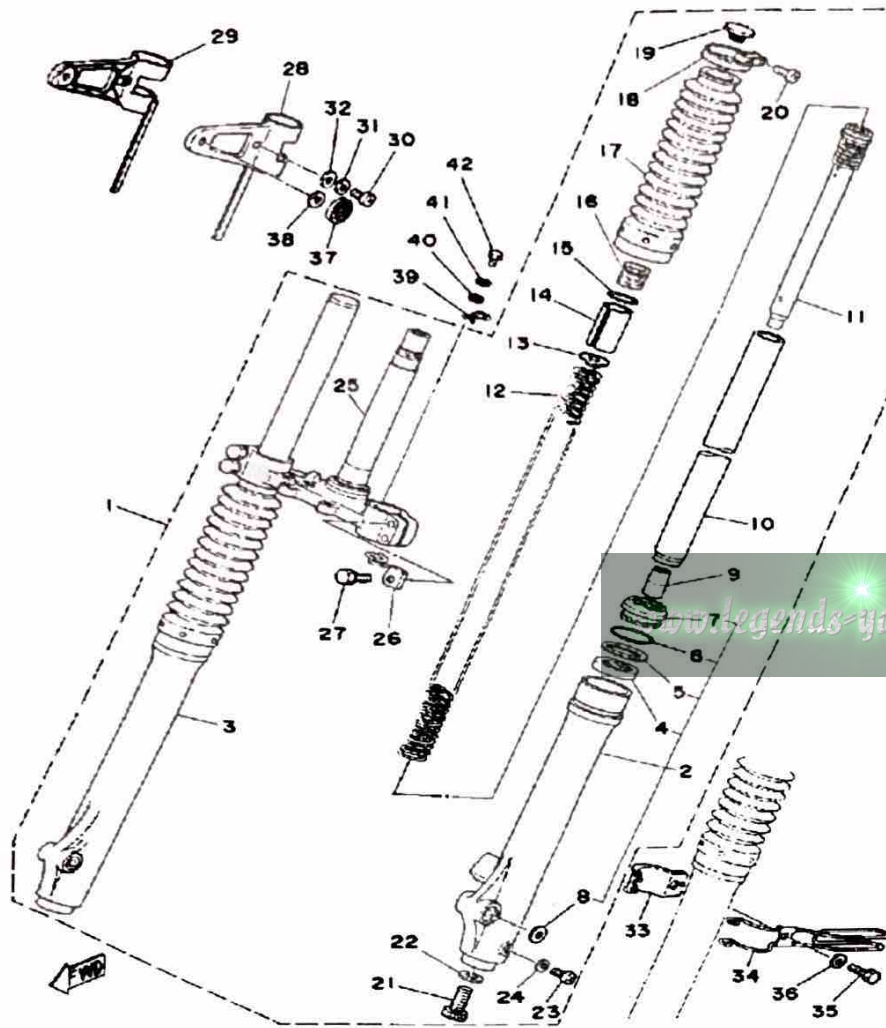

Ref. No.	Part Number	Description	Qty	Remarks
28	2N4-84118-00-00	STAY, HEADLIGHT 1	1	
29	2N4-84119-00-00	STAY, HEADLIGHT 2	1	
30	98580-06020-00	SCREW	2	
31	92995-06100-00	WASHER, SPRING	2	
32	92990-06200-00	WASHER	2	
33	2A6-23319-00-00	HOLDER, CABLE 2	1	
34	2A6-23318-00-00	HOLDER, CABLE 1	1	
35	97011-06025-00	BOLT (97001-06025)	1	
36	92990-06200-00	WASHER	1	
37	355-85111-01-00	REFLECTOR, FRONT 1	2	
38	90430-06012-00	GASKET	2	
39	2A-68359-50-0	UNAVAILABLE IN PRICE BOOK	1	
40	92901-06600-00	WASHER	1	
41	92995-06100-00	WASHER, SPRING	1	
42	97013-06012-00	BOLT	1	

OILTANK

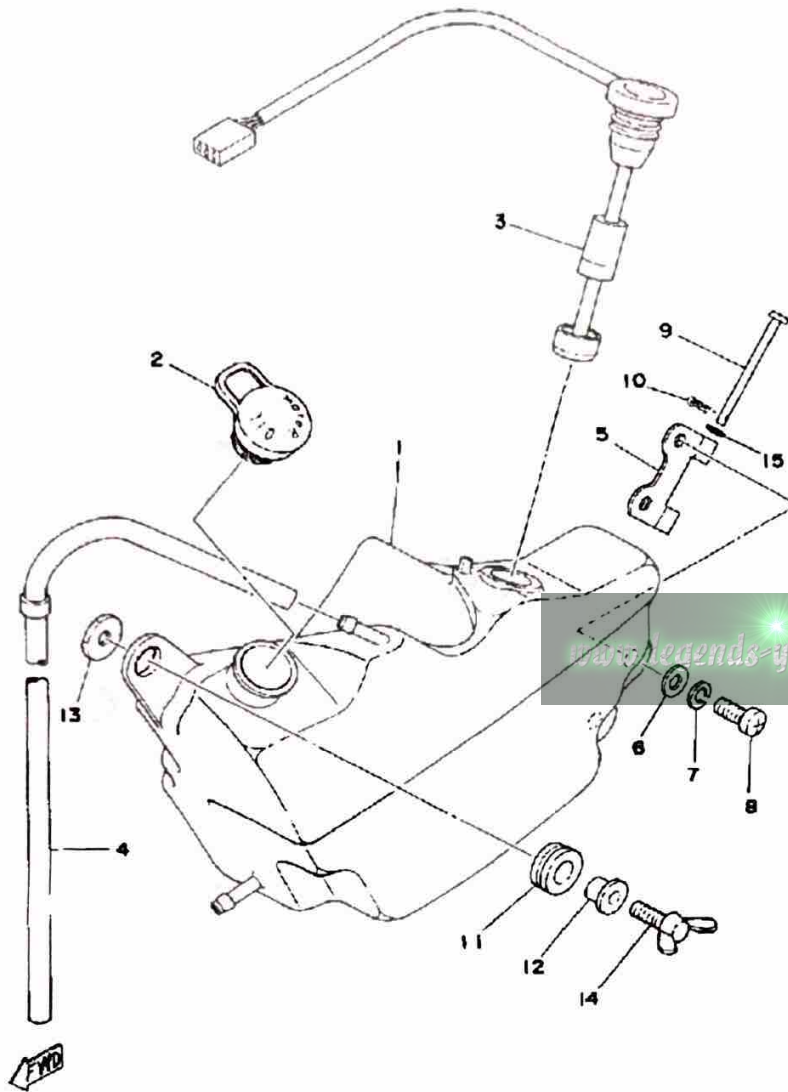

Ref. No.	Part Number	Description	Qty	Remarks
1	2A6-21751-00-00	TANK, OIL	1	
2	1T9-21771-00-00	BODY, CAP	1	
3	4L0-85720-00-00	OIL LVL GAUGE ASSEMBLY ..	1	
4	90445-09361-00	HOSE	1	
5	2A6-21796-00-00	HINGE	1	
6	90201-06067-00	WASHER, PLATE	2	
7	92995-06100-00	WASHER, SPRING	2	
8	98503-06014-00	SCREW, PAN HEAD (92502-06016)	2	
9	91701-05050-00	PIN, CLEVIS	1	
10	90468-10050-00	CLIP	1	
11	90480-14023-00	GROMMET	1	
12	90387-07391-00	COLLAR	1	
13	90179-06013-00	NUT, SPEC'L SHAPE	1	
14	90122-06021-00	BOLT, WING (38W)	1	
15	93210-04122-00	O-RING	1	

FUEL TANK

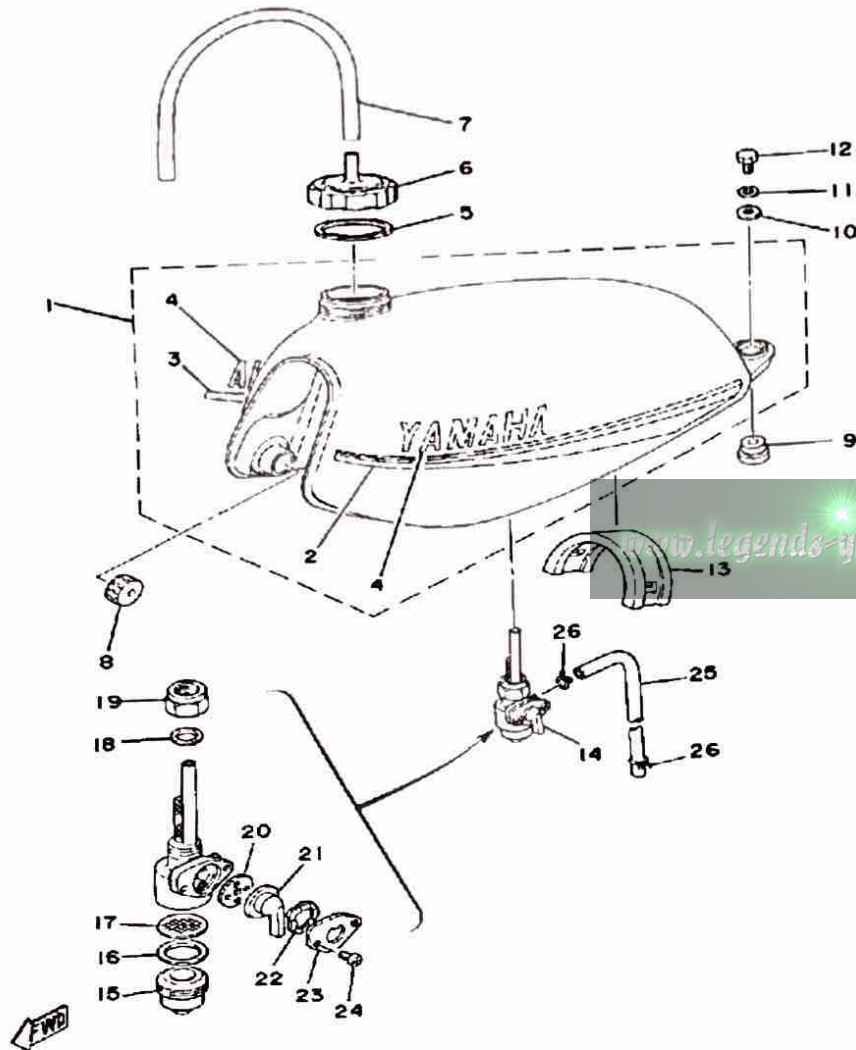

Ref. No.	Part Number	Description	Qty	Remarks
1	(2N4-24110-00-03)	FUEL TANK	1	CRYSTAL SILVER
	(2N4-24110-00-04)	FUEL TANK	1	SUNSHINE RED
2	(2N5-24244-00-00)	GRAPHIC, FUEL TNK 1	1	FOR SUNSHINE RED
	(2N5-24244-10-00)	GRAPHIC, FUEL TNK 1	1	FOR CRYSTAL SILVER
3	(2N5-24245-00-00)	GRAPHIC, FUEL TNK 2	1	FOR SUNSHINE RED
	(2N5-24245-10-00)	GRAPHIC, FUEL TNK 2	1	FOR CRYSTAL SILVER
4	99224-00035-00	. EMBLEM, YAMAHA	2	
5	1W1-24612-00-00	GASKET, CAP	1	
6	2A6-24611-00-00	BODY, CAP	1	
7	90445-09115-00	HOSE	1	
8	278-24181-00-00	DAMPER, LOCATING 1	2	
9	90480-22231-00	GROMMET	2	
10	90201-06073-00	WASHER, PLATE	2	
11	92995-06100-00	WASHER, SPRING	2	
12	97013-06012-00	BOLT	2	
13	2A6-24182-00-00	DAMPER, LOCATING 2	1	
14	304-24500-12-00	FUEL COCK ASSEMBLY 1 ...	1	
15	1A0-24521-01-00	. CUP, FILTER	1	
16	132-24522-00-00	. GASKET	1	
17	304-24515-00-00	. NET, FILTER 2	1	
18	434-24532-00-00	. GASKET	1	
19	132-24531-00-00	. NUT	1	
20	137-24523-00-00	. GASKET	1	
21	447-24524-00-00	. LEVER, COCK	1	
22	132-24518-00-00	. WASHER, WAVE	1	
23	447-24525-00-00	. PLATE, LEVER FITTING ...	1	
24	98580-03006-00	. SCREW, PAN HEAD	2	

CONTINUED ON NEXT FRAME ➤

FUEL TANK

Ref. No.	Part Number	Description	Qty	Remarks
25	90445-09089-00	HOSE	1	
26	90467-08003-00	CLIP	2	

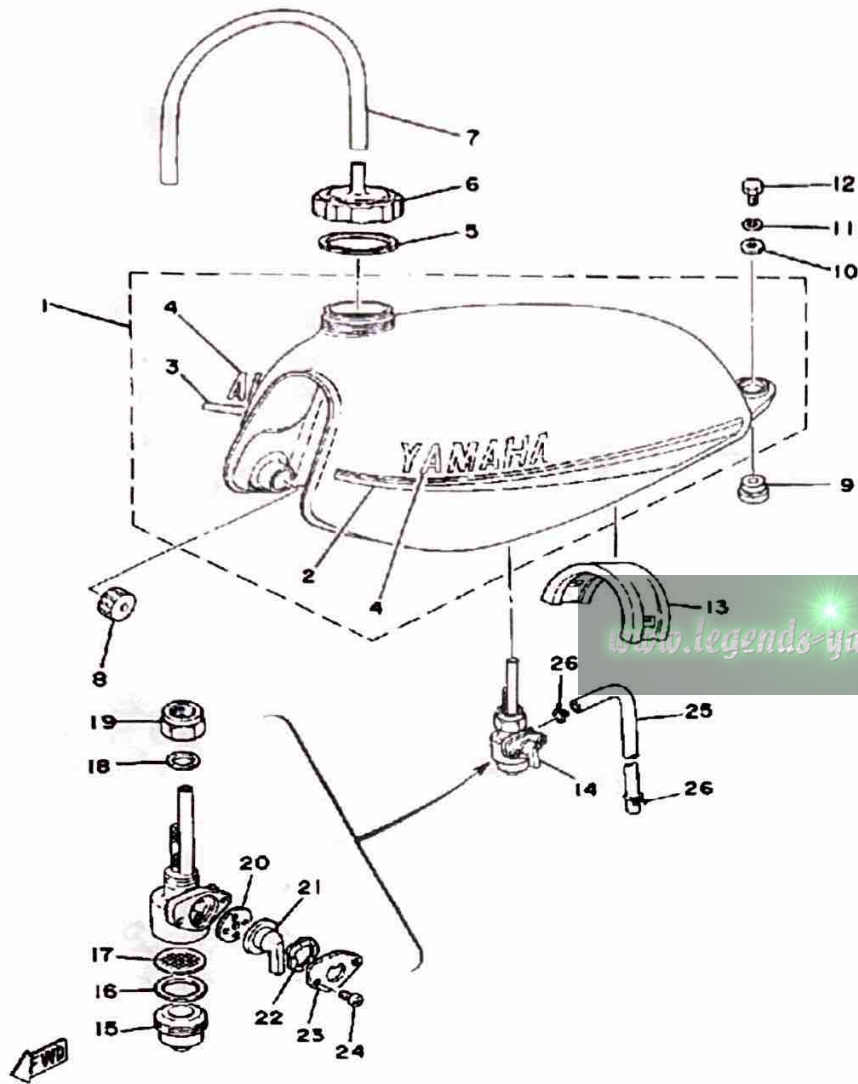

SEAT

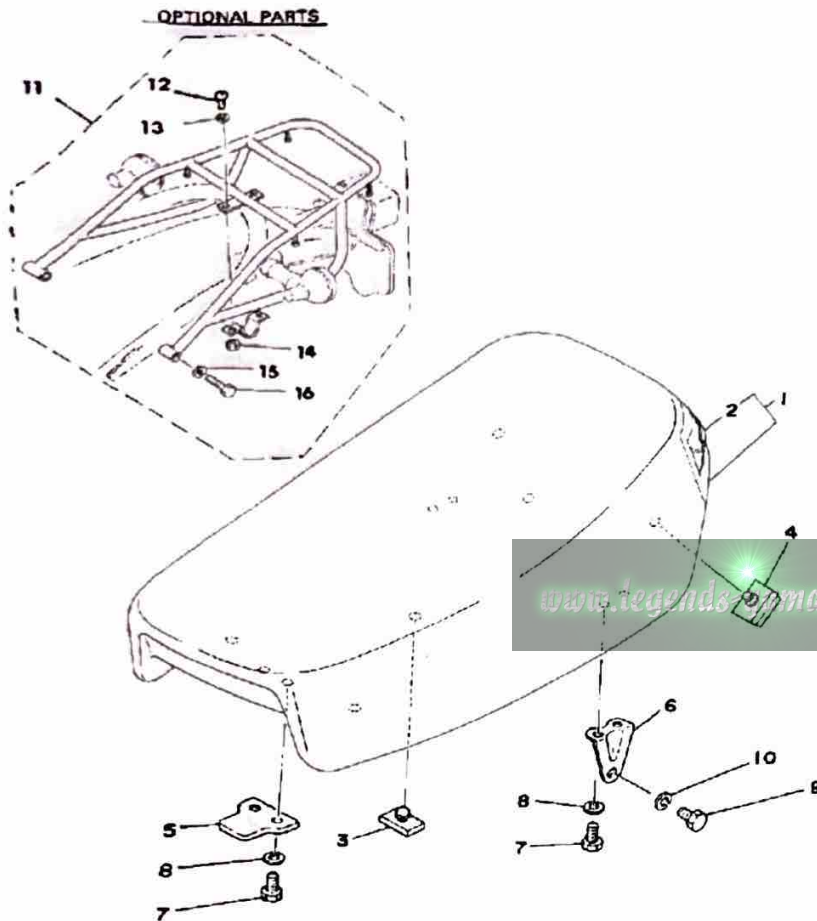

Ref. No.	Part Number	Description	Qty	Remarks
1	2N4-W2473-00-00	SEMI-DBL-SEAT ASSEMBLY (2N4-24770-90)	1	
2	2N4-24771-00-00	. COVER, SM-DBL SEAT	1	
3	509-24724-00-00	DAMPER, SEAT	4	
4	214-24724-00-00	DAMPER, SEAT	2	
5	1M1-24748-00-00	BRACKET, SEAT	1	
6	2A6-24738-00-00	BRACKET, SEAT	2	
7	97013-06012-00	BOLT	6	
8	92995-06100-00	WASHER, SPRING	6	
9	97313-08012-00	BOLT	2	
10	92990-08100-00	WASHER	2	
11	€90-89055-08-9	UNAVAILABLE IN PRICE BOOK	1	OPTIONAL PARTS
12	98501-05018-00	. SCREW, PAN HEAD	2	OPTIONAL PARTS
13	92990-05100-00	. WASHER, SPRING	2	OPTIONAL PARTS
14	95380-05600-00	. NUT	2	OPTIONAL PARTS
15	92990-08100-00	. WASHER	2	OPTIONAL PARTS
16	97313-08045-00	. BOLT	2	OPTIONAL PARTS

FW

FRONT WHEEL

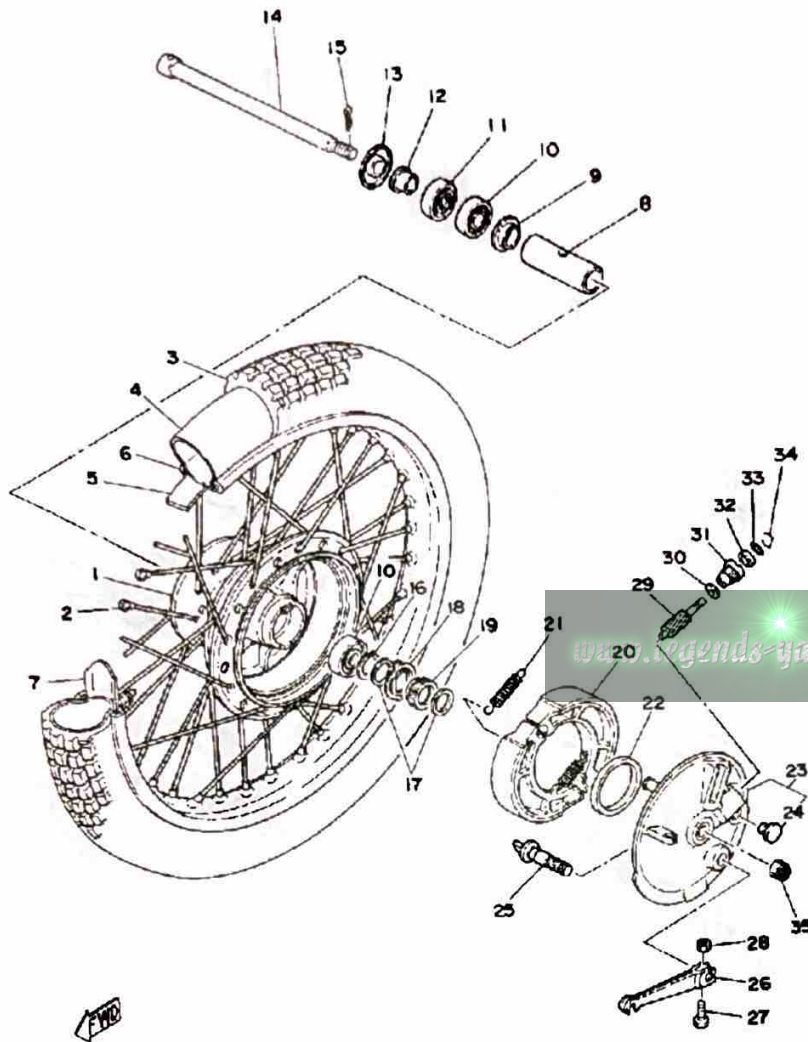

Ref. No.	Part Number	Description	Qty	Remarks
1	2A6-25111-00-98	HUB, FRONT	1	LOW GLOSS BLACK
2	2A6-25104-00-00	SPOKE SET, FRONT	1	
3	94127-212X0-00	TIRE (2.75-21)	1	
4	94227-21123-00	TUBE (2.75-21)	1	
5	94330-21084-00	BAND, RIM (3.00-21)	1	
6	94416-21206-00	RIM 1.60X21 (1.60-21) (94416-21312, B, +", F,)	1	
7	1T1-25194-00-00	SPACER, BEAD	1	
8	90560-12261-00	SPACER	1	
9	109-25315-00-00	FLANGE, SPACER	1	
10	93306-30109-00	BEARING	2	
11	93102-18008-00	OIL SEAL	1	
12	90387-12265-00	COLLAR (183-25183-00)	1	
13	2K5-25118-00-00	COVER, HUB DUST	1	
14	353-25381-00-00	AXLE, WHEEL	1	
15	91490-20020-00	PIN, COTTER	1	
16	99009-20400-00	CIRCLIP	1	
17	90201-20269-00	WASHER, PLATE	2	
18	183-25149-00-00	CLUTCH, METER	1	
19	37A-25135-00-00	GEAR, DRIVE	1	
20	437-W2536-00-00	BRAKESHOE SET-2PCS	2	
21	90506-17328-00	SPRING, TENSION	2	
22	93105-47007-00	OIL SEAL	1	
23	2N4-25016-01-98	BRAKE SHOE PLT ASSEMBLY (2N4-25120-00-98)	1	LOW GLOSS BLACK
24	90480-10068-00	GROMMET	1	
25	2RH-25351-00-00	CAMSHAFT	1	
26	5H0-25155-00-00	LEVER, CAMSHAFT 1	1	
27	90101-06278-00	BOLT	1	

CONTINUED ON NEXT FRAME ►

FRONT WHEEL

Ref. No.	Part Number	Description	Qty	Remarks
28	95380-06600-00	NUT	1	
29	37A-25138-00-00	GEAR, METER	1	
30	90201-07076-00	WASHER, PLATE	1	
31	109-25136-00-00	BUSH	1	
32	93104-07003-00	OIL SEAL	1	
33	93210-14104-00	O-RING	1	
34	102-25137-00-00	RING, STOP	1	
35	90171-10004-00	NUT, CASTLE	1	

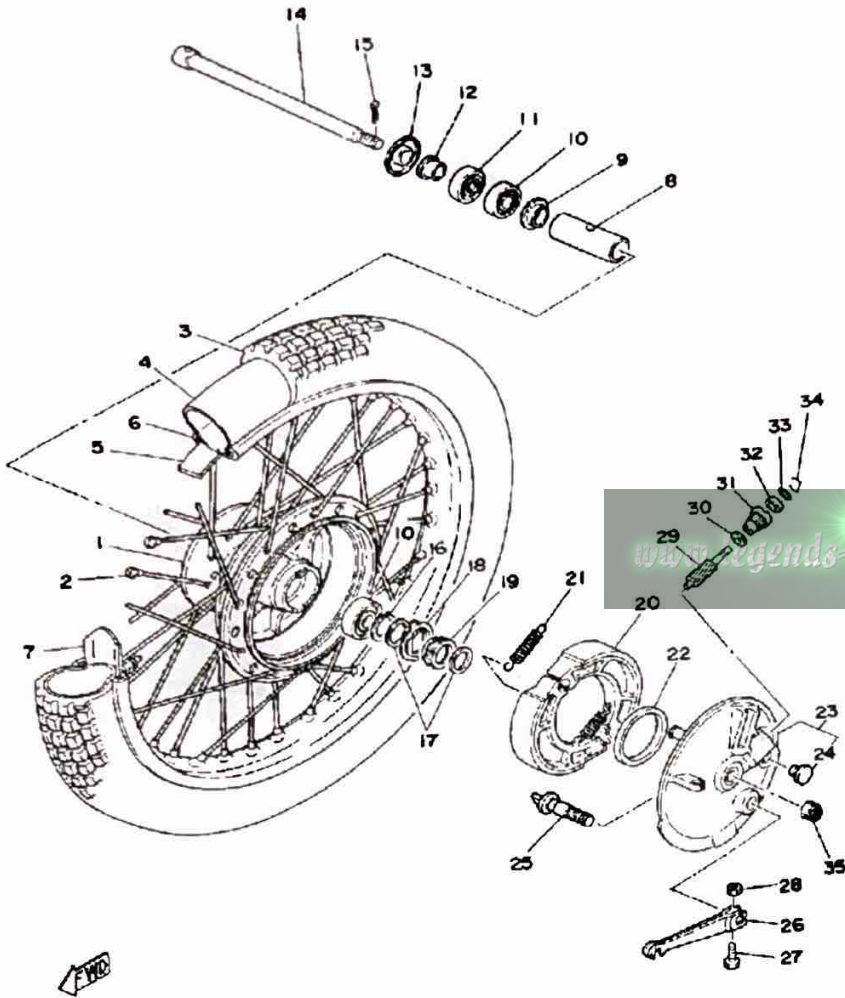

REAR WHEEL

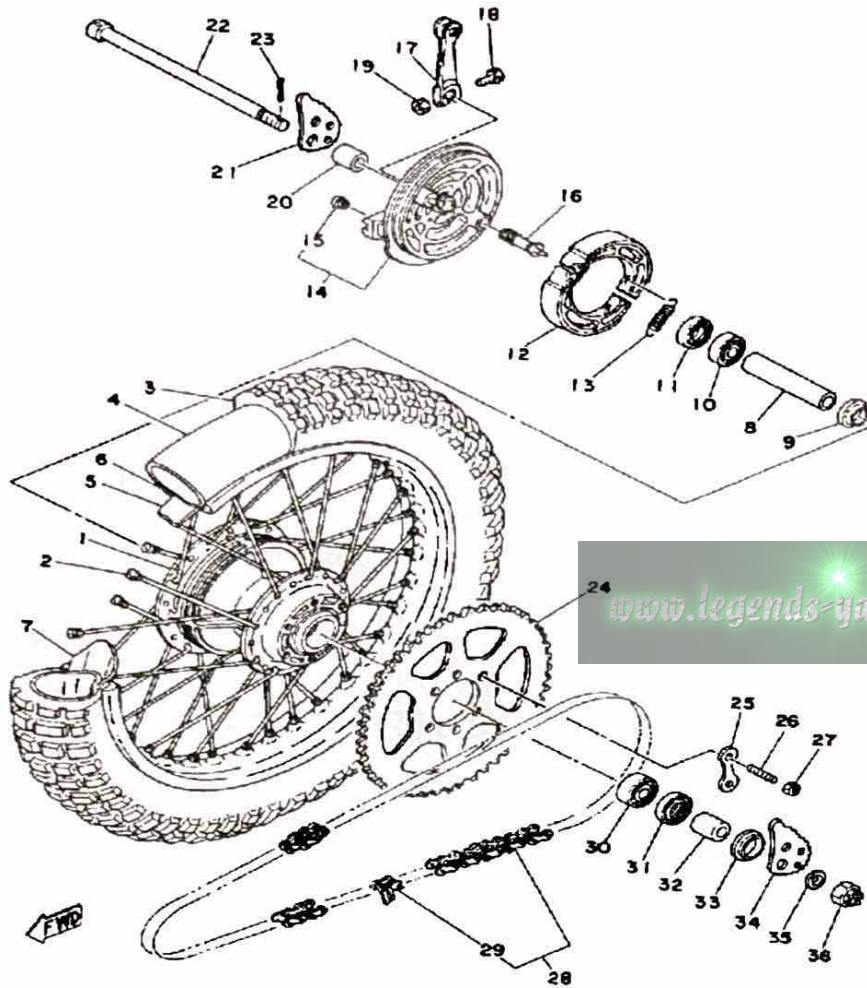

Ref. No.	Part Number	Description	Qty	Remarks
1	1W1-25311-00-98	HUB, REAR	1	LOW GLOSS BLACK
2	401-25304-20-00	COMPLETE REAR WHEEL SPOKE SET	1	
3	(94135-18378-00)	BS 350X18 T 5	1	
4	94232-18084-00	UNAVAILABLE IN PRICE BOOK (3.25-18)	1	
5	94345-18081-00	BAND, RIM (4.50-18)	1	
6	94418-18171-00	RIM 1.85X 8	1	
7	1T2-25394-00-00	SPACER, BEAD	1	
8	90560-15313-00	SPACER	1	
9	146-25115-00-00	FLANGE, SPACER 1	1	
10	93306-20204-00	BEARING (B6202Z)	1	
11	93104-22018-00	OIL SEAL	1	
12	437-W2536-00-00	BRAKESHOE SET-2PCS	2	
13	90506-17328-00	SPRING, TENSION	2	
14	99999-02024-00	BRAKE SHOE PLT ASSEMBLY (2A6-25026-00-98)BRAKE SHOE PLAT	1	LOW GLOSS BLACK
15	90480-10068-00	GROMMET	1	
16	2RH-25351-00-00	CAMSHAFT	1	
17	1E2-25155-00-00	LEVER, CAMSHAFT 1	1	
18	90101-06278-00	BOLT	1	
19	95380-06600-00	NUT	1	
20	90387-15524-00	COLLAR	1	
21	1W2-25389-01-00	PULLER, CHAIN 2	1	
22	5X3-25381-00-00	AXLE, WHEEL (2A6-25381-00-00)	1	
23	91401-30030-00	PIN, COTTER	1	
24	18L-25449-20-00	SPROCKET, DRVN 49T	1	WHEEL (49T)
25	1G8-25412-00-00	WASHER	3	

CONTINUED ON NEXT FRAME ►

REAR WHEEL

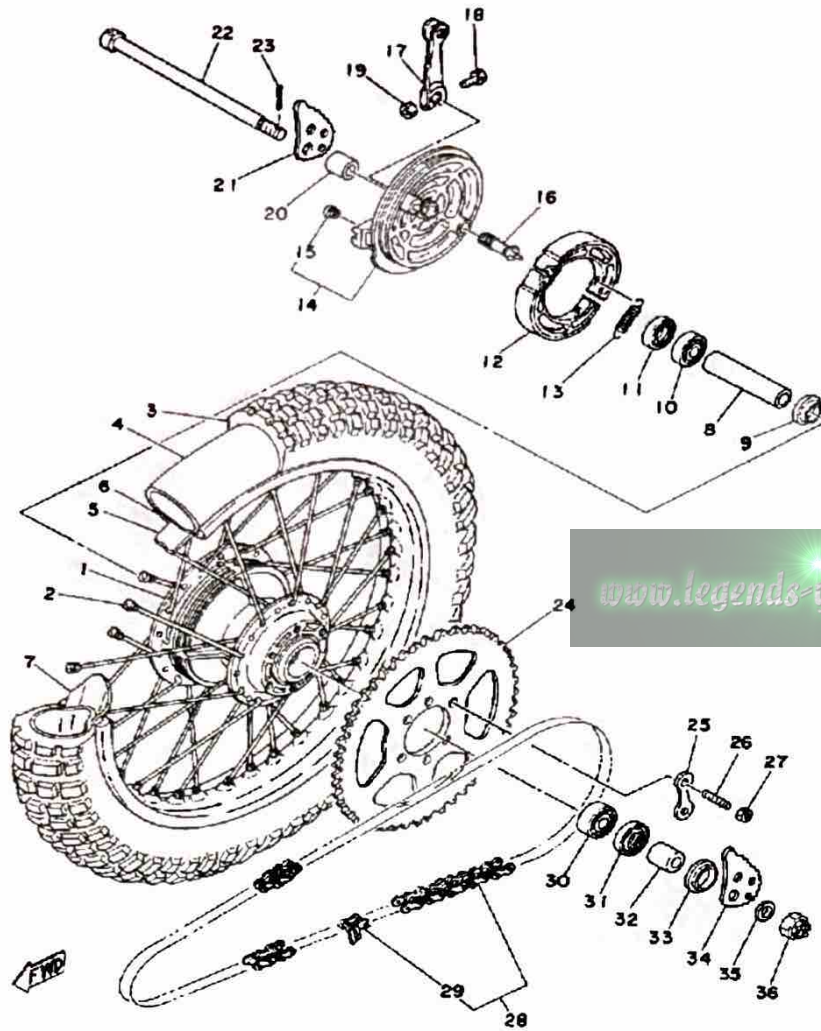

Ref. No.	Part Number	Description	Qty	Remarks
26	90116-10221-00	BOLT, STUD	6	
27	95701-10500-00	NUT, FLANGE (95702-10500) ..	6	
28	94580-33118-00	DID428DS-118L (94580-15118) .	1	
29	94680-15001-00	. JOINT CHAIN	1	
30	93306-30202-00	BEARING	1	
31	93106-26005-00	OIL SEAL	1	
32	90387-15524-00	COLLAR	1	
33	401-25367-00-00	COVER, HUB DUST	1	
34	1W2-25388-01-00	PULLER, CHAIN 1	1	
35	90201-15238-00	WASHER, PLATE	1	
36	90171-14020-00	NUT, CASTLE	1	

HANDLEBAR - CABLE

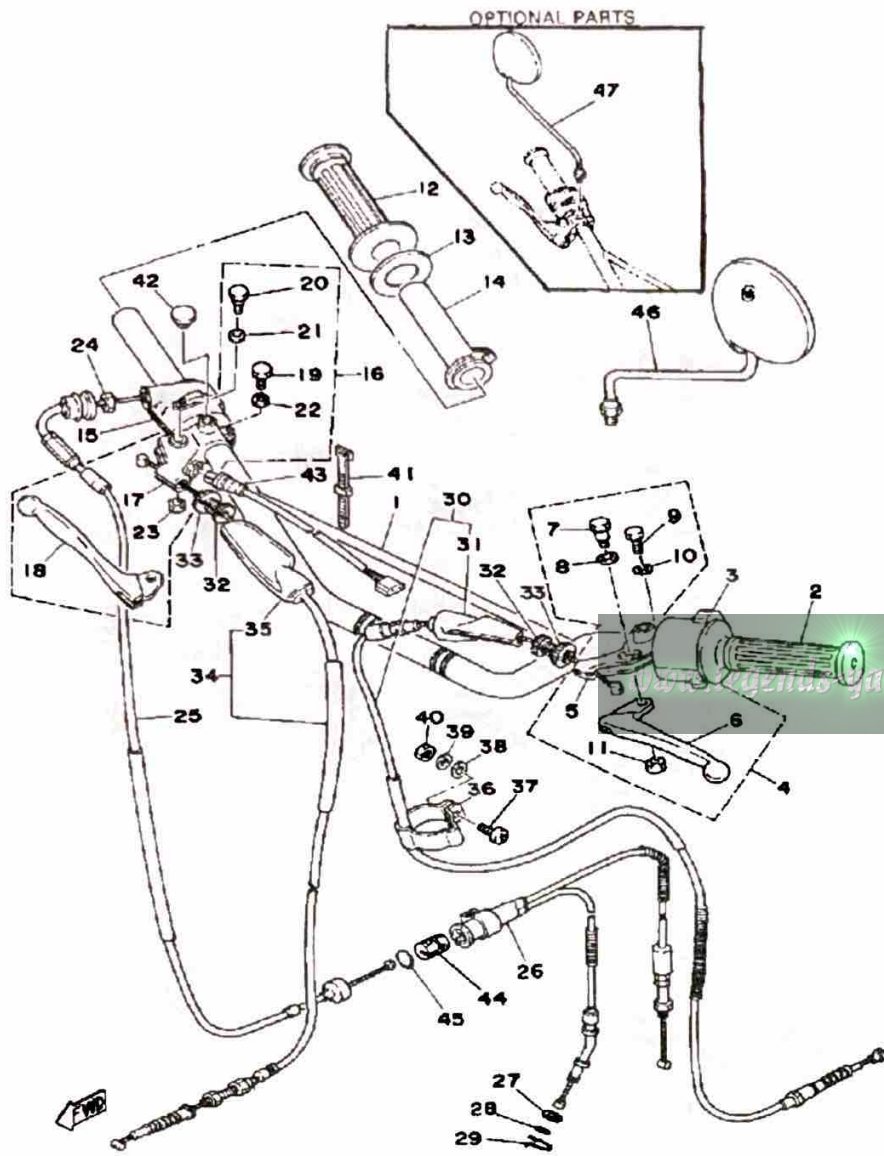

Ref. No.	Part Number	Description	Qty	Remarks
1	3G7-26111-00-00	HANDLEBAR	1	
2	1E6-26241-00-00	GRIP LH	1	
3	1M1-83973-50-00	SWITCH, HANDLE 3	1	
4	498-82910-20-00	LEVER HOLDER ASSEMBLY 1	1	
5	3Y6-82911-00-00	. HOLDER, LEVER 1	1	
6	1J3-83912-20-00	. LEVER L	1	
7	90109-06797-00	. BOLT	1	
8	90201-08083-00	. WASHER, PLATE	1	
9	97003-06022-00	. BOLT, HEXAGON (97301-06022)	1	
10	92995-06100-00	. WASHER, SPRING	1	
11	95601-06100-00	. NUT, U	1	
12	1A0-26242-01-00	GRIP (RIGHT)	1	
13	1M1-26249-01-00	RING, LEAF	1	
14	434-26243-00-00	TUBE, THROTTLE GUIDE	1	
15	1R6-83976-01-00	SWITCH, HANDLE 1	1	
16	2A6-W8292-01-00	LEVER HOLDER ASSEMBLY R (2A6-82920-90)	1	
17	361-82920-93-00	. HOLDER, LEVER 2 (36182-92131-00)	1	
18	2A6-83922-00-00	. LEVER R	1	
19	97003-06022-00	. BOLT, HEXAGON (97301-06022)	1	
20	90109-06797-00	. BOLT	1	
21	90201-08083-00	. WASHER, PLATE	1	
22	92995-06100-00	. WASHER, SPRING	1	
23	95601-06100-00	. NUT, U	1	
24	90170-10038-00	NUT, HEXAGON	1	
25	2A6-26311-00-00	CABLE, THROTTLE 1	1	
26	2A6-26312-00-00	CABLE, THROTTLE 2	1	

CONTINUED ON NEXT FRAME ►

HANDLEBAR - CABLE

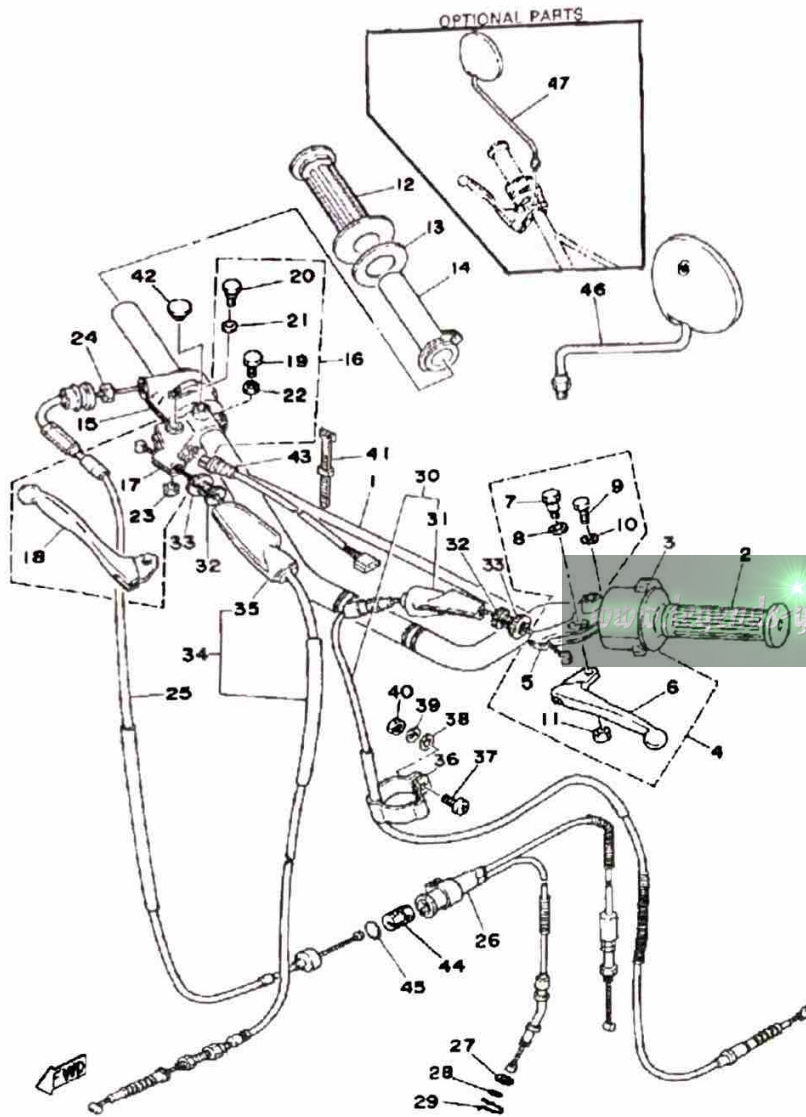

Ref. No.	Part Number	Description	Qty	Remarks
27	92901-08600-00	WASHER	1	
28	93210-07100-00	O-RING	1	
29	90468-08086-00	CLIP	1	
30	2A6-26335-01-00	CABLE, CLUTCH	1	
31	382-26372-01-00	COVER, HANDLE LEVER	1	
32	90123-08046-00	BOLT	2	
33	90179-08148-00	NUT	2	
34	2N4-26341-01-00	CABLE, BRAKE (1165MM)	1	
35	498-26372-00-00	COVER, HANDLE LEVER 1	1	
36	2A6-26397-00-00	CLAMP	1	
37	98501-05018-00	SCREW, PAN HEAD	1	
38	92901-05600-00	WASHER, PLATE	1	
39	92990-05100-00	WASHER, SPRING	1	
40	95380-05600-00	NUT	1	
41	437-83936-01-00	BAND, SWITCH CORD	4	
42	90338-09012-00	PLUG	1	
43	1M1-83980-30-00	STOP SWITCH ASSEMBLY	1	
44	1M1-26263-00-00	PIECE, CONNECTING	1	
45	93210-10118-00	O-RING	1	
46	1Y1-26290-10-00	MIRROR ASSEMBLY LH	1	CONVEX MIRROR
47	1Y1-26290-00-00	MIRROR ASSEMBLY RH	1	OPT. PART

STAND - FOOTREST - BRAKE PEDAL

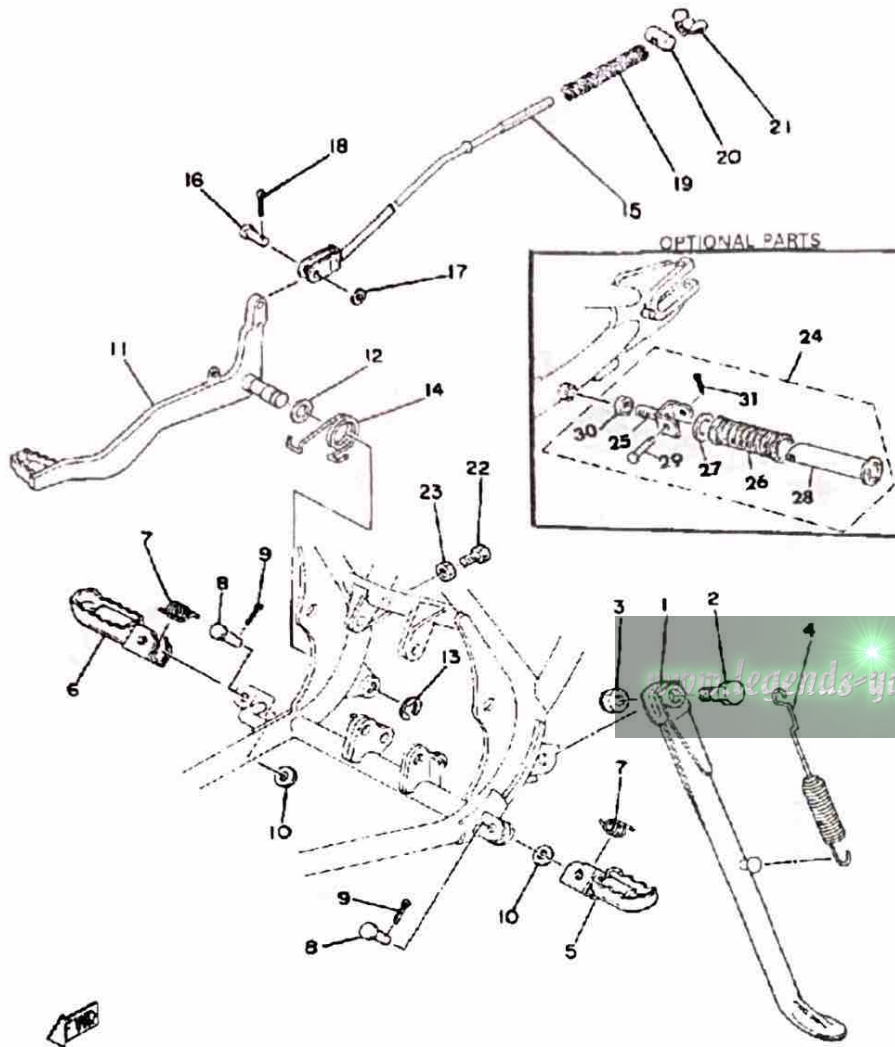

Ref. No.	Part Number	Description	Qty	Remarks
1	1W1-27311-10-00	STAND, SIDE	1	
2	90109-103A1-00	BOLT	1	
3	90185-10037-00	NUT, SELF-LOCKING	1	
4	90507-29008-00	SPRING, TENSION	1	
5	22W-27411-01-90	FOOTREST 1	1	YAMAHA BK
6	22W-27421-01-90	FOOTREST 2	1	YAMAHA BK
7	90508-20023-00	SPRING, TORSION	2	
8	91701-08038-00	PIN, CLEVIS	2	
9	91401-25020-00	PIN, COTTER	2	
10	92901-08600-00	WASHER	2	
11	2A6-27211-00-00	PEDAL, BRAKE	1	YAMAHA BK
12	90201-14212-00	WASHER, PLATE	1	
13	93430-10015-00	CIRCLIP, E-TYPE	1	
14	90508-32354-00	SPRING, TORSION	1	
15	322-27231-00-00	ROD, BRAKE	1	
16	90240-06006-00	PIN, CLEVIS	1	
17	92990-06200-00	WASHER	1	
18	91401-25020-00	PIN, COTTER	1	
19	90501-10245-00	SPRING, COMPRESSION	1	
20	90249-12008-00	PIN	1	
21	90179-06411-00	NUT	1	
22	97011-06020-00	BOLT	1	
23	95380-06700-00	NUT	1	
24	120-27430-02-00	RR FOOTREST ASSEMBLY 1 ..	2	
25	120-27432-02-00	. BRACKET 1	2	
26	120-27433-00-00	. COVER, REAR FOOTREST ..	2	
27	90201-20279-00	. WASHER, PLATE	2	
28	120-27431-00-00	. FOOTREST, REAR 1	2	
29	90240-06009-00	. PIN, CLEVIS	2	

CONTINUED ON NEXT FRAME ►

STAND - FOOTREST - BRAKE PEDAL

Ref. No.	Part Number	Description	Qty	Remarks
30	95301-12700-00	. NUT (95302-12700)	2	
31	91490-16020-00	. PIN, COTTER	2	

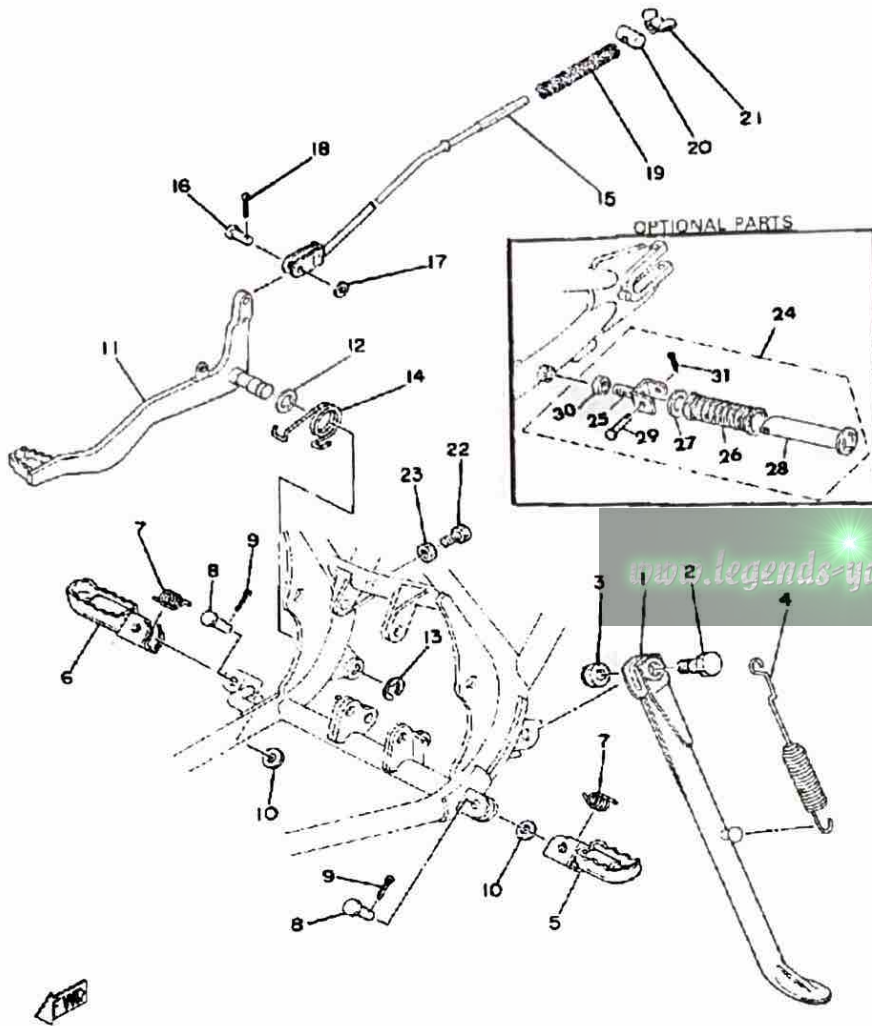

METER

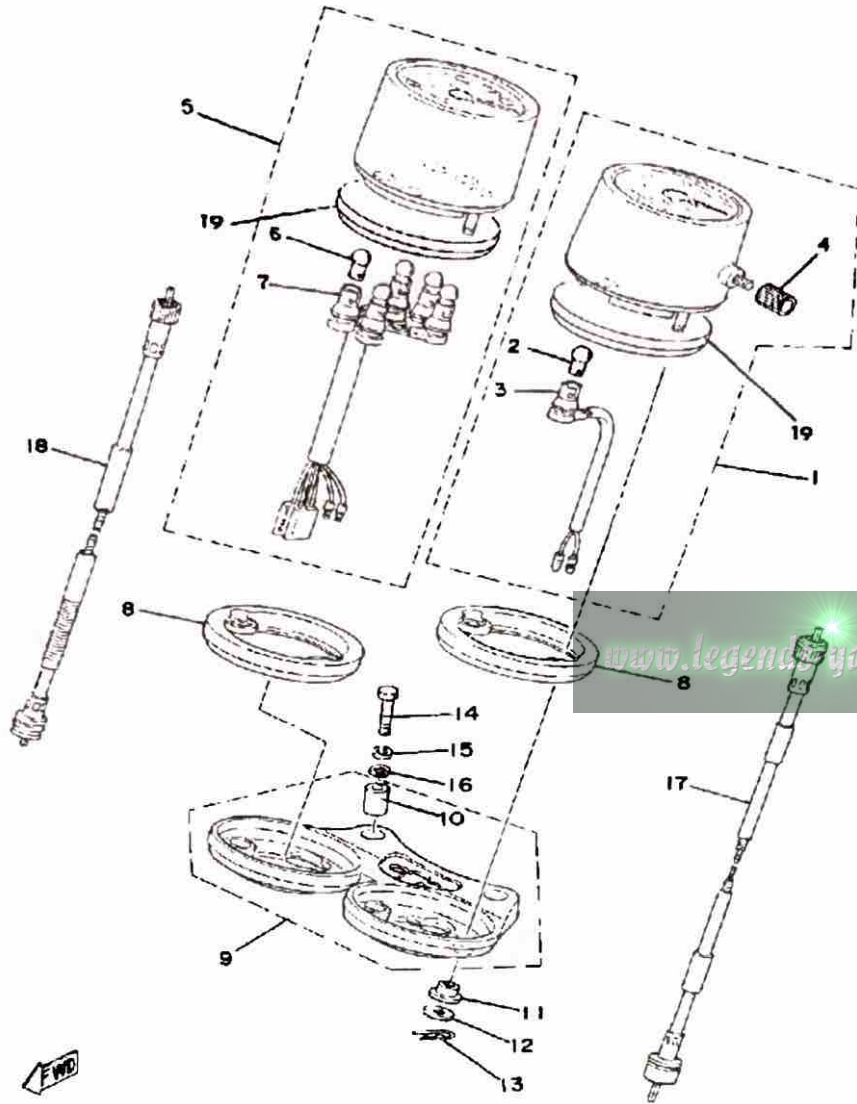

Ref. No.	Part Number	Description	Qty	Remarks
1	2N4-83570-A0-00	SPEEDOMETER ASSEMBLY ..	1	MILE/H
2	122-83516-10-00	. BULB (122-83516-10)	1	
3	(1V1-83536-00-00)	SOCKET, METER	1	
4	1E6-83578-10-00	. KNOB, TRIP METER	1	
5	2X1-83540-F0-00	. TACHOMETER ASSEMBLY (2N4-83540-00)	1	
6	122-83516-10-00	. BULB (122-83516-10)	5	
7	(2A6-83520-00-00)	SOCKET CORD ASSEMBLY ..	1	
8	2A6-83513-00-00	DAMPER	2	
9	2A6-83519-00-00	BRACKET, METER	1	
10	90385-06001-00	. BUSH, SPEC'L RUBBER (214-83528-00)	2	
11	1M1-83526-00-00	DAMPER 2	4	
12	90201-05033-00	WASHER, PLATE	4	
13	90468-10050-00	CLIP	4	
14	97021-06030-00	BOLT	4	
15	92995-06100-00	WASHER, SPRING	2	
16	92901-06600-00	WASHER	2	
17	1M1-83550-01-00	SPEEDOMETER CABLE (3H6-83550-00)	1	
18	2A6-83560-00-00	TACHOMETER CABLE	1	
19	2A6-83506-00-00	RING, METER COVER	2	

HEADLIGHT

Ref. No.	Part Number	Description	Qty	Remarks
1	1M1-84130-60-30	UNAVAILABLE IN PRICE BOOK (1M1-84130-60-33)	1	LOW GLOSS BLACK
2	498-84145-60-00	. COLLAR, BODY FITTING	2	
3	498-84163-60-00	. DAMPER	2	
4	1M1-84164-60-00	. DAMPER	2	
5	UNA-VAILA-BL-EI 0 0			
6	1M1-84195-61-00	. RING, RETAINING	1	
7	2A6-84120-60-00	. LENS ASSEMBLY	1	
8	341-84397-61-00	. COVER, SOCKET	1	
9	371-84312-60-00	. SOCKET	1	
10	1M1-84124-60-00	. SPRING, SET	3	
11	1M1-84133-60-00	. COLLAR, SCREW	1	
12	498-84128-60-00	. SPACER	1	
13	1M1-84137-60-00	BOLT, SPECIAL	1	
14	90109-08448-00	BOLT	2	
15	95333-08600-00	NUT	2	
16	92990-08100-00	WASHER	2	
17	92990-08200-00	WASHER, PLAIN	2	

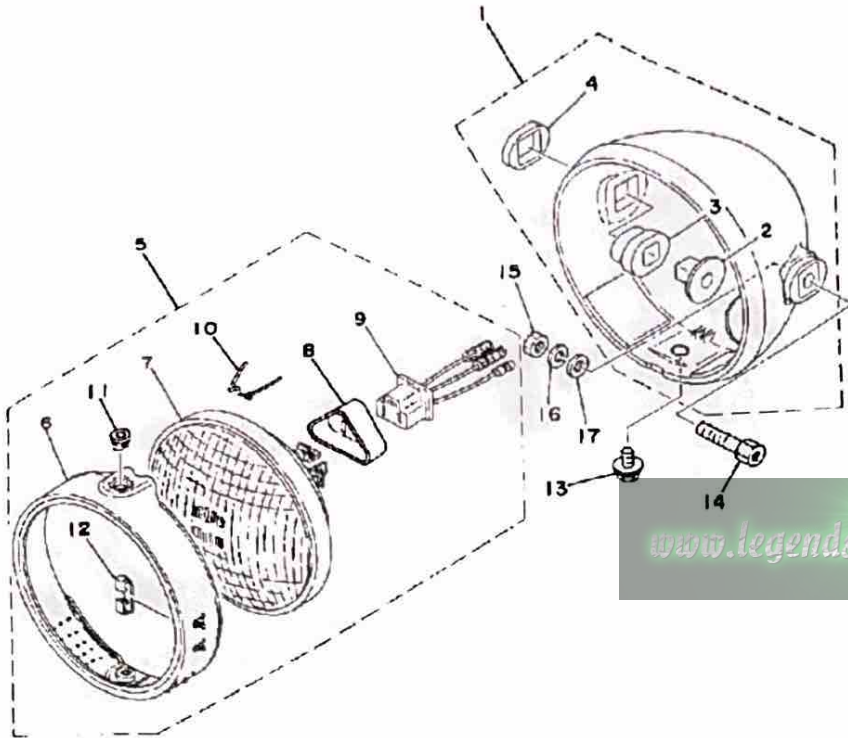

TAILLIGHT

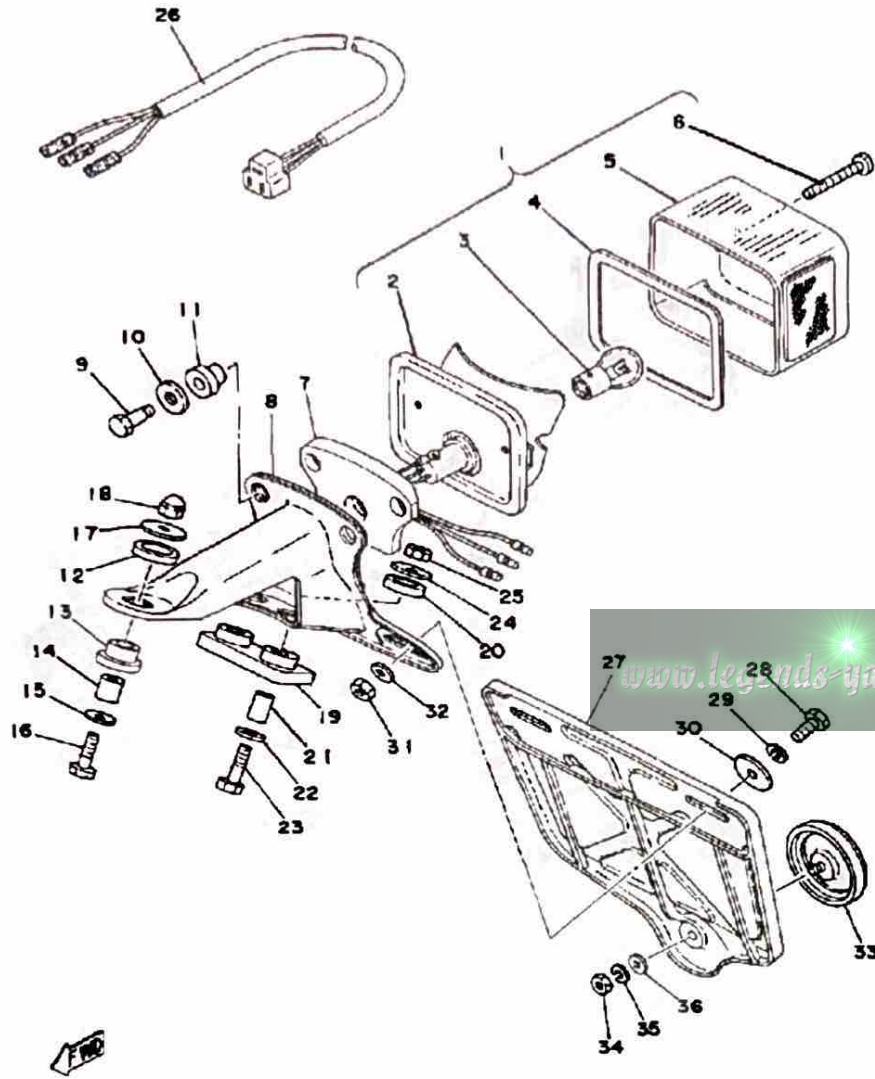

Ref. No.	Part Number	Description	Qty	Remarks
1	1M1-84510-60-00	TAILLIGHT UNIT ASSEMBLY ..	1	
2	1M1-84511-60-00	. BASE, TAILLIGHT	1	
3	1M1-84514-60-00	. BULB	1	
4	1M1-84523-60-00	. GASKET, LENS	1	
5	1M1-84521-60-00	. LENS, TAILLIGHT	1	
6	1M1-84524-60-00	. SCREW, LENS FITTING	2	
7	1M1-84512-60-00	SEAT, BASE	1	
8	2A6-84551-60-33	BRACKET, LICENCE	1	YAMAHA BK
9	1M1-84526-60-00	SCREW	2	
10	2H7-84754-00-00	WASHER, SPECIAL	2	
11	1M1-84527-60-00	DAMPER	2	
12	1M1-84553-10-00	DAMPER	1	
13	1M1-84553-20-00	DAMPER	1	
14	90387-06553-00	COLLAR	1	
15	92901-06600-00	WASHER	1	
16	97011-06025-00	BOLT (97001-06025)	1	
17	90201-06074-00	WASHER, PLATE	1	
18	95303-06800-00	NUT (CROWN)	1	
19	1M1-84553-00-00	DAMPER	1	
20	1M1-84553-10-00	DAMPER	2	
21	90387-06554-00	COLLAR	2	
22	90201-06067-00	WASHER, PLATE	2	
23	97013-06035-00	BOLT	2	
24	90201-06074-00	WASHER, PLATE	2	
25	95380-06600-00	NUT	2	
26	1M1-84517-00-00	CORD, TAILLIGHT	1	
27	1M1-85132-62-00	BRACKET, REFLECT 1	1	
28	97313-06016-00	BOLT, HEXAGON	2	
29	92995-06100-00	WASHER, SPRING	2	

CONTINUED ON NEXT FRAME ►

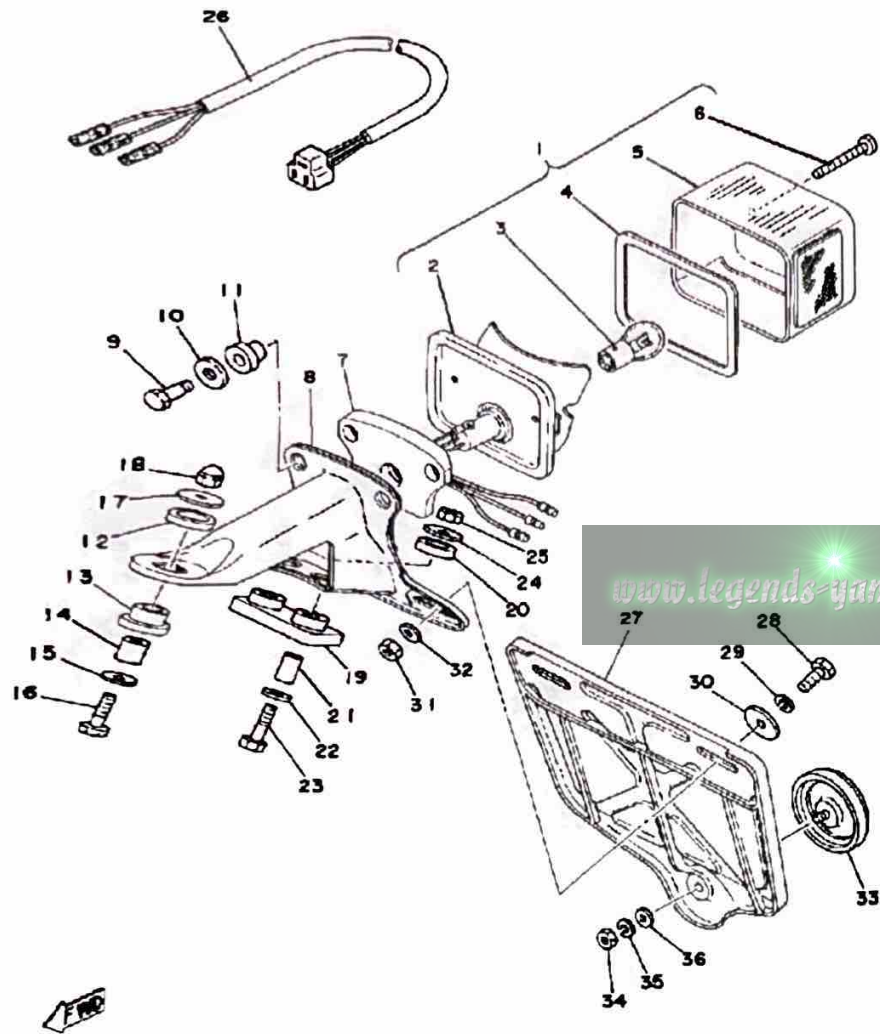

TAILLIGHT

Ref. No.	Part Number	Description	Qty	Remarks
30	90201-06074-00	WASHER, PLATE	2	
31	95380-06600-00	NUT	2	
32	92990-06600-00	WASHER, PLATE	2	
33	1M1-85131-10-00	REFLECTOR, REAR 1	1	UR
	449-85131-02-00	REFLECTOR, REAR 1	1	UR
34	95380-05600-00	NUT	1	
35	92990-05100-00	WASHER, SPRING	1	
36	92990-05200-00	WASHER, PLAIN	1	

TURNSIGNAL

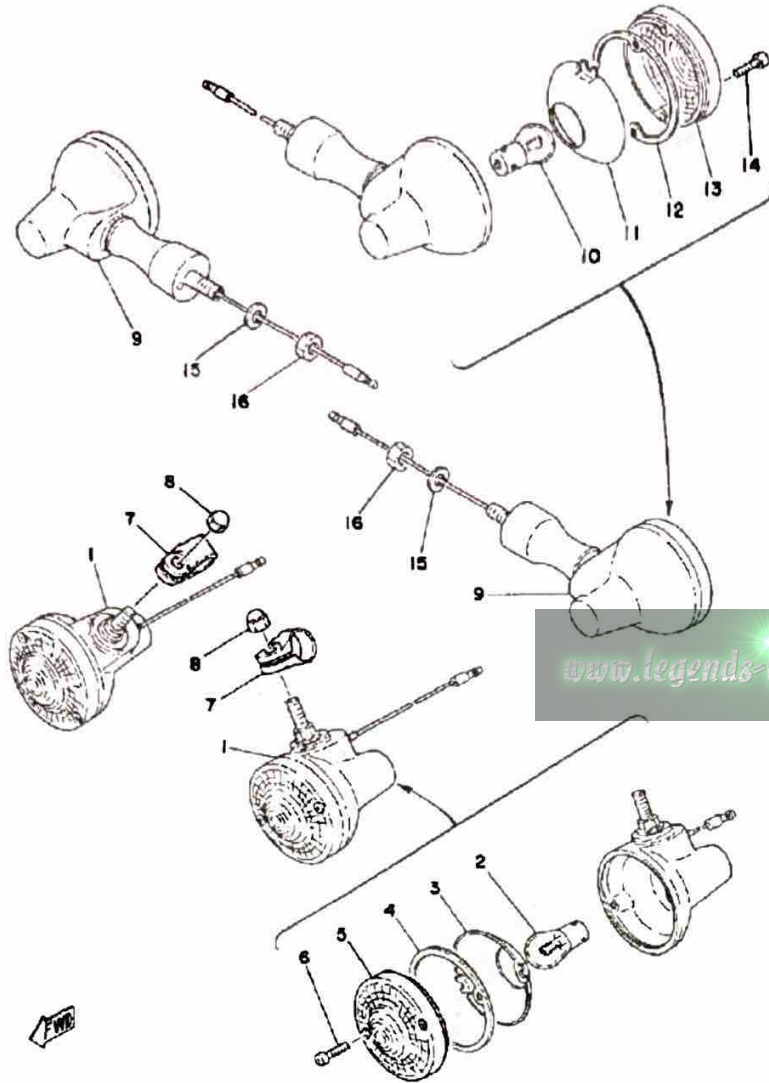

Ref. No.	Part Number	Description	Qty	Remarks
1	1M1-83310-60-00	FRT FLSHR LITE ASSEMBLY ASS'Y 1	2	
2	115-83311-60-00	. BULB, FLASHER	2	
3	1M1-83309-60-00	. REFLECTOR	2	
4	1M1-83313-60-00	. GASKET, FLSHR LENS	2	
5	341-83312-70-00	. LENS, FLASHER	2	
6	97780-30120-00	. SCREW, PANHEAD TAP	4	
7	1M1-83318-00-00	STAY, FLASHER 1	2	
8	95303-08800-00	NUT (CROWN) (95301-08800)	2	
9	1T9-83330-60-00	R FLSHR LITE ASSEMBLY	2	
10	115-83311-60-00	. BULB, FLASHER	2	
11	1M1-83309-60-00	. REFLECTOR	2	
12	1M1-83313-60-00	. GASKET, FLSHR LENS	2	
13	341-83312-70-00	. LENS, FLASHER	2	
14	97780-30120-00	. SCREW, PANHEAD TAP	4	
15	92990-10100-00	WASHER, SPRING	2	
16	95303-10600-00	NUT (95301-10600)	2	

ELECTRICAL

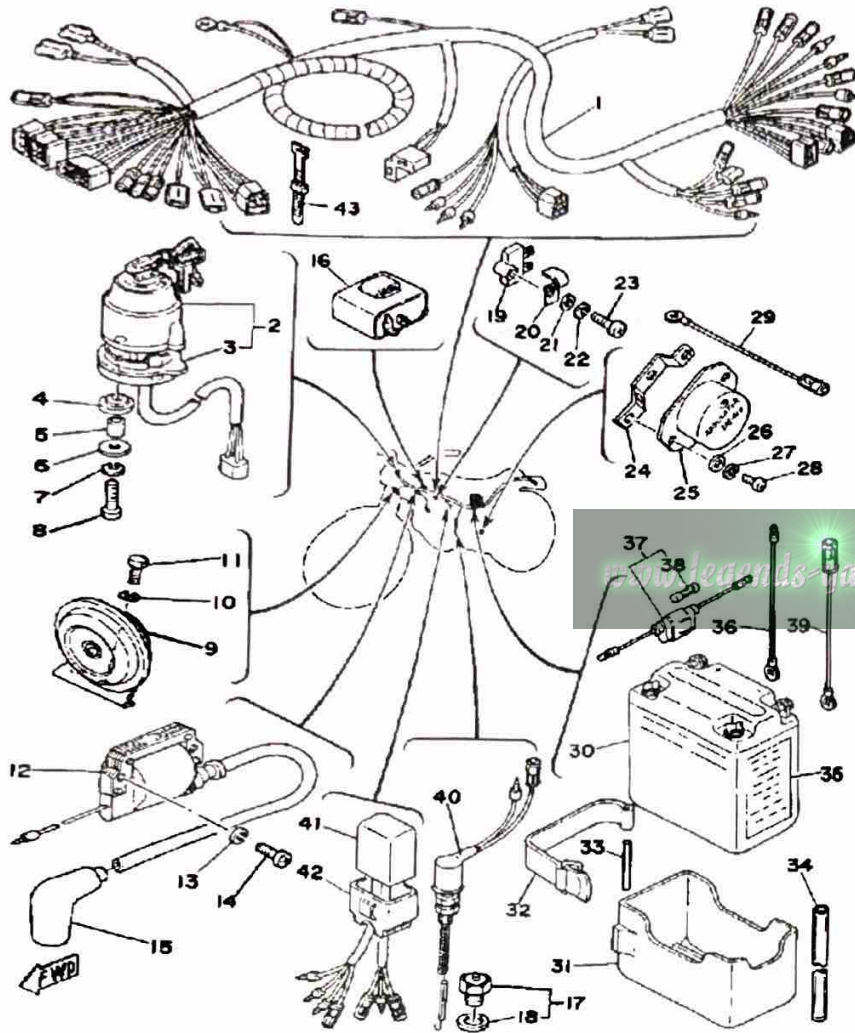

Ref. No.	Part Number	Description	Qty	Remarks
1	(2N5-82590-50-00)	WIRE HARNESS ASSEMBLY		
	01	1	
2	443-82508-21-00	MAIN SWITCH ASSEMBLY	1	
3	1M1-82555-00-00	DAMPER, MAIN SWCH 1	1	
4	1M1-82556-00-00	DAMPER, STOPPER	2	
5	437-82516-00-00	COLLAR, MAIN SWITCH	2	
6	90201-05033-00	WASHER, PLATE	2	
7	92990-05100-00	WASHER, SPRING	2	
8	98503-05025-00	SCREW, PAN HEAD (98501-05025)	2	
9	3Y1-83371-10-00	HORN	1	
10	92995-06100-00	WASHER, SPRING	2	
11	97013-06012-00	BOLT	2	
12	5G4-82310-40-00	IGNITION COIL ASSEMBLY (J17-82310-21)	1	
13	92995-06100-00	WASHER, SPRING	2	
14	98580-06020-00	SCREW	2	
15	512-82370-10-00	PLUG CAP ASSEMBLY	1	AP
	56J-82370-00-00	PLUG CAP ASSEMBLY	1	
16	3BK-83350-00-00	FLASHER RELAY ASSEMBLY	1	
17	136-82540-00-00	NEUTRAL SWITCH ASSEMBLY	1	
18	37R-82543-00-00	GASKET	1	
19	1M1-81970-60-00	RECTIFIER ASSEMBLY	1	
20	90462-05005-00	CLAMP	1	
21	92901-05600-00	WASHER, PLATE	1	
22	92990-05100-00	WASHER, SPRING	1	
23	98580-05020-00	SCREW, PAN HEAD	1	
24	2A6-81915-00-00	PLATE, REG FITTING	1	
25	443-81910-62-00	VOLTAGE REG ASSEMBLY (498-81910-23)	1	

CONTINUED ON NEXT FRAME ►

ELECTRICAL

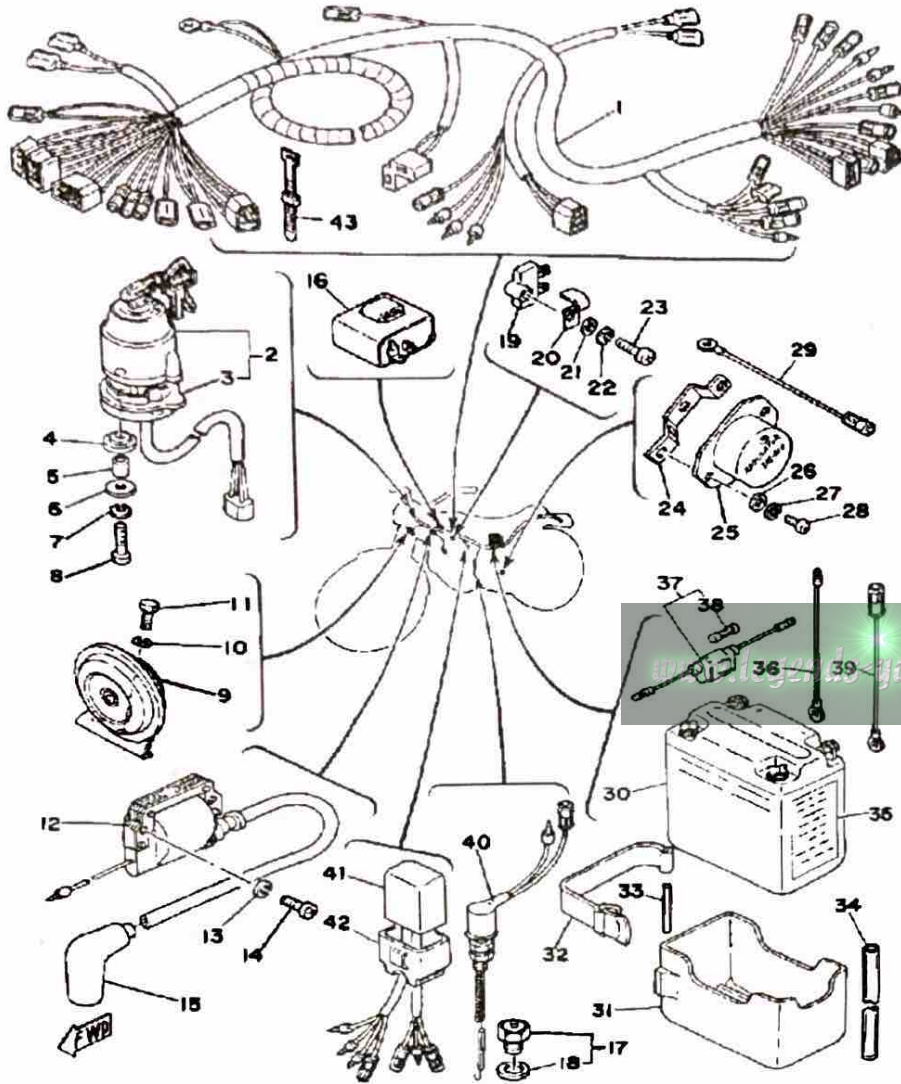

Ref. No.	Part Number	Description	Qty	Remarks
26	92901-05600-00	WASHER, PLATE	3	
27	92990-05100-00	WASHER, SPRING	3	
28	97313-05012-00	BOLT, HEXAGON	3	
29	142-83346-00-00	UNAVAILABLE IN PRICE BOOK	1	
30	BTY-6N63B-10-00	YUASA 6N6-3B-1 (1E6-82110-29)	1	
31	(2A6-82122-00-00)	SEAT, BATTERY	1	
32	2A6-82131-00-00	BAND, BATTERY	1	
33	91401-30040-00	PIN, COTTER	1	
34	(90445-08357-00)	HOSE	1	
35	118-82141-09-00	LABEL, BATTERY	1	
36	J42-82313-00-00	UNAVAILABLE IN PRICE BOOK (2A6-82115-00)	1	
37	55K-82150-01-00	FUSE HOLDER ASS'Y (55K-82150-00-00)	1	
38	116-82151-00-00	FUSE (10A)	1	
39	1H2-83346-00-00	CORD (1M1-82519-00)	1	
40	371-82530-03-00	STOP SWITCH ASSEMBLY ...	1	
41	2A7-85540-20-00	CDI UNIT ASSEMBLY	1	
42	2A7-85546-00-00	BAND	1	
43	437-82936-00-00	UNAVAILABLE IN PRICE BOOK	4	

GASKET KIT

Ref. No.	Part Number	Description	Qty	Remarks
43	18G-11351-01-00	. GASKET, CYLINDER	1	
	18G-15451-01-00	. GASKET, CRCS. COVER	1	
	1W2-11181-00-00	. GASKET, CYLINDER HEAD 1	1	
	2A6-15455-01-00	. GASKET 1	1	
	2A6-15456-00-00	. GASKET, O/PMP CVR 1	1	
	87A-13621-00-00	. GASKET, VALVE SEAT	1	
	93210-180A6-00	. O-RING	1	
	ø2A-70000-02-0-	UNAVAILABLE IN PRICE BOOK	1	

www.legends-yamaha-enduros.com

DT175F 1979 SERVICE DATA

MOTORCYCLE
M8-044

MODEL - IBM I.D. NUMBER	DT175F-R	DT175F-S	2N5
Initial Engine Number/Frame Number	2N5-000101 / 2N5-000101		
Basic Color(s)	Sunshine Red (R) Crystal Silver (S)		
Fuel Type/Fuel Tank Capacity/Reserve Capacity	Regular / 6.8 Lit. (1.8 Gal.) / 0.9 Lit. (0.2 Gal.)		
Dry Vehicle Weight	98 kg (216 lbs.)		
ENGINE TYPE	2-Stroke, Air-Cooled, Reed Valve		
Bore/Stroke/Number Cylinders/Displacement (cc)	66mm / 50mm / 1 / 171cc		
Compression Ratio/Compression Pressure min ~ max	10.1:1 (6.8:1 Corrected) / ϕ		
Piston Skirt Clearance new/max.	0.040 ~ 0.045mm / 0.1mm		
Ring End Gap top/2nd/3rd	0.3 ~ 0.5mm / 0.3 ~ 0.5mm / ϕ		
Valve Clearance (cold) Intake/Exhaust	ϕ		
Oil Pressure hot/rpm	ϕ		
Oiling System	Autolube		
Capacity: Dry	1.0 Lit.		
Oil and Filter Change	ϕ		
Oil Change	ϕ		
Lubricant: Temp above 5°C (40°F)	Yamalube 2* or Equivalent		
Below 15°C (60°F)	Yamalube 2* or Equivalent		
AUTOLUBE - Min. Stroke/Color Code	0.18 ~ 0.27mm / Gray		
Minimum Output @ 200 cycles	0.50cc		
Maximum Output @ 200 cycles	5.16cc		
CARBURETOR - Mfr./Type/I.D. Number	Mikuni / VM24SS / 2N500		
Main Jet/Pilot Jet	140 / 20		
Needle Jet/Jet Needle-Clip Position	N-4 / 5J11-4		
Side Cutaway or Throttle Valve	2.0		
Float Level	21.0 ± 1mm		
Idle RPM	1350 ~ 1500 rpm		
CO % @ Idle (Diagnostic Use Only)	7% or Less		
SUSPENSION			
Front Forks: Oil Type/Level/Qty	10 wt. Fork Oil* / ϕ / 186cc		
Gas Pressure	ϕ		
Spring Length Std.	546.5mm		
Monoshock: Oil Type/Qty	Not Rebuildable		
Gas Pressure	15 kg/cm ²		
Minimum Brake Lining Thickness	Front: 2mm Rear: 2mm		
Tire Size (Nominal Pressure)	F: 2.75-21 (1.7 kg/cm ² / 24 psi) R: 3.50-18 (2.0 kg/cm ² / 28 psi)		
TRANSMISSION - Oil Type/Qty Chg/Qty Reassemble	Yamalube 4* or SAE 10W30 SE / 650cc / 750cc		
Primary Drive Type/Teeth/Ratio	Helical Gear / 71-22 / 3.227		
Secondary Drive Type/Teeth/Chain	Chain / 49-16 / DID428DSM-118L		
Clutch Friction Plate Thickness Std ~ min.	3.0mm ~ 2.8mm		
Clutch Spring Length Std ~ min.	33.0 ~ 32.0mm		
Middle Gear Case Capacity	ϕ		
Final Gear Case Capacity	ϕ		
Gear Case Lubricant: Temp above 5°C (40°F)	ϕ		
Temp below 15°C (60°F)	ϕ		
All Weather Conditions	ϕ		

Service Copy: _____ Service Mgr. _____ Mechanic _____ Mechanic _____ Mechanic _____ Binder _____

Office Copy: _____ General Mgr. _____ Sales _____ Parts _____ Binder _____

©YAMAHA MOTOR CORPORATION, U. S. A., BUENA PARK, CALIFORNIA November 27, 1978 PAGE 1 OF 2

CHARGING SYSTEM	Flywheel Magneto / Single Phase / Half Wave
Battery: Model / Spec. Grav. / Chg. Rate	G.S. 6N6-39-1 (6V6AH) / 1.26 / 0.6A
Maximum Output	7.6V-1.6A @ 8000 rpm
TROUBLESHOOTING	
Field Coil Color Code / Ω	ϕ
Charge Coil Color Code / Ω	Grn-Wht ~ Blk / 0.30 Ω ± 10%
IGNITION SYSTEM	Capacitor Discharge Ignition
Ignition Timing	19.5° BTDC @ 2000 rpm (1.8mm BTDC)
Spark Plug Type	Champion N-3
Spark Plug Gap / Torque / Cap Ω	0.8 ~ 0.8mm / 2.5 m·kg / 5K Ω ± 10%
Point Gap / Condenser Capacitance	ϕ / ϕ
TROUBLESHOOTING	
Ignition Coil Test Gap / Primary Ω / Secondary Ω	6mm / 1.0 Ω ± 10% / 5.9K Ω ± 20%
Pulse Coil or Pick-up Coil Color Code / Ω	Wht-Red ~ Blk / 12.4 Ω ± 10%
Source Coil Color Code / Ω	Lo: Brn ~ Blk / 420 Ω ± 10% Hi: Red ~ Blk / 13.6 Ω ± 10%
LIGHTING SYSTEM	
Headlight / Taillight / Signal Rating	6V35-35W / 6V25-5.3W / 6V17W
TROUBLESHOOTING	
Lighting Coil Color Code / Ω	Yel ~ Blk / 0.18 Ω ± 10%
TORQUE VALUES	
Front Axle Nut	10 x 1.25: 4.0 m·kg
Front Axle Holder Nut	ϕ
Rear Axle Nut	14 x 1.5: 8.5 m·kg
Rear Axle Pinch Bolt	ϕ
Clutch Nut	14 x 1.5: 5.0 m·kg
Drain Plug	12 x 1.5: 2.5 m·kg
Cylinder Head Cover	ϕ
Cylinder Head:	Nut 8 x 1.25: 2.5 m·kg Stud 8 x 1.25: 2.5 m·kg
Engine Mounting Bolts: Front	8 x 1.25: 2.5 m·kg
Rear, Upper	8 x 1.25: 2.5 m·kg
Rear, Lower	10 x 1.25: 4.0 m·kg

ϕ Does Not Apply to This Model

* Available From Yamaha Parts Distributors, Inc.

CHARGING SYSTEM	Flywheel Magneto / Single Phase / Half Wave
Battery: Model / Spec. Grav. / Chg. Rate	G. S. 6N8 3B-1 (6V6AH) / 1.26 / 0.6A
Maximum Output	7.6V-1.8A @ 8000 rpm
TROUBLESHOOTING	
Field Coil Color Code / Ω	ϕ
Charge Coil Color Code / Ω	Grn:Wht ~ Blk / 0.30 Ω \pm 10%
IGNITION SYSTEM	Capacitor Discharge Ignition
Ignition Timing	19.5° BTDC @ 2000 rpm (1.8mm BTDC)
Spark Plug Type	Champion N-3
Spark Plug Gap / Torque / Cap Ω	0.6 ~ 0.8mm / 2.5 m·kg / 5K Ω \pm 10%
Point Gap / Condenser Capacitance	ϕ / ϕ
TROUBLESHOOTING	
Ignition Coil Test Gap / Primary Ω / Secondary Ω	6mm / 1.0 Ω \pm 10% / 5.0K Ω \pm 20%
Pulse Coil or Pick-up Coil Color Code / Ω	Wht:Red ~ Blk / 12.4 Ω \pm 10%
Source Coil Color Code / Ω	Lo: Blk ~ Blk / 420 Ω \pm 10% Hi: Red ~ Blk / 13.6 Ω \pm 10%
LIGHTING SYSTEM	
Headlight / Taillight / Signal Rating	6V35-35W / 6V25-5.3W / 6V17W
TROUBLESHOOTING	
Lighting Coil Color Code / Ω	Yel ~ Blk / 0.18 Ω \pm 10%
TORQUE VALUES	
Front Axle Nut	10 x 1.25: 4.0 m·kg
Front Axle Holder Nut	ϕ
Rear Axle Nut	14 x 1.5: 8.5 m·kg
Rear Axle Pinch Bolt	ϕ
Clutch Nut	14 x 1.5: 5.0 m·kg
Drain Plug	12 x 1.5: 2.5 m·kg
Cylinder Head Cover	ϕ
Cylinder Head:	Nut 8 x 1.25: 2.5 m·kg Stud 8 x 1.25: 2.5 m·kg
Engine Mounting Bolts: Front	8 x 1.25: 2.5 m·kg
Rear, Upper	8 x 1.25: 2.5 m·kg
Rear, Lower	10 x 1.25: 4.0 m·kg

ϕ Does Not Apply to This Model

* Available From Yamaha Parts Distributors, Inc.

www.legends-yamaha-enduros.com

www.legends-yamaha-enduros.com