

# YAMAHA

**MINI  
ENDURO 60 JT2**

[www.legends-yamaha-enduros.com](http://www.legends-yamaha-enduros.com)

## RIDER'S MANUAL

338-28 | 99-11

## FOREWARD

*We are highly gratified that you have selected the YAMAHA MINI ENDURO 60 JT2 a wise choice that promises you many delightful years of motorcycling.*

*Though small in size, this 60 JT2 is a truly attractive motorcycle that Yamaha presents for easy riding. The design is essentially based on the fully-equipped full size enduros, such as tractive Yamaha RT2, DT2, CT2 and AT2.*

*This Owner's Manual has been published to provide you with the fundamentals of the MINI ENDURO 60 JT2 . Carefully reading this manual will help you to keep your machine in top operating condition. We hope that you will find the MINI ENDURO 60 JT2 out-standing wherever you go-across the desert or over the mountains.*





# TABLE OF CONTENTS

- 1. SPECIFICATIONS..... 4
- 2. SERVICE NOTES AND SPECIAL TOMLS ..... 9
- 3. FEATURES ..... 11
- 4. YAMAHA AUTOLUBE..... 12
- 5. CONTROL FUNCTIONS..... 14
- 6. BASIC INSTRUCTIONS..... 18
  - 1. Gasoline and Oil ..... 18
  - 2. Pre-operation Check..... 19
  - 3. Operation..... 21
  - 4. Stopping and Parking..... 26
  - 5. Break-in..... 27
  - 6. Maintenance..... 29
- 7. INSPECTION AND SERVICE..... 30
  - Lubrication and Maintenance Chart ..... 30
  - Inspection and Adjustment..... 33
  - Clutch Cable ..... 34
  - Front Brake Cable ..... 36
  - Rear Brake..... 38
  - Front Wheel..... 39
  - Brake Shoe..... 42
  - Brake Drum ..... 42
  - Rear Wheel..... 43
  - Drive Chain..... 47
  - Replacing the Gear Oil ..... 49
  - Checking the Carburetor..... 50
  - Cleaning the Air Cleaner..... 52
  - Cleaning the Element..... 53
  - Cleaning the Fuel Petcock Filter..... 54
  - Spark plug..... 54

Cleaning the Muffler.....	56
Cleaning the Combustion Chamber and Piston.....	58
Steering.....	59

[www.legends-yamaha-enduros.com](http://www.legends-yamaha-enduros.com)



# 1. SPECIFICATIONS

## Performance & Specifications Model JT2

### Dimensions:

Overall length .....	62.4 in
Overall width.....	27.6 in
Overall height.....	36.6 in
Wheelbase .....	41.3 in
Min. ground clearance .....	6.3 in

### Weight:

Dry .....	123 lbs.
Wet .....	134 lbs.

### Performance:

Maximum speed.....	47 mph
Fuel consumption(on paved level roads) (on paved level roads).....	176 mpg @19 mph
Climbing ability .....	20°
Min. turning radius.....	59.1 in
Braking distance .....	24.6 ft/22 mph

### Engine:

Model.....	JT1
Type .....	2 stroke gasoline
Lubrication system.....	Separate lubrication
Cylinder .....	Single forward inclined
Displacement .....	3.54 cu. in
Borex Stroke .....	1.654 x 1.654 in
Compression ration.....	6.4 : 1
Max. power.....	4.5 HP/7,500 rpm
Max. torque.....	3.62 ft. lb/5,500 rpm
Starting.....	Primary-coupled kick starter system
Ignition method.....	Magneto ignition system

**Carburetor:**

Type .....Y16P  
MJ.....#84  
NJ.....#2.085  
JN.....032-2  
AS.....1 ½

**Air cleaner:** .....Wet foam rubber

**Spark plug:**.....B-7HS or M43

**Chassis:**

Frame .....Tubular-Double loop  
Suspension Front.....Telescopic  
Rear .....Swinging arm

**Transmission:**

Clutch.....Wet multiple-disc  
Primary reduction system.....Gear  
Primary reduction ratio.....3.894(74/19)  
Gear shifting type.....Constant mesh 4 speed  
Gear ratio 1st .....3.077  
2nd.....1.889  
3rd.....1.304  
4th.....1.083  
Secondary reduction system.....Chain  
Secondary reduction ratio.....3.153(41/13)  
Oil capacity .....0.634 U.S qt(600 c.c.)

**Steering:**

Caster.....63.5°  
Trail.....2.7 in

**Tire size:**

Front .....2.50-15-4PR (Trial Universal)  
Rear .....2.50-15-4PR (Trial Universal)

**Tanks:**

Gasoline tank capacity .....1.1 gals.  
Oil tank capacity .....1.1 qts.

**Dynamo model:**.....F11-L40

**Battery:**

Model No.....6N2-2A-3

Capacity.....6V2AH

**Lighting:**

Headlight .....6V15W/15W

Taillight .....6V3W

Stoplight .....6V10W

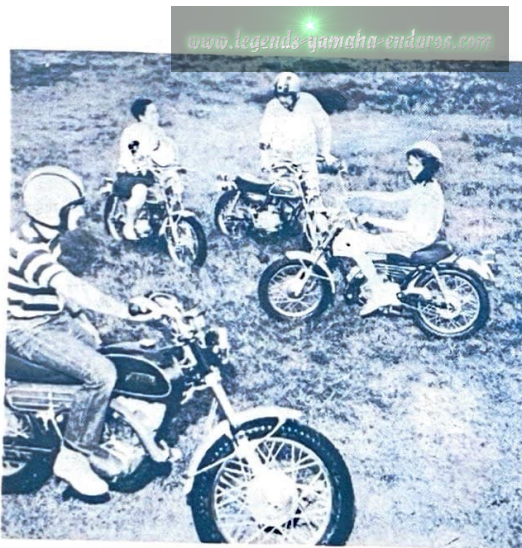



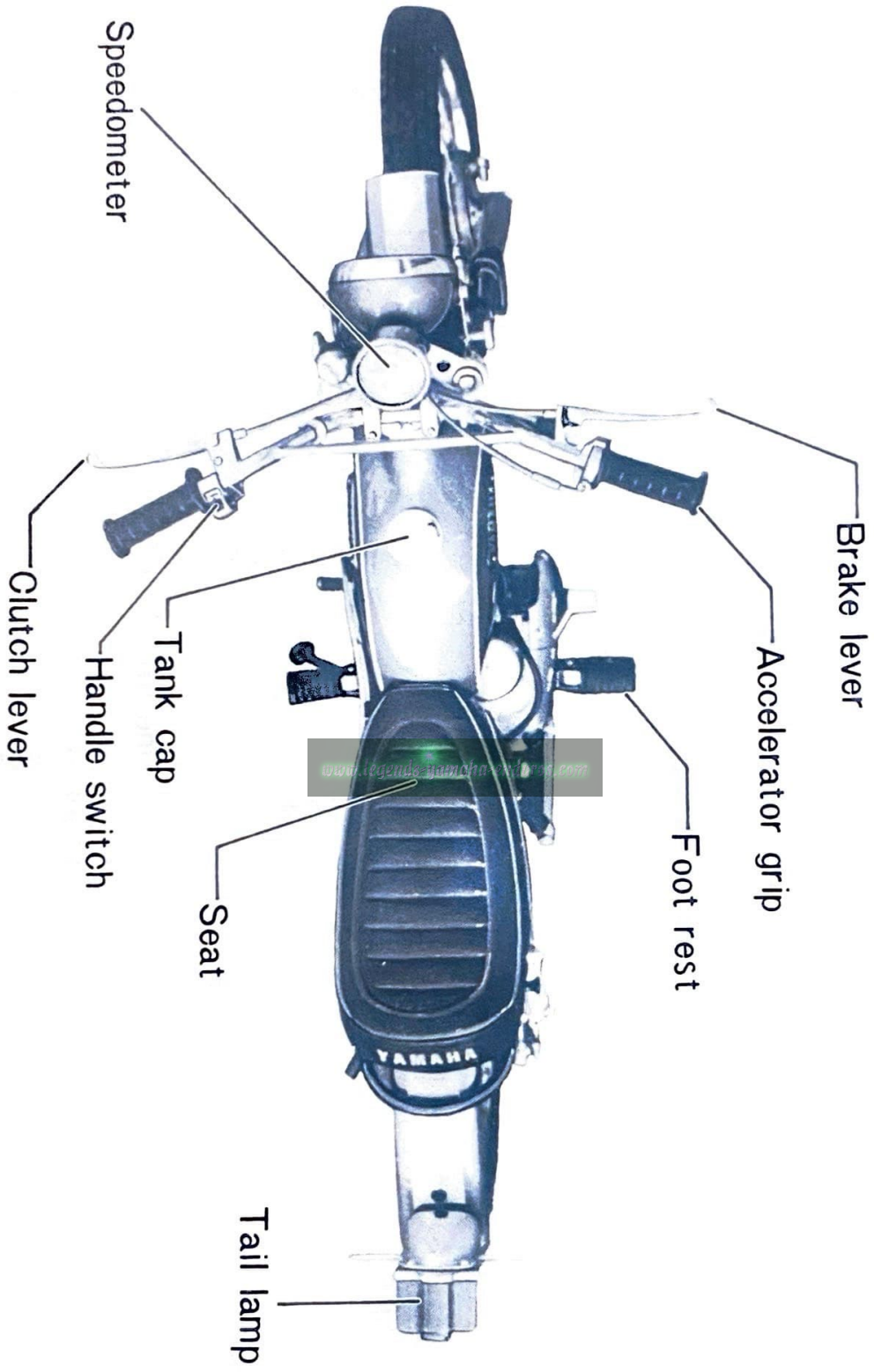

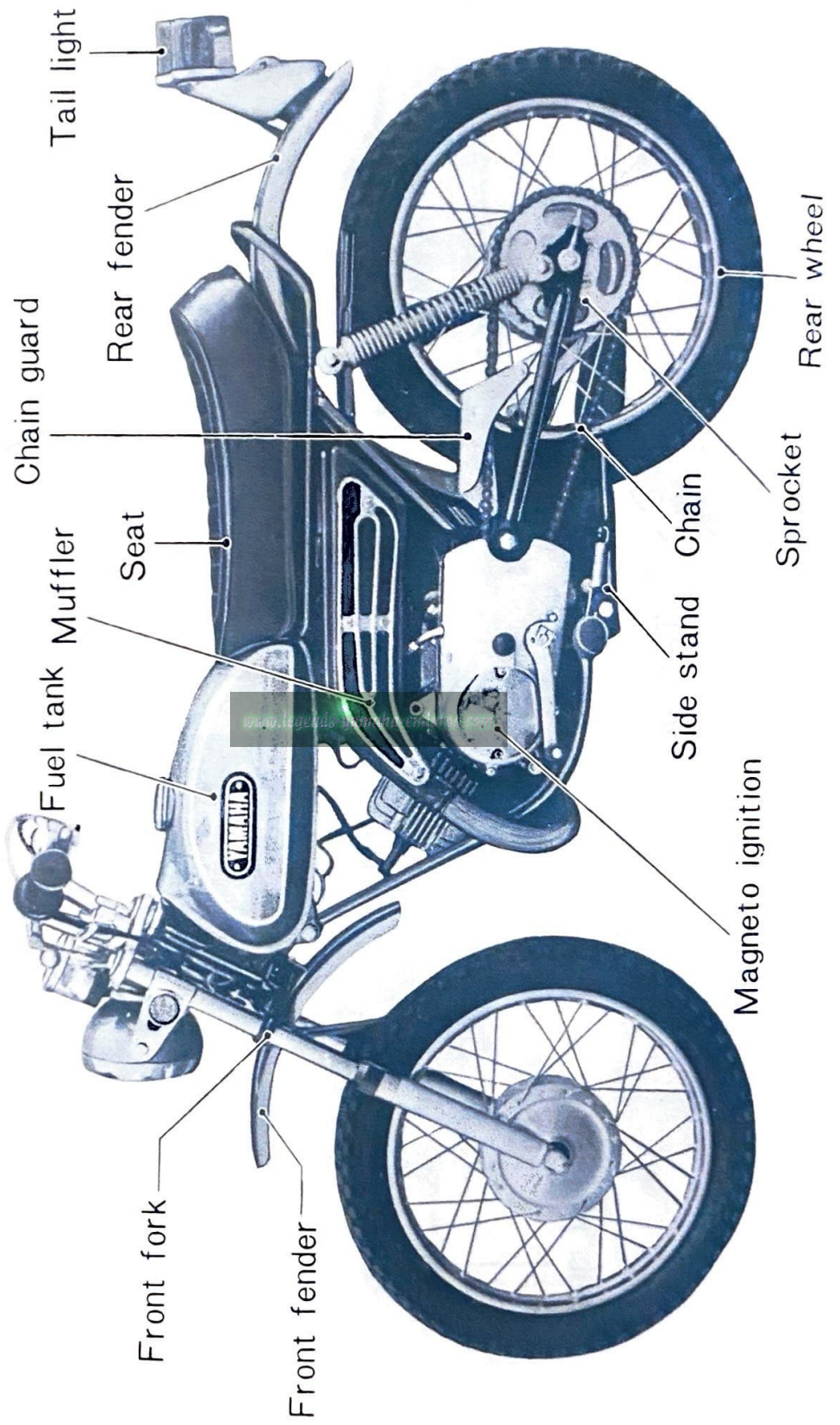

## 2. SERVICE NOTES AND SPECIAL TOOLS

The servicing information included in this manual is intended to provide you, the owner, with the necessary information to provide a means of doing your own preventive maintenance and minor repairs. The tools provided in the owner's tool kit are sufficient for this purpose.

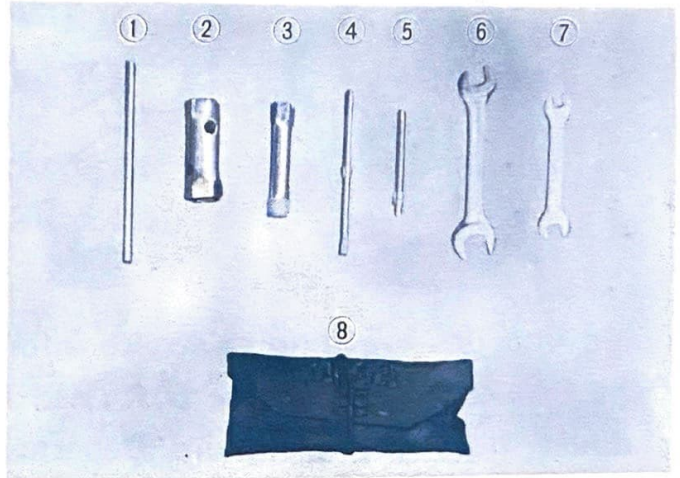

1. Cross bar
2. Box spanner 21 x 23 mm
3. Box handle
4. ⊕ ⊖ driver
5. ⊕ driver
6. Spanner 13 x 17 mm
7. Spanner 8 x 10 mm
8. Tool bag

The JT2 because of its design, sometime, requires professional mechanical care. For this reason some procedures must be performed by an Authorized Yamaha Dealer and are not included in this manual.



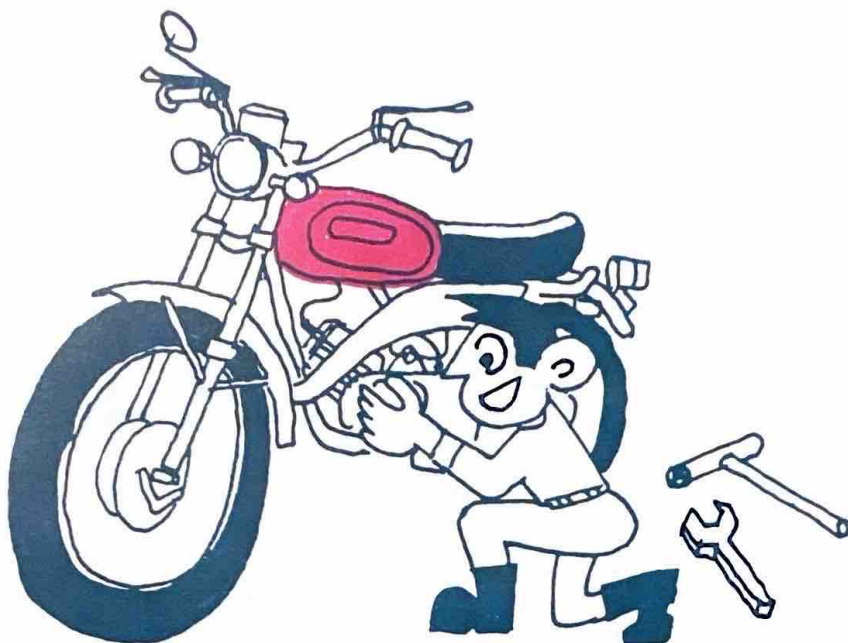

Should you desire additional service information on your JT2 copy of the Service Manual can be purchased from any Authorized Dealer or direct from the Literature Department, Yamaha International Corp., P. O. Box 54540, Los Angeles, Calif. 90054.

(Canadian Distributor : Fred Deeley Ltd., 854 West 6th, Vancouver, B. C., Canada).

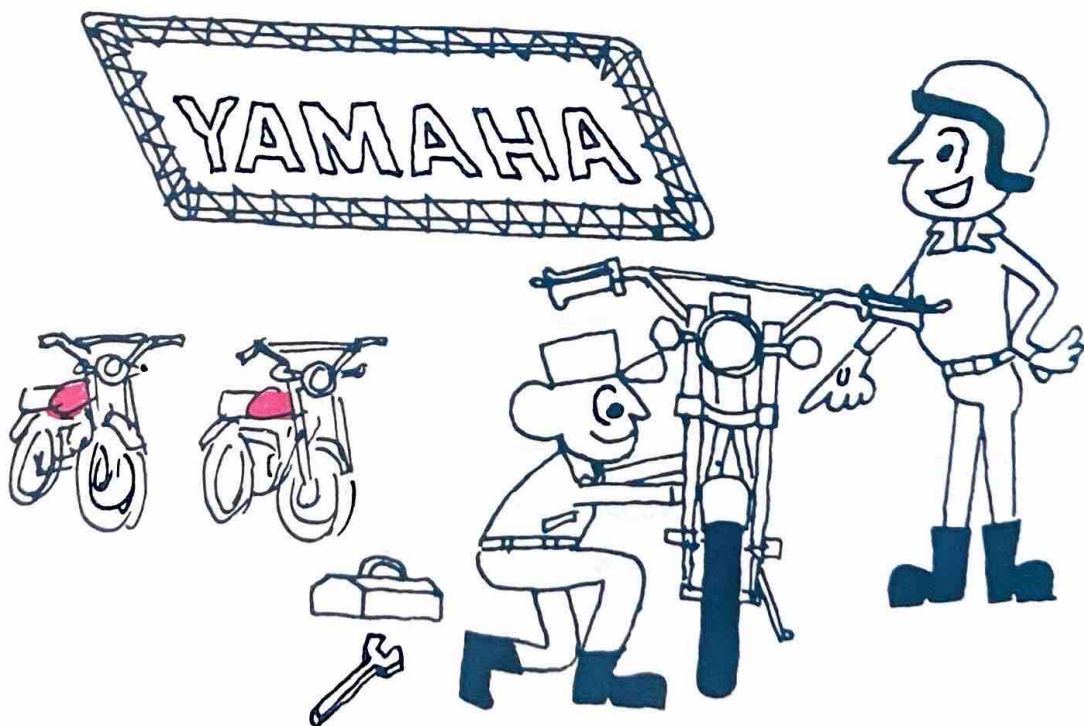

### 3. FEATURES

#### 1. Features

##### 1. Highly-dependable Yamaha Autolube

Yamaha Autolube provides superior engine lubrication that extends the service life of the engine.

##### 2. Efficient Primary Kick Starter

The primary kick starter enable the engine to start both in gear or in neutral.

##### 3. Powerful Brakes

Patented water-proof, dust-proof, brake drums provide safe, fade-free braking on wet or dusty roads.

##### 4. Front Fork Design

The Yamaha Enduro 60 JT2 employs a front fork design well-known for its strength and superior handling characteristics. Its use assures the rider of the ultimate suspension for even the roughest terrain.

##### 5. Tires

The Yamaha JT2 is fitted with Trials Universal tires as standard equipment. This particular tread is one of the most versatile available. It gives maximum trail traction, yet is compatible with road usage.

##### 6. Carburetor Starter Feature

Yamaha's starter feature is already well-known for providing easy starting. Equipped with this unique carburetor, the Yamaha JT2 is quick starting under all conditions.

## 4. YAMAHA AUTOLUBE

### What is Yamaha Autolube?

Yamaha Autolube is an automatic lubrication system which obsoletes the conventional two-stroke pre-mixing system. Oil stored in the oil tank is metered automatically to the engine by an oil pump, with the quantity varying according to engine speed and load.

The heart of the system is the compact, precision-built oil pump. Driven off the engine crankshaft through reduction gears, the varying oil needs are regulated by the pump which feeds the oil directly to the engine. Regulation is controlled through engine rpm's and throttle setting.

### Features:

Yamaha Autolube eliminates the lubrication problems peculiar to two-stroke engines with the conventional "pre-mixing" system. Oil is never contaminated by gasoline prior to delivery to the engine, nor is it subject to denaturing through storage in the gas tank.

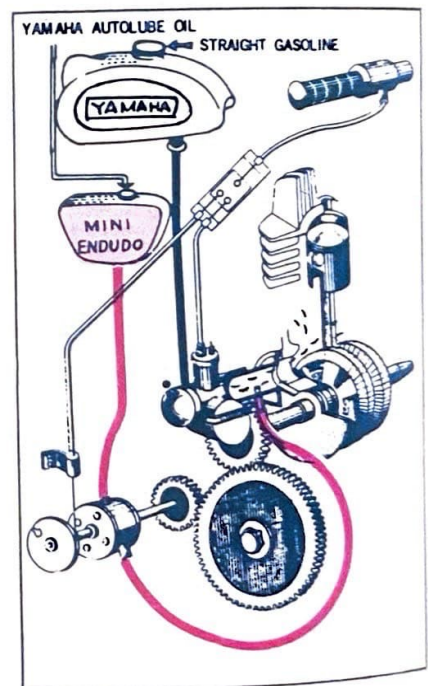

#### 1. The Autolube system results in:

- \* Oil consumption up to 1/3 LESS than that of pre-mix lubrication systems.
- \* Greatly reduced carbon build-up.
- \* Reduced exhaust emission.

#### 2. The Autolube system provides:

- \* Fresh oil supply.
- \* Complete lubrication due to large oil particles.
- \* No worries about the compatibility of oil and oil-fuel mixing ratios.

#### 3. The Autolube system means:

- \* Fuel-"straight" gasoline only.
- \* No pre-mixing of oil and gasoline.



## 5. CONTROL FUNCTIONS

### 1. Main Switch

The main switch has three positions: Off, Day and Night.

The following table shows the electrical connections with the key in each position.

(The circle indicates the "Key" position)

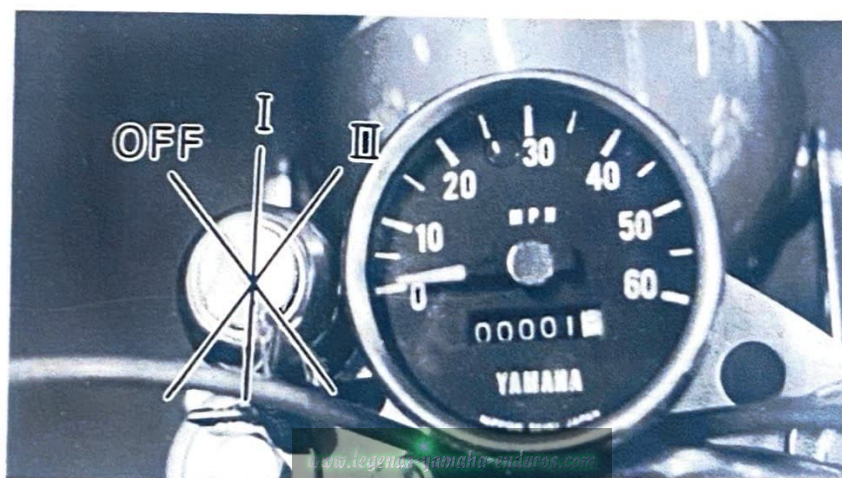

	off	I	II	
Engine		○	○	Kick the kick pedal to start
Meter lamp			○	
Headlight			○	
Taillight			○	
Stoplight		○	○	When the brake is applied.
Horn		○	○	Push the horn button.

## 1. Fuel Petcock

A fuel petcock is located on the bottom of the fuel tank. When the lever is turned downward, it is set to "ON", and fuel begins to flow. If the fuel stops flowing with the lever "ON", turn the lever to "RESERVE". The fuel remaining in the tank will permit the machine to travel a distance of 20 to 25 miles more before the tank becomes empty. When parking or stopping the machine, the fuel petcock lever should be set to "STOP".

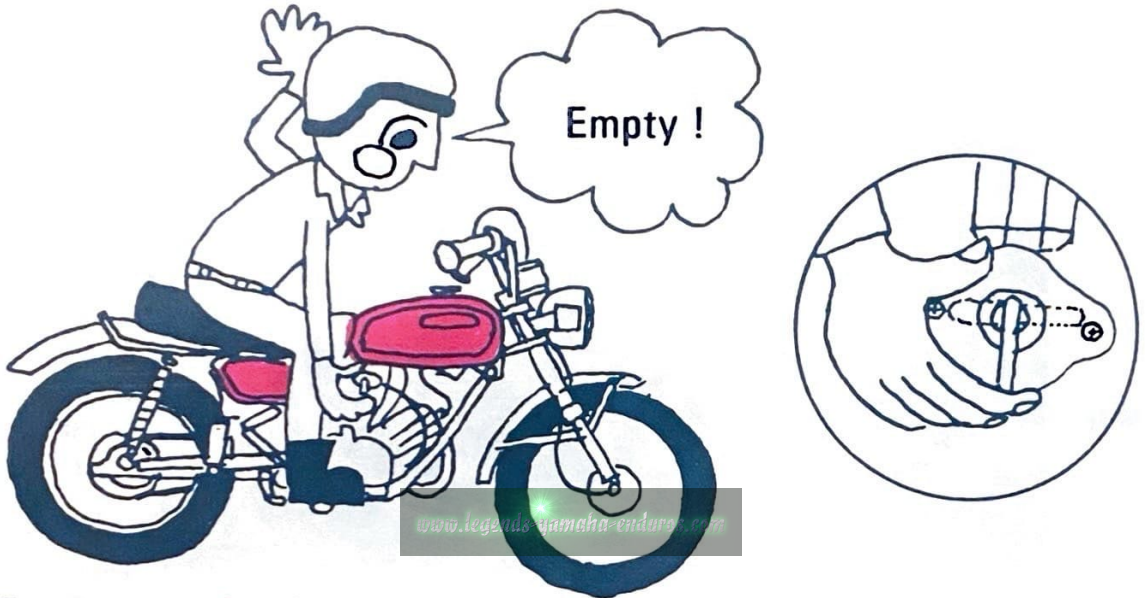

## 2. Starter Jet Lever

The JT2 is equipped with a mixture enriching jet built into the carburetor for cold engine starts. Lift the lever up to actuate this system. Push the lever back down as soon as the engine has started and will continue to idle without the rich mixture.

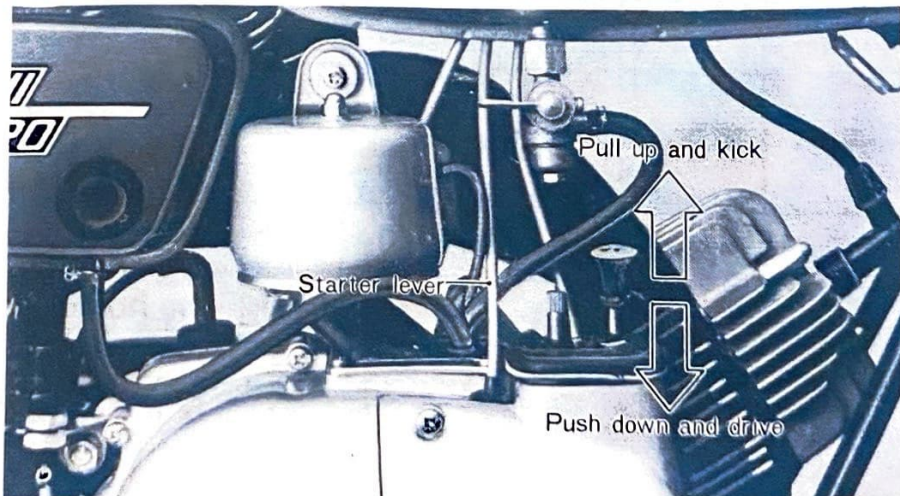



#### 4. Handle Lever Switch

- a) To lower the headlight beam, push the switch toward you.  
To raise the beam, push the switch forward.
- b) To sound the horn, depress the horn button.

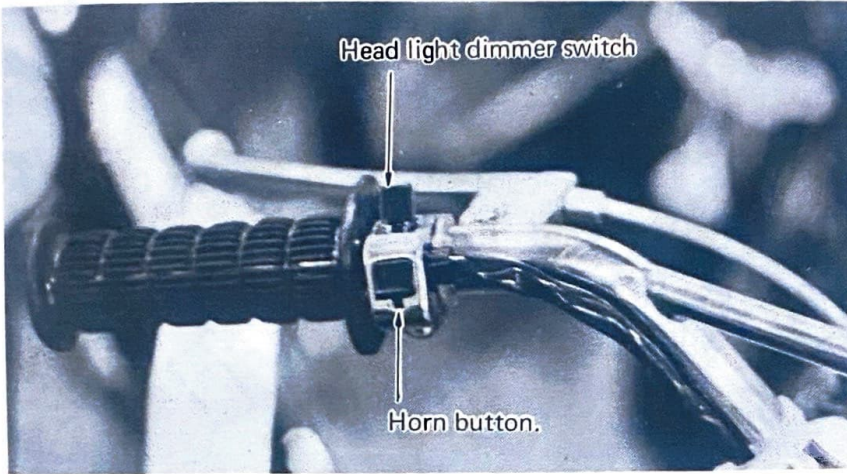

- c) To stop the engine, push the engine stop button.

[www.legends-yamaha-enduros.com](http://www.legends-yamaha-enduros.com)

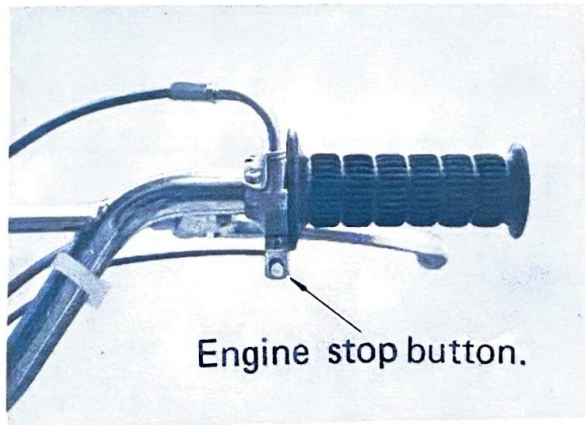



## 5. Clutch(Left handle lever)

The left handle lever controls the operation of the clutch. The clutch itself is of the wet, multiplate type and is mounted within the right-hand crankcase cover. It is adjustable at two points, one of which is on the lever. Adjustment will be explained later.

## 6. Front Brake

The right handle lever controls the operation of the front brake. The front brake is of the single leading shoe variety and is adjustable at two points, one of which is on the lever. Adjustment will be explained later.

## 7. Rear Brake

Located on the right-hand side of the machine next to the footpeg, the rear brake pedal actuates the single leading shoe rear brake.

[www.legends-yamaha-enduros.com](http://www.legends-yamaha-enduros.com)

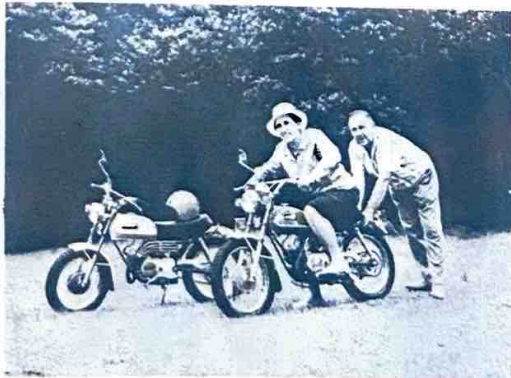

## 8. Shift Lever

On the left-hand side of the engine, just forward of the footpeg is the shift lever. With a slight pressure from the left foot the lever can be moved to select neutral or any one of the four gear ratios within the transmission.

To select neutral, ratchet the pedal upward until low gear is engaged and then raise it slightly. The transmission selector mechanism is of the ratcheting type and a firm movement of the foot will automatically select the next lower or higher ratio.

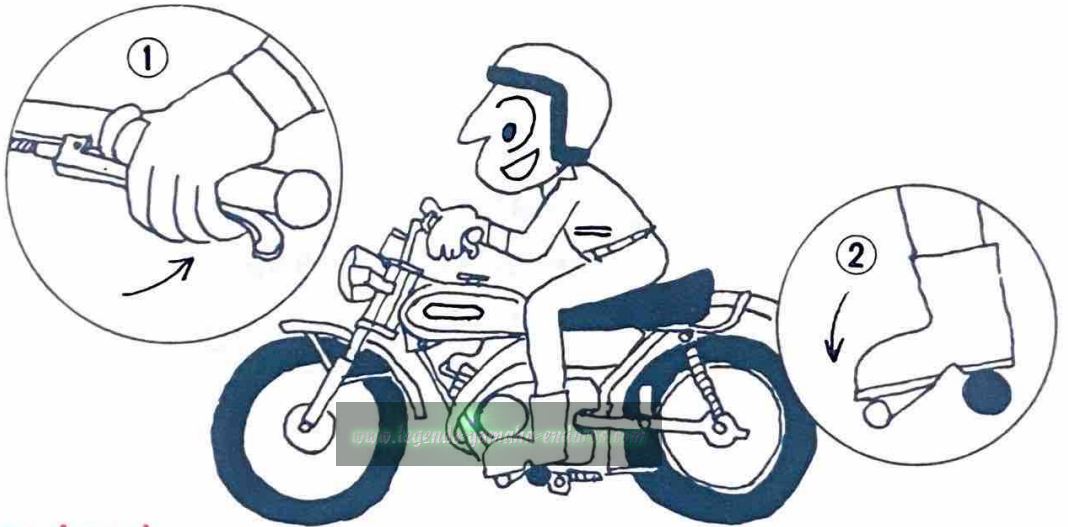

## 9. Seat Latch

Located under the right-hand edge of the seat is the release latch. Pull out on the spring loaded latch, raise the seat, and pull back.



## 6. BASIC INSTRUCTIONS

### 1. Gasoline and Oil

#### Gasoline:

Use fuel with an octane rating of 90 + Some regular fuels and most mid-range have 90 + octane ratings. Ethyl grade fuels usually have octane rating in excess of 100. In addition, they have considerable tetra-ethyl lead added which can cause spark plug problems.

Whenever possible use fresh, name-brand, regular gasoline of 90–100 octane rating.

#### Oil:

We recommend that your first choice be YAMALUBE, which can be purchased from any Yamaha Dealer. If for any reason you use another type of oil, choose from the following list, which is in descending order of preference.

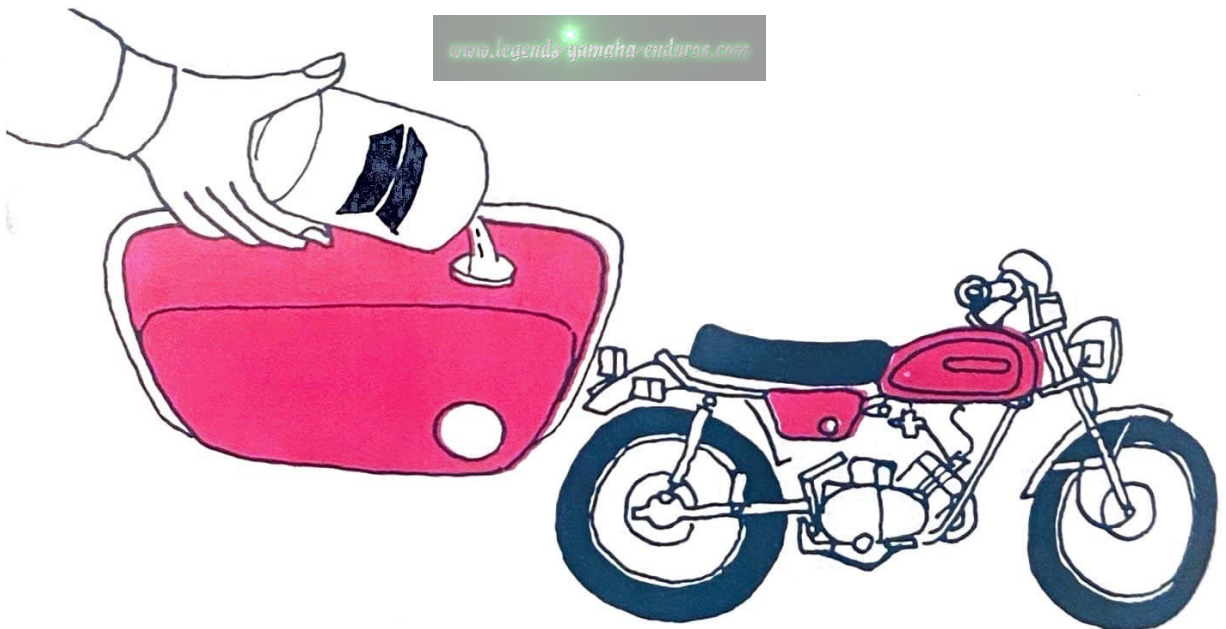



- 1) Another brand of 30 wt. two-stroke oil designed for air cooled engines.
- 2) A 30 wt. two-stroke oil designed for water cooled engines.
- 3) A 30 wt. two-stroke "all purpose" oil.
- 4) A 30 wt. detergent type, automotive oil.

## 2. Pre-operation Check

You should check the following points before each usage.

### 1. Is there sufficient fuel?

Make sure that there is sufficient fuel for your driving plan. Fill the fuel tank with gasoline only.

### 2. Is there sufficient oil?

If the oil is below the center hole on the glass view port, refill the oil tank with Yamaha Autolube Oil (YAMALUBE).



### 3. Is the tire pressure correct?

The wrong tire pressure affects the riding comfort, steering and life of tires.

Correct tire pressure:

Front-22.4 lbs/in<sup>2</sup> . (1.6 kg/cm<sup>2</sup>)

Rear- 28.0 lbs/in<sup>2</sup> . (2.0 kg/cm<sup>2</sup>)

4. **Do the front and rear brakes work effectively?**

Try the brake lever(right handlebar) and the foot brake(on the right side of the engine)

5. **Do the lights function well?**

Check the headlight, stoplight etc.

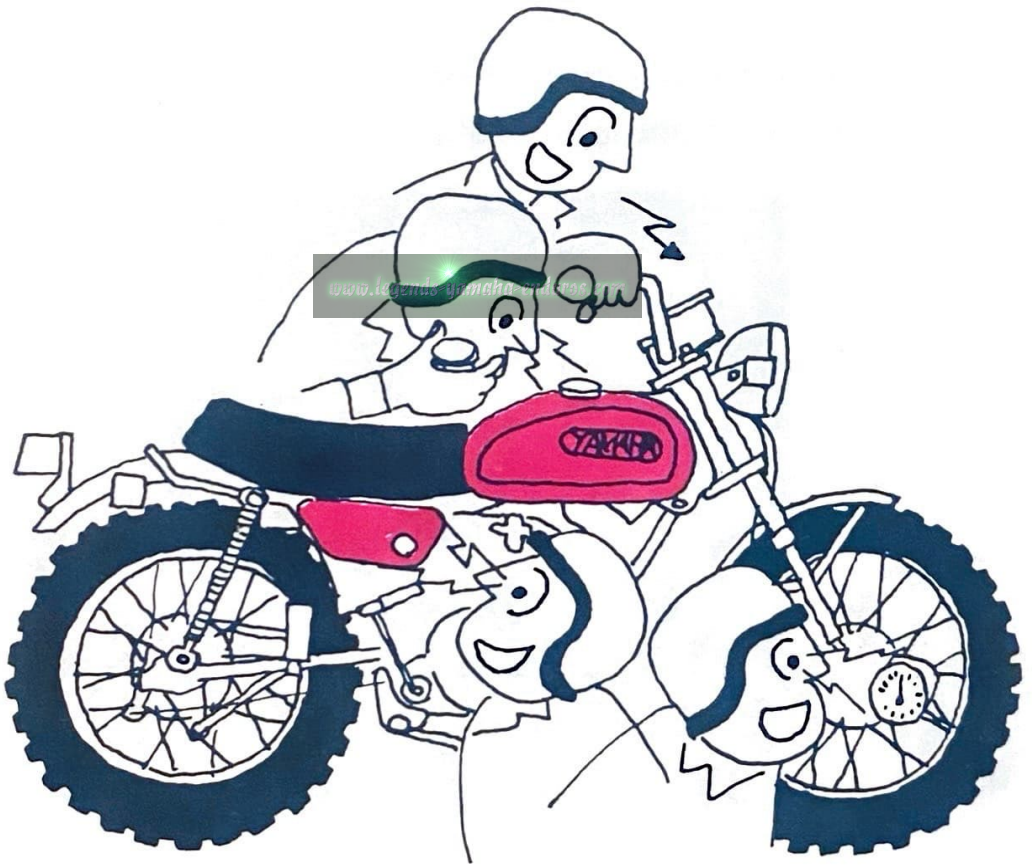

### 3. Operation

#### 1. Starting the Engine

The Yamaha MINI Enduro 60 JT2 employs the kick starter system. The carburetor is provided with a starting system to produce the rich air-fuel mixture required for easy starting of the engine. It assures quick starting even in extremely cold weather.

#### Preparation for Starting

- \* Turn the fuel cock lever to the "ON" position.
- \* Insert the ignition key and turn it to "1".
- \* The engine can be started by kicking the kick pedal when the transmission is in neutral or by disengaging the clutch first if the transmission is in gear.

#### Starting when the engine is cold

Most engines are more difficult to start in cold weather. For easiest starting, a richer mixture of gas/air can be obtained by operating the starter lever.

- \* Pull the starter lever up.
- \* Start the engine by kicking the kick pedal with the accelerator grip closed.

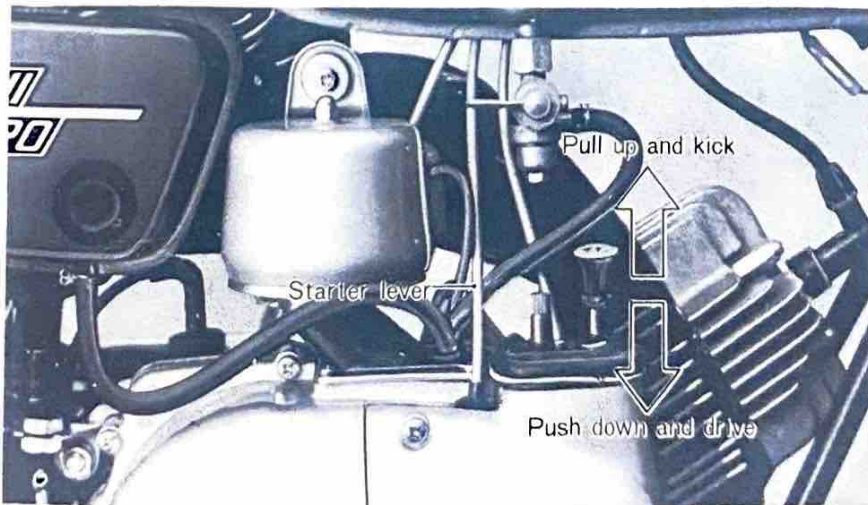



## Starting when the engine is warm

When the engine is still warm from running or in warm weather:

- \* Don't use the starter lever.
- \* Slightly open the accelerator grip, and kick the kick pedal.

## Warming Up

It is very important to allow a warming-up period of 2 minutes or so after starting the engine. After the engine has started, the lifted starter lever must be released. Keep the accelerator grip open until the engine begins to run smoothly.

Correct engine warm-up, along with periodic inspections, will assure a longer performance life from your engine.

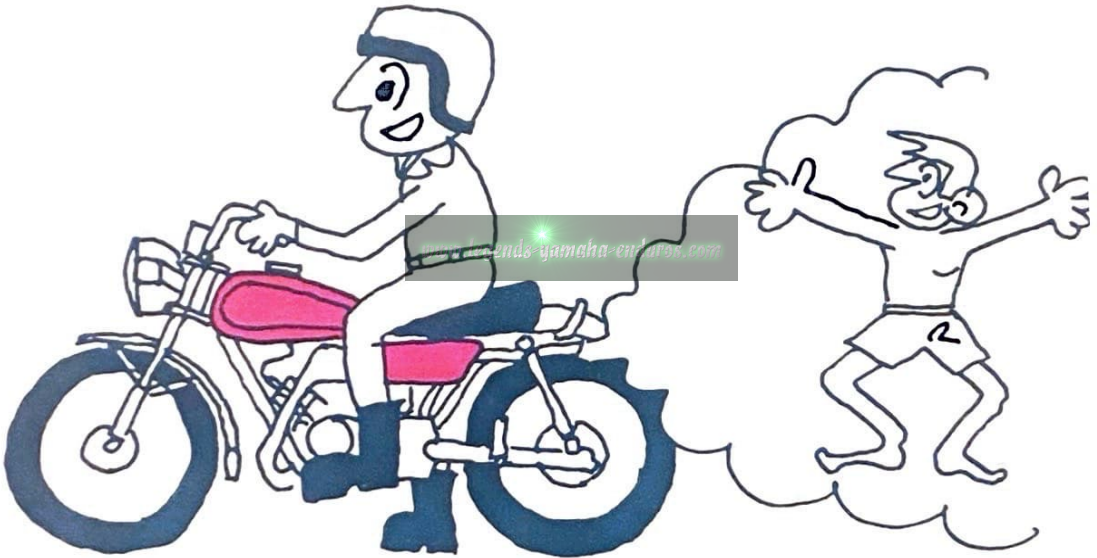

## 2. Operation Procedure

### Shifting Gears:

The Yamaha 60 JT2 is equipped with a foot-operated, 4-speed transmission.

Shifting gears allows you to control the machine according to engine, speed and road conditions.

This Yamaha 60 JT2 has a 4-speed transmission with a rocker-type gear-shift pedal.

“Neutral” is positioned where the pedal is lifted to the end of its travel.

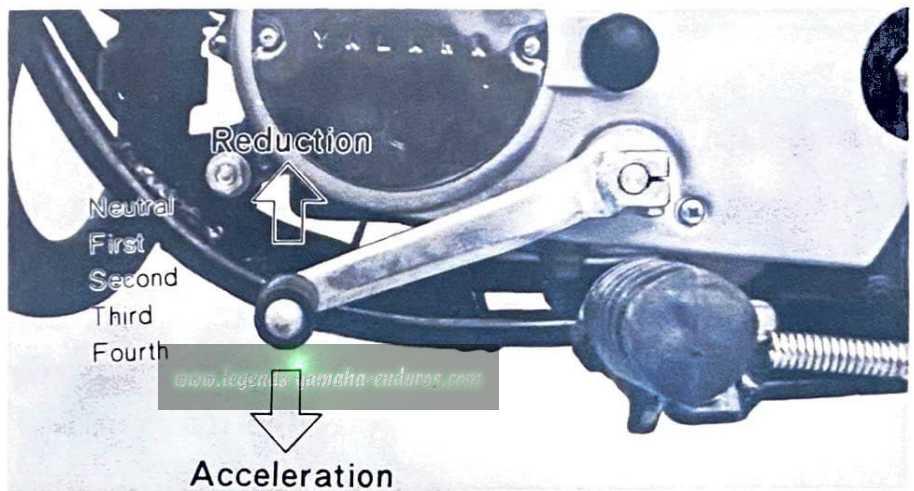

### Starting

Pull in the clutch lever with your left hand.

Push the gear-shift pedal down to first gear with your toe. Twist the throttle slightly to raise the engine speed and slowly release the clutch lever. Then your bike will start smoothly.

## General driving:

When the machine speed rises to 10 mph(15km/1h) after.

- \* Turn off the throttle slowly and pull in the clutch.
- \* Push the gear-shift pedal down to second gear with your toe.
- \* While releasing the clutch lever, turn on the throttle to accelerate.
- \* When the machine accelerates to 20 mph(30 km/h), push the gear-shift pedal down to third gear.
- \* When reducing speed, close the throttle and pull in the clutch lever. Lift the gear-shift pedal into the next lower gear position and release the clutch lever.

While applying the "engine brake", gently use the brakes and shift down in sequence.

## Going Uphill:

- \* When starting to climb a gentle grade, open the throttle little by little to avoid losing engine speed and power.
- \* If the grade is steep and speed seems to decrease, shift down from Fourth to Third, and from Third to Second as required.
- \* If you fail to shift down timely, the machine will lose engine speed and power on the slope and you will have to shift down further.

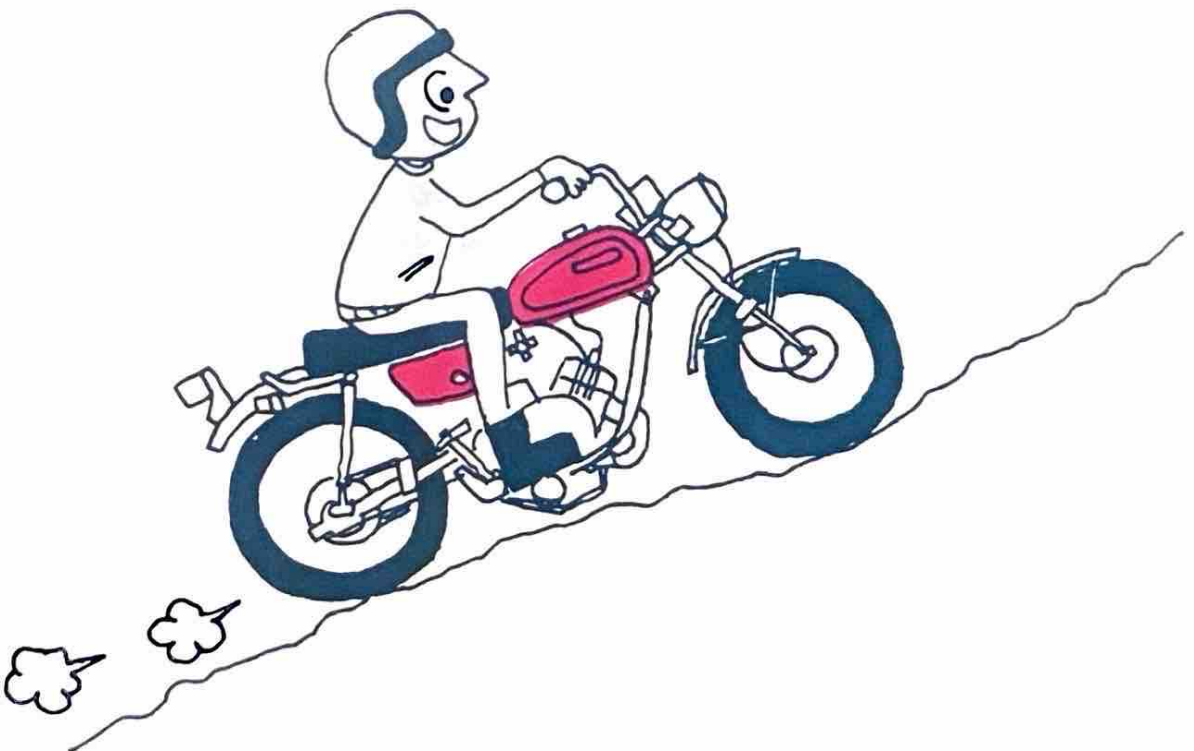



## Going Downhill:

- \* On a long down grade or sharp descent, don't rely on the brakes alone, but use the "engine brake." (The "engine brake" can be applied by reducing engine speed. Close the throttle with gears and clutch engaged. Because the engine rpm is slow the engine, in turn, is driven by the rear wheel, thus resisting the rotation of the rear wheel. This serves as a brake.)
- \* The lower the gear selection the more effective the engine brake. If the slope is gentle, shift down to Fourth or Third. If steep, the transmission should be in Second.
- \* Generally speaking, it is advisable that the transmission be in the same position that you would otherwise shift in when climbing the slope.

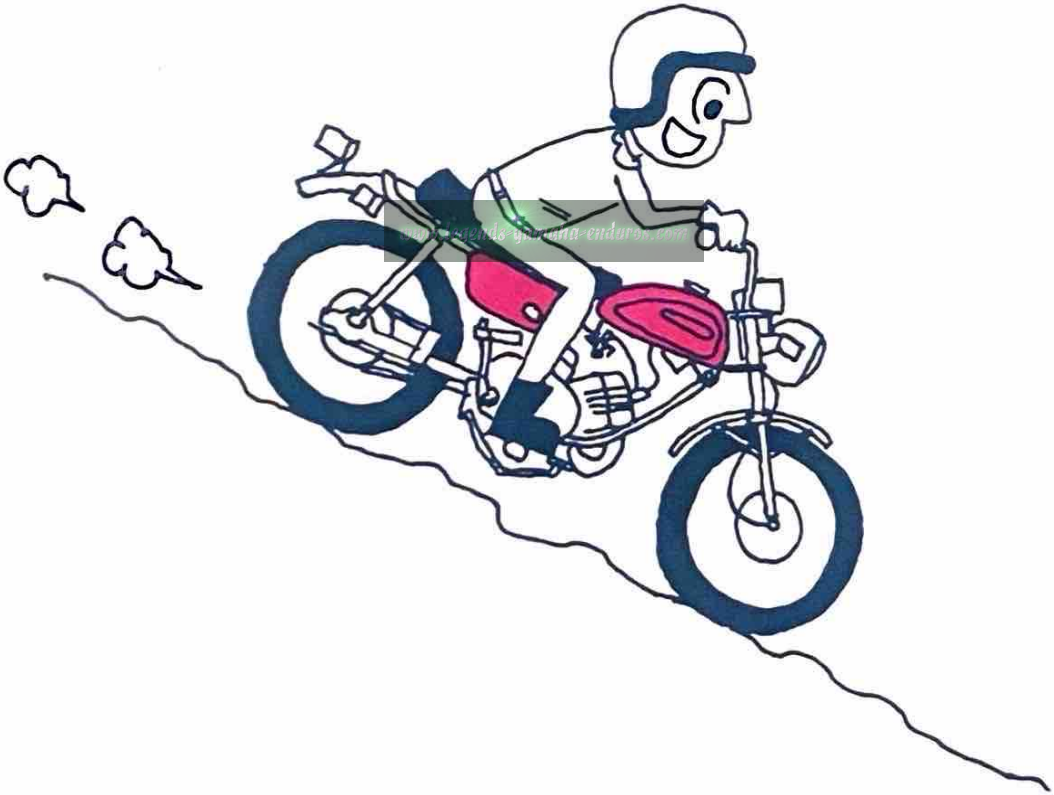

**Note:** When shifting gears, keep from over-revving and possibly damaging the engine. Keep the rpm's in the 3,000–7,000 rpm range except during break-in, which will be explained later.

#### 4. Stopping and Parking

\* Slowly reduce the speed by shifting down in sequence, and apply both front and rear brakes together.

Just before stopping your bike, it is necessary to shift into Neutral.

\* When stopping the bike at high speed, be sure to apply both brakes. Applying the front brake alones may cause the bike to turn over or skids.

\* While parking the bike, keep the fuel petcock at "Stop".

\* When using the side stand, be sure that the ground is not soft; otherwise, the bike will fall down.

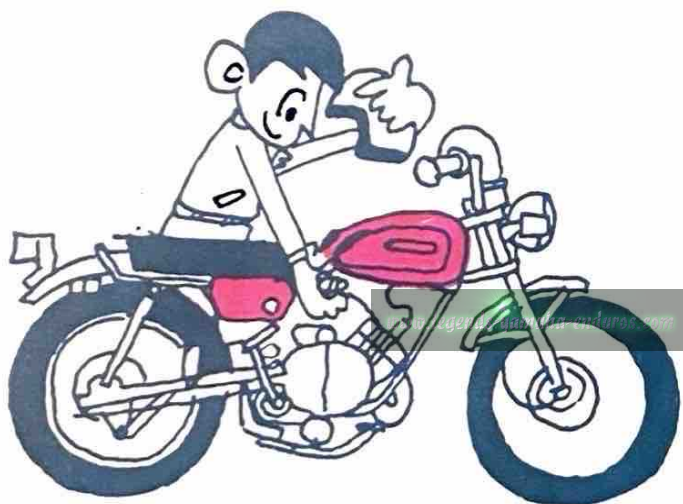

Stop position

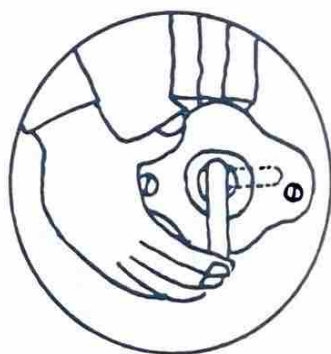

If you are a new rider, find someplace to practice. If you are an experienced rider, but unfamiliar with this model.....Find someplace to practice. If necessary, enroll in a driver education course.

## 5. Break-in

There is never a more important period in the life of your JT2 than the period between zero and 500 miles.

For this reason we ask that you carefully read the following material.

Because the engine is brand new, you must not put an excessive load on it during the first several hours of running. You could look at it in this matter: During the first 500 miles the various parts in the engine wear and polish themselves to the correct operating clearances. During this period prolonged full throttle operation, or any condition which might result in excessive head and cylinder temperatures, must be avoided. However, momentary full throttle operation under load (5 seconds maximum) does not warm the engine. Each full throttle acceleration sequence should be followed with a substantial "rest period" for the engine by cruising at lower rpm's so the engine can rid itself of the temporary build up of heat.

The method for breaking in a JT2 is quite simple.

1. **Zero to 300 miles:** Avoid continuous operation above half-throttle. Allow a cooling off period of five to ten minutes after every hour of operation. Vary the speed of the motorcycle from time to time. Do not operate it at one set, throttle position.
2. **300 to 600 miles:** Avoid prolonged operation above  $\frac{3}{4}$  throttle. Allow the motorcycle to revolve freely through the gears but do not use full throttle at any time.



3. **600 miles and beyond:** Avoid prolonged full throttle operation. Vary speeds occasionally.

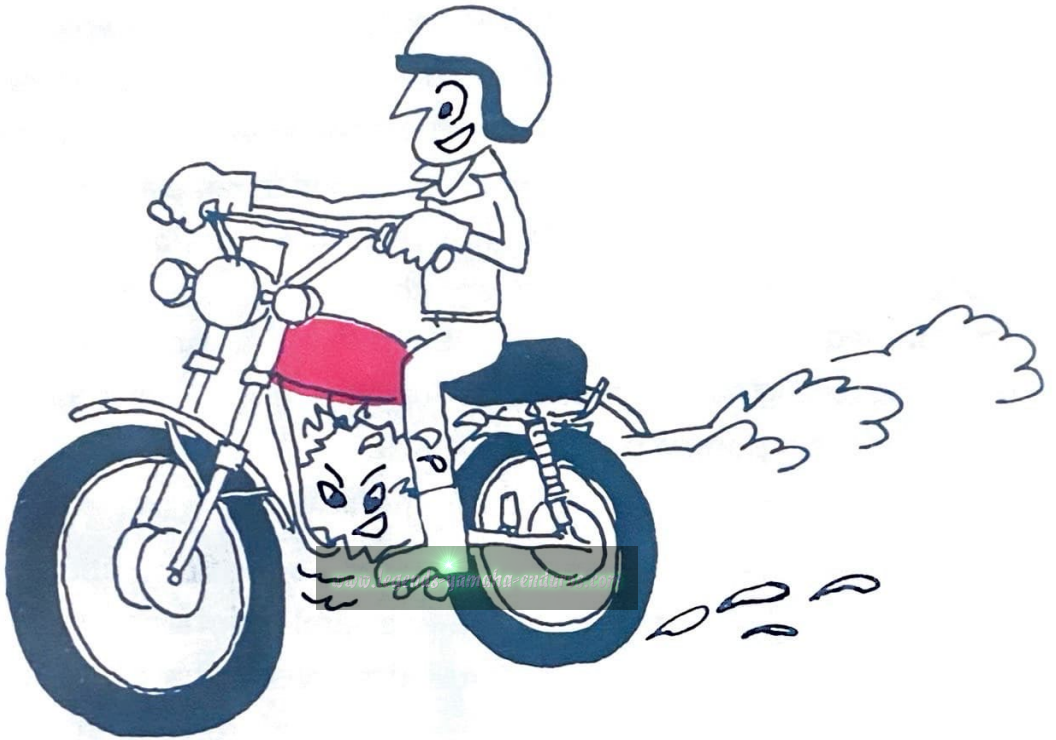

## 6. Maintenance (Trips)

Prior to starting out on a major trip, or at minimum intervals of one month or 1,000 miles, all of the fittings on the motorcycle should be checked for tightness. These include:

1. Chain adjust bolt lock nuts.
2. Front fork and front axle nuts.
3. Carburetor clamp screw.
4. Air cleaner securing screws.
5. Engine mounting bolts.
6. Foot peg and exhaust system securing bolts.
7. Crankcase cover screws.
8. Rear axle securing nut.
9. Front and rear fender mounting bolts. .

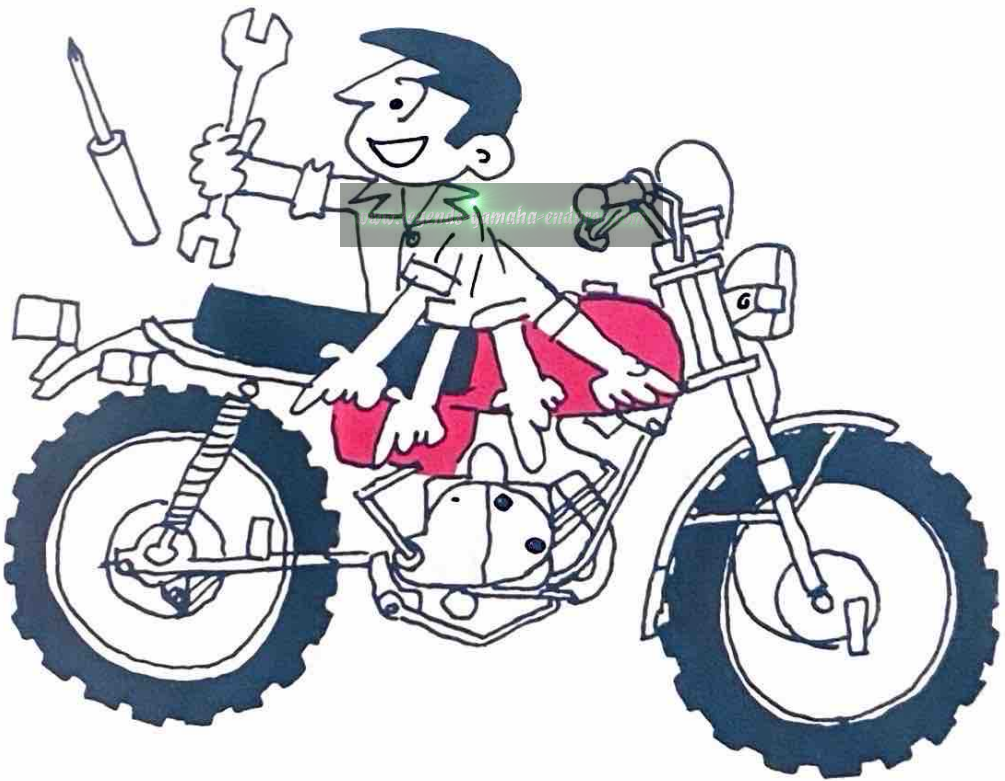

**TORQUE:** All fittings require a minimal amount of torque during tightening to keep them from vibrating loose. Excessive tightening will only lead to stripped threads and broken studs. As a rule of thumb, use the following tightening chart.

STUD SIZE	TORQUE
6 mm	90 in/lbs.
7 mm	135 in/lbs.
8 mm	180 in/lbs.
10 mm	300-350 in/lbs.
12 mm	350-400 in/lbs.
14 mm	400-450 in/lbs.
Axle Nuts	500-600 in/lbs.

## 7. INSPECTION AND SERVICE

### 1. Lubrication and maintenance chart

This chart should be considered strictly as a guide to general lubrication and maintenance periods. You must take into consideration that weather, terrain, geographical locations, and a variety of individual uses all tend to demand that each owner alter this time schedule to match his environment. If the motorcycle is continually operated in an area of high humidity, then all parts must be lubricated much more frequently than shown on the chart to avoid the ravages of water on metal parts. If you are in doubt as to how closely you can follow these time recommendations, check with the dealer in your area.

	Page	Frequency
Clutch cable lubrication:	33	500–1,000 miles. More often in damp or dusty climate.
Clutch cable adjustment:	34	As often as necessary to maintain correct free play.
Speedometer cable lubrication:	37	500–1,000 miles. More often in damp or dusty climate.
Front brake cable lubrication:	36	500–1,000 miles. More often in damp or dusty climate.



Front brake cable adjustment:	37	As often as necessary to maintain correct free play.
Throttle cable and grip lubrication:	13	500–1,000 miles. More often in damp or dusty climate.
Throttle cable adjustment:	13	As often as necessary to maintain 1/32" free play.
Clutch adjustment:	34	2,000 miles. Make adjustment right at the clutch.
Rear brake adjustment:	38	As often as necessary to maintain correct adjustment
Drive chain lubrication:	47	Every 200 miles.
Drive chain cleaning	47	Every other chain lubrication period.
Drive chain replacement:	47	Whenever checks show excessive wear. Check both sprockets for excessive wear at the same time.
Carburetor cleaning:	50	Have dealer disassemble and clean every 3,000 miles.
Cleaner:	52	Clean and oil at least once a month.

Fuel petcock:	54	3,000–5,000 miles. Clean the screen Filter.
Ignition timing:		Have dealer check every 2,000 miles.
Conduct breaker points:	27	Clean points and lubricate point cam every 1,500–2,000 miles. Normal replacement is 8,000–10,000 miles.
Spark plug:	54	Clean and gap every 500–1,000 miles.
Steering:	59	Have dealer grease steering head bearings every 3,000 miles.
Front fork:	59	Change oil every 2,000–3,000 miles.
Nuts and bolts tightness:	29	Once a week and before any trips.
Brake actuating cam lubrication:	36-37	1,500–2,000 miles.
Transmission oil	18	Check weekly; change every 2,000–3,000 miles.

**Note:** The above chart does not include the Warranty Service Check that is performed by your dealer. This check must be performed at the specified mileage as stated in your Warranty Registration. As explained in “Break-In,” the most critical period in the life of your JT2 is during the first few hundred miles; see that it is checked on time and thoroughly.

## 2. Inspection and Adjustments

The methods of inspection and adjustment are discussed below. This information will be of value in your daily inspections.

### Clutch cable maintenance

The clutch cable required periodic lubrication to prevent the cable strands from rusting or hanging up in the casing. First, disconnect the cable from the clutch lever by screwing the adjuster all the way back to the cable casing. This will provide enough free play in the cable for you to slip the cable out of the lever holder through the slot in the lock nut, adjuster, and holder. Hold the cable upright and allow several drops of liquid graphite to flow down the cable. Hold the cable upright for several minutes to permit complete lubrication.

If the cable needs to be replaced, then perform the steps above and disconnect the cable at the lever. Next, disconnect the cable at the engine. Begin by taking off the cover that houses the clutch activating mechanism(left side of the engine).

Looking at the inside of this cover, you will see the clutch actuating arm. Push the arm up and lift the cable end off. Removing the old cable and hooking up the new one will take but a few moments.

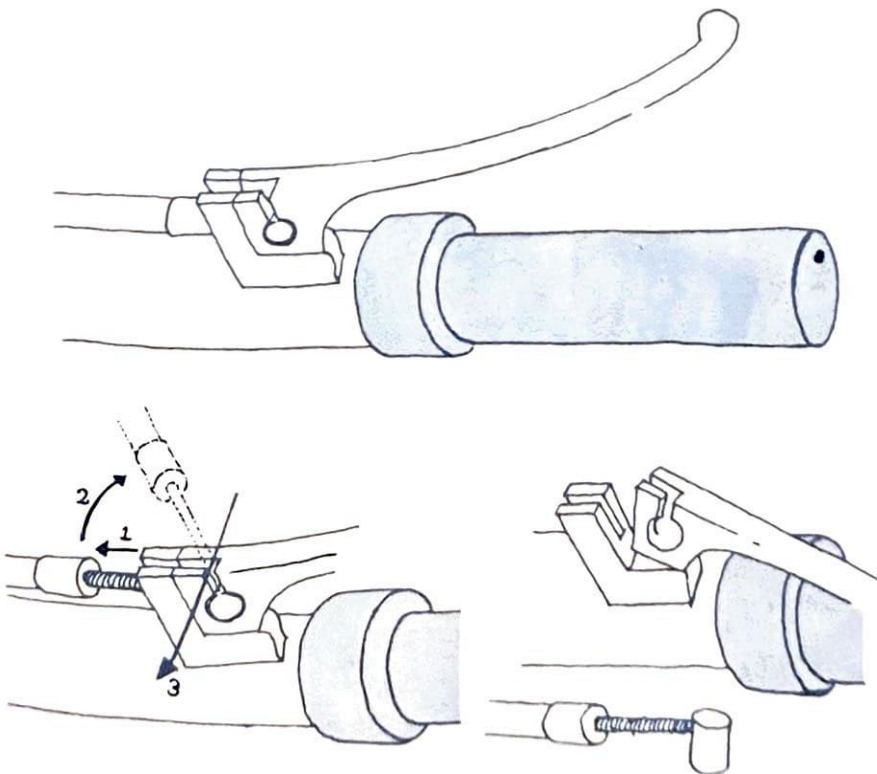



## Clutch cable adjustment:

The clutch lever should have .080 to .120 in (2 to 3mm) free play to maintain full pressure against the clutch facing. If the play is excessive, the clutch will not disengage. If the free play is insufficient, the clutch will slip.

1. First, loosen the lock nut above the left crankcase-cover. Then turn the adjuster either in nor out depending on which direction is necessary to arrive at 2-3mm(1/6''-1/8'' free play).

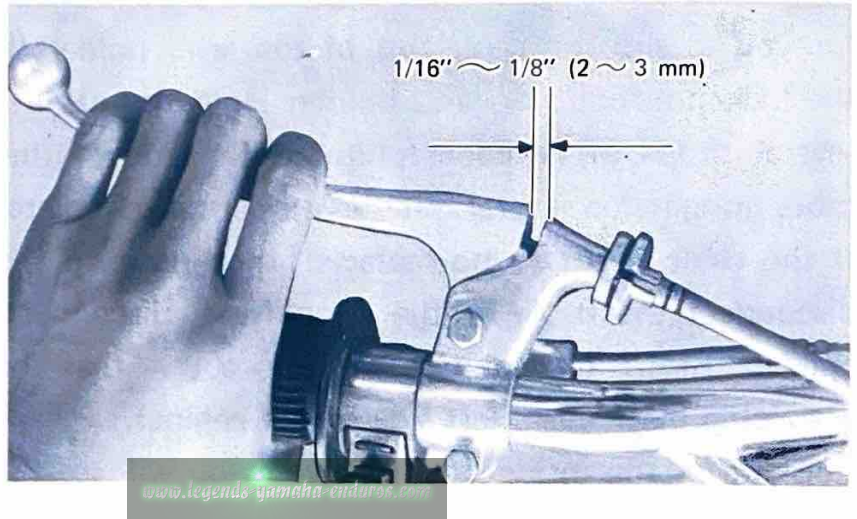

2. The second adjustment is located behind the clutch adjuster cover. Removing the cover will expose the adjusting set screw and lock nut. Loosen the lock nut, rotate the set screw in until it lightly seats against a clutch push rod that works with the set screw to operate the clutch. Back the set screw out  $\frac{1}{4}$  turn and tighten the lock nut. This adjustment must be checked because heat and clutch wear will affect this free play, possibly enough to cause incomplete clutch operation.

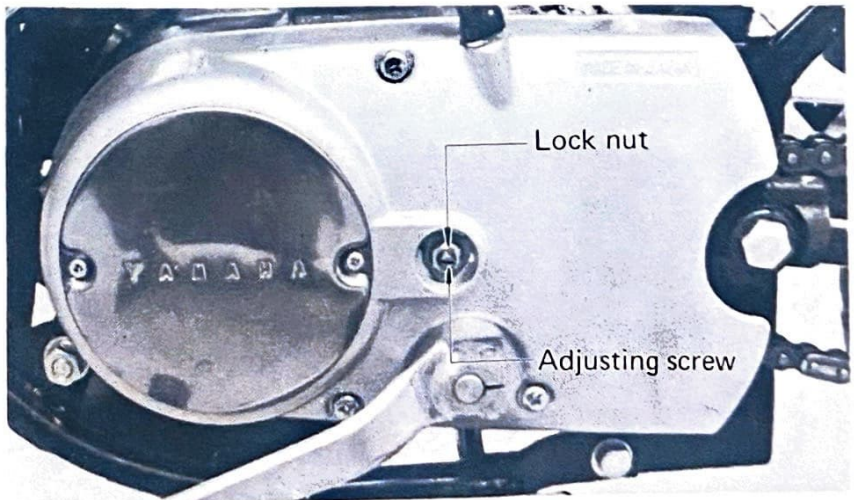
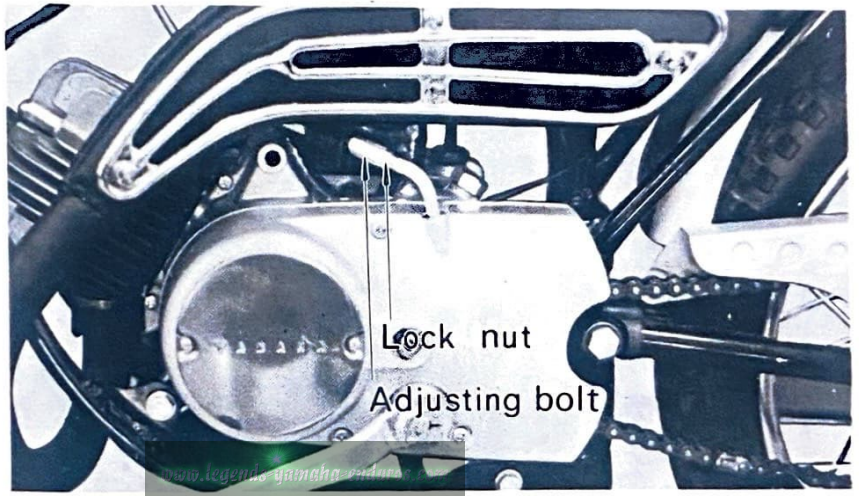

## Front brake cable maintenance:

This cable also needs periodic lubrication. To release one end of the cable for lubrication, follow the same procedures as listed previously in the CLUTCH CABLE MAINTENANCE section.

Removal of the front brake cable requires that you must first disconnect the cable at the lever, as was just explained. To disconnect it at the front hub, you have to screw the cable adjuster in so that there is plenty of cable slack right at the brake. Line up the slots in the adjuster, lock nut, and hub housing, and slip the cable out of the adjuster and out through the slots.

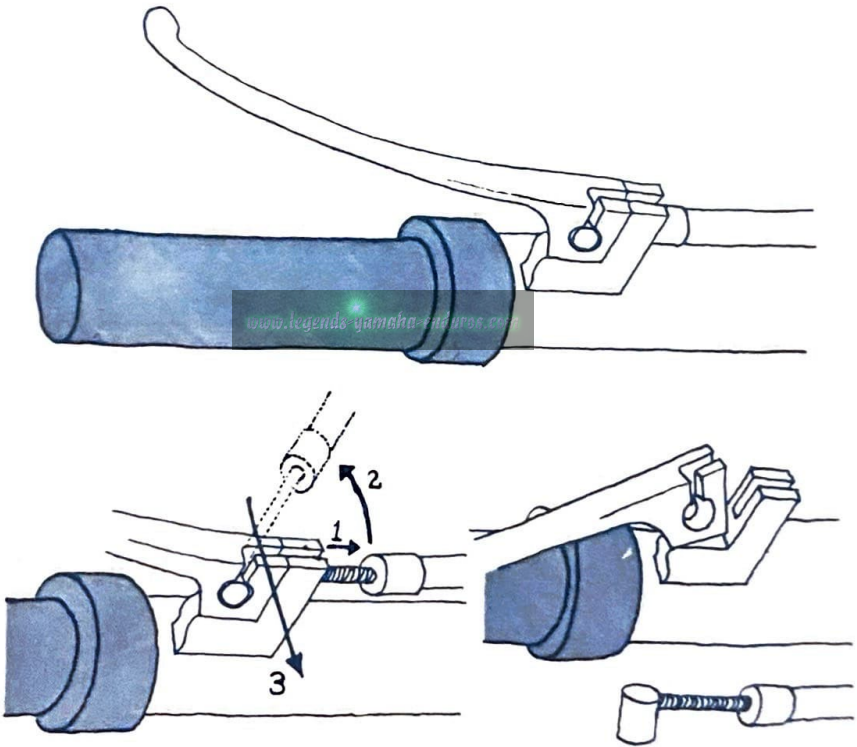



## Front brake adjustment:

Front brake play should be 0.2 to 0.3 in (5 to 8mm). To adjust the play, loosen the lock nut on the front brake cable end and turn the adjust bolt in and out.

After adjusting fully tighten the lock nut.

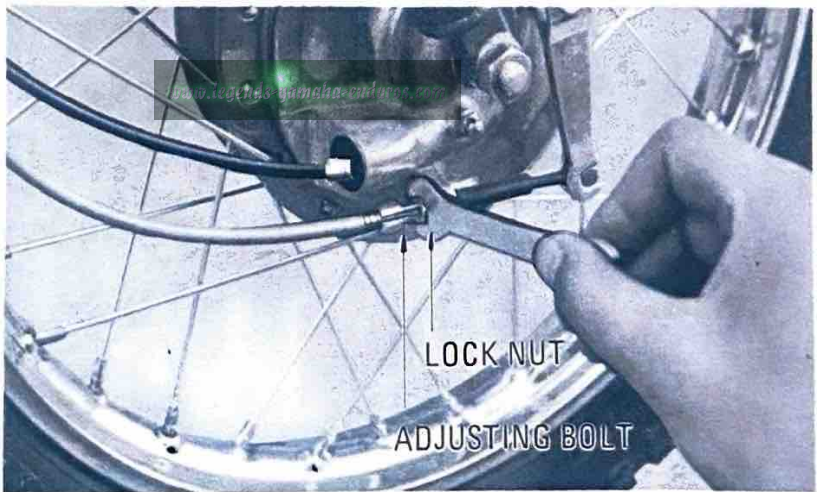
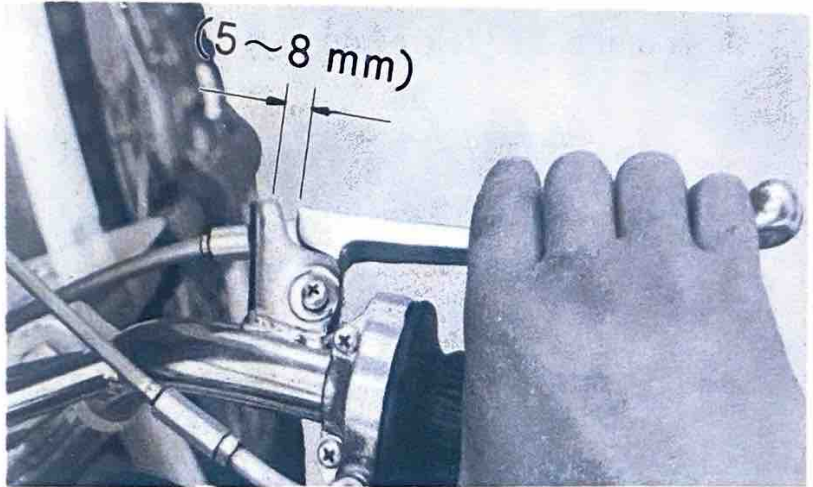

## Rear brake adjustment:

The correct free play of the rear brake pedal is about 1.0 in(25 mm). Adjust by turning the adjusting nut at the end on the rear brake rod a half turn at a time.

**Note:** Inspect the brake linings for wear and clean the brake shoes and drums every 2,000 miles (3,000 km). Always keep the shoes and drums free of oil.

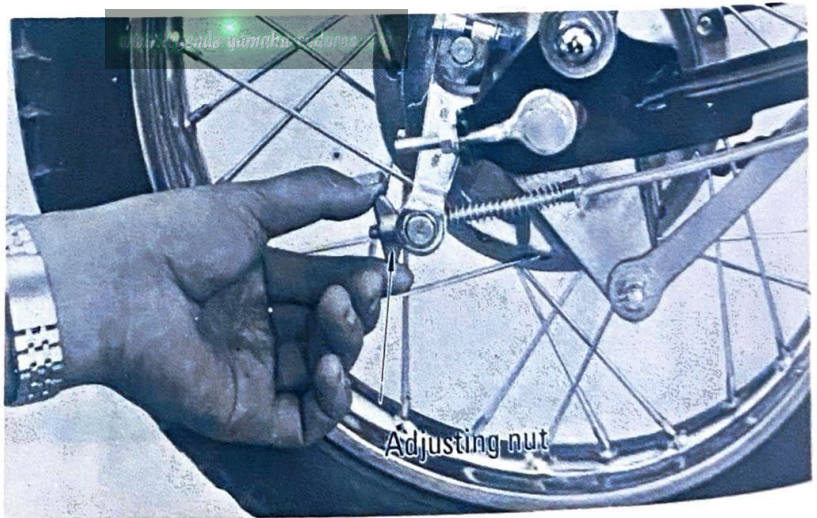
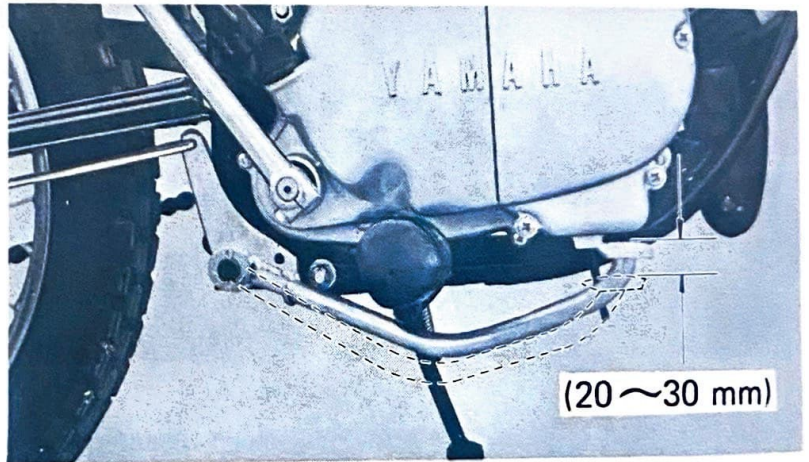



## Front wheel:

Work that might need to be done on the front wheel assembly includes tire or tube exchange, brake shoe replacement, hub/spokes/rim assembly replacement, and brake assembly maintenance and inspection. The following are the steps necessary to dismantle the front wheel step by step, and you should proceed with the steps until you have removed the part that you wish to replace. We suggest that you, as the owner, can replace everything but the hub, the spokes, or the rim.

To individually replace any of these parts requires that the spokes be "replaced". This should be done by a competent dealer as the spokes must be positioned and torqued correctly. If not done properly wheel alignment will not be correct and steering will be negatively affected. To carry out front wheel repair, you must remove the wheel.

1. Remove the brake cable and speedometer cable from the front wheel hub plate.

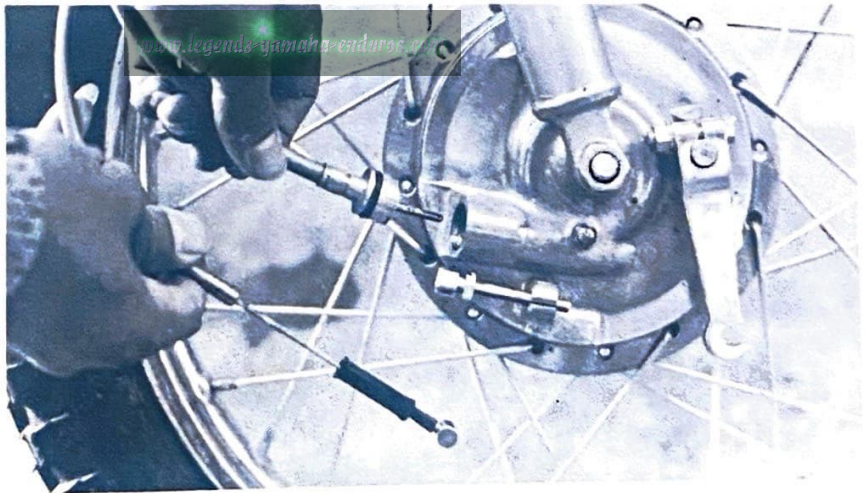



2. Remove the front wheel nut.

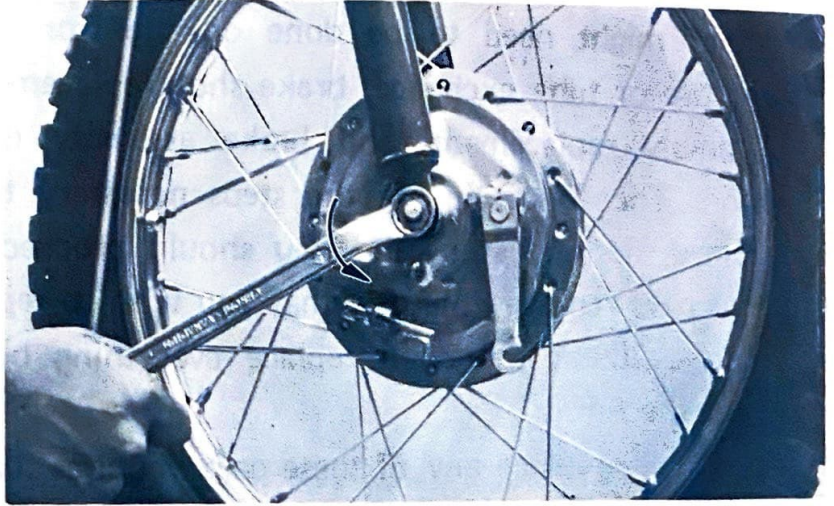

3. Remove the front axle by simultaneously twisting and pulling out on the axle.



4. Brace the front of the machine off the ground and remove the wheel assembly.

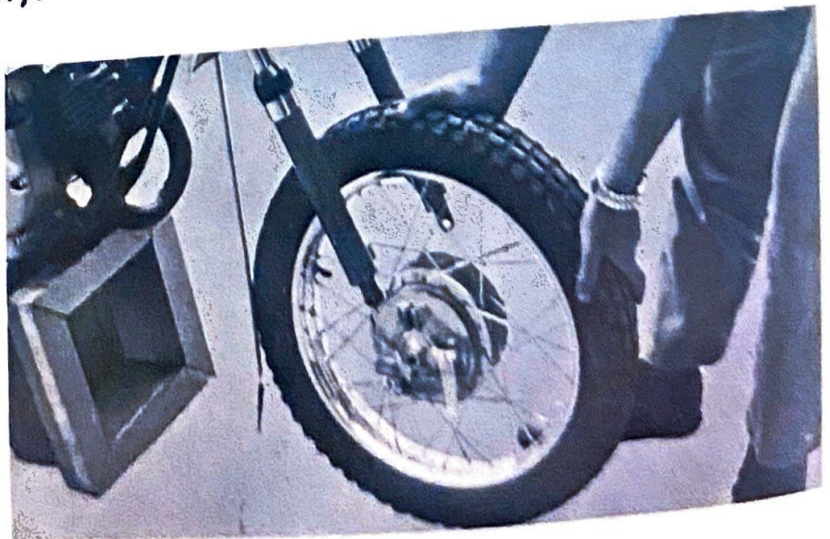

The brake plate can now be easily slipped out of the front wheel hub. The brake plate carries both brake shoes. They can be left in place on the brake plate for measurement, as shown below, or they can be lifted off for replacement or maintenance. The two brake shoes are held in place by a spring. This spring hold the two shoes to the brake actuating cam.

Removal of this spring or spreading it will allow the shoes to be lifted off. Whenever you have the brake plate off the wheel assembly, it is very good policy to apply a small amount of grease to the brake actuating cam.

Shown immediately below are two steps that must be performed periodically to maintain maximum stopping efficiency. The brake linings and brake drum must be in correct working condition, and these steps do much to guarantee perfect working order.

[www.legends-yamaha-enduros.com](http://www.legends-yamaha-enduros.com)





## 1. Brake shoe

Measure the outside diameter of the brake shoe set with slide calipers.

If it measures less than 104 mm (4.09 in.), replace it. Smooth out any rough shoe surface with sandpaper or with a file.

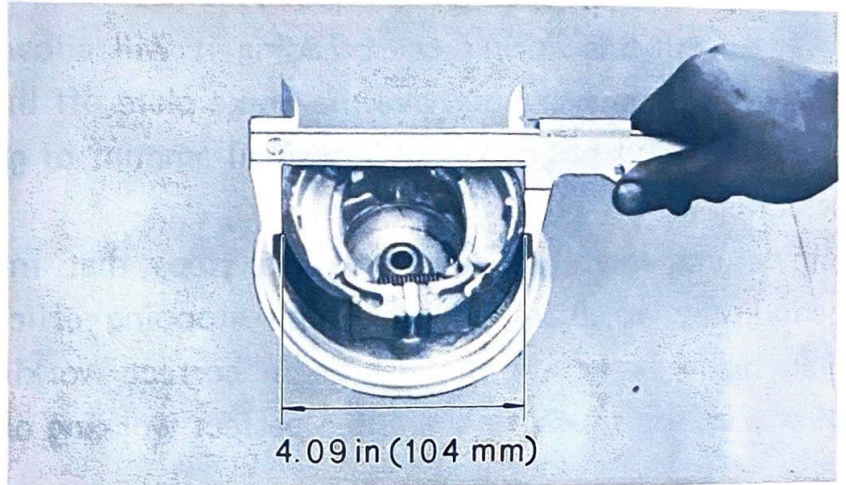

## 2. Brake drum

Oil or scratches on the inner surface of the brake drum will impair braking performance or result in abnormal noises.

Clean or smooth out the surface with a rag soaked in laquer thinner or with sandpaper.

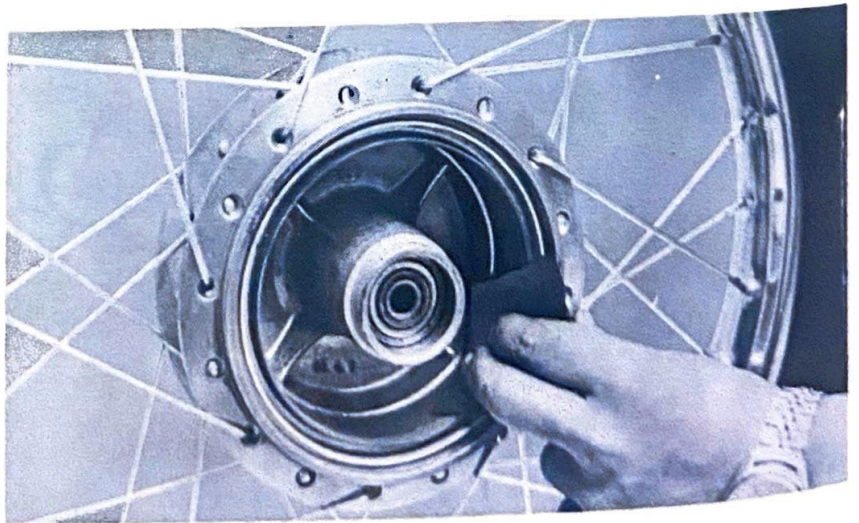



## Rear wheel:

A complete list of rear wheel parts that you can remove, certain precautions and limitations that must be adhered to, checking for wheel run-out, and checking for spoke tightness can all be found in the FRONT WHEEL section. In order for you to carry out those steps that are possible, a list of procedures is given explaining how to completely disassemble the rear wheel assembly.

1. Remove the tension bar and the brake rod from the rear shoe plate. Pay strict attention to the presence and location of the lock washer and cotter pin. These are safety parts and must be included during reassembly.

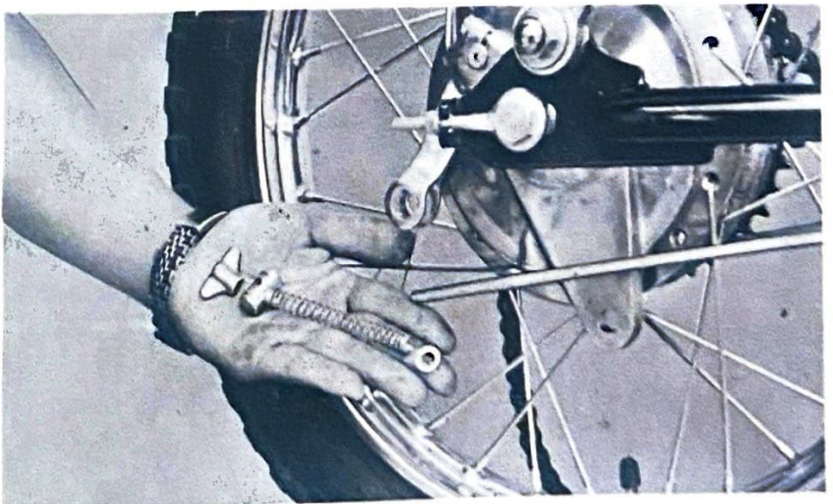
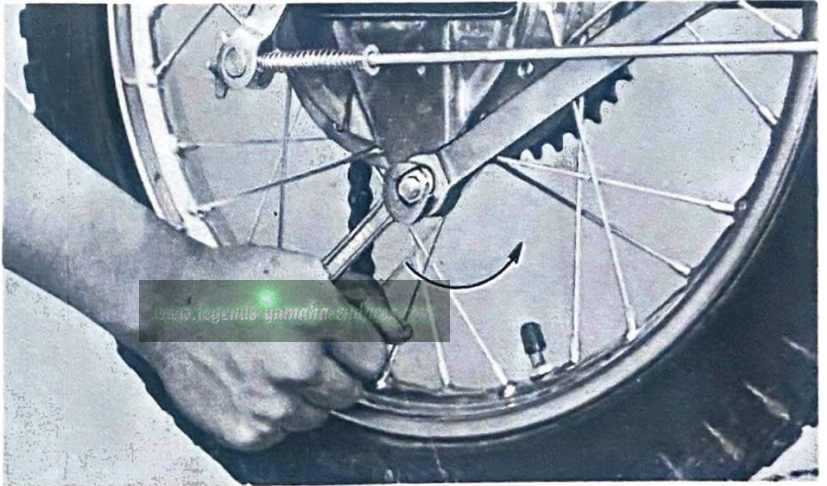

2. Loosen the chain tension adjusting nuts and bolts on both right and left sides.

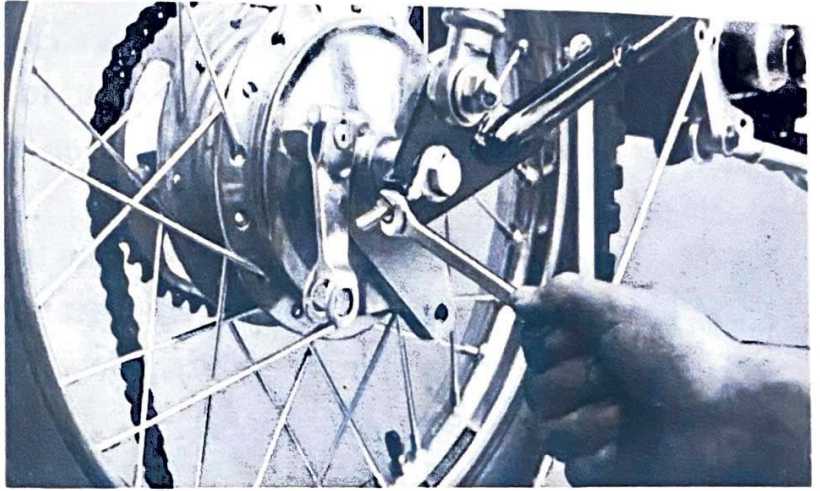

3. Remove the rear wheel shaft nut.

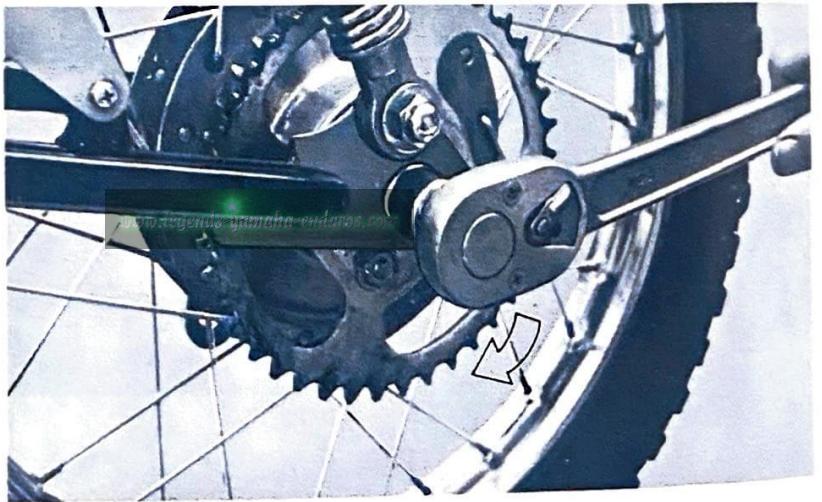

4. Push out the rear wheel shaft by striking it with a plastic tipped hammer.

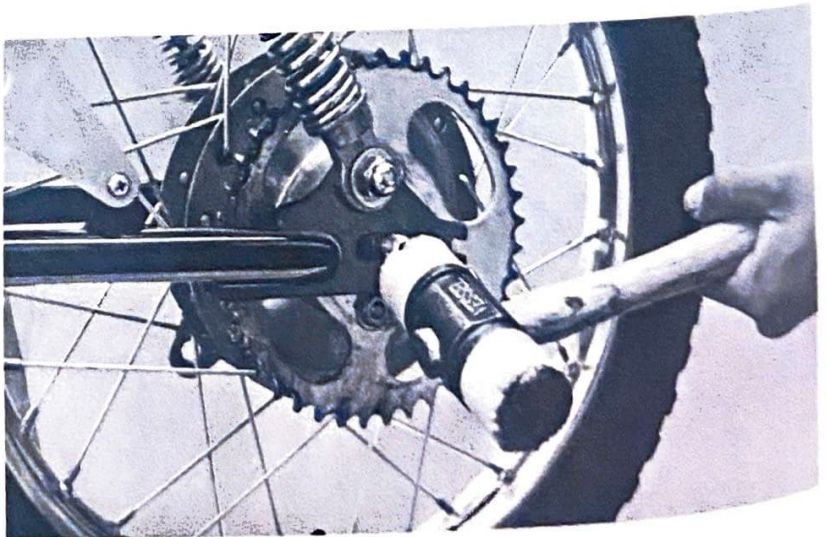



5. Remove the right-hand chain adjuster and distance collar.

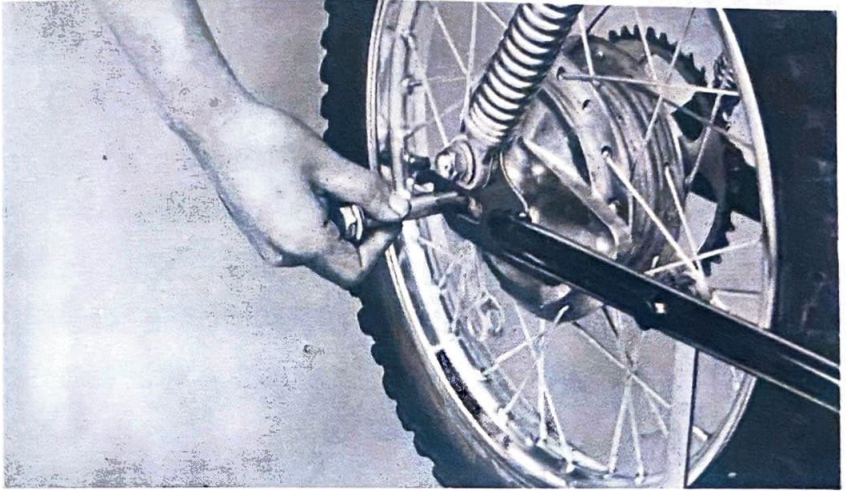

6. Remove the rear brake plate.

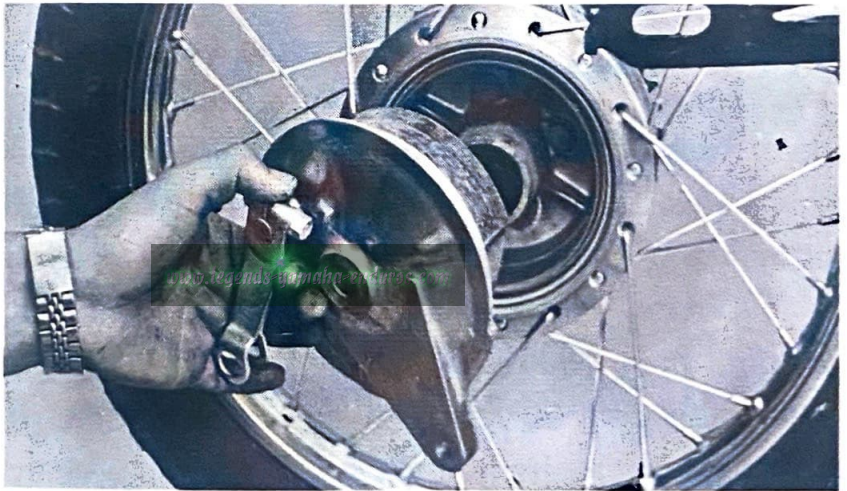

7. Lean the machine to the left and remove the rear wheel assembly.

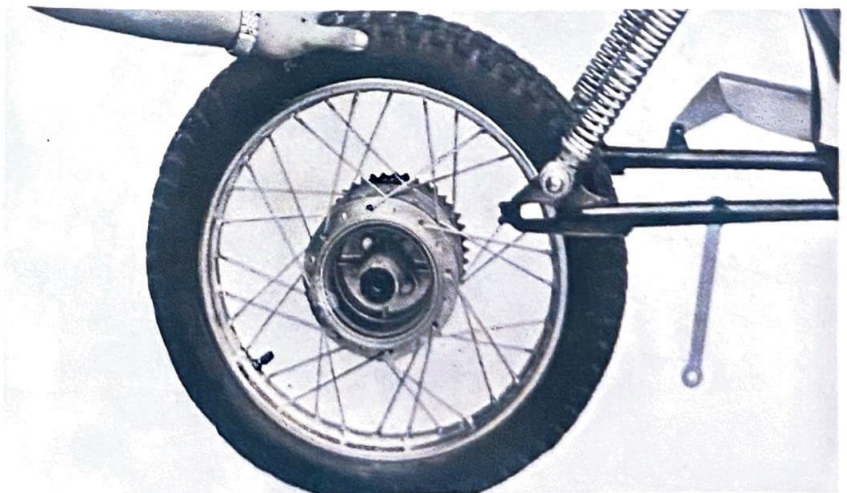



The brake plate carries both brake shoes. They can be left in place on the brake plate for measurement, or they can be lifted off for replacement or maintenance. The two brake shoes are held in place by two springs.

These springs hold one end of the two shoes to an anchor post, and the other end against the brake actuating cam. Removal of these springs, or spreading them, will allow the shoes to be lifted off. Whenever you have the brake plate off the wheel assembly, it is very good policy to apply a small amount of grease to the brake actuating cam.

### Tire repair:

Whether it is the front tire or the rear tire that you wish to change, the procedure of tire and tube removal is identical. Consider the explanation that follows as the proper method for both wheels.

First, remove the valve cap and valve stem lock nut. Empty all the air out of the tire. Use two tire removal irons (with rounded edges) and begin to work the tire bead over the edge of the rim, starting 180° opposite the tube stem. Take care to avoid pinching the tube as you do this. After you have worked one side of the tire completely off the rim, then you can slip the tube out. Be very careful not to damage the stem as you push it back out of the rim hole. If you are changing the tire itself, then finish the removal by working the tire off the same rim edge just previously mentioned.



Reinstalling the tire assembly can be accomplished by reversing the disassembly procedure. The only difference in procedure would be right after the tube has been installed, but before the second tire edge has been completely slipped onto the rim, inflate the tube. This removes any creases that might exist. Release the air and continue with reassembly. Also, right after the tire has been completely slipped onto the rim. Check to make sure that the stem is squarely in the center of the hole in the rim.

### Drive chain:

Because the chain consists of an extraordinary amount of parts that rub against one another, it is prone to wear if it is not maintained constantly and correctly. Without any lubrication, a chain can wear out within 500 miles. You should develop a habit of servicing the chain on a regular schedule. This habit is especially important since you will spend the major portion of your time riding in the dirt where dust and dirt can readily work into the chain links.

#### 1. Lubrication

There are several excellent pressure can lubricants available. Use a rag to wipe off any accumulation of dirt, then spray a liberal amount of lubricant of the chain at least every 100 miles.

#### 2. Cleaning

The chain has to be periodically removed from the machine and soaked in cleaning solvent. Completely saturate the chain with solvent to remove as much dirt as possible. Drain and dry the chain thoroughly. Immediately after the chain has dried completely, lubricate to prevent any rust from forming.



### 3. Adjustment

Proper drive chain up and down free play, with the rider in position and both wheels on the ground, should equal 20 mm(3/4") when measured at the center of the lower section of chain. Follow these steps to obtain the correct free play:

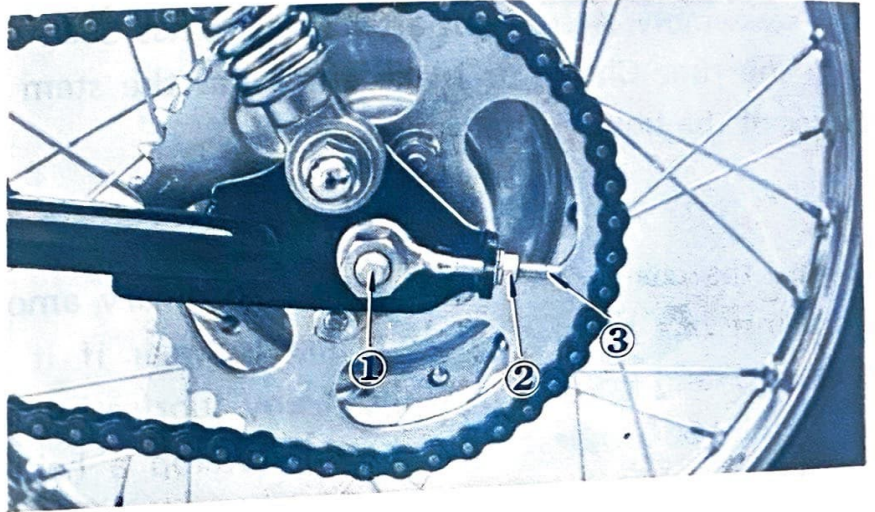

- a. Loosen the rear wheel nut
- b. Loosen the chain adjusting bolt lock nuts
- c. Rotate the adjusting bolts in or out, whichever is needed to obtain the correct free play, and at the same time make sure that both ends of the axle are positioned evenly. This can be checked by utilizing the marks on the very end of the swing arms, just above and to the rear of the rear wheel nuts.
- d. After completing the adjustment, retighten all the lock nuts.
- e. Finally, check for correct brake pedal operation as it could have changed due to the chain adjustment.

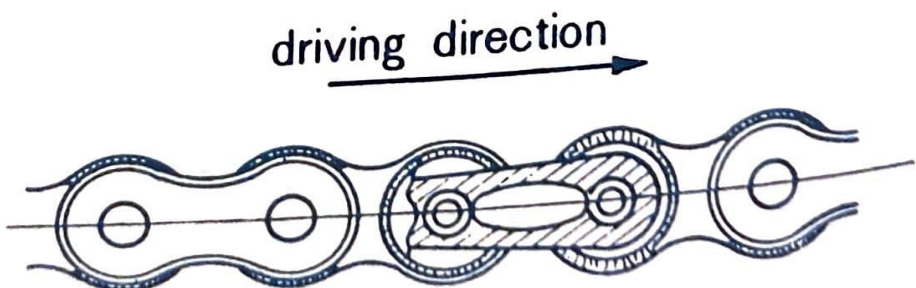



## Replacing the Gear Oil

The gear oil should be replaced before the oil level becomes too low. During the brake-in period, replace the oil every month or every 500 miles of operation. There-after, every three months or every 2,000 miles.

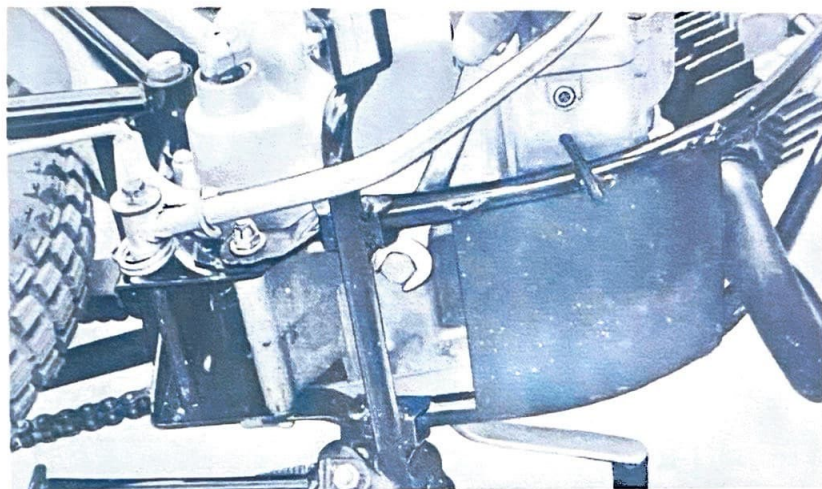

[www.legends-yamaha-enduros.com](http://www.legends-yamaha-enduros.com)

To drain the gear oil, the engine should be warmed up for 2 to 3 minutes. Then remove the oil drain plug from the crankcase bottom, and the oil can readily be drained off.

After draining the oil fully tighten the oil drain bolt. and fill with new oil to the specified level.

Oil..... SAE 10W/30 MOTOR OIL

Oil Amount ..... 0.6 ~ 0.65 quarts (0.6 ~ 0.65 liters)

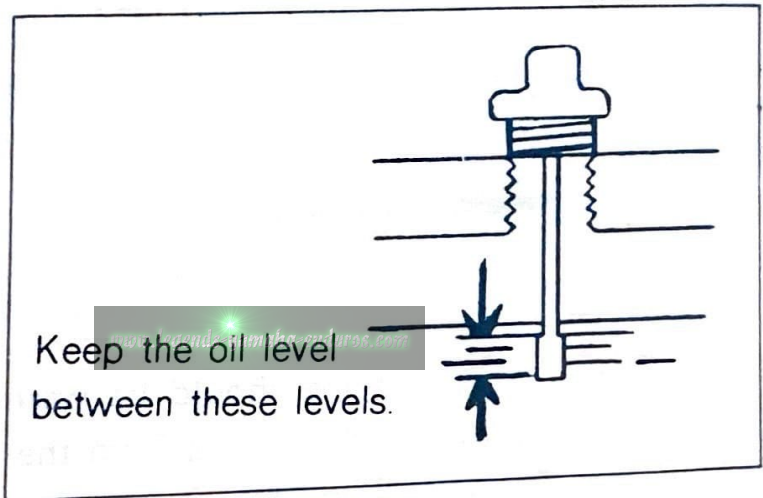
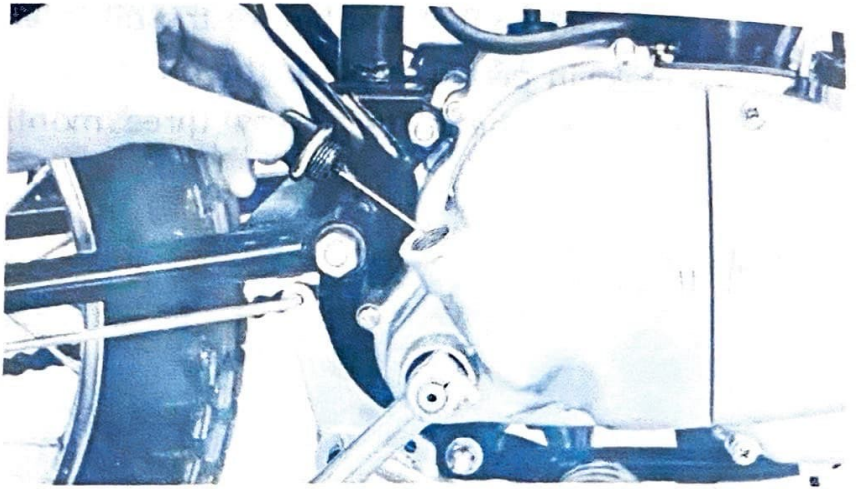

### Checking the carburetor:

Each carburetor is set by the factory after careful tests. Except for the following, do not change the carburetor setting without consulting your local Yamaha dealer.

#### a. Idling speed adjustments.

1. Lightly tighten the pilot air screw 1 and then back it off it 1 ½ turns.
2. Slightly loosen the adjusting screw of the throttle cable 3 connected to the accelerator grip, and start the engine.

3. After warming up the engine, turn the throttle stop screw 2 so that engine speed increases to 1200~1400 rpm.  
After this adjustment, loosen lock nut 5 to adjust the play of throttle cable 3 to in (0.5 ~ 1.0 mm); and turn throttle cable adjuster while pulling throttle cable 4 to check the adjustment. Then lock the throttle cable with lock nut 5 .

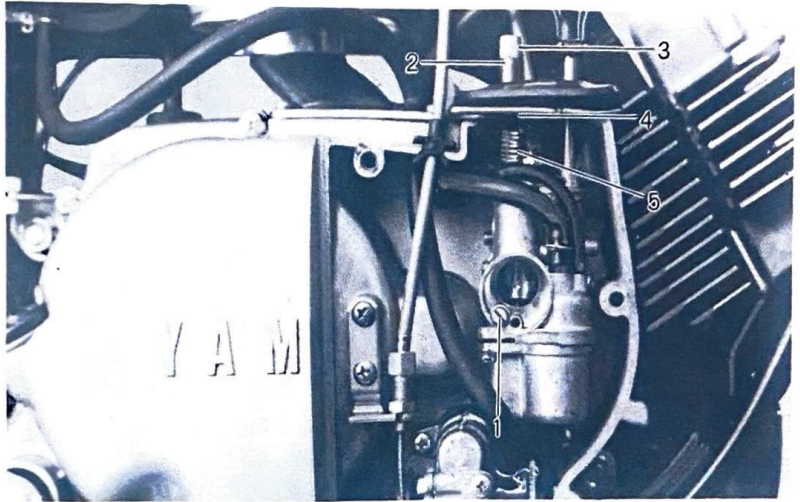

[www.legends-yamaha-enduros.com](http://www.legends-yamaha-enduros.com)

#### J. **Adjusting the pump cable.**

1. After adjusting the carburetor, adjust the pump cable which is coupled with the throttle valve.
2. Slightly turn the accelerator grip from the closed position so that free play of the accelerator grip is nil (In other words, the throttle valve is ready to open, after only another slight turning of the throttle is needed.)
3. Turn the pump cable adjusting nut so that the marking on the adjusting pulley is aligned with the guide pen.



## Air Filter

This model is equipped with a reuseable, oil impregnated, foam air filter. It must be removed and cleaned at least once a month, and more often if the motorcycle is ridden mainly in the dirt—preferably each time after you spend the entire day in the dirt (8- 10 hours operation).

- (1) Remove the air cleaner mounting bolt and loosen the air cleaner.

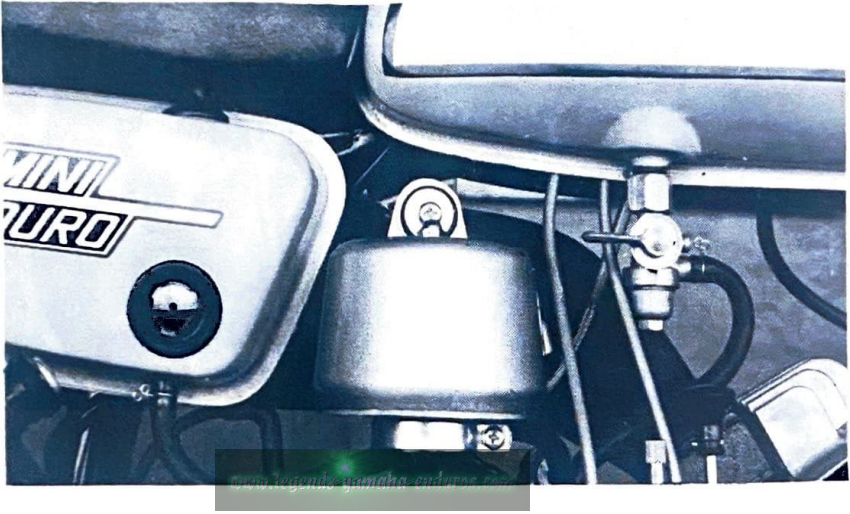

- (2) Remove the air cleaner case cap.



(3) The cleaner element can be pulled out.



[www.legenda-yamaha-enduros.com](http://www.legenda-yamaha-enduros.com)



## Cleaning the Fuel Petcock Filter:

The fuel petcock filter removes impurities from gasoline before they flow into the carburetor. A dirty filter clogs the system, and as a result, the engine will not run properly. Clean it from time to time. Remove the cup from the petcock and remove the filter. Wash it refully in gasoline and reinstall.

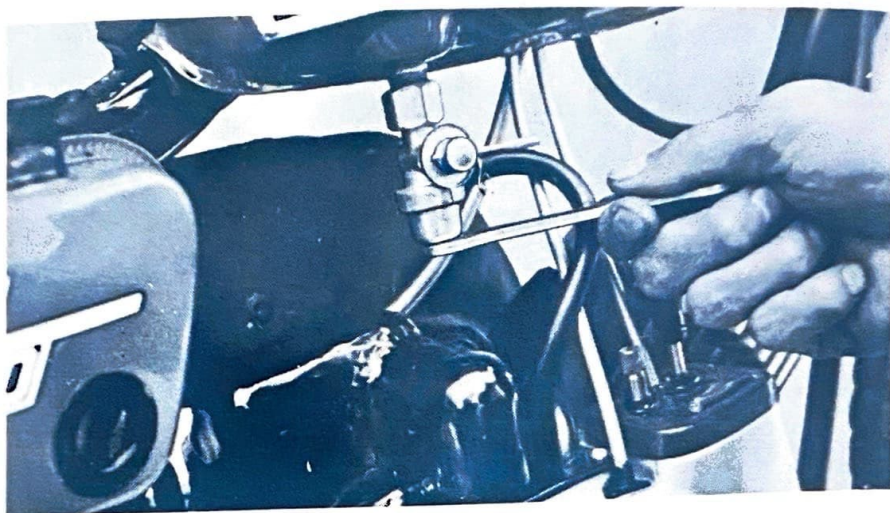

## Spark plug:

The spark plug in your machine can tell you a great deal as to how the engine is operating when you know how to "read" the plug. If the engine is operating correctly, and if it is being ridden correctly, then the tip of the white insulator in the spark plug will be a light tan color (standard plug is NGK B-7HS). If, when you remove the spark plug, it is very dark brown or black, then a plug with a hotter heat range is needed. This situation is quite common during the engine break-in period. If the insulator tip shows a very light tan color, or is actually white, or if the electrodes begin to melt, then a spark plug with a colder heat range is required. Again, if the spark plug insulator tip does not have a light tan color, have your dealer install a spark plug with a different heat range to correct the



situation. Do not attempt to experiment with different heat range spark plugs yourself, as it takes an experienced eye to gauge which spark plug to use.

It is all right though for you to replace the standard plug. Engine conditions can cause any spark plug to slowly break down. If deposits begin to build up, or if the electrodes finally become too worn, or if for any reason you believe the spark plug to not be functioning correctly, replace it. Be sure, when replacing the plug, that you always clean the gasket surface, that you use a new gasket, and that the spark plug is torqued to 20–25 ft/lbs. Also wipe off any grime that might be present on the surface of the spark plug.

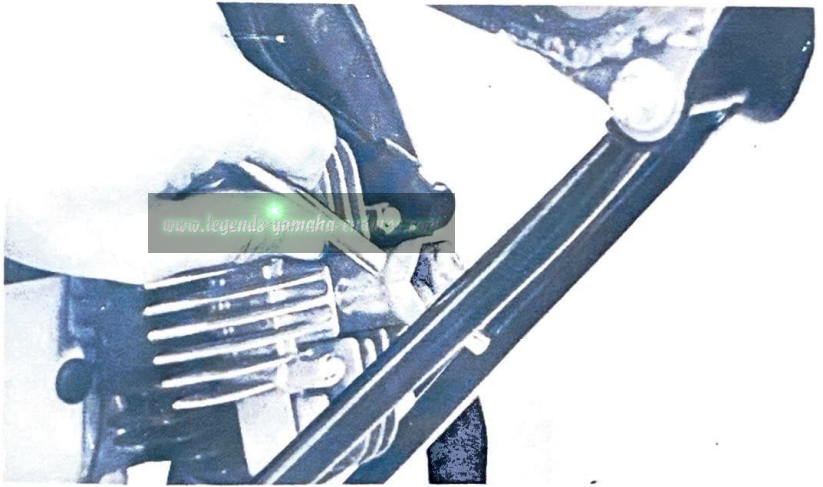

The plug can be taken out to be cleaned and gapped. As long as deposit build-up on the insulator is not extreme, you can use a spark plug cleaner to quickly remove the deposits. Use a wire type feeler gauge to set the electrode gap at 0.08"–0.024" (0.5 mm–0.6 mm).

## Cleaning the Muffler:

Carbon build-up in the muffler will adversely affect engine performance. It should be cleaned at least twice a year.

- 1) Remove the bolts from the muffler under the seat, and lightly tap the exhaust pipe ring nut with a soft hammer, then unscrew the ring nut and remove the muffler.

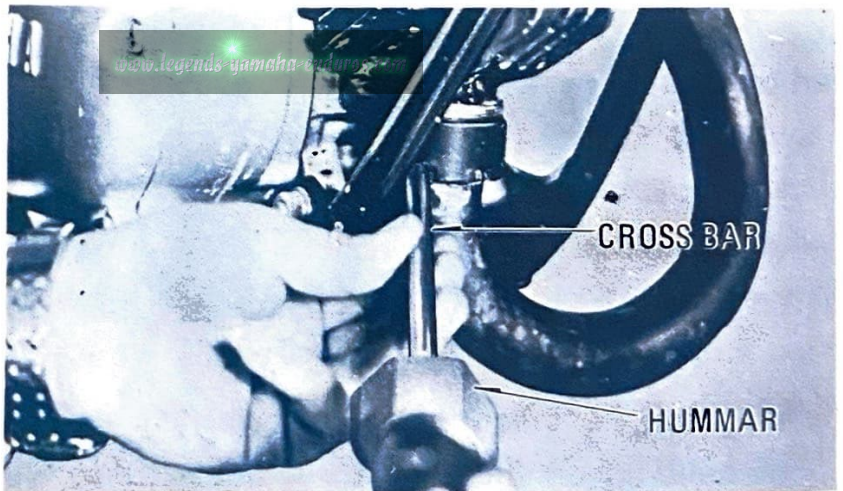
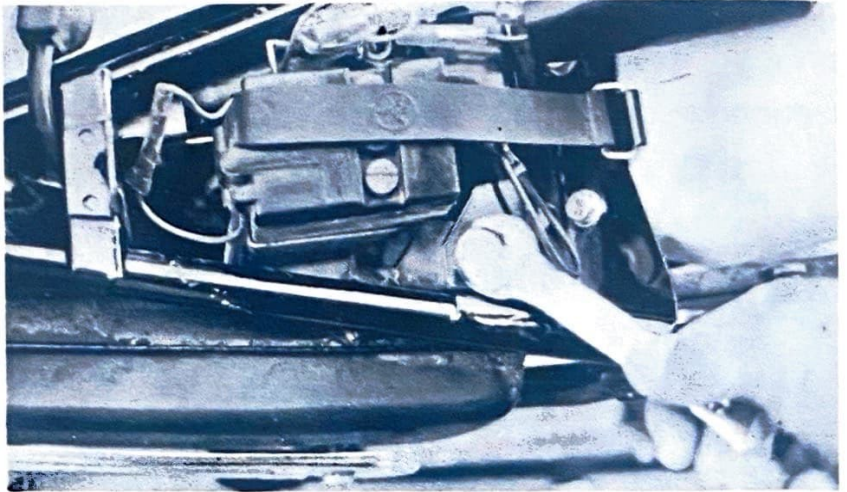

- 2) Next, remove the bolt anchoring the inner silencer to the muffler, and take out the silencer.

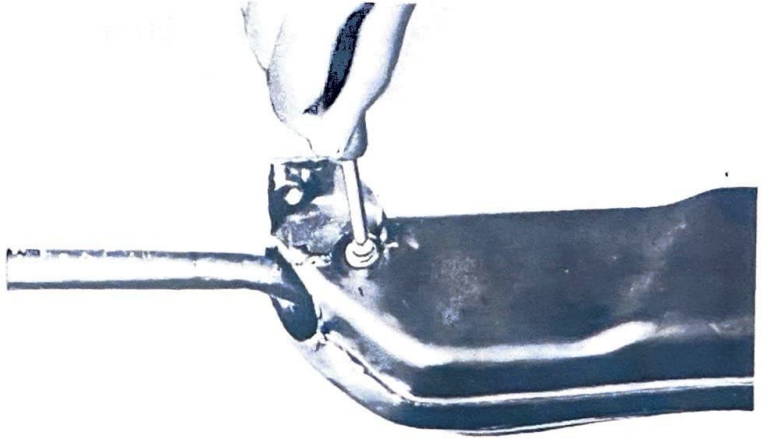

- 3) Scrape off the carbon with a wire brush, and lightly tap the silencer so that the carbon will be dislodged. If carbon still remains, heat the cylinder with a torch and tap it. The carbon then be easily removed.

### **Cleaning the Combustion Chamber and Piston:**

Carbon deposits in the combustion chamber, on the head of the piston, and in the exhaust port are a constant cause of engine power loss. Decarbonization of these parts is relatively simple, requiring only a few tools.



A torque wrench is one of the necessary tools. Going any further though, such as removing the carbon from ring grooves, should be done by a certified mechanic, as this requires cylinder removal.

Begin this servicing step by gradually loosening the four cylinder retaining nuts, in a "cross" pattern. **DO NOT LOOSEN EACH NUT COMPLETELY ALL AT ONCE**, but work around the cylinder head, loosening each nut  $\frac{1}{2}$  turn at a time. Slip the head off and use a dull or round edge scraper to remove the carbon from the combustion chamber (do not remove the spark plug). The round end of a hacksaw blade works quite well. Use a rag dipped in solvent and thoroughly clean the area. Do not scratch the gasket surface.

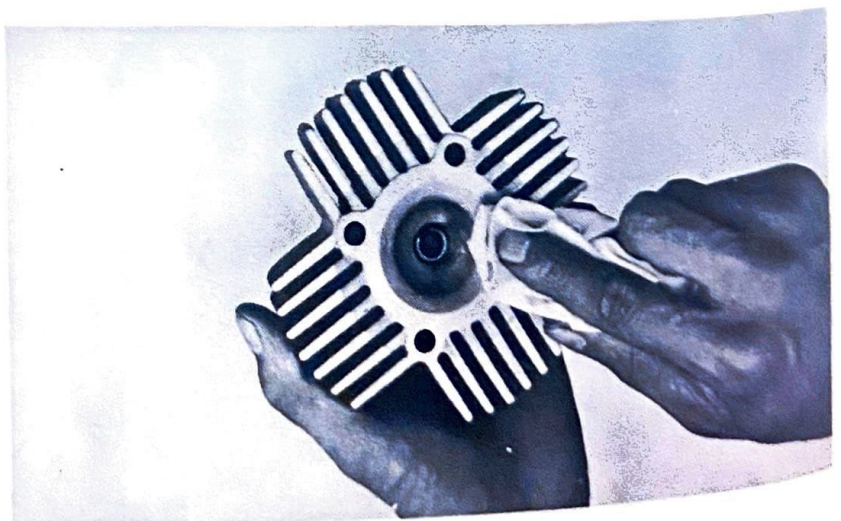

Bring the piston up to the very top and use the same scraping tool to remove the carbon from the top of the piston. Blow off as much of the loosened carbon as possible, then use the solvent soaked rag to pick up as much of the rest as possible.

Next, rotate the piston as far down as possible. Slip a dry rag down over the piston for protection. Disconnect the muffler. Very carefully use a small scraper and remove the carbon from the port opening (take care that it does not fall back into the cylinder). As soon as possible, scrape the carbon from the exhaust port from the outside opening.

The head can now be put back onto the cylinder. Carefully wipe off the gasket surfaces of both parts. Position the head gasket (which should be a new one) on the cylinder. Slip the head into place and tighten the four retaining bolts until they are finger tight. Use the torque wrench to tighten them further. Total torquing pressure is 15 ft/lbs., but you should torque all four nuts in pattern and in two progressive steps of increasing torque (example: 10 lbs., 15 lbs.)

### Steering:

Periodically you should check for any looseness in the steering assembly. Do this by blocking the front end off the ground, grasping the bottom of the forks, and gently rocking the fork assembly backward and forward. You will feel any looseness in the steering assembly bearings. If any exists, do not attempt to correct it yourself but let your dealer make the adjustment with the correct tools. Also, these same front fork bearings must be lubricated every 3,000 miles. This the dealer must also do.



## Adjusting the Headlight Beam Angle:

- \* To adjust the headlight beam angle, loosen the light mounting nut in the headlight, and move the light to face upward or downward.

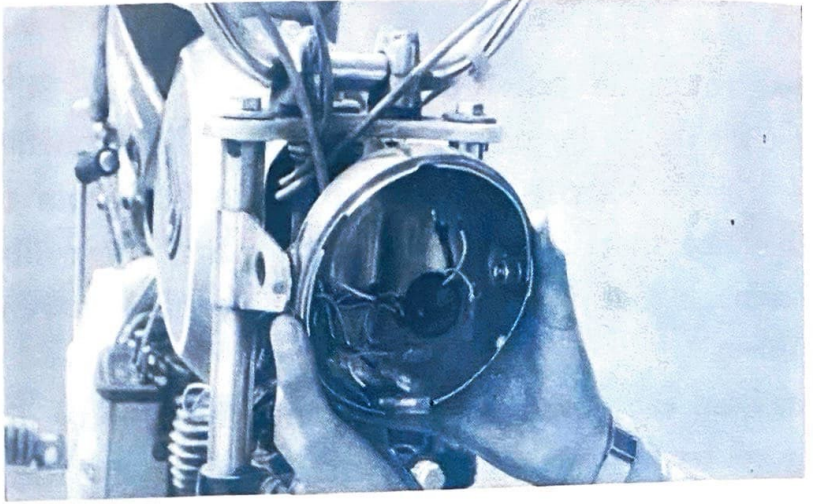

[www.legends-yamaha-enduros.com](http://www.legends-yamaha-enduros.com)



# YAMAHA MINI ENDURO 60JT2 CIRCUIT DIAGRAM

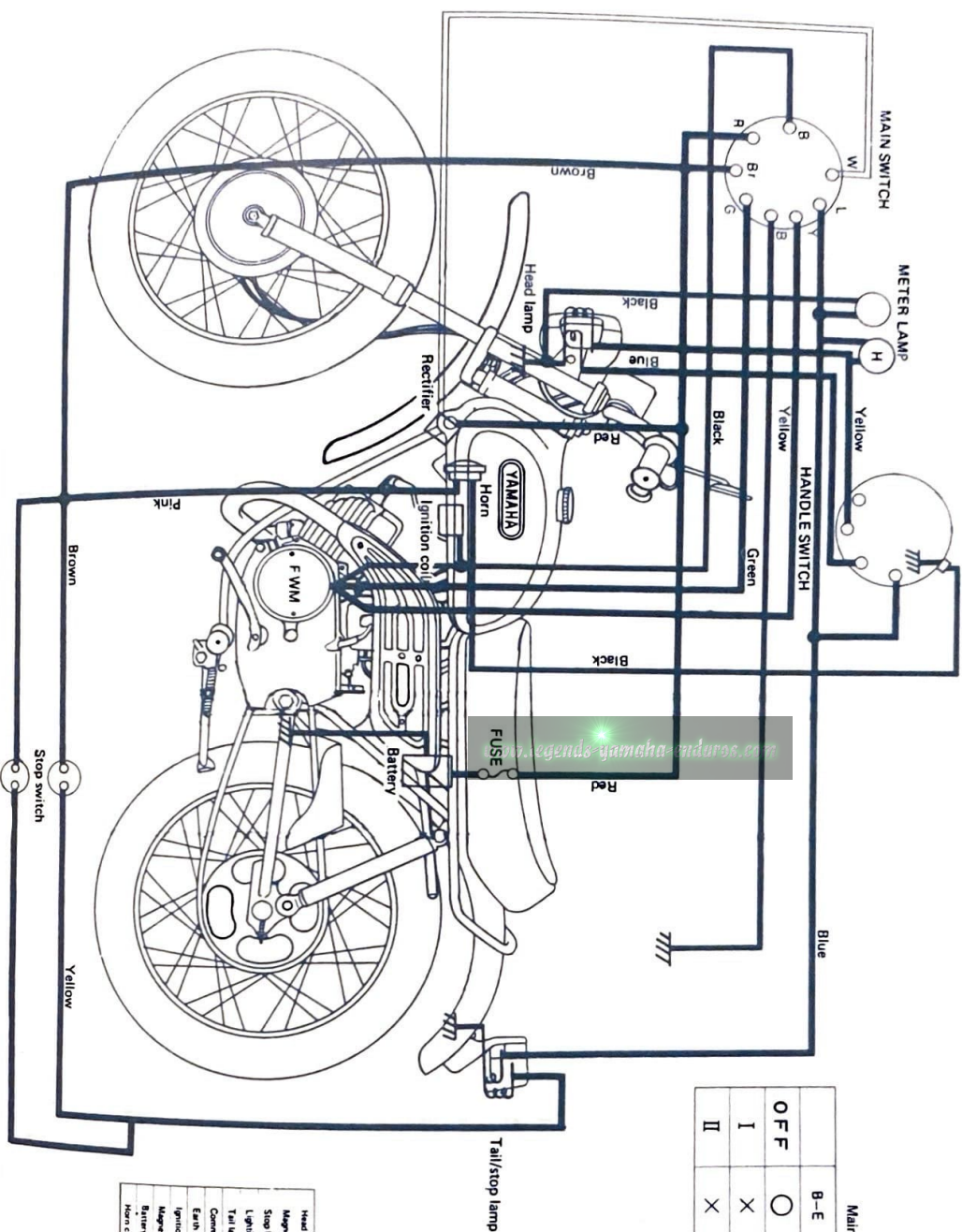

Main Switch connecting

	B-E	R-Br	G-W	W-Y-B1
OFF	○	×	×	×
I	×	○	○	×
II	×	○	×	○

chart of wire colors

Head lamp main circuit	Yellow
Magneto nighttime charging circuit	Yellow
Stop lamp circuit	Yellow
Lighting circuit	Blue
Tail lamp circuit	Blue
Common circuit	Brown
Earth circuit	Brown
Ignition primary circuit	Black
Magneto daytime charging circuit	Green
Battery (+) circuit	Red
Alarm circuit	Pink

[www.legends-yamaha-enduros.com](http://www.legends-yamaha-enduros.com)

[www.legenda-yamaha-enduros.com](http://www.legenda-yamaha-enduros.com)



[www.legends-yamaha-enduros.com](http://www.legends-yamaha-enduros.com)

[www.legends-yamaha-enduros.com](http://www.legends-yamaha-enduros.com)



 **YAMAHA MOTOR CO, LTD.**

Printed in Japan

47.3 × 40