

NOTICE

This manual was written by the Yamaha Motor Company primarily for use by Yamaha dealers and their qualified mechanics. It is not possible to put an entire mechanic's education into one manual, so it is assumed that persons using this book to perform maintenance and repairs on Yamaha motorcycles have a basic understanding of the mechanical concepts and procedures inherent in motorcycle repair technology. Without such knowledge, attempted repairs or service to this model may render it unfit to use and/or unsafe.

Escorts Ltd. is continually striving to improve all models manufactured. Modifications and significant changes in specifications or procedures will be forwarded to all authorized dealers and will, where applicable, appear in future editions of this manual.

ESCORTS LTD. MSD
SERVICE DEPARTMENT

HOW TO USE THIS MANUAL

PARTICULARLY IMPORTANT INFORMATION

This material is distinguished by the following notation.

NOTE:

A NOTE provides key information to make procedures easier or clearer.

CAUTION:

A CAUTION indicates special procedures that must be followed to avoid damage to the motorcycle.

WARNING:

A WARNING indicates special procedures that must be followed to avoid injury to a motorcycle operator or person inspecting or repairing the motorcycle.

MANUAL FORMAT



















All of the procedures in this manual are organized in a sequential, step-by-step format. The information has been compiled to provide the mechanic with an easy to read, handy reference that contains comprehensive explanations of all disassembly, repair, assembly, and inspection operations.

In this revised format, the condition of a faulty component will precede an arrow symbol and the course of action required will follow the symbol, e.g.,

- Bearings
Pitting/Damage → Replace.

EXPLODED DIAGRAM

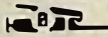
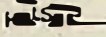
Each chapter provides exploded diagrams before each disassembly section for ease in identifying correct disassembly and assembly procedures.

① GEN INFO 	② INSP ADJ 	
③ ENG 	④ CARB 	
⑤ CHAS 	⑥ ELEC 	
⑦ APPX 	⑧ 	
⑨ 	⑩ 	
⑪ 	⑫ 	
⑬ 	⑭ 	
⑮ 	⑯ 	⑰ 
⑱ 	⑲ 	⑳ 

ILLUSTRATED SYMBOLS (Refer to the illustration)

Illustrated symbols ① to ⑦ are designed as thumb tabs to indicate the chapter's number and content.

- ① General information
- ② Periodic inspection and adjustment
- ③ Engine
- ④ Carburetion
- ⑤ Chassis
- ⑥ Electrical
- ⑦ Appendices







Illustrated symbols ⑧ to ⑬ are used to identify the specifications appearing in the text.

- ⑧ Filling fluid
- ⑨ Lubricant
- ⑩ Tightening
- ⑪ Wear limit, clearance
- ⑫ Engine speed
- ⑬  V. A.

Illustrated symbols ⑭ to ⑳ in the exploded diagram indicate grade of lubricant and location of lubrication point.

- ⑭ Apply locking agent (LOCTITE or equivalent)
- ⑮ Apply engine oil
- ⑯ Apply gear oil
- ⑰ Apply molybdenum disulfide oil
- ⑱ Apply wheel bearing grease
- ⑲ Apply lightweight lithium soap base grease
- ⑳ Apply molybdenum disulfide grease

INDEX

GENERAL INFORMATION	 GEN INFO 1
PERIODIC INSPECTIONS AND ADJUSTMENTS	 INSP ADJ 2
ENGINE OVERHAUL	 ENG 3
CARBURETION	 CARB 4
CHASSIS	 CHAS 5
ELECTRICAL	 ELEC 6
APPENDICES	 APPX 7



CHAPTER 1 GENERAL INFORMATION

MOTORCYCLE IDENTIFICATION _____	1 -1
FRAME SERIAL NUMBER _____	1-1
ENGINE SERIAL NUMBER _____	1-1
IMPORTANT INFORMATION _____	1-2
ALL REPLACEMENT PARTS _____	1-2
GASKETS, OIL SEALS, AND O-RINGS _____	1-2
LOCK WASHERS/PLATES AND COTTER PINS _____	1-2
BEARINGS AND OIL SEALS _____	1-2
CIRCLIPS _____	1-3
SPECIAL TOOLS _____	1-3
FOR ENGINE SERVICE _____	1-3
FOR CHASSIS SERVICE _____	1-5
FOR TUNE-UP _____	1-6
FOR ELECTRICAL COMPONENTS _____	1-6



**GENERAL
INFORMATION**

MOTORCYCLE IDENTIFICATION

FRAME SERIAL NUMBER

The frame serial number ① is stamped into the right side of the steering head pipe.

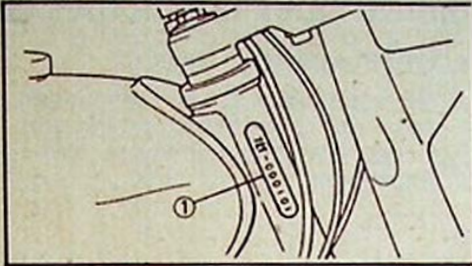

ENGINE SERIAL NUMBER

The engine serial number ① is stamped into the left side of the engine.

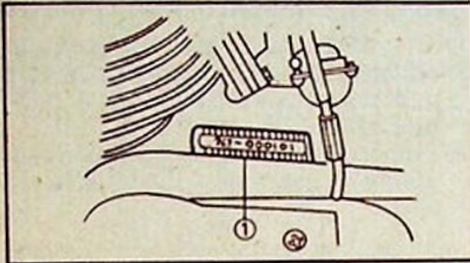

NOTE:

The first three digits of these numbers are for model identifications; the remaining digits are the unit production number.

Starting Serial Number:

RX100 _____ 1L1-000101

NOTE:

Designs and specifications are subject to change without notice.



IMPORTANT INFORMATION

IMPORTANT INFORMATION

ALL REPLACEMENT PARTS

1. We recommend to use Yamaha genuine parts for all replacements. Use oil and/or grease recommended by Escorts for assembly and adjustment.

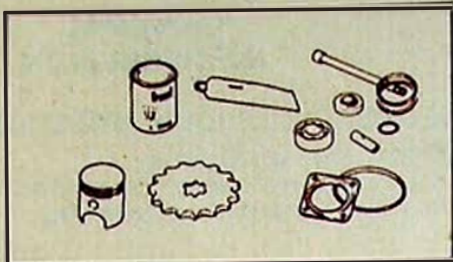

GASKETS, OIL SEALS, AND O-RINGS

1. All gaskets, seals, and O-rings should be replaced when an engine is overhauled. All gasket surfaces, oil seal lips, and O-rings must be cleaned.
2. Properly oil all mating parts and bearings during reassembly. Apply grease to the oil seal lips.

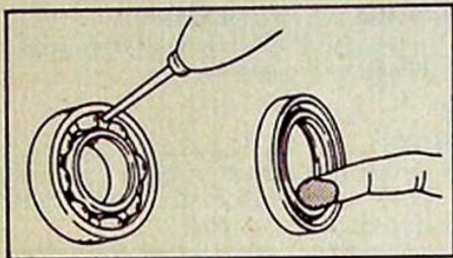

LOCK WASHERS/PLATES AND COTTER PINS

1. All lock washers/plates and cotter pins must be replaced when they are removed. Lock tab(s) should be bent along the bolt or nut flat(s) after the bolt or nut has been properly tightened.

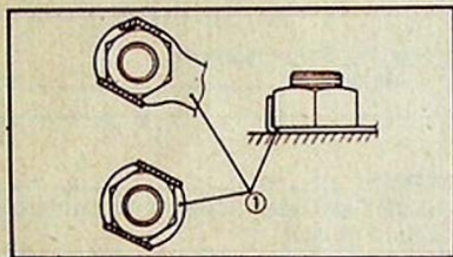

BEARINGS AND OIL SEALS

1. Install the bearings and oil seal with their manufacturer's marks or numbers facing outward. (In other words, the stamped letters must be on the side exposed to view.) When installing oil seal(s), apply a light coating of light-weight lithium base grease (eg. Servo Grease M.P.) to the seal lip(s). Oil the bearings liberally when installing.

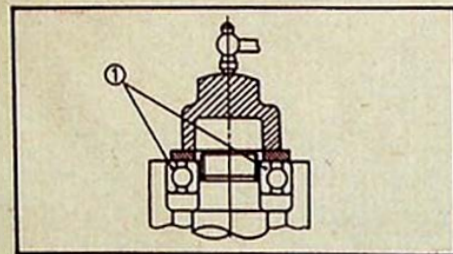

CAUTION:

Do not use compressed air to spin the bearings dry. This causes damage to the bearing surfaces.

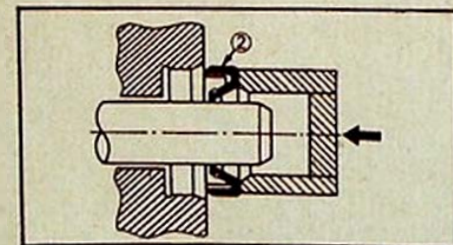



SPECIAL TOOLS

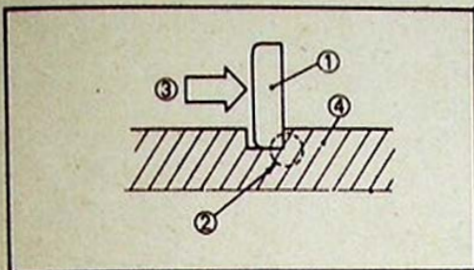

CIRCLIPS

1. All circlips should be inspected carefully before reassembly. Always replace piston pin clips after one use. Replace distorted circlips. When installing a circlip (1) make sure that the sharp-edged corner (2) is positioned opposite to the thrust (3) it receives. See the sectional view.

(4) Shaft

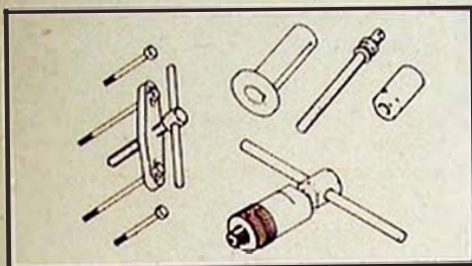

SPECIAL TOOLS

The proper special tools are necessary for complete and accurate tune-up and assembly. Using the correct special tool will help prevent damage caused by the use of improper tools or improvised techniques.

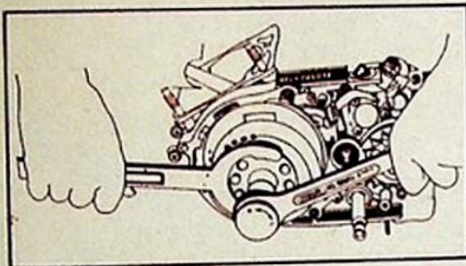

FOR ENGINE SERVICE

1. Flywheel Holding Tool
ESM-10000201

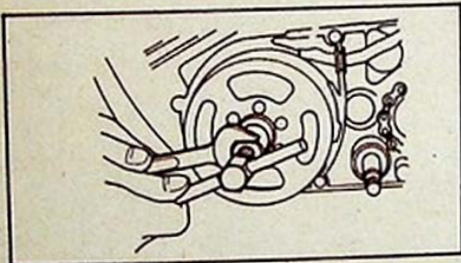
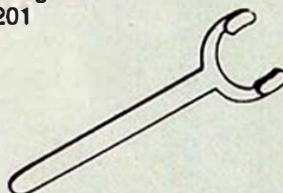

2. Flywheel Puller
ESM-10000202

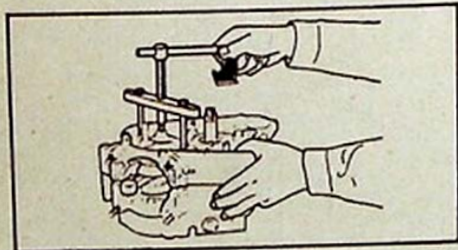
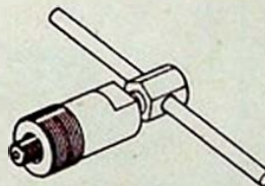

3. Crankcase Separating Tool
ESM-10000265

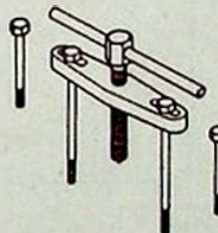



SPECIAL TOOLS

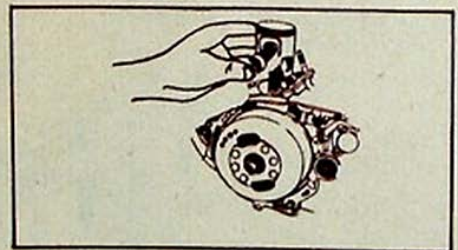
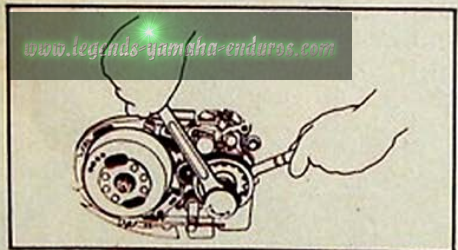
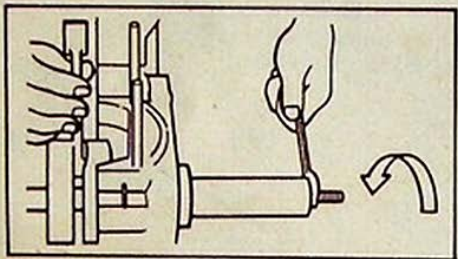
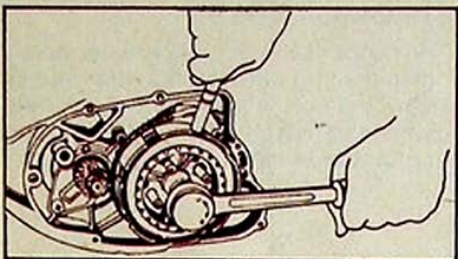
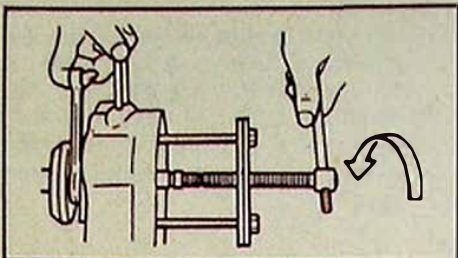

4. Clutch Holding Tool
ESM-10000233

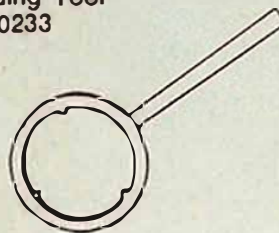

5. Crank Installing Tool
ESM-10000266

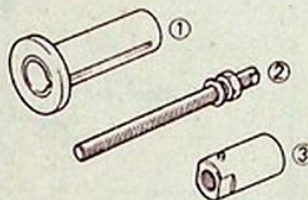

- 1 Pot
- 2 Bolt
- 3 Adapter

6. Driving Sprocket Holder
ESM-10000205

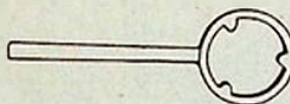

7. Piston Pin Replacer
ESM-10000207

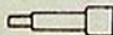



SPECIAL TOOLS

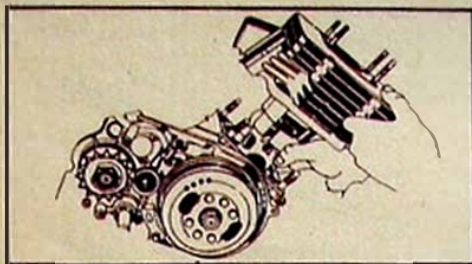

- 8. Piston Ring Compressor
ESM-100000210



- 9. Punch
ESM-100000222
For Crank-Shaft Seal



- 10. Punch
ESM-100000233
For Gear Shaft Seal

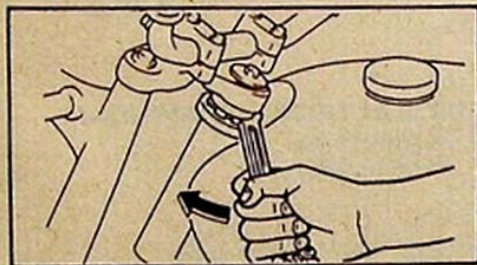

FOR CHASSIS SERVICE

- 1. Steering Nut Wrench
ESM-100000221

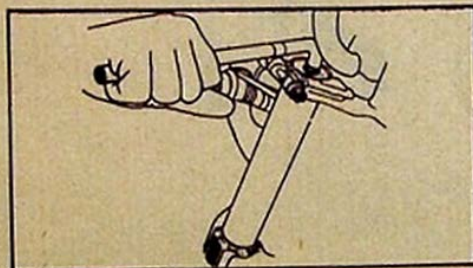
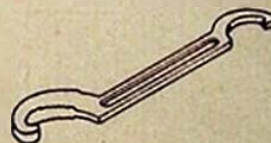

- 2. Front Fork Top Plug Spanner
ESM-100000214



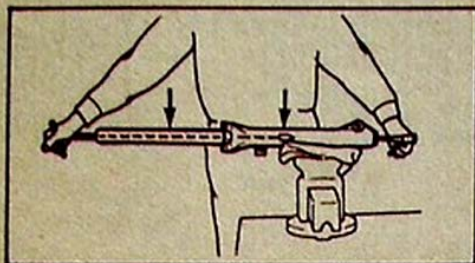

3. T Handle
ESM-100000213

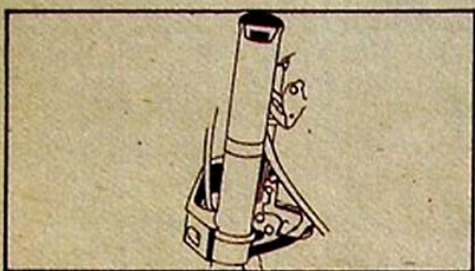
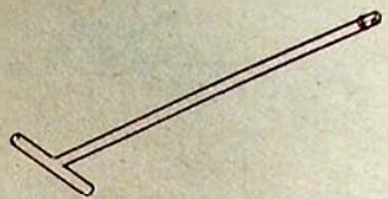

4. Front Fork Inner Tube Adjuster
ESM-100000264

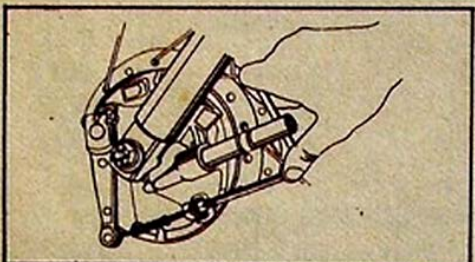
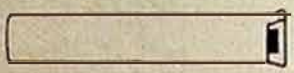

5. Speedometer Gear Nut Spanner
ESM-100000237

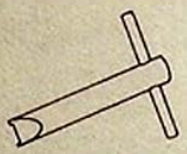

FOR ELECTRICAL COMPONENTS

1. Pocket Tester
ESM-100000270

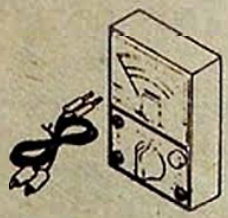

CHAPTER 2 PERIODIC INSPECTIONS AND ADJUSTMENTS

NOTES ON MAINTENANCE	2-1
PERIODIC MAINTENANCE/LUBRICATION	2-3
ENGINE	2-6
SPARK PLUG	2-6
AIR CLEANER ELEMENT	2-6
TRANSMISSION OIL	2-6
AUTOLUBE PUMP	2-7
CARBURETTOR	2-8
CLUTCH	2-9
CHASSIS	2-10
BRAKE	2-10
TYRE	2-11
DRIVE CHAIN	2-11
STEERING HEAD	2-12
ELECTRICAL	2-13
BATTERY	2-13



NOTES ON MAINTENANCE



1. Thoroughly clean the frame and engine of dirt and dust in order to prevent them from entering the inside of the engine.

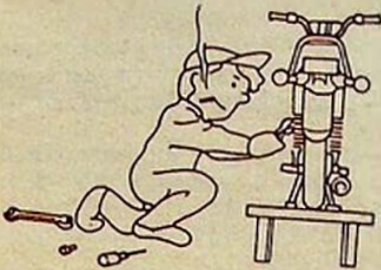

2. Keep off fire.

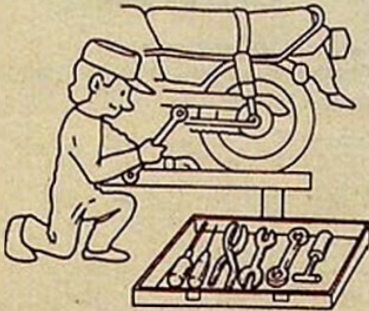

3. When the special tools are required, be sure to use them so that damage to the motorcycle parts can be avoided. Always use the right tools and instruments for the right purposes. (Avoid using an open-end wrench as much as possible, in place of a box or socket wrench.)



4. Always use a new gasket (packing), O-ring, cotter pin, circlip, lock washer, etc. for repairs. Also use genuine Yamaha parts, oil and grease, or those recommended by Escorts. Avoid using other brands.

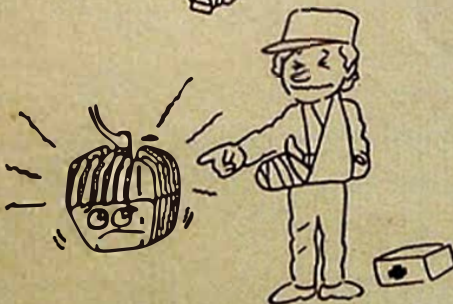

5. During service, take special care so that you don't get injured or burnt from the engine, exhaust pipe or muffler.



CLUTCH/BRAKE

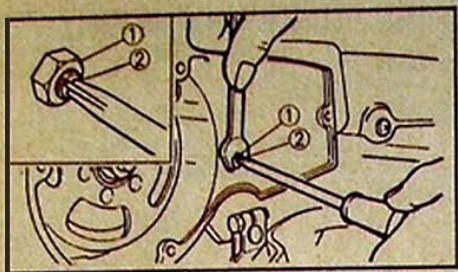

4. Loosen:
 - Locknut ①
5. Screw in adjuster ② until tight and back it out 1/4 turn.
6. Tighten:
 - Locknut ①

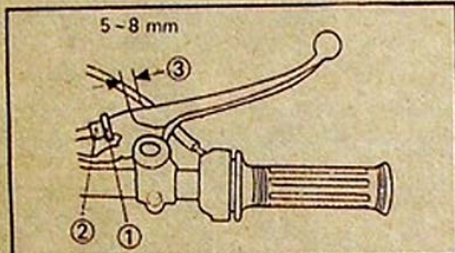

CHASSIS BRAKE

Front

1. Loosen:
 - Locknut ①
2. Adjust:
 - Free play by adjuster ②
3. Tighten:
 - Locknut ①
 - ③ 5~8 mm



Rear

1. Adjust:
 - Free play ① by turning the adjuster ② (Ref. Page 2-11)

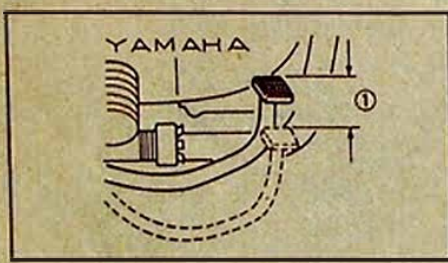

① 20~30 mm

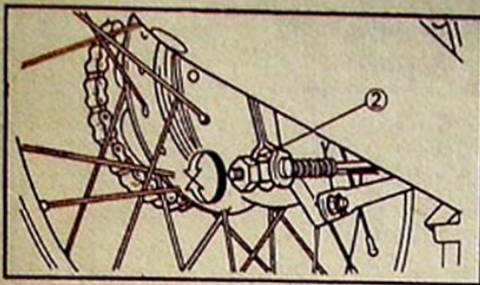

② Adjuster

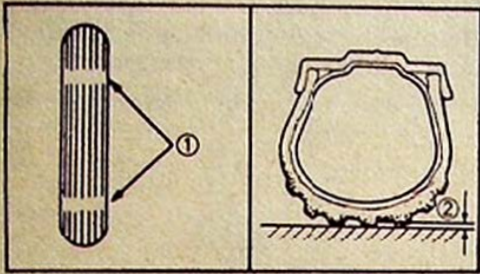

TYRE

1. Inspect:
 - Tyre wear

	Wear Limit:
	1 mm

- ① Wear indicator
- ② Replacement limit 1 mm

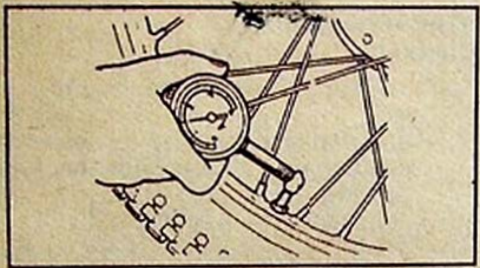

2. Check:
 - Air pressure

MAXIMUM LOAD*	162 Kg.	
	Front	Rear
Single Rider	1.5 kg /cm ² , (22 psi)	2.0 kg /cm ² , (28 psi)
Double Rider	1.5 kg /cm ² , (22 psi)	2.3 kg /cm ² , (32 psi)

* Load is the total weight of cargo, rider, passenger, and accessories.

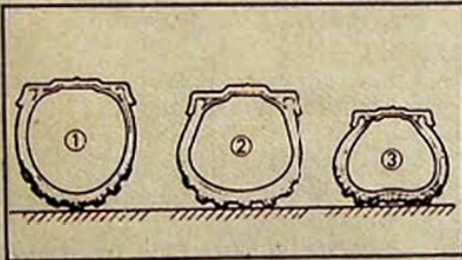

- ① Too high — Risky — Poor Road holding
- ② Good — Good & safe riding
- ③ Too low — Causes higher tyre wear
fuel economy low.

DRIVE CHAIN Slack Check

1. Remove:
 - Rubber cap
2. Check:
 - Drive chain slack ①

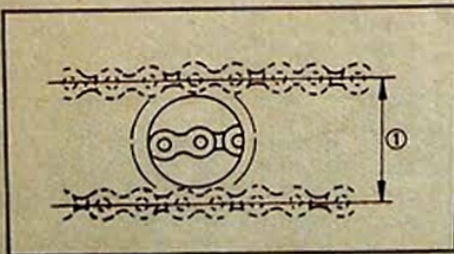

	Drive Chain Slack:
	20 ~ 30 mm

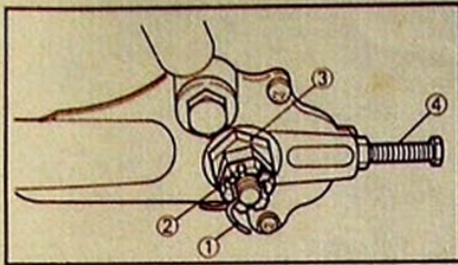

Slack Adjustment

1. Remove:
 - Cotter pin (1b)
2. Loosen:
 - Axle nut (2)
 - Sprocket shaft nut (3)
3. Adjust:
 - Slack
- (4) Adjusting bolt

NOTE: _____

Be sure that both right and left chain pullers are in the corresponding positions.

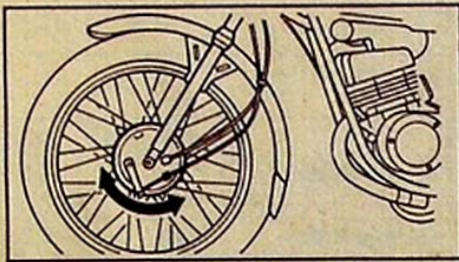

**STEERING HEAD
Checking**

1. Raise front wheel off the ground.
2. Check:
 - Steering head bearing for looseness
Gently rock fork assembly backward and forward.
 - Looseness → Adjust.

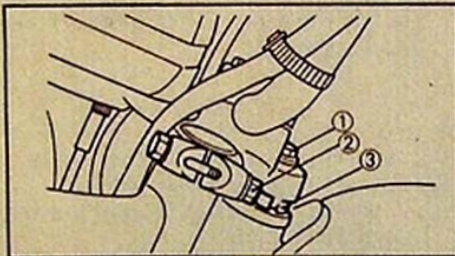

Adjustment:

1. Loosen:
 - Steering fitting bolt (1)
 - Front fork pinch bolts (2)
2. Adjust:
 - Steering head ring nut (3)
Tighten nut until steering head is tight without binding.
 - Heavy binding → Replace bearings.
3. Tighten:
 - Steering fitting bolt (1)
 - Front fork pinch bolt (2)

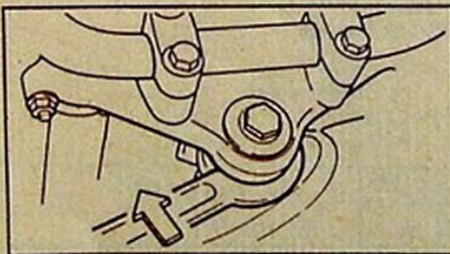

Steering Fitting Bolt (1):
3.1 m.kg, (22 ft.lb)
Front Fork Pinch Bolt (2):
2.0 m.kg, (14 ft.lb)



BATTERY

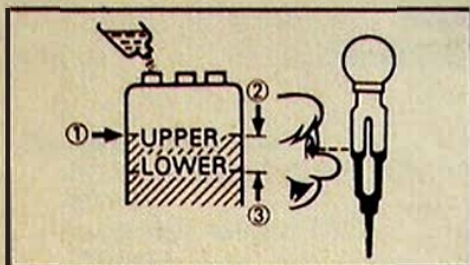

ELECTRICAL

BATTERY Fluid Level

1. Check:
 - Fluid level ①
 - Fluid level should be between upper ② and lower level line ③
 - Use only distilled water for refilling.

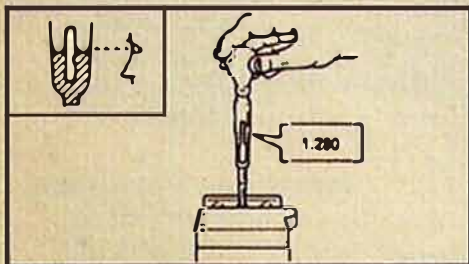

Battery Charging

1. Check:
 - Battery fluid gravity

SPECIFIC GRAVITY		
CLIMATE	INITIAL AT 20°C	FULLY CHARGED (AT 20°C)
TROPICAL (ABOVE 30°C)	1.240	1.240-1.250
COLD/TEMPERATE (BELOW 30°C)	1.260	1.260-1.270

2. If gravity is below specified, recharge battery.

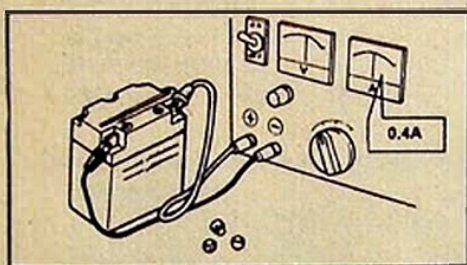

Charging Current: 0.4 A
Charging Hours: 10 hours



NOTES ON MAINTENANCE

6. Battery.

Take care so that the battery fluid does not spill on your clothes body or the motorcycle.



7. Notes on disassembly and reassembly

- a. Place all removed parts neatly and separately in groups so that they will not be confused or lost.
- b. Wash the engine and transmission parts in a detergent oil and blow them out dry with compressed air.
- c. While checking the smooth movement of parts, install them.
- d. Oil the contact surfaces of the moving parts.

8. Tightening torque.

Tighten the parts to specification by using the torque wrench.



www.yamaha-motor.com





PERIODIC MAINTENANCE/LUBRICATION

ITEM	REMARKS	Unit : Km.			
		BREAK-IN 1,000	THEREAFTER EVERY 3,000 or 3 months	6,000 or 6 months	12,000 or 12 months
Spark Plug	Check/Clean or replace	0	0		
Air filter	Clean, Replace if necessary	0	0		
Carburettor*	Check/Adjust/idle speed, starter operation	0		0	
Fuel line	Check fuel hose for cracks or damage	0	0		
Transmission oil	Replace (Warm engine before draining)	REPLACE	CHECK	REPLACE	
Autolube pump	Check/Adjust*/Air bleeding*	0	0		
Brake*	Check/operation	0	0		
Clutch*	Check operation	0	0	0	
Rear arm pivot*	Check rear arm assembly for looseness. replace Silent block bushes 24,000 or 24 months.	0		0	
Wheels*	Check balance/damage/runout/spoke tightness.	0		0	
Wheel bearings*	Check bearings assembly for looseness/damage. Replace if damaged.			0	REPACK** GREASE
Steering bearing*	Check bearings assembly for looseness.	0			REPACK** GREASE
Front Fork*	Check operation/oil leakage ††	CHECK		CHECK	REPLACE OIL
Rear Shock absorber	Check operation/oil leakage		0		
Drive Chain	Clean/lube/align* Check tension every 1000 kms./align*		0		
Fittings/Fasteners*	Check all chassis/engine/Cyl./Cyl. Head	0	0		
Battery*	— Check specific gravity ‡‡ — Check breather pipe for proper operation. — Check electrolyte level/add distilled water every 15 days.	0	0		
Decarbonising*	Remove carbon from (Cyl./Cyl. Head/ Piston Assy/Muffler)			0	
Ignition Timing*	Check				0
Fuel Strainer	Clean	0	0		
Fuel Tank/Fuel Cock*	Clean				0
Tyres	Check		0		

* It is recommended that these items be serviced by Yamaha dealer.

** Medium weight wheel bearing grease.

†† Use 175 ± 3cc 'Servo Teleshocab' oil of M/s Indian Oil.

‡‡ Battery Specific gravity — 1240/20°C



INSP
ADJ

2

PERIODIC MAINTENANCE/LUBRICATION

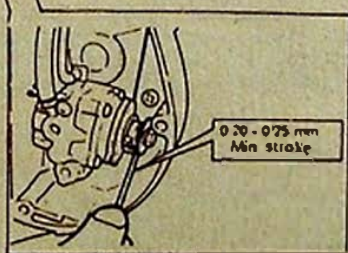
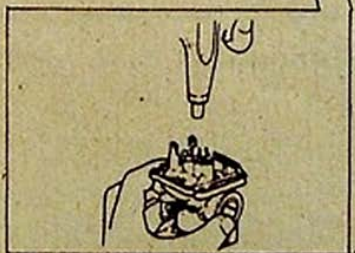
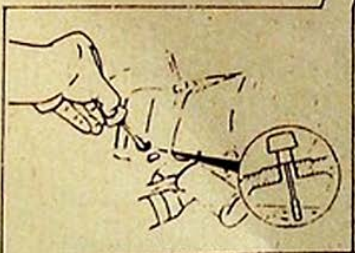
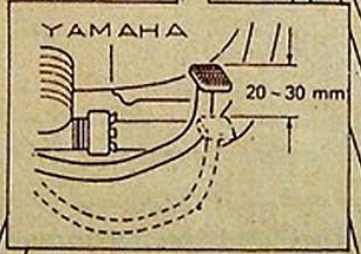
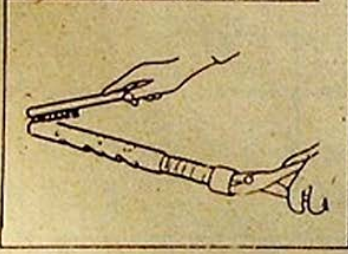
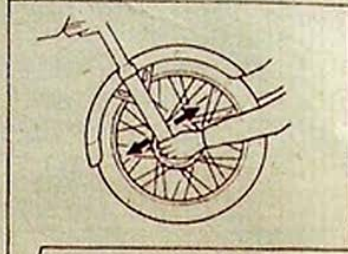
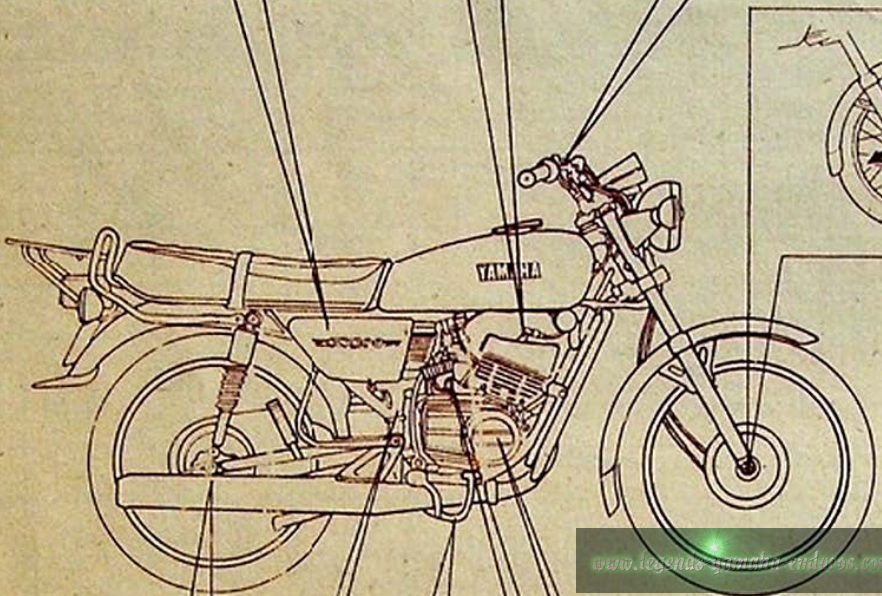
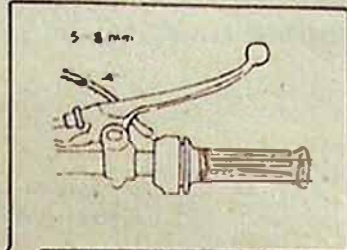
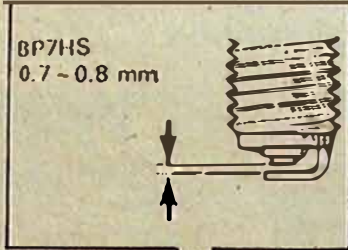

www.legendas-gambar-indonesia.com



PERIODIC MAINTENANCE/LUBRICATION

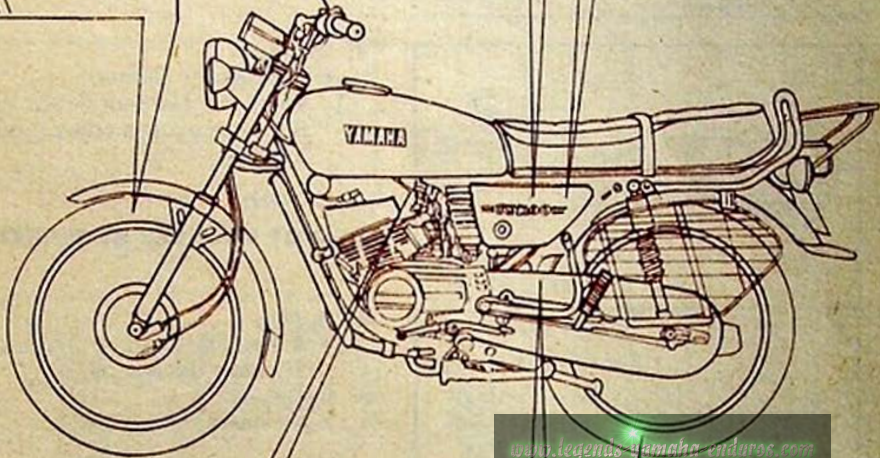
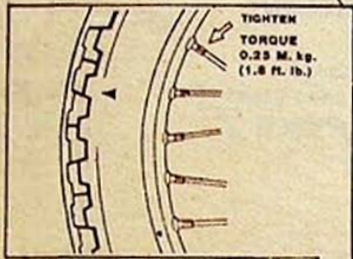
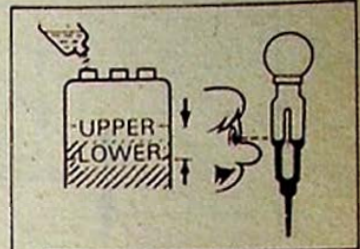
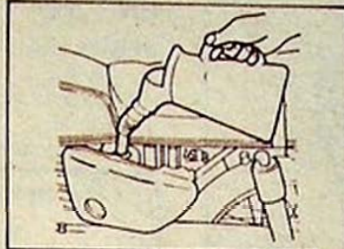
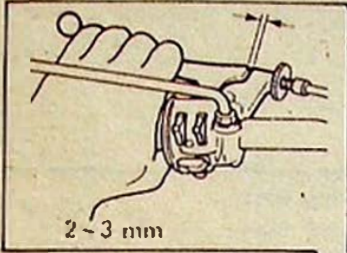

www.legendaryamahaenduros.com

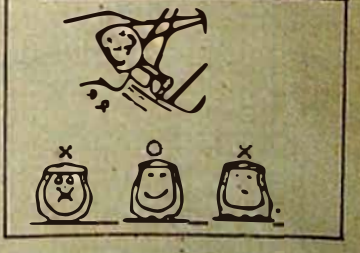
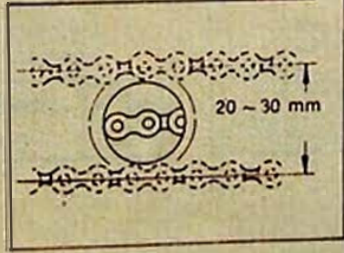
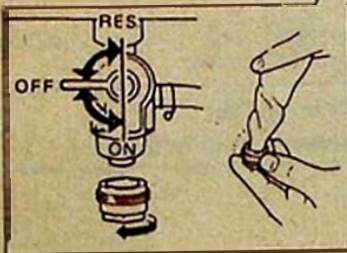

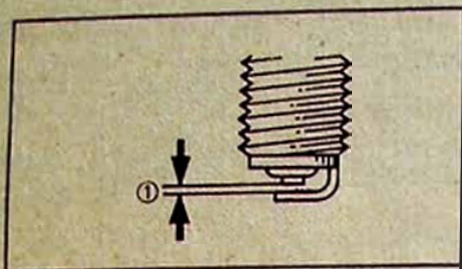

ENGINE

SPARK PLUG

- Clean:
 - Spark plug
- Adjust:
 - Plug gap ①



Spark Plug Gap:
0.7~0.8 mm

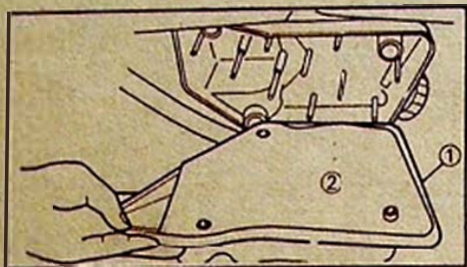

AIR CLEANER ELEMENT

- Remove:
 - Right side cover
 - Air cleaner case cover ①
 - Air cleaner element ②
- Clean:
 - Air cleaner element

Wash the element in solvent.
Squeeze excess solvent out of the element and dry.

CAUTION:

DO NOT SQUEEZE BY TWISTING

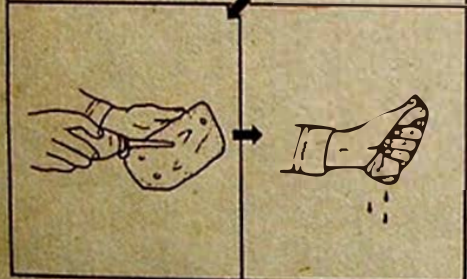
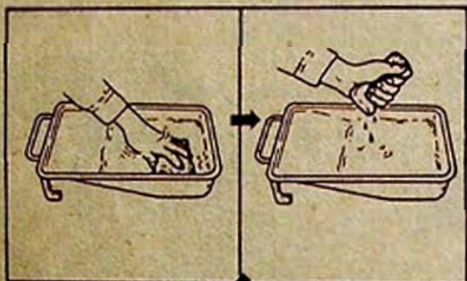

- Apply:
 - A small quantity of 2-stroke engine oil.
Squeeze excess oil.
- Install:
 - Air cleaner element



TRANSMISSION OIL

Checking

- Check:
 - Oil level

Maintain transmission oil level always between MAX and MIN lines.



Recommended Oil:
Servo Super 30 or Equivalent

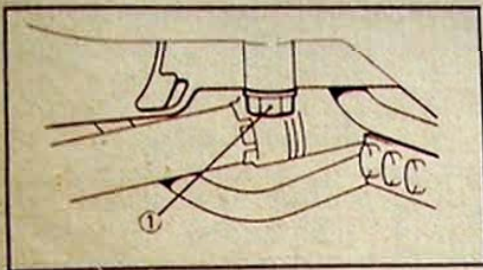

Replacement

1. Start the engine and let it warm up.
2. Remove:
 - Drain bolt ①
 Drain oil after warming up engine.
3. Install:
 - Drain bolt ①



Drain Bolt:

2.0 m.kg. (14 ft. lb)

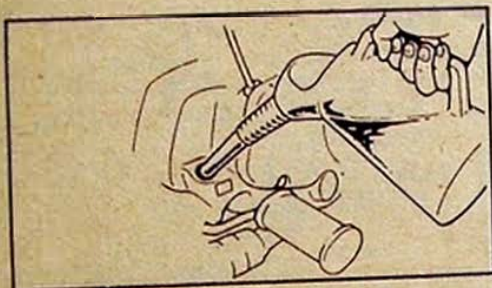

3. Fill:
 - Transmission oil



0.65 L

4. Check:
 - Oil level

**AUTOLUBE PUMP
Cable Adjustment**

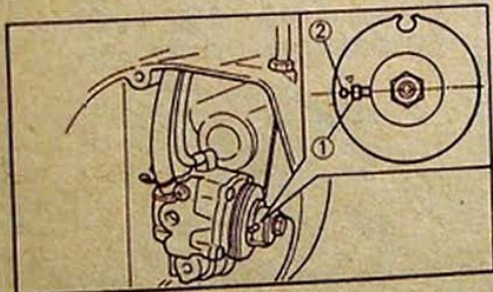

1. Check to see if pump guide pin ① is aligned with mark on adjusting pulley ②

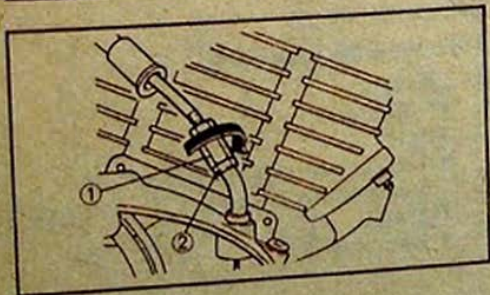

2. If not aligned, align by turning adjuster ① in or out.

② Locknut

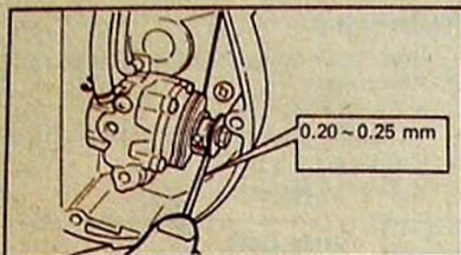

AUTOLUBE PUMP/CARBURETTOR

**Minimum pump stroke adjustment**

1. Rotate engine so that adjust plate moves out to limit.
2. Measure:
 - Minimum pump stroke

**Minimum Pump Stroke:**

0.20~0.25 mm

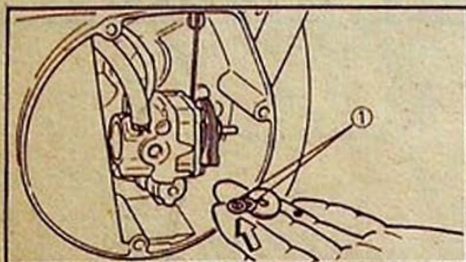

3. If clearance is not correct, adjust by the shim ①

Adding of shim will increase the stroke and vice versa.

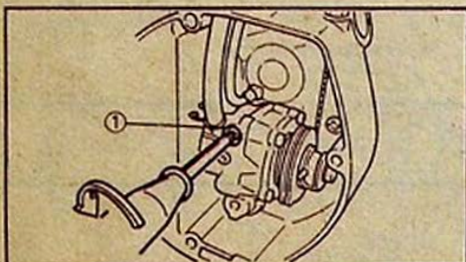
**Air Bleeding**

1. Remove:
 - Pump bleed screw ①
 - Keep oil running out until air bubbles disappear.
2. Install:
 - Bleed screw ①

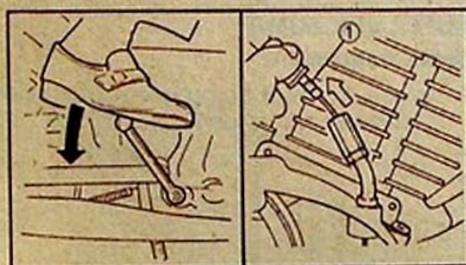

3. Start the engine and pull the pump wire ① all the way for some minutes.

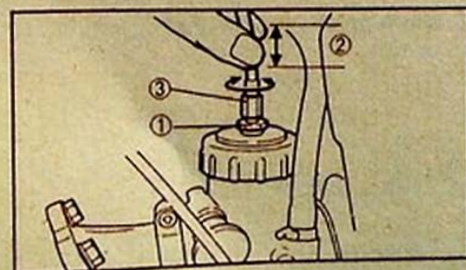
**CARBURETTOR****Throttle Grip Free Play**

1. Loosen:
 - Locknut ①
2. Adjust:
 - Cable free play ② 1 ~ 2 mm
 - Turn cable adjuster ③ In or Out.
3. Tighten:
 - Locknut ①



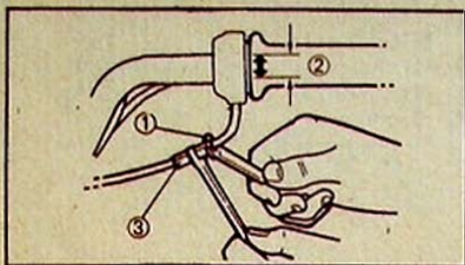

CARBURETTOR/CLUTCH

**Throttle Cable Free Play**

- Loosen:
 - Loosen (1)
- Adjust:
 - Cable free play (2) 5~8 mm
 - Turn cable adjuster (3) in or out.
- Tighten:
 - Locknut (1)

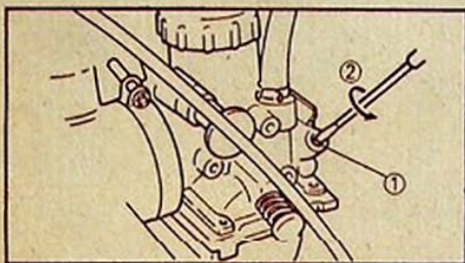
**Idle Speed**

- Turn pilot air screw (1) in until lightly seated.
- Back out by specified numbers of turns.

**Pilot Air Screw Turn Out:**

1-1/4 ± 1/2

(2) 1-1/4 ± 1/2

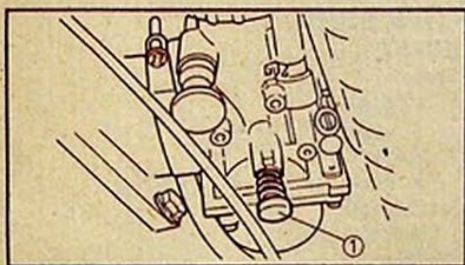

- Start the engine and let it warm up.
- Turn the throttle stop screw (1) in or out until idle speed is at specified rpm.

**Engine Idle Speed:**

1,200 ± 50 rpm

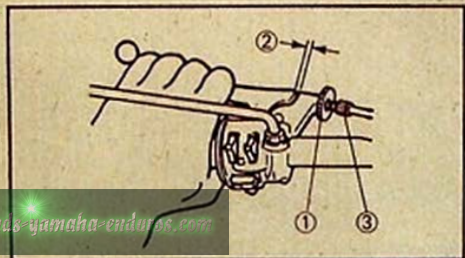
**CLUTCH
Cable Adjustment**

- Loosen:
 - Locknut (1)
- Adjust:
 - Cable free play (2) 2~3 mm
 - Turn cable adjuster (3) in or out.
- Tighten:
 - Locknut (1)

Mechanism Adjustment

- Remove:
 - Left crankcase cover (1)
- Position the push lever (2) by the cable adjuster
- Install:
 - Left crankcase cover (1)

(3) 75 mm

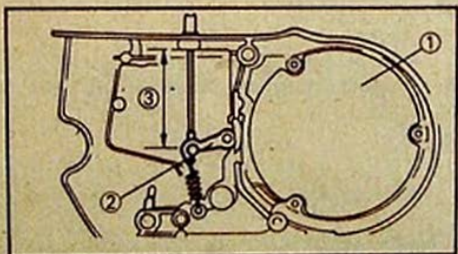



CHAPTER 3 ENGINE OVERHAUL

ENGINE DISASSEMBLY	3-1
CYLINDER HEAD AND CYLINDER	3-1
PISTON	3-1
FLYWHEEL MAGNETO	3-1
CLUTCH	3-2
KICK STARTER	3-2
SHIFT SHAFT	3-3
CRANKCASE	3-3
TRANSMISSION AND SHIFTER	3-3
CRANKSHAFT	3-4
INSPECTION AND REPAIR	3-5
CYLINDER HEAD	3-5
CYLINDER	3-5
PISTON	3-6
PISTON RING	3-7
PISTON PIN AND SMALL END BEARING	3-7
CLUTCH	3-8
KICK STARTER	3-9
CRANKSHAFT	3-9
TRANSMISSION	3-10
BEARINGS AND OIL SEALS	3-12
ENGINE ASSEMBLY AND ADJUSTMENT	3-13
CRANKSHAFT	3-13
TRANSMISSION AND SHIFTER	3-14
CRANKCASE ASSEMBLY	3-15
SHIFT SHAFT	3-16
KICK STARTER	3-17
CLUTCH	3-18
PRIMARY DRIVE GEAR	3-19
FLYWHEEL MAGNETO	3-19
PISTON	3-20
CYLINDER	3-21
CYLINDER HEAD	3-21
ENGINE MOUNTING	3-21



ENGINE DISASSEMBLY CYLINDER HEAD AND CYLINDER

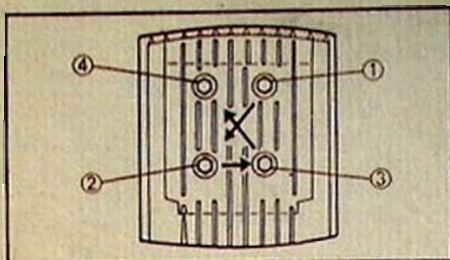

1. Remove:
 - Cylinder head nuts
 - Cylinder head
 - Cylinder nuts
 - Cylinder

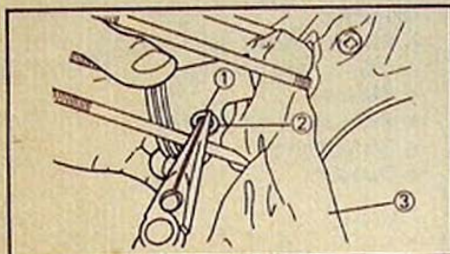

PISTON

1. Remove:
 - Piston pin clip (1)
 - Piston pin (2)
 - Piston
 - Piston rings

NOTE:

Before removing the piston pin clip, cover the crankcase with a clean rag (3)

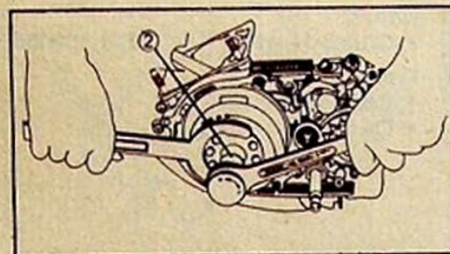

FLYWHEEL MAGNETO

1. Remove:
 - Crankcase cover (Left)
2. Attach:
 - Flywheel Holding Tool ESM-100000201 (1)
3. Remove:
 - Flywheel holding nut (2)
 - Lock washer
 - Washer

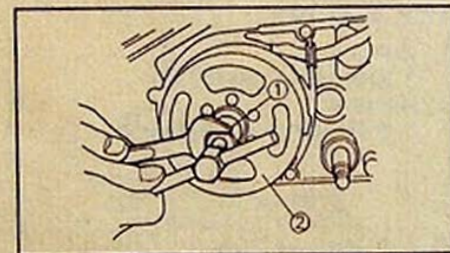

4. Attach:
 - Flywheel Puller ESM-100000202 (1)
(Left-Hand-Threads)
5. Remove:
 - Flywheel (2)
 - Woodruff key

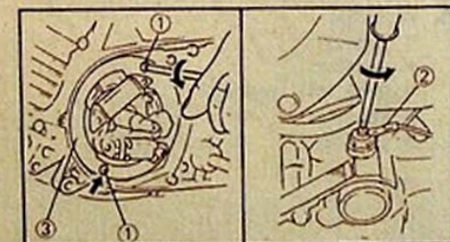

6. Remove:
 - Stator holding screws (1)
 - Neutral switch lead wire (2)
 - Stator assembly (3)

INSPECTION AND REPAIR

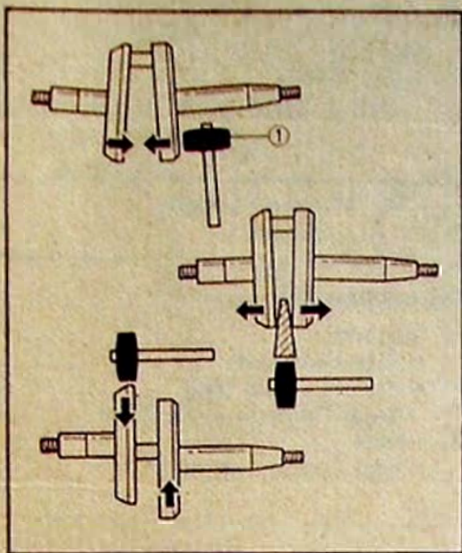

3. Repair:
- Crankshaft
Using copper hammer ①

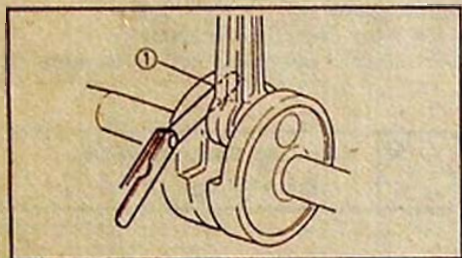

4. Measure:
- Big end side clearance
Use feeler gauge ①
Out of specification → Repair or replace.

Big End Side Clearance:
0.2~0.7 mm

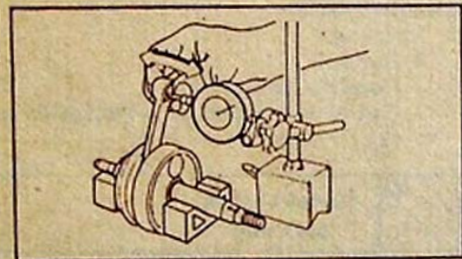

5. Measure:
- Small end free play
Out of specification → Replace.

Small End Free Play:
1.5~2.0 mm

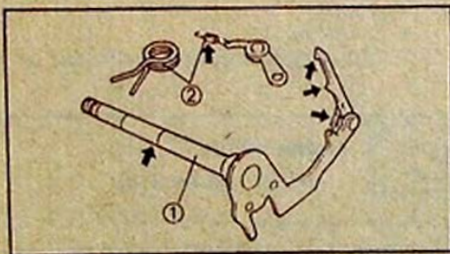

TRANSMISSION

Shift Shaft

1. Inspect:
- Shift shaft ①
 - Springs ②
Wear/Bend → Replace.



INSPECTION AND REPAIR

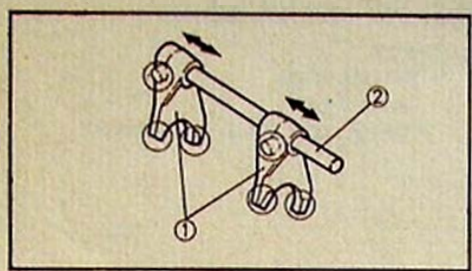

Shift Fork

1. Inspect:
 - Shift forks ① (on the gear and shift cam contact surface)
 - Shift fork guide bars ②
Wear/Chaling/Bends/Damage → Replace.
2. Check:
 - Shift fork movement (on shift cam)
Unsmooth operation → Replace fork and/or guide bar.

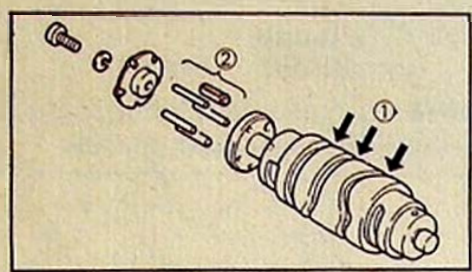

Shift Cam

1. Inspect:
 - Shift cam grooves ①
Wear/Damage/Scratches → Replace.
 - Shift cam pins ②
Wear/Damage → Replace.

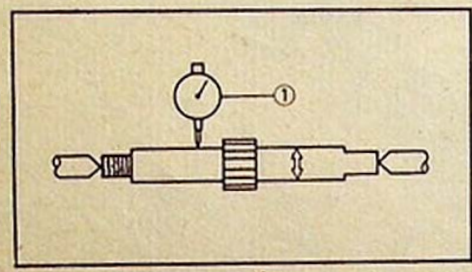

Main Axle and Drive Axle

1. Measure:
 - Axle runout
Use centering device and Dial Gauge ①
Out of specification → Replace.

	Runout Limit: 0.1 mm
--	-------------------------

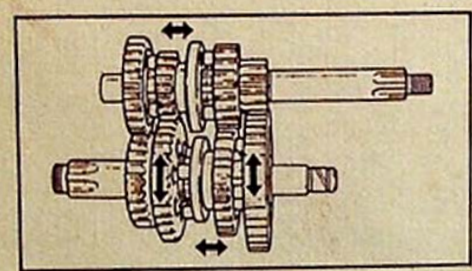

Gears

1. Inspect:
 - Gears
Damage/Wear → Replace.
2. Check:
 - Gear movement
Unsmooth operation → Replace.

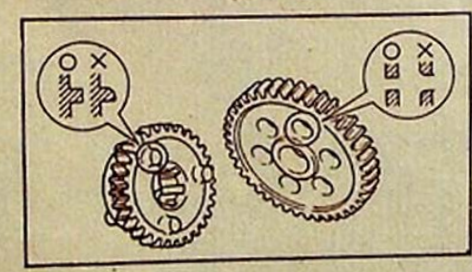

3. Inspect:
 - Matching dogs
Cracks/Wear/Damage → Replace.



INSPECTION AND REPAIR

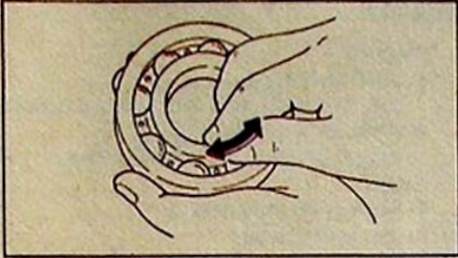

BEARING AND OIL SEALS

1. Check:

- All bearings
(with finger)
Rough spot/Play → Replace.

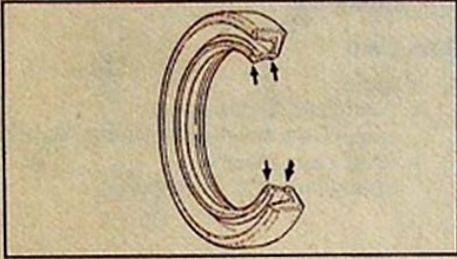

2. Inspect:

- All oil seal lips
Damage/Wear → Replace.

NOTE: _____

Always replace crankshaft oil seals.



**ENGINE ASSEMBLY AND
ADJUSTMENT****NOTE:**

Before assembling the engine, thoroughly wash the parts in mild solvent.

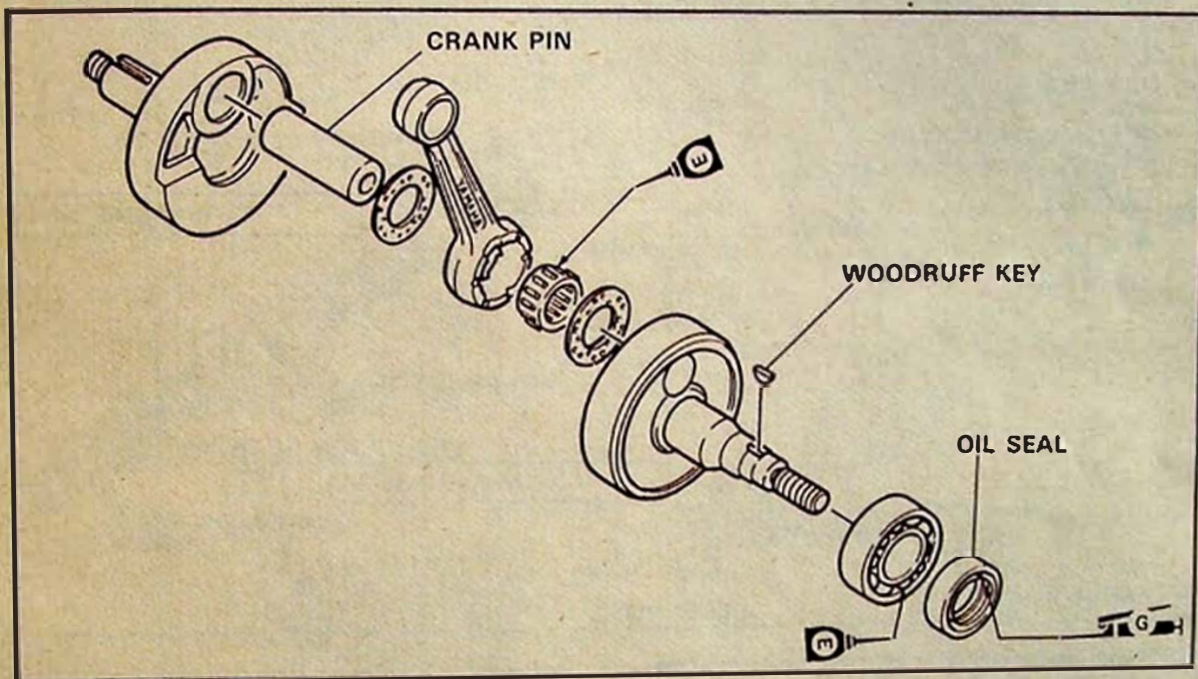
CRANKSHAFT**1. Attach:**

- Crankshaft Installing Tool
ESM-100000286 ①
(to the left side crankcase)

2. Tighten:

- Nut of the installing tool
Hold the connecting rod at top dead center.

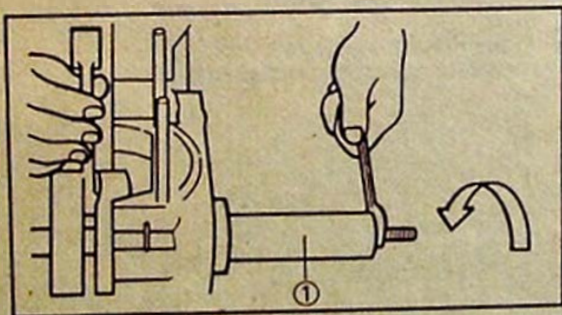

TRANSMISSION AND SHIFTER

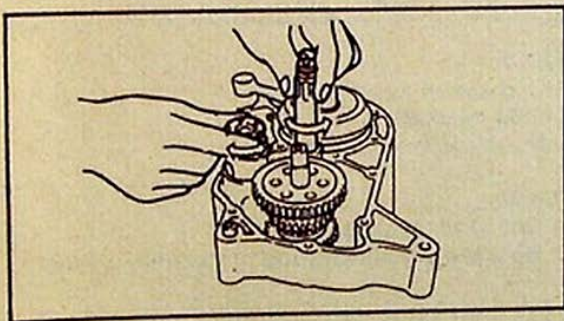
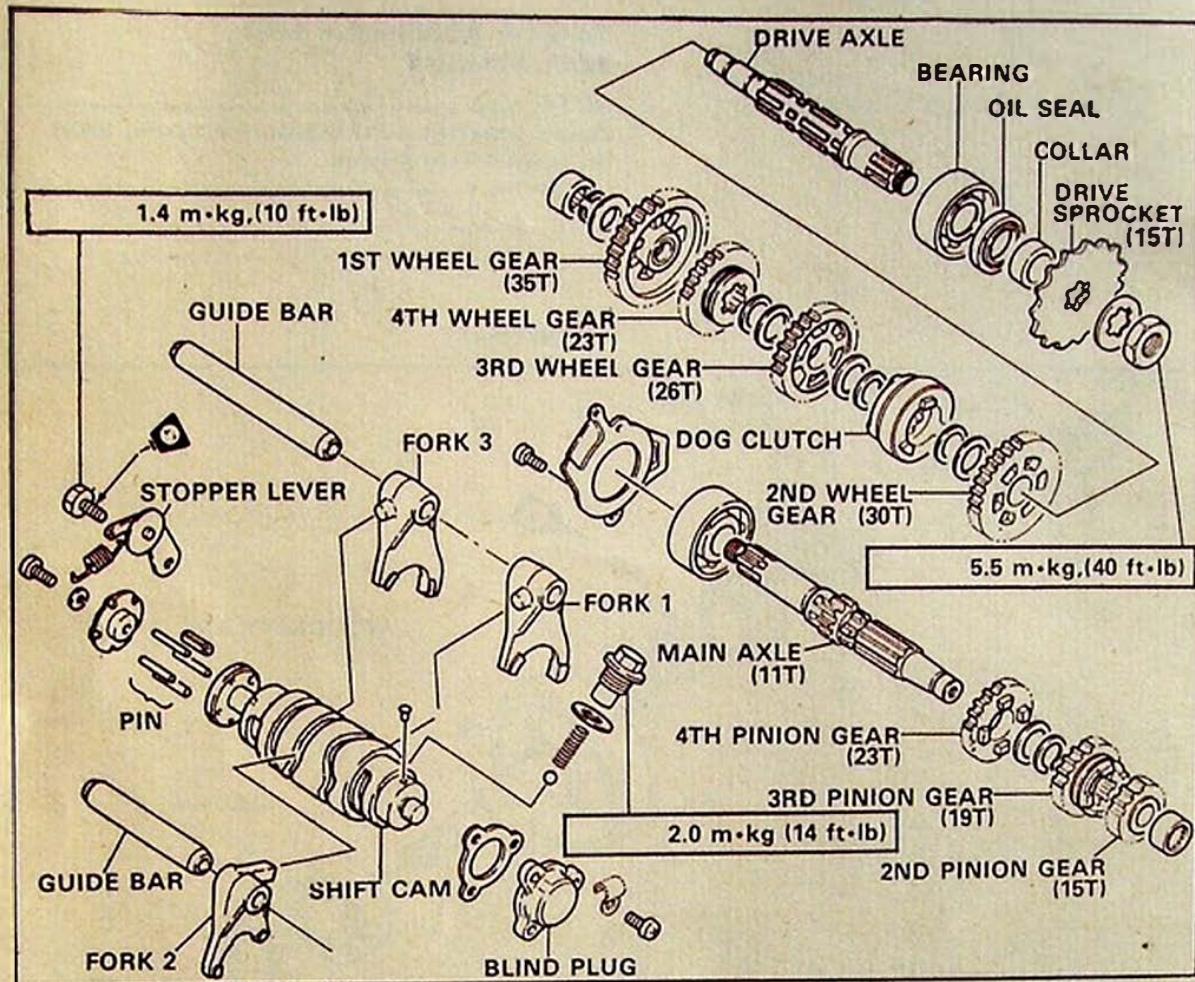

1. Install:
 - Transmission assembly
2. Check:
 - Transmission operation
 Incorrect operation → Reassembly.



CRANKCASE ASSEMBLY

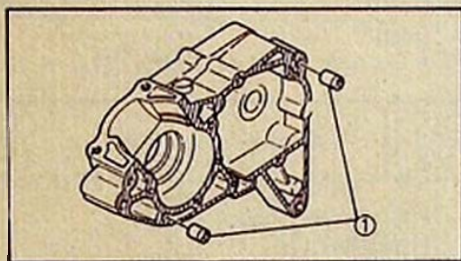
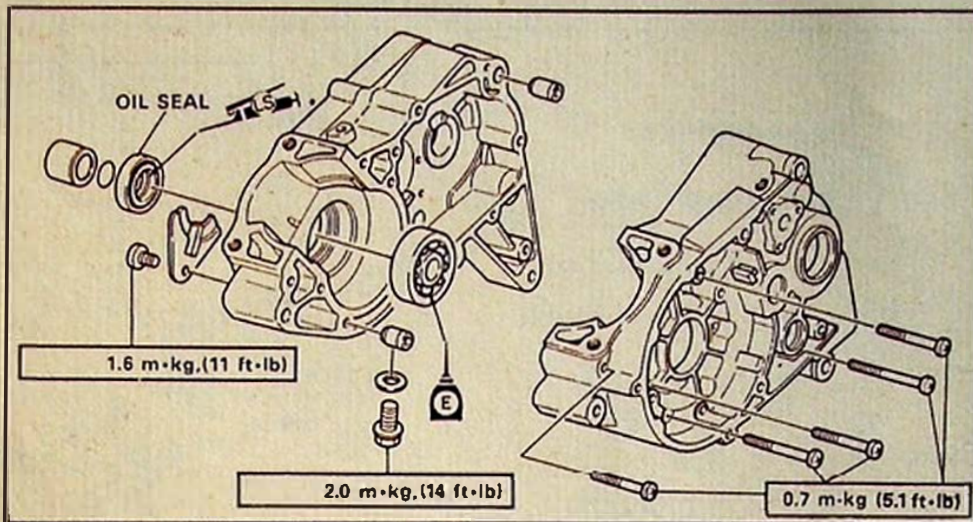

1. Apply:
 - Yamaha Bond No.4
(to both crankcase mating surfaces.)

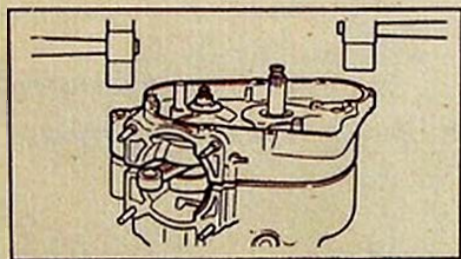

2. Install:
 - Dowel knock pins ①

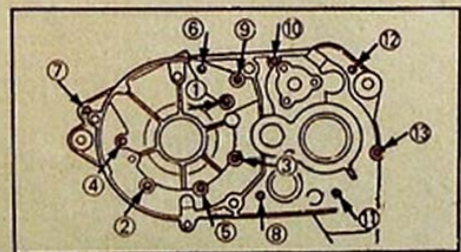

3. Install:
 - Right crankcase half
(Tap with plastic hammer)

4. Tighten:
 - Crankcase tightening screws
Tighten the screws in showing sequence and in two steps.



0.7 m.kg. (5.1 ft.lb)

SHIFT SHAFT

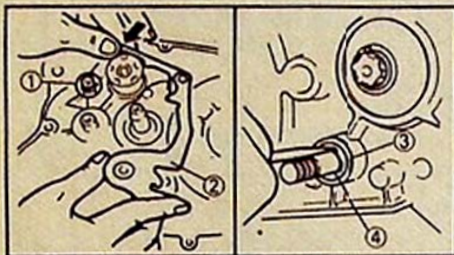
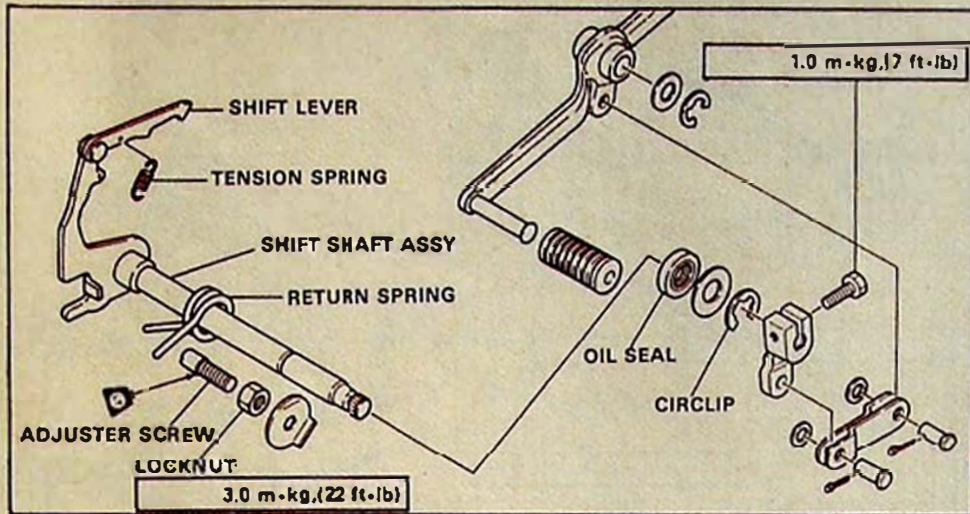

1. Install:
 - Stopper lever assembly ①

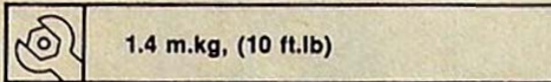

- Shift shaft assembly ②
- Washer ③
- Circlip ④

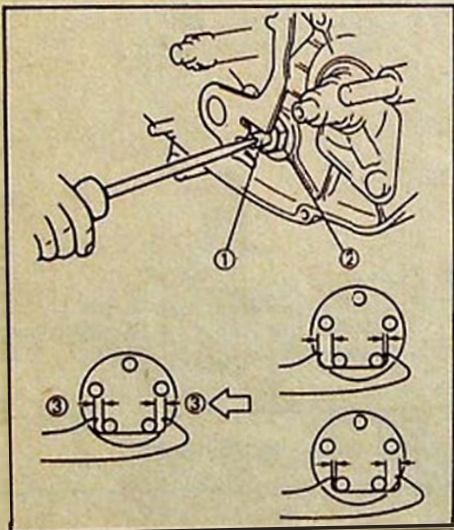

2. Adjust:
 - Shift lever position (by adjuster screw ① and locknut ②)
3. Gap ③ To be equal on both sides.



KICK STARTER

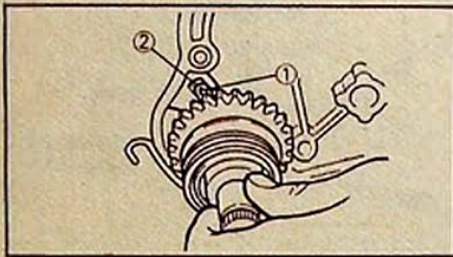
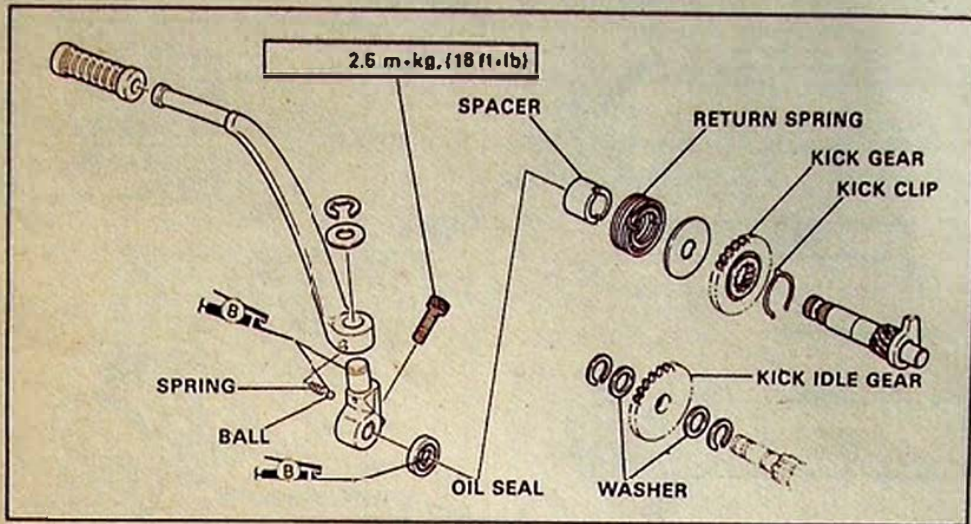

1. Install:
 - Kick starter assembly
2. Position the kick clip ① in groove ② of the crankcase as shown.

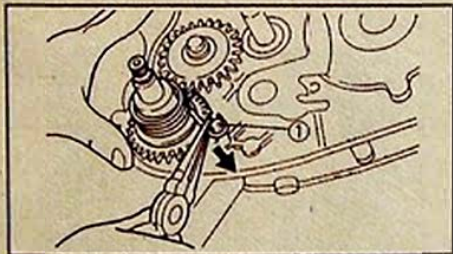

3. Hook:
 - Return spring ①

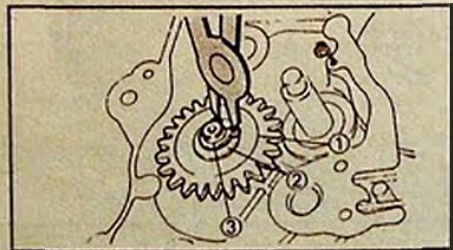

4. Install:
 - Circlip
 - Washer
 - Kick idle gear ①
 - Washer ②
 - Circlip ③

CLUTCH

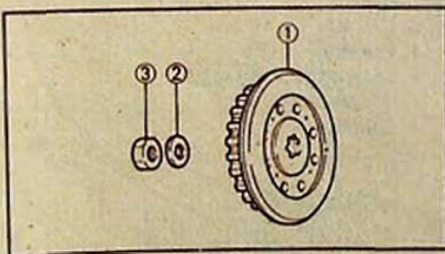
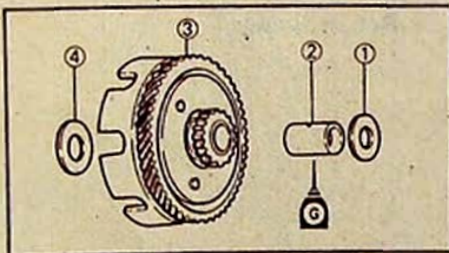
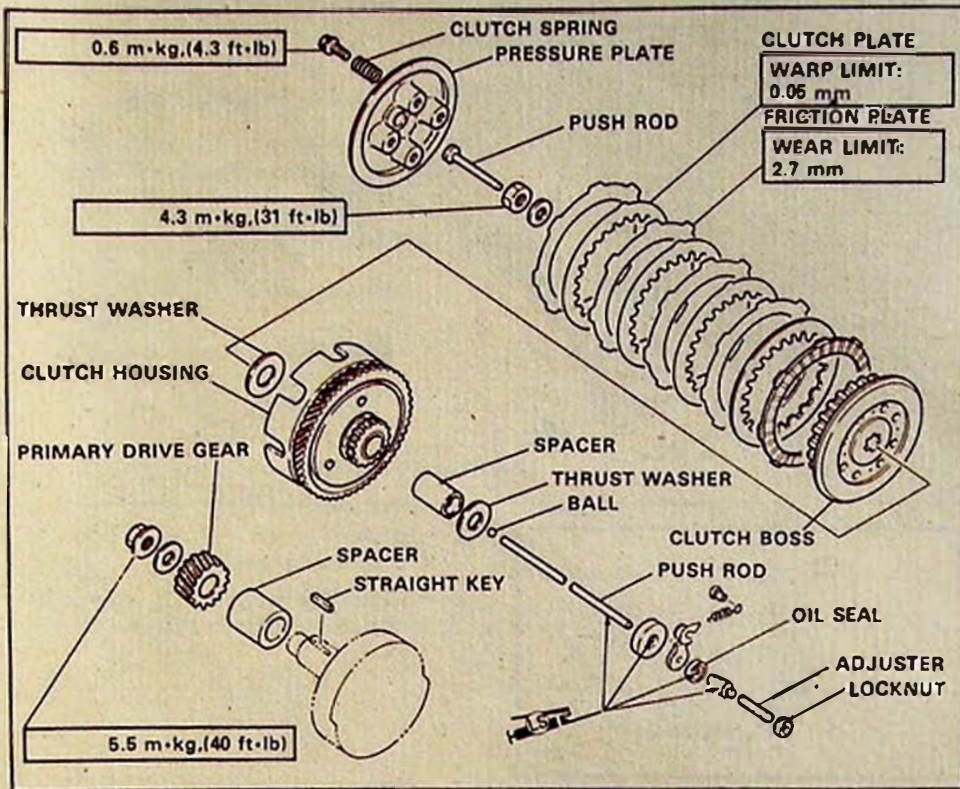

Clutch Boss:
4.3 m•kg. (31 ft•lb)

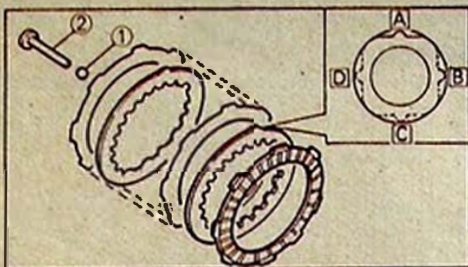

3. Install:
- Friction plates
 - Clutch plates
 - Ball (1)
 - Push rod (2)

CAUTION: _____
 The clutch plates must be so installed that their cutaways do not overlap each other.

A : 1st B : 2nd C : 3rd D : 4th

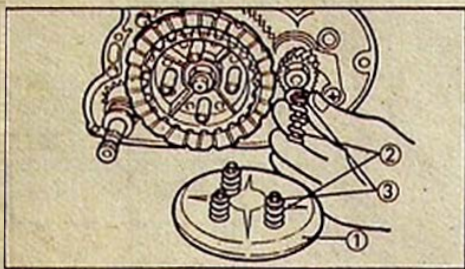

4. Install:
- Pressure plate (1)
 - Springs (2)
 - Bolts (3)



Clutch Spring Nut:
 0.6 m.kg. (4.3 ft.lb)

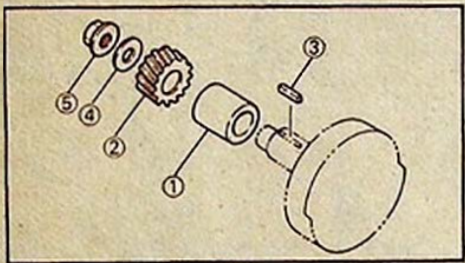

PRIMARY DRIVE GEAR

1. Install:
- Spacer (1)
 - Primary drive gear (2)
 - Straight key (3)
 - Washer (4)
 - Nut (5)



Primary Drive Gear:
 5.5 m.kg (40 ft.lb)



FLYWHEEL MAGNETO

1. Install:
- Stator assembly (1)



Stator:
 0.7 m.kg. (5.1 ft.lb)

2. Connect:
- Neutral switch led wire (2)

3. Install:
- Woodruff key (1)
 - Flywheel (2)



Flywheel Magneto:
 7.0m.kg. (50 ft.lb)

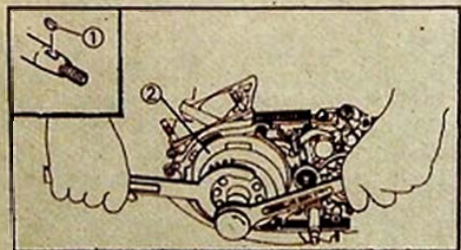

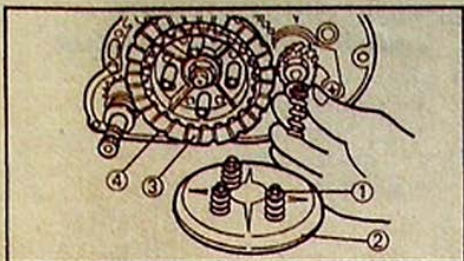

CLUTCH

1. Remove:
 - Crankcase cover (Right)
 - Clutch spring bolts (1)
 - Clutch springs
 - Pressure plate (2)
 - Friction plates (3)
 - Clutch plate (4)

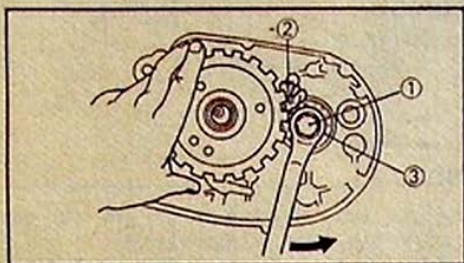

2. Remove:
 - Primary drive gear nut (1)
 - Use folded rag (2)
 - Washer
 - Primary drive gear (3)
 - Straight key
 - Spacer

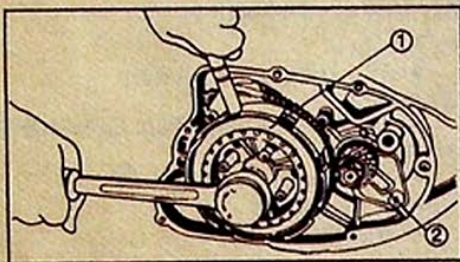

3. Attach:
 - Clutch Holding Tool ESM-100000233 (1)
4. Remove:
 - Clutch assembly (2)
 - Oil seal retainer (2)

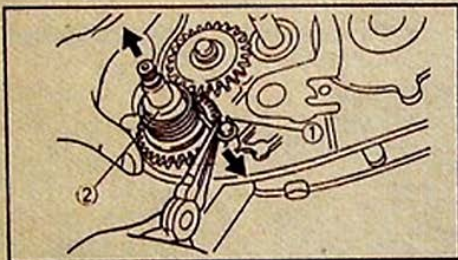

KICK STARTER

1. Unhook:
 - Kick return spring (1)
2. Remove:
 - Kick starter assembly (2)

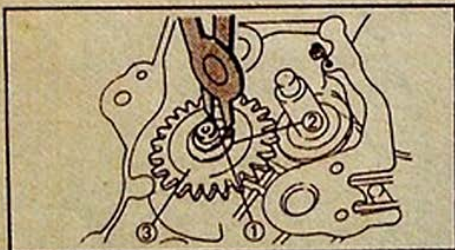

3. Remove:
 - Circlip (1)
 - Washer (2)
 - Kick idle gear (3)
 - Washer
 - Circlip



ENGINE ASSEMBLY AND ADJUSTMENT

PISTON

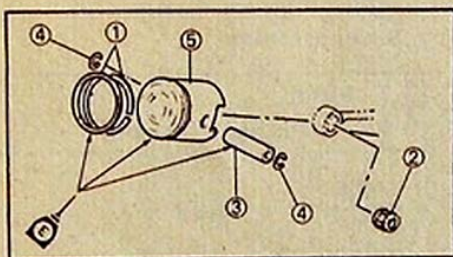
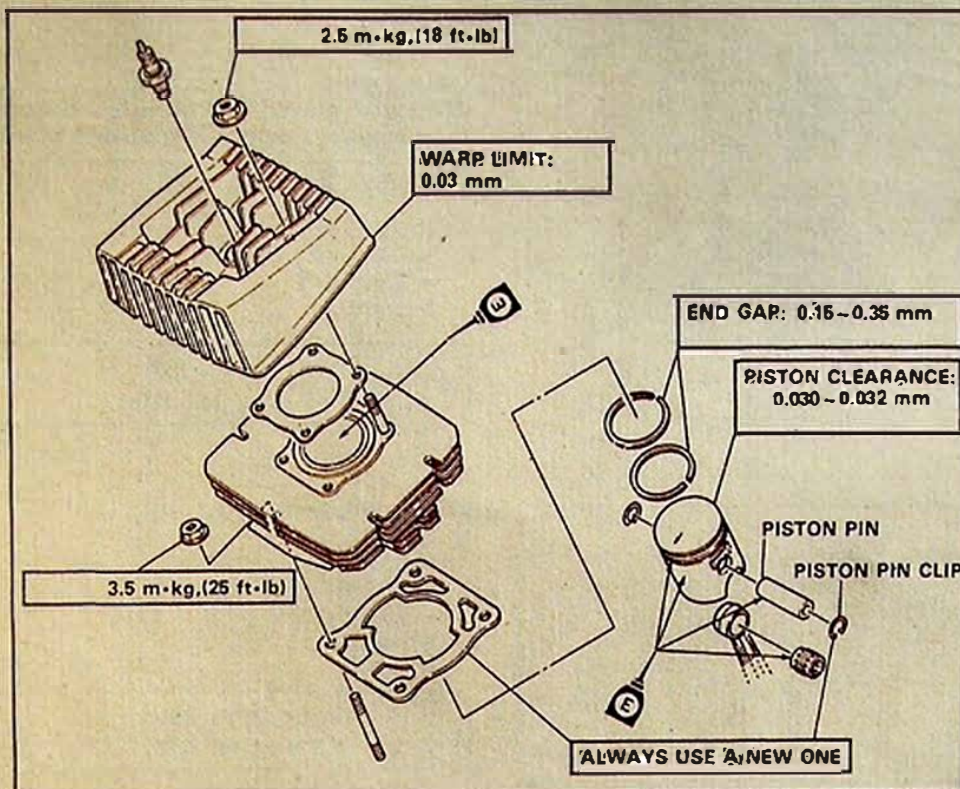

1. Install:

- Piston rings ①
- Small end bearing ②
- Piston pin ③
- Piston pin clips (New) ④
- Piston ⑤

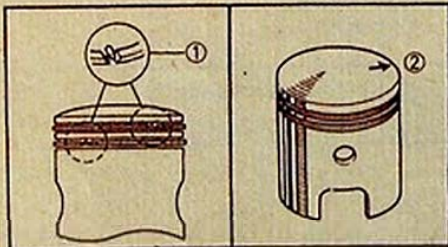

NOTE:

- Make sure ring ends ① are properly fitted around ring locating pins in piston grooves.
- The arrow ② on piston dome must face exhaust side.



ENGINE ASSEMBLY AND ADJUSTMENT

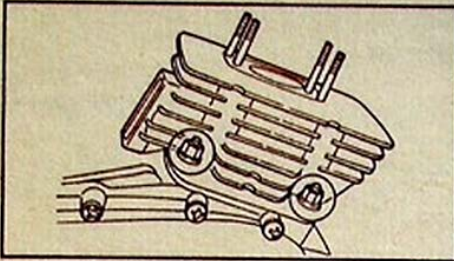

CYLINDER

1. Install
 - Gasket (New)
 - Cylinder



Cylinder:

3.5 m.kg, (25 ft.lb)

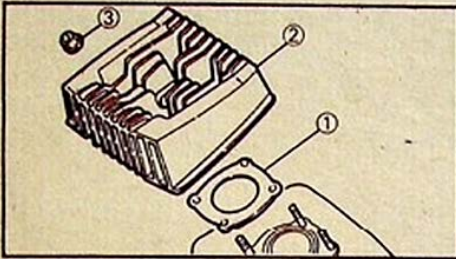

CYLINDER HEAD

1. Install:
 - Head gasket ①
 - Cylinder head ②
 - Nuts ③



Cylinder Head:

2.5 m.kg, (18 ft.lb)

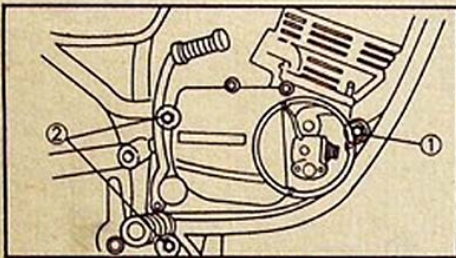

ENGINE MOUNTING



Engine Mount Bolts:

- ① 3.0 m.kg, (22 ft.lb)
- ② 6.0 m.kg, (43 ft.lb)

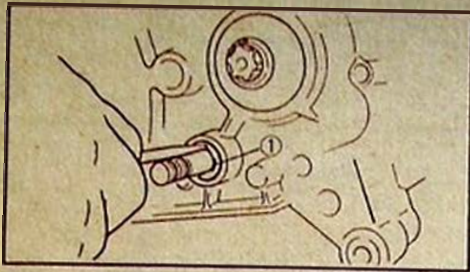

SHIFT SHAFT

1. Remove:
 - Circlip (1) (on left side)

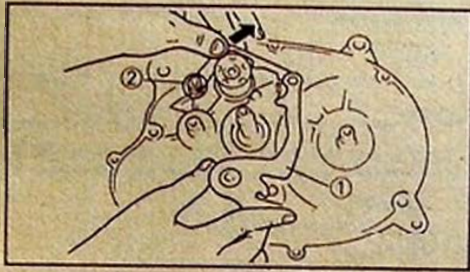

2. Remove:
 - Shift shaft assembly (1)
 - Stopper lever assembly (2)

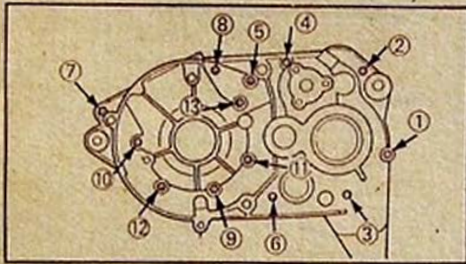

CRANKCASE

1. Remove:
 - Crankcase tightening screws

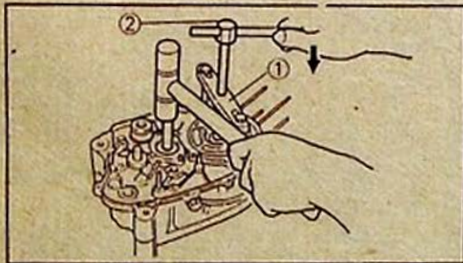

2. Attach:
 - Crankcase separating tool ESM-100000265 (1) (to the right side crankcase)

NOTE: _____
 Make sure the tool body is parallel with the case.

3. Tighten:
 - Securing bolt (2)

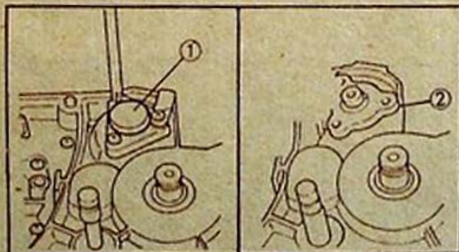

TRANSMISSION AND SHIFTER

1. Remove:
 - Shift cam blind plug (1)
 - Gasket (2)

ENGINE DISASSEMBLY

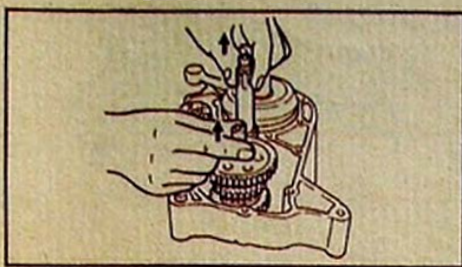

2. Remove:
 - Transmission assembly

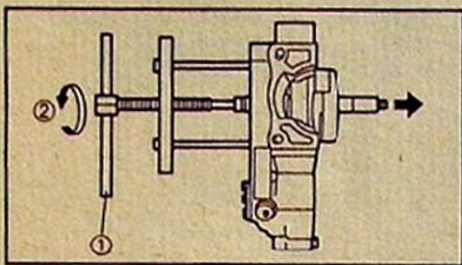

CRANKSHAFT

1. Attach:
 - Crankcase separating tool ESM-100000265 (1)

NOTE:

Make sure the tool body is parallel with the case.

2. Tighten:
 - Securing bolt (2)
3. Remove:
 - Crankshaft Assy.

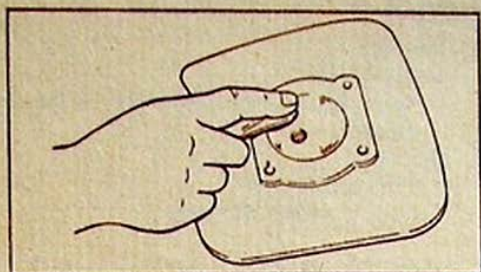

INSPECTION AND REPAIR

CYLINDER HEAD

1. Remove:
 - Carbon deposit
Use rounded scraper.

NOTE: _____

Do not use a sharp instrument and avoid damaging or scratching.

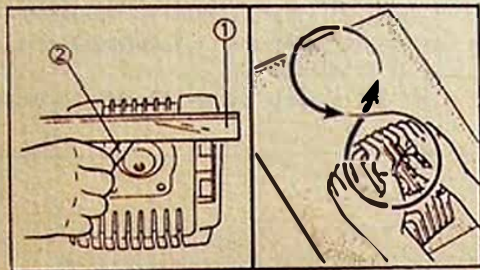

2. Measure:
 - Cylinder head warpage
Out of specification → Resurface or replace.

Less than 0.03 mm

- ① Straight edge
- ② Thickness gauge

CYLINDER

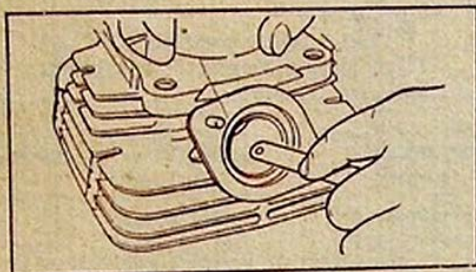

1. Remove:
 - Carbon deposit
Use rounded scraper.

NOTE: _____

Do not use a sharp instrument and avoid damage or scratching.

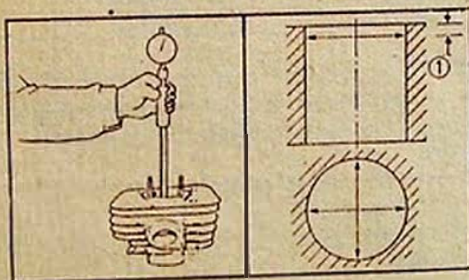

2. Inspect
 - Cylinder wall
Wear/Scratches → Rebore or replace.

3. Measure
 - Cylinder bore "C"
Use Cylinder Bore Gauge.
Out of specification → Rebore.

① 10

	Standard	Wear Limit
Cylinder Bore C:	50.00 50.02 mm	50.1 mm
Cylinder Taper T:	—	0.05 mm

C = Cylinder bore
T = (Maximum C)-(Minimum C)

INSPECTION AND REPAIR

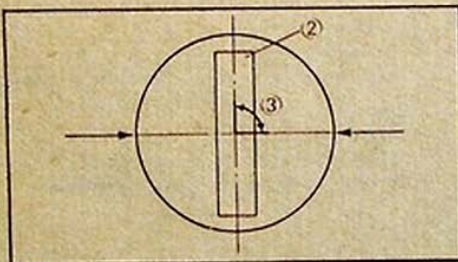
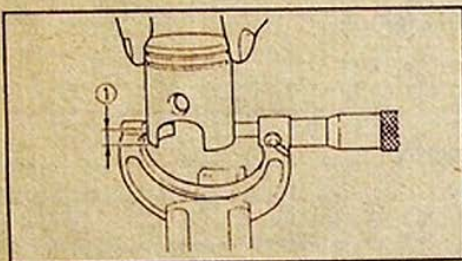
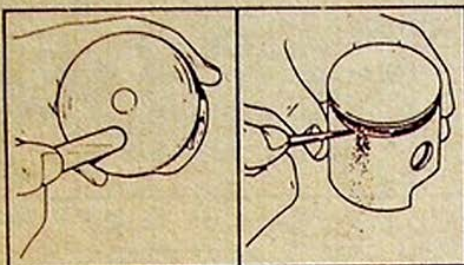
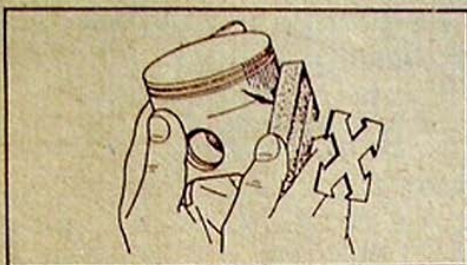

PISTON

1. Inspect:
 - Piston wall
Wear/Scratches/Damages → Repair or replace.
2. Remove:
 - Carbon deposit
Use rounded scraper.

NOTE:

- Do not use a sharp instrument and avoid damaging or scratching.
- After correcting, clean the piston with a clean cloth.

3. Measure:

- Piston outside diameter "P"
Out of specification → Replace.

	Size A
Standard <Limit>	49.966 — 49.986 mm 49.90 mm
Overize 1	50.25 mm
Overize 2	50.50 mm
Overize 3	50.75 mm
Overize 4	51.00 mm

NOTE:

- Measurement should be made at a point 10mm above the bottom edge of the piston skirt.

- ① 10 mm
- ② Piston pin
- ③ 90°

4. • Piston clearance
Out of specification → Rebore cylinder or replace piston.



Piston Clearance = Minimum
Cylinder Bore 'C' — Piston dia 'P'
0.030~0.038 mm



C = Maximum cylinder bore
P = Piston outside diameter

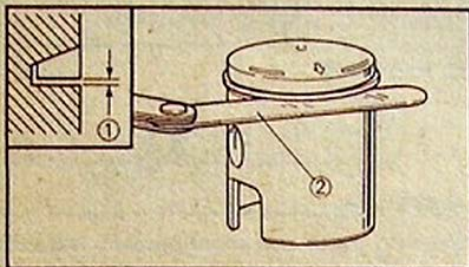

PISTON RING

1. Measure:
 - Side clearance (1)
 - Use a feeler gauge (2)
 - Out of specification → Replace piston and/or rings.

	Side Clearance: 0.02 — 0.06 mm
--	--

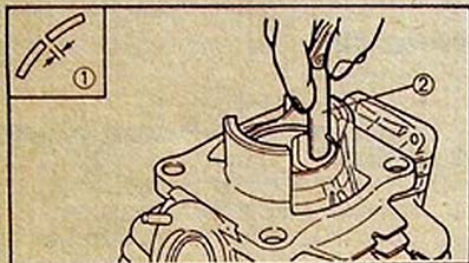

2. Measure:
 - End gap: (1)
 - Use feeler gauge (2)
 - Out of specification → Replace rings as a set.

	End Gap: (Installed)	Standard	Limit
		0.15~0.35 mm	0.6 mm

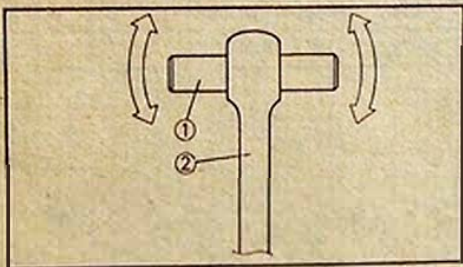

PISTON PIN AND SMALL END BEARING

1. Lubricate:
 - Piston pin (1) and bearing
2. Install:
 - Piston pin and bearing (into small end of connecting rod (2))
3. Check:
 - Free play
 - Free play → Inspect connecting rod for wear.
 - Wear → inspect connecting rod and piston pin.

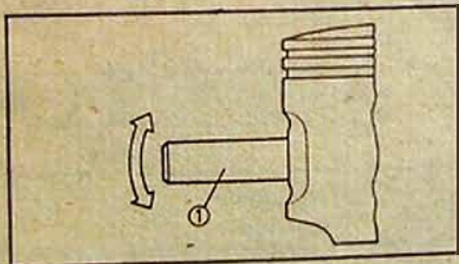

4. Install:
 - Piston pin (1) (into piston)
5. Check:
 - Free play
 - Free play → Replace piston pin and/or piston.

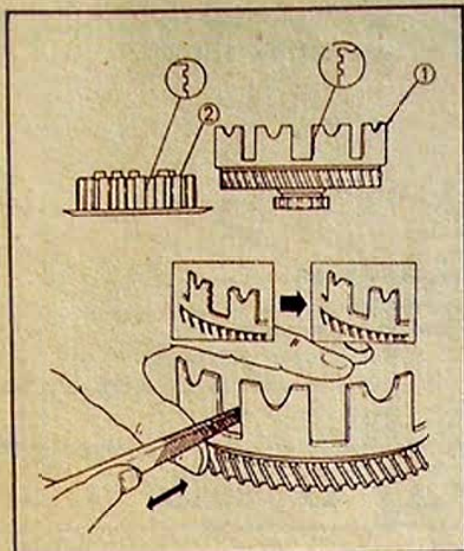

CLUTCH Clutch Housing

1. Inspect:
 - Dogs on housing ①
 - Cracks/Wear/Damage → Deburr or replace.
2. Check:
 - Circumferential play
 - Play → Replace.

NOTE: _____

DO NOT CLEAN WITH PETROL

Clutch Boss

1. Inspect:
 - Clutch boss splines ②
 - Scoring/Wear/Damage → Deburr or replace.

NOTE: _____

Scoring on clutch plate splines will cause erratic operation.

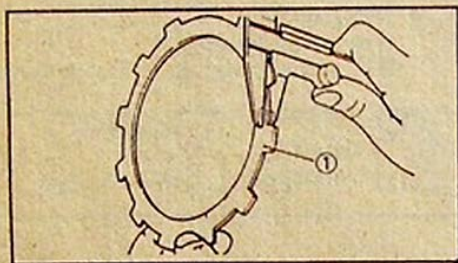

Friction Plate

1. Inspect:
 - Friction plates ①
 - Damage/Wear → Replace as a set
2. Measure:
 - Friction plate thickness
 - Measure all at four points.
 - Out of specification → Replace as a set.



Wear Limit:
2.7 mm

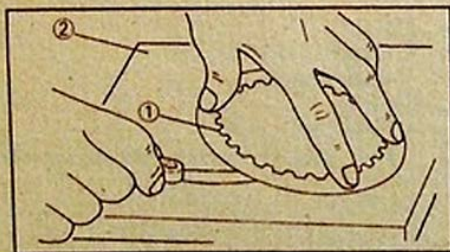

Clutch Plate

1. Measure:
 - Clutch plate ① warpage
 - Use surface plate ② and feeler gauge.
 - Out of specification → Replace.

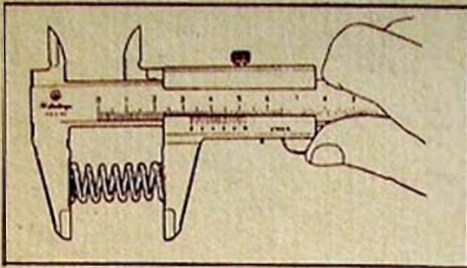

Warp Limit:
0.05 mm

**Clutch Spring**

1. Measure:
 - Free length
 - Out of specification → Replace as a set.

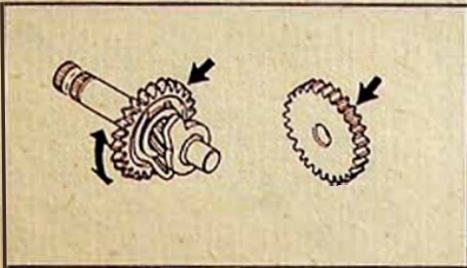

Minimum Length:
33 mm

**KICK STARTER**

1. Inspect:
 - Kick gear teeth
 - Kick idle gear teeth
 - Wear/Damage → Replace.
2. Check:
 - Kick gear movement
3. Measure:
 - Kick clip friction force
 - Out of specification → Replace kick clip.

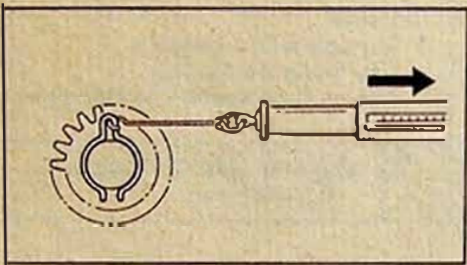

Kick Clip Friction Force:
0.8~1.2 kg

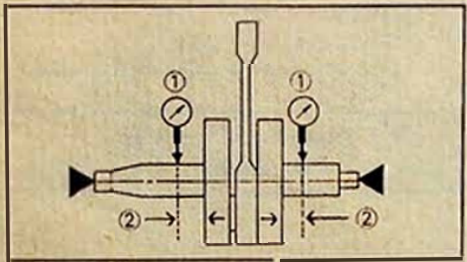
**CRANKSHAFT**

1. Measure:
 - Runout ①
 - Use Dial Gauge ①
 - Out of specification → Repair or replace.
 - ② 7.5 mm



Runout Limit:
0.03 mm

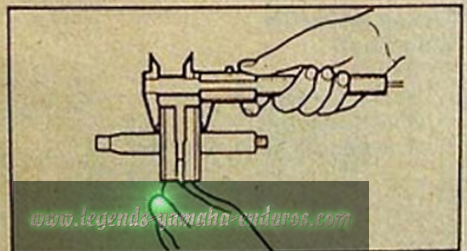

2. Measure:
 - Crank width
 - Out of specification → Repair or replace.



Crank Width:
55.90~55.95 mm



CHAPTER 4 CARBURETION

CARBURETTOR	4-1
SECTION VIEW	4-1
WORKING RANGE OF EACH COMPONENT	4-1
REMOVAL AND DISASSEMBLY	4-2
INSPECTION	4-2
REED VALVE	4-3
INSPECTION	4-3



CARBURETTOR

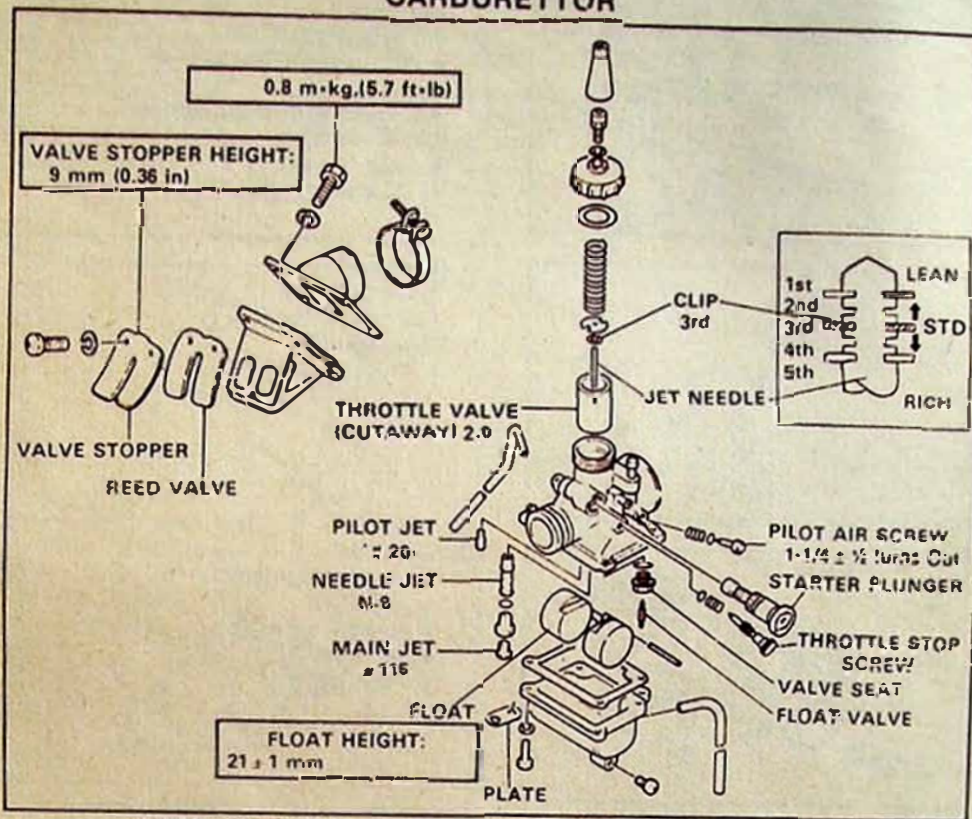

SECTION VIEW

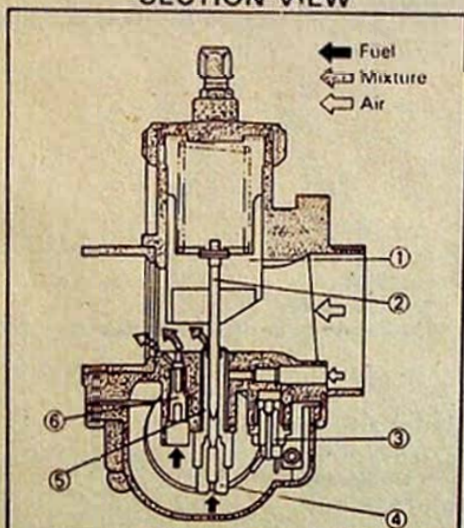

- ① Throttle valve
- ② Jet needle
- ③ Needle valve
- ④ Main jet
- ⑤ Needle jet
- ⑥ Pilot jet

WORKING RANGE OF EACH COMPONENT

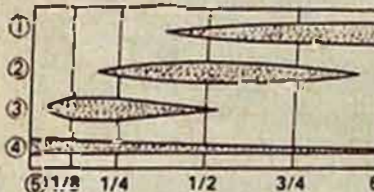

- ① Main jet
- ② Needle jet & Jet needle
- ③ Throttle valve cutaway
- ④ Pilot air screw & jet
- ⑤ Closed
- ⑥ Full open

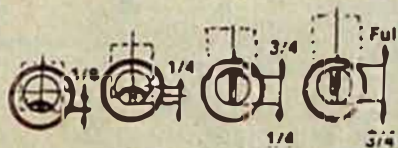



CARBURETTOR

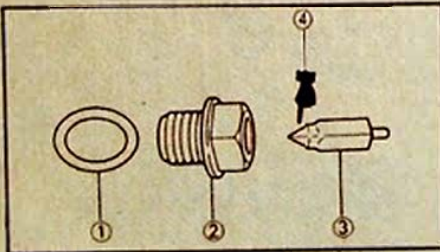
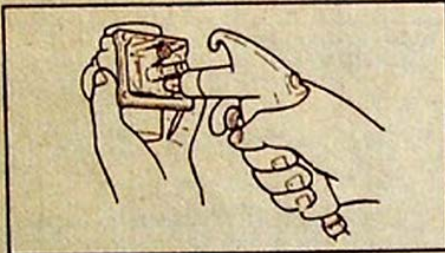
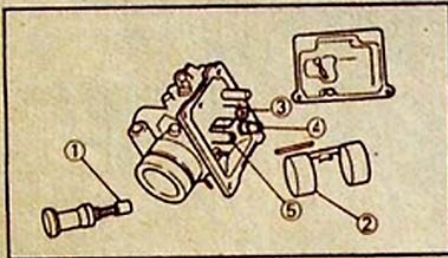
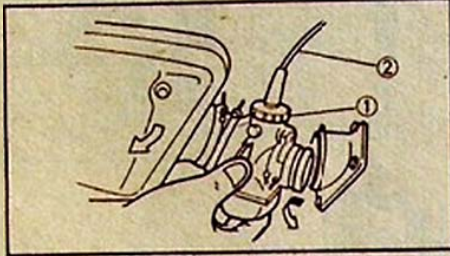
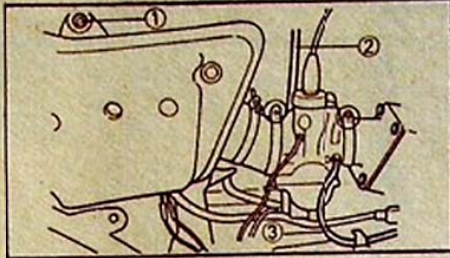

REMOVAL AND DISASSEMBLY

1. Remove:
 - Right side cover
 - Air cleaner case screws ①
2. Loosen:
 - Carburettor joint screw
3. Disconnect:
 - Fuel hose ②
 - Oil delivery hose ③
4. Remove:
 - Carburettor
 - Carburettor top ①
5. Disconnect:
 - Throttle cable ②
6. Remove:
 - Starter plunger ①
 - Float ②
 - Needle valve ③
 - Main jet ④
 - Pilot jet ⑤

INSPECTION

1. Using high pressure air, blow out all passages and jets.
2. Inspect:
 - Needle valve
 - Damaged or worn → Replace as a set.

- ① Gasket
- ② Valve seat
- ③ Needle valve
- ④ Check here.

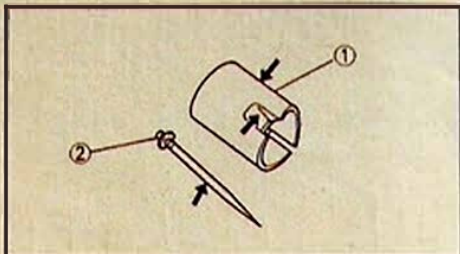

3. Inspect:
- Throttle valve (1)
 - Jet needle (2)
- Scratch/Bent → Replace.

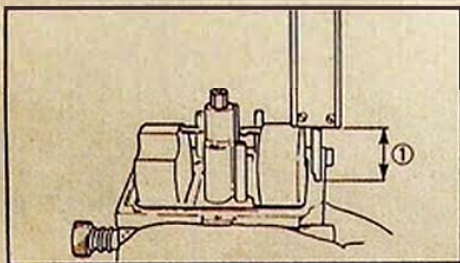

2. Measure:
- Float height (1) Without Gasket
- Incorrect → Adjust



Float Height: 21.0 ± 1.0 mm

NOTE:
The float should be just resting on, but not depressing, the spring loaded inlet needle.

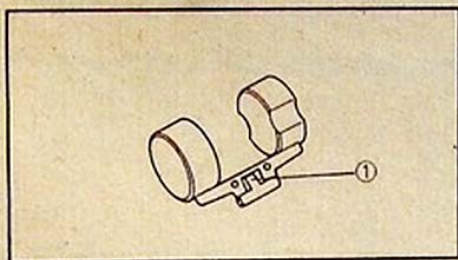

5. Adjust:
- Float height by bending the tang (1)

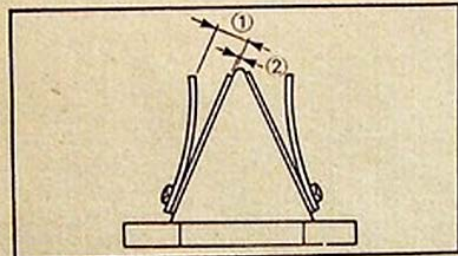

REED VALVE INSPECTION

1. Measure:
- Valve stopper height (1)
 - Reed valve bending (2)
- Out of specification → Adjust.
Out of specification → Replace.



Valve Stopper Height: 9 mm
Reed Valve Bending Limit: 0.3 mm

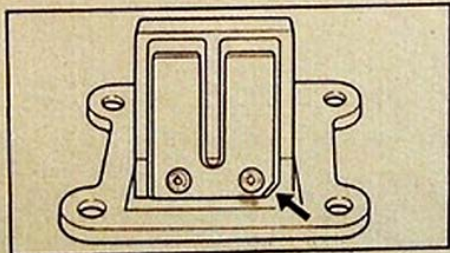

NOTE:
Note the cut in the lower corner of the reed and stopper plate.



CHAPTER 5 CHASSIS

WHEELS, BRAKES, SPROCKETS AND CHAIN	5-1
FRONT WHEEL REMOVAL	5-1
REAR WHEEL REMOVAL	5-2
INSPECTION	5-3
INSTALLATION	5-4
FRONT FORK	5-5
REMOVAL	5-5
DISASSEMBLY	5-6
INSPECTION	5-6
REASSEMBLY	5-7
INSTALLATION	5-7
STEERING HEAD	5-8
REMOVAL	5-8
INSPECTION	5-9
INSTALLATION	5-9
REAR SHOCK ABSORBERS AND SWINGARM	5-11
REMOVAL	5-11
INSPECTION	5-12
INSTALLATION	5-12



WHEELS, BRAKES, SPROCKETS AND CHAIN

WHEELS, BRAKES, SPROCKETS AND CHAIN

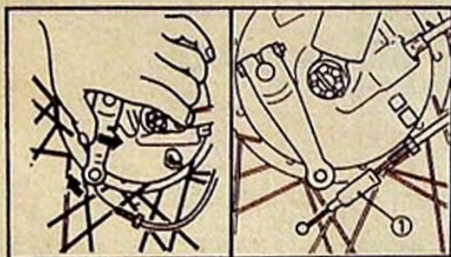
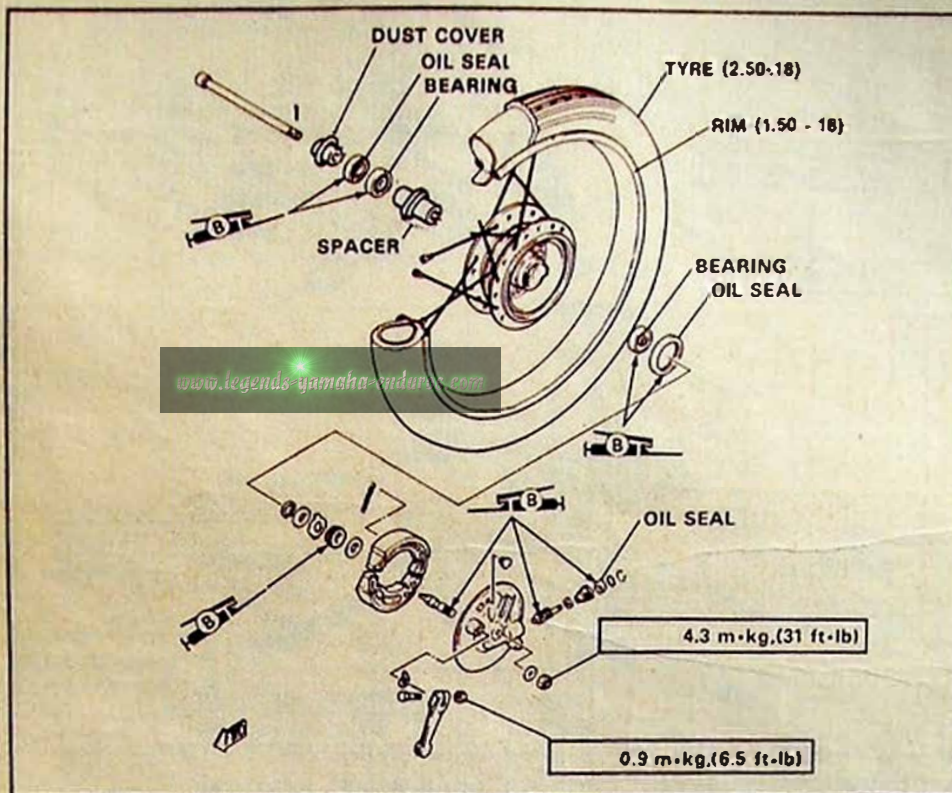

FRONT WHEEL REMOVAL

1. Place a suitable stand under the engine.
2. Disconnect:
 - Brake cable ①

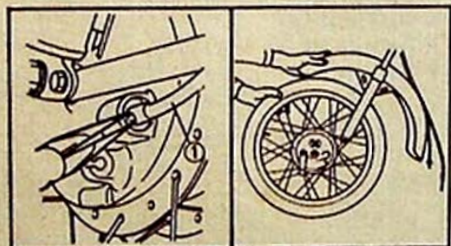

3. Disconnect:
 - Speedometer cable ①
4. Remove:
 - Cotter pin
 - Axle nut
 - Axle shaft
 - Front wheel



STEERING HEAD

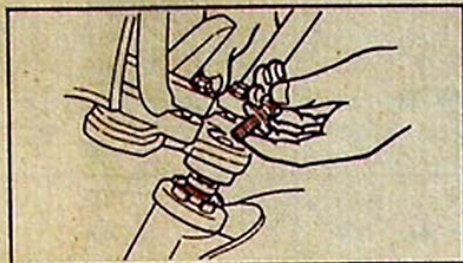

4. Install:
- Front forks
 - Handle crown
 - Steering fitting bolt



Fitting Bolt:
4.0 m·kg.(29 ft·lb)

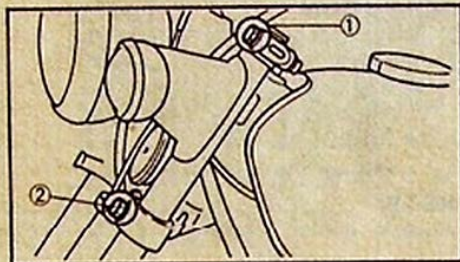

5. Tighten:
- Inner tube pinch bolts



Inner Tube Pinch Bolt:
Upper ① : 1.5 m.kg, (11 ft.lb)
Lower ② : 3.0 m.kg, (22 ft.lb)





REAR SHOCK ABSORBER AND SWINGARM

REAR SHOCK ABSORBER AND SWINGARM

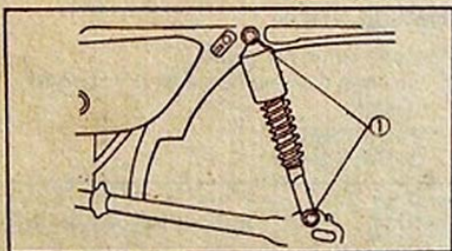
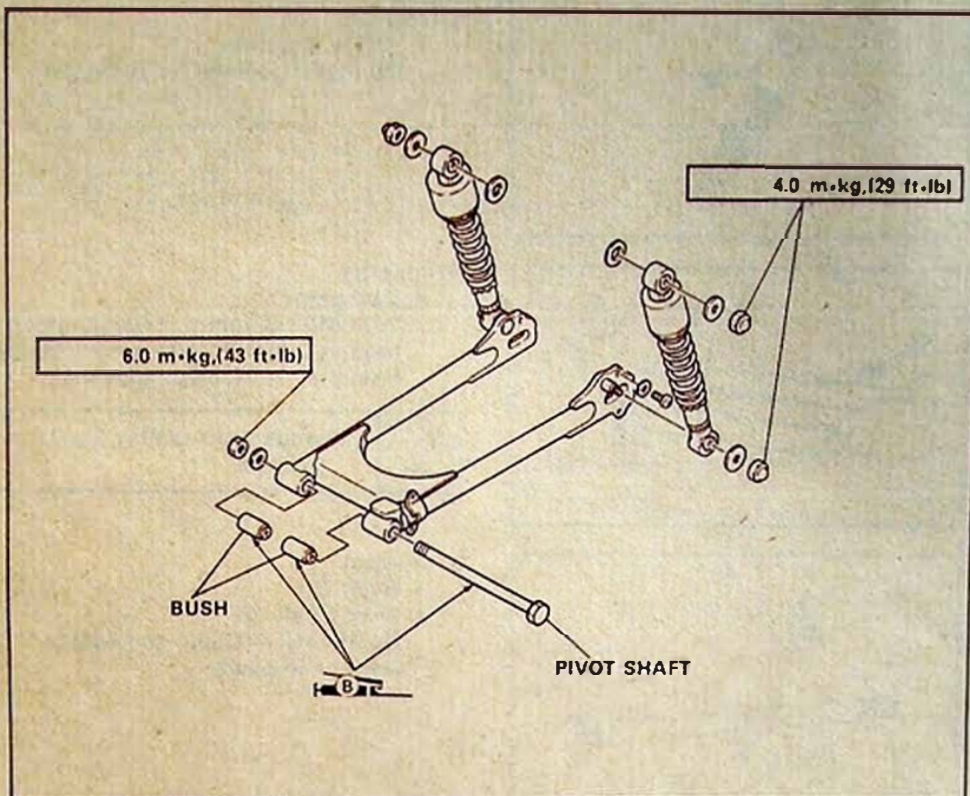

REMOVAL

1. Remove:
 - Rear wheel
 - Chain case
 - Driven sprocket
 - Drive chain
2. Remove:
 - Shock absorber mount bolts ①
 - Shock absorbers

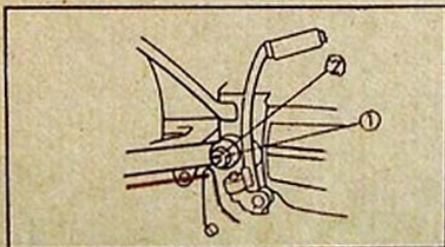

3. Remove:
 - Pivot shaft nut ①
 - Pivot shaft ②
 - Swingarm



REAR SHOCK ABSORBER AND SWINGARM

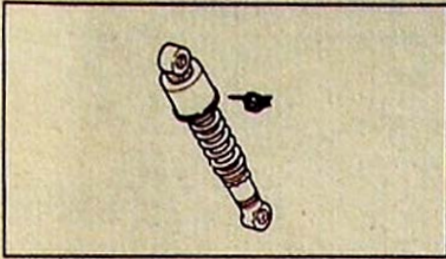

INSPECTION

1. Inspect:
 - Shock absorber
 - Oil leaks/Damage → Replace.

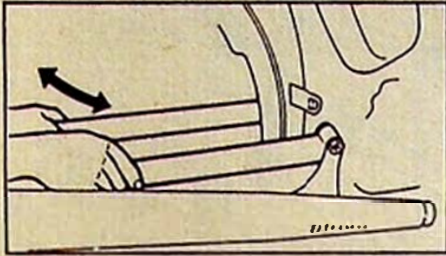

2. Inspect:
 - Swingarm
 - With the swingarm installed grasp the swingarm end to check for free play.
 - Free play → Replace bushes.



Swingarm Free Play Limit:
2.0 mm

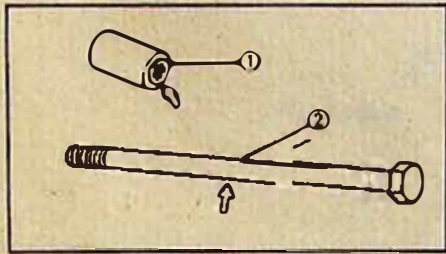

3. Inspect:
 - Bush ①
 - Pivot Shaft ②
 - Rust/Dirty → Clean or Replace.
 - Bent → Replace

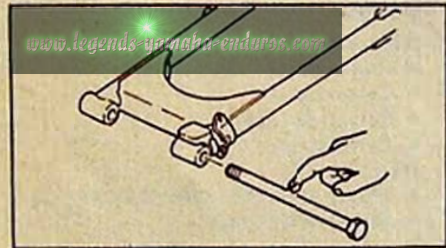

INSTALLATION

Reverse removal steps.

1. Grease the bushes and pivot shaft.
2. Install:
 - Swingarm
 - Pivot shaft



6.0 m·kg.(43 ft·lb)



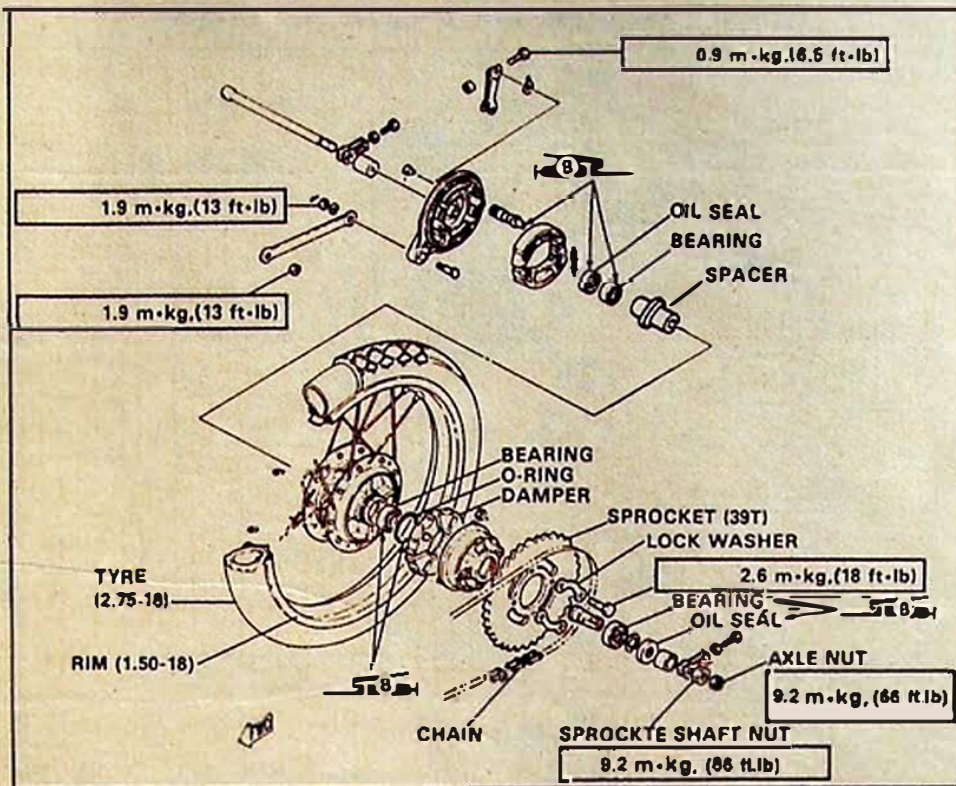

REAR WHEEL REMOVAL

1. Place the motorcycle on its centerstand.
2. Remove:
 - Brake tension bar ①
 - Brake rod ②
3. Remove:
 - Cotter pin ①
 - Axle nut ②
 - Axle shaft
 - Rear wheel

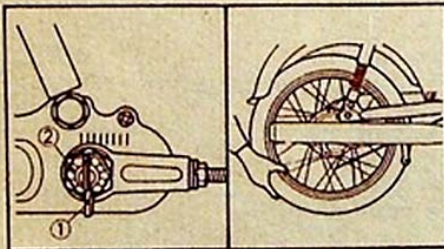
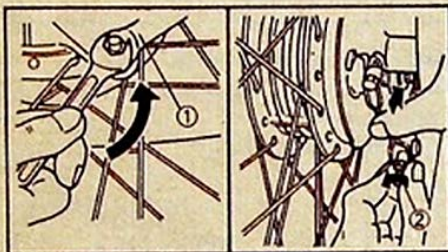

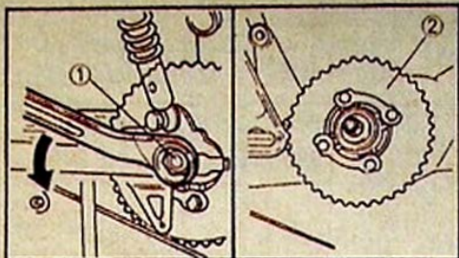

4. Remove:
- Chain case
 - Sprocket shaft nut ①
 - Sprocket assembly ②
 - Drive chain

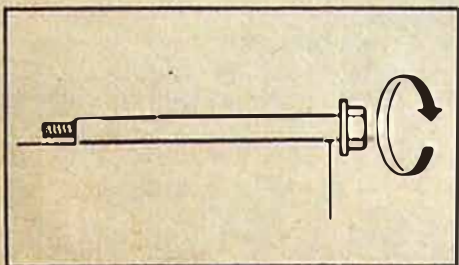

INSPECTION

1. Inspect:
- Axle shaft
Roll the axle shaft on a Flat Surface.
Bends → Replace.

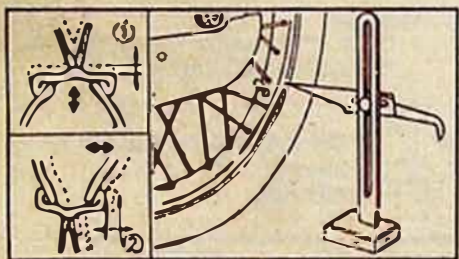

2. Inspect:
- Wheel
Cracks/Heavily Bends → Replace.
3. Measure:
- Wheel runout
Out of specification → Retighten or Replace.



Rim Runout Limits:

- Radial ① — 2.0 mm
- Lateral ② — 2.0 mm

4. inspect:
- Wheel bearings
Bearings allow play in the wheel hub or wheel turns roughly → Replace.

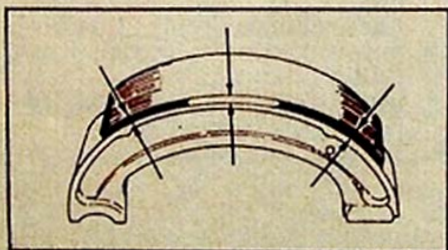

5. Measure:
- Brake shoe thickness
Out of specification → Replace.



Brake Shoe Wear Limit:

2 mm

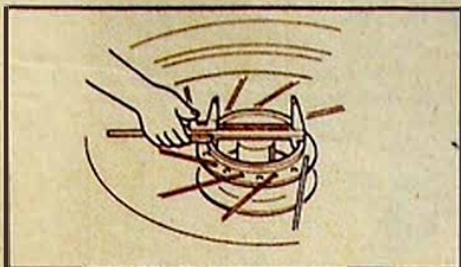

6. Measure:
- Brake drum inside diameter
 - Out of specification → Replace.

 **Brake Drum Wear Limit:**
131 mm

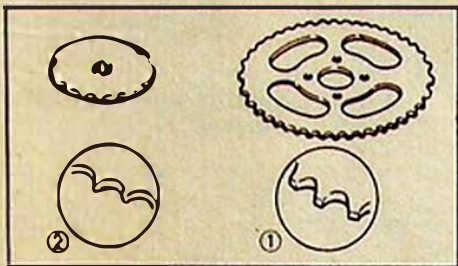

7. Inspect:
- Drive sprocket
 - Driven sprocket
 - Wear → Replace with the chain as a set.

- ① Good
- ② No Good

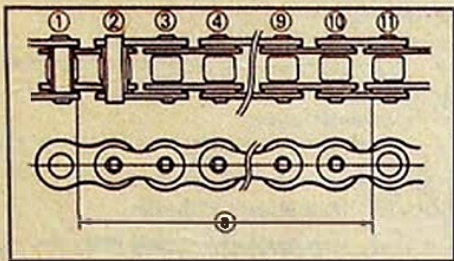

8. Measure:
- Drive chain length (10 Links) (a)
 - Out of specification → Replace.

 **Drive Chain Length (10 Links) Limit:**
121 mm

INSTALLATION

1. Install:
- Wheels
 - Reverse removal steps.

Note the following installation points:

- Lightly grease the wheel oil seal lips and gear teeth of the speedometer drive and driven gears.
(Use lightweight, lithium base grease.)
- Be sure that the torque stopper is positioned correctly.
- Install the chain clip with rounded-end facing the direction of travel.

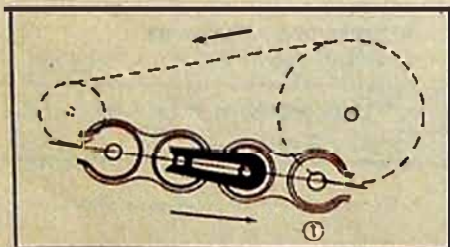

- ① Drive direction



FRONT FORK

FRONT FORK

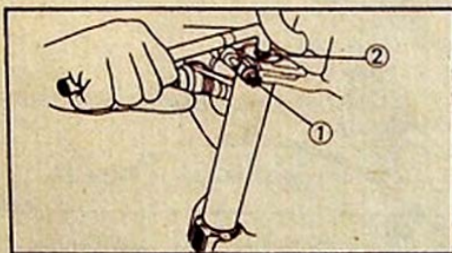
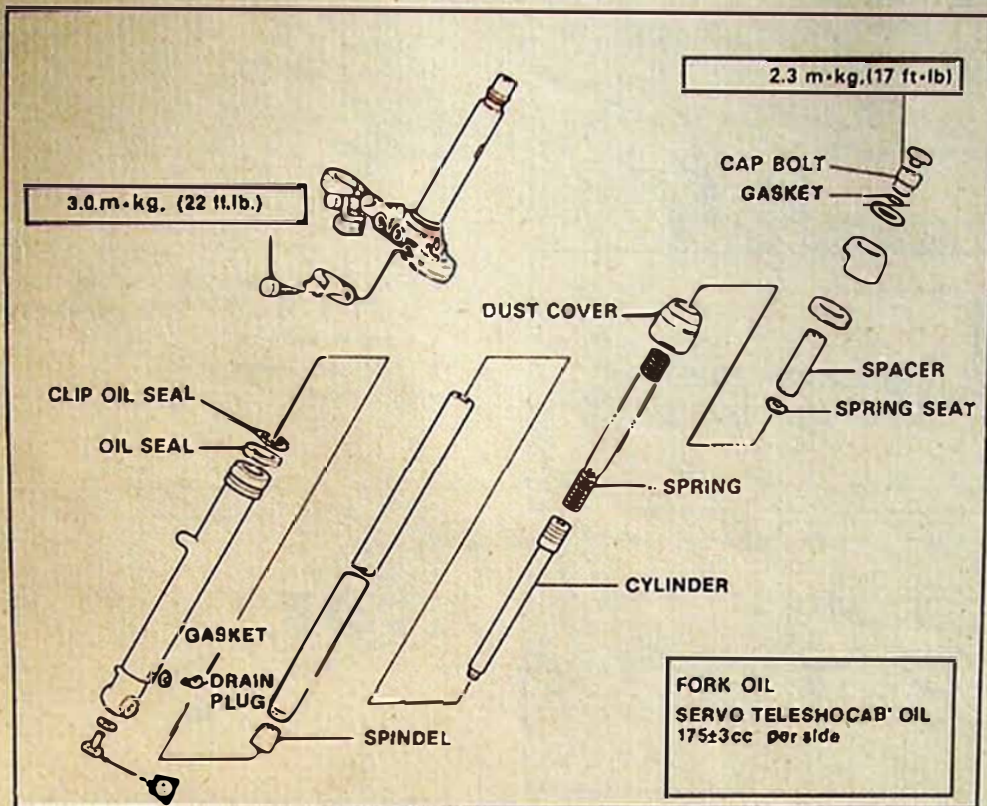

REMOVAL

1. Remove:
 - Front wheel
 - Front fender
2. Loosen:
 - Front fork pinch bolt ①
 - Cap bolt ②
 Use Top Plug Spanner (ESM-10000214) ③
3. Loosen:
 - Front fork pinch bolt (Lower) ①
4. Remove:
 - Front fork

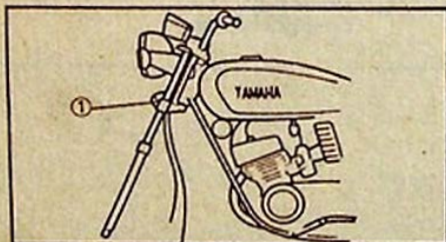

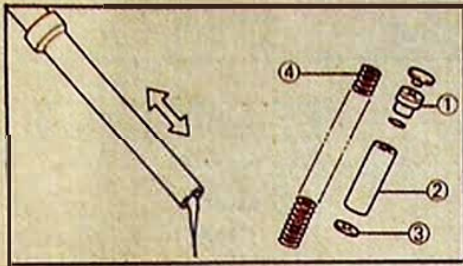

FRONT FORK

**DISASSEMBLY**

1. Remove:
 - Cap bolt (1)
 - Spacer (2)
 - Spring seat (3)
 - Spring (4)
2. Drain:
 - Fork oil
3. Remove:
 - Bolt Hex Sockethead rod securing bolt (1)
Use T-Handle (2). (ESM-100000213)
 - Inner tube (3)
 - Cylinder Complete (4)
 - Spindle (5)

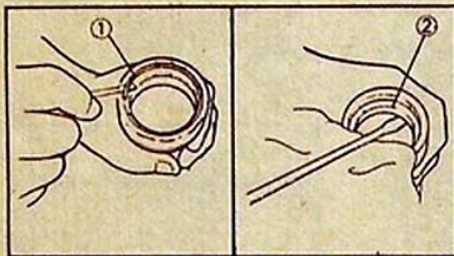
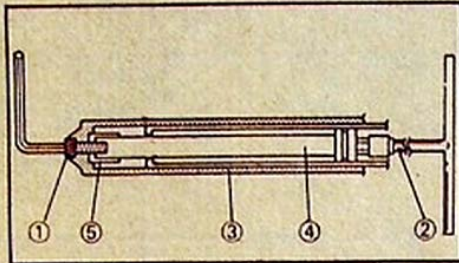

4. Remove:
 - Dust cover (1)
 - Clip Oil seal (1)
 - Oil seal (2)

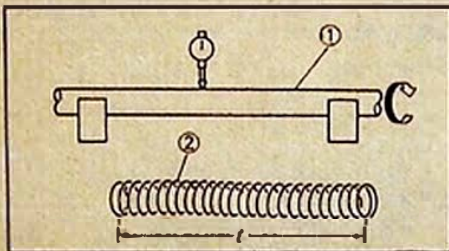
**INSPECTION**

1. Inspect:
 - Inner tube (1)
 - Outer tube
Scratches/Bands/Damage → Replace.
2. Measure:
 - Fork spring (2)
Out of specification → Replace.



Fork Spring Free Length:
286.5 mm
Limit 291.5 mm



FRONT FORK

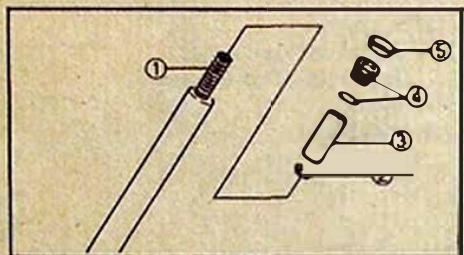
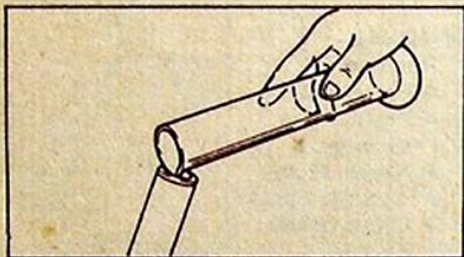
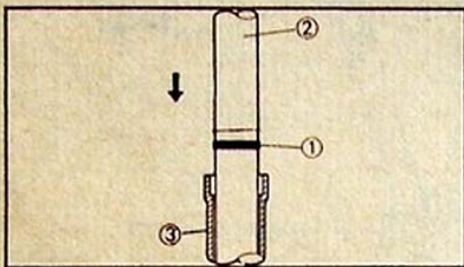
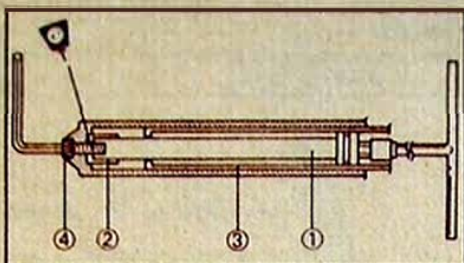

ASSEMBLY

1. Install:

- Cylinder Complete ①
- Spindle ②
- Inner tube ③
- Bolt Hex Socket Hd ④



Cylinder Comp.
2.3 m.kg. (17 ft.lb)
LOCTITE OR EQUIVALENT.

2. Install:

- Oil seal ①
- Clip oil seal
- Dust cover

- ② Inner tube
- ③ Outer tube

3. Fill:

- Front fork



Each Fork:
175 ± 3cc
SERVO TELESOCAB' OIL

4. Install:

- Fork spring ①
- Spring seat ②
- Spacer ③
- Cap bolt ④
- Rubber cap ⑤

- 5. After installing the front fork, tighten the cap bolt.



Cap Bolt:
2.3 m.kg. (17 ft.lb)



STEERING HEAD

STEERING HEAD

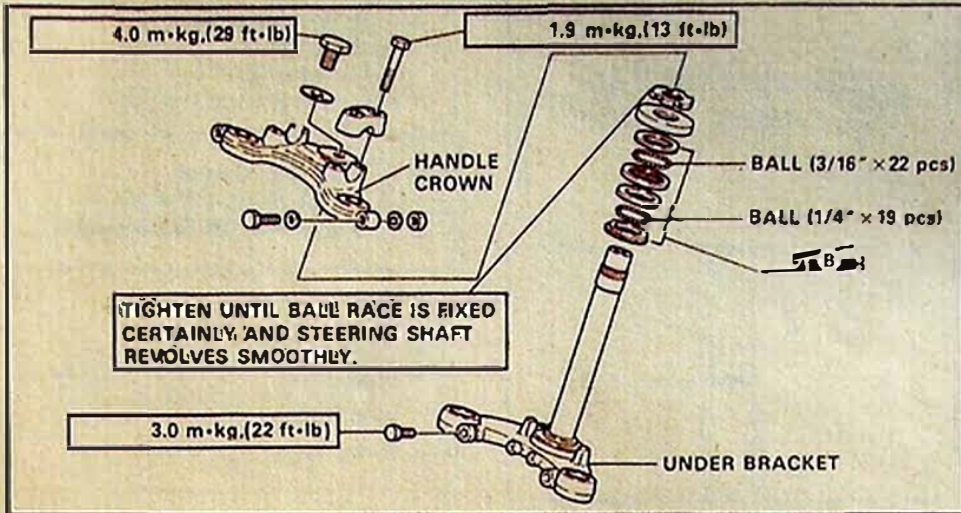

REMOVAL

1. Remove:
 - Front wheel
 - Front forks
2. Disconnect:
 - Brake cable
 - Throttle cable
 - Clutch cable
3. Disconnect:
 - Electrical lead wires (in the headlight case)
4. Remove:
 - Headlight
5. Remove:
 - Steering fitting bolt
 - Handle crown assembly
 - Headlight stays (together with headlight case)

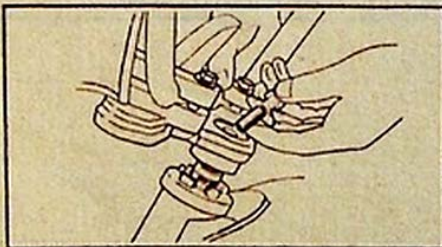
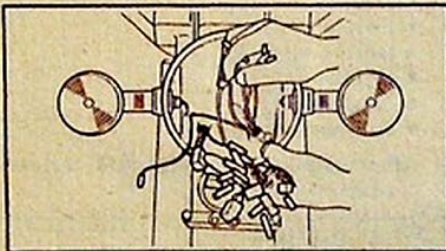



STEERING HEAD



6. Remove:
- Forkstem nut (1)
 - Bearing cover (2)

NOTE: _____
Support the under bracket not to lose any bearings.

- Under bracket
- Bearings

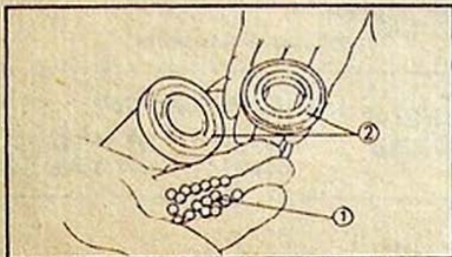
**INSPECTION**

1. Wash the bearings in solvent.
2. Inspect:
 - Bearings (1)
Pitting/Damage → Replace.
 - Bearing races (2)
Pitting/Damage → Replace.

NOTE: _____
Always replace bearing and race as a set.

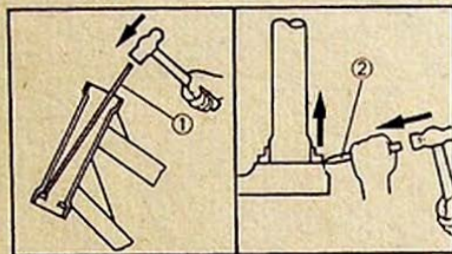

3. When replacing the bearing, use a long rod (1) and cold chisel (2) to remove the race.

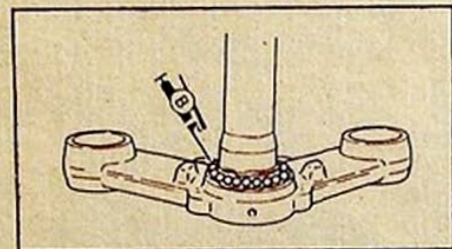
**INSTALLATION**

1. Grease the bearings and races.

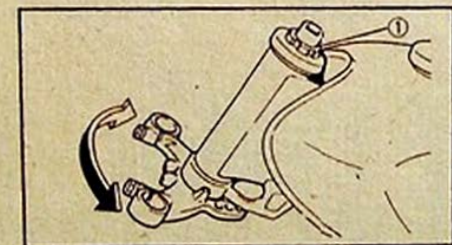

2. Install:
 - Under bracket
 - Bearing cover
 - Ring nut
3. Tighten:
 - Ring nut (1)
(so all free play is taken up, but so the bracket can still pivot freely.)





CHAPTER 6 ELECTRICAL

CIRCUIT DIAGRAM	6-1
IGNITION SYSTEM	6-3
CHARGING SYSTEM	6-5
LIGHTING SYSTEM	6-6
SIGNAL SYSTEM	6-7
SWITCH INSPECTION	6-7



CIRCUIT DIAGRAM

Additional electrical accessories may overload the existing electrical system. Severe overloads may damage the wiring harness or create a dangerous situation due to the loss of electrical power during the operation of the motorcycle.

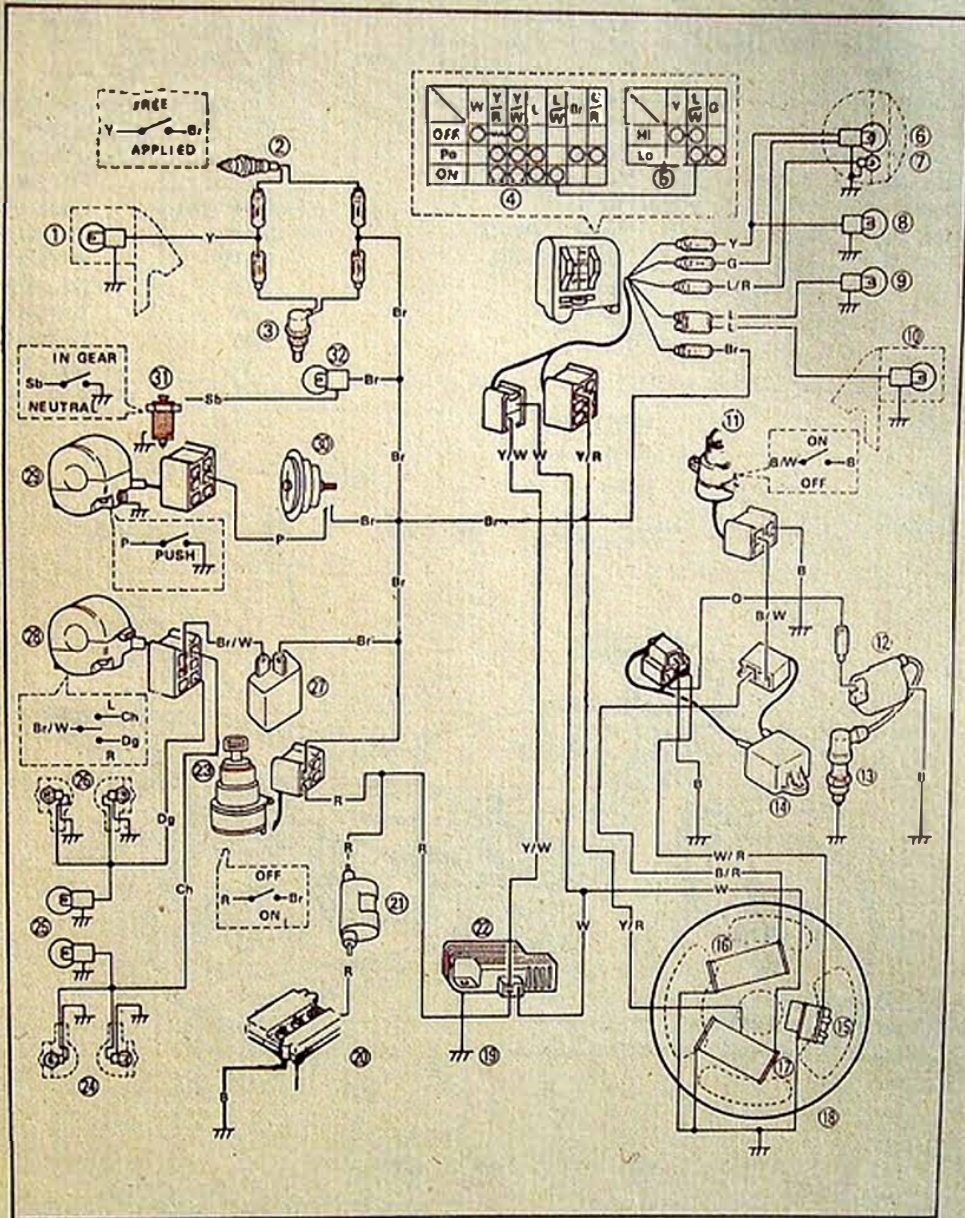



CIRCUIT DIAGRAM

- 1 Brake light
- 2 Front brake switch
- 3 Rear brake switch
- 4 Light switch
- 5 Dimmer switch
- 6 Headlight
- 7 Park light
- 8 "HIGH BEAM" indicator
- 9 Meter light
- 10 Tail light
- 11 Main switch
- 12 Ignition coil
- 13 Spark plug
- 14 CDi unit
- 15 Pulsar coil
- 16 Source coil

- 17 Charge/lighting coil
- 18 C.D.I. magneto
- 19 Body earth
- 20 Battery
- 21 Fuse
- 22 Rectifier/Regulator
- 23 Main switch
- 24 Flasher lights (left)
- 25 Flasher pilot light
- 26 Flasher lights (right)
- 27 Flasher relay
- 28 Flasher switch
- 29 Horn switch
- 30 Horn
- 31 Neutral switch
- 32 Neutral light

COLOR CODE

B	Black
Br	Brown
Ch	Chocotate
Dg	Dark green
G	Green
L	Blue
P	Pink
R	Red
Sb	Sky blue
W	White
O	Orange
Y	Yellow
B/R	Black/Red
B/W	Black/White
Br/W	Brown/White
W/R	White/Red
Y/R	Yellow/Red
Y/W	Yellow/White
L/W	Blue/White
L/R	Blue/Red
G/Y	Green/Yellow

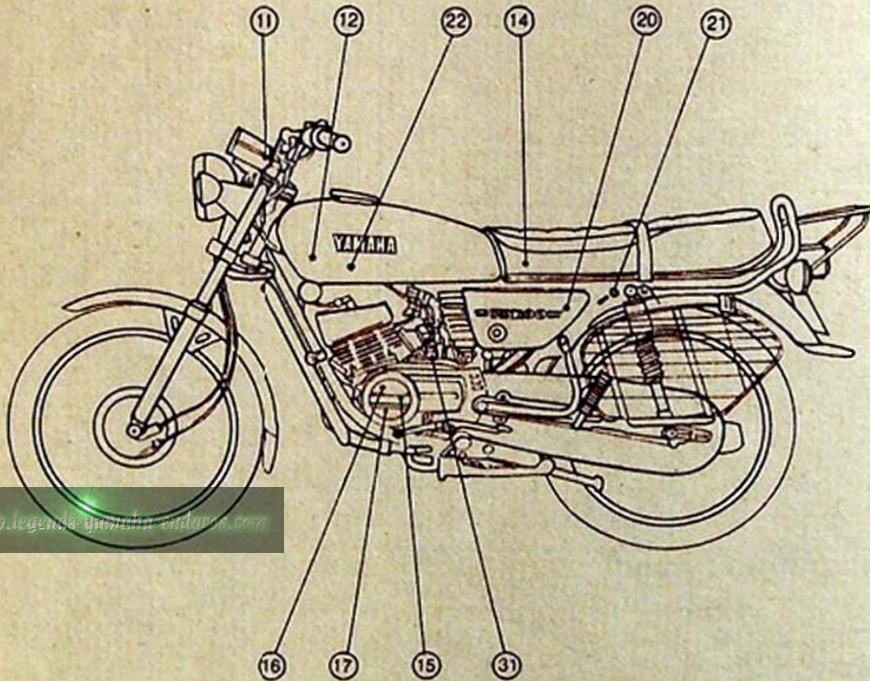

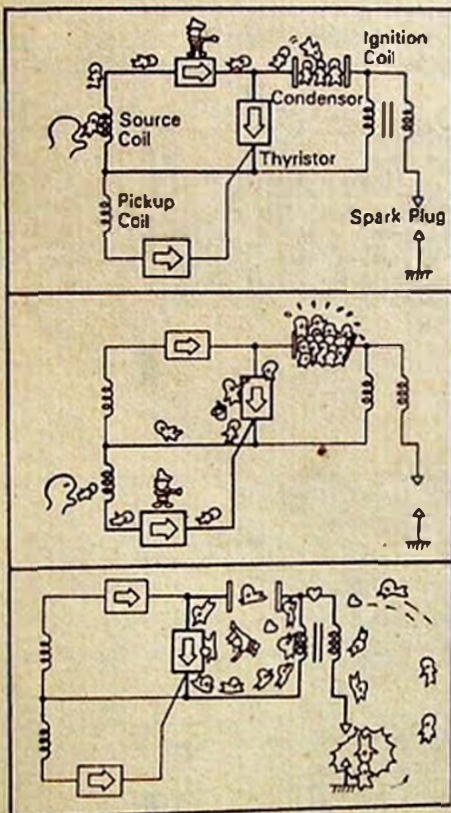
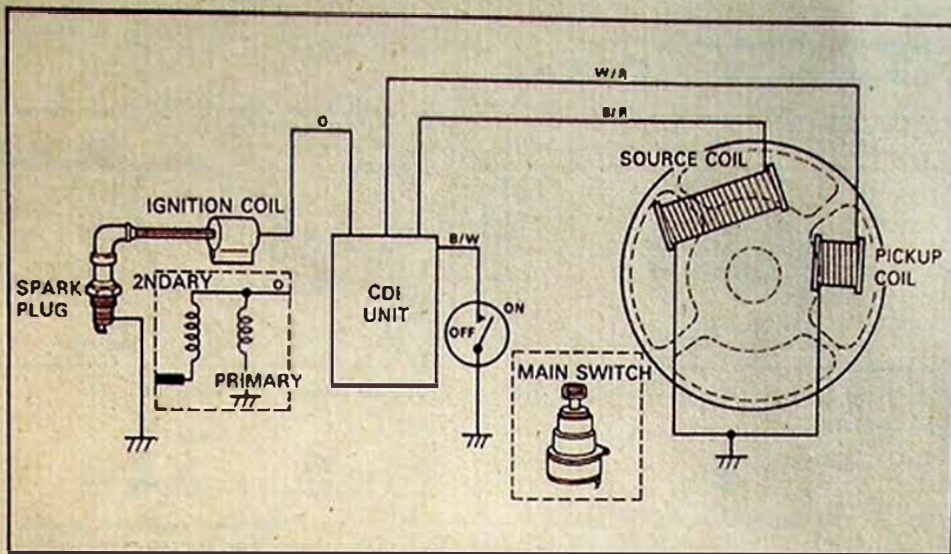

FUNCTION

Function No. 1

As the rotor turns, current is produced in the source coil and then stored in the ignition condenser.

Function No.2

At the same time, the pickup coil sends a pulse (signal) to activate the thyristor.

Function No.3

Then, the ignition condenser discharges the stored current rapidly. This induces a high voltage in the ignition coil, and a strong spark is produced.

TROUBLESHOOTING CHART

All wires connection must be checked in advance.

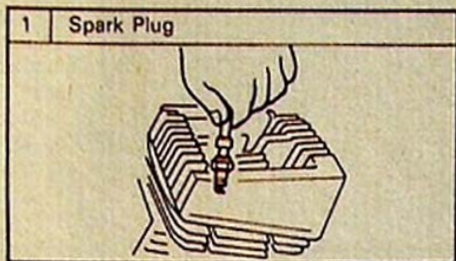

Ground the spark plug to the cylinder head and kick the starter.

No spark
or
weak spark

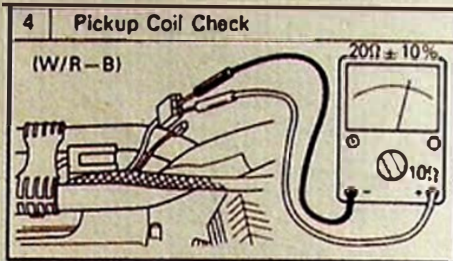

Check the pickup coil resistance.

OK ↓ NG

Replace the pickup coil

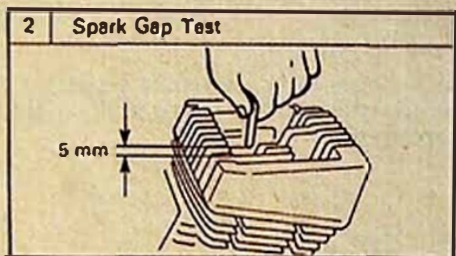

Hold the ignition lead 5 mm from the cylinder head and kick the starter.

No spark ↓ Spark

Check the plug cap
and spark plug

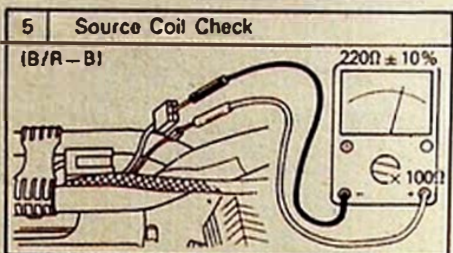

Check the source coil resistance.

OK ↓ NG

Replace the source coil

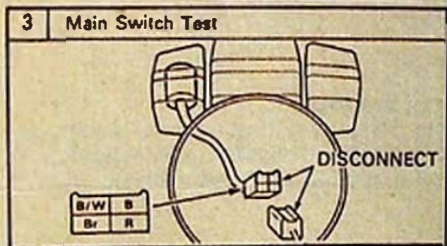

Disconnect the main switch coupler and kick the starter.

No spark ↓ Spark

Check main switch

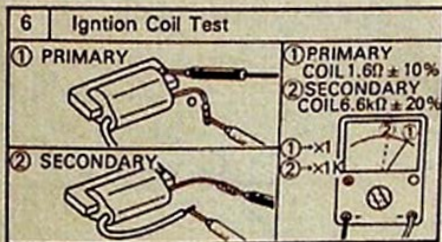

Check the resistance of the primary and secondary coil windings.

OK ↓ NG

Replace the CDI unit

Replace the ignition coil

CHARGING SYSTEM

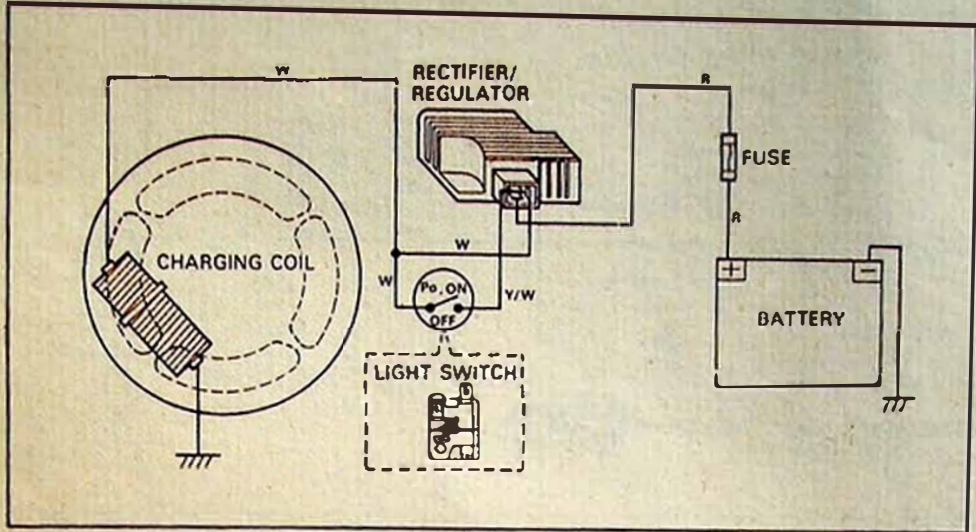

1. Charging Voltage Test

Connect the tester leads with battery terminals as shown. Start the engine and check voltage.

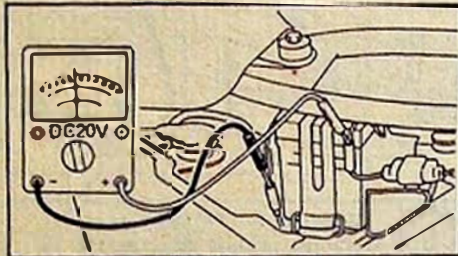

Charging Voltage: (Day)

7.5 ~ 8.0V at 5,000 r/min

2. Charging Coil Resistance

Disconnect the generator leads and check charging coil windings resistance.

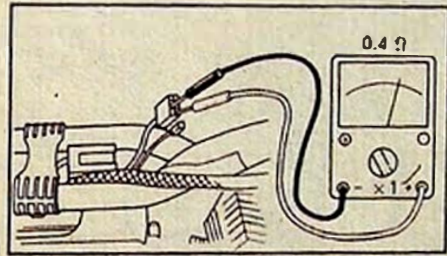

Charging Coil Resistance:

0.4 Ω ± 10%
(White - Black)

If out of specifications, check charging coil windings resistance. And if more than 9V, replace the Rectifier/Regulator.

If out of specification, replace charging coil.

LIGHTING SYSTEM

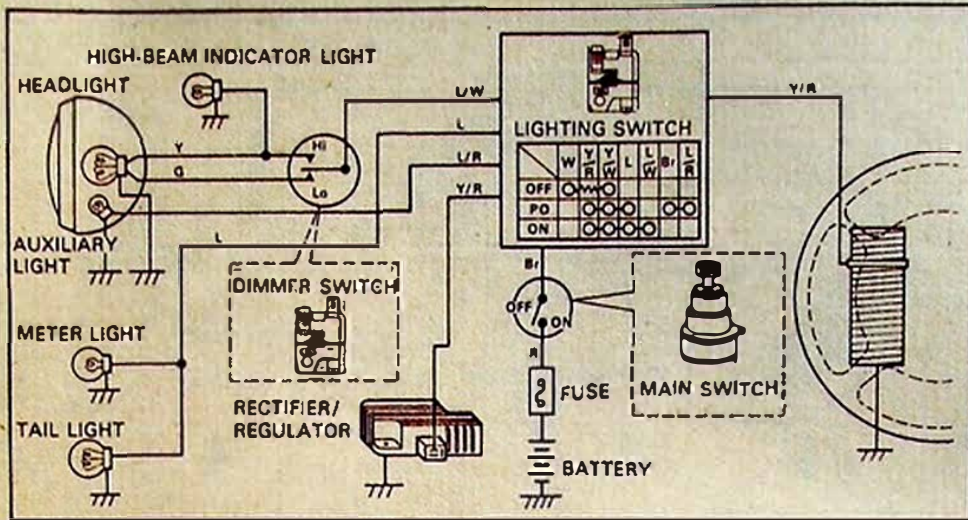

1. Lighting Voltage Test

Remove the headlight leads and connect the tester leads as shown. Start the engine and check the voltage.

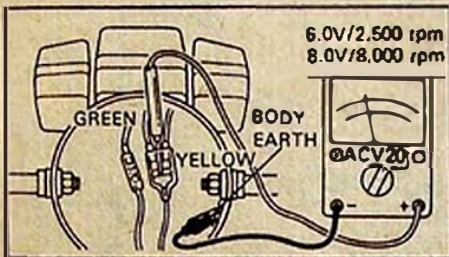

Lighting Voltage
 (Yellow-Ground) or (Green-Ground)
 6.0V or more at 2,500 r/min
 8.0V or less at 8,000 r/min

If out of specifications, check lighting coil resistance and rectifier/regulator.

2. Lighting Coil Resistance

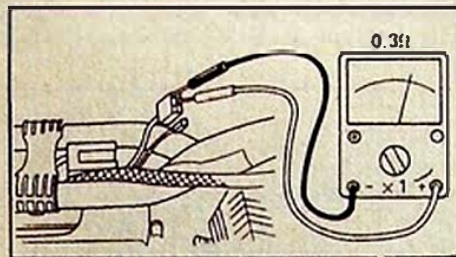

Lighting Coil Resistance
 0.3Ω ± 10% (Yellow/Red - Black)

SIGNAL SYSTEM

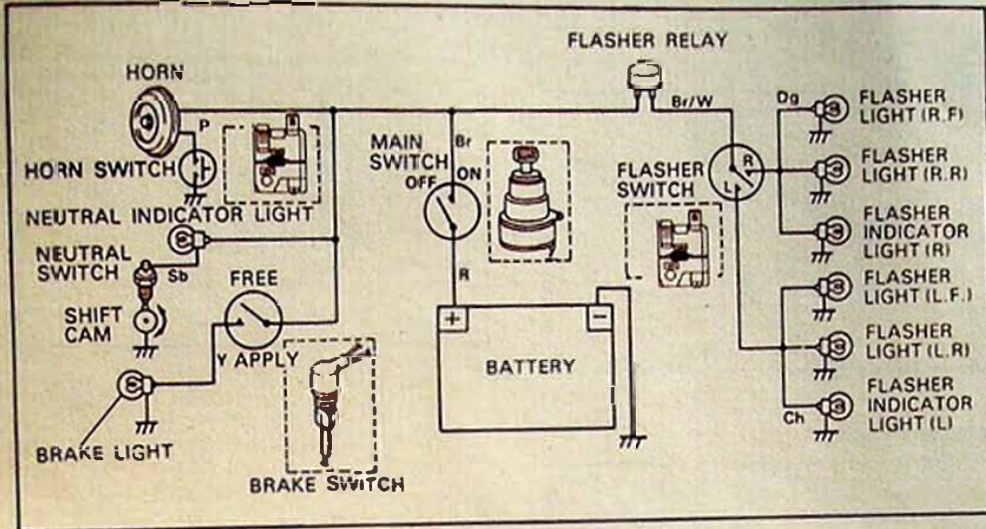

SWITCH INSPECTION

<EXAMPLES FOR LEADS CONTINUITY TEST>

B	R	Br
	○	○

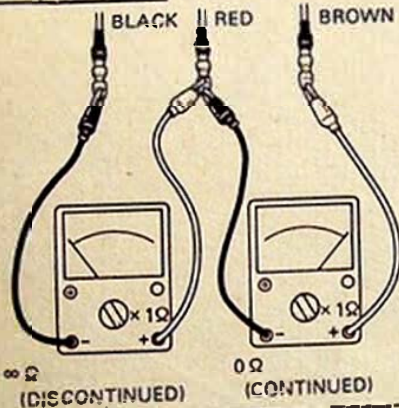

Main switch

	B	B/W	R	Br
OFF	○	○		
ON	○		○	○

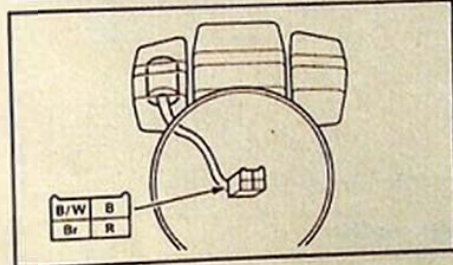

Light switch

	W	Y/R	Y/W	L	L/W	Br	L/R
OFF	○		○				
PO		○	○	○		○	○
ON		○	○	○	○		

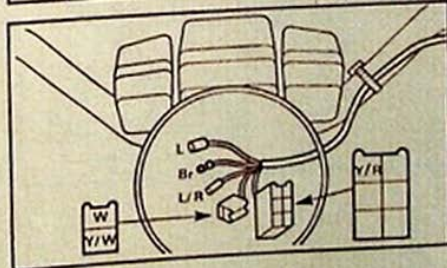



SIGNAL SYSTEM

Dimmer switch

		G	L/W	Y
Hi				
Lo				

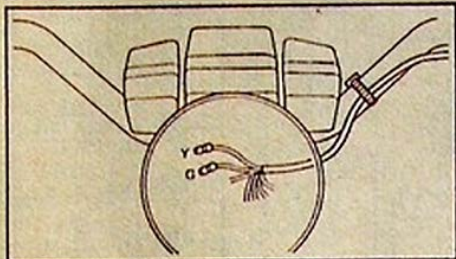

Brake switch

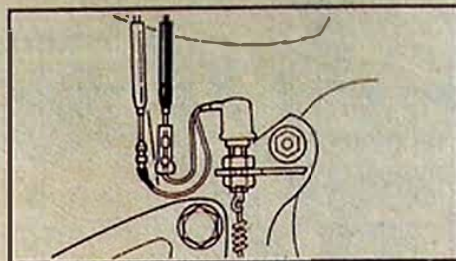
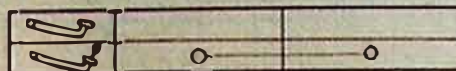

Flasher switch

		Ch	Br/W	Dg
R				
N				
L				

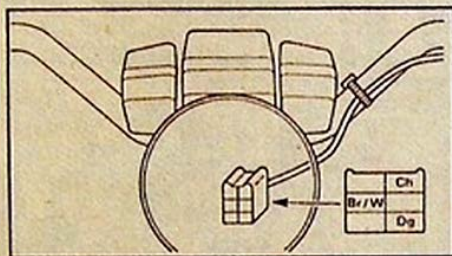

Horn switch

		P	

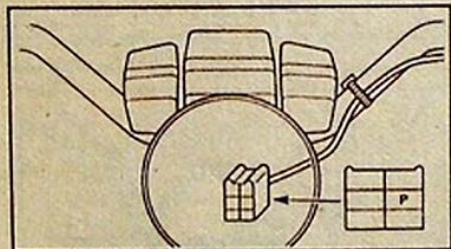



CHAPTER 7 APPENDICES

SPECIFICATIONS	7-1
CABLE ROUTINE DIAGRAM	7-13
WIRING DIAGRAM	7-15
ENGINE TROUBLESHOOTING	7-17
ELECTRICAL SYSTEM	7-18
COMPRESSION SYSTEM	7-18
INTAKE AND EXHAUST SYSTEMS	7-19





SPECIFICATION

A. GENERAL SPECIFICATIONS

Model	RX 100
Model Code Number	1L1
Frame Starting Number	1L1-00000 1
Engine Starting Number	1L1-000001
Dimensions:	
Overall Length	2040 mm
Overall Width	740 mm
Overall Height	1,050 mm
Seat Height	765 mm
Wheelbase	1,240 mm
Minimum Ground Clearance	145 mm
Basic Weight:	
With Oil and Full Fuel Tank	103 kg
Minimum Turning Radius	2,100 mm
Engine:	
Engine Type	Air cooled, 2-stroke, gasoline 7 port torque induction
Cylinder Arrangement	Single cylinder, Forward-inclined
Displacement	98 cm ³
Bore x Stroke	50 x 50 mm
Compression Ratio	6:7 : 1
Max. Power	11.0 PS @ 7,500 RPM
Starting System	Kick Starter
Lubrication System:	Separate lubrication (Yamaha Autolube Patent)
Oil Type or Grade:	
Engine Oil	Servo 2T Supreme or equivalent
Transmission Oil	Servo super 30 or equivalent
Oil Capacity:	
Oil Tank (Engine Oil)	1.3 L
Transmission Oil	0.65 L
Periodic Oil Change	0.70 L
Total Amount	
Air Filter	Wet foam (Washable)
Fuel:	
Type	Regular gasoline (87 Octane)
Tank Capacity	10.5 L
Carburettor:	
Type/Manufacturer	VM20/MIKUNI
Spark Plug:	
Type/Manufacturer	BP7HS/NGK or Equivalent
Gap	0.7 — 0.8 mm
Clutch Type	Wet, multiple-Disc





C. ELECTRICAL

Model	RX 100
Voltage	6V
Ignition System: Ignition Timing (B.T.D.C.) Advancer Type	20° ± 1.5° at 8,000 r/min Electrical
CDI: Pickup Coil Resistance (Colour) Source Coil Resistance (Colour)	20 Ω ± 10% at 20°C (68°F) (W/R-B) 220 Ω ± 10% at 20°C (68°F) (B/R-B)
Ignition Coil:	External Sealed type
Minimum Spark Gap	13 kV or more at 500 r/min 12 kV or more at 8,000 r/min 6 - 7-mm
Primary Winding Resistance Secondary Winding Resistance	1.8 Ω ± 10% at 20°C (68°F) 8.6k Ω ± 20% at 20°C (68°F)
Charging System/Type	Flywheel magneto

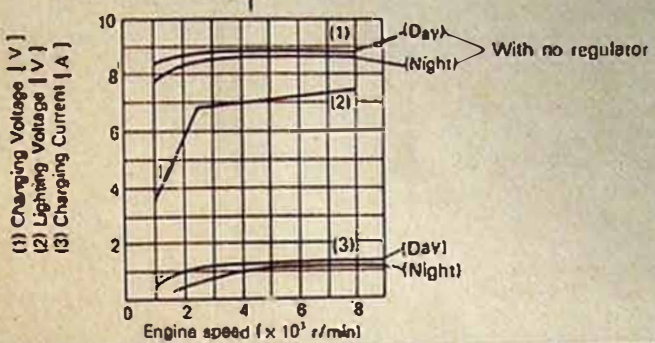
Model	RX 100
F.W. Magneto: Charging Current-Day -Night Charging Coil Resistance (Colour) Lighting Voltage Lighting Coil Resistance (Colour)	0.7A or more at 2,500 r/min 3.0A or less at 8,000 r/min 0.4A or more at 2,500 r/min 3.0A or less at 8,000 r/min 0.4Ω ± 10% at 20°C (68°F) (W-B) 6.0V or more at 2,500 r/min 8.0V or less at 8,000 r/min 0.3Ω ± 10% at 20°C (68°F) (Y/R-B)
 <p style="font-size: 0.8em;"> (1) Charging Voltage [V] (2) Lighting Voltage [V] (3) Charging Current [A] </p> <p style="font-size: 0.8em;"> (1) (Day) (1) (Night) (2) (3) (Day) (3) (Night) </p> <p style="font-size: 0.8em;"> With no regulator </p> <p style="font-size: 0.8em;"> Engine speed (x 10³ r/min) </p>	



SPECIFICATIONS

Model	RX 100
Rectifier/Regulator No Load Regulator Voltage (Charging) (Lighting) Capacity (Charging) (Lighting)	7.5 — 8.0V Less than 8.8V 4.0A 8.0A
Battery: Capacity Specific Gravity	6V 4AH 1.240/20°C.
Horn: Type/Quantity Maximum Amperage	Plain type × 1 3.0A
Flasher Relay: Type Flasher Frequency Wattage	Condenser type 60 — 120 cycle/min 10W × 2 → 3W
Circuit Breaker: Type Amperage for Individual Circuit/Quantity Main Spare	Fuse 10A × 1 10A × 1



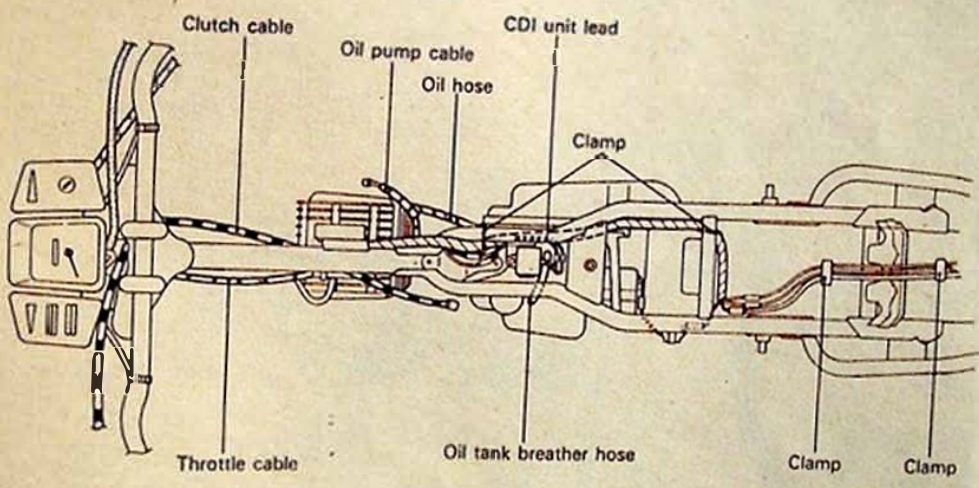
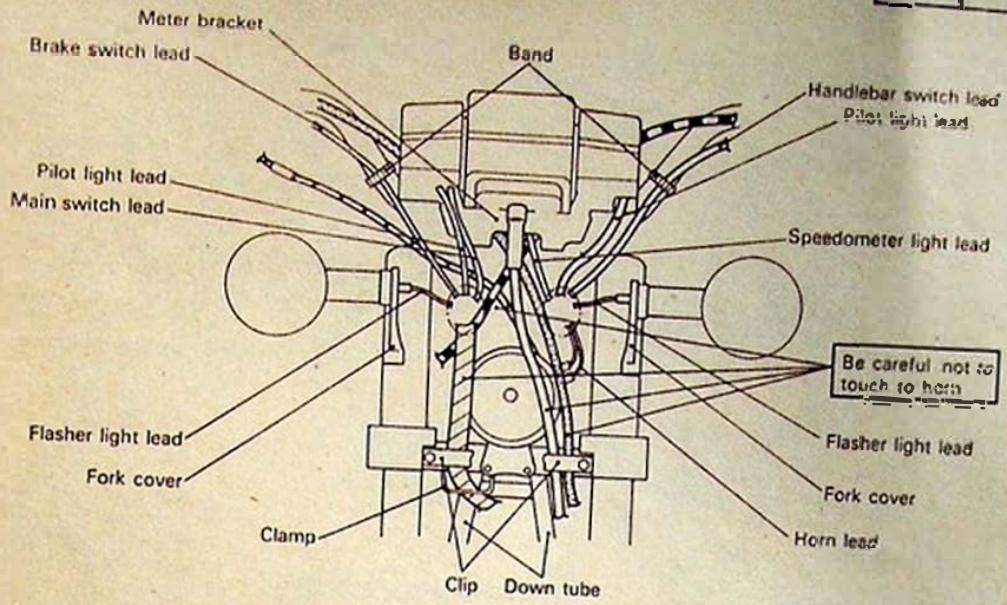

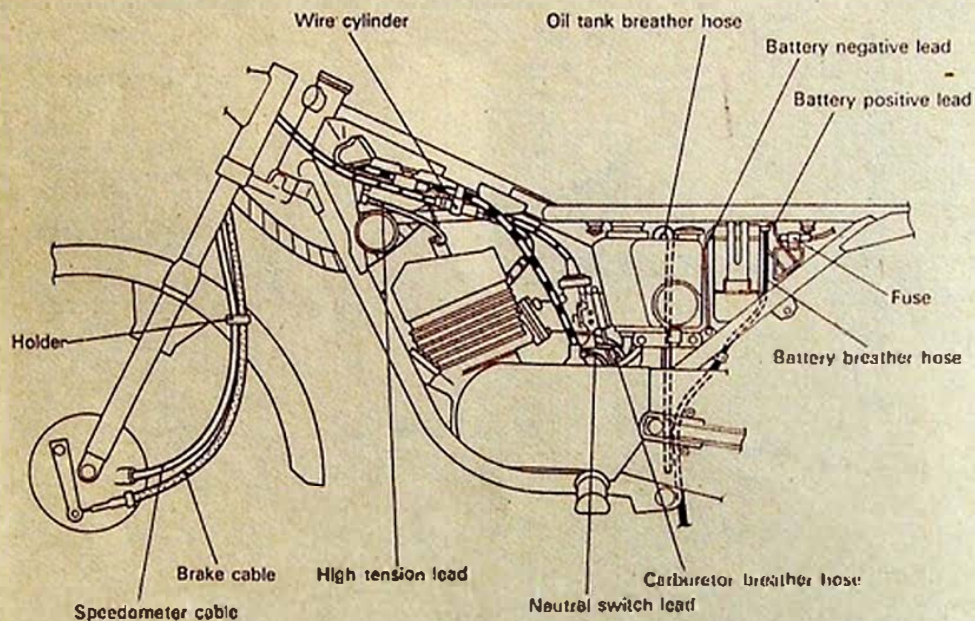
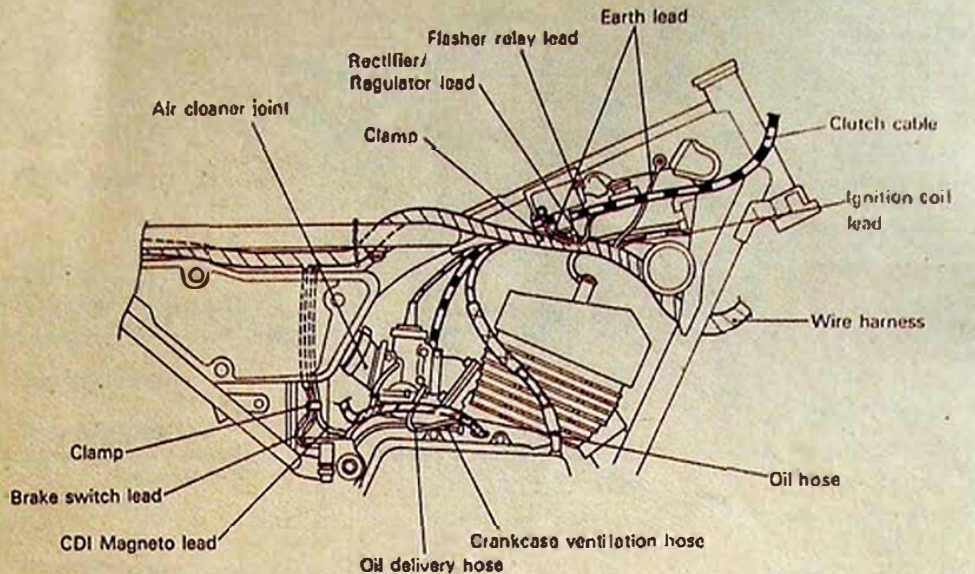

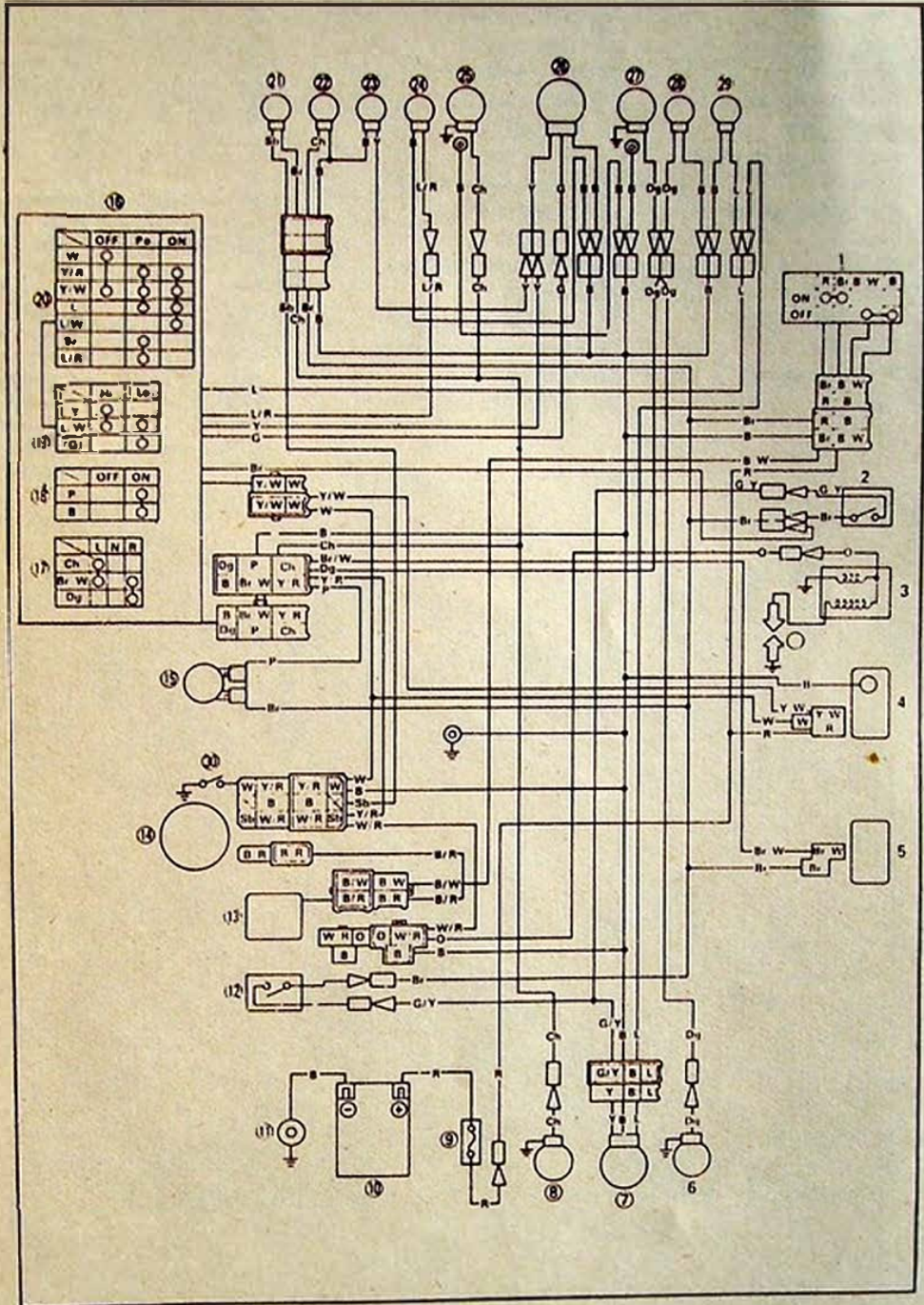

WIRING DIAGRAM

- ① Main switch
- ② Front brake switch
- ③ Ignition coil
- ④ Rectifier/Regulator
- ⑤ Flasher relay
- ⑥ Rear flasher light (right)
- ⑦ Tail light
- ⑧ Rear flasher light (Left)
- ⑨ Fuse
- ⑩ Battery
- ⑪ Body earth
- ⑫ Rear Brake switch
- ⑬ CDI unit
- ⑭ Flywheel magneto
- ⑮ Horn

- ⑯ Handlebar switch
- ⑰ Flasher switch
- ⑱ Horn switch
- ⑲ Dimmer switch
- ⑳ Light switch
- ㉑ Neutral light
- ㉒ Flasher Indicator (left)
- ㉓ High beam Indicator
- ㉔ Park light
- ㉕ Front flasher light (left)
- ㉖ Headlight
- ㉗ Front flasher light (right)
- ㉘ Flasher Indicator (right)
- ㉙ Meter light
- ㉚ Neutral light switch

- B Black
- Br Brown
- Ch Chocolate
- Dg Dark green
- G Green
- L Blue
- P Pink
- R Red
- Sb Sky blue
- W White
- Y Yellow
- O Orange
- B/R Black/Red
- B/W Black/White
- Br/W Brown/White
- W/R White/Red
- Y/R Yellow/Red
- Y/W Yellow/White
- L/W Blue/White
- L/R Blue/Red
- G/Y Green/Yellow



1. ELECTRICAL SYSTEM ENGINE TROUBLESHOOTING

•CHECK ALL WIRES CONNECTIONS.

MAIN SWITCH

•Main Switch is Shorted

IGNITION COIL

•Primary or Secondary Windings are Broken or Faulty.
•High Tension Lead is Faulty.
•Plug Cap is Faulty.

SPARK PLUG

•Many Carbon Deposits.
•Electrodes are Wet.
•Improper Gap.
•Broken.

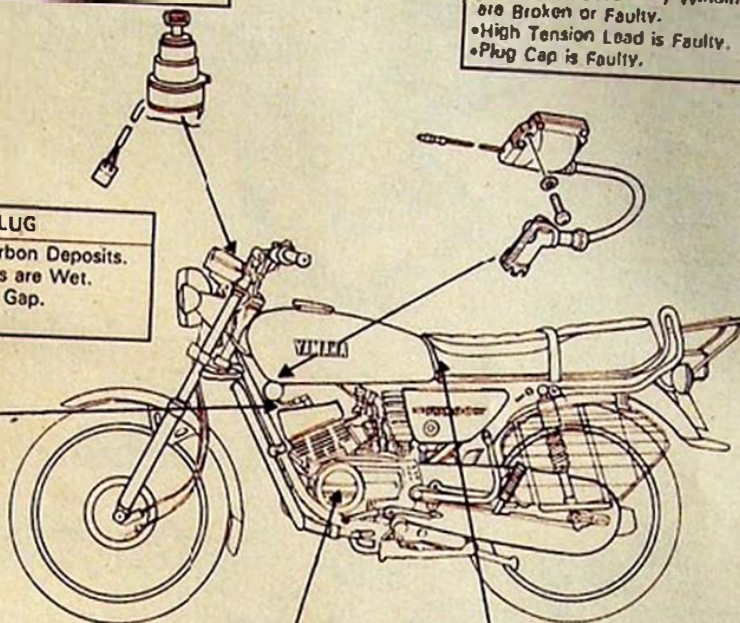
**C.D.I. UNIT**

•Faulty

PICKUP COIL

•Windings are broken.

SOURCE COIL

•Windings are Broken.



2. COMPRESSION SYSTEM

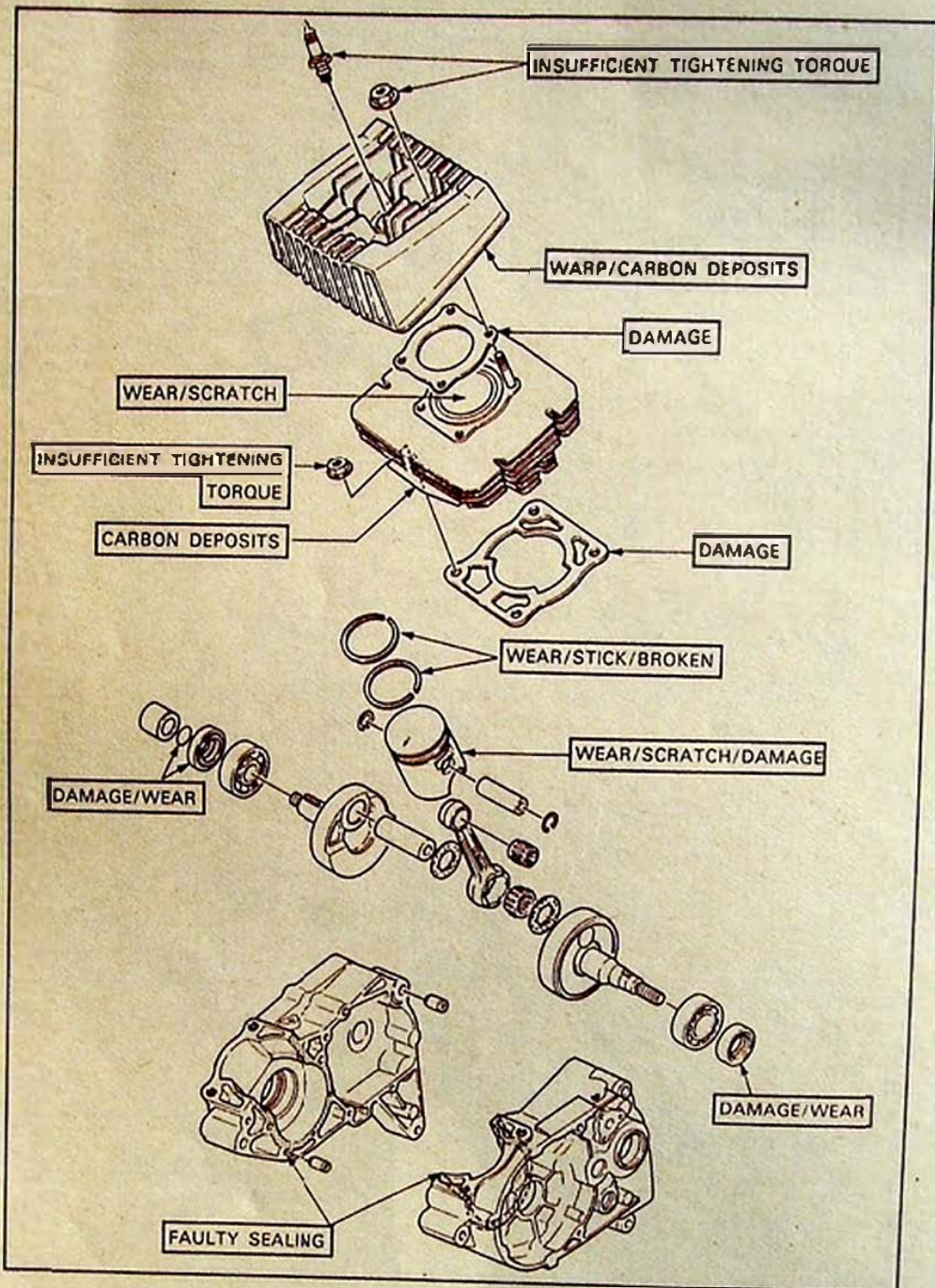



3. INTAKE AND EXHAUST SYSTEMS

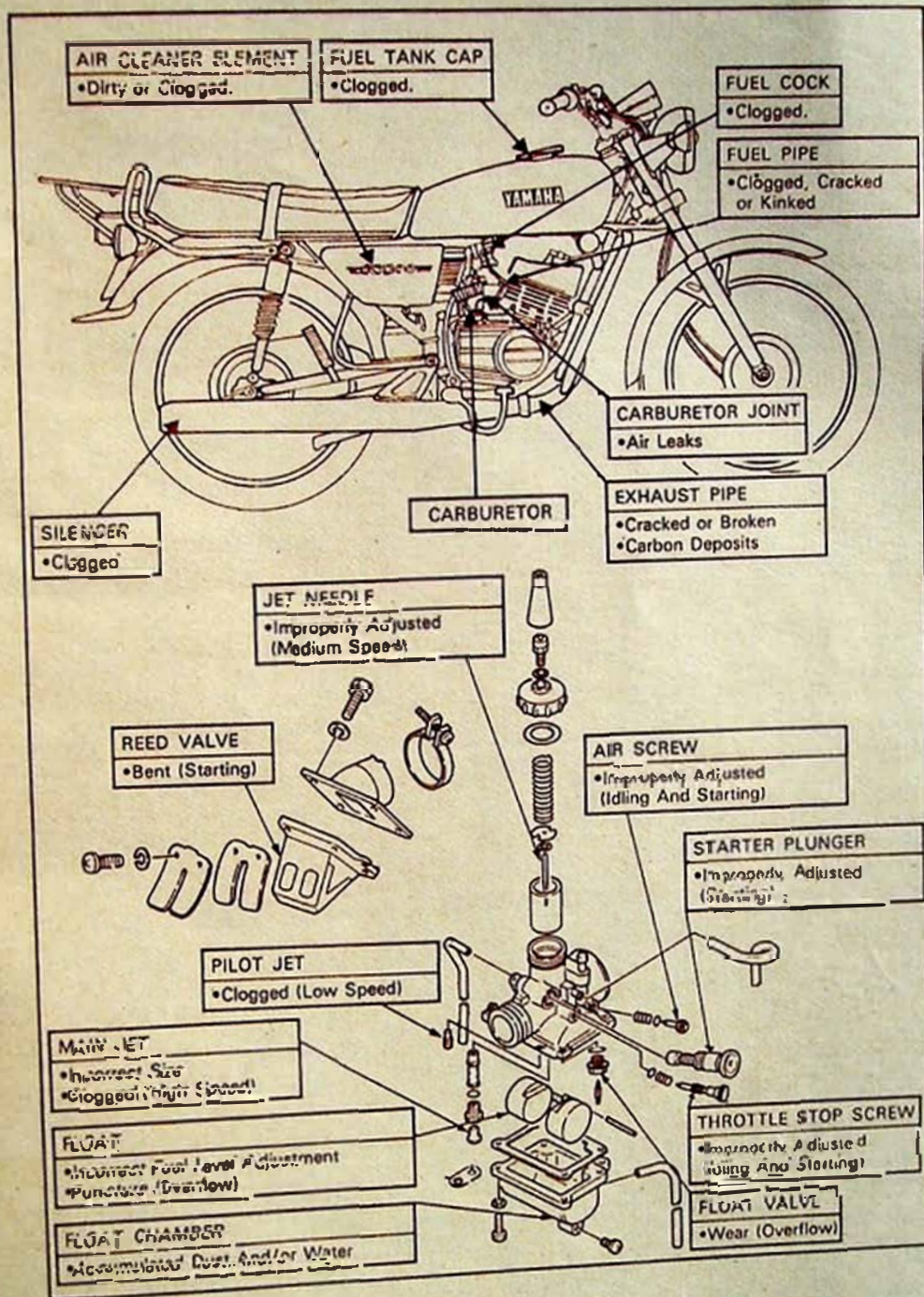



SPECIFICATIONS

Model	RX 100
Transmission: Primary Reduction System Primary Reduction Ratio Secondary Reduction System Secondary Reduction Ratio Transmission Type Operation Gear Ratio 1st 2nd 3rd 4th	Helical gear 74/19 (3.895) Chain Drive 39/15 (2.600) Constant mesh, 4-speed Left foot operation 35/11 (3.182) 30/15 (2.000) 28/19 (1.388) 23/23 (1.000)
Chassis: Frame Type Caster Angle Trail	Double cradle 27.5° 90 mm
Tyre Type Size (F) Size (R)	With lube 2.50-18-4PR 2.75-18-8PR
Tyre Pressure (Cold tyre): Single rider (Front) (Rear) Double Rider (Front) (Rear) Maximum Load *	1.5 kg/cm ² (22 psi) 2.0 kg/cm ² (28 psi) 1.5 kg/cm ² (22 psi) 2.3 kg/cm ² (32 psi) *182kg Max Load is the total weight of cargo, rider, passenger, and accessories
Brake: Front Brake Type Operation Rear Brake Type Operation	Drum brake (130 φ) Right hand operation Drum brake (130 φ) Right foot operation
Suspension: Front Suspension Rear Suspension	Telescopic fork (Japanese Kayaba) Swing arm (Adjustable 5 Positions)
Shock Absorber: Front shock Absorber Rear Shock Absorber	Coil spring, Oil damper Coil spring, Oil damper
Wheel Travel: Front Wheel Travel Rear Wheel Travel	110 mm 75 mm
Electrical: Ignition System Generator System Battery Capacity	C.D.I. Magneto Flywheel magneto 8V 4AH



SPECIFICATIONS



APPX

7

Model	RX 100
Headlight Type:	Semi-sealed beam
Bulb Wattage/Quantity: Headlight Tail/Brake light Flasher light Park light	6V. 25W/25W-1 6V. 5/18 W-1 6V. 10W-4 6V. 3W-1
Indicator Light Wattage/Quantity: "NEUTRAL" "HIGH BEAM" "TURN" Meter light	6V. 3W-1 6V. 3W-1 6V. 3W-2 6V. 3W-1

B. MAINTENANCE SPECIFICATIONS ENGINE

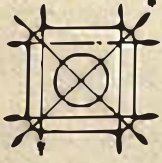
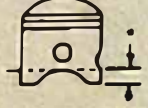
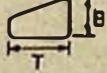

Model	RX 100				
Cylinder Head: Warp Limit 	$< 0.03 \text{ mm}$ * Lines indicate straightedge measurement				
Cylinder: Bore Size Taper Limit Out of Round Limit	$50.0 \pm 0.03 \text{ mm}$ $< 0.05 \text{ mm}$ $< 0.01 \text{ mm}$				
Piston: Piston Size Measuring Point* 	$50.0 \pm 0.03 \text{ mm}$ 10 mm				
Piston Clearance Oversize 1st 2nd 3rd 4th Piston Pin Offset	$0.030 - 0.038 \text{ mm}$ 50.25 mm 50.50 mm 50.75 mm 51.00 mm 0 mm (0 in)				
Piston Ring: Sectional Sketch 	<table border="0"> <tr> <td>Top Ring</td> <td>Keystone B = 1.2 mm T = 2.0 mm</td> </tr> <tr> <td>2nd Ring</td> <td>Keystone B = 1.2 mm T = 2.0 mm</td> </tr> </table>	Top Ring	Keystone B = 1.2 mm T = 2.0 mm	2nd Ring	Keystone B = 1.2 mm T = 2.0 mm
Top Ring	Keystone B = 1.2 mm T = 2.0 mm				
2nd Ring	Keystone B = 1.2 mm T = 2.0 mm				

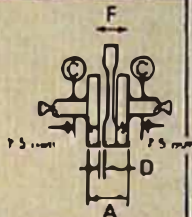
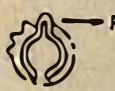

Model		RX 100
End Gap (Installed)	Top Ring	0.15 - 0.35 mm
	2nd Ring	0.15 - 0.35 mm
Side Clearance (Installed)	Top Ring	0.03 - 0.05 mm
	2nd Ring	0.03 - 0.05 mm
Crankshaft 		
Crank Width "A"		55.9 ± 0.05 mm
Run Out Limit "B"		< 0.03 mm
Connecting Rod Big End Side Clearance "C"		0.2 - 0.7 mm
Small End Free Play Limit "F"		< 2.0 mm
Clutch		
Friction Plate Thickness/Quantity		3.0 mm × 5
Wear Limit		< 2.7 mm
Clutch Plate Thickness/Quantity		1.2 mm × 4
Warp Limit		< 0.05 mm
Clutch Spring Free Length/Quantity		34.5 mm × 4
Clutch Spring Minimum Length		< 33.0 mm
Clutch Release Method		Inner push. Screw push
Push Rod Bending Limit		< 0.15 mm
Transmission:		
Main Axle Deflection Limit (Runout)		0.1 mm
Drive Axle Deflection Limit (Runout)		0.1 mm
Shifter:		
Shifting Type		Guide bar
Guide Bar Bending Limit		< 0.05 mm
Kick Starter Type:		Kick and mesh type
Kick Clip Friction Force		P = 1.0 kg
< Min. - Max. >		< 0.8 - 1.2 kg
		
Air Filter Oil Grade (Oilied Filter):		SAE 30

SPECIFICATIONS

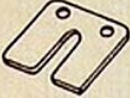

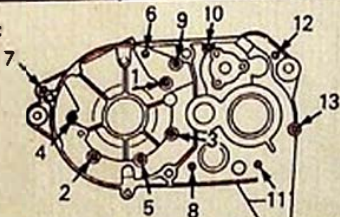
<p>Carburettor: Type/Manufacturer/Quantity 1. K. Mark Main Jet (M.J.) Air Jet (A.J.) Jet Needle-clip Position (J.N.) Needle Jet (N.J.) Cutaway (C.A.) Pilot Jet (P.J.) Pilot Air Screw (P.A.S.) Starter Jet (G.S.) Float Height (F.H.) Engine Idling Speed</p>	<p>VM20/MIKUNI/1 1L100 # 115 Ø 1.0 4M2-3 N-8 2.0 # 20 1-1/4 ± 1/2 # 30 21.0 ± 1.0 mm 1200 ± 50 r/min</p>
<p>Reed Valve: Valve Stopper Height Reed Bending Limit</p>	<div style="display: flex; align-items: center;">  <p>9 mm 0.3 mm</p> </div>
<p>Lubrication System: Autolube Pump-Color Code Minimum Stroke Maximum stroke Pully Adjusting Mark At Idle</p>	<p>Separate lubrication (Yamaha autolube pump) Orange 0.20 — 0.25 mm 1.85 — 2.05 mm</p> <div style="text-align: center;">  </div>
<p>Crankcase Tightening Sequence:</p> <div style="border: 1px solid black; padding: 2px; display: inline-block; margin-bottom: 10px;"> 0.7 m.kg. (5.1 ft. lb) </div>	



SPECIFICATIONS

Tightening Torque	Thread Size	Qty	M kg	ft lb
Cylinder head	M 8x1.25	4	2.5	18
Cylinder	M10x1.25	4	3.5	25
Spark plug	M14x1.25	1	2.0	14
Oil pump	M 5x0.8	2	0.5	3.6
Intake manifold	M 6x1.0	4	0.8	5.7
Crankcase	M 6x1.0	13	0.7	5.1
Crankcase cover	M 6x1.0	11	0.9	6.5
Flywheel cover	M 8x1.0	4	0.8	5.8
Oil pump cover	M 6x1.0	3	0.8	5.8
Drain plug	M12x1.5	1	2.0	14
Kick crank	M 8x1.25	1	2.5	18
Primary drive gear	M12x1.0	1	5.5	40
Clutch boss	M12x1.0	1	4.3	31
Clutch spring	M 5x0.8	4	0.6	4.3
Drive sprocket	M16x1.0	1	5.5	40
Neutral point	M14x1.5	1	2.0	14
Neutral switch	M12x1.5	1	0.4	2.9
Cam stopper	M14x1.5	1	2.0	14
Shift cam stopper lever Use LOCTITE or equivalent	M 8x1.0	1	1.4	10
Change pedal	M 8x1.0	1	1.0	7.0
Change shaft adjuster Use LOCTITE or Equivalent	M 8x1.25	1	3.0	22
Oil seal retainer	M 8x1.25	1	1.6	11
Flywheel magneto	M12x1.25	1	7.0	50
Stator	M 8x1.0	2	0.7	5.1



SPECIFICATIONS



Model	RX 100
Steering System: Steering Bearing Type No./Size of Steel Balls Upper Lower	Ball Bearing 22 pcs (3/16 in) 19 pcs (1/4 in)
Front Suspension: Front Fork Travel Fork Spring Free Length Limit	110 mm 298.5 mm 291.5 mm
Oil Capacity Oil Grade	175 ± 3CC Servo teleshocab oil
Rear Suspension: Shock Absorber Travel	70 mm
Rear Arm: Swing Arm Free Play Limit End (Skew) Side	<2 mm <2 mm
Wheel: Front Wheel Type Rear Wheel Type Front Rim Size/Material Rear Rim Size/Material Rim Runout Limit Vertical Lateral	Spoke Wheel Spoke Wheel 1.50 × 18/Steel 1.50 × 18/Steel <2 mm <2 mm





SPECIFICATIONS

Model	RX 100
Drive Chain Number of Links Chain Slack	110 links 20 — 30 mm
Drum Brake Type Drum Inside Dia. < Limit > Lining Thickness < Limit >	Loading and trailing 130 mm < 131 mm 5.0 mm < 2.0 mm
Brake Lever & Brake Pedal: Brake Lever Free Play/position Brake Pedal Free Play/position	5 — 8 mm/at lever pivot. 20 — 30 mm/15 mm (Vertical height below footrest top.)
Clutch Lever Free Play/position	2 — 3 mm/At lever pivot



SPECIFICATIONS



Tightening Torque	Thread Size	Qty	m.kg	ft.lb)
Front axle shaft	M10×1.25	1	4.3	31
Crown handle-Inner tube	M 8×1.25	2	1.5	11
Crown handle-Steering shaft	M10×1.25	1	4.0	29
Handle crown-Handle holder	M 8×1.25	4	1.9	13
Under bracket-Inner tube	M10×1.25	2	3.0	22
Pivot shaft	M12×1.25	1	6.0	43
Tension bar	M 8×1.25	2	1.9	13
Sprocket (Rear)	M 8×1.25	4	2.6	18
Camshaft lever	M 8×1.0	2	0.9	6.5
Rear axle shaft	M14×1.5	1	9.2	66
Sprocket shaft nut	M20×1.0	1	9.2	66
Shock absorber	M10×1.25	2	4.0	29
Front engine mounting bolt	M 8×1.25	1	3.0	22
Rear upper engine mounting bolt	M10×1.25	1	6.0	43
Rear lower engine mounting bolt	M10×1.25	1	6.0	43
Footrest-Frame	M 8×1.25	4	2.3	17
Cap Bolt-Front fork	M25×1.0	2	2.3	17