

GENUINE

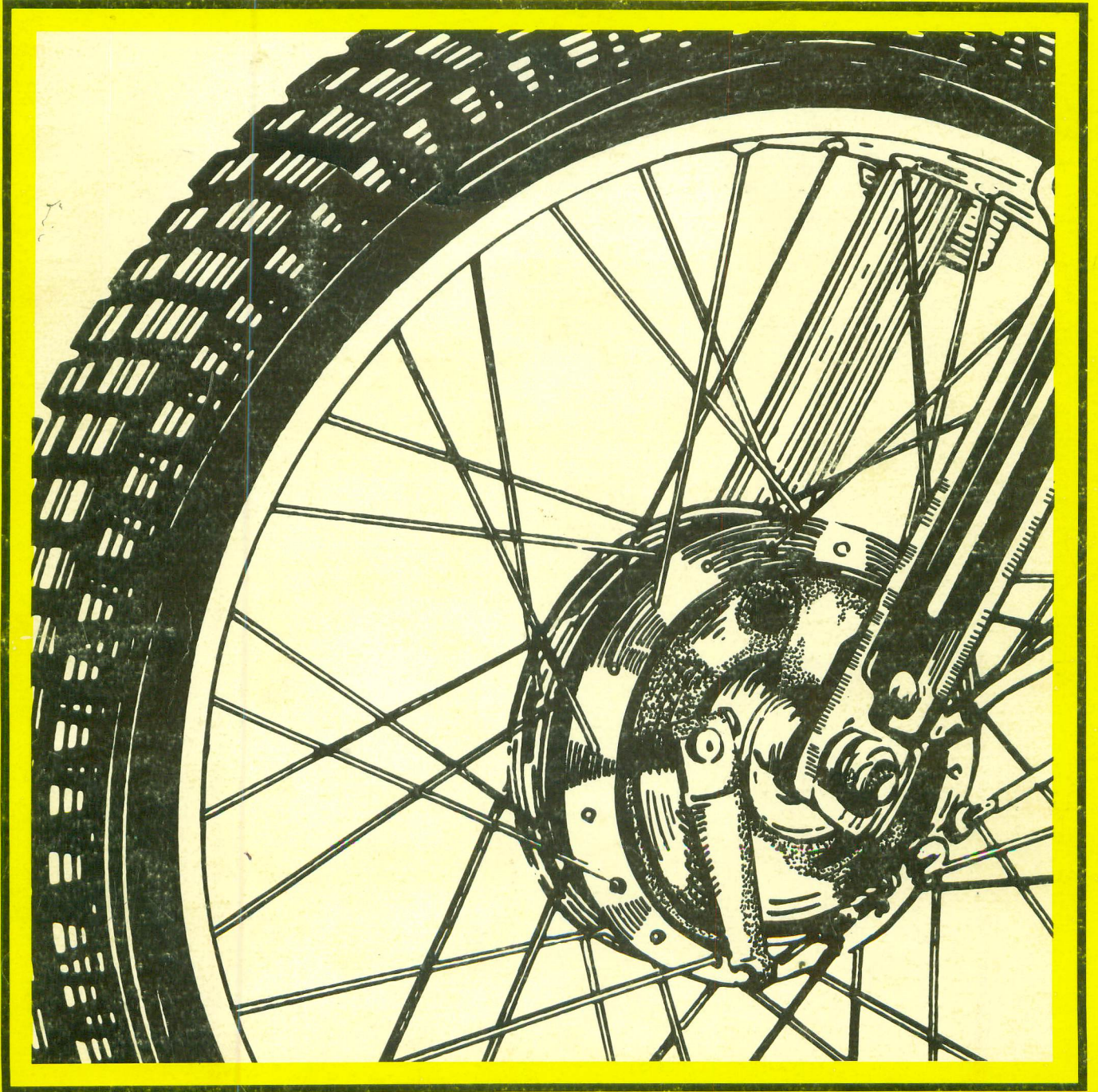

MONOCROSS SUSPENSION Service Manual



- SPECIFICATIONS
- EXPLODED VIEWS
- RECOMMENDED MAINTENANCE
- TUNE-UP AND OVERHAUL PROCEDURES

LIT-11613-52-02



YAMAHA MOTOR CO.,LTD.

INDEX

FEATURES

1

CONSTRUCTION

2

COMPONENTS

3

OPERATION

4

INSPECTION & MAINTENANCE

5

SPECIAL TOOLS

6

DISASSEMBLY

7

REASSEMBLY

8

TUNING

9

FEATURES

The primary advantages of the Monocross Suspension System are greater rear wheel travel and increased stability. A conventional dirt bike with standard shock absorbers will have approximately 3¾" of rear wheel travel. The Monocross system is capable of over 6¼" of rear wheel travel; 2½" greater than the conventional system. Because the damper is attached to the frame close to the head pipe, frame flexing at the swing arm is virtually eliminated. The shock pulse is transmitted to the head pipe area of the frame, a very strong area capable of absorbing this kind of force. Another feature of the Monocross which increases stability is that it is made up of a single cushion unit rather than the conventional double cushion system. This means greater rigidity with no lateral movement of the frame due to uneven spring and damping constants between the right and left sides.

The combined use of nitrogen gas, rubber damper, oil and coil spring assures the rider of better riding comfort. Being filled with high pressure nitrogen gas, the Monocross suspension unit is free from oil cavitation within the cylinder. In other words, damping efficiency is not affected by air bubbles in the oil. Also, due to high pressure nitrogen gas, the Monocross suspension does not compress when the rider sits astride the machine. This allows greater effective rear wheel travel when the machine is in operation on the race course.

CONSTRUCTION

The Monocross shock absorber is attached to the frame behind the head pipe (Figure 1, see a.) with the attaching member sandwiched between two rubber dampers. The other end of the shock absorber is attached to the top end of the swing arm (Figure 1, see b.). The unit is filled with oil, pressurized with nitrogen and cushioned by the rubber dampers and coil spring.

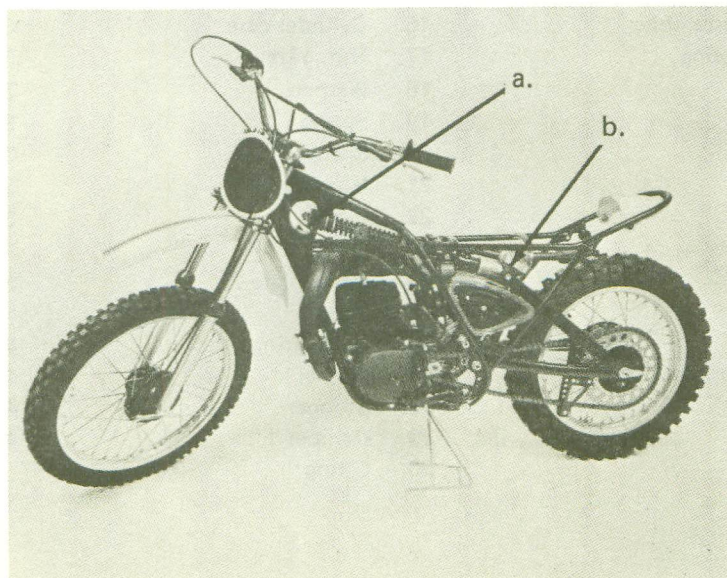

Figure 1

COMPONENTS

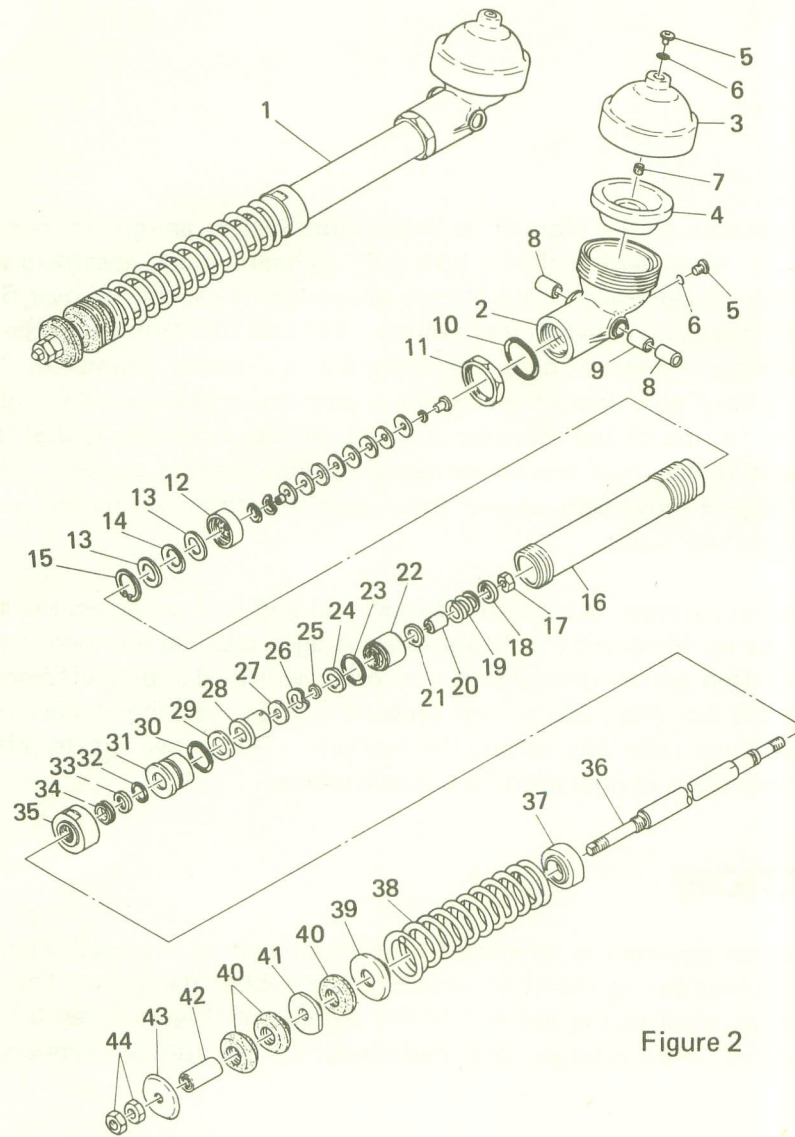
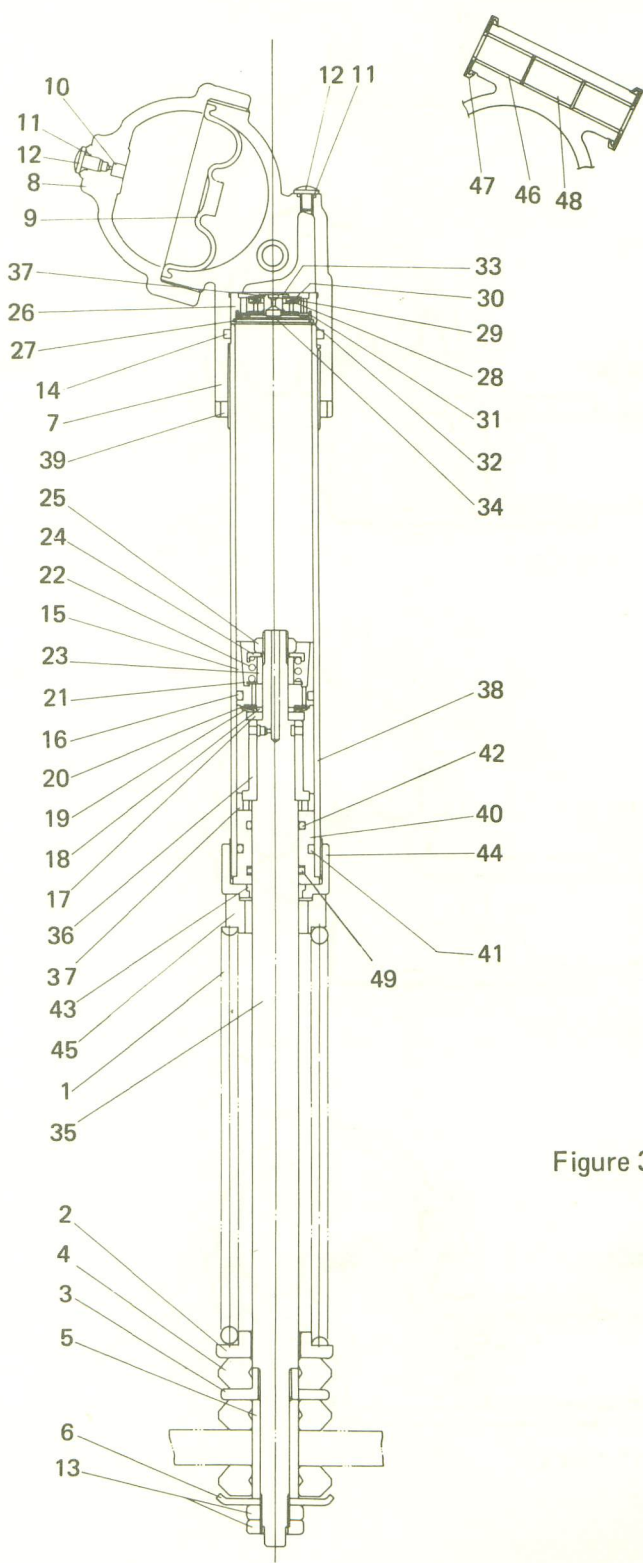

Figure 2

- | | | |
|--------------------------|-------------------|------------------------|
| 1. Rear cushion assembly | 16. Cylinder case | 31. Seal housing |
| 2. Membrane housing | 17. Nut, 17mm | 32. O-ring |
| 3. Housing cap | 18. Washer | 33. Seal |
| 4. Membrane | 19. Spring | 34. Ring seal |
| 5. Blind screw | 20. Spacer | 35. Case cap |
| 6. O-ring | 21. Valve plate 1 | 36. Piston rod |
| 7. Valve rubber | 22. Piston | 37. Spring seat, lower |
| 8. Bushing | 23. O-ring | 38. Spring |
| 9. Collar | 24. Valve plate 2 | 39. Spring seat, upper |
| 10. O-ring | 25. Spacer | 40. Damper 2 |
| 11. Ring nut | 26. Leaf spring | 41. T-nut |
| 12. Base valve assembly | 27. Washer | 42. Distance collar |
| 13. Valve plate 3 | 28. Stopper | 43. Plate 1 |
| 14. Leaf spring 2 | 29. Damper 1 | 44. Nut, 23mm |
| 15. Circlip | 30. O-ring | |

- 1. Spring
- 2. Spring seat, upper
- 3. T-nut
- 4. Damper 2
- 5. Distance collar
- 6. Plate 1
- 7. Membrane housing
- 8. Housing cap
- 9. Membrane
- 10. Valve rubber
- 11. O-ring
- 12. Blind screw
- 13. Nut
- 14. O-ring
- 15. Piston
- 16. O-ring
- 17. Plate washer
- 18. Spacer
- 19. Leaf spring
- 20. Valve plate 2
- 21. Valve plate 1
- 22. Spring
- 23. Spacer
- 24. Washer
- 25. Nut
- 26. Base valve
- 27. Circlip
- 28. Valve plate 5
- 29. Leaf spring
- 30. Spacer
- 31. Valve plate 3
- 32. Leaf spring
- 33. Valve plate 4
- 34. Center shaft
- 35. Piston rod
- 36. Stopper
- 37. Damper 1
- 38. Cylinder case
- 39. Ring nut
- 40. Seal housing
- 41. O-ring
- 42. O-ring
- 43. Ring seal
- 44. Case cap
- 45. Spring seat, lower
- 46. Bushing
- 47. Thrust cover
- 48. Collar
- 49. Seal



3

Figure 3

OPERATION

1. The gas chamber (shown at left) is pressurized with nitrogen gas. The nitrogen gas is separated from the oil reservoir by a rubber membrane which moves back and forth as the oil moves in and out of the cylinder.

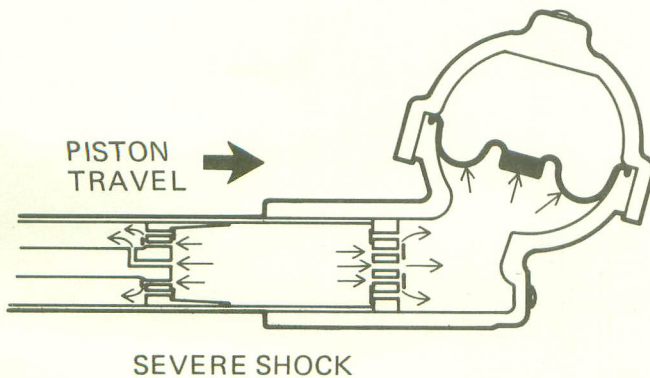
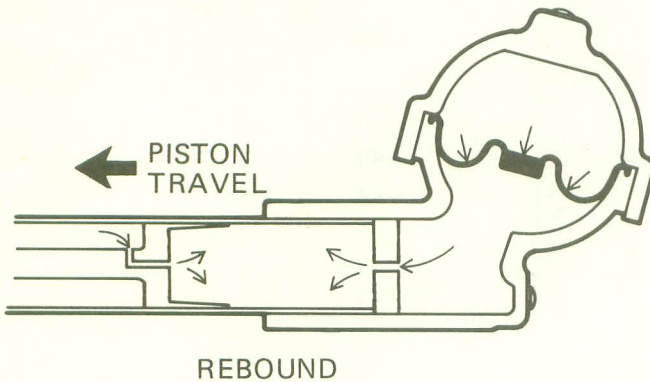
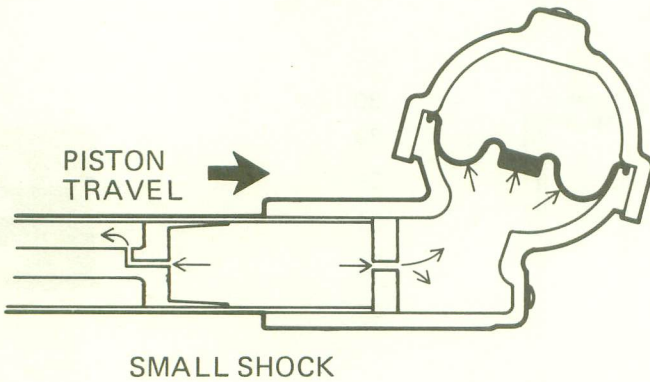
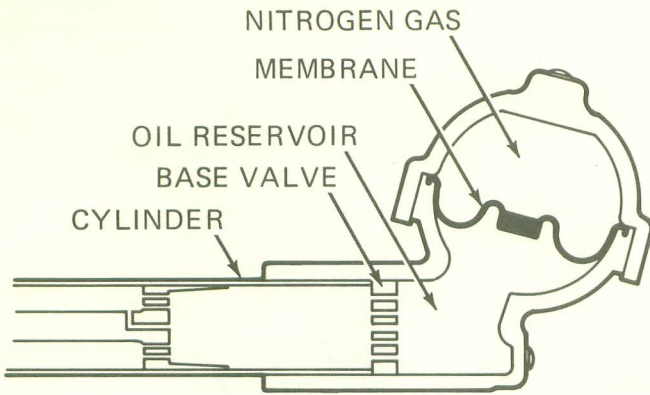

2. When a small shock is encountered by the rear wheel, the piston rod (Figure 3, see No. 35) is forced down into the cylinder housing. Oil is then forced through a metered hole in the piston rod and through the center hole in the base valve. The oil forced through the base valve causes the membrane to move up.
3. After a small shock, the piston rebounds by action of the coil spring and oil flows back through the metered hole in the piston rod. The nitrogen pressure above the membrane forces the membrane down and oil is forced back through the center hole in the base valve.
4. When a severe shock is encountered, the piston rod is forced down into the cylinder at a faster rate than before. The metered holes in the piston rod and base valve are not large enough to allow the oil to flow through adequately. The oil pressure increases and overcomes the force of the leaf springs causing them to open and allow increased oil flow. The membrane is forced up in proportion to the amount of oil forced in by the piston.

5. After a severe shock, the piston rebounds reversing the above action. The compression leaf springs close and the rebound leaf springs open; oil flows back into cylinder. The membrane returns to its original position and oil from the reservoir flows back into the cylinder.

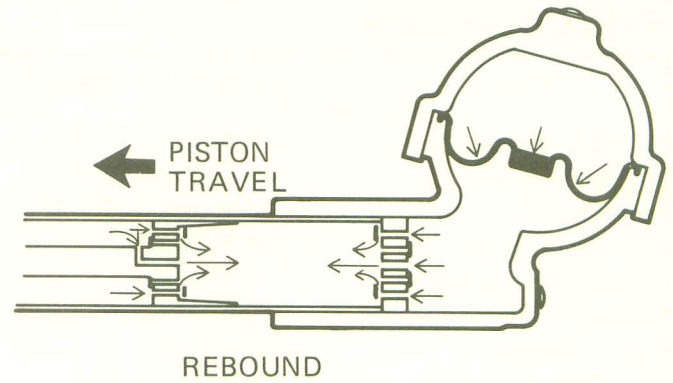

INSPECTION

Remove tank and seat and visually inspect the Monocross Suspension Unit. Oil leakage around the membrane housing and/or the exposed portion of the piston rod is an indication of a faulty seal. Replacement procedures for seals and O-rings are included in this text.

MAINTENANCE

The Monocross Suspension Unit should be removed (see Page 6), cleaned in soap and water and dried after every event. Before cleaning, it is necessary to remove the spring to give clear access to the piston rod. After cleaning the Monocross unit, the case cap seal should be greased (see Page 15, No. 35).

In order for the Monocross Suspension Unit to function properly, it is necessary for periodic inspection and maintenance according to the following table. This table should be considered strictly as a guide to inspection and maintenance intervals. Weather, terrain and individual use all tend to demand that each owner alter the maintenance schedule to match his environment.

PAGE	ITEM	EVENT INTERVAL	
		After Every Event	After Every 8 Events
5	INSPECT	X	
5	CLEAN	X	
15	CHECK LEAKAGE	X	
	REPLACE:		
	O-rings & seals		X
	Oil		X
15	Nitrogen gas		X

4

5

SPECIAL TOOLS

ITEM	PART NUMBER
a. Rear arm holder	908-90910-41-00
b. Regulator	908-90910-28-00
c. Regulator hose	908-90910-30-00
d. Check gauge	908-90910-31-00
e. Needle adaptor	908-90910-29-00
f. Injector	908-90011-53-00
g. Strap wrench	Available on market
h. Ring nut wrench	908-90011-55-00
i. Seal housing insertion tool	908-90011-59-00

NECESSARY SUPPLIES

- a. Compressed Nitrogen Gas
(available at welding supply stores)
- b. Fork and shock fluid
- c. All-purpose grease
- d. Clean, lint-free rags or paper towels

--- WARNING ---

Use only nitrogen to pressurize the gas chamber on the Monocross Suspension System. The use of any other gas can cause an explosion within the damper unit resulting in serious injury to anyone in the area.

DISASSEMBLY

--- CAUTION ---

The work area where the Monocross is to be disassembled should be as clean as possible to assure satisfactory operation after the unit is reassembled. Any dirt or other contamination in the unit will cause poor performance and the Monocross will have to be disassembled again.

1. Remove the seat, both side covers, the mud shrouds above the air cleaner and the fuel tank.
2. Prop the bike up so that there is no weight on the rear wheel. With a 23mm wrench, remove the double nuts at the front of the suspension unit and the rubber damper. With a 13mm wrench remove the bolt at the rear. Pull the suspension unit to the rear and remove it.
3. Install the rear arm holder in the place of the suspension unit. Fasten the rear portion of the holder, using the bolt previously removed from the Monocross. Slip the holder into the front mount and fasten with a spring clip or cotter pin. Installation of this bar allows the machine to be moved while the suspension unit is removed.

--- CAUTION ---

The rear arm holder is designed to hold the weight of the machine only. Do not sit on or attempt to operate the machine with the holder in place.

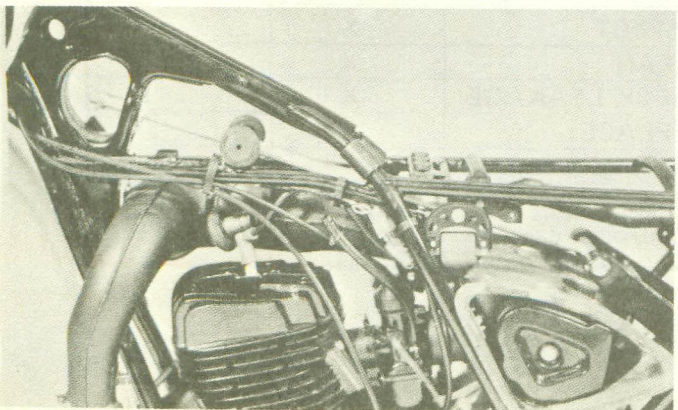
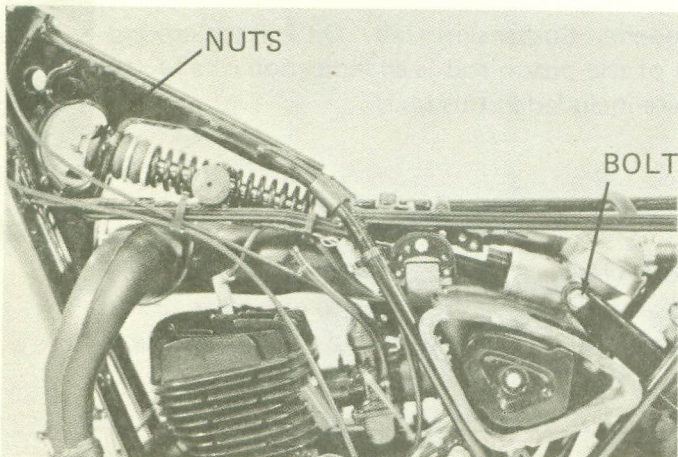

4. Remove the remaining rubber dampers and bushing from the front of the Monocross and inspect them for wear and damage.

--- CAUTION ---

Never clamp the cylinder case in the vise jaws.

5. Clean the Monocross unit thoroughly of all exterior dirt and clamp the housing at rear mounting boss securely in a vise. Use a piece of inner tube or other protective material over the vise jaws.

6. Remove the T-nut, third rubber damper, upper spring seat, spring and lower spring seat from the unit.
7. Turn the housing in the vise until the housing cap faces up. With a Phillips head screwdriver, remove the blind screw from the housing cap.

8. Lightly oil the injector needle and insert it into the rubber valve in the housing cap. Remove needle after the nitrogen gas has escaped.

--- CAUTION ---

The nitrogen gas in the Monocross is under high pressure and must be bled off. Attempting to remove the housing cap while it is still pressurized would be dangerous and could result in injury.

9. Clamp the housing cap lightly in the vise. Grasp the cylinder and loosen the housing cap. Turn the unit right side up and remove the cap.

NOTE: There is oil inside the housing. Be careful not to spill it.

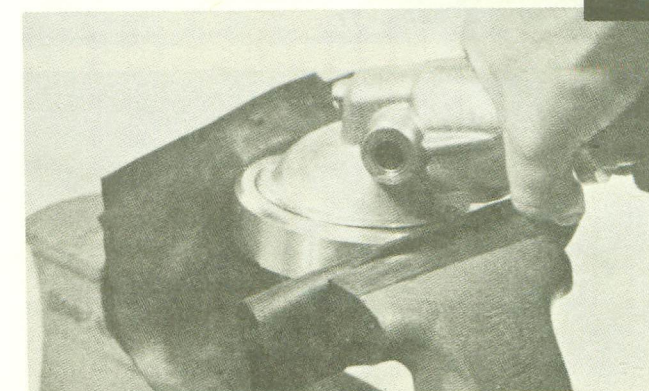
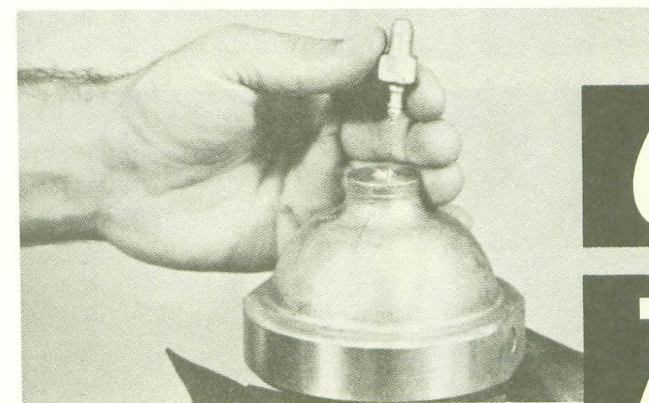
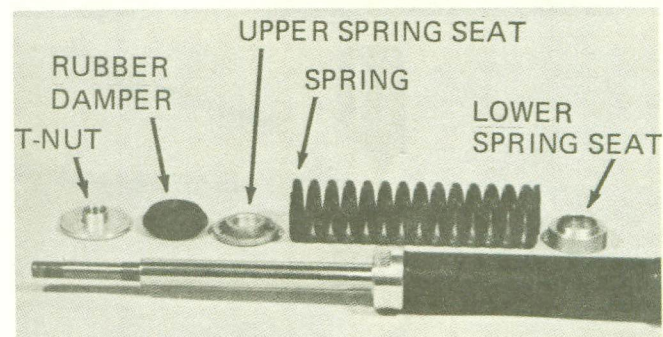
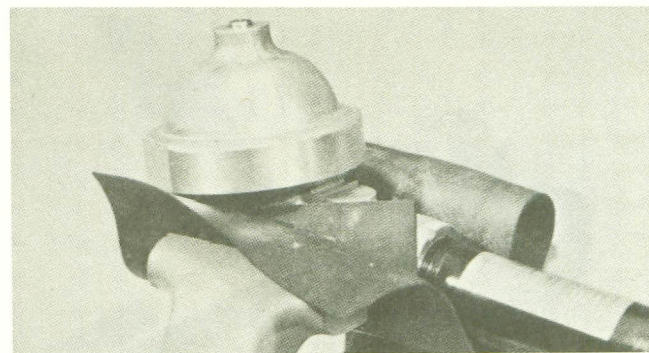
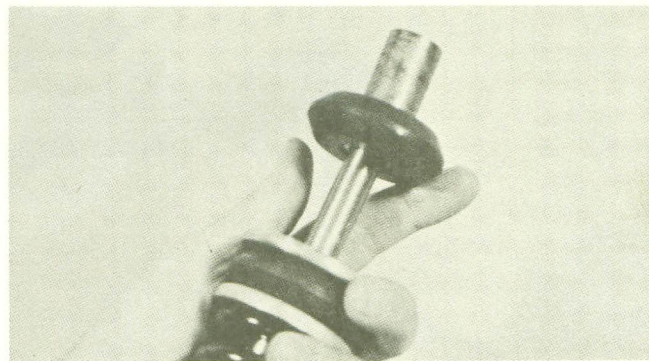

6

7

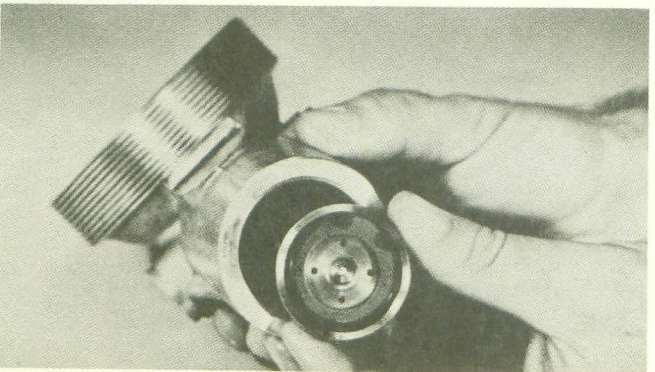
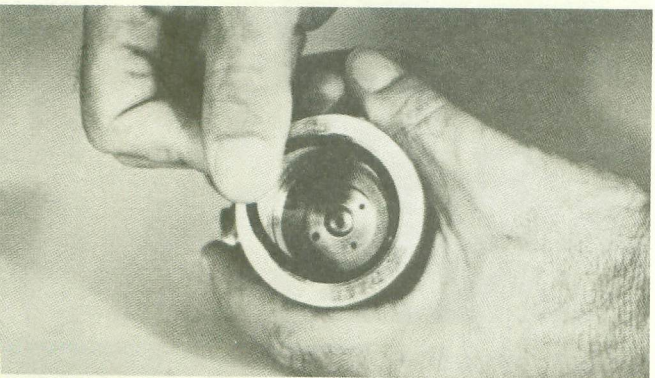
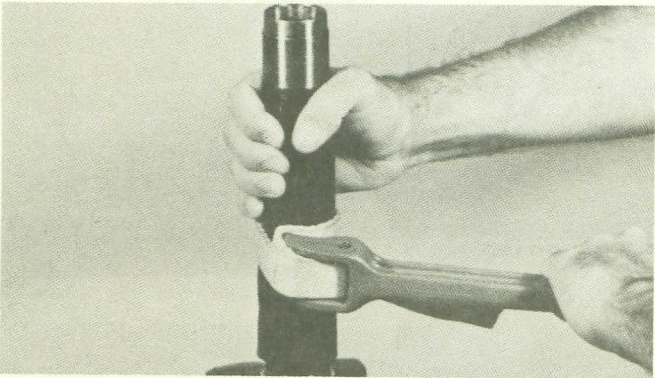
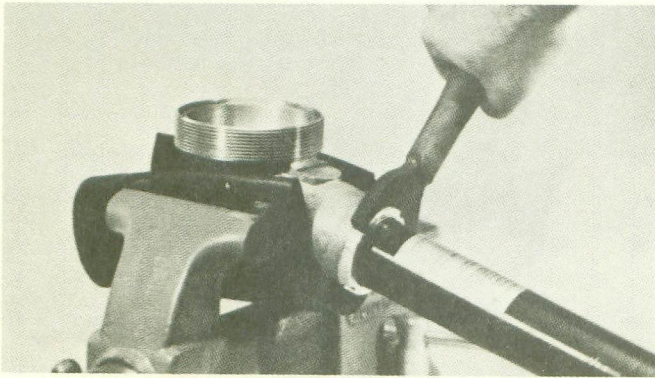
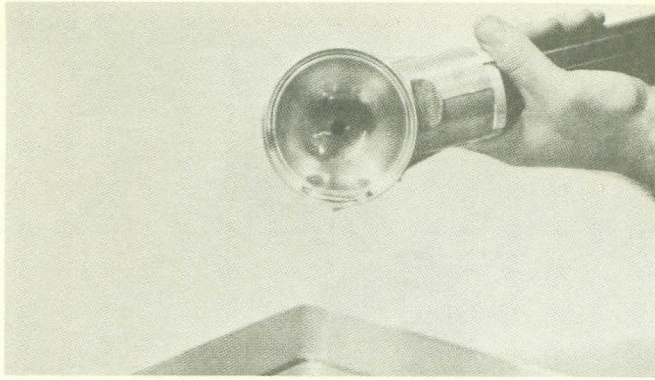

10. Remove the membrane from the housing. Take care not to damage the sealing edge of the membrane when removing it. The oil can now be emptied from the unit. In a rotating motion, slowly pump the piston in and out to remove all the oil from the cylinder case.
11. Clamp the membrane housing at the rear mounting boss securely in a vise. Using the ring nut wrench, loosen the ring nut which holds the cylinder to the membrane housing. Remove the housing from the cylinder.
12. Push the piston rod assembly out of the cylinder. Handle the piston rod carefully to avoid scratches and nicks on the polished shaft surface.
13. Clamp the case cap in the vise by the flats. Do not clamp the vise too tight. Loosen the cylinder case from the case cap with a strap wrench.
NOTE: If the strap wrench slips, use a rubber inner tube between the cylinder and strap wrench for a better grip.
14. Remove the case cap, ring nut and seal housing from the cylinder case.
15. Remove the rubber O-ring from the housing. Take care not to scratch or damage the O-ring groove.
NOTE: All O-rings and seals should be replaced with new ones for reassembly.
16. Tap the membrane housing lightly on the work bench to remove the base valve. Note that the circlip side of the base valve faces outward.

17. Clamp the piston rod assembly in the vise by the flats provided at the end of the shaft. Take care not to damage the threads. With a 17mm socket wrench, remove the nut on the end of the piston rod.

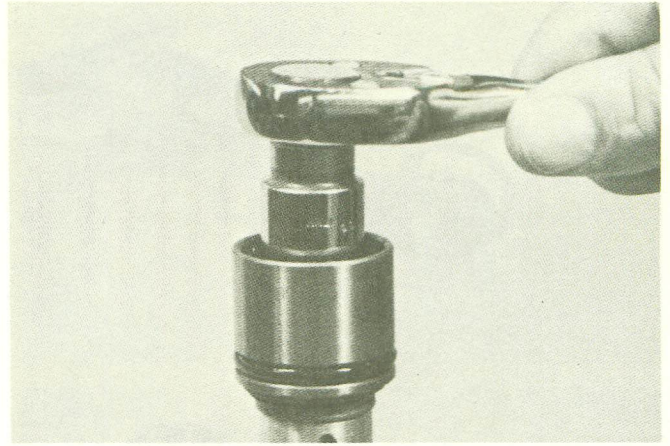

18. Remove piston valve mechanism from piston rod. Check piston lands for defects and dirt. If damage is found, replace piston. Clean piston thoroughly and replace O-ring.

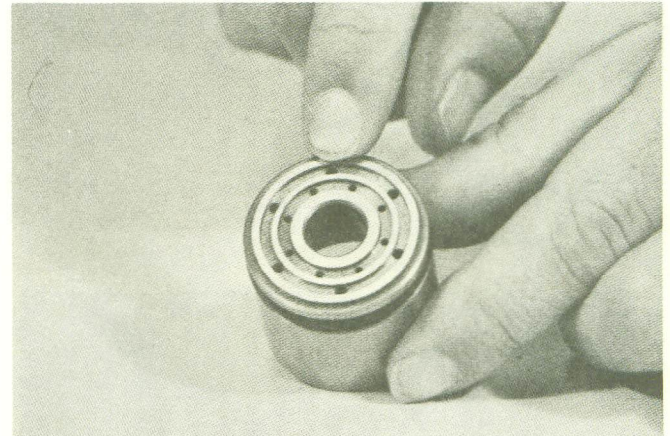

19. Check plate valve for damage. It must be flat to provide a good seal. Inspect the leaf spring for cracks. If cracks are found, replace leaf spring.

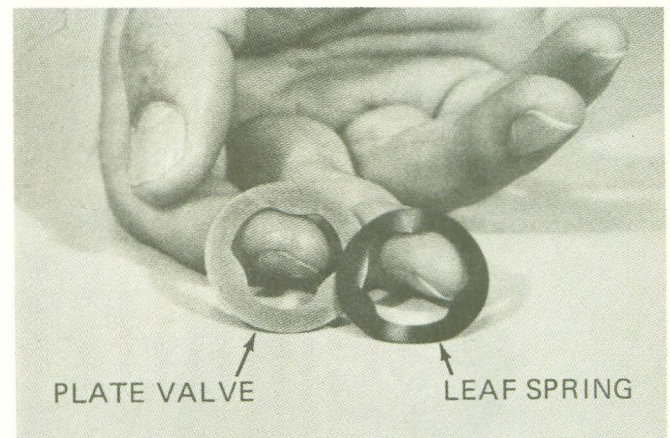

20. Check the surface of the piston rod for scratches or defects. The inner seal slides along the first 140mm from the shoulder. If this portion of the piston rod is scratched or damaged, it should be replaced. Scratches found above this area should be smoothed with 500 grit emery paper, sanding along the length of the rod.

21. Insert a copper wire into oil passages of the piston rod to check for obstructions. Clean the piston rod and blow out passages with compressed air.

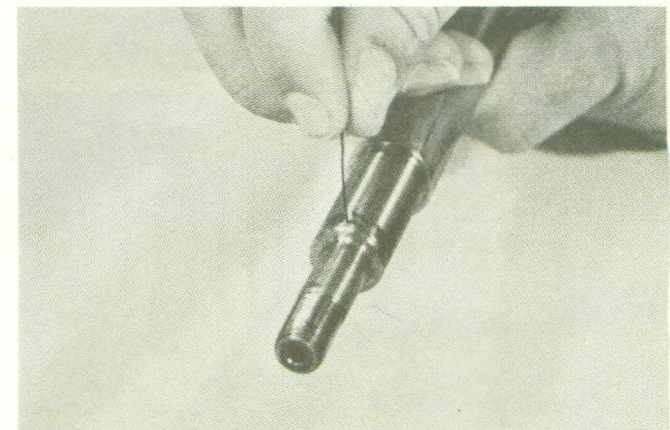

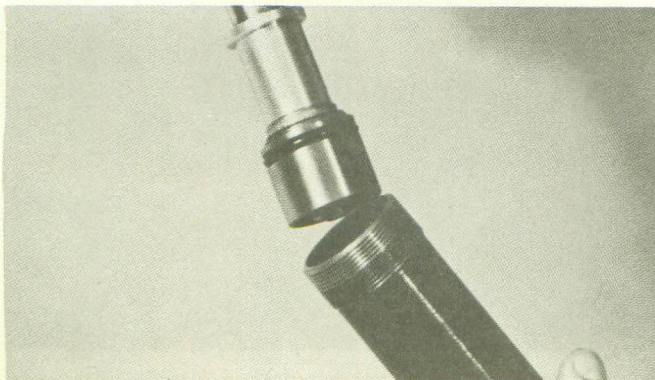
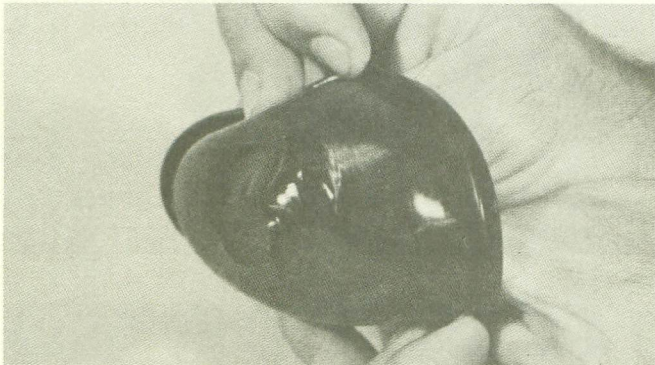
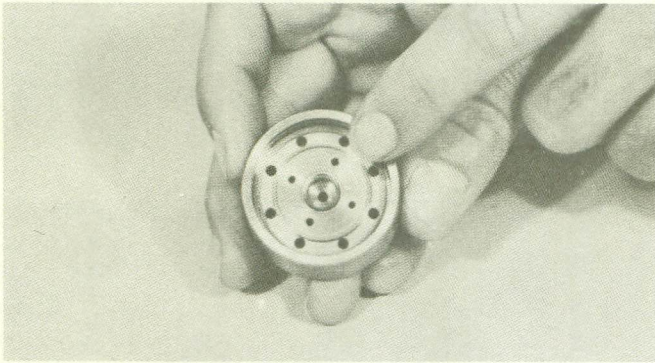
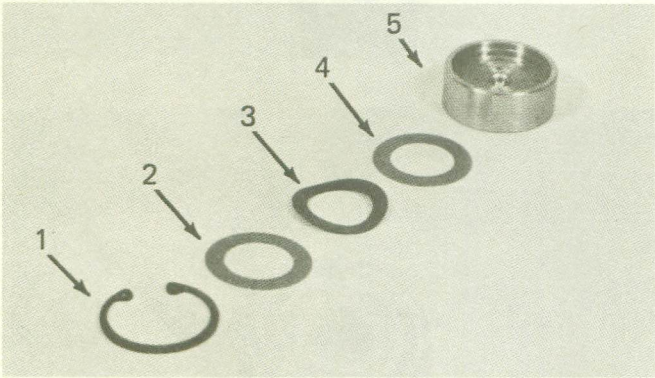
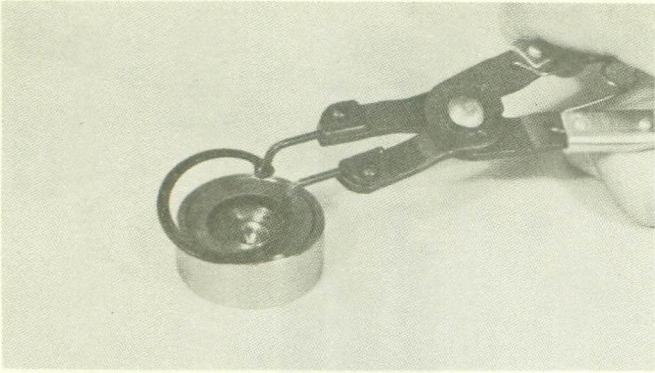

22. Remove snap ring from base valve.

23. The base valve can now be disassembled. The base valve consists of the snap ring (1), plate valve (2), leaf spring (3), another plate valve (4), and the base valve body (5).

24. Inspect the plate valves (2 & 4) for damage and the leaf spring (3) for fatigue cracks.

25. Inspect the lands of the base valve body for pits or damage. If any damage is found, replace valve body. Clean the body and blow off with compressed air.

26. Check the membrane by gently stretching it. Check the sealing edge for nicks or cuts. If membrane is damaged, it must be replaced.

27. The final component for inspection is the cylinder. Inspect cylinder for defects. Check inner wall together with piston for scratches. Small scratches on inner cylinder wall can be smoothed with 500 grit emery paper. If scratches are severe, replace the cylinder.

REASSEMBLY

--- CAUTION ---

It is important that no dirt, dust or other foreign matter be allowed to contaminate the internal components of the suspension unit during reassembly. Use clean paper towels, not shop rags on all internal parts.

1. Reassemble the base valve by installing the plate valve, leaf spring and second plate valve.
2. Complete the assembly of the base valve by installing the snap ring.
3. Place the base valve assembly into the membrane housing with the snap ring side of the valve facing out as shown. Install a new O-ring in the membrane housing and oil thoroughly.
4. Clamp the piston rod in the vise by the flats on the end of the threaded shaft. Install aluminum stopper.
5. Match punch marks on the stopper with marks on piston rod. This alignment allows for proper oil passage.

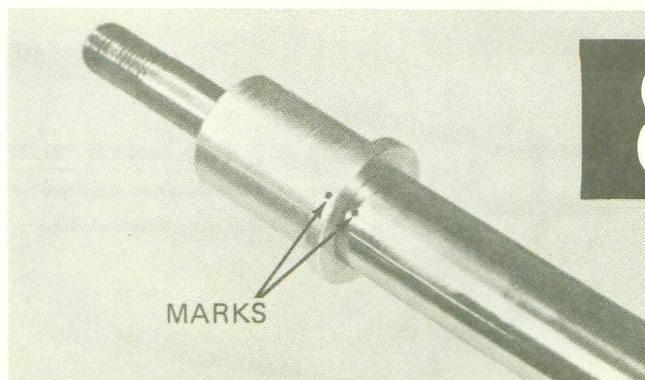
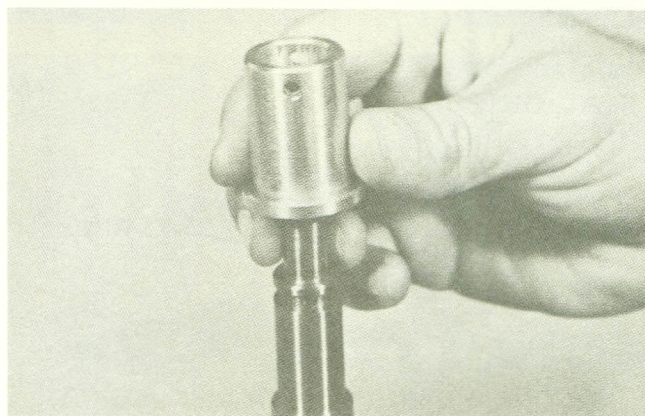
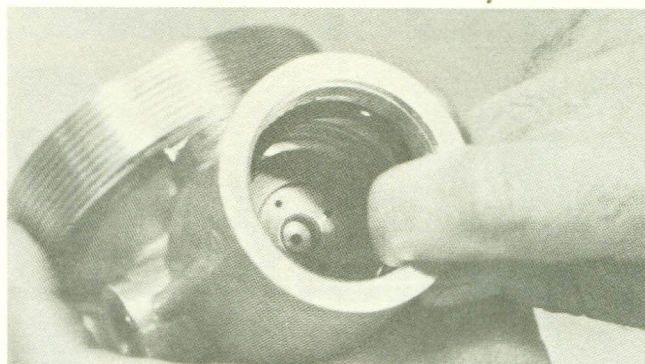
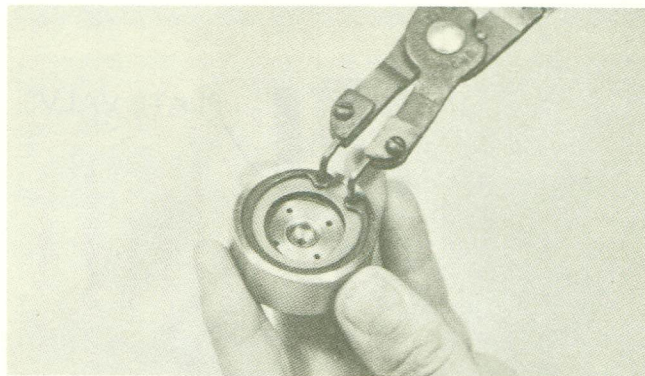

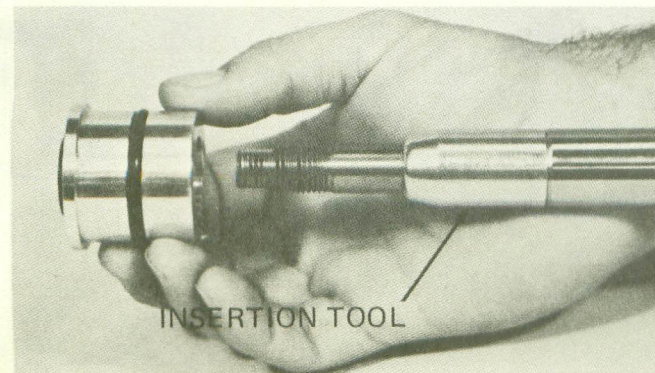
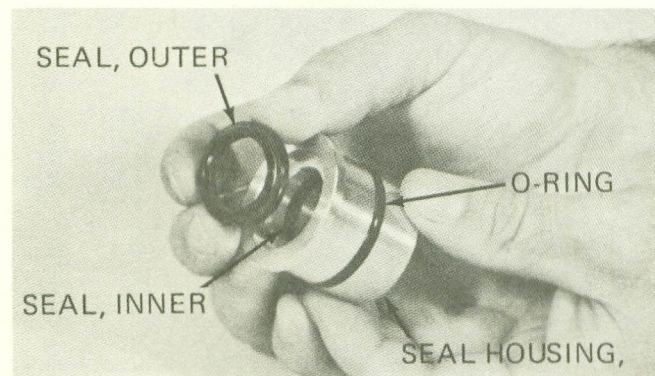
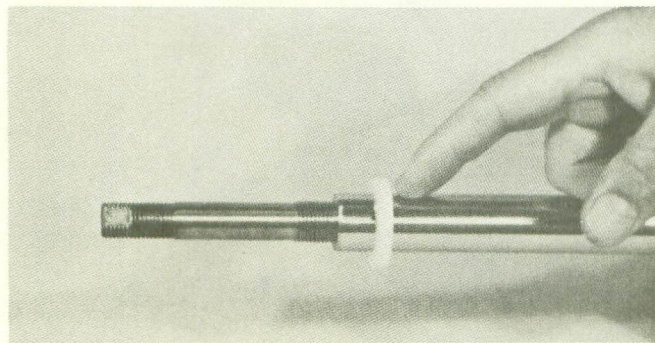
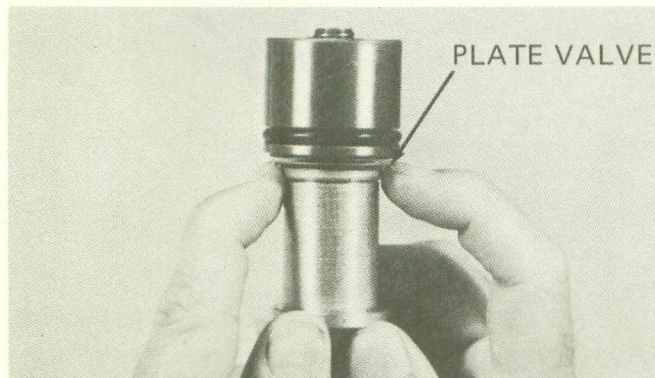
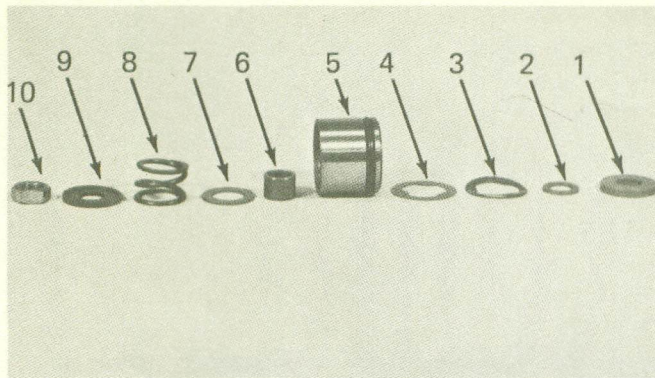

6. Starting from the right, install the large thick washer (1), small diameter washer (2), leaf spring (3), plate valve (4), piston (5), spacer (6), thick plate valve (7), spring (8), spring retainer (9), and 17mm nut on piston rod. Nut should be only finger tight at this time.

7. Before tightening nut, check that the small plate valve is located properly. You should be able to lift it away from the piston clearing all sides. If the plate valve is hung up, loosen the nut and reposition the plate valve. Tighten the 17mm nut.

PISTON ROD NUT TORQUE:
2m-Kg (14.47 ft-lbs.)

8. Oil O-ring on piston liberally. Insert the piston rod assembly into the cylinder using a rotating motion to prevent damage to the O-ring.

NOTE: The piston goes into the end of the cylinder with the least number of threads on its outer diameter.

9. Slide the white nylon washer onto the shaft.

10. Remove and replace the two O-rings and two seals in the seal housing. Lubricate the O-rings and seals with oil.

NOTE: Seal, outer is replaced with the sealing lip forward. Seal, inner is replaced with the sealing lip to the rear.

11. Place the seal housing insertion tool over the end of the piston rod and oil the outer surface of the tool and piston rod. Slide the seal housing over the piston rod and into the cylinder.

12. Remove the insertion tool and thread the cylinder case cap in place. Hold case cap in vise by flats and tighten cylinder to cap with strap wrench.

13. Push the piston rod until the piston clears the cylinder case by one inch. Fill the entire cylinder case with oil.
14. Draw piston five inches (5") into cylinder case by twisting and pulling piston rod. Any oil lost while drawing piston into cylinder must be replaced.
15. Slowly push and pull piston rod allowing piston to move in oil until all air bubbles cease to appear. During this pumping procedure, keep the top of piston below the surface of the oil. Replace any oil lost while pumping.
16. Thread the ring nut and membrane housing onto the cylinder. Tighten the housing hand tight. Do not tighten the ring nut at this time.
17. Place your finger over the hole in the bottom of the membrane housing and slowly lower the cylinder until oil flows out of the hole.
18. Keeping your finger over the hole in the membrane housing, remove the suspension unit from the vise and remount it so the top of the housing is at a slight angle.
NOTE: Do not move the piston rod in the cylinder during remounting because it may draw air into the cylinder.
19. Add oil to the membrane housing until it is half full. Remove finger and slowly pump the piston rod in and out until all bubbles cease to flow from the hole in the housing. When bubbles cease to appear, pump the piston rod an additional five (5) or six (6) times to insure that all trapped air is bled from the unit. Add oil as required to keep the housing at least $\frac{1}{2}$ full.

--- CAUTION ---

At no time should the oil level be allowed to fall below the hole in the bottom of the housing during the pumping procedure.

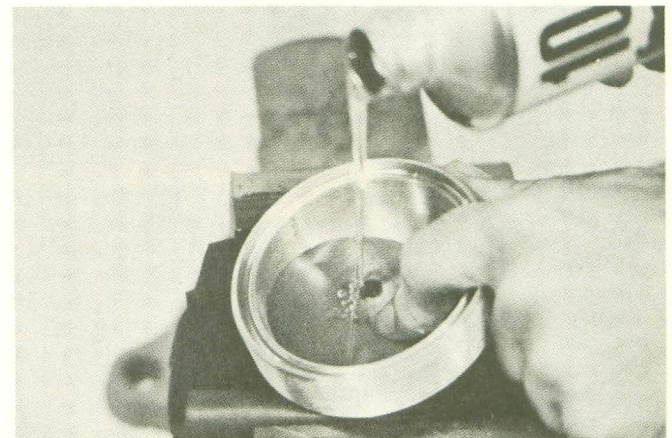
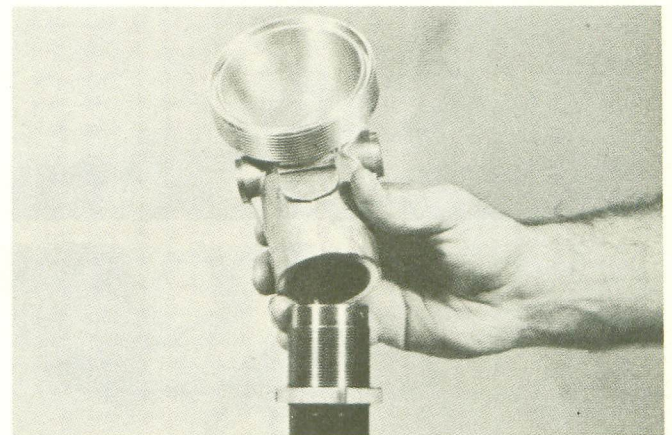
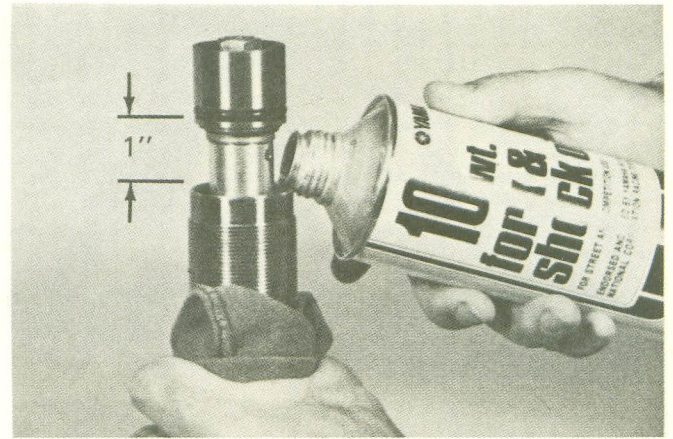

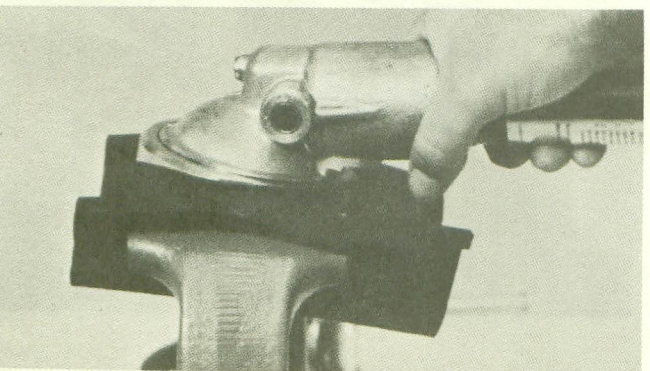
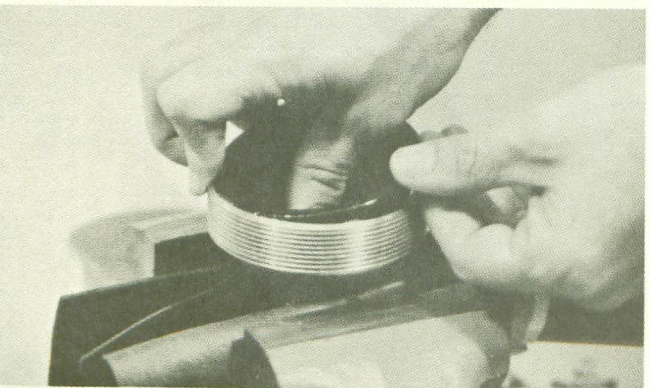
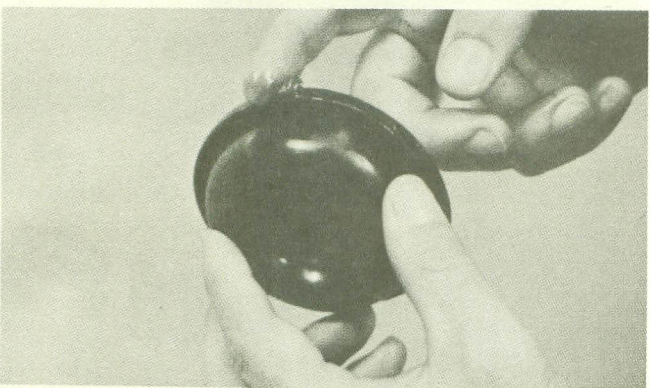
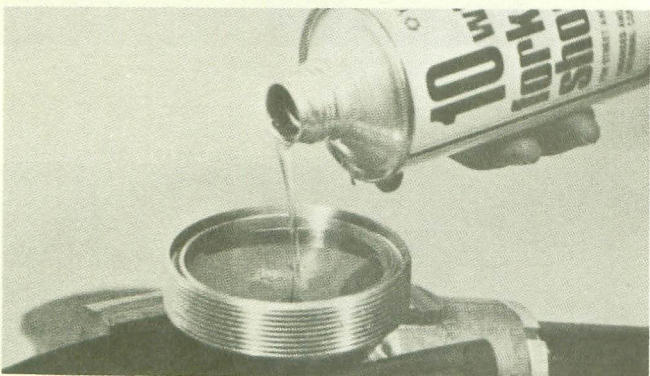
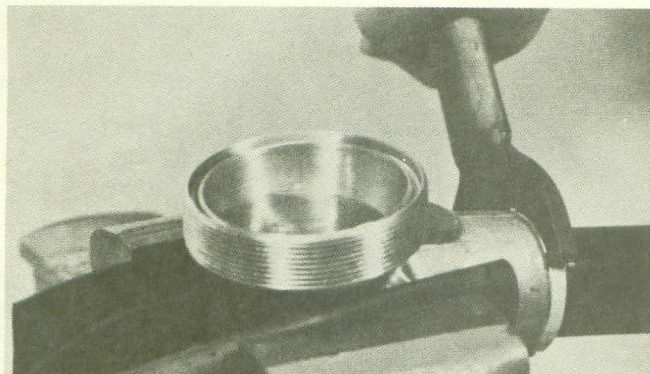

20. Tighten the cylinder in the membrane housing thoroughly by hand and tighten ring nut with ring nut wrench.

RING NUT TORQUE:
20m-Kgs (144.66 ft-lbs.)

21. Pull the piston rod out as far as it will go.

22. Fill the membrane housing completely full of oil.

23. Lightly grease the sealing edges of the membrane.

24. Push the center of the membrane down with your fingers and feed the sealing edge of the membrane into the groove of the membrane housing.

NOTE: The membrane will displace some oil from the housing while being installed. This is necessary to prevent any air from being trapped in the housing.

25. Wipe all excess oil from the top of the membrane. Grease the threads of the housing cap to prevent galling and thread the cap on as tight as possible by hand.

26. Hold the housing cap in vise and tighten the cap 1/16 to 1/8 turn using the membrane housing for leverage.

27. Clamp the suspension unit firmly in the vise by the rear mounting boss. The unit is now ready to be charged with nitrogen gas.

--- WARNING ---

Use only nitrogen to pressurize the gas chamber on the Monocross Suspension System. The use of any other gas can cause an explosion within the damper unit resulting in serious injury to anyone in the area.

28. Push the piston two inches (2") into the cylinder.
29. Thread the injector needle onto the nitrogen pressure hose and oil the injector needle lightly.
30. Close the regulator off completely by turning the knob in a counter-clockwise direction. Open the nitrogen bottle main valve.
31. Insert the injector into the rubber valve in the housing cap.

NOTE: Support the injector needle with your hand during pressurization.

32. Adjust the pressure regulator until the pressure reads 315 lbs. per square inch. Hold this pressure for one minute. The piston rod will be forced out as the gas fills the chamber.

MAXIMUM STATIC PRESSURE:
425 p.s.i.

--- CAUTION ---

Do not over-pressurize the gas chamber. Gradually increase the regulator setting until the required pressure is reached.

NOTE: See Page 17 for suggested pressure changes.

33. Close the nitrogen bottle main valve and remove the injector needle from the housing cap. This will allow the nitrogen pressure in the hose to flow out. Back off the pressure regulator.
34. Submerge the membrane housing in a bucket of water for a minimum of one minute and check for any bubbles that indicate a gas leak.
35. Dry the suspension unit thoroughly. Replace the blind screw using a new O-ring seal. Apply a light all purpose grease around the housing seal. Install the lower spring seat (1), spring (2), upper spring seat (3), rubber damper (4), and T-nut (5) (see Page 7). Tighten the T-nut as snug as possible by hand. The unit is now ready for re-installation on the bike.

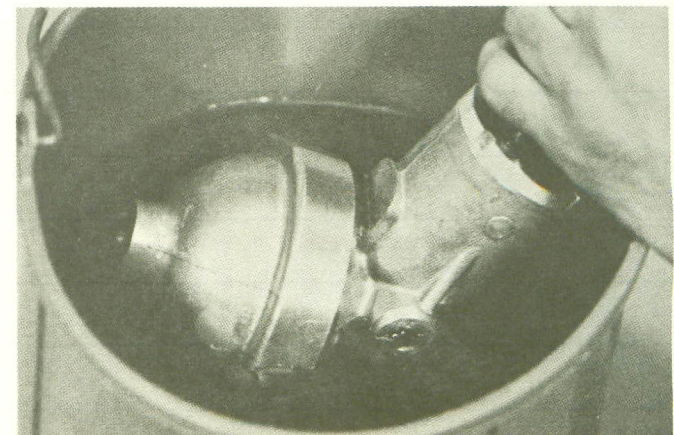
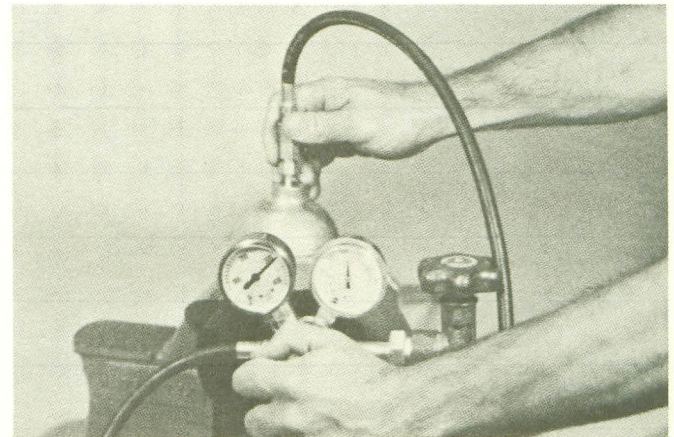
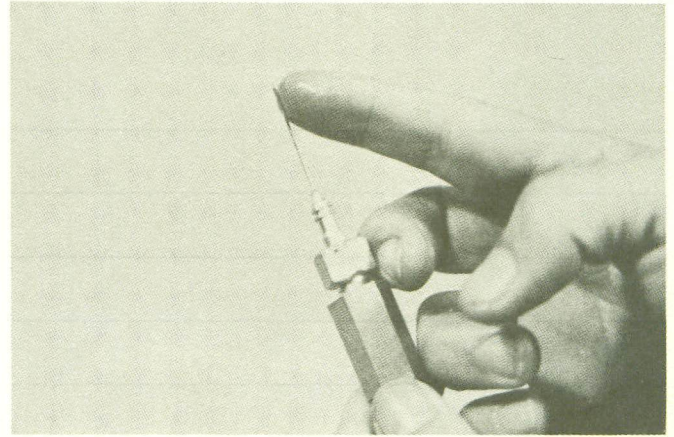

TUNING

TUNING CHANGE EXAMPLES	SPRING RATE		DAMPING	
	Increased (stiffer)	Decreased (softer)	Increased (slower return)	Decreased (faster return)
1. Reduce Gas Pressure 320 → 250 p.s.i.		✓	✓	
2. Increase Gas Pressure 320 → 370 p.s.i.	✓			✓
3. Change Spring 4.0 → 3.8 kg/mm (Use P/N 90501-80240-00)		✓	✓	
4. Change Spring 4.0 → 4.2 kg/mm (Use P/N 90501-80239-00)	✓			✓
5. Change Hydraulic Fluid* 10wt. → 20wt.			✓	
6. Change Hydraulic Fluid* 10wt. → 5wt.				✓

*Use only special fork or shock oils such as Yamaha Fork and Shock Fluid which is available from Y.P.D.I.

Before making tuning changes, have the rider take a few practice laps to evaluate the damping and spring rates. If you check rear suspension by simply pushing down on the rear of the frame, it will seem very stiff. This is a normal characteristic of the high pressure nitrogen system.

When making changes, do so one-at-a-time and test ride after each change. You are not restricted to the examples listed above. You can test other hydraulic fluid weights and other nitrogen pressures.

CAUTION: Use only nitrogen gas – maximum nitrogen pressure: 425 p.s.i.

SERVICE HINT: When assembling gas hose, adaptor and injector, use teflon, pipe-thread tape to seal all connections.

CONVERSION TABLE

Metric to Inch System

	KNOWN	MULTIPLIER (Rounded off)	RESULT
TORQUE	m-kg	7.233	ft-lbs
	m-kg	86.80	in-lbs
	cm-kg	0.0723	ft-lbs
	cm-kg	0.8680	in-lbs
WT.	kg	2.205	lb
	g	0.03527	oz
FLOW/DISTANCE	km/l	2.352	mpg
	km/hr	0.6214	mph
	km	0.6214	mi
	m	3.281	ft
	m	1.094	yd
	cm	0.3937	in
	mm	0.03937	in
VOL./CAPACITY	cc (cm ³)	0.03382	oz (U.S. liq.)
	cc (cm ³)	0.06102	cu. in.
	l (liter)	2.1134	pt (U.S. liq.)
	l (liter)	1.057	qt (U.S. liq.)
	l (liter)	0.2642	gal (U.S. liq.)
MISC.	kg/mm	56.007	lb/in
	kg/cm ²	14.2234	psi (lb/in ²)
	Centigrade (°C)	9/5 (°C) + 32	Fahrenheit (°F)

Inch to Metric System

	KNOWN	MULTIPLIER (Rounded off)	RESULT
TORQUE	ft-lbs	0.13826	m-kg
	in-lbs	0.01152	m-kg
	ft-lbs	13.831	cm-kg
	in-lbs	1.1521	cm-kg
WT.	lb	0.4535	kg
	oz	28.352	g
FLOW/DISTANCE	mpg	0.4252	km/l
	mph	1.609	km/hr
	mi	1.609	km
	ft	0.3048	m
	yd	0.9141	m
	in	2.54	cm
	in	25.4	mm
VOL./CAPACITY	oz (U.S. liq.)	29.57	cc (cm ³)
	cu. in.	16.387	cc (cm ³)
	pt (U.S. liq.)	0.4732	l (liter)
	qt (U.S. liq.)	0.9461	l (liter)
	gal (U.S. liq.)	3.785	l (liter)
MISC.	lb/in	0.017855	kg/mm
	psi (lb/in ²)	0.07031	kg/cm ²
	Fahrenheit (°F)	5/9 (°F - 32)	Centigrade (°C)

DEFINITION OF TERMS:

- m-kg = Meter-kilograms: Usually torque.
- g = Gram(s).
- kg = Kilogram(s): 1,000 grams.
- km = Kilometer(s).
- l = Liter(s).
- km/l = Kilometer(s) per liter: Mileage
- cc = Cubic centimeter(s) (cm³): Volume or capacity.
- kg/mm = Kilogram(s) per millimeter: Usually spring compression rate.
- kg/cm² = Kilogram(s) per square centimeter: Pressure.