



# YAMAHA

## PARTS CATALOGUE

### YZ80 (1LR)

S. AFRICA

| 61LR-664E1

[www.legends-yamaha-enduros.com](http://www.legends-yamaha-enduros.com)

**A2**

www.legends-yamaha-enduros.com

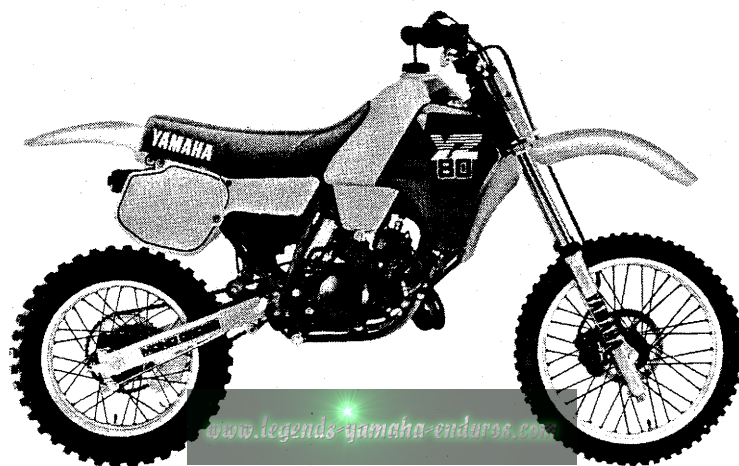

www.legends-yamaha-enduros.com

A3

# FOREWORD

This Parts Catalogue is related to the parts in use for the Yamaha YZ80 (1LR).  
When you are ordering replacement parts for the YZ80 (1LR), refer to this Parts Catalogue and quote both part numbers and part names correctly.

1. Modifications or additions which have been made after issue of the Parts Catalogue will be announced in the Yamaha Parts News.

It is advisable that according to the Yamaha Parts News you make necessary corrections to the Parts Catalogue on hand to keep it up-to-date.

2. Abbreviations

The following abbreviations are used in this Parts Catalogue.

U.R. Use size (thickness) and/or number as required.

U.N. Use as many as you need.

A.P. Alternate Parts

L.M. Local Made

F# Frame No. (Applicable machine No.)

3. The parts marked with (\*) in the parts number column of this Catalogue are not supplied with by Yamaha, those have to be found locally.

4. Parts, which are to be supplied in the form of assemblies, are listed with an indentation of one letter's space, and a dot ( . ) is put against the name of each part.

**EXAMPLE** CARBURETOR ASS'Y  
     . JET, pilot  
     . NOZZLE, main

5. Indication of No. of constituent parts for assembly

The numeral appearing to the right of each constituent part under the description indicates the quantity of such parts for each individual assembly unit.

**EXAMPLE**

Part No.	Description	Q'ty	Remarks
2F5-83310-60	FRONT FLASHER LIGHT ASS'Y	2	
115-83311-60	. BULB (6V-18W)	1	
1M1-83309-60	. REFLECTOR	1	

6. Initial Serial No. and Color Code

(A) Frame Serial No.	1LR-000101 and following
(B) Engine Serial No.	1LR-000101 and following

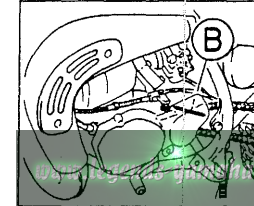
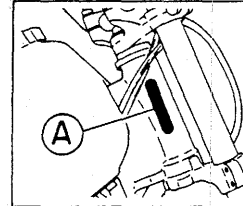

Color Code	Color Name	Abbreviate
36	Clean White	W

7. Applicable colors of graphics are represented in the "Remarks" column by the letter(s) appropriately picked out of the full word(s) showing such colors.

**EXAMPLE**

Part No.	Description	Q'ty	Remarks
2N4-24110-00-X5	FUEL TANK COMP.	1	MAXIM RED
3J1-24240-10	. GRAPHIC, fuel tank set	1	for MXR

# CONTENTS

## ENGINE

Cylinder .....	B2
Crankshaft · Piston .....	B3
Water Pump .....	B4
Radiator · Hose .....	B5
Intake .....	B6 ~ B7
Carburetor .....	B8 ~ B9
Exhaust .....	B10
Crankcase .....	B11
Crankcase Cover 1 .....	B12
Starter .....	B13
Clutch .....	B14
Transmission .....	B15
Shift Cam · Fork .....	C2
Shift Shaft .....	C3

## CHASSIS

Frame .....	C4
Fender .....	C5
Side Cover .....	C6
Rear Arm .....	C7 ~ C8
Rear Suspension .....	C9 ~ C10
Steering .....	C11
Front Fork .....	C12 ~ C13
Fuel Tank .....	C14 ~ C15
Seat .....	D2
Front Wheel .....	D3
Front Brake Caliper .....	D4
Rear Wheel .....	D5 ~ D6
Steering Handle · Cable .....	D7

Front Master Cylinder .....	D8
Stand · Footrest .....	D9 ~ D10
Generator .....	D11
Handle Switch · Lever .....	D12
Electrical 1 .....	D13

## ALTERNATE PARTS

Alternate 1 (Chassis) .....	D14
-----------------------------	-----

## REPAIR KIT

Repair Kit .....	D15
------------------	-----

## INDEX

Numerical Index .....	M1 ~ M3
-----------------------	---------

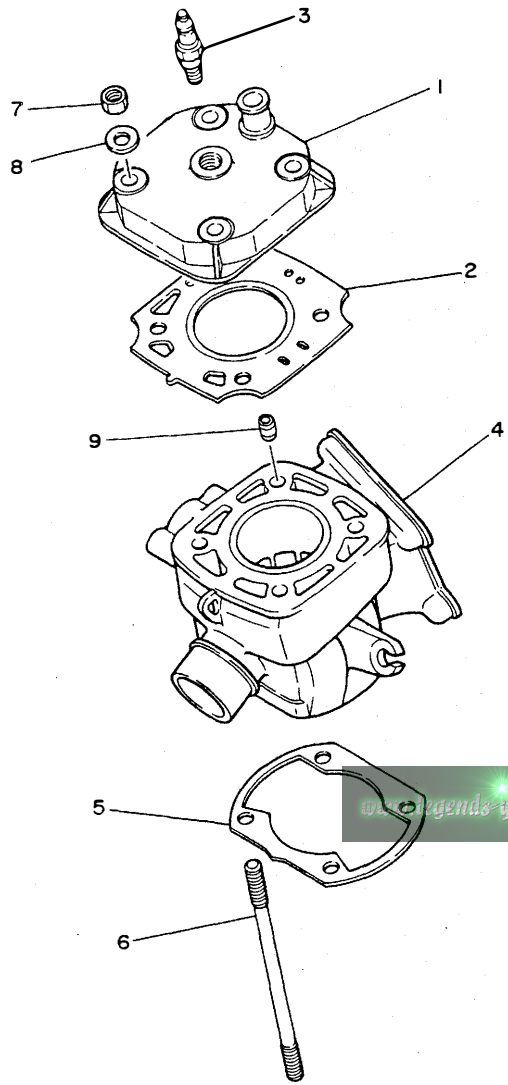

FIG. 1 CYLINDER

REF. NO.	PART NO.	DESCRIPTION	Q'TY	REMARKS
1	1LR-11111-00	HEAD, cylinder 1	1	
2	1LR-11181-00	GASKET, cylinder head 1	1	
3	*	PLUG, spark (CHAMPION QN-86)	1	LM
4	1LR-11311-00	CYLINDER 1	1	
5	4V0-11351-00	GASKET, cylinder	1	
6	90116-08402	BOLT, stud	4	
7	95311-08600	NUT	4	
8	90201-08649	WASHER, plate	4	
9	99510-10114	PIN, dowel	2	



ILR100-6010

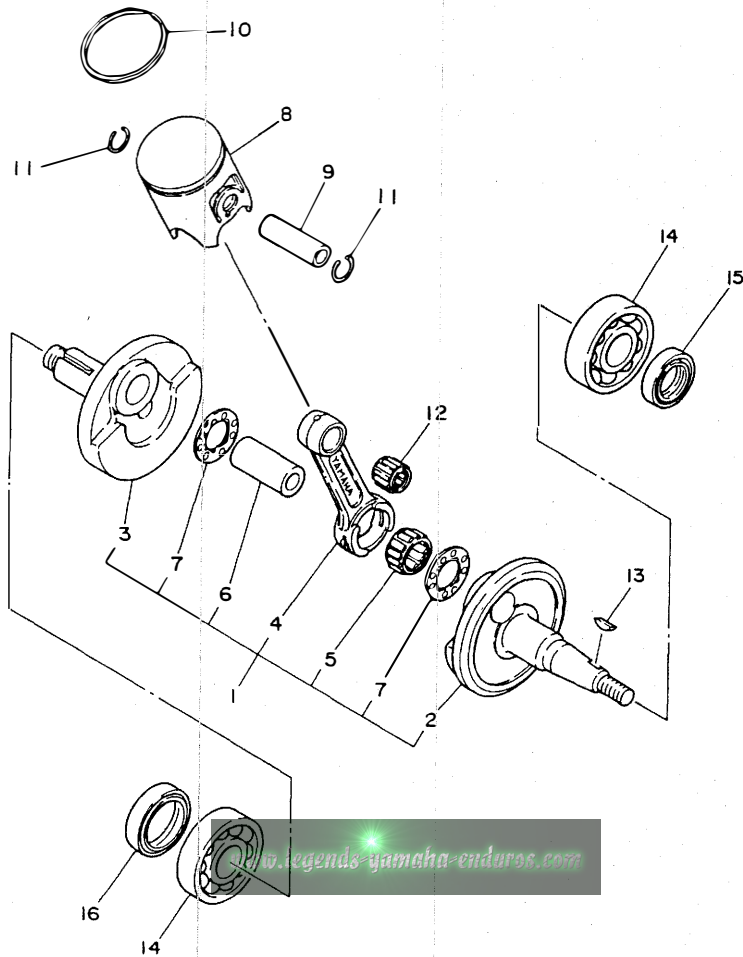

FIG. 2 CRANKSHAFT. PISTON

REF. NO.	PART NO.	DESCRIPTION	Q'TY	REMARKS
1	1LR-11400-00	CRANKSHAFT ASSY	1	
2	39K-11412-00	.CRANK 1	1	
3	39K-11422-00	.CRANK 2	1	
4	1LR-11651-00	.ROD, connecting	1	
5	93310-418M6	.BEARING, cylindrical	1	
6	4V0-11681-00	.PIN, crank 1	1	
7	90209-18112	.WASHER	2	
8	58T-11631-00-94	PISTON (STD)	1	UR
	58T-11631-00-95	PISTON (STD)	1	UR
	58T-11635-00	PISTON (0.25MM O/S)	1	AP
	58T-11636-00	PISTON (0.50MM O/S)	1	AP
9	4V1-11633-00	PIN, piston	1	
10	39K-11611-00	RING, piston	1	STD
	39K-11611-10	RING, piston	1	AP
	39K-11611-20	RING, piston	1	AP
11	5X2-11634-00	CLIP, piston pin	2	
12	93310-312M5	BEARING, cylindrical	1	
13	90280-03017	KEY, woodruff	1	
14	93306-20438	BEARING	2	
15	93102-20231	OIL SEAL	1	
16	93103-28126	OIL SEAL	1	



ILR100-6020

**B3**

FIG. 3 WATER PUMP

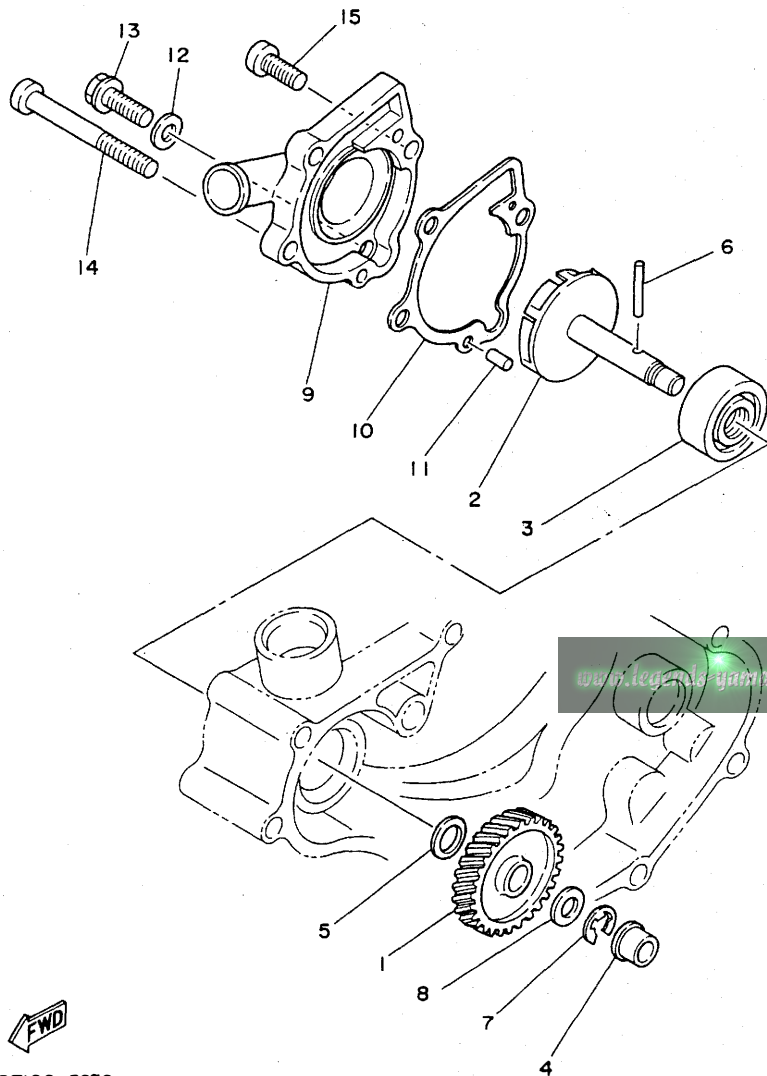

REF. NO.	PART NO.	DESCRIPTION	QTY	REMARKS
1	1LR-12459-00	GEAR, impeller shaft	1	
2	22W-12450-00	IMPELLER SHAFT ASSY	1	
3	93103-10147	OIL SEAL	1	
4	90381-08002	BUSH, solid	1	
5	90201-10614	WASHER, plate	1	
6	93603-22028	PIN, dowel	1	
7	99001-07600	CIRCLIP	1	
8	90201-08085	WASHER, plate	1	
9	39K-12422-00	COVER, housing	1	
10	5X2-12428-00	GASKET, housing cover 2	1	
11	93604-10011	PIN, dowel	2	
12	90430-06166	GASKET	1	
13	95826-06020	BOLT, flange	1	
14	92506-06060	SCREW, pan head	2	
15	92506-06020	SCREW, pan head	1	



58T100-5030

**B4**

FIG. 4 RADIATOR. HOSE

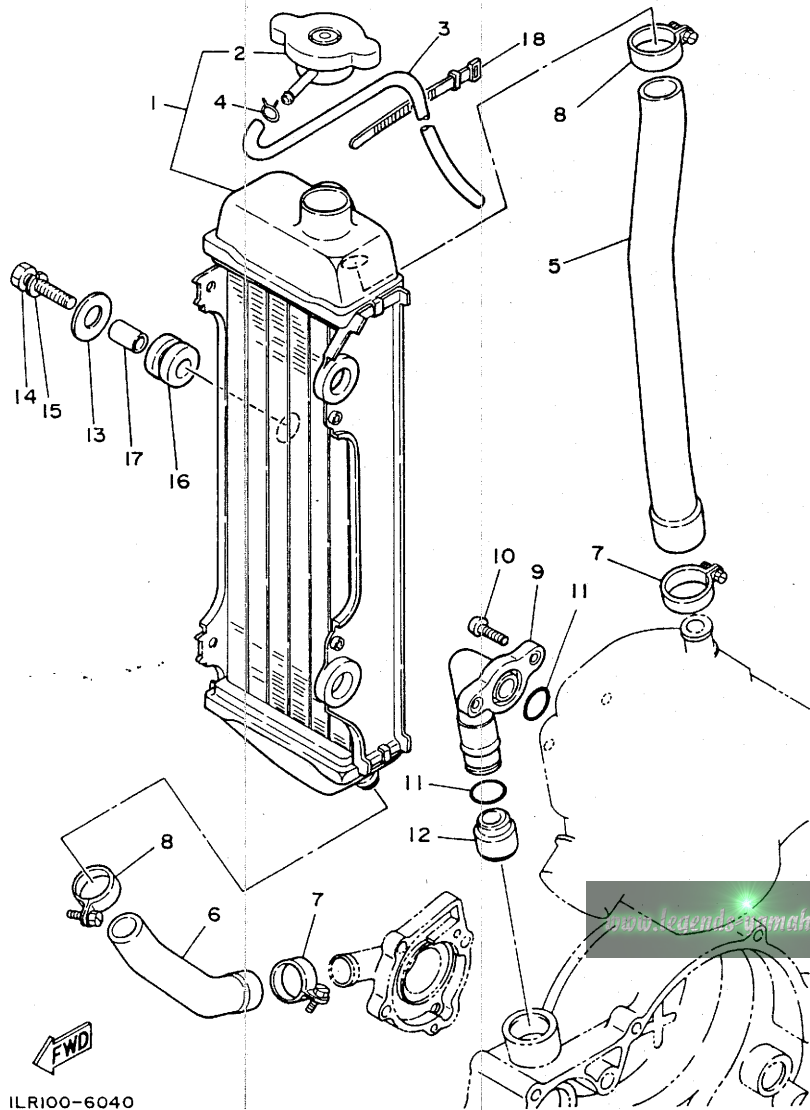

REF. NO.	PART NO.	DESCRIPTION	Q'TY	REMARKS
1	1LR-12460-00	RADIATOR ASSY	1	
2	22W-12462-00	.CAP, radiator	1	
3	22W-12463-00	PIPE, breather	1	
4	90467-08004	CLIP	1	
5	39K-12481-00	PIPE 1	1	
6	39K-12482-00	PIPE 2	1	
7	90460-27281	CLAMP, hose	2	
8	90460-22252	CLAMP, hose	2	
9	39K-12446-00	JOINT	1	
10	92506-06016	SCREW, pan head	2	
11	93210-16275	O-RING	2	
12	4V2-12494-00	SEAL, pipe 1	1	
13	90201-061H3	WASHER, plate	3	
14	97301-06030	BOLT	3	
15	92990-06100	WASHER, spring	3	
16	90480-15064	GROMMET	3	
17	90387-07392	COLLAR	3	
18	437-83936-00	BAND, switch cord	1	

FWD  
ILR100-6040

**B5**



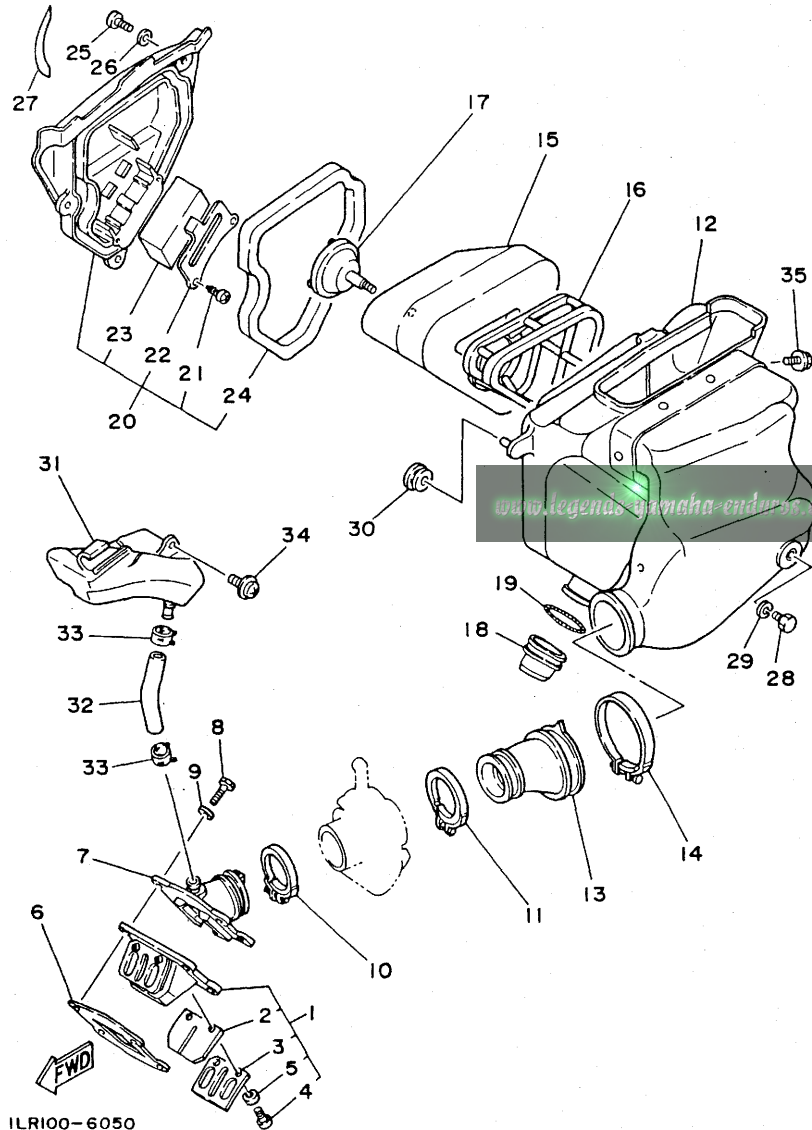
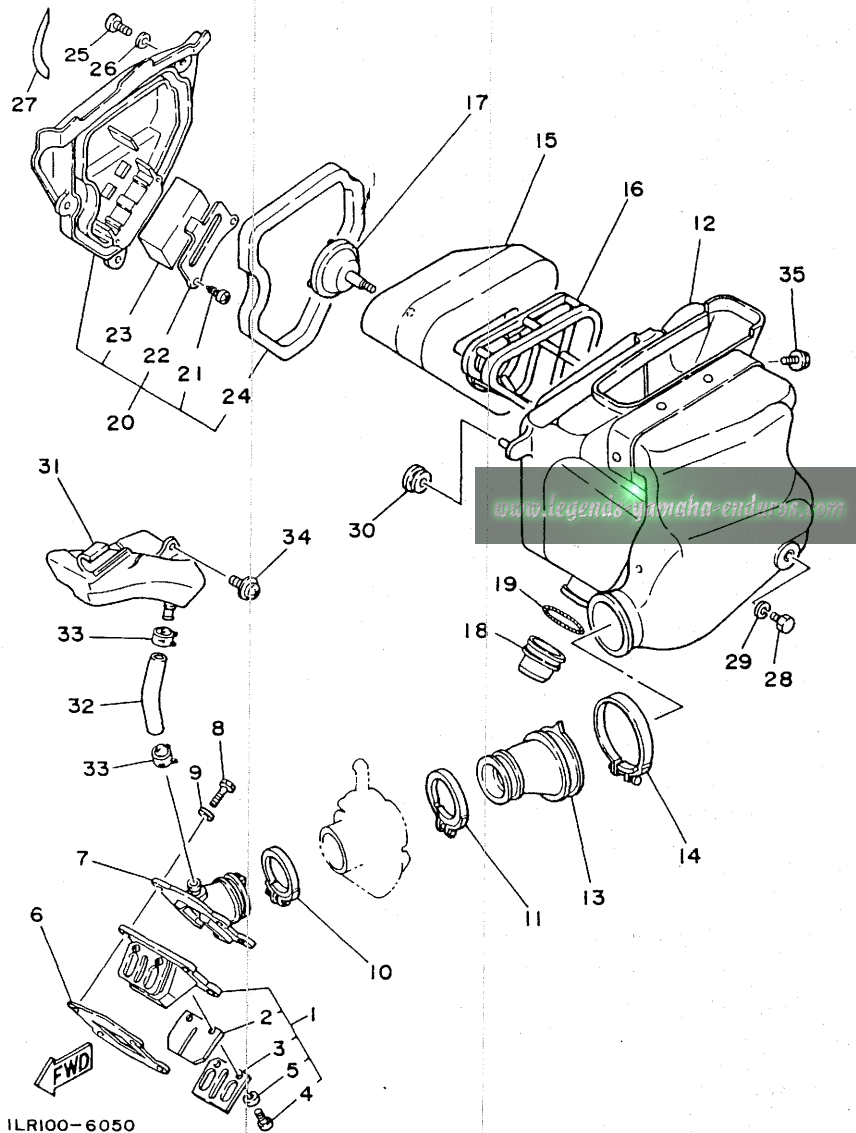

FIG. 5 INTAKE

REF. NO.	PART NO.	DESCRIPTION	Q'TY	REMARKS
1	58T-13610-01	REED VALVE ASSY	1	
2	58T-13613-00	.REED, valve	2	
3	58T-13616-00	.STOPPER, reed valve	2	
4	98501-03008	.SCREW, pan head	4	
5	92990-03100	.WASHER, spring	4	
6	1LR-13621-00	GASKET, valve seat	1	
7	1LR-13565-00	JOINT, carburetor	1	
8	97301-06025	BOLT	4	
9	92901-06600	WASHER, plate	4	
10	90460-43053	CLAMP, hose	1	
11	90460-51059	CLAMP, hose	1	
12	39K-14401-02	AIR CLEANER CASE ASSY	1	
13	39K-14453-00	JOINT, air cleaner 1	1	
14	90460-58015	CLAMP, hose	1	
15	39K-14451-00	ELEMENT, air cleaner	1	
16	39K-14458-00	GUIDE	1	
17	4V2-14468-02	PLATE, element fitting	1	
18	39K-14457-00	SEAL	1	
19	90504-03033	SPRING, compression	1	
20	1LR-14402-00	CAP ASSY, air cleaner	1	
21	97702-40116	.SCREW, tapping	2	
22	5X5-1441L-00	.PANEL 1	1	
23	39K-14467-00	.SEAL	1	
24	39K-14452-00	.SEAL	1	
25	92501-06014	SCREW, pan head	3	
26	92901-06600	WASHER, plate	3	
27	1LR-2174G-00	GRAPHIC 3	1	
28	97301-06012	BOLT	1	



ILR100-6050

FIG. 5 INTAKE

REF. NO.	PART NO.	DESCRIPTION	Q'TY	REMARKS
29	92990-06100	WASHER, spring	1	
30	90480-13197	GROMMET	1	
31	22W-13581-00	CHAMBER, air	1	
32	90445-164E1	HOSE	1	
33	90467-16063	CLIP	2	
34	90159-06033	SCREW, with washer	1	
35	90119-06085	BOLT, with washer	1	

FIG. 6 CARBURETOR

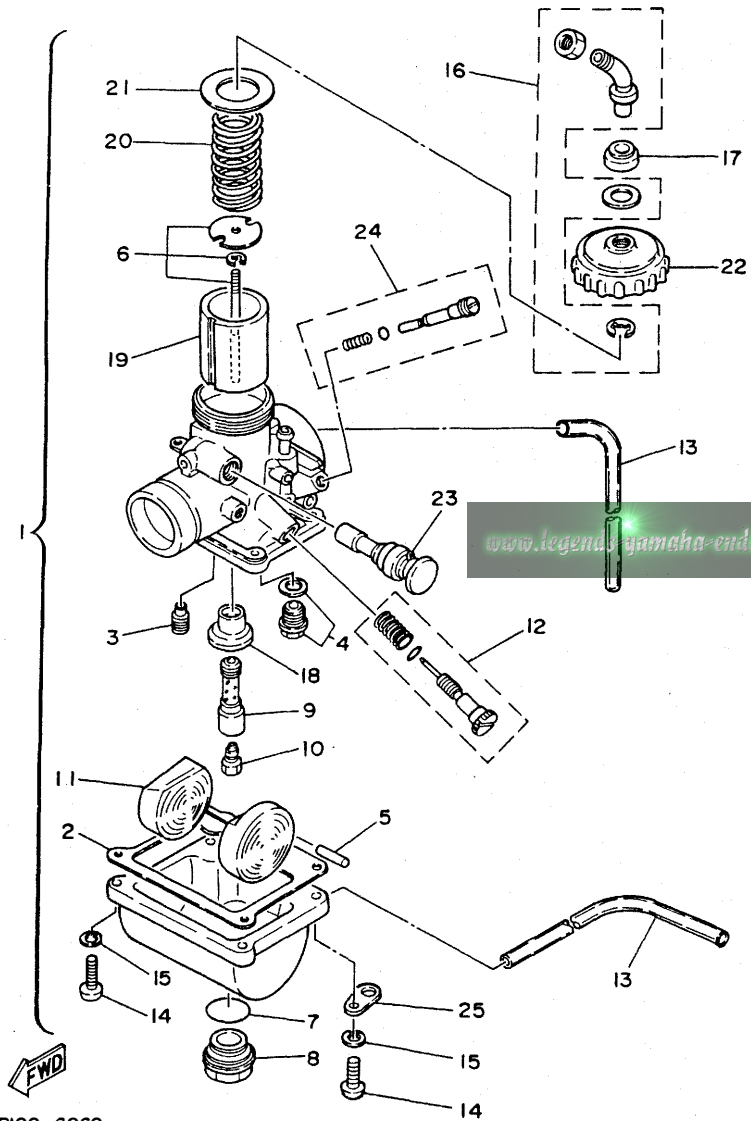

REF. NO.	PART NO.	DESCRIPTION	QTY	REMARKS
1	1LR-14101-00	CARBURETOR ASSY 1	1	
2	304-14184-00	.GASKET, float chamber	1	
3	260-14142-35	.JET, pilot (# 35)	1	STD
	260-14142-30	.JET, pilot (# 30)	1	AP
	260-14142-40	.JET, pilot (# 40)	1	AP
4	23L-14107-25	.NEEDLE VALVE SET	1	
5	127-14186-00	.PIN, float	1	
6	58T-1490J-00	.NEEDLE SET	1	
7	93210-18288	.O-RING	1	
8	3R1-14115-00	.PLUG, screw	1	
9	3R1-14141-52	.NOZZLE, main	1	STD
	3R1-14141-50	.NOZZLE, main	1	AP
	3R1-14141-54	.NOZZLE, main	1	AP
10	137-14143-54	.JET, main (#270)	1	STD
	137-14143-52	.JET, main (#260)	1	AP
	137-14143-56-A0	.JET, main (#280)	1	AP
	137-14143-58	.JET, main (#290)	1	AP
11	314-14185-00	.FLOAT	1	
12	31J-14103-00	.THROTTLE SCREW SET	1	
13	183-14196-00	.PIPE	3	
14	98511-04016	.SCREW, pan head	4	
15	92902-04100	.WASHER, spring	4	
16	22W-14106-00	.CABLE ADJUST SCREW SET	1	
17	3X3-14169-00	.CAP	1	
18	39K-14153-00	.WASHER, main jet	1	
19	2X6-14112-30	.VALVE, throttle 1	1	STD
	2X6-14112-25	.VALVE, throttle 1	1	AP
	2X6-14112-35	.VALVE, throttle 1	1	AP

ILR100-6060

FIG. 6 CARBURETOR

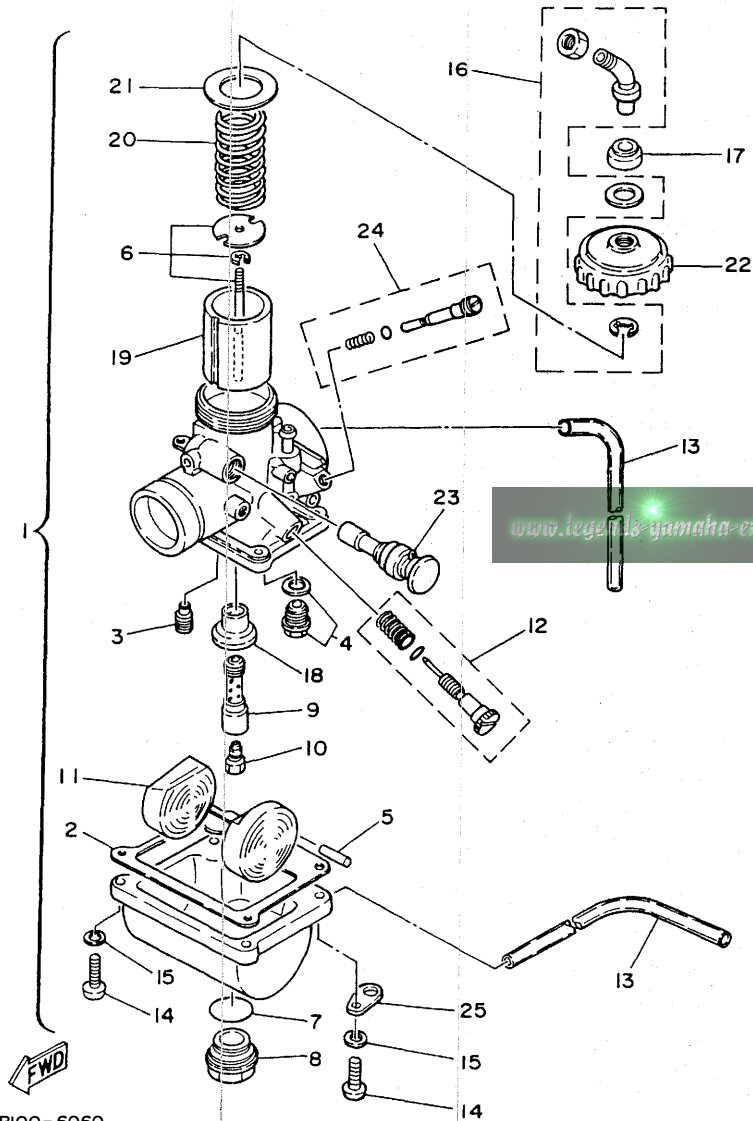

REF. NO.	PART NO.	DESCRIPTION	Q'TY	REMARKS
20	248-14131-00	.SPRING, throttle valve	1	
21	2A6-14126-00	.GASKET	1	
22	2A6-14158-00	.TOP, mixing chamber	1	
23	4U5-14171-00	.PLUNGER, starter	1	
24	10W-14104-00	.AIR SCREW SET	1	
25	132-14146-00	.PLATE	1	

ILR100-6060

B9

FIG. 7 EXHAUST

REF. NO.	PART NO.	DESCRIPTION	QTY	REMARKS
1	58T-14610-00	EXHAUST PIPE ASSY 1	1	
2	39K-14718-00	PROTECTOR, muffler 1	1	
3	98906-06008	SCREW, bind	2	
4	90202-06010	WASHER, plate	2	
5	1LR-14613-00	GASKET, exhaust pipe	1	
6	90507-20030	SPRING, tension	2	
7	565-14771-00	STAY, muffler 1	1	
8	97301-06016	BOLT	2	
9	92990-06100	WASHER, spring	2	
10	92901-06600	WASHER, plate	2	
11	1LR-14753-00	SILENCER, exhaust	1	

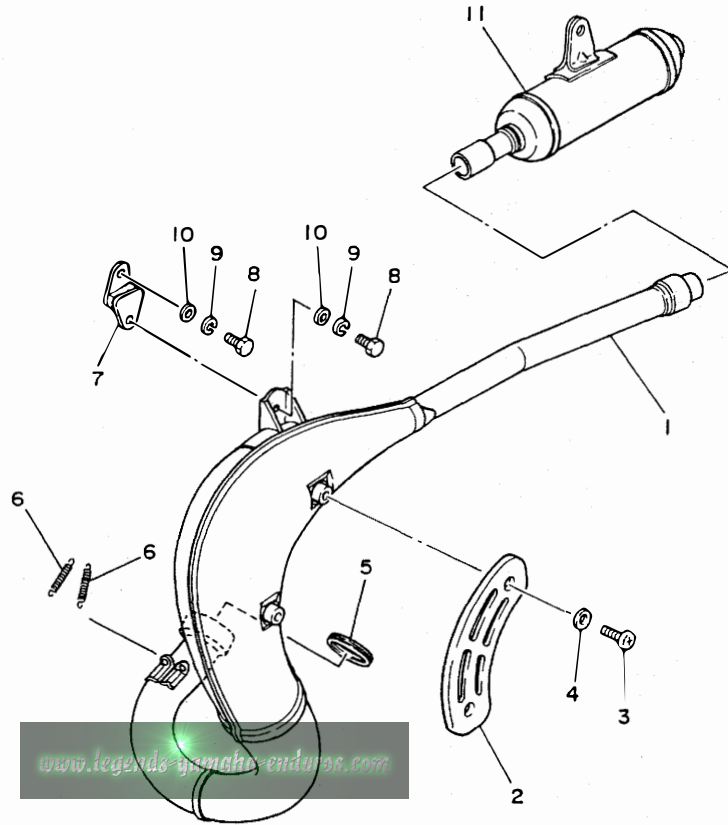

www.legends-yamaha-enduros.com



ILR100-6070

**B10**

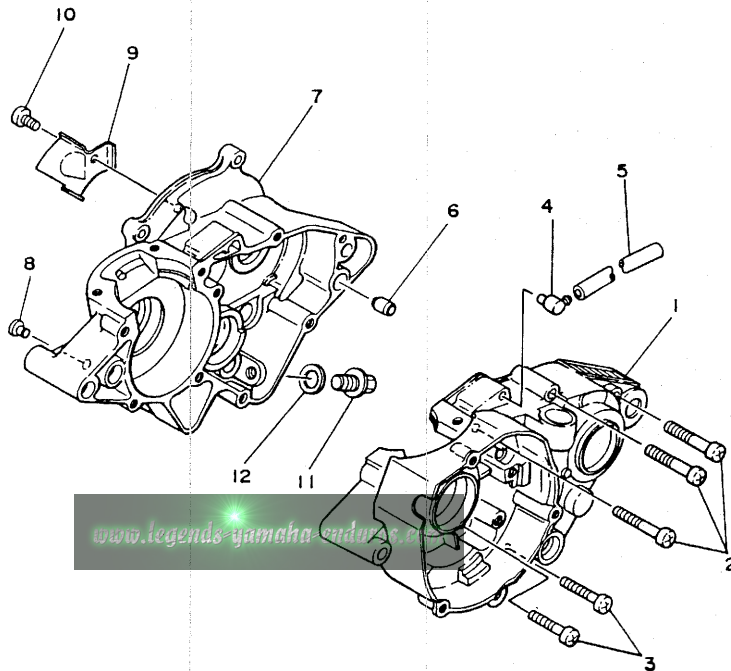

FIG. 8 CRANKCASE

REF. NO.	PART NO.	DESCRIPTION	Q'TY	REMARKS
1	39K-15111-00	CRANKCASE 1	1	
2	92501-06045	SCREW, pan head	6	
3	92501-06035	SCREW, pan head	3	
4	353-13115-01	CONNECTOR, suction pipe	1	
5	90445-08376	HOSE	1	
6	99530-12016	PIN, dowel	2	
7	39K-15121-00	CRANKCASE 2	1	
8	90338-07011	PLUG	1	
9	5X2-15113-01	PLATE	1	
10	92501-06012	SCREW, pan head	1	
11	90340-12095	PLUG, straight screw	1	
12	90430-12038	GASKET	1	

www.legends-yamaha-indonesia.com



22W100-3090

**B11**

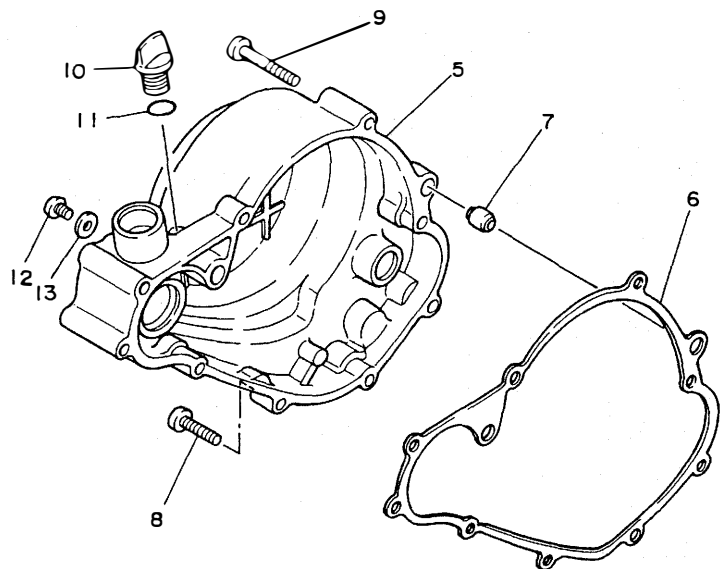
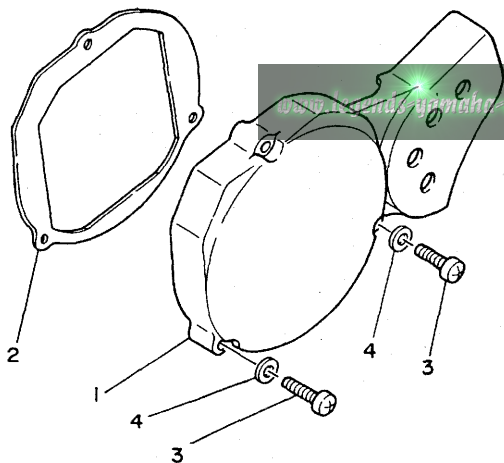

FIG. 9 CRANKCASE COVER 1

REF. NO.	PART NO.	DESCRIPTION	Q'TY	REMARKS
1	58T-15411-00	COVER, crankcase 1	1	
2	22W-15451-00	GASKET, crankcase cover 1	1	
3	92506-06030	SCREW, pan head	3	
4	92906-06600	WASHER, plate	3	
5	1LR-15421-00	COVER, crankcase 2	1	
6	5X2-15462-00	GASKET, crankcase cover 3	1	
7	99530-10014	PIN, dowel	2	
8	92506-06025	SCREW, pan head	6	
9	92506-06040	SCREW, pan head	1	
10	4J2-15363-00	PLUG, oil	1	
11	93210-14104	O-RING	1	
12	92506-06008	SCREW, pan head	1	
13	90430-06016	GASKET	1	



58T100-5090

**B12**

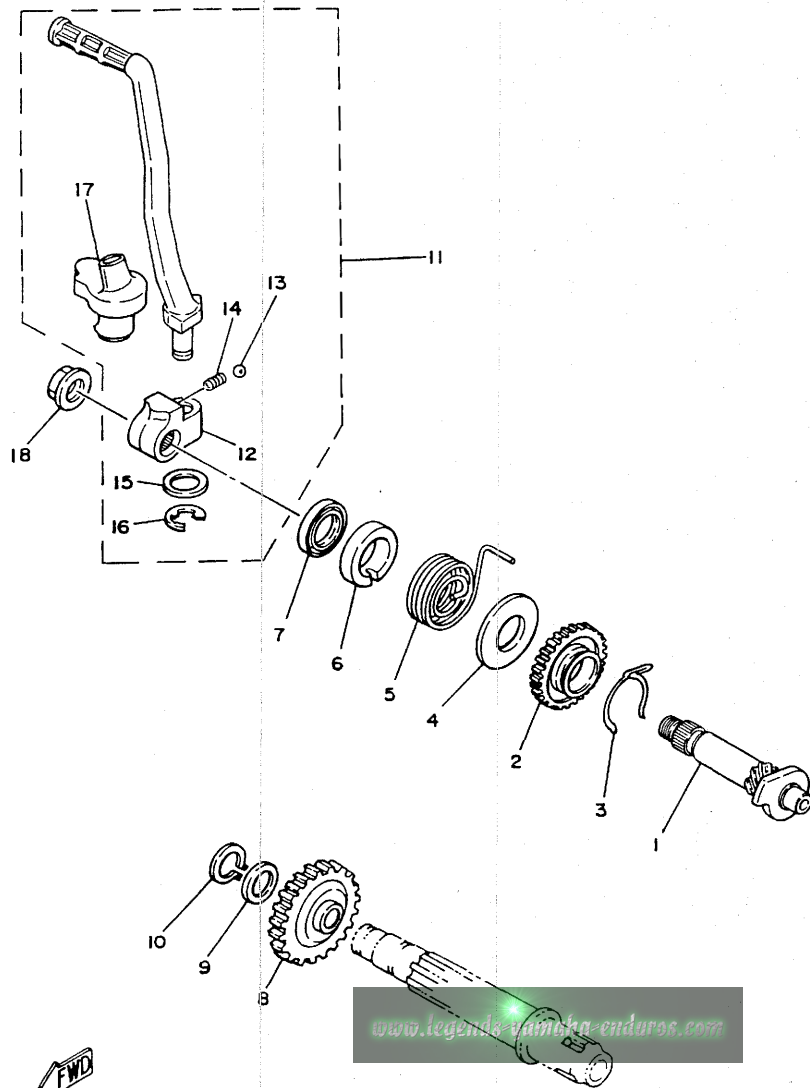

FIG. 10 STARTER

REF. NO.	PART NO.	DESCRIPTION	Q'TY	REMARKS
1	22W-15660-00	KICK AXLE ASSY	1	
2	4V0-15641-00	GEAR, kick (24T)	1	
3	90468-26046	CLIP	1	
4	90201-154A1	WASHER, plate	1	
5	90508-26464	SPRING, torsion	1	
6	4V0-15664-00	GUIDE, spring	1	
7	93109-15001	OIL SEAL	1	
8	4V0-15651-00	GEAR, sprocket idle (25T)	1	
9	90201-12163	WASHER, plate	1	
10	99009-12400	CIRCLIP	1	
11	22W-15620-00	KICK CRANK ASSY	1	
12	4V0-15621-00	.BOSS, kick crank	1	
13	93507-32009	.BALL	1	
14	90501-12081	.SPRING, compression	1	
15	90201-12631	.WASHER, plate	1	
16	93430-08007	.CIRCLIP	1	
17	4V0-15618-00	.COVER, kick lever	1	
18	95702-10500	NUT, flange	1	

FWD  
22W100-3110

www.legends-yamaha-enduros.com

**B13**



FIG. 11 CLUTCH

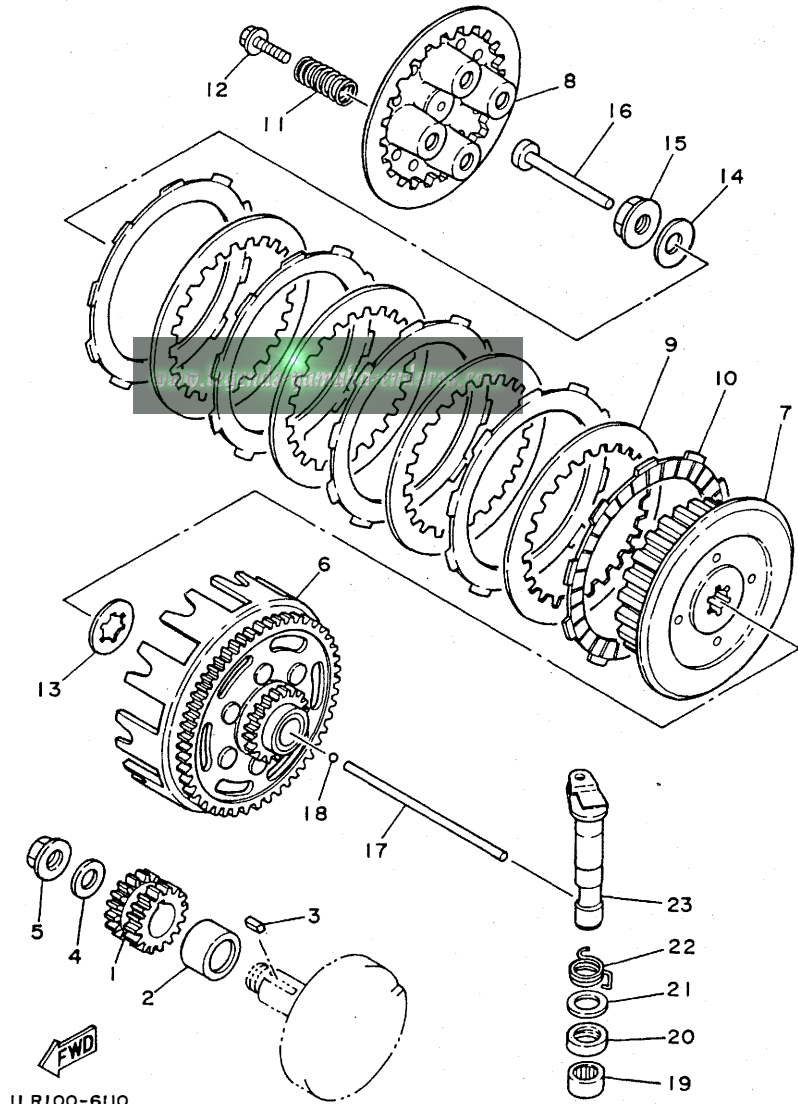

ILR100-6110

REF. NO.	PART NO.	DESCRIPTION	Q'TY	REMARKS
1	1LR-16111-00	GEAR, primary drive	1	
2	90387-202F0	COLLAR	1	
3	90282-05001	KEY, straight	1	
4	90208-12015	WASHER, conical spring	1	
5	90179-12335	NUT	1	
6	1LR-16150-00	PRIMARY DRIVEN GEAR COMP.	1	
7	1LR-16371-00	BOSS, clutch	1	
8	1LR-16351-00	PLATE, pressure 1	1	
9	257-16324-00	PLATE, clutch 1	5	
10	21V-16321-00	PLATE, friction	6	
11	90501-204A0	SPRING, compression	4	
12	90159-05011	SCREW, with washer	4	
13	4V0-16154-00	PLATE, thrust 1	1	
14	90208-12015	WASHER, conical spring	1	
15	90179-12244	NUT	1	
16	137-16356-00	ROD, push 1	1	
17	2X3-16357-00	ROD, push 2	1	
18	93503-16010	BALL	1	
19	93315-21429	BEARING, cylindrical	1	
20	93109-14021	OIL SEAL	1	
21	90201-14411	WASHER, plate	1	
22	90508-18463	SPRING, torsion	1	
23	58T-16382-00	AXLE, push lever	1	

**B14**

FIG. 12 TRANSMISSION

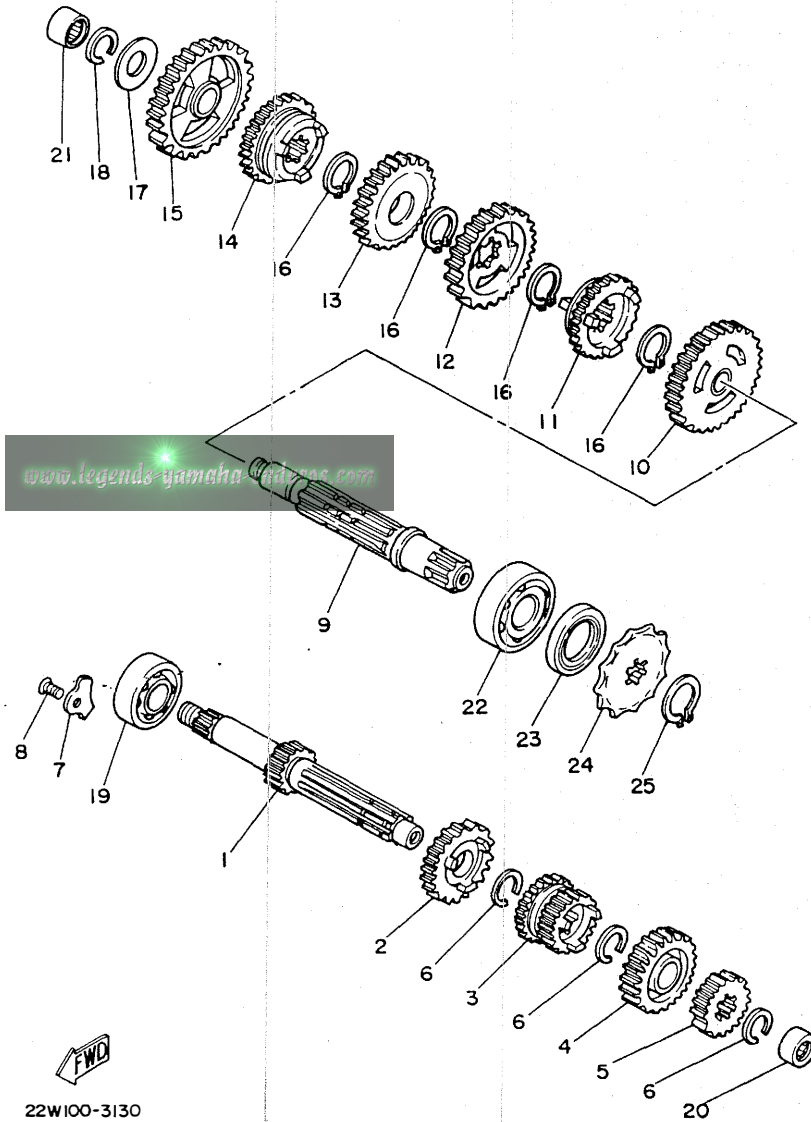

REF. NO.	PART NO.	DESCRIPTION	Q'TY	REMARKS
1	4V0-17411-02	AXLE, main	1	
2	39K-17151-01	GEAR, 5th pinion (22T)	1	
3	39K-17131-00	GEAR, 3rd pinion (16T/19T)	1	
4	39K-17161-01	GEAR, 6th pinion (23T)	1	
5	4V0-17121-00	GEAR, 2nd pinion (16T)	1	
6	93440-16089	CIRCLIP	3	
7	3R4-15383-01	PLATE, bearing cover	2	
8	92701-06012	SCREW, flat head	2	
9	22W-17421-00	AXLE, drive	1	
10	39K-17221-00	GEAR, 2nd wheel (33T)	1	
11	39K-17261-01	GEAR, 6th wheel (26T)	1	
12	4V0-17231-00	GEAR, 3rd wheel (31T)	1	
13	39K-17241-00	GEAR, 4th wheel (22T)	1	
14	39K-17251-01	GEAR, 5th wheel (27T)	1	
15	4V0-17211-00	GEAR, 1st wheel (36T)	1	
16	93410-20038	CIRCLIP	4	
17	164-17427-00-06	SHIM 1 (0.6T)	1	
18	93440-15012	CIRCLIP	1	
19	93306-20333	BEARING	1	
20	93317-11245	BEARING, cylindrical	1	
21	93315-31502	BEARING, cylindrical	1	
22	93306-20401	BEARING (B6204)	1	
23	93102-20143	OIL SEAL	1	
24	174-17461-40	SPROCKET, drive (14T)	1 STD	
	174-17461-20	SPROCKET, drive (12T)	1 AP	
	174-17461-30	SPROCKET, drive (13T)	1 AP	
	174-17461-50	SPROCKET, drive (15T)	1 AP	
25	99009-18400	CIRCLIP	1	

  
22W100-3130

**B15**

www.legends-yamaha-enduros.com

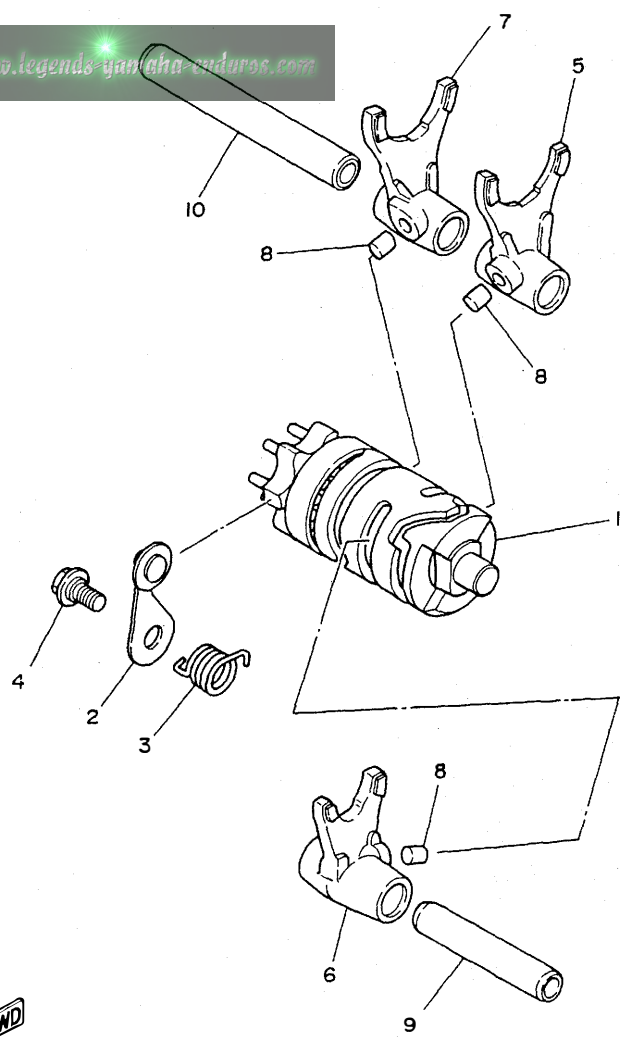

FIG. 13 SHIFT CAM. FORK

REF. NO.	PART NO.	DESCRIPTION	Q'TY	REMARKS
1	22W-18540-00	SHIFT CAM ASSY	1	
2	22W-18140-00	STOPPER LEVER ASSY	1	
3	90508-26462	SPRING, torsion	1	
4	1W1-18177-00	BOLT, stopper	1	
5	4V0-18511-00	FORK, shift 1	1	
6	39K-18512-00	FORK, shift 2	1	
7	4V0-18513-00	FORK, shift 3	1	
8	90250-06013	PIN, straight	3	
9	5X5-18531-01	BAR, shift fork guide 1	1	
10	5X5-18535-01	BAR, shift fork guide 2	1	



22W100-3140

C2

FIG. 14 SHIFT SHAFT

REF. NO.	PART NO.	DESCRIPTION	Q'TY	REMARKS
1	22W-18101-00	SHIFT SHAFT ASSY	1	
2	99001-10600	CIRCLIP	1	
3	90508-32642	SPRING, torsion	1	
4	93608-30128	PIN, dowel	1	
5	93109-12012	OIL SEAL	1	
6	22W-18110-00	SHIFT PEDAL ASSY	1	
7	97321-06020	BOLT	1	

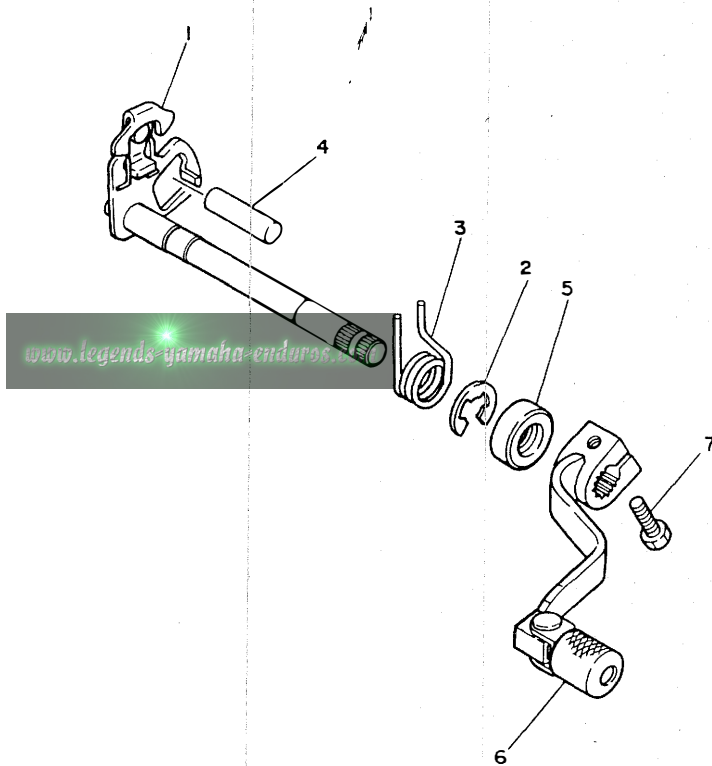

22W100-3150

C3

FIG. 15 FRAME

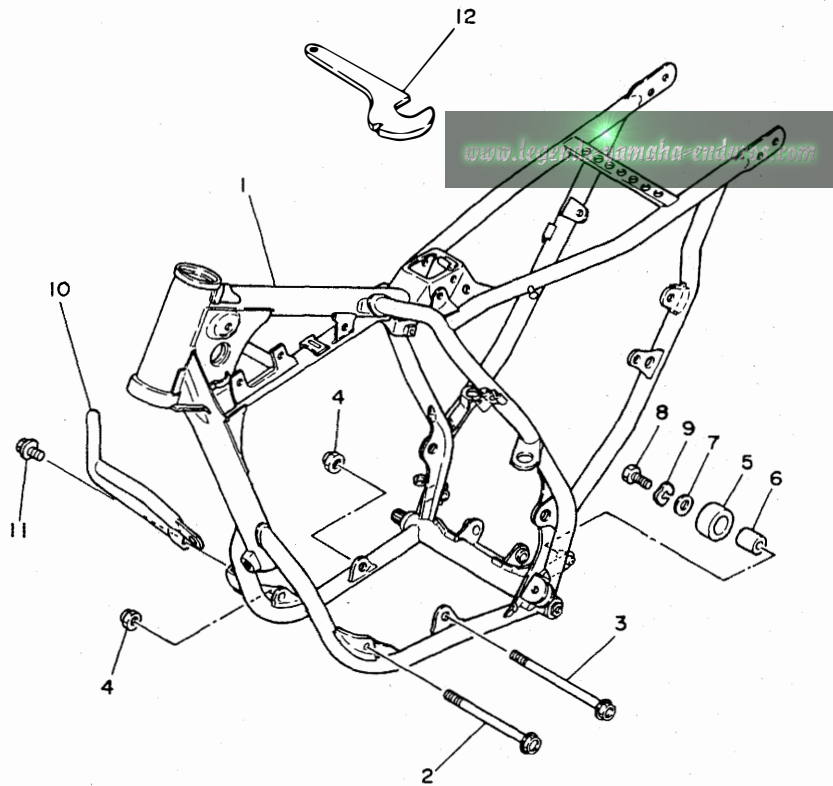

REF. NO.	PART NO.	DESCRIPTION	Q'TY	REMARKS
1	1LR-21110-00-FH	FRAME COMP.	1	fire red
2	95811-08125	BOLT, flange	1	
3	95811-08135	BOLT, flange	1	
4	90185-08113	NUT, self-locking	2	
5	30X-22178-00	TENSIONER	1	
6	4V4-22184-00	BUSH	1	
7	90201-067A0	WASHER, plate	1	
8	97301-06016	BOLT	1	
9	92901-06700	WASHER, wave	1	
10	1LR-2174F-00	GUARD, radiator	1	
11	95021-08012	BOLT, flange	2	
12	1W1-28135-10	SPANNER, special	1	



1LR100-6150

C4

FIG. 16 FENDER

REF. NO.	PART NO.	DESCRIPTION	Q'TY	REMARKS
1	5X2-21511-10	FENDER, front	1	clean white
2	90119-06063	BOLT, with washer	4	
3	22W-21523-00	PLATE 1	1	
4	90209-06187	WASHER	2	
5	22W-21611-10	FENDER, rear	1	clean white
6	92502-06016	SCREW, pan head	3	
7	92990-06100	WASHER, spring	3	
8	90201-065F3	WASHER, plate	3	
9	90201-08730	WASHER, plate	2	
10	95801-08025	BOLT, flange	1	
11	95801-08020	BOLT, flange	1	
12	90185-08113	NUT, self-locking	2	
13	39K-21620-00	MUD GUARD COMP.	1	
14	4V0-21621-00	.FLAP	1	
15	437-83936-00	BAND, switch cord	1	

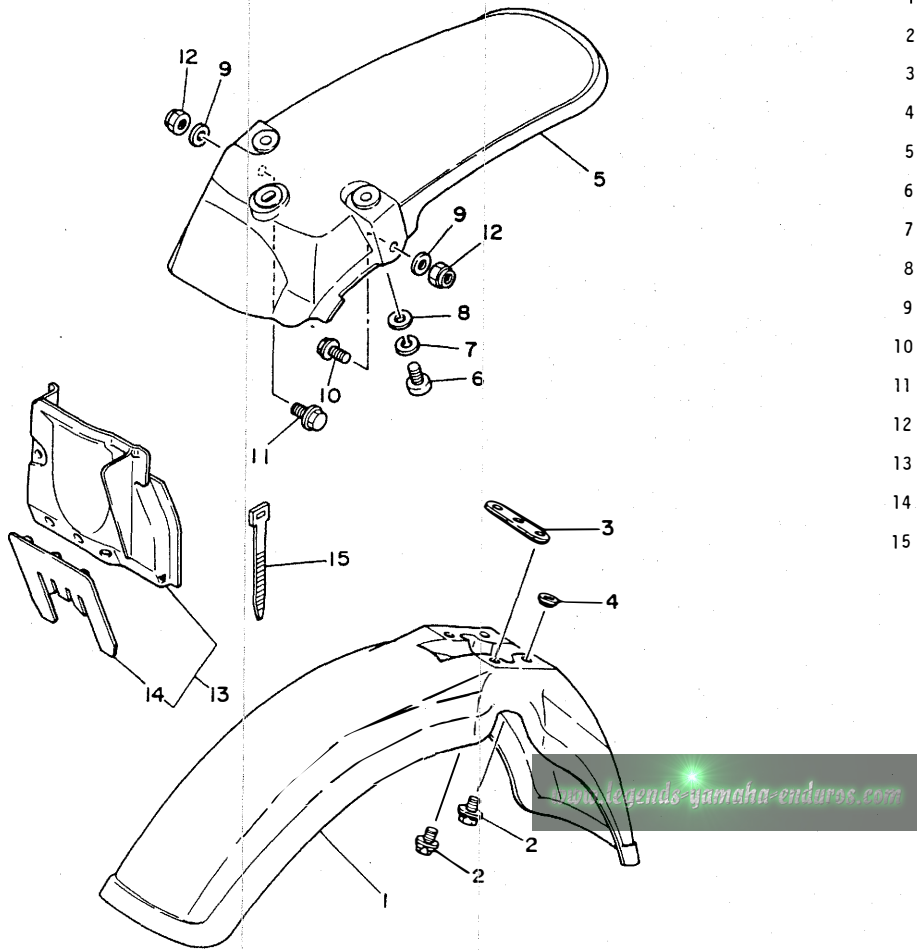

22W100-3171

FIG. 17 SIDE COVER

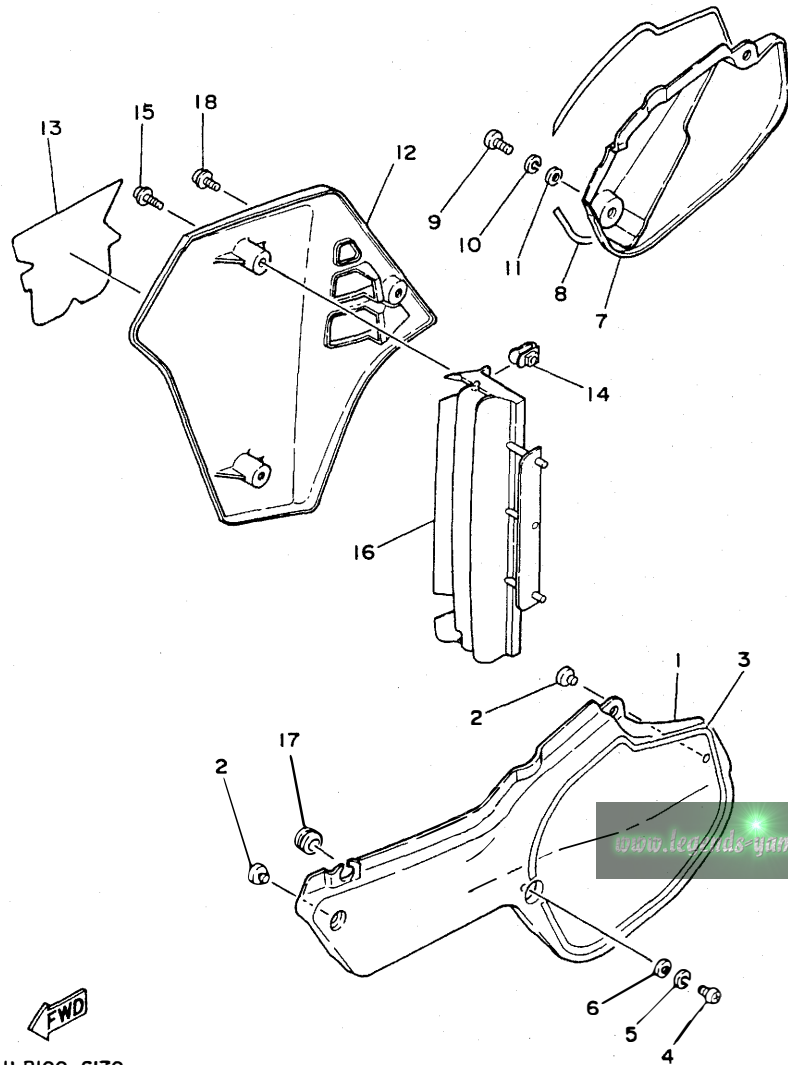

REF. NO.	PART NO.	DESCRIPTION	Q'TY	REMARKS
1	39K-21711-11	COVER, side 1	1	clean white
2	22W-24181-00	DAMPER, locating 1	2	
3	1LR-2173L-00	GRAPHIC SET 1	1	
4	92501-06014	SCREW, pan head	2	
5	92990-06100	WASHER, spring	2	
6	90201-06571	WASHER, plate	2	
7	39K-21721-10	COVER, side 2	1	clean white
8	1LR-2174L-00	GRAPHIC SET 2	1	
9	92501-06014	SCREW, pan head	2	
10	92990-06100	WASHER, spring	2	
11	90201-06571	WASHER, plate	2	
12	1LR-21741-00	COVER, side 4	1	chappy red
13	1LR-2173F-00	GRAPHIC 2	1	
14	22W-21791-00	NUT	2	
15	90159-05101	SCREW, with washer	2	
16	1LR-2172A-00	PANEL 1	1	
17	90480-12053	GROMMET	1	
18	90159-06013	SCREW, with washer	1	

  
ILR100-6170

**C6**

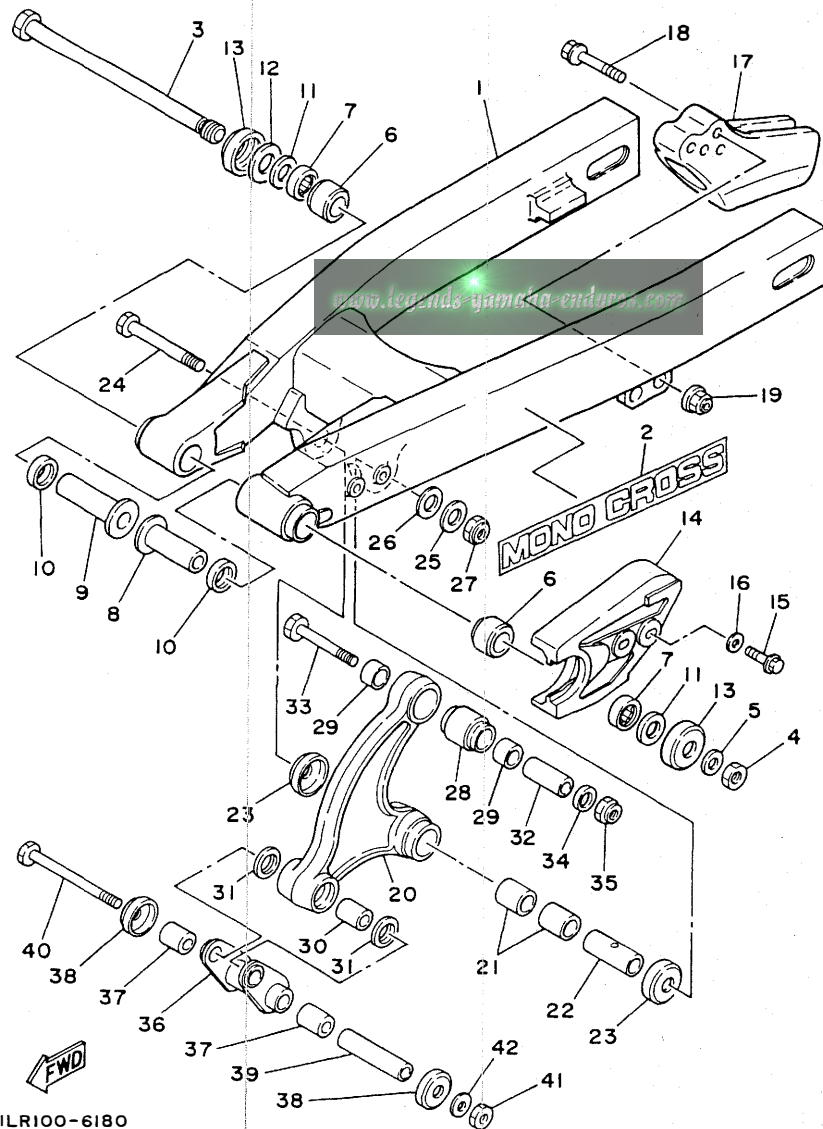

ILR100-6180

FIG. 18 REAR ARM

REF. NO.	PART NO.	DESCRIPTION	Q'TY	REMARKS
1	1LR-22110-00	REAR ARM COMP.	1	
2	5X1-2218A-00	EMBLEM, rear arm	2	
3	4V1-22141-00	SHAFT, pivot	1	
4	90185-12119	NUT, self-locking	1	
5	90201-12469	WASHER, plate	1	
6	90385-17042	BUSH	2	
7	93317-21746	BEARING, cylindrical	2	
8	90387-127J8	COLLAR	1	
9	90387-127J7	COLLAR	1	
10	93109-17048	OIL SEAL	2	
11	90201-191J4	WASHER, plate	2	
12	401-22127-00	SHIM	1	
13	401-22128-01	SEAL, guard	2	
14	1LR-22151-00	SEAL, guard	1	
15	95026-06025	BOLT, flange	2	
16	90201-06067	WASHER, plate	2	
17	39K-22199-00	SUPPORT, chain	1	
18	95821-08045	BOLT, flange	2	
19	90185-08113	NUT, self-locking	2	
20	39K-2217A-00	ARM, relay	1	
21	90384-18190	BUSH, bimetal formed	2	
22	90380-12094	BUSH, solid	1	
23	5X6-22129-00	COVER, thrust 2	2	
24	90109-100E4	BOLT	1	
25	90201-100E9	WASHER, plate	1	
26	90201-120A5	WASHER, plate	1	
27	90185-10110	NUT, self-locking	1	
28	22W-22124-00	BUSH 2	1	



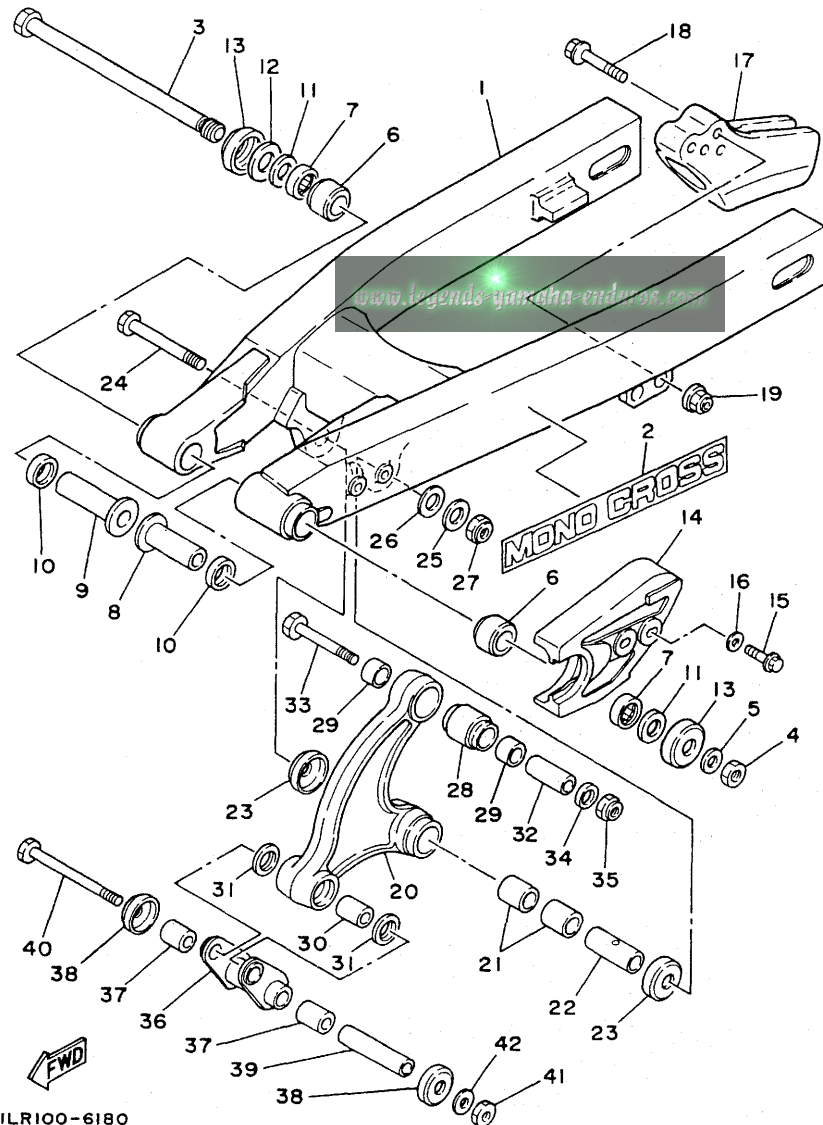

ILR100-6180

FIG. 18 REAR ARM

REF. NO.	PART NO.	DESCRIPTION	Q'TY	REMARKS
29	90380-16109	BUSH, solid	2	
30	90383-16023	BUSH, formed	1	
31	93109-16035	OIL SEAL	2	
32	90387-10660	COLLAR	1	
33	90109-10689	BOLT	1	
34	92990-10600	WASHER, plate	1	
35	90185-10110	NUT, self-locking	1	
36	22W-2217F-00	ROD, connecting 1	1	
37	90383-16023	BUSH, formed	2	
38	22W-22129-00	COVER, thrust 2	2	
39	90387-10569	COLLAR	1	
40	90109-10688	BOLT	1	
41	90185-10110	NUT, self-locking	1	
42	92990-10600	WASHER, plate	1	

SEAL KIT INT. 43K-W222A-01

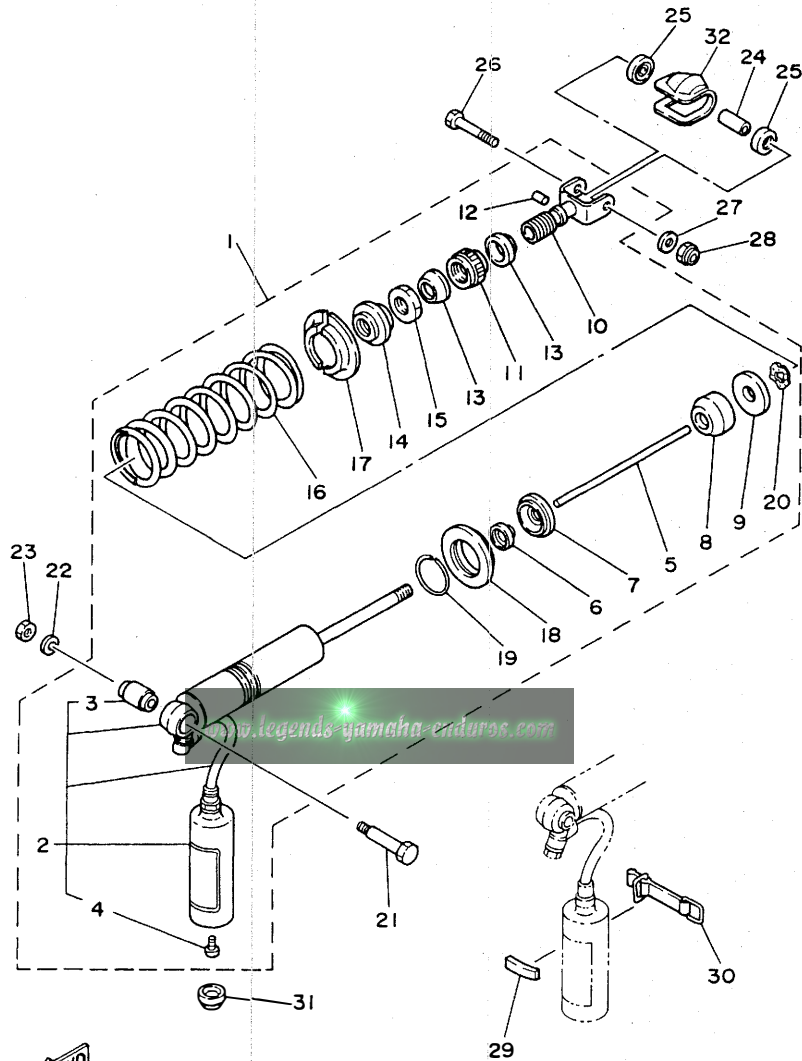

39K100-4190

FIG. 19 REAR SUSPENSION

REF. NO.	PART NO.	DESCRIPTION	Q'TY	REMARKS
1	39K-22210-00-6W	SHOCK ABSORBER ASSY, rear	1	native red
2	39K-22401-00	.DAMPER SUB ASSY	1	
3	2X6-22216-00	..BUSH, rear shock absorber	1	
4	98501-04005	..SCREW, pan head	1	
5	22W-22489-00	.ROD, push	1	
6	29L-22475-00	.SEAL, dust	1	
7	39K-22472-00	.CAP, case	1	
8	5X2-22493-00	.BUMP, stop	1	
9	5X2-22228-00	.SUPPORT, bump stop	1	
10	22W-22409-00	.UPPER BRACKET SUB ASSY	1	
11	3R4-22497-00	.NUT, adjusting	1	
12	93604-26132	.PIN, dowel	1	
13	3R4-22221-01	.COVER	1	
14	3R4-22213-00	.SEAT, spring upper	1	
15	90170-20213	.NUT	1	
16	22W-22212-20-6W	.SPRING (K=3.6)	1	native red
17	22W-22214-00	.GUIDE, spring 1	2	
18	22W-22223-00	.SEAT, spring lower	1	
19	93440-42101	.CIRCLIP	1	
20	90206-12082	.WASHER, wave	1	
21	90109-10729	BOLT	1	
22	92990-10600	WASHER, plate	1	
23	90185-10110	NUT, self-locking	1	
24	90387-10660	COLLAR	1	
25	22W-22129-00	COVER, thrust 2	2	
26	90109-10689	BOLT	1	
27	92990-10600	WASHER, plate	1	
28	90185-10110	NUT, self-locking	1	

C9

FIG. 19 REAR SUSPENSION

REF. NO.	PART NO.	DESCRIPTION	QTY	REMARKS
29	24X-22261-00	DAMPER, sub tank	1	
30	24X-22262-00	HOLDER, sub tank	1	
31	90480-17359	GROMMET	1	
32	22W-22189-00	BOOT, rubber	1	

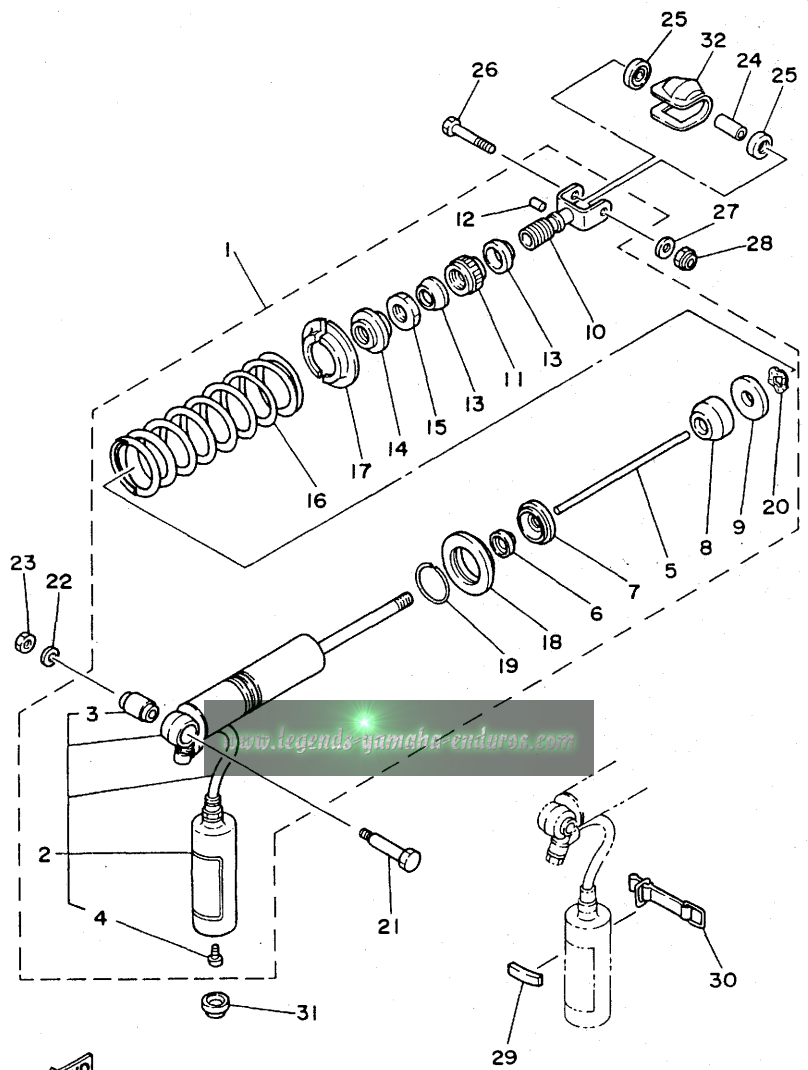

39K100-4190

FIG. 20 STEERING

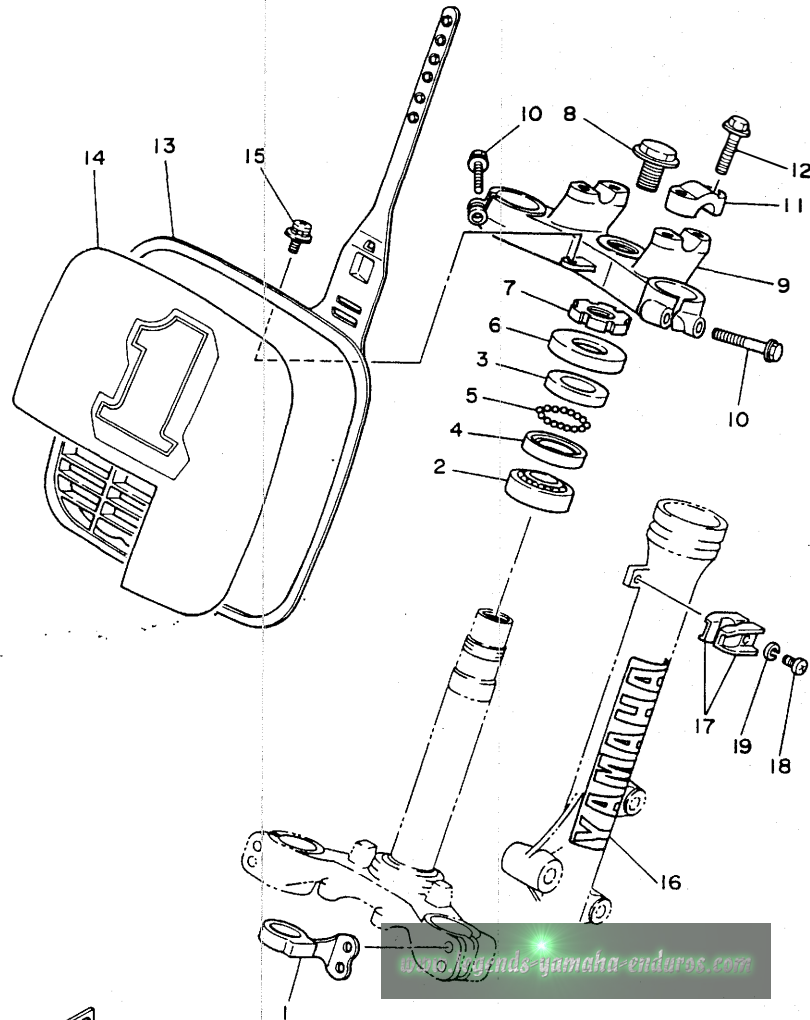

REF. NO.	PART NO.	DESCRIPTION	Q'TY	REMARKS
1	3R4-23389-00	GUIDE, cable	1	
2	93332-00059	BEARING	1	
3	122-23411-00	RACE, ball 1	1	
4	122-23412-00	RACE, ball 2	1	
5	93503-16010	BALL	22	
6	122-23416-00	COVER, ball race 2	1	
7	90179-25033	NUT	1	
8	90105-14137	BOLT, washer based	1	
9	22W-23435-00-98	CROWN, handle	1	low gloss black
10	95801-08035	BOLT, flange	2	
11	1E6-23441-00	HOLDER, handle upper	2	
12	95821-08030	BOLT, flange	4	
13	22W-23485-11	PLATE, number	1	clean white
14	1LR-21785-00	EMBLEM 5	1	
15	90159-06060	SCREW, with washer	1	
16	1LR-23108-00	EMBLEM	2	
17	90465-14242	CLAMP	2	
18	91311-06016	BOLT	2	
19	92901-06600	WASHER, plate	2	



ILR100-6200

FIG. 21 FRONT FORK

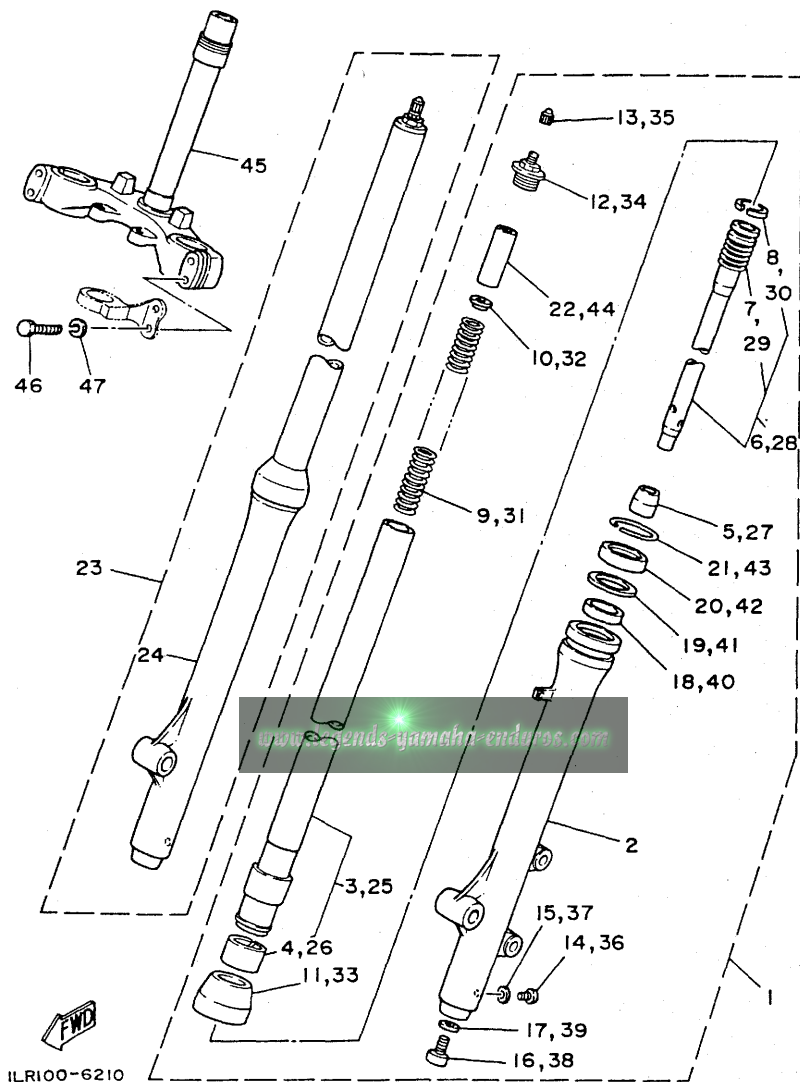

ILR100-6210

REF. NO.	PART NO.	DESCRIPTION	QTY	REMARKS
1	1LR-23102-L0	FRONT FORK ASSY (L.H)	1	
2	1LR-23126-L0	.TUBE, outer 1	1	
3	58T-23110-L0	.INNER TUBE COMP.1	1	
4	22W-2312K-00	..PISTON, front fork	1	
5	39K-23173-00	.SPINDLE, taper	1	
6	39K-23170-L0	.CYLINDER COMP., front fork	1	
7	509-23151-L0	..SPRING, rebound	1	
8	22W-23157-L0	..RING, piston	1	
9	39K-23141-00	.SPRING, front fork (K=0.23)	1	
10	583-23142-00	.SEAT, spring upper	1	
11	22W-23144-L0	.SEAL, dust	1	
12	58T-23111-L0	.BOLT, cap	2	
13	58T-23184-L0	.CAP, air valve	1	
14	122-23119-01	.PLUG, drain	1	
15	122-23129-00	.GASKET, drain plug	1	
16	278-23181-50	.BOLT, hexagon socket head	1	
17	509-23158-L0	.GASKET	1	
18	22W-23125-L0	.METAL, slide 1	1	
19	22W-23146-L0	.WASHER, oil seal	1	
20	22W-23145-L0	.OIL SEAL	1	
21	22W-23153-L0	.RING, snap	1	
22	58T-23118-L0	.SPACER	1	
23	58T-23103-L0	FRONT FORK ASSY (R.H)	1	
24	39K-23136-L0	.TUBE, outer 2	1	
25	58T-23110-L0	.INNER TUBE COMP.1	1	
26	22W-2312K-00	..PISTON, front fork	1	
27	39K-23173-00	.SPINDLE, taper	1	
28	39K-23170-L0	.CYLINDER COMP., front fork	1	

FIG. 21 FRONT FORK

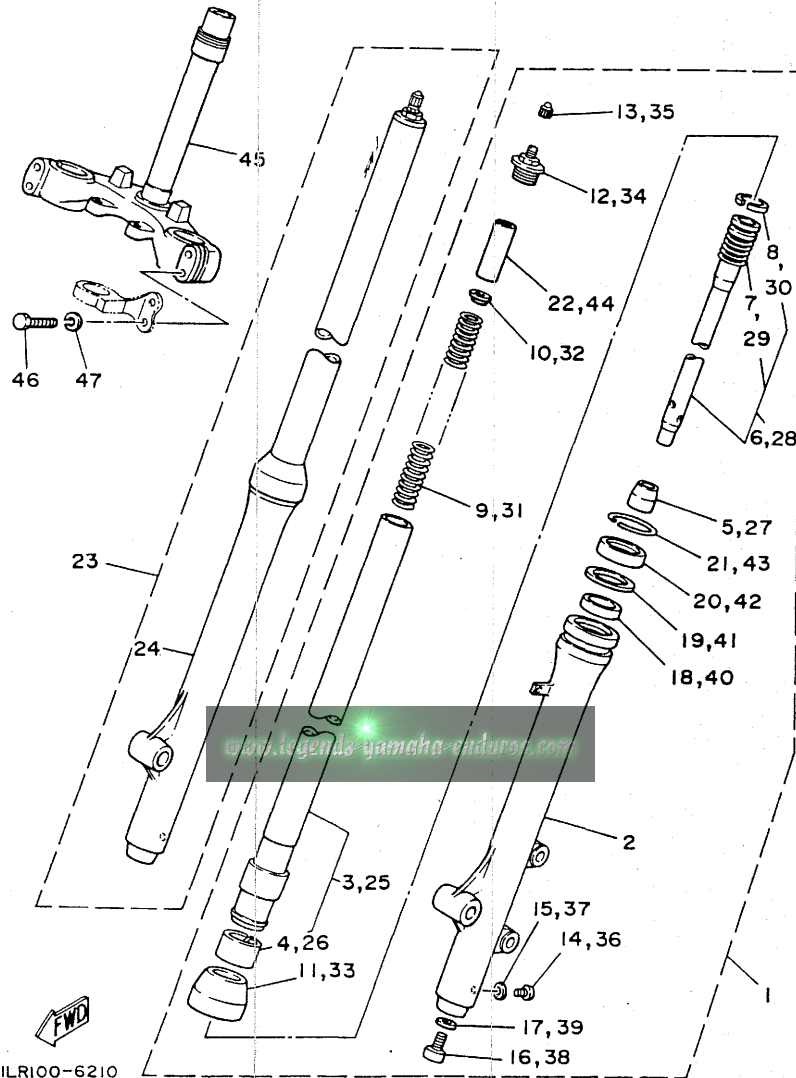

REF. NO.	PART NO.	DESCRIPTION	Q'TY	REMARKS
29	509-23151-L0	..SPRING, rebound	1	
30	22W-23157-L0	..RING, piston	1	
31	39K-23141-00	..SPRING, front fork (K=0.23)	1	
32	583-23142-00	..SEAT, spring upper	1	
33	22W-23144-L0	..SEAL, dust	1	
34	58T-23111-L0	..BOLT, cap	1	
35	58T-23184-L0	..CAP, air valve	1	
36	122-23119-01	..PLUG, drain	1	
37	122-23129-00	..GASKET, drain plug	1	
38	278-23181-50	..BOLT, hexagon socket head	1	
39	509-23158-L0	..GASKET	1	
40	22W-23125-L0	..METAL, slide 1	1	
41	22W-23146-L0	..WASHER, oil seal	1	
42	22W-23145-L0	..OIL SEAL	1	
43	22W-23153-L0	..RING, snap	1	
44	58T-23118-L0	..SPACER	1	
45	39K-23340-L0	UNDER BRACKET COMP.	1	
46	97321-08040	BOLT	4	
47	92990-08100	WASHER, spring	4	

ILR100-6210

FIG. 22 FUEL TANK

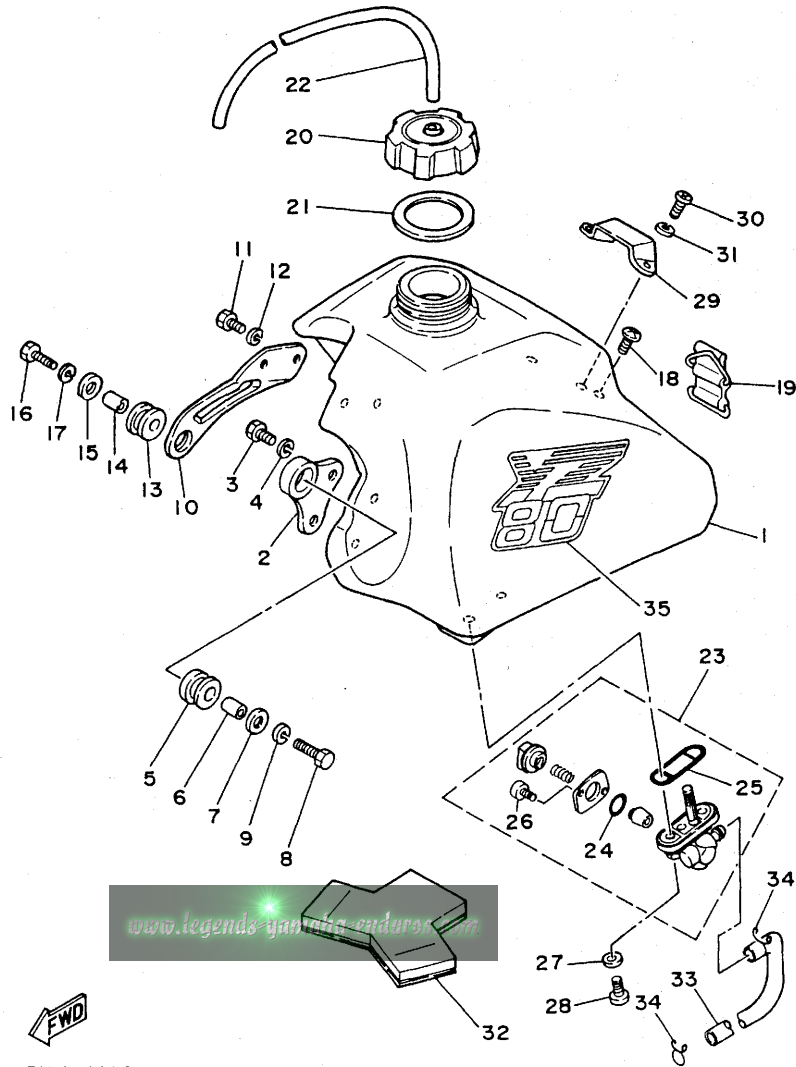

REF. NO.	PART NO.	DESCRIPTION	Q'TY	REMARKS
1	1LR-24110-00	FUEL TANK COMP.	1	clean white
2	1LR-24157-00	STAY, fuel tank 1	1	
3	97301-06012	BOLT	2	
4	92990-06100	WASHER, spring	2	
5	90480-18290	GROMMET	1	
6	90387-07598	COLLAR	1	
7	90201-06072	WASHER, plate	1	
8	97321-06030	BOLT	1	
9	92990-06100	WASHER, spring	1	
10	22W-24158-00	STAY, fuel tank 2	1	
11	97301-06012	BOLT	1	
12	92990-06100	WASHER, spring	1	
13	90480-18290	GROMMET	1	
14	90387-07598	COLLAR	1	
15	90201-06072	WASHER, plate	1	
16	97321-06030	BOLT	1	
17	92990-06100	WASHER, spring	1	
18	98903-06018	SCREW, bind	1	
19	59V-24173-00	BAND, tank fitting 1	1	
20	5X7-24611-01	BODY, cap	1	
21	5X7-24612-00	GASKET, cap	1	
22	90445-09304	HOSE	1	
23	1LR-24500-00	FUEL COCK ASSY 1	1	
24	4X8-24534-00	.SEAL, cock	1	
25	4X8-24512-00	.GASKET	1	
26	97801-03008	.SCREW, pan head	1	
27	90202-06010	WASHER, plate	2	
28	90149-06011	SCREW	2	

www.legendsyaning-enduros.com



ILR100-6220

C14

FIG. 22 FUEL TANK

REF. NO.	PART NO.	DESCRIPTION	Q'TY	REMARKS
29	5X7-2412F-00	BRACKET, seat	1	
30	92501-06012	SCREW, pan head	2	
31	92990-06100	WASHER, spring	2	
32	22W-24183-00	DAMPER, locating 3	1	
33	1LR-24311-00	PIPE, fuel 1	1	
34	90467-10008	CLIP	2	
35	1LR-24254-00	GRAPHIC, fuel tank 7	1	

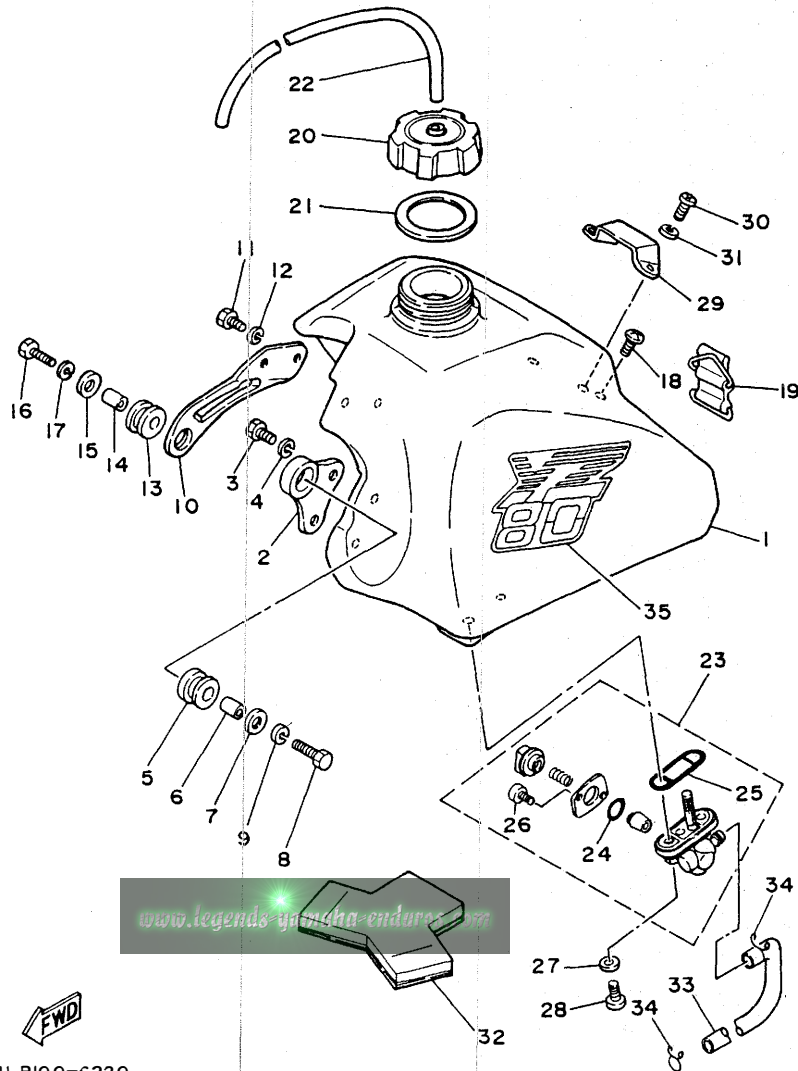

www.legends-yamaha-enduro.com



1LR100-6220

C15



FIG. 23 SEAT

REF. NO.	PART NO.	DESCRIPTION	Q'TY	REMARKS
1	1LR-24770-00	SEMI-DOUBLE SEAT ASSY	1	
2	1LR-24731-00	.COVER, seat	1	
3	22W-24741-00	.PAD, seat	2	

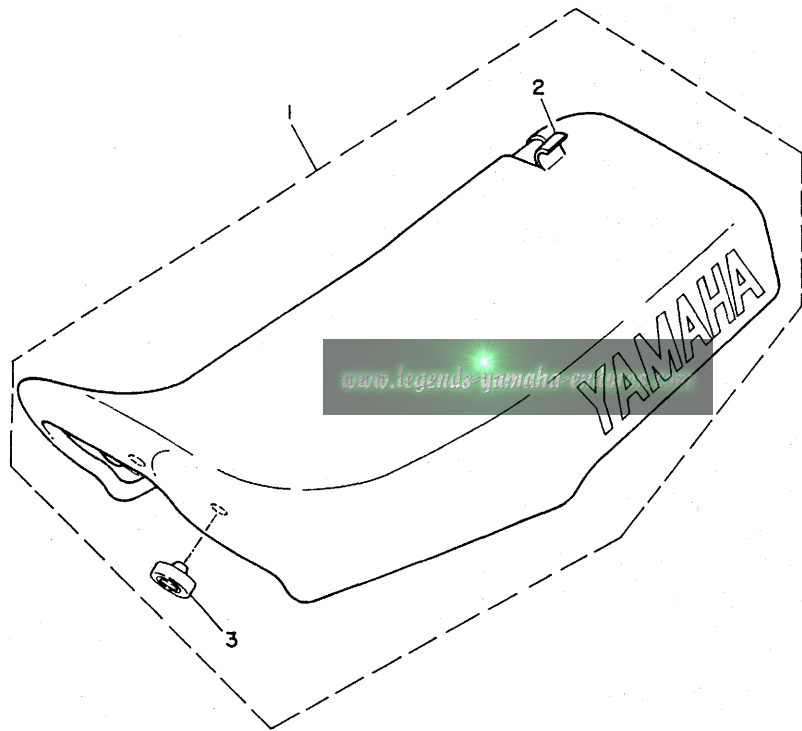
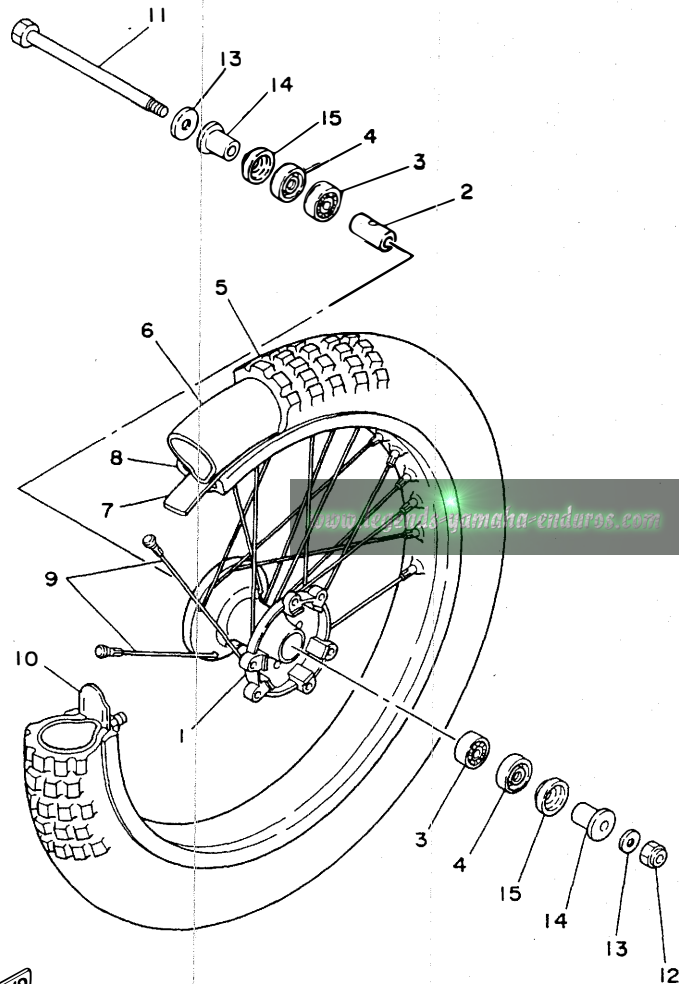

FIG. 24 FRONT WHEEL



REF. NO.	PART NO.	DESCRIPTION	Q'TY	REMARKS
1	1LR-25111-00-98	HUB, front	1	low gloss black
2	90560-12257	SPACER	1	
3	93306-00105	BEARING (B6001)	2	
4	93106-18013	OIL SEAL	2	
5	94108-173G5	TIRE (80/80-17)	1	UR bridgestone
	94107-177H8	TIRE (70/100-17)	1	UR inoue
6	94208-17238	TUBE (80/80-17)	1	UR bridgestone
	94230-17214	TUBE (3.00-17)	1	UR dunlop
7	94327-17103	BAND, rim (2.75-17)	1	UR bridgestone
	94327-17079	BAND, rim (2.75-17)	1	UR inoue
8	94414-17428	RIM (1.40-17)	1	
9	1LR-25104-00	SPOKE SET, front	1	
10	1T1-25194-00	SPACER, bead	1	
11	22W-25181-01	AXLE, wheel	1	
12	90185-12046	NUT, self-locking	1	
13	90201-12174	WASHER, plate	2	
14	90387-126F8	COLLAR	2	
15	462-25118-00	COVER, hub dust	2	



ILR100-6240

D3

FIG. 25 FRONT BRAKE CALIPER

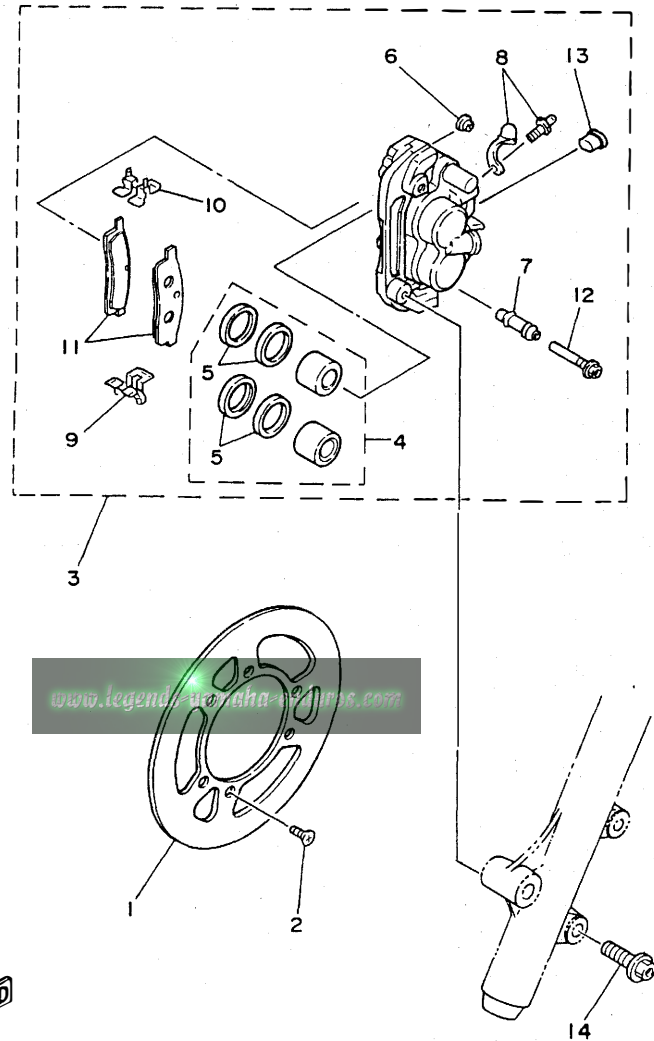

REF. NO.	PART NO.	DESCRIPTION	Q'TY	REMARKS
1	1LR-25831-00	DISC, brake (RIGHT)	1	
2	92701-06012	SCREW, flat head	6	
3	1LR-25810-00	CALIPER ASSY (RIGHT)	1	
4	11R-W0057-00	.PISTON ASSY, caliper	1	
5	1LR-W0047-00	..CALIPER SEAL KIT	1	
6	5R2-25917-00	.BOOT, caliper	1	
7	56A-25937-00	.BOOT 2	1	
8	51L-W0048-00	.BLEED SCREW KIT	1	
9	56A-25919-00	.SUPPORT, pad	1	
10	56A-25919-10	.SUPPORT, pad	1	
11	1LR-W0046-00	.BRAKE PAD KIT, rear	1	
12	56A-25926-00	.BOLT	1	
13	34X-25845-00	.CAP, indicator	1	
14	95811-08035	BOLT, flange	2	



ILR100-6250

**D4**

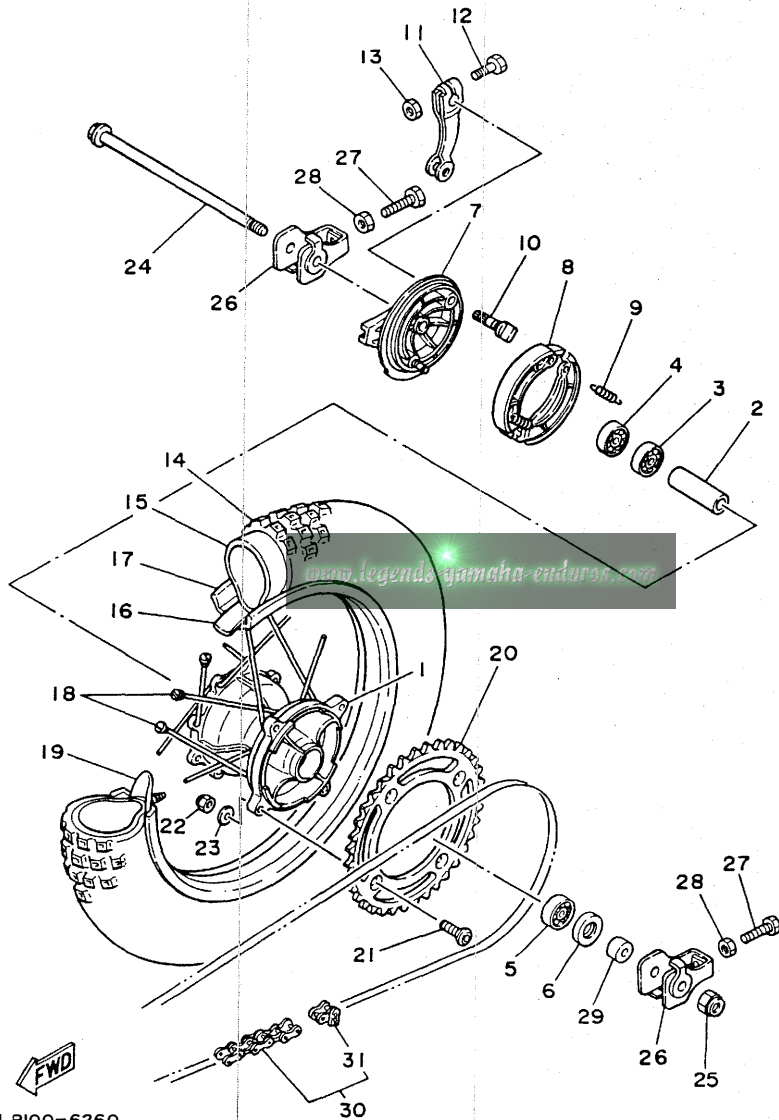

ILR100-6260

FIG. 26 REAR WHEEL

REF. NO.	PART NO.	DESCRIPTION	Q'TY	REMARKS
1	39K-25311-00-98	HUB, rear	1	low gloss black
2	90560-12256	SPACER	1	
3	93306-00108	BEARING	1	
4	93306-00105	BEARING (B6001)	1	
5	93306-30101	BEARING (B6301)	1	
6	93106-20002	OIL SEAL	1	
7	39K-25321-00-98	PLATE, brake shoe	1	low gloss black
8	39K-25130-00	BRAKE SHOE COMP.	2	
9	90506-14081	SPRING, tension	2	
10	3R0-25351-00	CAMSHAFT	1	
11	3R0-25355-11	LEVER, camshaft	1	
12	90101-06278	BOLT	1	
13	95301-06600	NUT	1	
14	94111-143G4	TIRE (110/80-14)	1	bridgestone
15	94211-14237	TUBE (110/80-14)	1	bridgestone
16	94320-14096	BAND, rim (2.00-14)	1	
17	94416-14375	RIM (1.60-14)	1	
18	39K-25304-00	SPOKE SET, rear	1	
19	5X2-25394-00	SPACER, bead	1	
20	39K-25446-00	SPROCKET, driven (46T)	1	STD
	39K-25444-00	SPROCKET, driven (44T)	1	AP
	39K-25448-00	SPROCKET, driven (48T)	1	AP
	39K-25450-00	SPROCKET, driven (50T)	1	AP
21	90109-08706	BOLT	4	
22	95611-08100	NUT, u	4	
23	90201-081A6	WASHER, plate	4	
24	1LR-25381-00	AXLE, wheel	1	
25	90185-12093	NUT, self-locking	1	

D5

FIG. 26 REAR WHEEL

M/R 86001 JAN '86

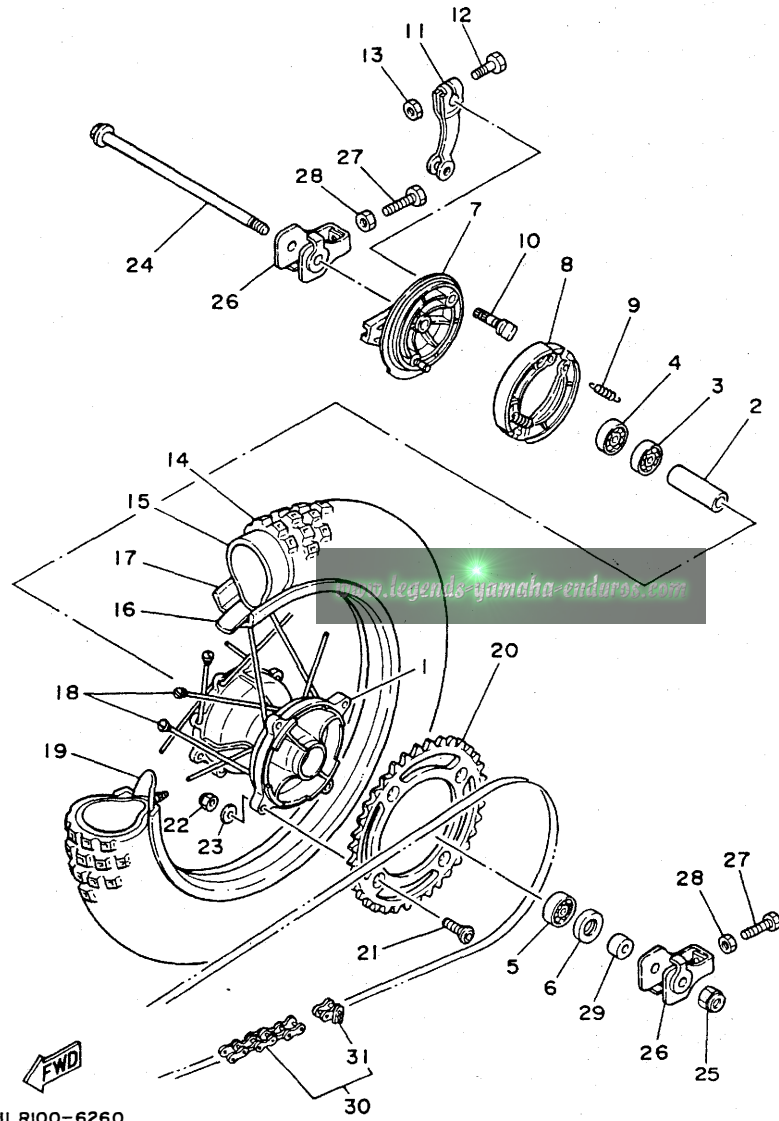

REF. NO.	PART NO.	DESCRIPTION	Q'TY	REMARKS
26	1LR-25388-00 <sup>07</sup>	PULLER, chain 1	2	
27	90101-08475	BOLT	2	
28	95301-08700	NUT	2	
29	90387-127J9	COLLAR	1	
30	94580-24112	CHAIN, drive (DID428 112L)	1	
31	94680-24001	.JOINT, chain (DID 428)	1	

ILRI00-6260

D6

FIG. 27 STEERING HANDLE. CABLE

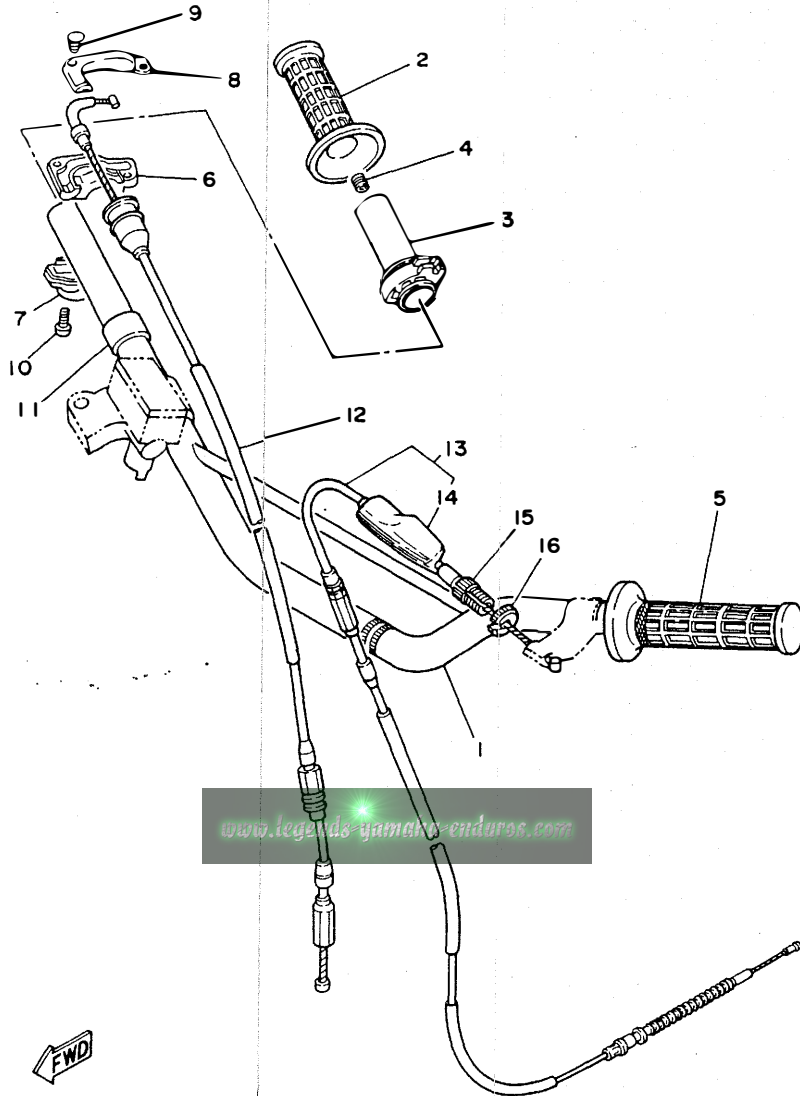

REF. NO.	PART NO.	DESCRIPTION	Q'TY	REMARKS
1	22W-26111-00	HANDLEBAR	1	
2	29U-26242-00	GRIP (R.H)	1	
3	22W-26243-00	TUBE, throttle guide	1	
4	688-82535-00	GROMMET	1	
5	4V4-26241-01	GRIP (L.H)	1	
6	5X2-26281-00	CAP, grip upper	1	
7	322-26282-00	CAP, grip lower	1	
8	5X2-2628H-01	CAP, wire	1	
9	98706-04012	SCREW, flat head	2	
10	98506-05016	SCREW, pan head	2	
11	90387-22647	COLLAR	1	
12	22W-26311-00	CABLE, throttle 1	1	
13	39K-26335-00	CABLE, clutch	1	
14	382-26372-01	.COVER, handle lever 1	1	
15	90123-08013	BOLT	1	
16	90179-08148	NUT	1	



ILR100-6270

D7

FIG. 28 FRONT MASTER CYLINDER

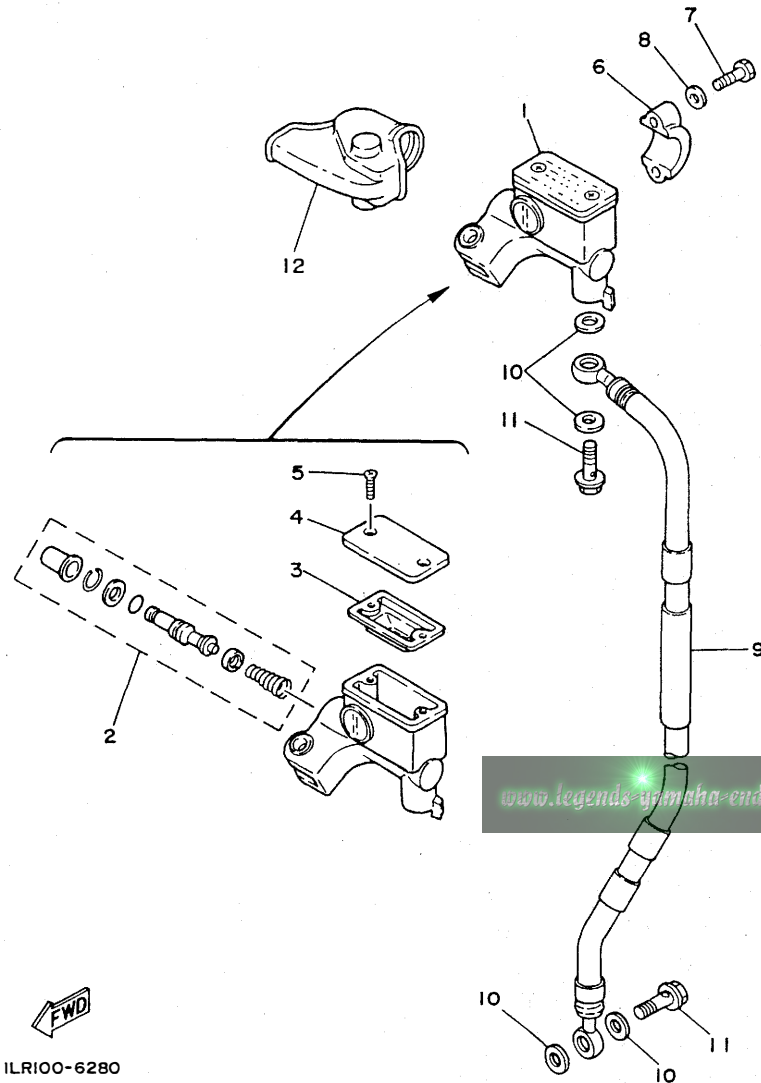

REF. NO.	PART NO.	DESCRIPTION	Q'TY	REMARKS
1	56A-25870-00	MASTER CYLINDER SUB ASSY	1	
2	56A-W0041-00	.CYLINDER KIT, master	1	
3	56A-25854-00	.DIAPHRAGM, reservoir	1	
4	56A-25852-00	.CAP, reservoir	1	
5	98706-04012	.SCREW, flat head	2	
6	56A-25867-00	BRACKET, master cylinder	1	
7	97326-06025	BOLT	2	
8	92906-06600	WASHER, plate	2	
9	1LR-25872-00	HOSE, brake 1	1	
10	90201-10118	WASHER, plate	4	
11	90401-10034	BOLT, union	2	
12	56A-26372-00	COVER, handle lever 1	1	



ILR100-6280

D8

FIG. 29 STAND, FOOTREST

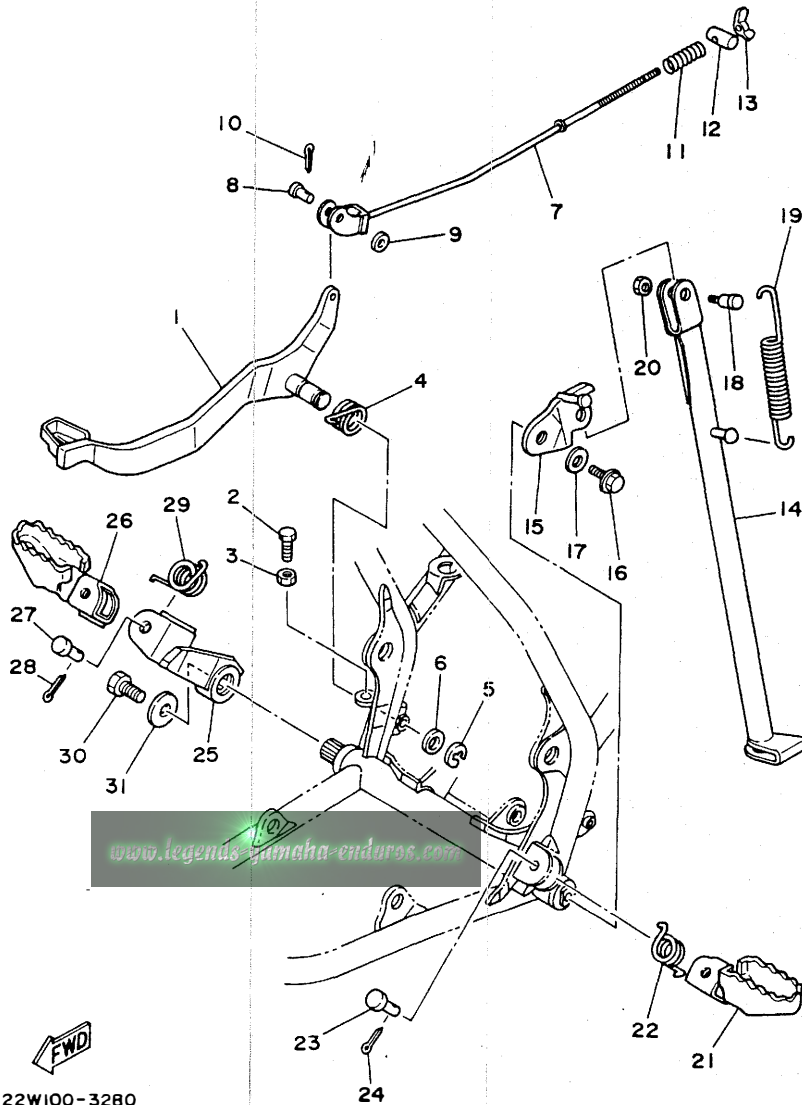

REF. NO.	PART NO.	DESCRIPTION	Q'TY	REMARKS
1	1LR-27211-00	PEDAL, brake	1	
2	97301-06012	BOLT	1	
3	95301-06700	NUT	1	
4	90508-32468	SPRING, torsion	1	
5	99002-09600	CIRCLIP	1	
6	92902-12600	WASHER, plate	1	
7	39K-27231-00	ROD, brake	1	
8	90240-06040	PIN, clevis	1	
9	92901-06200	WASHER, plain	1	
10	91401-20015	PIN, cotter	1	
11	90501-10245	SPRING, compression	1	
12	90249-12008	PIN	1	
13	90175-06016	NUT, wing	1	
14	22W-27311-00-R4	STAND, side	1	black
15	22W-27321-00	BRACKET, side stand	1	
16	95821-10016	BOLT, flange	1	
17	90201-102A2	WASHER, plate	1	
18	90109-08666	BOLT	1	
19	90506-28100	SPRING, tension	1	
20	95301-08700	NUT	1	
21	22W-27411-00-90	FOOTREST 1	1	uni chrome (black)
22	90508-20023	SPRING, torsion	1	
23	90240-08097	PIN, clevis	1	
24	91401-25015	PIN, cotter	1	
25	5X2-27422-01-33	BRACKET, footrest 2	1	yamaha black
26	22W-27421-00-90	FOOTREST 2	1	uni chrome (black)
27	90240-08097	PIN, clevis	1	
28	91401-25015	PIN, cotter	1	

22W100-3280  



FIG. 29 STAND. FOOTREST

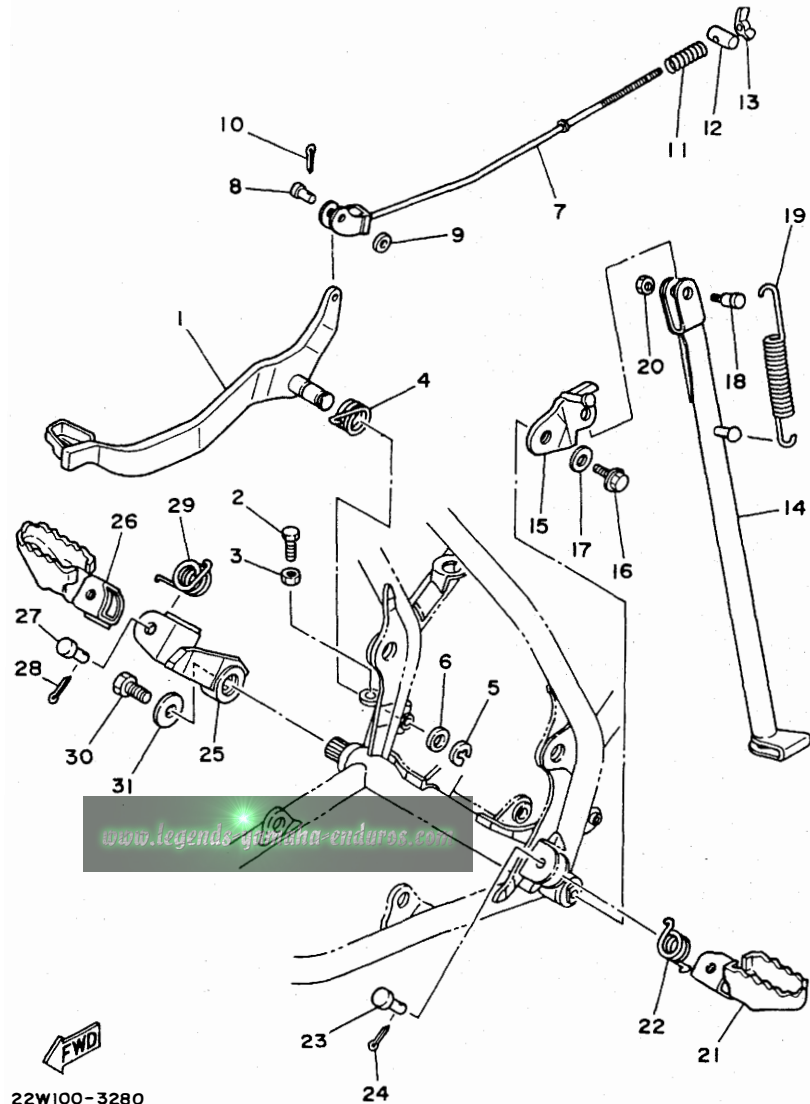

REF. NO.	PART NO.	DESCRIPTION	Q'TY	REMARKS
29	90508-20023	SPRING, torsion	1	
30	97311-10022	BOLT	1	
31	90201-10144	WASHER, plate	1	

www.legends-gibana-enduros.com



22W100-3280

D10

FIG. 30 GENERATOR

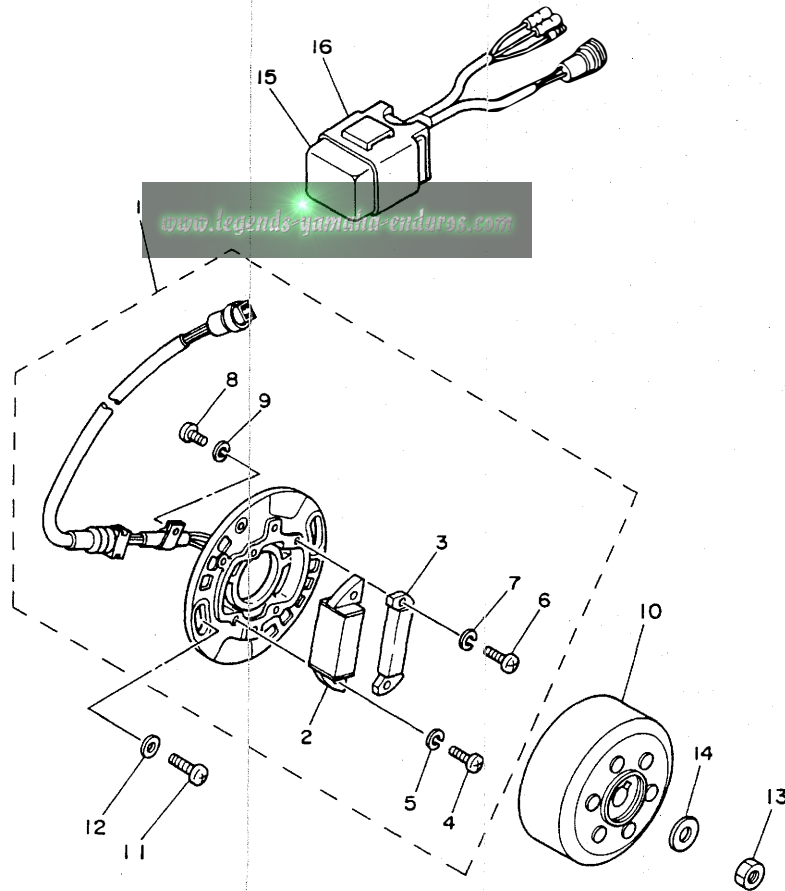

REF. NO.	PART NO.	DESCRIPTION	Q'TY	REMARKS
1	1LR-85510-20	STATOR ASSY	1	
2	58T-85541-20	.COIL, charge	1	
3	58T-85580-20	.COIL, pulser	1	
4	98511-04025	.SCREW, pan head	2	
5	92902-04100	.WASHER, spring	2	
6	98501-04014	.SCREW, pan head	2	
7	92902-04100	.WASHER, spring	2	
8	98506-04008	.SCREW, pan head	1	
9	92902-04100	.WASHER, spring	1	
10	39K-85550-20	ROTOR ASSY	1	
11	92501-06014	SCREW, pan head	2	
12	92901-06600	WASHER, plate	2	
13	95311-10600	NUT	1	
14	90201-10591	WASHER, plate	1	
15	1LR-85540-20	C.D.I. UNIT ASSY	1	
16	2A7-85546-00	BAND	1	



ILR100-6300

D11

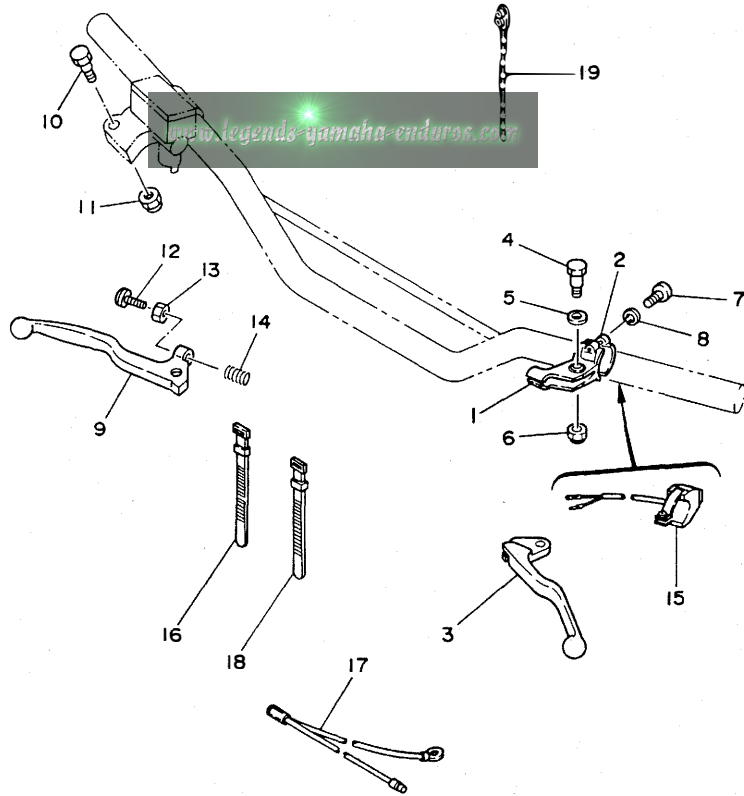

FIG. 31 HANDLE SWITCH. LEVER

REF. NO.	PART NO.	DESCRIPTION	Q'TY	REMARKS
1	38V-82911-00	HOLDER, lever 1	1	
2	38V-82913-00	HOLDER, lever lower 1	1	
3	23X-83912-00	LEVER 1	1	
4	90109-06797	BOLT	1	
5	90201-082A9	WASHER, plate	1	
6	95606-06100	NUT, u	1	
7	98506-05018	SCREW, pan head	2	
8	92906-05100	WASHER, spring	2	
9	55Y-83922-00	LEVER 2	1	
10	90109-06577	BOLT	1	
11	95606-06100	NUT, u	1	
12	90149-06153	SCREW	1	
13	90170-06010	NUT	1	
14	90501-10312	SPRING, compression	1	
15	22W-83976-00	SWITCH, handle 1	1	
16	437-83936-00	BAND, switch cord	2	
17	5X1-82519-00	WIRE, earth lead	1	
18	437-83936-10	BAND, switch cord	1	
19	90464-20031	CLAMP	1	



ILR100-6310

D12

FIG. 32 ELECTRICAL 1

REF. NO.	PART NO.	DESCRIPTION	Q'TY	REMARKS
1	39K-82310-40	IGNITION COIL ASSY	1	
2	92501-06020	SCREW, pan head	2	
3	92990-06100	WASHER, spring	2	
4	1M1-82370-21	PLUG CAP ASSY	1	with noise suppressor

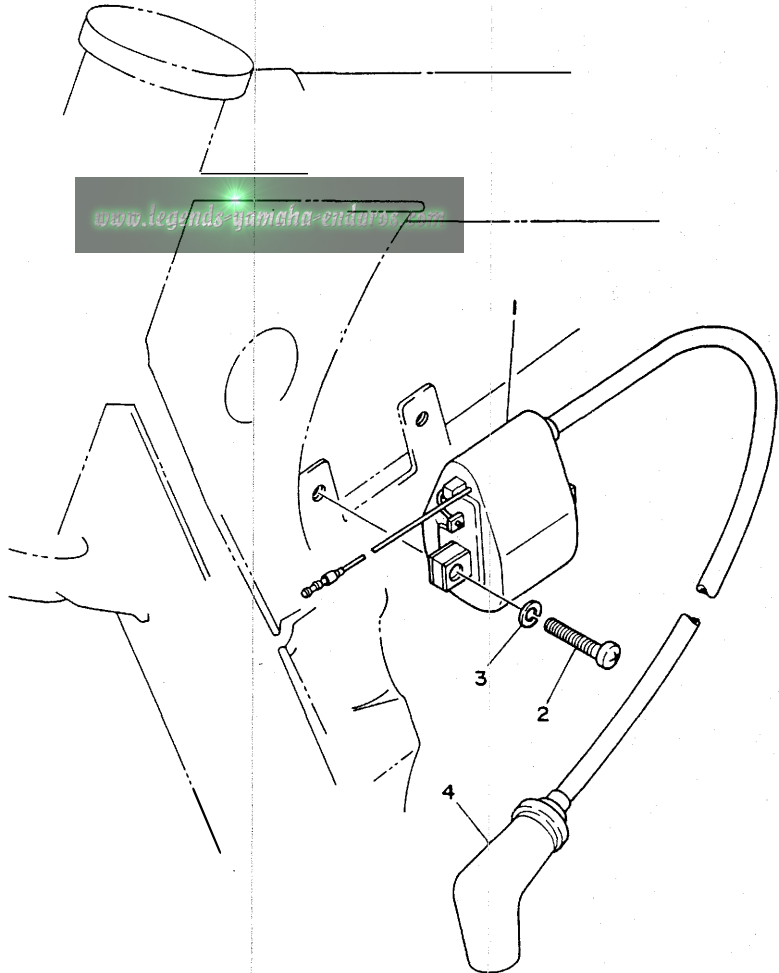

22W100-3291

**D13**

FIG. 33 ALTERNATE 1 (CHASSIS)

REF. NO.	PART NO.	DESCRIPTION	Q'TY	REMARKS
1	39K-23141-20	SPRING, front fork (K=0.25)	2	AP (hard)
2	22N-23118-L0	SPACER	2	AP
3	22W-22212-00-6W	SPRING (K=3.25)	1	UR AP native red (soft)
	22W-22212-30-6W	SPRING (K=3.80)	1	UR AP native red (hard)

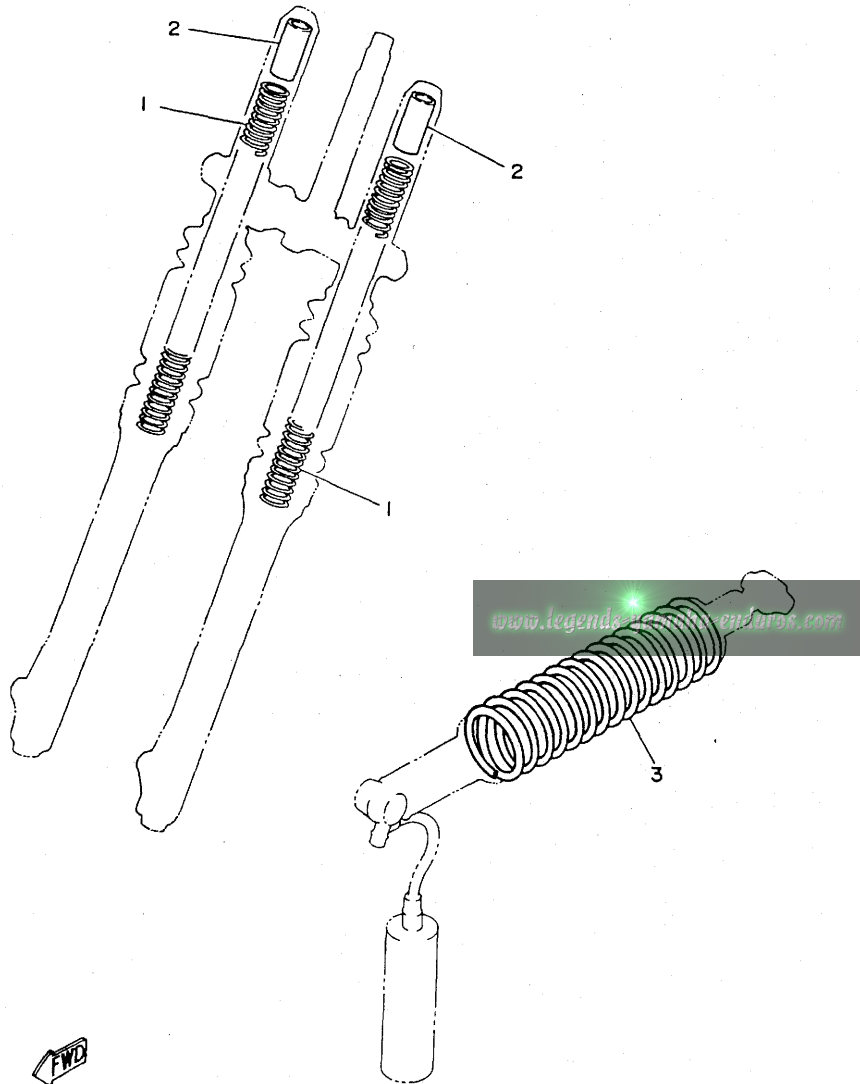

58T100-5310

D14

FIG. 34 REPAIR KIT

REF. NO.	PART NO.	DESCRIPTION	Q'TY	REMARKS
1	58T-11630-A0	PISTON ASSY (STD)	1	AP
2	58T-11631-00-94	.PISTON (STD)	1	
3	39K-11611-00	.RING, piston	1	
4	4V1-11633-00	.PIN, piston	1	
5	5X2-11634-00	.CLIP, piston pin	2	
6	58T-11630-E0	PISTON ASSY (1ST O/S)	1	AP
7	58T-11635-00	.PISTON (0.25MM O/S)	1	
8	39K-11611-10	.RING, piston	1	
9	4V1-11633-00	.PIN, piston	1	
10	5X2-11634-00	.CLIP, piston pin	2	
11	58T-11630-F0	PISTON ASSY (2ND O/S)	1	AP
12	58T-11636-00	.PISTON (0.50MM O/S)	1	
13	39K-11611-20	.RING, piston	1	
14	4V1-11633-00	.PIN, piston	1	
15	5X2-11634-00	.CLIP, piston pin	2	
16	39K-11650-00	CONNECTING ROD ASSY	1	AP
17	39K-11651-00	.ROD, connecting	1	
18	93310-418M6	.BEARING, cylindrical	1	
19	4V0-11681-00	.PIN, crank 1	1	
20	90209-18112	.WASHER	2	
21	93310-312M5	.BEARING, cylindrical	1	

[www.legends-yamaha-enduros.com](http://www.legends-yamaha-enduros.com)

www.legemis-yamaha-enduros.com

NUMERICAL INDEX

PART NO.	GRID NO.	PART NO.	GRID NO.	PART NO.	GRID NO.	PART NO.	GRID NO.	PART NO.	GRID NO.	PART NO.	GRID NO.
56A-W0041-00	D- 8	22W-12463-00	B- 5	39K-14458-00	B- 6	174-17461-20	B-15	22W-22212-00-6W	D-14	22W-23146-L0	C-13
1LR-W0046-00	D- 4	39K-12481-00	B- 5	39K-14467-00	B- 6	174-17461-30	B-15	22W-22212-20-6W	C- 9	509-23151-L0	C-12
1LR-W0047-00	D- 4	39K-12482-00	B- 5	4V2-14468-02	B- 6	174-17461-40	B-15	22W-22212-30-6W	D-14		C-13
51L-W0048-00	D- 4	4V2-12494-00	B- 5	58T-14610-00	B-10	174-17461-50	B-15	3R4-22213-00	C- 9	22W-23153-L0	C-12
1LR-W0057-00	D- 4	353-13115-01	B-11	1LR-14613-00	B-10	22W-18101-00	C- 3	22W-22214-00	C- 9		C-13
1LR-11111-00	B- 2	1LR-13565-00	B- 6	39K-14718-00	B-10	22W-18110-00	C- 3	2X6-22216-00	C- 9	22W-23157-L0	C-12
1LR-11181-00	B- 2	22W-13581-00	B- 7	1LR-14753-00	B-10	22W-18140-00	C- 2	3R4-22221-01	C- 9		C-13
1LR-11311-00	B- 2	58T-13610-01	B- 6	565-14771-00	B-10	1W1-18177-00	C- 2	22W-22223-00	C- 9	509-23158-L0	C-12
4V0-11351-00	B- 2	58T-13613-00	B- 6	58T-1490J-00	B- 8	4V0-18511-00	C- 2	5X2-22228-00	C- 9		C-13
1LR-11400-00	B- 3	58T-13616-00	B- 6	39K-15111-00	B-11	39K-18512-00	C- 2	24X-22261-00	C-10	39K-23170-L0	C-12
39K-11412-00	B- 3	1LR-13621-00	B- 6	5X2-15113-01	B-11	4V0-18513-00	C- 2	24X-22262-00	C-10		C-12
39K-11422-00	B- 3	1LR-14101-00	B- 8	39K-15121-00	B-11	5X5-18531-01	C- 2	39K-22401-00	C- 9	39K-23173-00	C-12
39K-11611-00	B- 3	31J-14103-00	B- 8	4J2-15363-00	B-12	5X5-18535-01	C- 2	22W-22409-00	C- 9		C-12
	D-15	10W-14104-00	B- 9	3R4-15383-01	B-15	22W-18540-00	C- 2	39K-22472-00	C- 9	278-23181-50	C-12
39K-11611-10	B- 3	22W-14106-00	B- 8	58T-15411-00	B-12	1LR-21110-00-FH	C- 4	29L-22475-00	C- 9		C-13
	D-15	23L-14107-25	B- 8	1LR-15421-00	B-12	5X2-21511-10	C- 5	22W-22489-00	C- 9	58T-23184-L0	C-12
39K-11611-20	B- 3	2X6-14112-25	B- 8	22W-15451-00	B-12	22W-21523-00	C- 5	5X2-22493-00	C- 9		C-13
	D-15	2X6-14112-30	B- 8	5X2-15462-00	B-12	22W-21611-10	C- 5	3R4-22497-00	C- 9	39K-23340-L0	C-13
58T-11630-A0	D-15	2X6-14112-35	B- 8	4V0-15618-00	B-13	39K-21620-00	C- 5	1LR-23102-L0	C-12	3R4-23389-00	C-11
58T-11630-E0	D-15	3R1-14115-00	B- 8	22W-15620-00	B-13	4V0-21621-00	C- 5	58T-23103-L0	C-12	122-23411-00	C-11
58T-11630-F0	D-15	2A6-14126-00	B- 9	4V0-15621-00	B-13	39K-21711-11	C- 6	1LR-23108-00	C-11	122-23412-00	C-11
58T-11631-00-94	B- 3	248-14131-00	B- 9	4V0-15641-00	B-13	1LR-2172A-00	C- 6	58T-23110-L0	C-12	122-23416-00	C-11
	D-15	3R1-14141-50	B- 8	4V0-15651-00	B-13	39K-21721-10	C- 6		C-12	22W-23435-00-98	C-11
58T-11631-00-95	B- 3	3R1-14141-52	B- 8	22W-15660-00	B-13	1LR-2173F-00	C- 6	58T-23111-L0	C-12	1E6-23441-00	C-11
4V1-11633-00	B- 3	3R1-14141-54	B- 8	4V0-15664-00	B-13	1LR-2173L-00	C- 6		C-13	22W-23485-11	C-11
	D-15	260-14142-30	B- 8	1LR-16111-00	B-14	1LR-2174F-00	C- 4	22N-23118-L0	D-14	1LR-24110-00	C-14
	D-15	260-14142-35	B- 8	1LR-16150-00	B-14	1LR-2174G-00	B- 6	58T-23118-L0	C-12	5X7-2412F-00	C-15
	D-15	260-14142-40	B- 8	4V0-16154-00	B-14	1LR-2174L-00	C- 6		C-13	1LR-24157-00	C-14
5X2-11634-00	B- 3	137-14143-52	B- 8	21V-16321-00	B-14	1LR-21741-00	C- 6	122-23119-01	C-12	22W-24158-00	C-14
	D-15	137-14143-54	B- 8	257-16324-00	B-14	1LR-21785-00	C-11		C-13	59V-24173-00	C-14
	D-15	137-14143-56-A0	B- 8	1LR-16351-00	B-14	22W-21791-00	C- 6	22W-2312K-00	C-12	22W-24181-00	C- 6
	D-15	137-14143-58	B- 8	137-16356-00	B-14	1LR-22110-00	C- 7		C-12	22W-24183-00	C-15
58T-11635-00	B- 3	132-14146-00	B- 9	2X3-16357-00	B-14	22W-22124-00	C- 7	22W-23125-L0	C-12	1LR-24254-00	C-15
	D-15	39K-14153-00	B- 8	1LR-16371-00	B-14	401-22127-00	C- 7		C-13	1LR-24311-00	C-15
58T-11636-00	B- 3	2A6-14158-00	B- 9	58T-16382-00	B-14	401-22128-01	C- 7	1LR-23126-L0	C-12	1LR-24500-00	C-14
	D-15	3X3-14169-00	B- 8	4V0-17121-00	B-15	22W-22129-00	C- 8	122-23129-00	C-12	4X8-24512-00	C-14
39K-11650-00	D-15	4U5-14171-00	B- 9	39K-17131-00	B-15		C- 9		C-13	4X8-24534-00	C-14
1LR-11651-00	B- 3	304-14184-00	B- 8	39K-17151-01	B-15	5X6-22129-00	C- 7	39K-23136-L0	C-12	5X7-24611-00	C-14
39K-11651-00	D-15	314-14185-00	B- 8	39K-17161-01	B-15	4V1-22141-00	C- 7	39K-23141-00	C-12	5X7-24612-00	C-14
4V0-11681-00	B- 3	127-14186-00	B- 8	4V0-17221-00	B-15	1LR-22151-00	C- 7		C-13	1LR-24731-00	D- 2
	D-15	183-14196-00	B- 8	39K-17221-00	B-15	39K-2217A-00	C- 7	39K-23141-20	D-14	22W-24741-00	D- 2
39K-12422-00	B- 4	39K-14401-02	B- 6	4V0-17231-00	B-15	22W-2217F-00	C- 8	583-23142-00	C-12	1LR-24770-00	D- 2
5X2-12428-00	B- 4	1LR-14402-00	B- 6	39K-17241-00	B-15	30X-22178-00	C- 4		C-13	1LR-25104-00	D- 3
39K-12446-00	B- 5	5X5-14411-00	B- 6	39K-17251-01	B-15	5X1-2218A-00	C- 7	22W-23144-L0	C-12	1LR-25111-00-98	D- 3

NUMERICAL INDEX

PART NO.	GRID NO.	PART NO.	GRID NO.	PART NO.	GRID NO.	PART NO.	GRID NO.	PART NO.	GRID NO.	PART NO.	GRID NO.
39K-25304-00	O- 5	38V-82911-00	D-12	90185-10110	C- 7	90280-03017	B- 3	90501-10312	D-12	92902-04100	D-11
39K-25311-00-98	D- 5	38V-82913-00	D-12		C- 8	90282-05001	B-14	90501-12081	B-13		D-11
39K-25321-00-98	D- 5	23X-83912-00	D-12		C- 8	90338-07011	B-11	90501-20400	B-14	92902-12600	D- 9
3R0-25351-00	D- 5	55Y-83922-00	D-12		C- 9	90340-12095	B-11	90504-03033	B- 6	92906-05100	D-12
3R0-25355-11	D- 5	437-83936-00	B- 5		C- 9	90380-12094	C- 7	90506-14081	D- 5	92906-06600	B-12
1LR-25381-00	D- 5		C- 5	90185-12046	D- 3	90380-16109	C- 8	90506-28100	D- 9		D- 8
1LR-25388-00	D- 6		O-12	90185-12093	O- 5	90381-08002	B- 4	90507-20030	B-10	92990-03100	B- 6
5X2-25394-00	D- 5	437-83936-10	D-12	90185-12119	C- 7	90383-16023	C- 8	90508-18463	B-14	92990-06100	B- 5
39K-25444-00	D- 5	22W-83976-00	D-12	90201-06067	C- 7		C- 8	90508-20023	D- 9		B- 7
39K-25446-00	D- 5	1LR-85510-20	D-11	90201-06072	C-14	90384-18190	C- 7		D-10		B-10
39K-25448-00	D- 5	1LR-85540-20	D-11		C-14	90385-17042	C- 7	90508-26462	C- 2		C- 5
39K-25450-00	D- 5	58T-85541-20	O-11	90201-061H3	B- 5	90387-07392	B- 5	90508-26464	B-13		C- 6
1LR-25810-00	O- 4	2A7-85546-00	D-11	90201-065F3	C- 5	90387-07598	C-14	90508-32468	D- 9		C- 6
1LR-25831-00	D- 4	39K-85550-20	D-11	90201-06571	C- 6		C-14	90508-32642	C- 3		C-14
34X-25845-00	D- 4	58T-85580-20	D-11		C- 6	90387-105G9	C- 8	90560-12256	D- 5		C-14
56A-25852-00	D- 8	90101-06278	D- 5	90201-067A0	C- 4	90387-106G0	C- 8	90560-12257	D- 3		C-14
56A-25854-00	D- 8	90101-08475	D- 6	90201-08085	B- 4		C- 9	91311-06016	C-11		C-14
56A-25867-00	D- 8	90105-14137	C-11	90201-081A6	D- 5	90387-126F8	D- 3	91401-20015	D- 9		C-15
56A-25870-00	D- 8	90109-06577	D-12	90201-082A9	D-12	90387-127J7	C- 7	91401-25015	O- 9		O-13
1LR-25872-00	D- 8	90109-06797	D-12	90201-08649	B- 2	90387-127J8	C- 7		O- 9	92990-08100	C-13
5R2-25917-00	O- 4	90109-08666	O- 9	90201-08730	C- 5	90387-127J9	D- 6	92501-06012	B-11	92990-10600	C- 8
56A-25919-00	O- 4	90109-08706	O- 5	90201-100E9	C- 7	90387-202F0	B-14		C-15		C- 8
56A-25919-10	D- 4	90109-100E4	C- 7	90201-10118	O- 8	90387-22647	O- 7	92501-06014	B- 6		C- 9
56A-25926-00	D- 4	90109-10688	C- 8	90201-10144	D-10	90401-10034	O- 8		C- 6		C- 9
56A-25937-00	O- 4	90109-10689	C- 8	90201-102A2	O- 9	90430-06016	B-12		C- 6	93102-20143	B-15
22W-26111-00	O- 7		C- 9	90201-10591	D-11	90430-06166	B- 4		O-11	93102-20231	B- 3
4V4-26241-01	D- 7	90109-10729	C- 9	90201-10614	B- 4	90430-12038	B-11	92501-06020	O-13	93103-10147	B- 4
29U-26242-00	O- 7	90116-08402	B- 2	90201-120A5	C- 7	90445-08376	B-11	92501-06035	B-11	93103-28126	B- 3
22W-26243-00	O- 7	90119-06063	C- 5	90201-12163	B-13	90445-09304	C-14	92501-06045	B-11	93106-18013	O- 3
5X2-2628H-01	D- 7	90119-06085	B- 7	90201-12174	D- 3	90445-164E1	B- 7	92502-06016	C- 5	93106-20002	O- 5
5X2-26281-00	D- 7	90123-08013	O- 7	90201-124G9	C- 7	90460-22252	B- 5	92506-06008	B-12	93109-12012	C- 3
322-26282-00	O- 7	90149-06011	C-14	90201-12631	B-13	90460-27281	B- 5	92506-06016	B- 5	93109-14021	B-14
22W-26311-00	D- 7	90149-06153	O-12	90201-14411	B-14	90460-43053	B- 6	92506-06020	B- 4	93109-15001	B-13
39K-26335-00	O- 7	90159-05011	B-14	90201-154A1	B-13	90460-51059	B- 6	92506-06025	B-12	93109-16035	C- 8
382-26372-01	D- 7	90159-05101	C- 6	90201-191J4	C- 7	90460-58015	B- 6	92506-06030	B-12	93109-17048	C- 7
56A-26372-00	D- 8	90159-06013	C- 6	90202-06010	B-10	90464-20031	D-12	92506-06040	B-12	93210-14104	B-12
1LR-27211-00	D- 9	90159-06033	B- 7		C-14	90465-14242	C-11	92506-06060	B- 4	93210-16275	B- 5
39K-27231-00	O- 9	90159-06060	C-11	90206-12082	C- 9	90467-08004	B- 5	92701-06012	B-15	93210-18288	B- 8
22W-27311-00-R4	O- 9	90170-06010	O-12	90208-12015	B-14	90467-10008	C-15		O- 4	93306-00105	O- 3
22W-27321-00	O- 9	90170-20213	C- 9		B-14	90467-16063	B- 7	92901-06200	O- 9		D- 5
22W-27411-00-90	D- 9	90175-06016	O- 9	90209-06187	C- 5	90468-26046	B-13	92901-06600	B- 6	93306-00108	D- 5
22W-27421-00-90	O- 9	90179-08148	D- 7	90209-18112	B- 3	90480-12053	C- 6		B- 6	93306-20333	B-15
5X2-27422-01-33	D- 9	90179-12244	B-14		D-15	90480-13197	B- 7		B-10	93306-20401	B-15
1W1-28135-10	C- 4	90179-12335	B-14	90240-06040	D- 9	90480-15064	B- 5		C-11	93306-20438	B- 3
39K-82310-40	D-13	90179-25033	C-11	90240-08097	O- 9	90480-17359	C-10		D-11	93306-30101	O- 5
1M1-82370-21	D-13	90185-08113	C- 4		D- 9	90480-18290	C-14	92901-06700	C- 4	93310-312M5	B- 3
5X1-82519-00	D-12		C- 5	90249-12008	O- 9		C-14	92902-04100	B- 8		O-15
688-82535-00	D- 7		C- 7	90250-06013	C- 2	90501-10245	D- 9		O-11	93310-418M6	B- 3



NUMERICAL INDEX

PART NO.	GRID NO.	PART NO.	GRID NO.	PART NO.	GRID NO.	PART NO.	GRID NO.	PART NO.	GRID NO.
93310-418M6	D-15	95811-08135	C- 4						
93315-21429	B-14	95821-08030	C-11						
93315-31502	B-15	95821-08045	C- 7						
93317-11245	B-15	95821-10016	D- 9						
93317-21746	C- 7	95826-06020	B- 4						
93332-00059	C-11	97301-06012	B- 6						
93410-20038	B-15		C-14						
93430-08007	B-13		C-14						
93440-15012	B-15		D- 9						
93440-16089	B-15	97301-06016	B-10						
93440-42101	C- 9		C- 4						
93503-16010	B-14	97301-06025	B- 6						
	C-11	97301-06030	B- 5						
93507-32009	B-13	97311-10022	D-10						
93603-22028	B- 4	97321-06020	C- 3						
93604-10011	B- 4	97321-06030	C-14						
93604-26132	C- 9		C-14						
93608-30128	C- 3	97321-08040	C-13						
94107-177H8	D- 3	97326-06025	D- 8						
94108-17365	D- 3	97702-40116	B- 6						
94111-14364	D- 5	97801-03008	C-14						
94208-17238	D- 3	98501-03008	B- 6						
94211-14237	D- 5	98501-04005	C- 9						
94230-17214	D- 3	98501-04014	D-11						
94320-14096	D- 5	98506-04008	D-11						
94327-17079	D- 3	98506-05016	D- 7						
94327-17103	D- 3	98506-05018	D-12						
94414-17428	D- 3	98511-04016	B- 8						
94416-14375	D- 5	98511-04025	D-11						
94580-24112	D- 6	98706-04012	D- 7						
94680-24001	D- 6		D- 8						
95021-08012	C- 4	98903-06018	C-14						
95026-06025	C- 7	98906-06008	B-10						
95301-06600	D- 5	99001-07600	B- 4						
95301-06700	D- 9	99001-10600	C- 3						
95301-08700	D- 6	99002-09600	D- 9						
	D- 9	99009-12400	B-13						
95311-08600	B- 2	99009-18400	B-15						
95311-10600	D-11	99510-10114	B- 2						
95606-06100	D-12	99530-10014	B-12						
	D-12	99530-12016	B-11						
95611-08100	D- 5								
95702-10500	B-13								
95801-08020	C- 5								
95801-08025	C- 5								
95801-08035	C-11								
95811-08035	D- 4								
95811-08125	C- 4								

[www.legends-yamaha-enduros.com](http://www.legends-yamaha-enduros.com)