

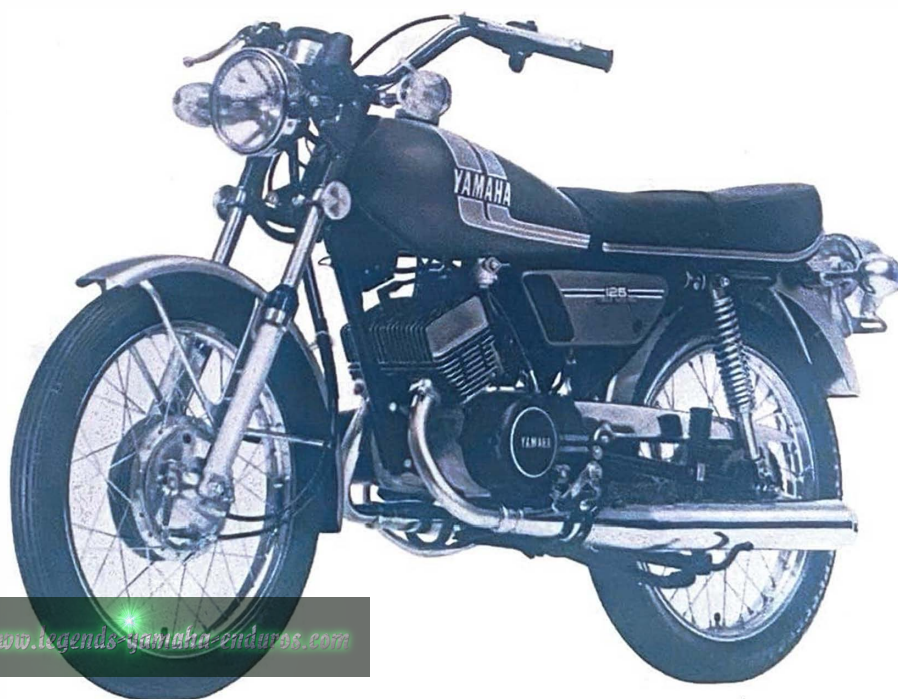

RD125B ASSEMBLY MANUAL



90894-07409

FOREWORD

This Assembly Manual contains the information required for the unpacking and assembly of Yamaha motorcycles so that the Yamaha serviceman can assemble the machine in the correct manner. To perform machine assembly, a basic knowledge of service and Yamaha machines is required. Therefore, all Yamaha dealers are urged to make a full study on the service of Yamaha motorcycles using the relevant service manuals.

NOTICE

The service specifications given in this Assembly Manual are based on the model as manufactured when this manual was published. Since this model may require improvements, the service standards may be subject to change in the future. If any change is introduced into the specifications or service procedures, Yamaha dealers will be notified through technical service information to be published by Yamaha. The assembly procedure is described in the order that the mechanic should follow, and the correct service tools should be used in the correct manner. Failure to do this may result in poor performance and danger to the rider.

**YAMAHA RD125B
ASSEMBLY MANUAL
1st EDITION, AUGUST, 1974
OVERSEAS SERVICE DEPARTMENT
YAMAHA MOTOR CO., LTD.
IWATA, JAPAN
LIT-11664-00-09**

CONTENTS

PREPARATION	1
Tools for unpacking	1
Tools for assembling	1
Supplies	2
Workshop	2
UNPACKING	2
Notes on transportation	2
Procedure for unpacking	2
PARTS CHECK LIST	3
INSTALLATION GUIDE	5
SET-UP PROCEDURES	6
INSPECTIONS AND ADJUSTMENTS	18
Inspections	18
Adjustments	19
Service specifications	22
MISCELLANEOUS	23

PREPARATION

To assemble the machine correctly, the following service tools, supplies and working space are required:

Tools for unpacking

1. Nail puller
2. Scissors
3. Wire cutter

Tools for assembling

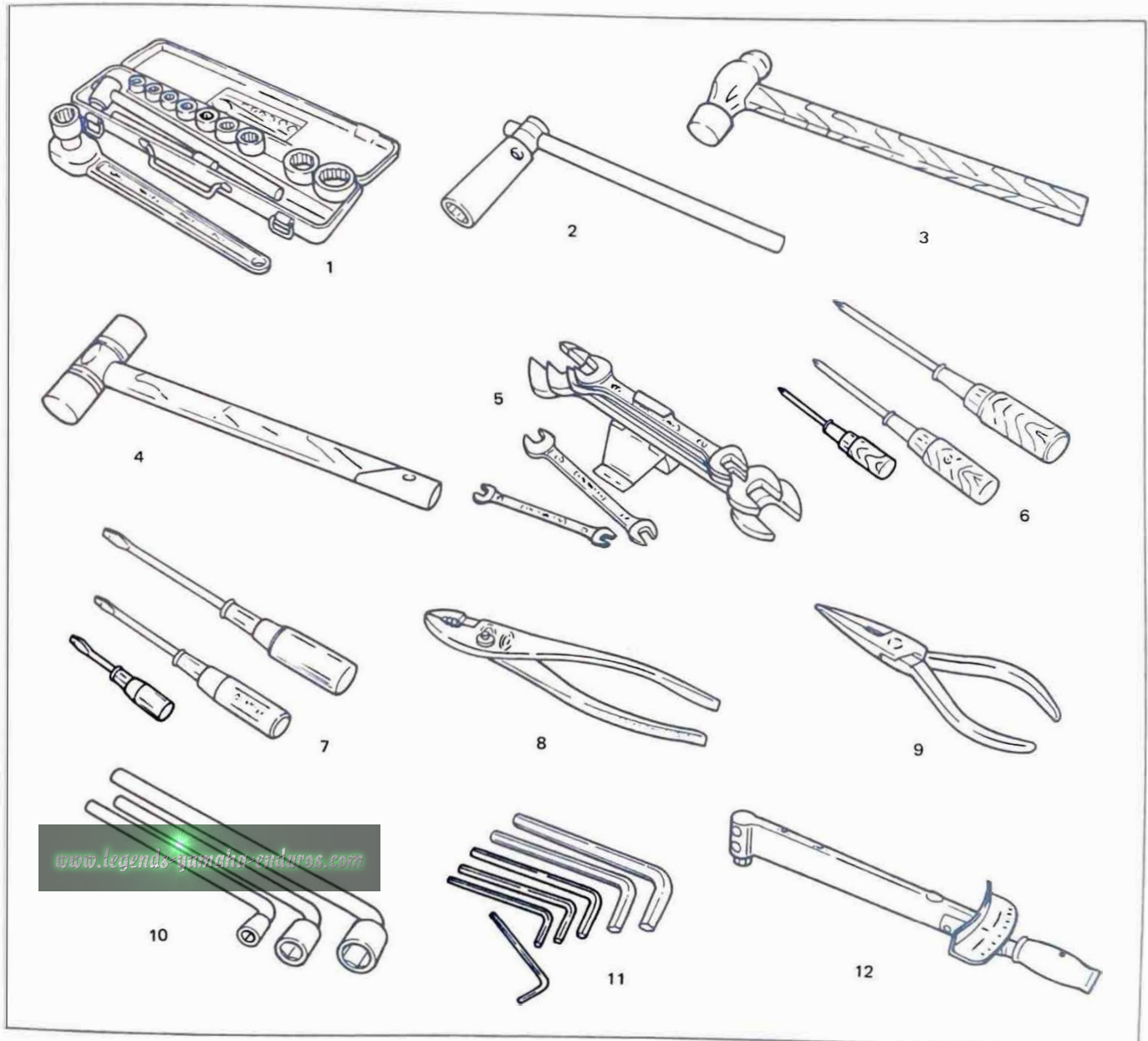

1. Socket wrench set
2. Spark plug wrench
3. Steel hammer
4. Soft-faced hammer
5. Wrench set
6. Phillips head screwdrivers (Large, medium and small)

7. Slotted head screwdrivers (Large, medium and small)
8. Pliers
9. Long nose pliers
10. L-handle socket wrench
11. Allen wrench set
12. Torque wrench

Fig. 1

Supplies

1. Oils
2. Greaser
3. Shop rags
4. Electrical contact cleaner

Workshop

The workshop where the machine is assembled should be clean and large. The floor should be level.

UNPACKING

Note on transportation

Use care not to butt the machine, packed in the crate, against a hard object or give it a heavy shock during transportation or in the service shop.



Fig. 2

Procedure for unpacking

To remove the machine and parts packed in the cardboard crate, cut the vinyl bands around the box using a cutter or scissors. Next, remove the exterior carton by lifting it straight up. (Figs. 2 ~ 4)

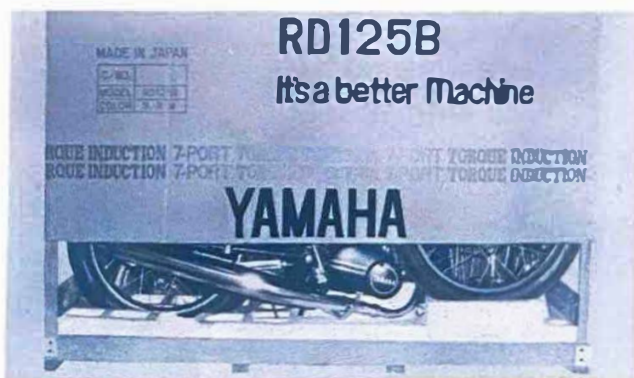

Fig. 3

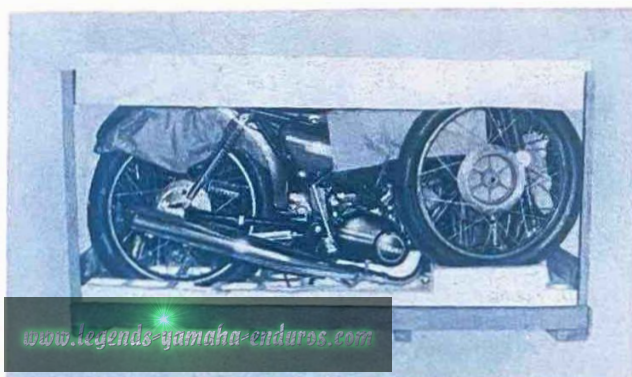

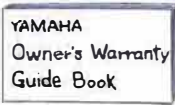
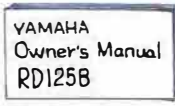

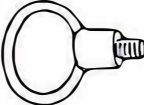







Fig. 4

PARTS CHECK LIST

The following parts are contained in the foam tray and the vinyl bag in the package. Check the quantity of parts against the list. Also check for damage. (Fig. 5)

1. Details of parts in Vinyl Bag.

(per unit)

No.	Illustration	Parts Name	Q'ty	Remark
a		Owner's Warranty Guide Book	1	
b		Owner's Manual	1	
c		Clevis pin	2	for seat
d		Wire holder	1	Brake & speedometer wire holder
e		Nut (6 mm.)	1	
f		Spring washer (6 mm.)	1	
g		Cotter pin	1	for front axle
h		Flasher collar	2	for rear flasher light
i		Handle holder	1	for handle bar holder
j		Hexagon bolts (8 mm.)	4	
k		Spring washer (8 mm.)	4	

PARTS CHECK LIST

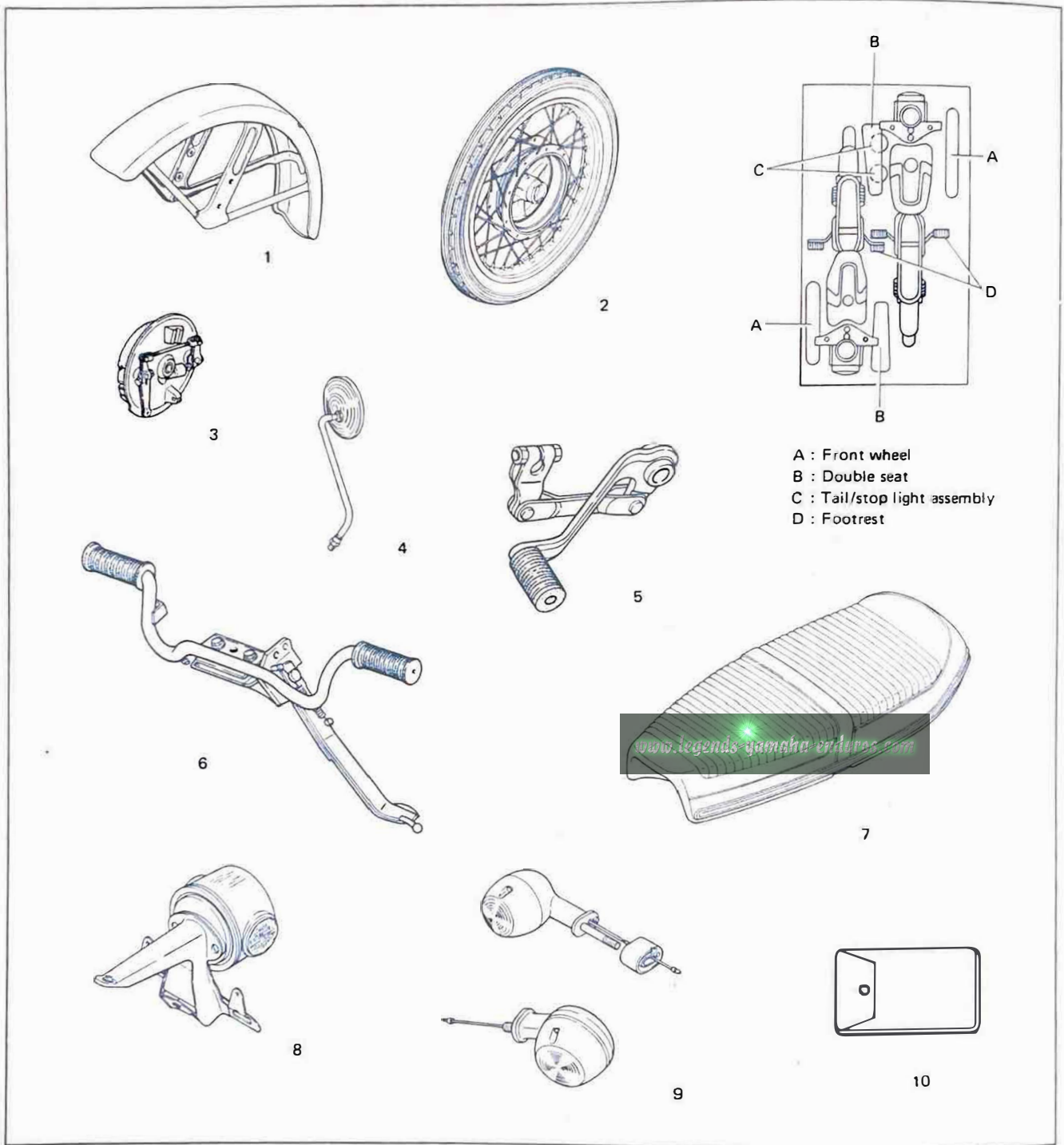

Fig. 5

No.	Parts Name	Q'ty
1	Front fender	1
2	Front wheel	1
3	Brake shoe plate assembly	1
4	Rear view mirror	1
5	Change pedal	1

No.	Parts Name	Q'ty
6	Footrest and side stand assembly	1
7	Seat	1
8	Taillight assembly	1
9	Flasher light (Front & Rear)	2 set
10	Service tools	1

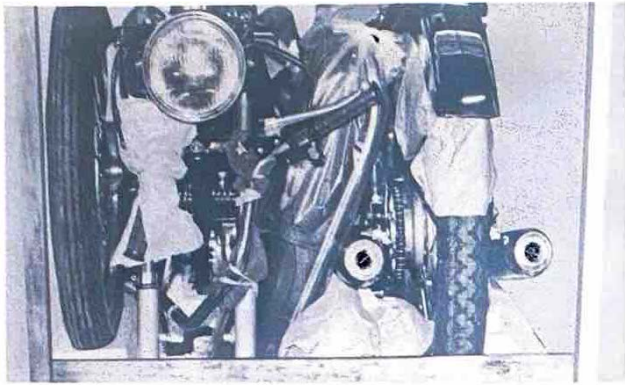

Fig. 7

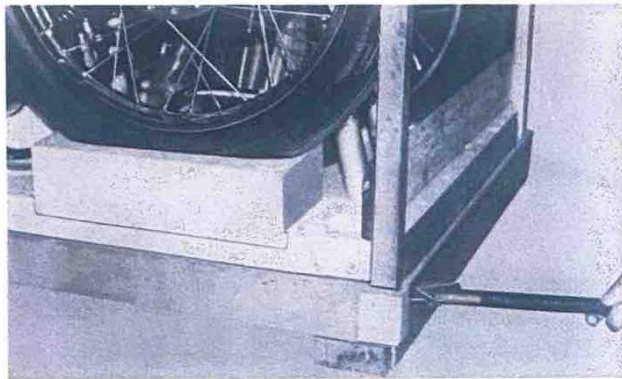

Fig. 8

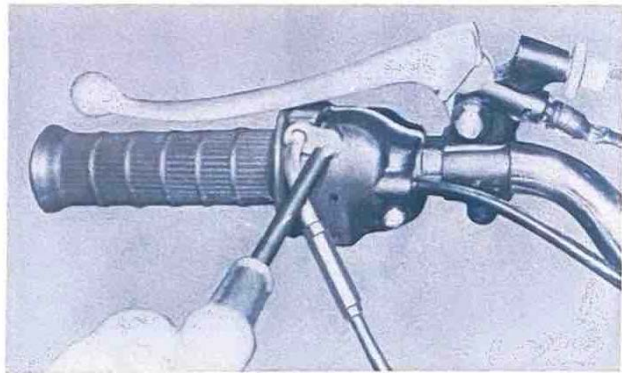

Fig. 9



Fig. 10

SET-UP PROCEDURES

Remove the seats, front wheels and tail/top lights. (Fig. 7)

Remove the nails from each corner of the crate, and remove the struts. (Fig. 8)

Set up the machine as follows.

Note that the cords on the right and left handle switches are not disconnected inside the light body, and that throttle wire is not removed from the throttle grip.

1. Remove the handlebar, throttle grip and brake lever holder from front forks. Then slip the brake lever holder and throttle grip over the handlebar. (Fig. 9)

Note:

Before installing the throttle grip, grease the right end of the handlebar.

2. Install the handlebar using the holder and four hexagon bolts and spring washers. (Fig. 10)

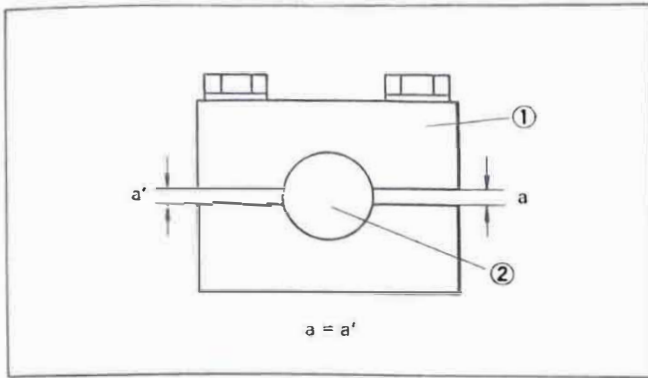

Fig. 11



Fig. 12

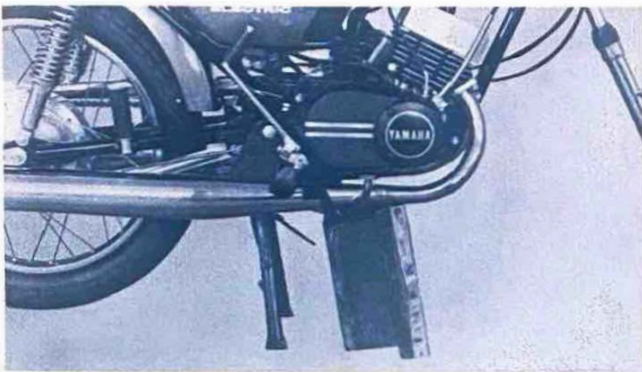

Fig. 13

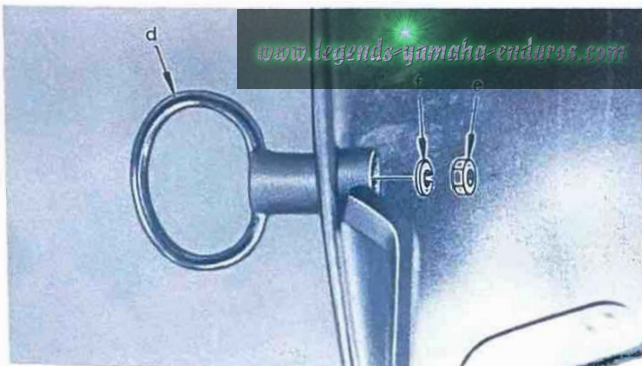

Fig. 14

Caution:

Tighten bolts in stages and maintain an equal gap on each side of holder. (Fig. 11)

1. Holder
2. Handlebar

3. Lift up the machine, and remove the rear wheel section from the foam base. Then take out the machine.
4. Remove the front fender held between the rear tire and the rear fender. (Fig. 12)

5. To install the front fender and front wheel, place a proper-sized wooden box or a wooden block under the engine to keep the front of the machine raised off the floor. Take care so that the machine does not fall over. (Fig. 13)

6. Using the spring washer and nut contained in the vinyl bag install the wire holder on the front fender. (Fig. 14)

Spring washer: 6 mm. x 1

Nut: 6 mm. x 1

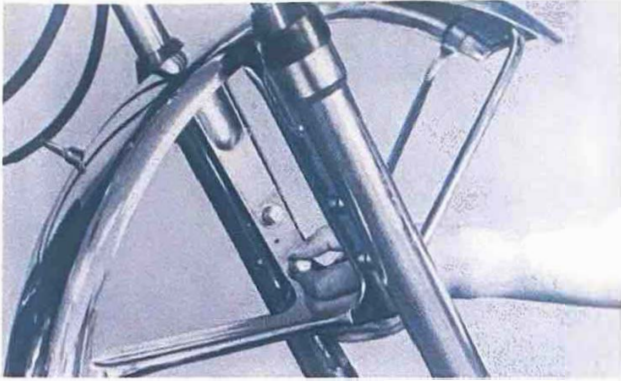

Fig. 15

7. Insert the front fender between the front forks and secure the front fender using 8 mm bolts and spring washers. (Fig. 15)
Tightening torque: 0.8 ~ 1.3 m-kgs.

Note:

Bolts and spring washers are fitted to the outer tube of the front fork.

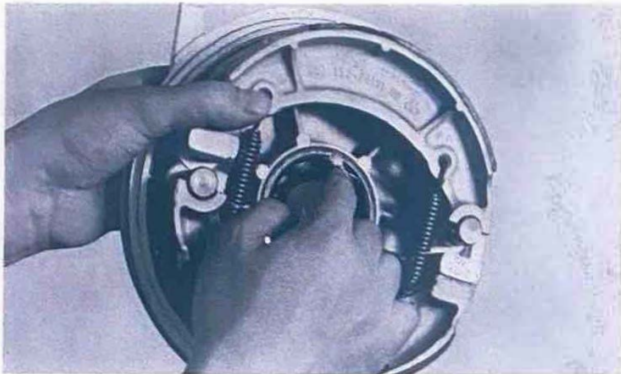

Fig. 16

8. Apply a light coat of grease to the speedometer drive gear and oil seal. (Fig. 16)

Caution:

Take care not to put grease on the brake linings or inner surface of the brake drum.

If you do so, clean using a rag dampened with solvent. Foreign material on braking surface can cause impaired braking action.

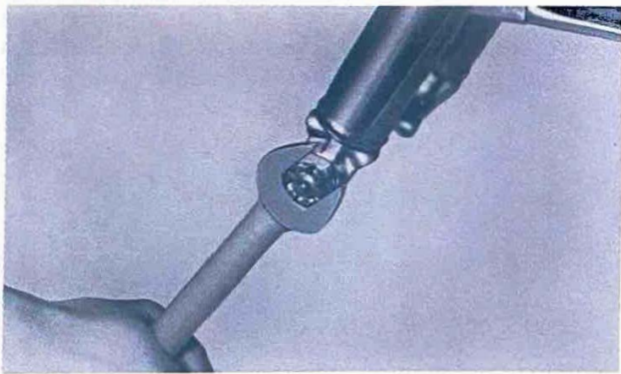

Fig. 17

9. Remove the front wheel axle nut and plain washer, and loosen the pinch bolt securing the axle. Then remove the wheel axle. (Fig. 17)

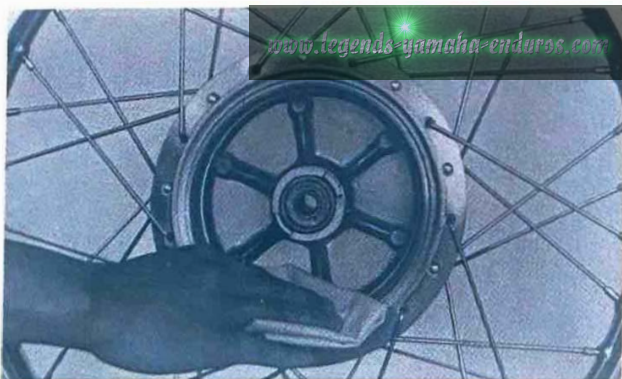

Fig. 18

10. Install the brake shoe plate assembly in the front wheel hub.

- (1) Clean the inner surface of the front wheel hub with a clean cloth. (Fig. 18)

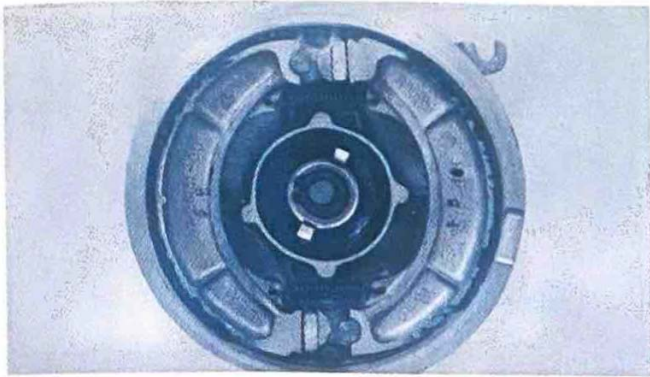

Fig. 19

- (2) Make sure the brake shoes and springs are correctly installed in the shoe plate assembly. If any one of them is out of place, correct per the figure. (Fig. 19)

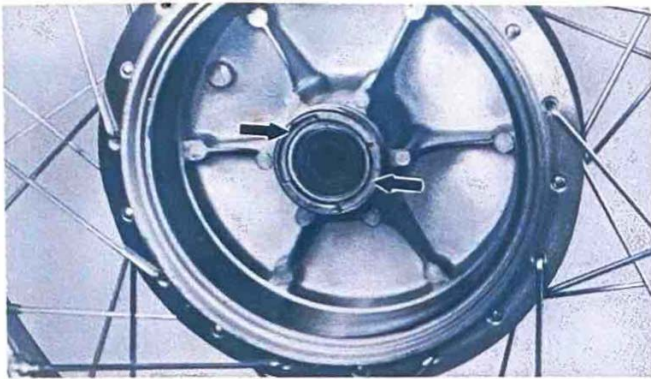

Fig. 20

- (3) Install the brake shoe plate assembly in the wheel hub.

Note:

Make sure the two lugs in the wheel hub align with the two slots in the speedometer clutch assembly. (Figs. 20, 21)

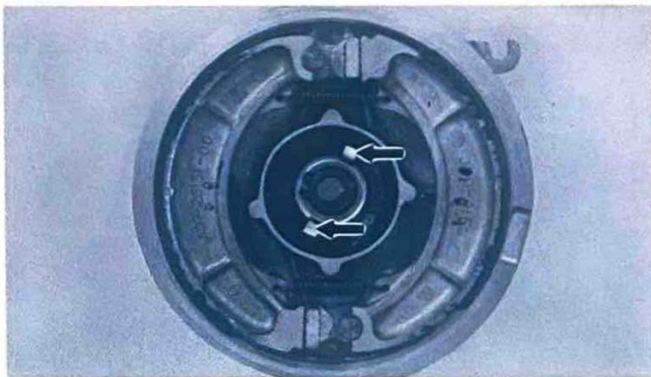

Fig. 21



Fig. 22

- (4) Apply a thin coat of lithium base grease to the oil seal in the wheel hub. (Fig. 22)

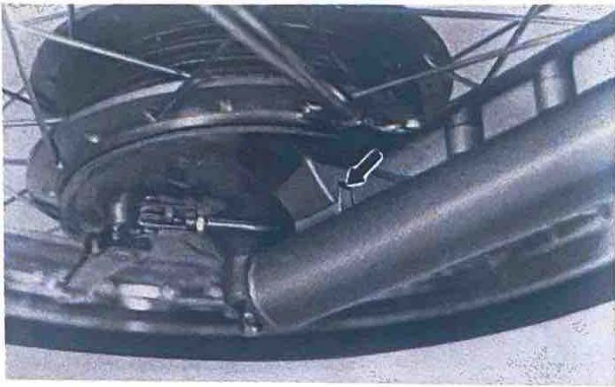

Fig. 23

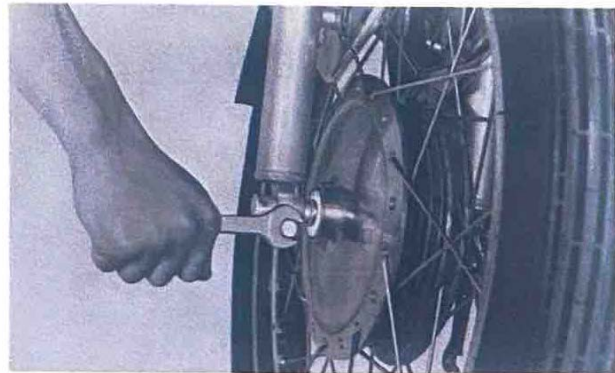

Fig. 24



Fig. 25



Fig. 26

11. Install the front wheel on the front forks.
 - (1) Insert the front wheel between the front fork legs so that the stopper (projection) on the front fork outer tube correctly engages the slot in the brake shoe plate. (Fig. 23)

- (2) Insert the axle, mount the plain washer on the axle, and install the axle nut.
- (3) Lightly tighten the axle pinch bolt so that the axle does not turn while the axle nut is tightened. (Fig. 24)
- (4) Torque the axle nut to specification.
Tightening torque:
6.6 ~ 10.5 m-kgs. (48 ~ 76 ft-lbs.)

- (5) Lock the nut with the cotter pin. The pin should be inserted downward, and the pin ends should be bent. (Fig. 25)
- (6) Torque the axle pinch bolt to specification.
Tightening torque:
1.6 ~ 2.6 m-kgs. (12 ~ 19 ft-lbs.)

12. Connect the speedometer cable to the front wheel hub gear unit. Insert the cable end into the gear unit and fit the circlip in the groove on the wheel hub side, and lock the cable. (The circlip is already attached to the cable.) (Fig. 26)
13. Install the rear view mirror on the clutch lever holder (lefthand side) and tighten the lock nut.



Fig. 27

14. Remove the Phillips head screw from the left side of the headlight body. Insert a slotted head screwdriver between the headlight body and the headlight rim, pry out the lens assembly. (Fig. 27)

Note:

During the operation, care should be taken not to scratch the headlight body and lens rim. Also take care so that the anchor screw is not lost.

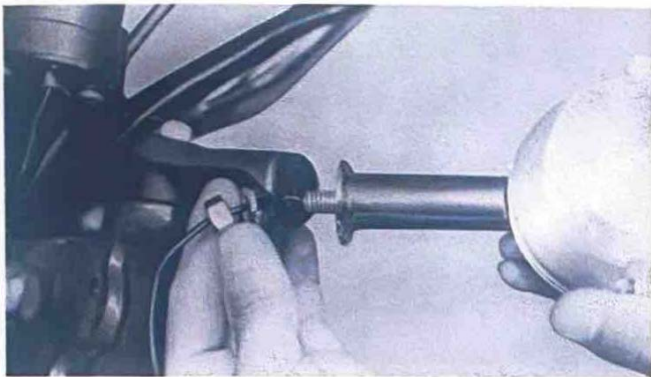

Fig. 28

15. Front flasher light installation
 - (1) Install the flasher light to the flasher light bracket with 8 mm nuts and spring washers. (Fig. 28)

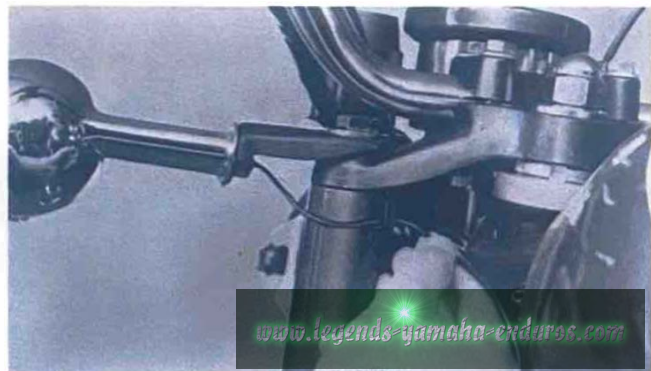
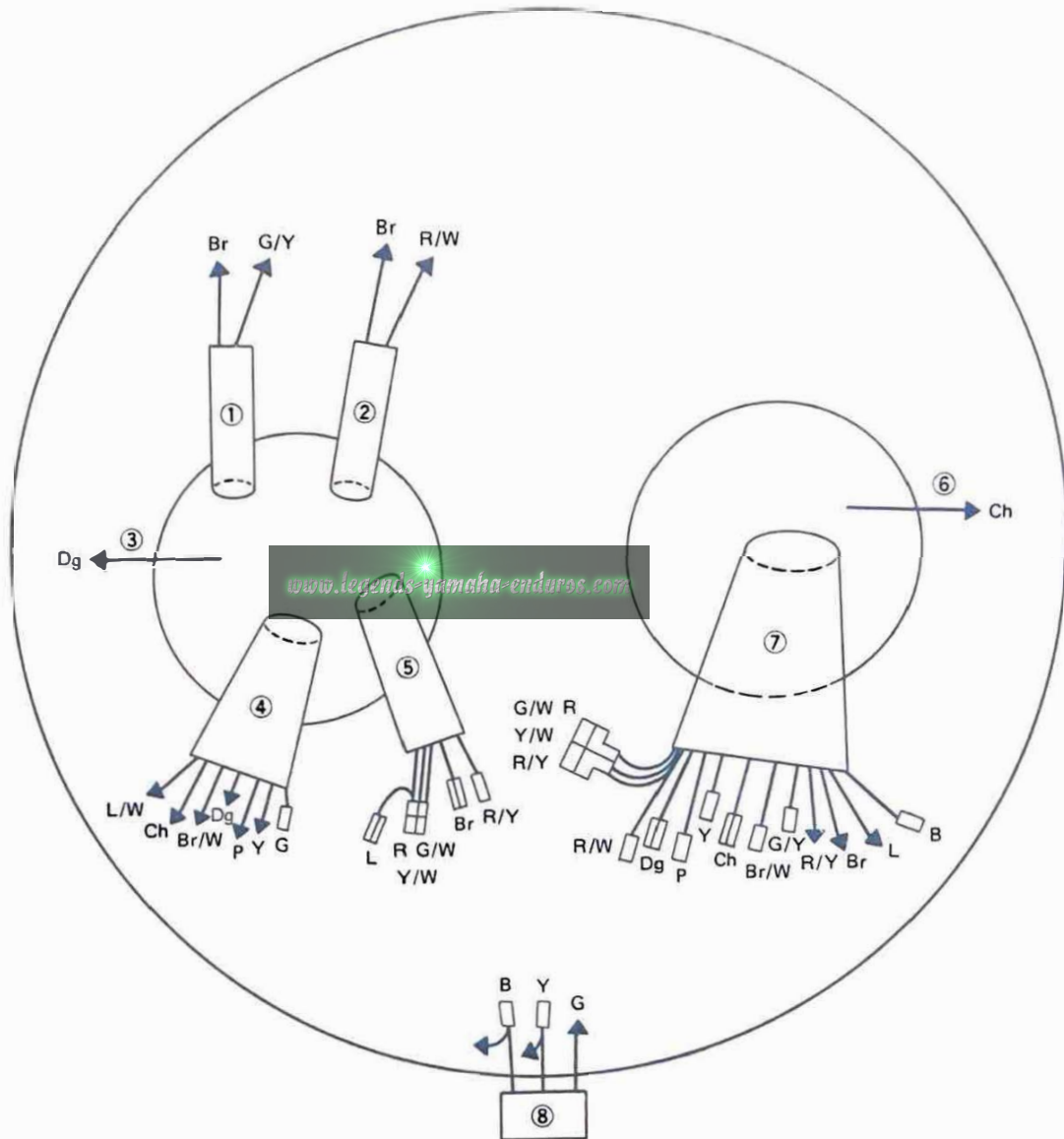

Fig. 29

- (2) Bring the flasher light lead wire into the headlight body through the clamp (behind the light stay); then connect it to the wire harness.

16. Connect all lead wires inside the headlight body. The wires of identical colors should be connected.



- | | |
|----------------------------|---------------------------------|
| 1. From front stop switch | 5. From main switch |
| 2. From engine stop switch | 6. Front flasher light (R) |
| 3. Front flasher light (L) | 7. From wire harness |
| 4. From handle switch | 8. From headlight lens assembly |

Fig. 30

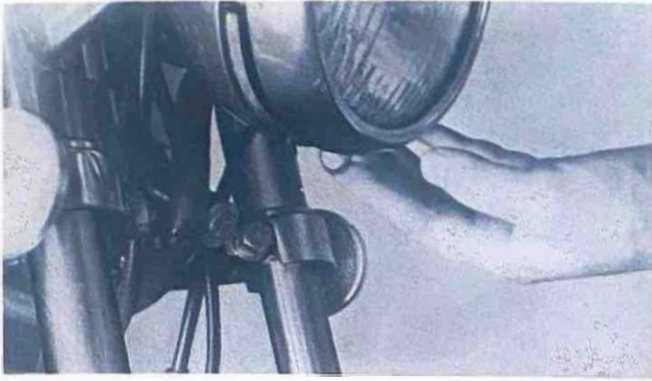

Fig. 31

17. When installing the headlight lens assembly, care should be used so that wires are not pinched. Secure the headlight assembly in place with the Phillips head screw. (Fig. 31)

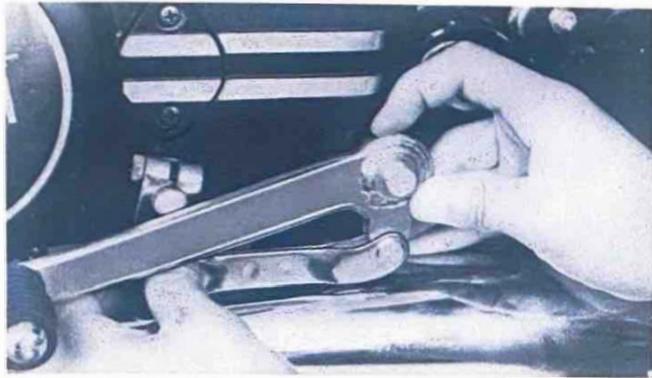

Fig. 32

18. Install the change arm to the change arm pivot shaft and change shaft link lever to the change shaft. Then install the washer and the circlip to the change arm pivot shaft, and tighten the pinch bolt. (Figs. 32 ~ 34)

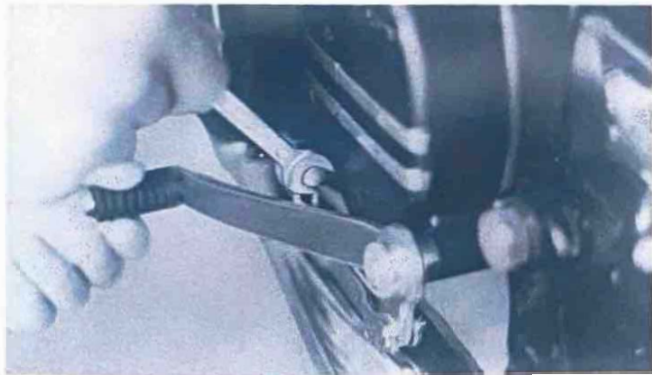

Fig. 33



Fig. 34

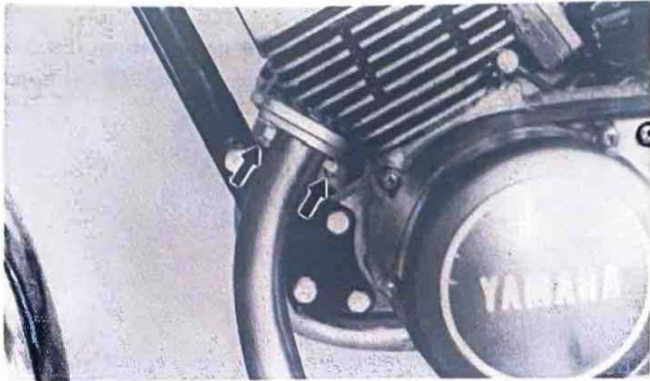

Fig. 35

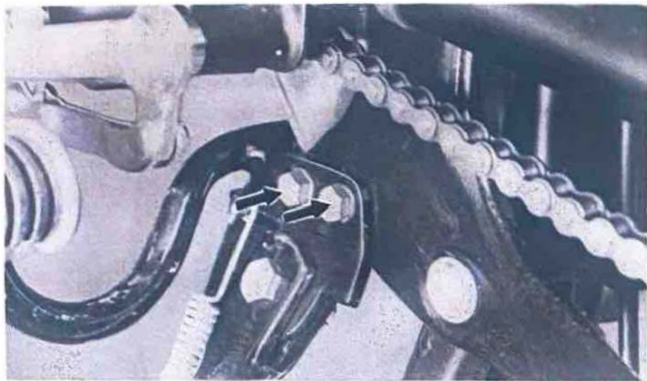

Fig. 36

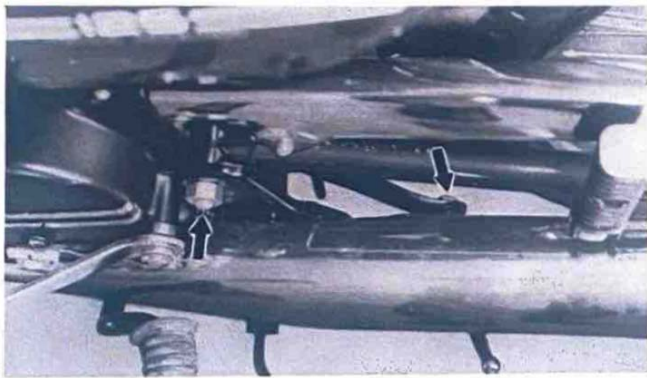

Fig. 37



Fig. 38

19. Installing the footrest

- (1) Remove all bolts and nuts securing the left side muffler to the frame, then remove the left side muffler. (Fig. 35)

- (2) Insert the footrest bracket into the frame bracket from under the frame. Then install the footrest with two 8 mm. bolts. (Fig. 36)

- (3) Install the left side muffler with nuts. (Fig. 37)

20. Taillight assembly installation

- (1) Connect the taillight lead wire to the wire harness, and lock it with the hook. (The wires of identical color should be connected.) (Fig. 38)



Fig. 39

- (2) Using the bolt, washer with rim, fender mounting collar, spring washer and nut secure the front part of the tail/stoplight bracket to the rear fender. (Fig. 39)

Note:

Bolt, washer, collar, spring washer and nut are fitted to the tail/stoplight bracket.

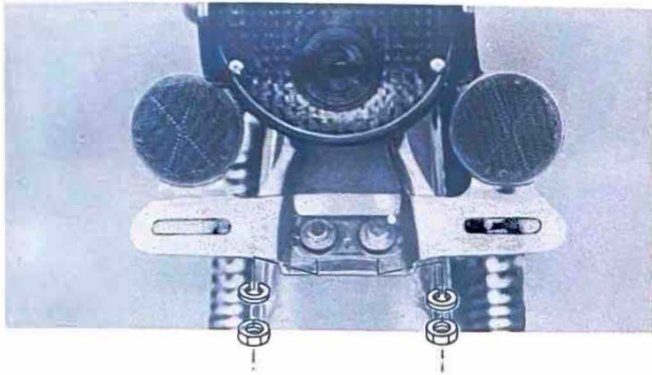

Fig. 40

- (3) Using the shouldered bolts, plain washers, spring washers and nuts secure the rear part of the tail/stoplight bracket to the fender. (Fig. 40)

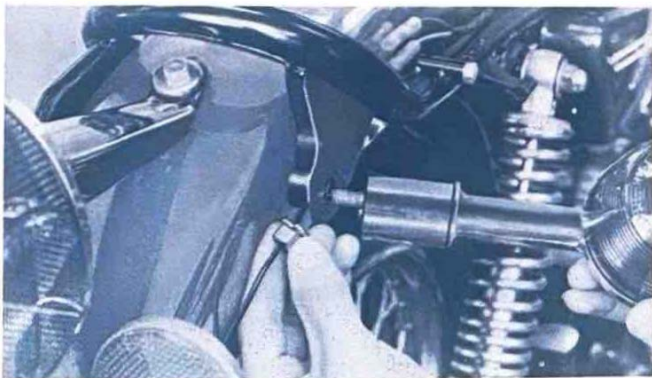

Fig. 41

21. Rear flasher light installation

- (1) Install both flasher light assembly and collar by aligning with the locating pin. (Fig. 41)



Fig. 42

- (2) Connect the flasher lead wires to the wire harness on the rear fender. (Fig. 42)

Right flasher light lead wire → Dark green

Left flasher light lead wire → Dark brown

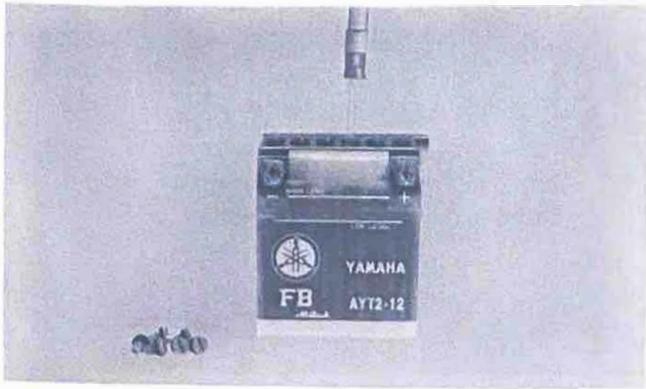

Fig. 43

22. Battery

- (1) When filled with diluted sulfuric acid (electrolyte), this battery can be put into use immediately. That is, it is a dry-charged battery. It is advisable, however, that the battery be charged as much as possible before using for the first time for maximum performance. This initial charge will prolong the life of the battery.

Charging current: 0.55 A.

Charging hours: 10 hrs.

- (2) Filling the battery with diluted sulfuric acid (Fig. 43)
 - a. Remove all filler caps from the battery, and remove the breather pipe cap at the same time.
 - b. Cool the diluted sulfuric acid down to below 30°C (86°F).
 - c. Pour diluted sulfuric acid into each cell little by little up to the upper level line, and leave it for a while. When the battery fluid permeates the plates and separators, the fluid level begins to lower. Add diluted sulfuric acid again.
 - d. Charge the battery as required, and measure the specific gravity of the fluid.
 - e. Install the filler caps, and thoroughly wipe off the fluid around the filler caps.



Fig. 44

- (3) Battery installation (Fig. 44)

- a. Make sure the main switch is turned off, and connect the positive and negative lead wire.

Note:

After connecting the positive lead wire be sure to place the rubber cover to prevent shorting.

- b. Install the battery in the battery box, and secure the battery with a band.
- c. Connect the lead wires to the wire harness.

Note:

The wires of identical color should be connected.

- d. The breather pipe should be connected as illustrated. (Fig. 45)

Note:

Route the breather pipe outlet down and away from any part of the machine.

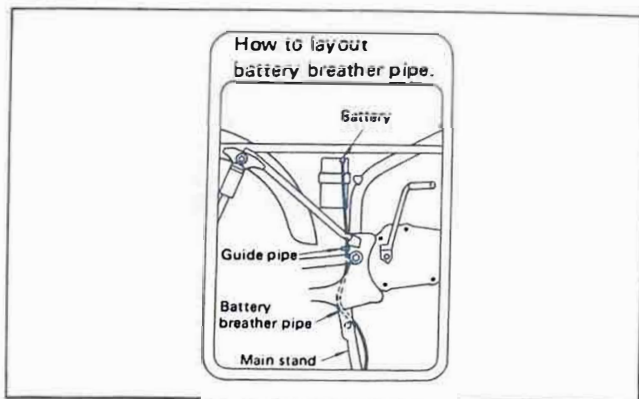

Fig. 45

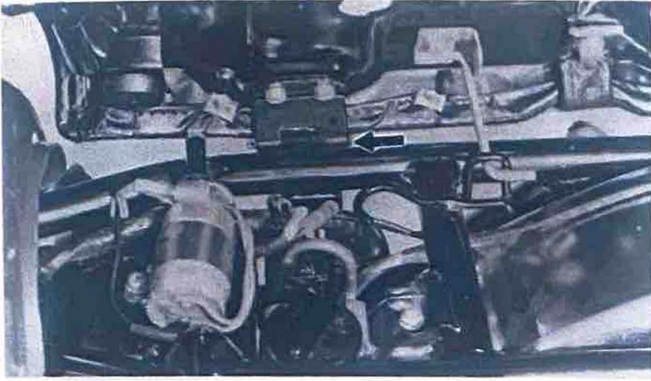

Fig. 46



Fig. 47

23. Seat installation

Remove the lock plate from the seat, and using the clevis pins, secure the seat to the frame. The clevis pins should be installed into the stay from the rear side, and its front end should be locked with lock plate. (Figs. 46, 47)

INSPECTIONS AND ADJUSTMENTS

Inspections

After all packed parts are installed, check to see that all these parts and other parts (mounted or installed at the Yamaha factory) are correctly mounted or installed, or tightened to specification. This check-up should be started with the front of the machine.

Item	
Front wheel spokes Tension
Front wheel rim Hopping, deflection
Front wheel tire Tire pressure
Front wheel axle nut Cotter pin, tightening torque
Front wheel axle pinch bolt Tightening torque
Front fork pinch bolts Tightening torque
Steering head lock nut Tightening torque
Handlebar holder Tightening torque
Clutch lever holder Tightening torque
Brake lever holder Tightening torque
Front flasher light Mounting, wiring
Throttle housing Position, operation, tightness
Engine mounting bolts Tightening torque
Carburetor joint(s) Tightness
Footrests Position, tightening torque
Change pedal Position, looseness, operation
Brake pedal Position, looseness, operation
Seat Mounting, clevis pin
Fuel tank Mounting
Fuel pipe Connection
Battery Mounting, fluid level, wiring
Rear fender Mounting
Taillight Mounting, wiring
Rear flasher light Mounting, wiring
Rear shock absorber Mounting, tightening torque
Rear swing arm pivot shaft Tightening torque
Rear axle nut Cotter pin, tightening torque
Chain puller Lock nut
Rear wheel Spoke tension
Rear wheel rim Hopping, deflection
Rear wheel tire Tire pressure
Transmission oil Oil level
Engine oil Oil level

Adjustments

Note:

This section deals with the main points only. For details, refer to the service manual for this model.

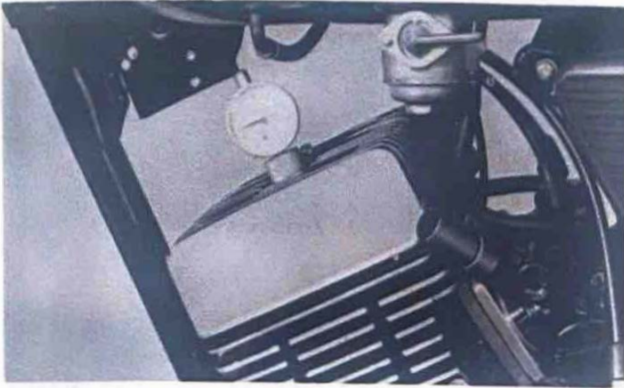

Fig. 48

1. Ignition timing – checking and adjustment (Fig. 48)

After starting the engine, check the ignition timing, and if necessary, adjust.

Ignition timing: $0.071 \begin{matrix} +0.008 \\ -0.02 \end{matrix}$ in. ($1.8 \begin{matrix} +0.2 \\ -0.5 \end{matrix}$ mm.)

Note:

For details, refer to the service manual for this model

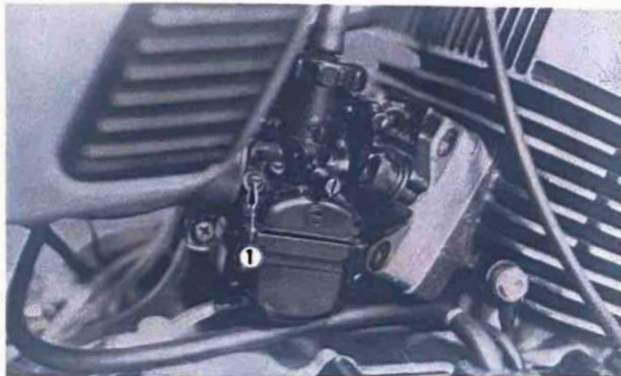

Fig. 49

2. Idling speed adjustment (Figs. 49, 50)

- (1) Before adjustment, fully warm up the engine.
- (2) Start the engine, and idle the engine a little faster by screwing in the throttle stop screws, both right and left.
- (3) Screw in and out slowly either of the right and left pilot screws, and stop turning when the engine idles faster.
Standard turns out: 1-1/2
- (4) By backing out both throttle stop screws evenly, reduce the idling speed to specification.
Standard Speed: 1,150 ~ 1,250 r.p.m.

1. Pilot air screw

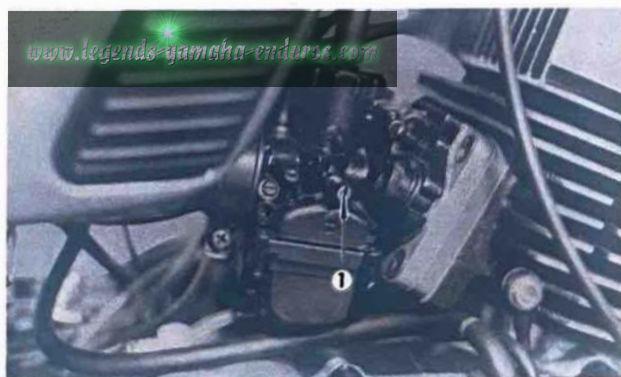

Fig. 50

1. Throttle stop screw

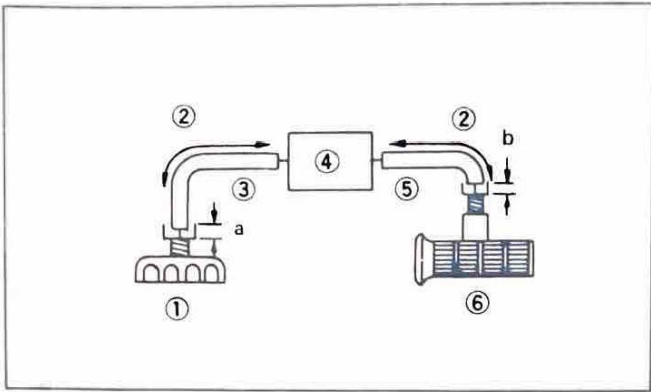

Fig. 51

3. Throttle wire adjustment (Fig. 51)

- (1) After adjusting the idling speed, adjust the play in throttle wire 2 (both right and left) to 0.04 in. (1.0 mm.)
- (2) Next, adjust the play of throttle wire to 0.02 ~ 0.04 in. (0.5 ~ 1.0 mm.) at the throttle cable end.

a. 0.04 in. (1 mm.)

b. 0.02 ~ 0.04 in. (0.5 ~ 1.0 mm.)

1. Carburetor case

4. Junction block

2. Slide

5. Cable 1

3. Cable 2

6. Throttle grip

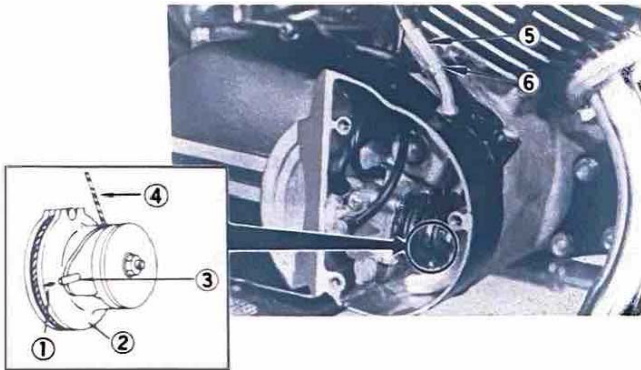

Fig. 52

4. Pump wire adjustment (Fig. 52)

- (1) Remove pump cover
- (2) Open throttle slightly to take up all play.
- (3) Loosen wire adjuster lock nut and turn adjuster in or out until the proper mark on the adjusting pulley is aligned with the guide pin.

1. Mark

4. Pump cable

2. Adjust pulley

5. Adjustor

3. Pin

6. Adjustor locknut

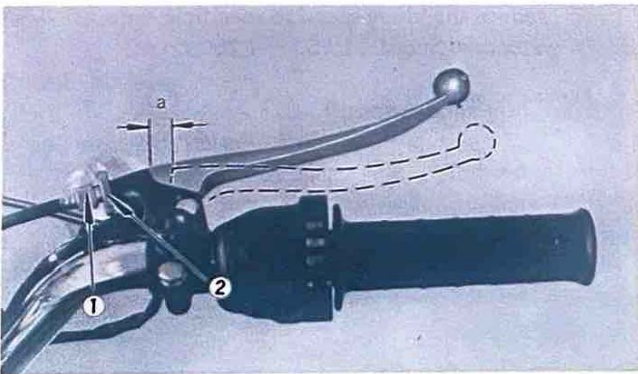

Fig. 53

5. Front brake wire adjustment (Fig. 53)

Loosen the brake wire adjuster lock nut, and adjust the play of the brake lever (at the position illustrated) to specification. After the adjustment, be sure to screw in the lock nut until tight.

Standard value: 0.2 ~ 0.3 in. (5 ~ 8 mm.)

a. 0.2 ~ 0.3 in. (5 ~ 8 mm.)

1. Adjustor

2. Adjustor locknut

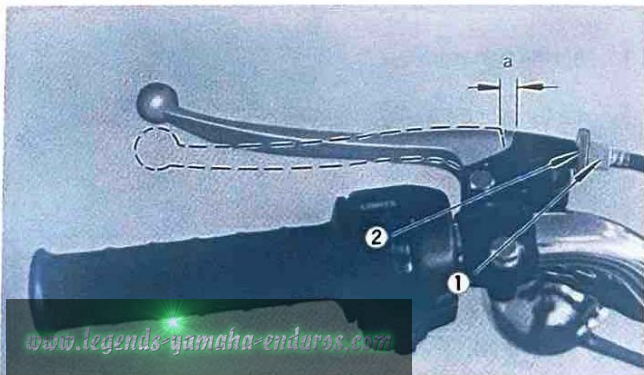

Fig. 54

6. Clutch wire adjustment (Fig. 54)

Loosen the clutch wire adjuster lock nut at the clutch lever, and adjust the clutch wire by turning the wire adjuster.

Turning the adjuster clockwise (the adjuster is tightened) increases clutch wire play, while turning counterclockwise decreases the play.

The play should be (1/16 ~ 1/8 in. (2 ~ 3 mm.)) at the position shown in the figure.

a. 1/16 ~ 1/8 in. (2 ~ 3 mm.)

1. Adjustor

2. Adjustor locknut

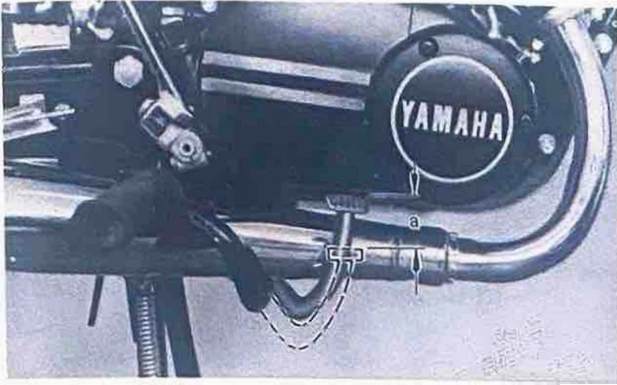

Fig. 55

7. Rear brake pedal adjustment (Fig. 55)

Rear brake pedal play can be adjusted by turning the adjusting nut on the rear end of the brake rod. Turning clockwise (tightening) decreases play. Turning counterclockwise (loosening) increases play. Standard value: 0.8 ~ 1.1 ins. (20 ~ 30 mm.) at the brake pedal

a. 0.8 ~ 1.1 ins. (20 ~ 30 mm.)



Fig. 56

1. Adjust nut

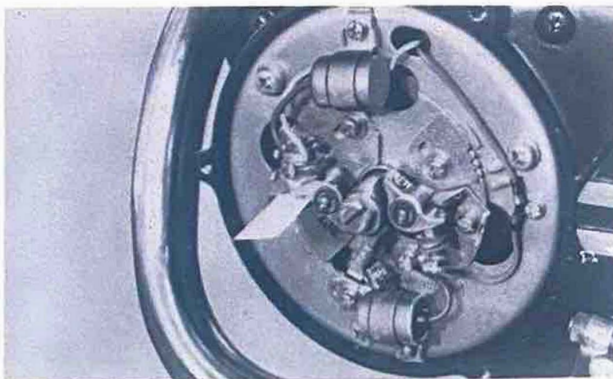

Fig. 57

8. If the engine is hard to start, check the following points.

(1) Carburetor

Remove the drain screw attached to the carburetor float bowl, and drain off the gasoline.

(2) Breaker points – checking and cleaning (Fig. 57)

The breaker point surfaces may be dirty. Clean with a clean name card (heavy paper) dampened with contact cleaner, and try to start the engine.

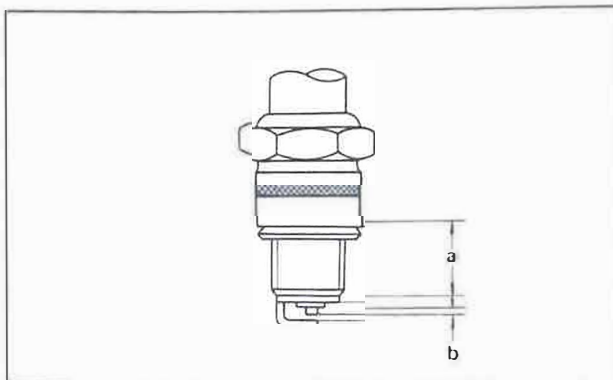

Fig. 58

(3) Spark plug – checking and adjustment (Fig. 58)

When the machine is stored or not used for a long period of time, the spark plug may get wet with oil. If so, hard starting will result. Remove the spark plug and clean as required.

a. Reach 1/2 in. (12.7 mm.)

b. Gap 0.024 ~ 0.028 in. (0.6 ~ 0.7 mm.)

Service specifications

Item	125B		
	Normal (New)	Minimum Allowable	Maximum Allowable
IGNITION			
Minimum Spark Length	—	0.24 in. (6 mm.)	—
Ignition Coil Primary Resistance	4.0Ω ± 10% at 20°C	—	—
Ignition Coil – Secondary Resistance	11kΩ ± 20% at 20°C	—	—
Ignition Coil – Condenser Capacity	0.15μF	—	—
Ignition Point Gap	0.014 in. (0.35 mm.)	0.012 in. (0.30 mm.)	0.016 in. (0.40 mm.)
Spark Plug Type/Manufacturer	B-8HS/NGK	—	—
Spark Plug Gap	—	0.024 in. (0.6 mm.)	0.028 in. (0.7 mm.)
Ignition Timing (B.T.D.C.)	0.071 in. (1.8 mm.)	0.051 in. (1.3 mm.)	0.078 in. (2.0 mm.)
CARBURETION			
Manufacturer	Teikei	—	—
Model Number	Y18P-1C	—	—
I.D. Number	46620	—	—
Venturi Size	18φ mm.	—	—
Jet Needle/Clip Position	4D50-2	—	—
Cutaway	2.5	—	—
Pilot Jet	≅44	—	—
Air Jet	2.0	—	—
Starter Jet	≅70	—	—
Air Screw (Turns Out)	1-1/2	—	—
Idle Speed	1,150 ~ 1,250 r.p.m.	—	—
Float Level	0.79 ± 0.098 in. (2.0 ± 2.5 mm.)	—	—
CHASSIS			
Front Brake Shoe Diameter	5.9 ins. (150 mm.)	—	—
Rear Brake Shoe Diameter	5.2 ins. (130 mm.)	—	—
Front Tire			
Manufacturer	YOKOHAMA	—	—
Pressure	23 lbs/in. ² (1.6 kg/cm. ²)	—	—
Rear Tire			
Manufacturer	YOKOHAMA	—	—
Pressure	28 lbs/in. ² (2.0 kg/cm. ²)	—	—
Wheel Run-out Limits-Lateral	0.08 in. (2 mm.)	—	—
Wheel Run-out Limits-Vertical	0.08 in. (2 mm.)	—	—
Drive Chain			
Pitch	DK428	—	—
No. of Links	110L	—	—
Front Fork Oil Capacity (each leg)	137 c.c. (4.6 oz.)	—	—
Type	Yamaha shock fluid	—	—
Steering Ball Race Quantity/Size - (Upper)	19/1/4 in.	—	—
Steering Ball Race Quantity/Size - (Lower)	19/1/4 in.	—	—
Swing Arm Free Play Limits	0.4 in. (1.0 mm.)	—	—

Note:

Yamaha reserves the right to change specifications at any time without prior notice. Should a discrepancy be noted in any procedure or specification within this manual, contact the manufacturer, Yamaha Motor Company, Iwata, Japan; or the U.S.

distributor, Yamaha International Corporation, Buena Park, California; or the Canadian distributor, Yamaha Motor Canada, Ltd., Richmond, B.C. Canada for verification.

MISCELLANEOUS

Torque specifications

The following torque specifications must be adhered to on every machine. Tightening torque, on multi-secured components, several studs should be in gradual stages and in a pattern that will avoid warpage to the item being secured. Torque settings are for dry, clean threads. Torquing should always be done to the nut, never the bolt head.

Note:

Certain items with other than standard thread pitches may require differing torque. Consult the model Service Manual or distributor if a question arises.

Torque specifications

A (Nut)	B (Bolt)	m·kg	lb·ft.	lb·in.
10 mm.	6 mm.	1.0	7.5	90
10 mm.	7 mm.	1.5	11	135
13 mm. 14 mm.	8 mm.	2.0	15	180
17 mm.	10 mm.	3.5 ~ 4.0	20 ~ 29	300 ~ 350
19 mm.	12 mm.	4.0 ~ 4.5	29 ~ 33	350 ~ 400
22 mm.	14 mm.	4.5 ~ 5.0	33 ~ 37	400 ~ 450
26 mm.	17 mm.	5.8 ~ 7.0	40 ~ 50	500 ~ 600
27 mm.	18 mm.	5.8 ~ 7.0	40 ~ 50	500 ~ 600
30 mm.	20 mm.	7.0 ~ 8.3	50 ~ 60	600 ~ 700
SPARK PLUGS		1.5 ~ 1.9	11 ~ 14	135 ~ 170

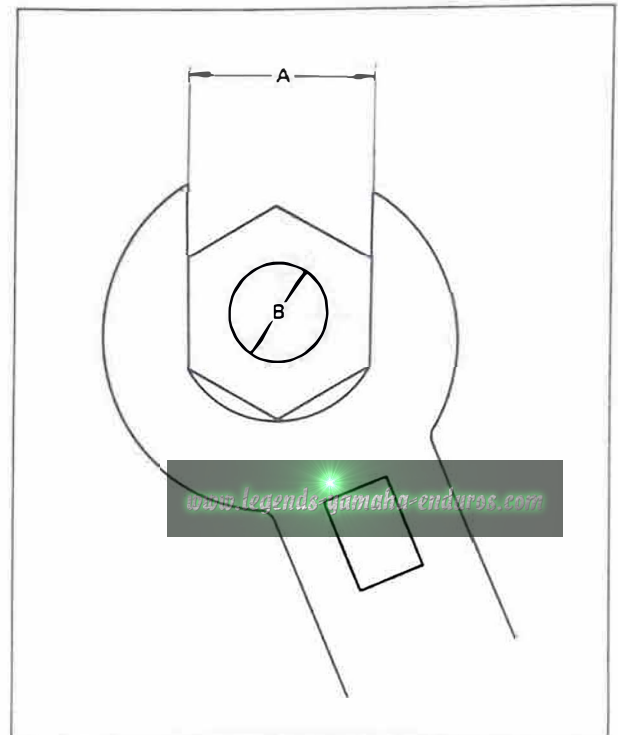

Conversion table

Metric to Inch System

	Known	MULTIPLIER (Rounded off)	Result
TORQUE	m-kg.	7.233	ft-lbs.
	m-kg.	86.80	in-lbs.
	cm-kg.	0.0723	ft-lbs.
	cm-kg.	0.8680	in-lbs.
WT.	kg.	2.205	lb.
	g.	0.03527	oz.
FLOW/DISTANCE	km/ℓ.	2.352	mpg.
	km/hr.	0.6214	mph.
	km.	0.6214	mi.
	m.	3.281	ft.
	m.	1.094	yd.
	cm.	0.3937	in.
	mm.	0.03937	in.
	VOL./CAPACITY	c.c. (cm. ³)	0.03382
c.c. (cm. ³)		0.06102	cu. in.
ℓ. (liter)		2.1134	pt. (U.S. liq.)
ℓ. (liter)		1.057	qt. (U.S. liq.)
ℓ. (liter)		0.2642	gal. (U.S. liq.)
MISC.	kg/mm.	56.007	lb/in.
	kg/cm. ²	14.2234	psi. (lb/in. ²)
	Centigrade (°C)	9/5(°C)+32	Fahrenheit (°F)

Inch to Metric System

	Known	MULTIPLIER (Rounded off)	Result
TORQUE	ft-lbs.	0.13826	m-kg.
	in-lbs.	0.01152	m-kg.
	ft-lbs.	13.831	cm-kg.
	in-lbs.	1.1521	cm-kg.
WT.	lb.	0.4535	kg.
	oz.	28.352	g.
FLOW/DISTANCE	mpg.	0.4252	km/ℓ
	mph.	1.609	km/hr.
	mi.	1.609	km.
	ft.	0.3048	m.
	yd.	0.9141	m.
	in.	2.54	cm.
	in.	25.4	mm.
	VOL./CAPACITY	oz. (U.S. liq.)	29.57
cu. in.		16.387	c.c. (cm. ³)
pt. (U.S. liq.)		0.4732	ℓ. (liter)
qt. (U.S. liq.)		0.9461	ℓ. (liter)
gal. (U.S. liq.)		3.785	ℓ. (liter)
MISC.	lb/in.	0.017855	kg/mm.
	psi. (lb/in. ²)	0.07031	kg/cm. ²
	Fahrenheit(°F)	5/9(°F-32)	Centigrade(°C)

Definition of terms:

m-kg.	=	Meter-kilograms: Usually torque
g.	=	Gram(s)
kg.	=	Kilogram(s): 1,000 grams
km.	=	Kilometer(s)
ℓ.	=	Liter(s)
km/ℓ.	=	Kilometer(s) per liter: Mileage
c.c.	=	Cubic centimeter(s) (cm. ³): Volume or capacity
kg/mm.	=	Kilogram(s) per millimeter: Usually spring compression rate
kg/cm. ²	=	Kilogram(s) per square centimeter: Pressure

RD125B WIRING DIAGRAM

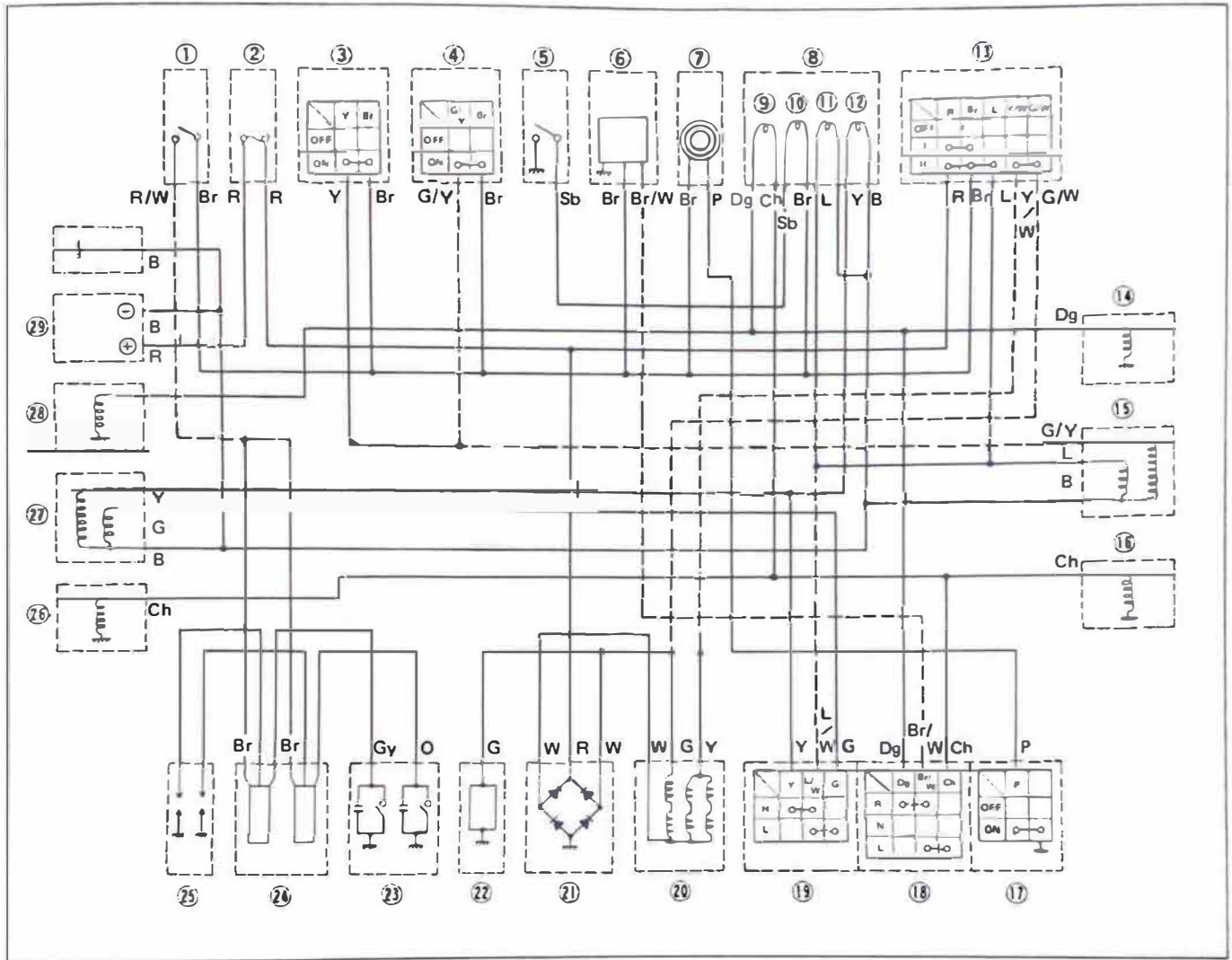

- 1. Engine stop switch
- 2. Fuse
- 3. Rear stop switch
- 4. Front stop switch
- 5. Neutral switch
- 6. Flasher relay
- 7. Horn
- 8. Speedometer
- 9. Flasher pilot light
- 10. Neutral pilot light
- 11. Meter light
- 12. High beam indicator light
- 13. Main switch
- 14. Rear flasher light (R)
- 15. Stop & Tail light

- 16. Rear flasher light (L)
- 17. Horn button
- 18. Signal switch
- 19. Dimmer switch
- 20. AC Generator
- 21. Rectifier
- 22. Voltage regulator
- 23. Condenser & Breaker points
- 24. Ignition coil
- 25. Spark plug
- 26. Front flasher light (L)
- 27. Headlight
- 28. Front flasher light (R)
- 29. Battery

Color cord

R : Red	Ch : Dark Brown
Y : Yellow	Gy : Gray
B : Black	B/R : Black/Red
P : Pink	G/W : Green/White
L : Blue	L/R : Blue/Red
G : Green	Br/W : Red/White
W : White	R/Y : Red/Yellow
Br : Brown	R/W : Red/White
Sb : Sky Blue	L/W : Blue/White
Dg : Dark Green	L/B : Blue/Black

MEMO

MEMO

MEMO

MEMO

MEMO

WIRING AND PIPING

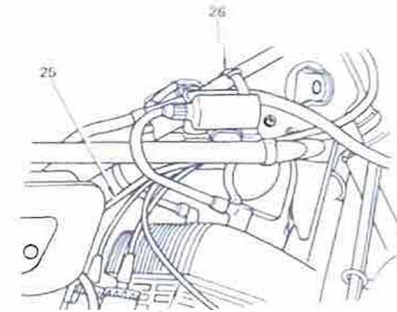
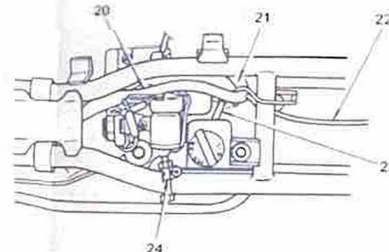
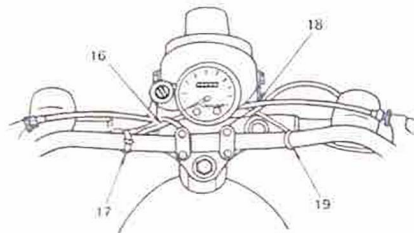
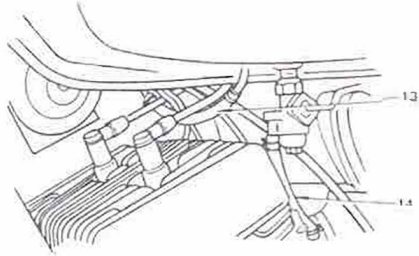
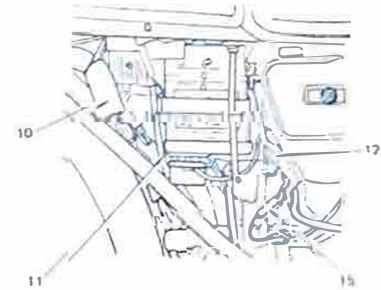
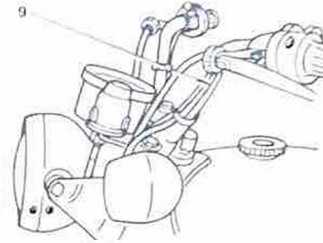
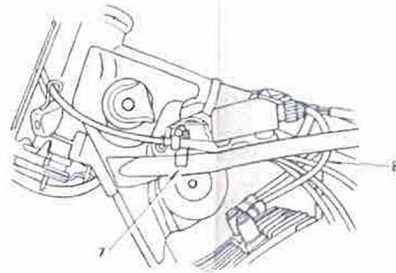
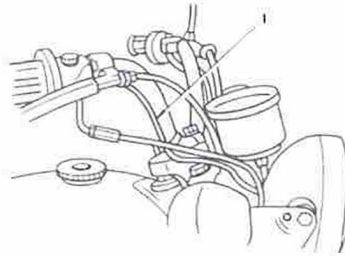
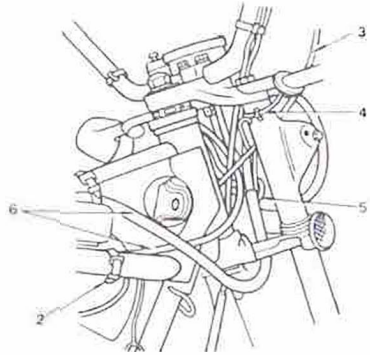

1. Pass stop switch lead wire and switch handle wire along the lower side of the left handlebar. Do not allow too much clearance between each lead and handlebar.
2. Clamp clutch wire with band.
3. Throttle wire, brake wire and clutch wire should be positioned closer to frame than wire harness lead wire, in order of throttle wire, brake wire and clutch wire from frame.
4. Front flasher light lead wires.
Pass along fork, allowing no slack, and clip by bending clip attached to top of lamp stay. Perform the same for both right and left flasher lights.
5. Lead wires to be threaded through headlight body holes.
 - Stop switch lead wire From right lever holder
 - Handle switch lead wires (2) From left lever holder
 - Main switch lead wire
 - Speedometer lead wire
 - Right front flasher light lead wire
6. Clutch wire and wire harness should be positioned as close to frame as possible.
7. Set the gap between wire clip and wire cylinder cap to 0.039 in. (1.0 mm). Changes in the gap caused by machine vibrations will be allowed.
8. Pass throttle wires (2) and pump wire, and clutch wire through between right and left high tension cords.
9. Pass lead wires (2) together along the lower side of the left handlebar. Do not allow too much clearance between each lead wire and handlebar.
10. After connecting lead wires, keep them together.
11. Oil tank breather pipe.
Pass between rear arm cross member and rear part of engine bracket, and extend outside the brake pedal.

12. Wire harness extending to AC generator.
Bring it downward from behind of air cleaner joint, and pass along main pipe.
13. Level pipe should be passed under all wires and cords and inserted into fuel tank. Don't let it slack too much.
14. Pass the fuel pipe (for right carburetor) behind left carburetor throttle wire.
15. Stop switch lead wire.
16. Pass clutch wire and lead wires (2) before handle crown and behind main switch. At the same time, the two lead wires should be positioned outside of clutch wire.
17. Clamp lead wires (2) with band.
18. Brake wire and lead wires (2) should be passed before handle crown. The two lead wires should be outside of brake wire.
19. Clamp lead wires (2) with hand.
20. After connecting lead wires, keep them together.
21. Hook wire harness.
22. Connect to rear flasher light lead wire in the center of gear leader.
23. Extend oil tank breather pipe downward.
24. Ground.
25. Pass clutch wire under coil bracket, and pass over throttle wires (2) and pump wire.
26. Clamp wire harness with band (at two places).
27. Pump wire should be at least 15 mm off cylinder rim.
28. Wire harness should be so installed as not to contact shaft damper clip.
29. After threading speedometer cable and brake wire, clamp by bending wire guide inward. Do the same for both right and left side.
30. After threading throttle wire, bend wire guide against head pipe.

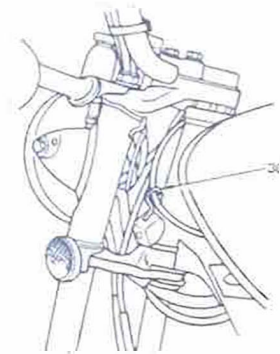
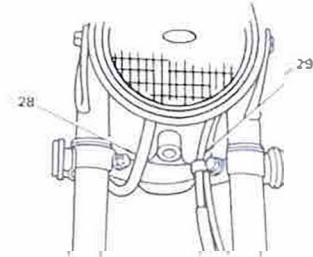

www.legends-yamaha-enduros.com



SINCE 1887

YAMAHA MOTOR CO., LTD.

IWATA, JAPAN

LIT-11664-00-09

PRINTED IN JAPAN
74 - 8 - 2.6 x 1 ©