



YAMAHA

RD 200 C

OWNER'S MANUAL

www.legends-yamaha-enduros.com

581-28199-10

RD200C OWNER'S MANUAL

1ST PRINTING

MARCH 1975

**ALL RIGHTS RESERVED,
BY YAMAHA MOTOR COMPANY**

LIMITED, JAPAN

PRINTED IN JAPAN

P/N LIT-11625-07-01

INTRODUCTION

Thank you for buying the Yamaha RD200C.

This model is the product of many years of Yamaha experience and strict Yamaha quality control. The resultant ease of handling, high performance and reliability promise you full pride of ownership.

This manual is written in such a way as to provide the owner with a good understanding of the features, operation, maintenance and inspection of this manual, so read it carefully and completely before operating the vehicle. If you have any questions concerning the information, ask your dealer before operating the vehicle.

www.legends-yamaha-enduros.com

NOTICE

Some data in this manual may become outdated due to improvements made to the machine in the future. If there is any question concerning this manual, consult your nearby Yamaha dealer.

SERVICE DEPT.
OVERSEAS ENGINEERING DIVISION
YAMAHA MOTOR CO., LTD.

www.legends-yamaha-enduros.com

CONTENTS

| | |
|--|----|
| FEATURES | 1 |
| NOMENCLATURE | 3 |
| MACHINE IDENTIFICATION | 4 |
| SPECIFICATIONS | 5 |
| CONTROL FUNCTIONS | 8 |
| PREOPERATION CHECKS | 21 |
| OPERATION AND IMPORTANT DRIVING POINTS | 27 |
| PERIODIC MAINTENANCE AND MINOR REPAIR | 36 |
| TROUBLESHOOTING | 80 |
| CLEANING AND STORAGE | 82 |
| MISCELLANEOUS | 85 |

FEATURES

Torque Induction system

The Torque Induction system is a completely new air/fuel mixture intake method. Intake efficiency is increased by the 7-port cylinder and reed valve assembly. This combination provides improved performance, especially, at low and midrange r.p.m.

Starter equipped carburetor

The carburetor on this vehicle has a separate starter system. By merely operating the starter (choke) knob a rich mixture is supplied to the engine when starting.

This makes starting easy even in cold weather.

Yamaha Autolube

Yamaha pioneered separate, automatic lubrication in the motorcycle industry by developing the Yamaha Autolube pump. Only pure gasoline is stored in the fuel tank so there is no need to mix with oil when filling the tank.

The Autolube pump supplies the proper amount of oil according to engine speed and throttle opening. This serves to lengthen the life of the engine and increases economy of operation.

Primary kick starting system

You can use the kick starter in any gear by merely disengaging the clutch. It is not necessary to shift back to neutral if the engine dies. This feature is a great advantage for both street and off-road operation.

Disc brake

The large diameter front disc brake never fades at high speeds.

Braking is always stable. The brake features automatic adjustment as the pads wear. The pad is provided with a wear indicator so a glance tells you the condition of the brake without disassembly.

www.legends-yamaha-enduros.com

Starter generator

The starter generator starts the engine using the current from the battery. After starting the engine it operates as a generator and recharges the battery.

NOMENCLATURE

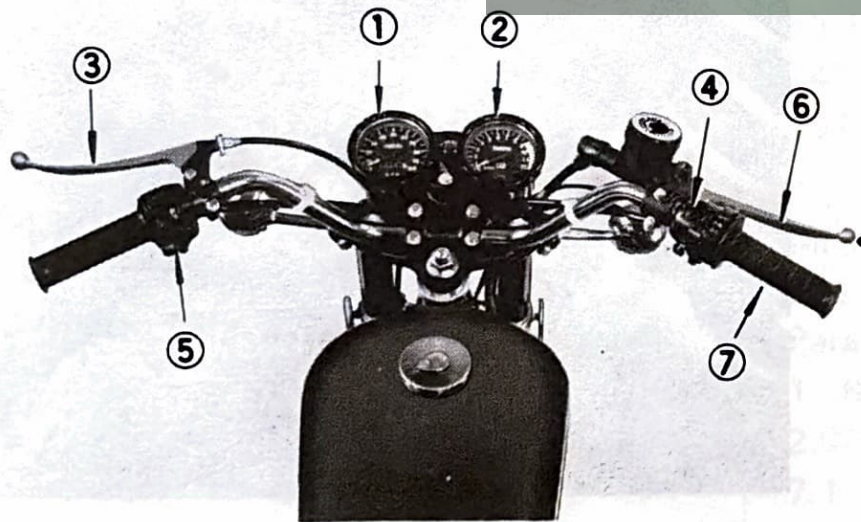
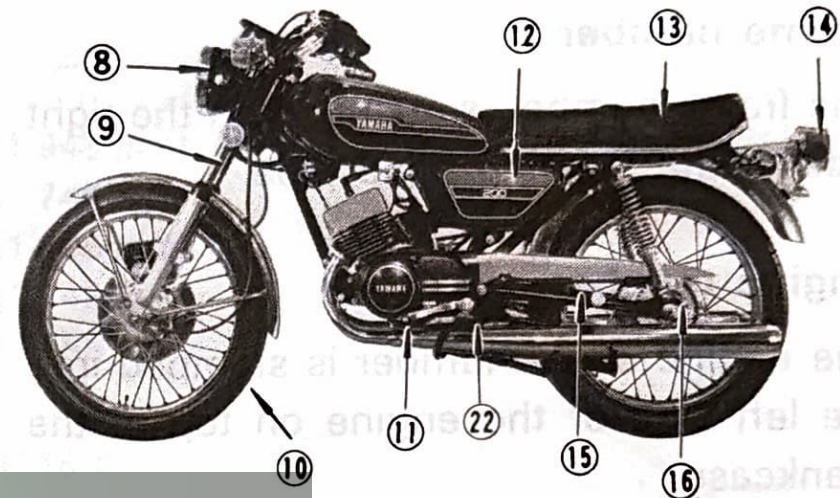
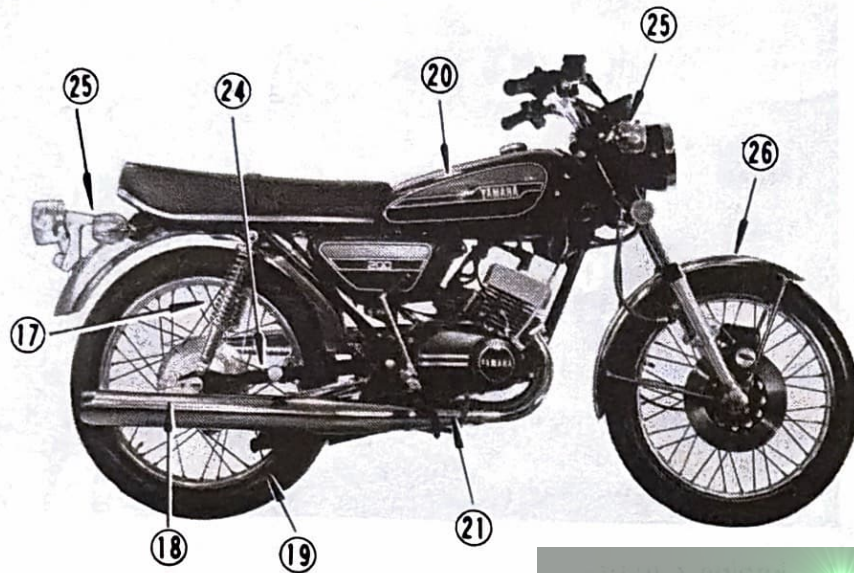

www.legends-yamaha-enduros.com

- | | |
|-----------------------|--------------------------|
| 1. Speedometer | 14. Tail/Stop light |
| 2. Tachometer | 15. Chain |
| 3. Clutch lever | 16. Sprocket |
| 4. Engine stop switch | 17. Rear shock absorber |
| 5. Handle switch | 18. Muffler |
| 6. Brake lever | 19. Rear wheel |
| 7. Throttle grip | 20. Fuel tank |
| 8. Headlight | 21. Brake pedal |
| 9. Front fork | 22. Footrest |
| 10. Front wheel | 23. Kick crank |
| 11. Change pedal | 24. Footrest (passenger) |
| 12. Oil tank | 25. Flasher light |
| 13. Seat | 26. Front fender |

MACHINE IDENTIFICATION

Frame number

The frame number is stamped on the right side of the steering head pipe.

Engine number

The engine serial number is stamped into the left side of the engine on top of the crankcase.

NOTE:

The first three digits of these numbers are for model identifications; the remaining digits are the unit production number. The two serial numbers are usually identical but they may sometimes be 2 or 3 numbers apart.

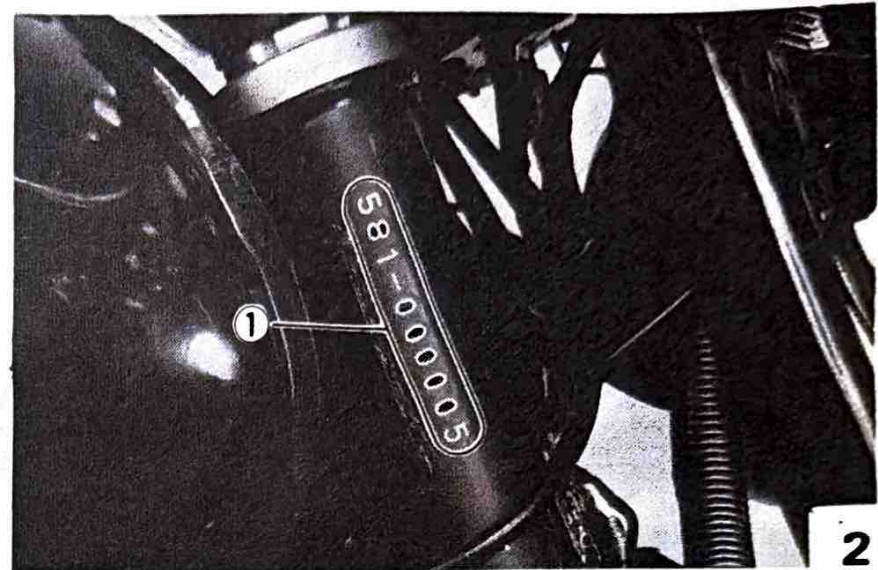

2

1. Engine number



3

1. Frame number

SPECIFICATIONS

| Model | RD200C |
|------------------------|--|
| Dimensions: | |
| Overall length | 76.6 in (1,945 mm) |
| Overall width | 29.1 in (740 mm) |
| Overall height | 39.6 in (1,005 mm) |
| Wheelbase | 49.0 in (1,245 mm) |
| Minimum road clearance | 6.1 in (155 mm) |
| Weight: | |
| Net | 256 lb (116 kg) |
| Performance: | |
| Maximum speed | 84 mi/h (135 km) |
| Minimum turning radius | 82.7 in (2,100 mm) |
| Climbing capacity | 24° |
| 400 meter acceleration | 16.0 sec. |
| Engine: | |
| Type | Air-cooled, 2-stroke, gasoline, Torque Induction |
| Engine model | 581 |
| Cylinder | Parallel twin, forward inclined |
| Displacement | 11.89 cu. in (195 cc) |
| Bore and stroke | 2.05 × 1.81 in (52 × 46 mm) |
| Compression ratio | 7.1 : 1 |

| Model | RD200C |
|----------------------------|--|
| Starting system | Primary kick & Electric starter |
| Ignition system | Battery |
| Gasoline tank capacity | 3.0 U.S. gal (11.5 lit) |
| Oil tank capacity | 2.1 U.S. qt (2.0 lit) |
| Transmission oil capacity | 0.79 ± 0.05 U.S. qt (750 ± 50 cc) |
| Lubricating system | Separate lubrication (Yamaha Autolube) |
| Battery capacity | 12V, 9AH |
| Battery | 12N9-3A-1 |
| Generator system | Stator dinamo |
| Generator | GS214-02 |
| Generator manufacturer | HITACHI |
| Spark plug | NGK B-8ES × 2 |
| Carburetor | Y20P × 2 |
| Air cleaner | Oiled foam rubber |
| Transmission: | |
| Primary reduction system | Gear, helical type |
| Primary reduction ratio | 53/16 (3.312) |
| Secondary reduction system | Chain |
| Secondary reduction ratio | 36/14 (2.571) |
| Clutch | Wet, multi-disc |
| Gear box | Constant mesh, 5-speed |
| Operating system | Left foot-operated, ratcheting system |

| Model | | RD200C |
|-------------------|--------|---------------------------------|
| Gear ratio: | First | 34/12 (2.833) |
| | Second | 29/17 (1.705) |
| | Third | 25/20 (1.250) |
| | Fourth | 23/22 (1.045) |
| | Fifth | 22/24 (0.916) |
| Steering: | Caster | 62°30' |
| | Trail | 3.74 in (95 mm) |
| Tire size | Front | 2.75-18-4PR |
| | Rear | 3.00-18-4PR |
| Suspension: | Front | Telescopic fork |
| | Rear | Swing arm |
| Shock absorber: | Front | Coil spring, oil damper |
| | Rear | Coil spring, oil damper |
| Frame: | | Steel tubing, diamond structure |
| Braking system: | | |
| Type of brake, | Front | Disc |
| | Rear | Drum |
| Operation system, | Front | Right hand operation |
| | Rear | Right foot operation |

CONTROL FUNCTIONS

Main switch

The following chart shows the key position at which the lights, horn and ignition circuit are switched on or off: (The circle (○) denotes "Switch on")

| Part name | Key position | | | | Instructions |
|------------------|--------------|---|----|-----|--------------------------------|
| | OFF | I | II | III | |
| Ignition circuit | | ○ | ○ | | Kick starting |
| Headlight | | ○ | | ○ | — |
| Taillight | | ○ | | ○ | — |
| Neutral light | | ○ | | | Gear box is in neutral |
| Stoplight | | ○ | | | The brake is applied |
| Meterlight | | ○ | | ○ | — |
| Horn | | ○ | | | Push the left handlebar button |
| Flasher lights | | ○ | | | Turn on left handlebar switch |

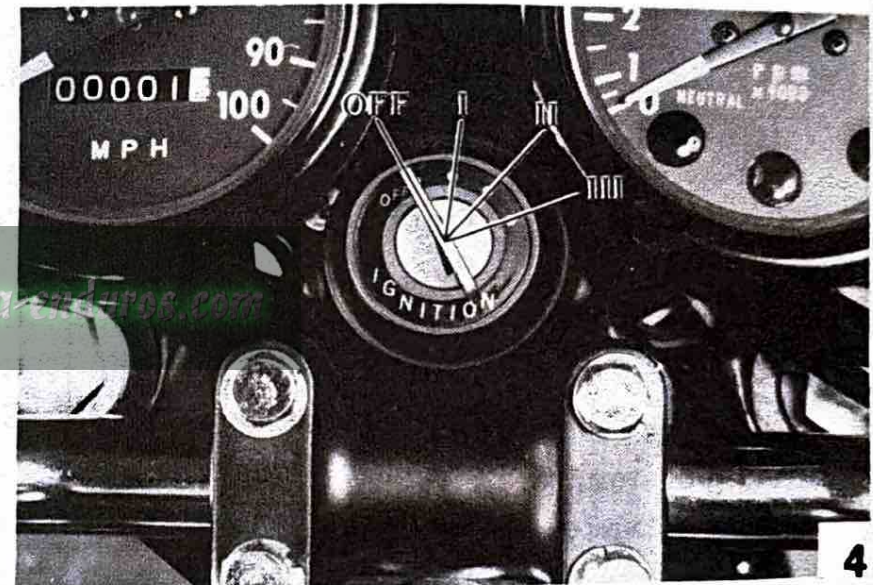

Handle switches

The handle switches are located near the right and left handle grips (see illustration) and are used for the following functions:

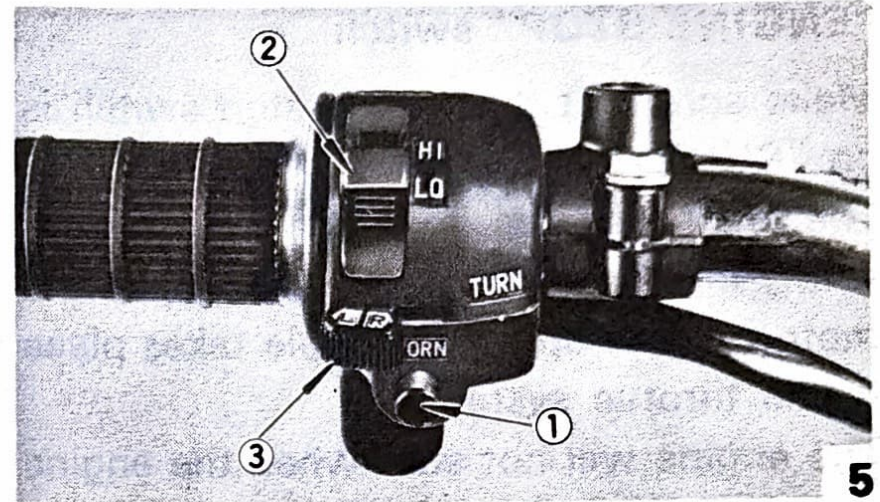

- 1. Horn button
- 2. Dimmer switch

- 3. Turn switch

www.legends-yamaha-enduro.com

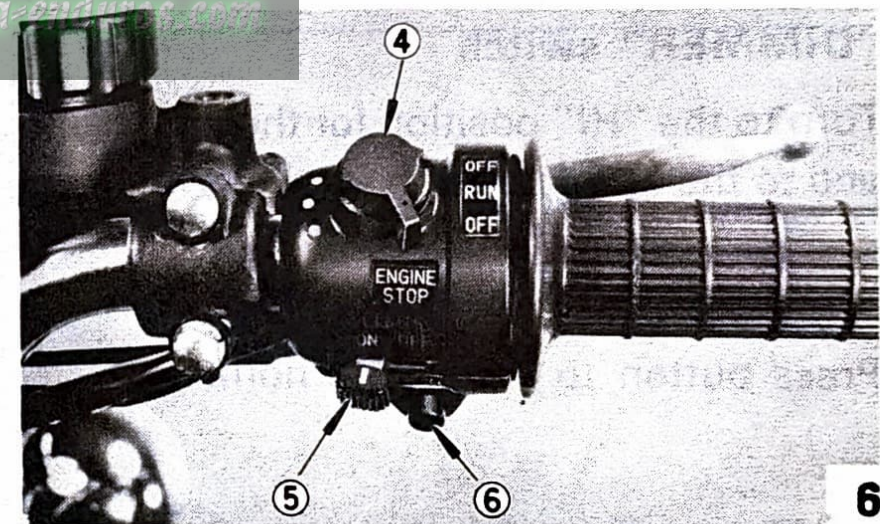

- 4. Engine stop
- 5. Lighting switch

- 6. Starter button

“ENGINE STOP” switch

Make sure that the engine stop switch is on “RUN”.

The engine switch is equipped to ensure safety in an emergency such as when the motorcycle is upset or trouble takes place in the throttle system.

The engine will not start when the engine switch is turned to “OFF”.

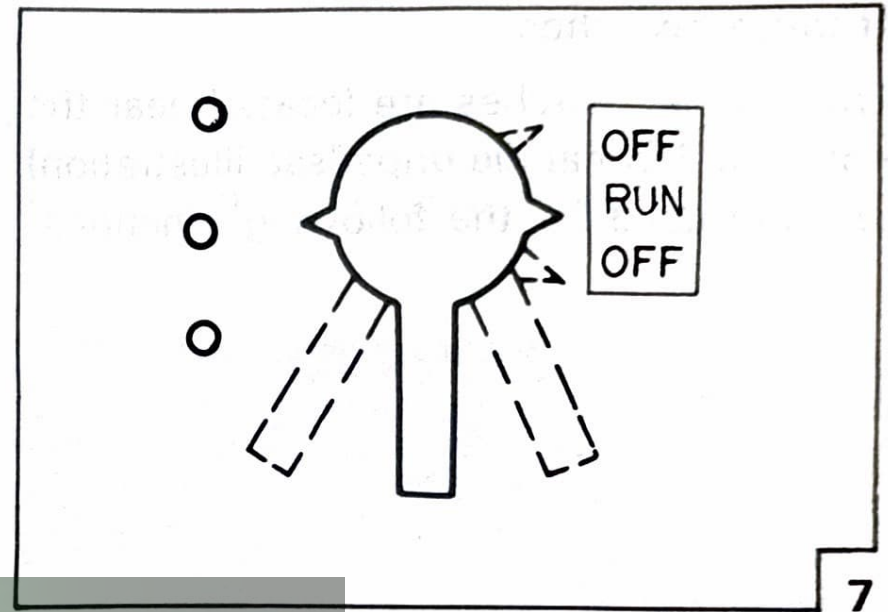

“DIMMER” switch

Turn to the “HI” position for the high beam and to the “LO” position for the low beam.

“HORN” button

Press button to sound the horn.

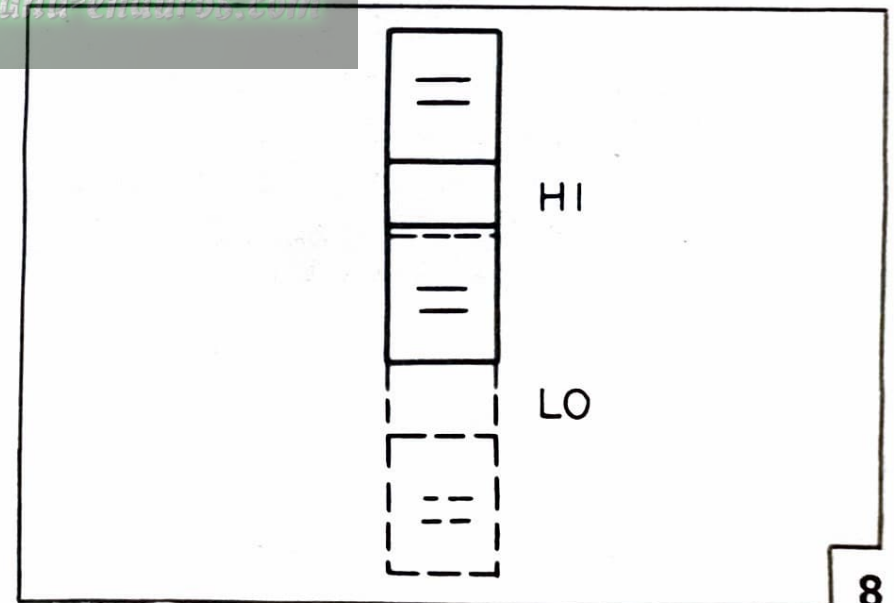

“TURN” switch

This is a three-way switch: The center position is off, turn to the “L” position for the left flasher and to the “R” position for the right flasher.

Starter button

Press the button to activate the starter. Take your finger off the button immediately after the engine starts.

www.legends-yamaha-enduros.com

Lighting switch

Turn the light switch to the ON position to turn on the headlight and taillight.

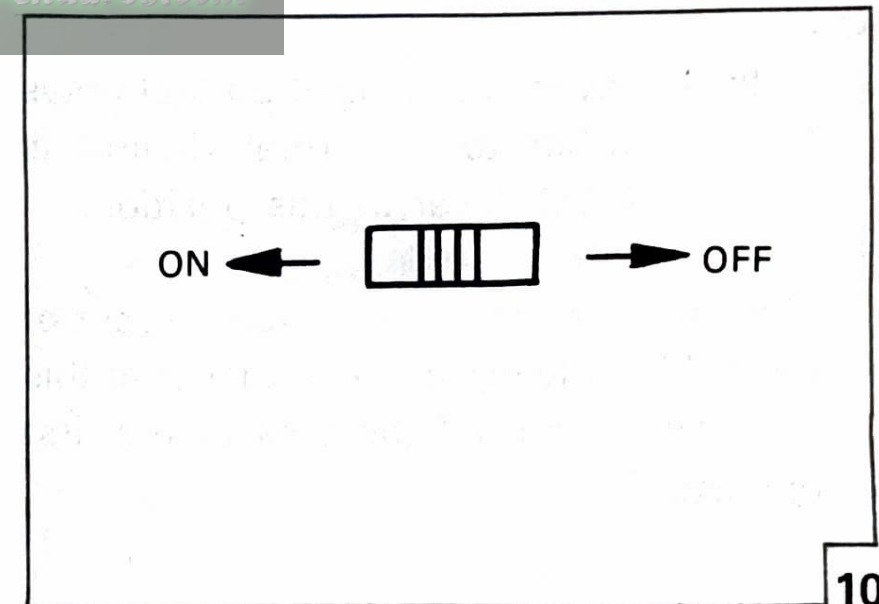
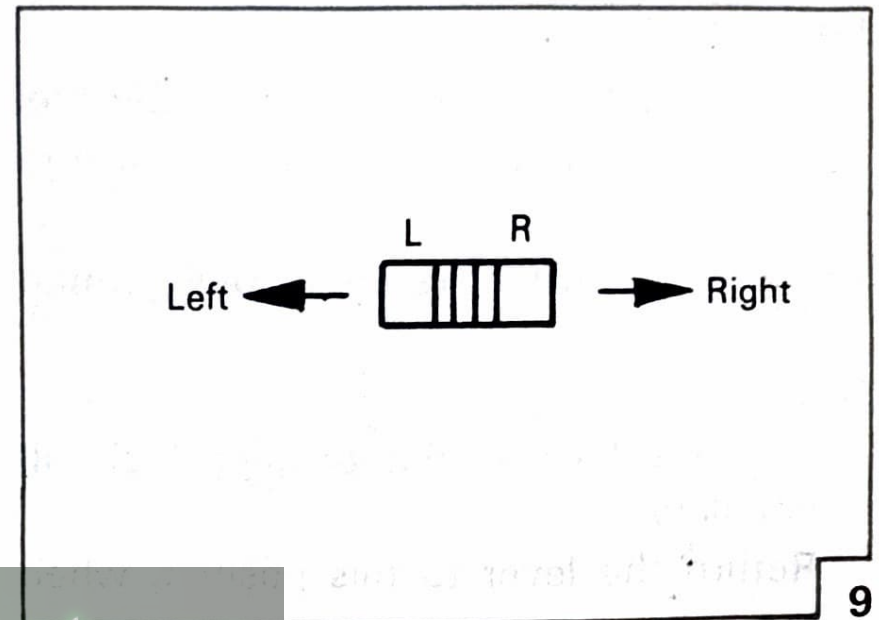

Fuel petcock

The fuel petcocks function to supply fuel from the tank to the carburetor and also to filter the fuel.

The fuel petcocks have the following three positions:

OFF:

With the lever in this position fuel will not flow.

Return the lever to this position when the engine is not running.

ON:

With the lever in this position fuel flows to the carburetor. Normal driving is done with the lever in this position.

RES:

This indicates reserve. If you run out of fuel while driving, move the lever to this position. Then, fill the tank at the first opportunity.

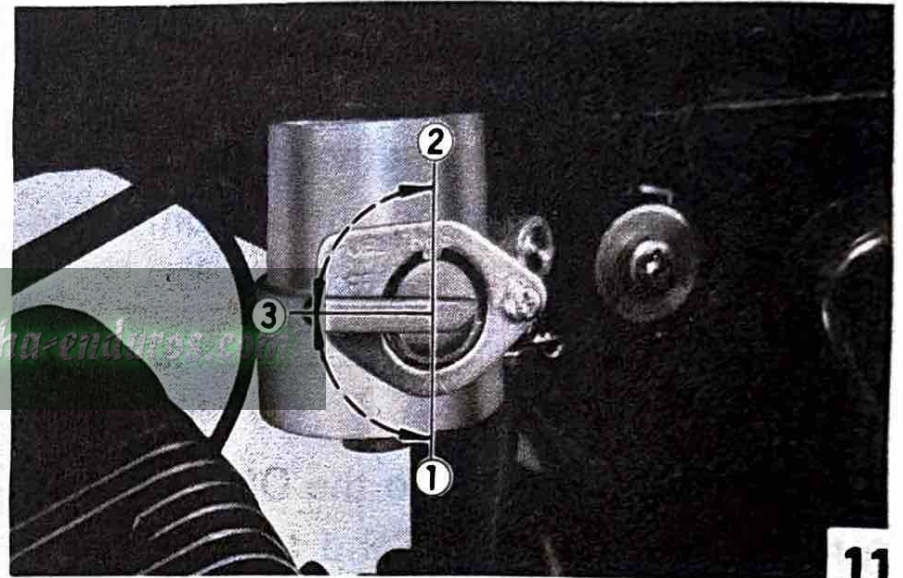

1. On

2. Reserve

3. Off

11

Indicator lights

- * Flasher pilot light (orange)
The pilot light flashes when the flasher switch is "ON".
- * Neutral light (green)
This light is located on the face of the tachometer and lights when the transmission is in neutral.
- * High beam indicator "BEAM" (blue)
This indicator lights when the headlight high beam is used.
- * Charge light (red)
Charge light goes out when charging out.

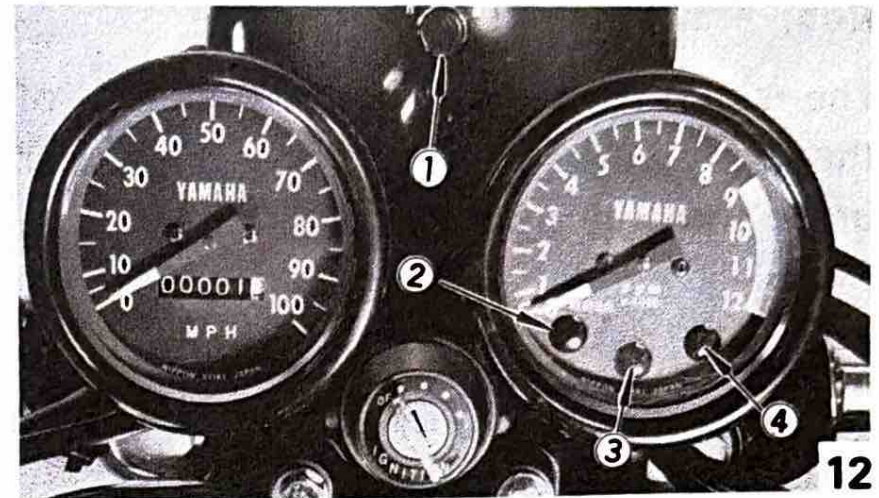

1. High beam indicator light
2. Neutral light

3. Flasher pilot light
4. Charge light

www.legends-yamaha-enduros.com

Front brake lever

The front brake lever is located on the right handlebar; pivot it forward the handlebar to activate the front brake.

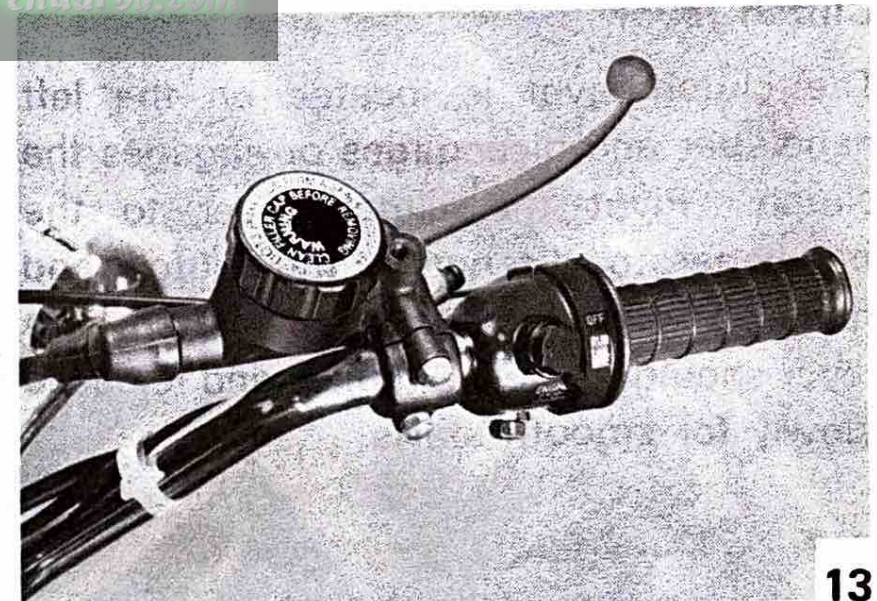

Rear brake pedal

The rear brake pedal is on the right side of the motorcycle and activates the rear brake through a link rod.

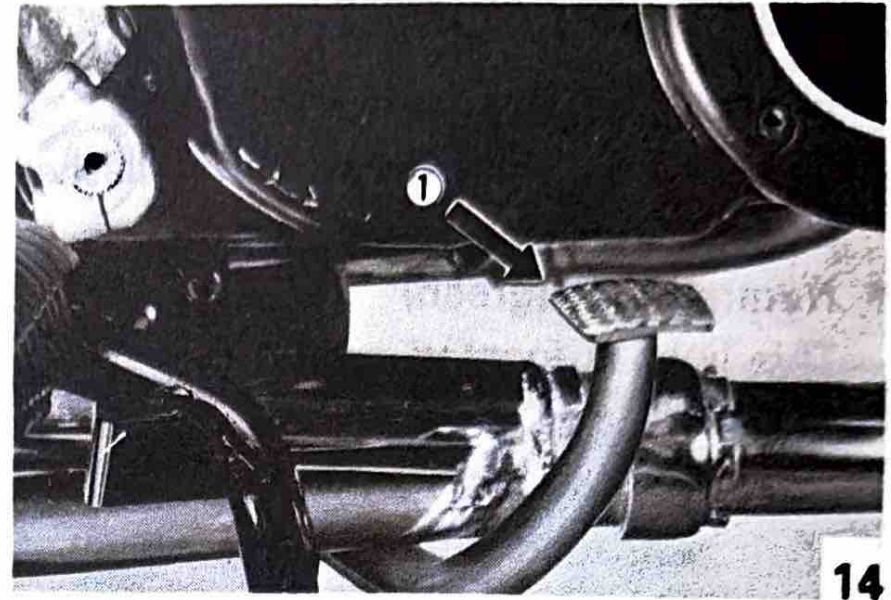

14

1. Brake pedal

www.legends-yamaha-enduras.com

Clutch lever

The clutch lever is located on the left handlebar and disengages or engages the clutch. Pivot the clutch lever to the handlebar to disengage the clutch and release the lever to engage the clutch. The lever should be pulled rapidly and released slowly for smooth starts.

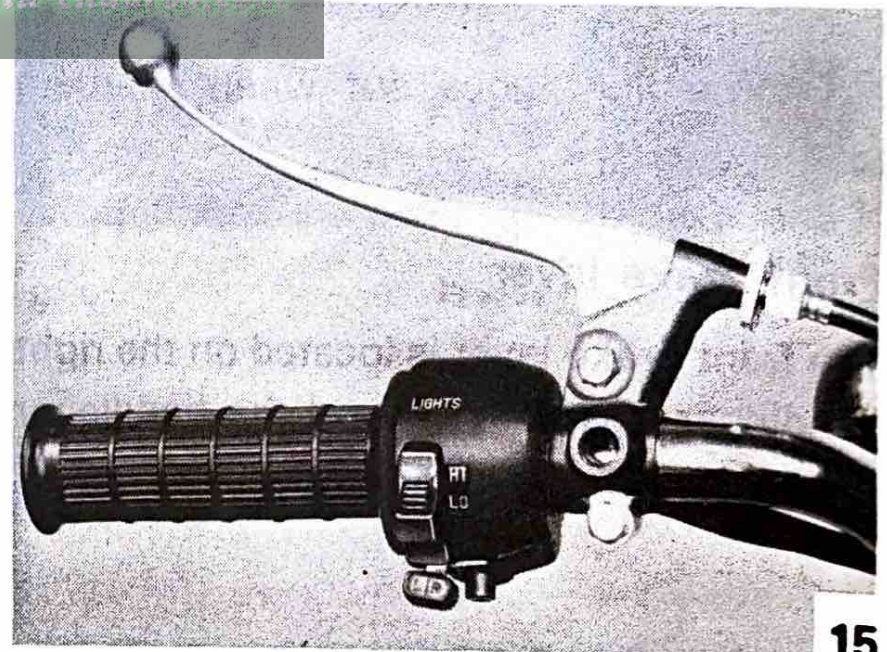

15

Gear shifting

The gear ratios of the constant mesh 5-speed transmission are ideally spaced. The gears can be shifted by using the change pedal on the left side of the engine. Refer to the illustration for the gear shifting pattern.

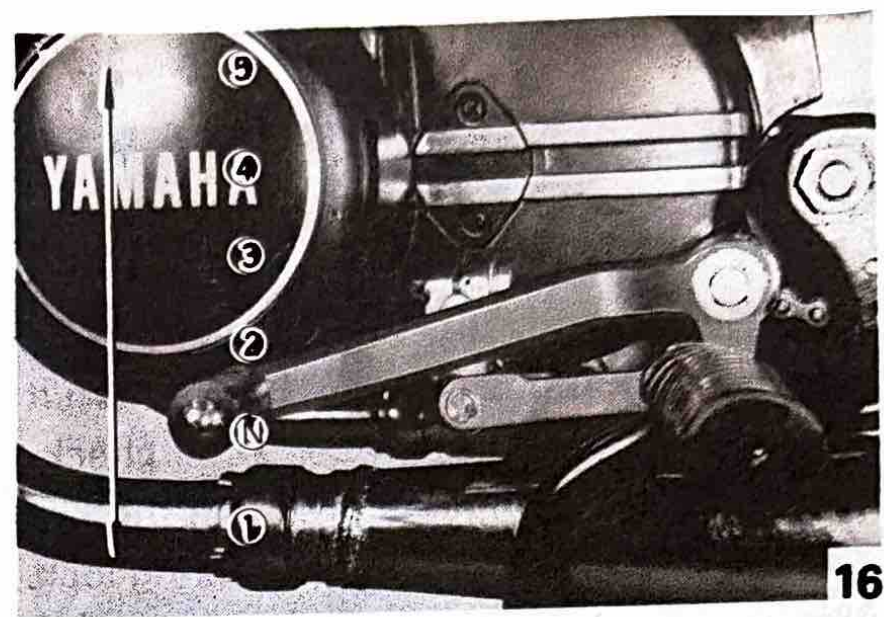

1. FIRST
2. SECOND

3. THIRD
4. FOURTH

5. FIFTH
N. NEUTRAL

Starter knob (choke knob)

When cold the engine requires a richer fuel mixture for starting. A separate starter circuit, which is controlled by the starter knob, supplies this mixture.

Pull knob out to open circuit (for starting) and push knob in to close circuit.



Steering lock

To lock the steering, turn the handlebars fully to the left, insert the key into the steering lock and turn the key about 45° clockwise; then push the key in and turn it about 45° counterclockwise. After checking if the lock is engaged, remove the key from the lock. To release the steering lock, reverse the above steps.

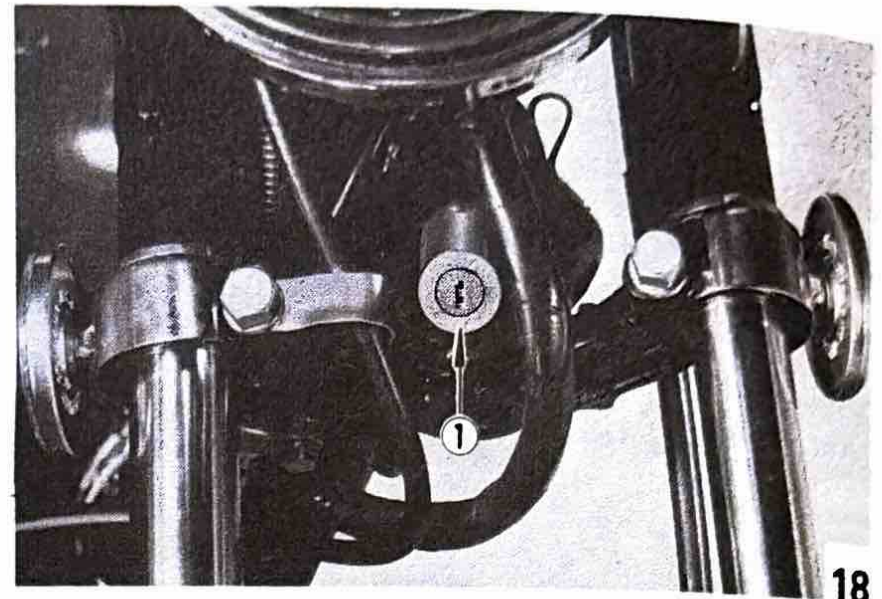

18

1. Steering lock

Fuel tank filler cap

The locking fuel tank filler cap can be removed as follows: Rotate the cover to one side, insert the key and turn it 90° counterclockwise. The cap can then be removed by turning counterclockwise and lifting. To relock the cap, set it in place and turn it clockwise. Then turn the key 90° clockwise, remove key and rotate the cover over the keyhole.



19

1. Cover

Seat lock

To open the seat lock, insert the key into the keyhole and turn it about 1/4 clockwise.

To lock, insert the key and turn it about 1/4 counterclockwise.

Seat latch

The seat is hinged to the frame on one side and secured by the seat latch on the other side. To add engine oil or take out the service tools, pull the seat latch lever out, free the seat latch from the hook and lift the seat.

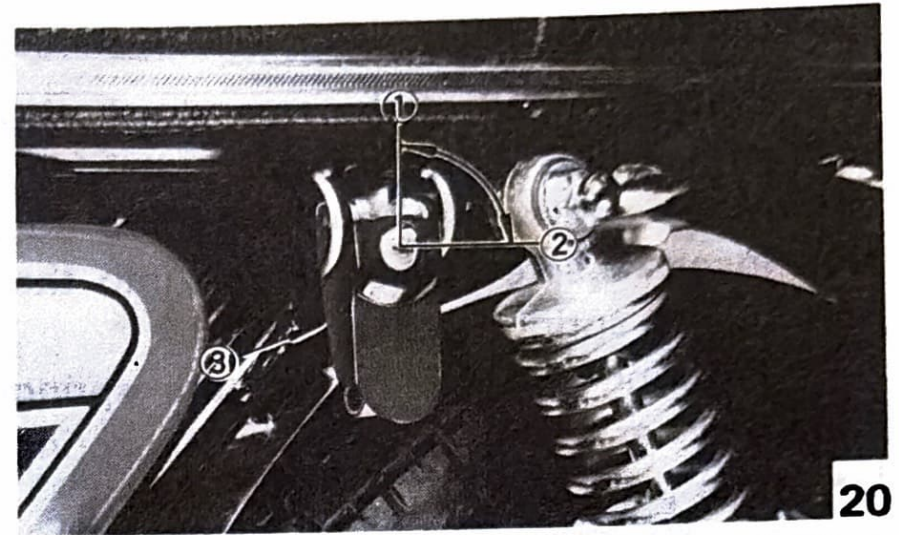

1. Lock

2. Unlock

3. Seat latch

Rear shock absorber

The spring preload of the rear shock absorber can be adjusted to suit rider preference and riding conditions. To adjust, insert a screwdriver or rod into the hole in the spring holder.

If the spring seat is raised, the spring becomes harder and if lowered, the spring becomes softer.

NOTE:

Adjust both the right and left sides to the same position.

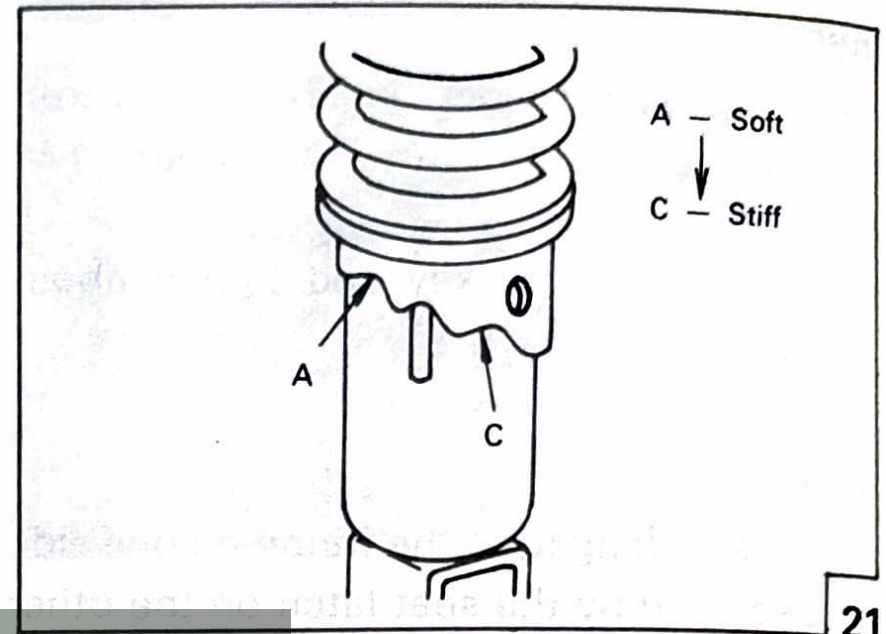

Meters

1. Speedometer
2. Odometer
3. Tachometer

Tachometer

The tachometer is provided so the rider can keep engine r.p.m.s within the ideal power range. The tachometer can be used as follows:

To obtain maximum performance, run the engine up to the recommended r.p.m. range in each gear. In this range the engine performs with maximum efficiency and minimum wear. Never operate the engine outside the recommended range.

Recommended r.p.m. range:

4,000 ~ 7,000 r.p.m.

Do not operate in the red zone.

Red zone

9,000 ~ 12,000 r.p.m.

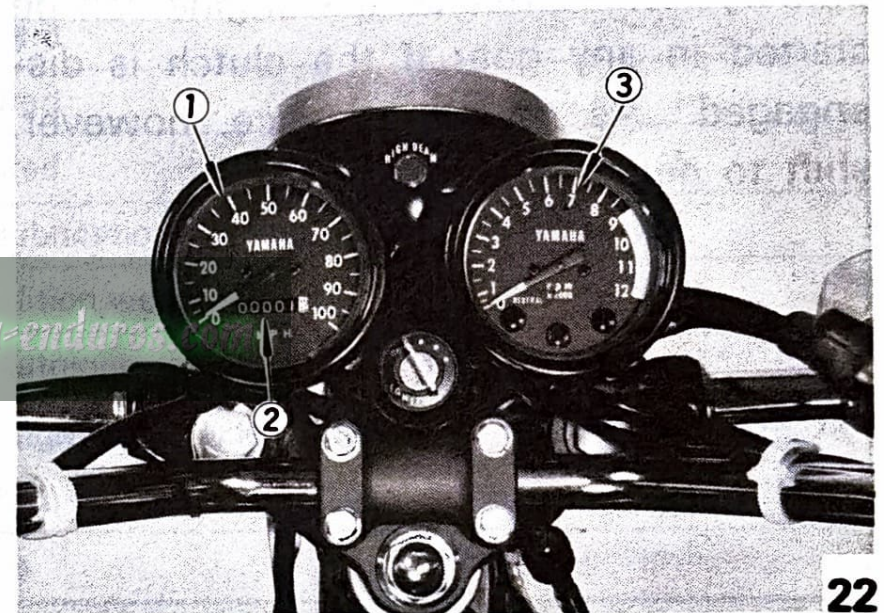

Kick starter

To start the engine, rotate the kick crank as shown in the illustration, push down lightly with foot until gears engage, and then kick with full strength. This model has the primary kick starter so the engine can be started in any gear if the clutch is disengaged. As normal practice, however, shift to neutral before starting.

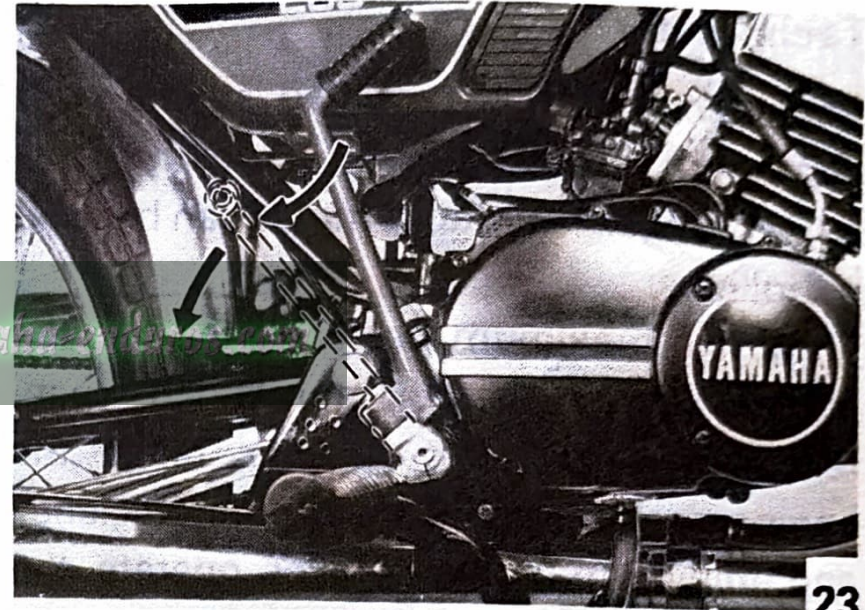

23

PREOPERATION CHECKS

Before using this motorcycle please check the following points:

| Item | Routine | Page |
|--------------------|--|---------------------|
| Brakes | Check operation/adjustment | 24, 25, 59 ~ 62, 75 |
| Clutch | Check operation/lever adjustment | 25, 57, 58 |
| Autolube tank | Check oil level/top-off as required | 22, 43 |
| Transmission | Check oil level/top-off as required | 22, 44, 45 |
| Drive chain | Check alignment/adjustment/lubrication | 63 ~ 66 |
| Spark plug(s) | After break-in check color/condition weekly/500 miles | 46, 47 |
| Throttle | Check for proper throttle and Autolube cable operation | 26, 53 ~ 55 |
| Wheels and tires | Check pressure/runout spoke tightness/axle nuts | 23, 69 ~ 74, 76, 78 |
| Fittings/fasteners | Check all - tighten as necessary | 42 |
| Lights/signals | Check headlight/tail - stoplights | 26 |

NOTE:

Pre-operation checks should be made each time the machine is used. Such an inspection can be thoroughly accomplished in a very short time; and the added safety it assures is more than worth the time involved.

Fuel

Make sure there is sufficient fuel in the tank.

Recommended gasoline: 90 octane

Fuel tank capacity: 3.0 U.S. gal (11.5 lit)

Engine oil

Make sure there is sufficient engine oil in the Autolube tank. Add oil as necessary.

Recommended oil:

See page 43, "Engine oil section"

Autolube tank capacity:

2.1 U.S. qt (2.0 lit)

Transmission oil

Make sure the transmission oil is at the specified level. Add oil as necessary.

Recommended oil:

SAE 20W/40 weight "SE" motor oil

Oil quantity:

0.79±0.05 qt (750±50 cc)

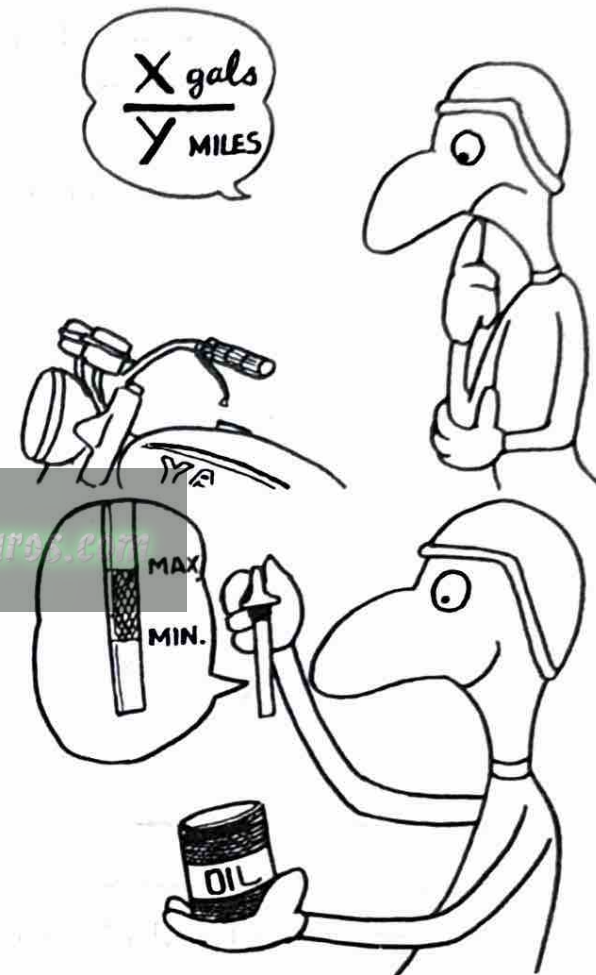

Tires

Check the tire pressure and check tires for wear.

Tire pressure:

| | | |
|-------|--|-------------------|
| Front | 23 lbs/in ² (1.6 kg/cm ²) | Normal riding |
| Rear | 28 lbs/in ² (2.0 kg/cm ²) | |
| Front | 28 lbs/in ² (2.0 kg/cm ²) | High speed riding |
| Rear | 34 lbs/in ² (2.4 kg/cm ²) | |

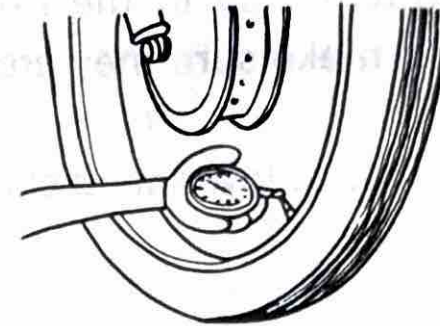

If a tire tread shows crosswise lines, it means that the tire is worn to its limit. Re-[place the tire.](http://www.yamaha-enduros.com)

CAUTION: _____

A great danger is apprehended from driving with a worn tire. When a tire tread begins to show lines, have your Yamaha dealer replace the tire immediately

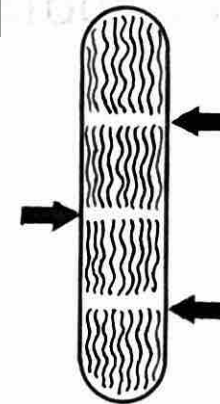

Brake lever and brake pedal

Check for correct play in the brake lever and pedal and make sure they are working properly.

Check the brakes at low speed shortly after starting out.

Brake fluid

Remove the reservoir tank cap and check the brake fluid level. Add fluid if necessary.

Recommended fluid: DOT#3 or DOT#4

Capacity: 55 cc

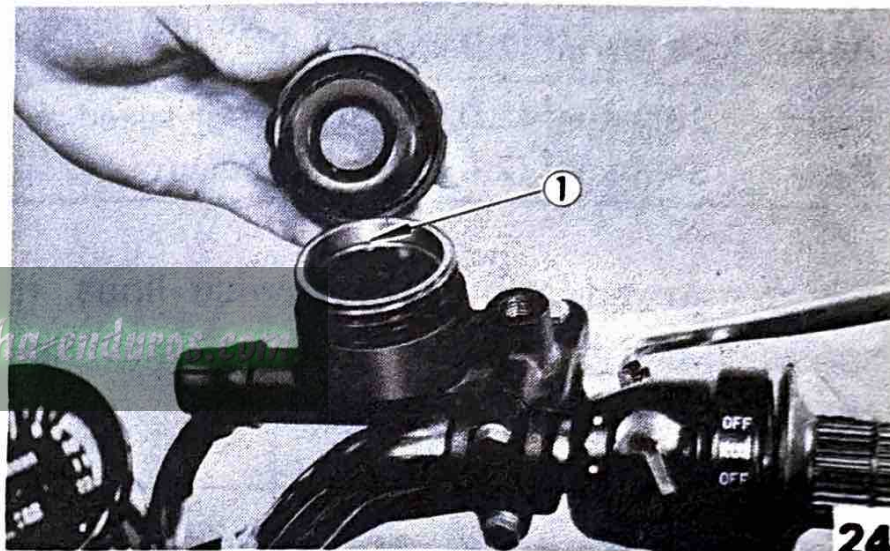

1. Fluid low level

Checking the disc brake pads

For easy check of wear on the disc brake pads, a wear indication line is attached to each brake pad. This indication line permits a visual check without disassembling the pads.

To check, apply the brake, and measure the gap between the disc and the inner pressure plate. If the gap measures less than 0.059 in (1.5 mm) have your yamaha dealer replace the pads.

www.legends-yamaha-enduros.com

Front brake fluid leakage

Squeeze the brake lever for a few minutes, and check to see if any brake fluid leaks out from pipe joints or the cylinder.

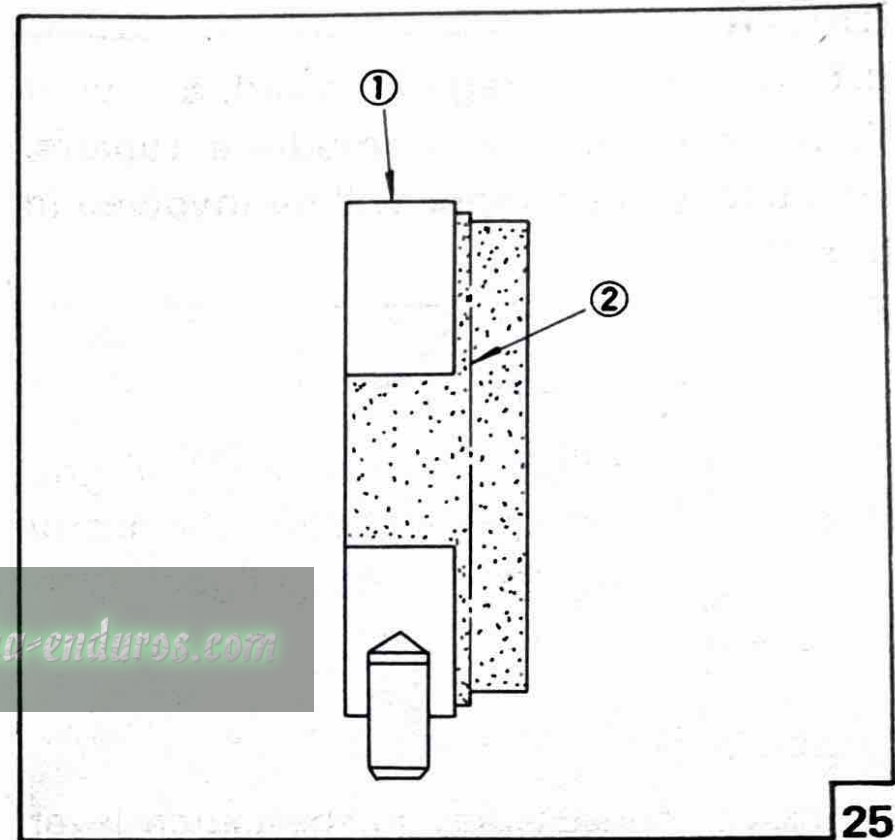

1. Inner pressure plate
2. Wear indication line

CAUTION: _____

If brake fluid leakage is found, ask your Yamaha dealer for immediate repairs, because great danger will be involved in this leakage.

Lights and signals

Check the headlight, flasher lights, taillight, stoplight, meter light and all the indicator lights to make sure they are in good working condition.

Clutch lever

Check for correct play in the clutch lever and make sure the lever operates properly.

Speedometer and tachometer

Check for proper operation.

Switches

Check the operation of the headlight switch, the turn switch, stoplight switch, horn button, main switch, etc.

Throttle grip

Turn the throttle grip to see if it operates properly and if the play is normal. Make certain the throttle grip closes when released.

OPERATION AND IMPORTANT DRIVING POINTS

CAUTION: _____

Before riding this motorcycle, become thoroughly familiar with all operating controls and their function.

Consult your Yamaha dealer regarding any control or function you do not thoroughly understand.

Starting a cold engine

1. Turn the fuel petcock to "ON".
2. Turn the ignition key to the "I" position and turn the engine stop switch to the "RUN" position.
3. Operate the carburetor starter jet (choke) knob and completely close the throttle grip.
4. Kick the kick crank with full strength or press the starter button to start the engine.

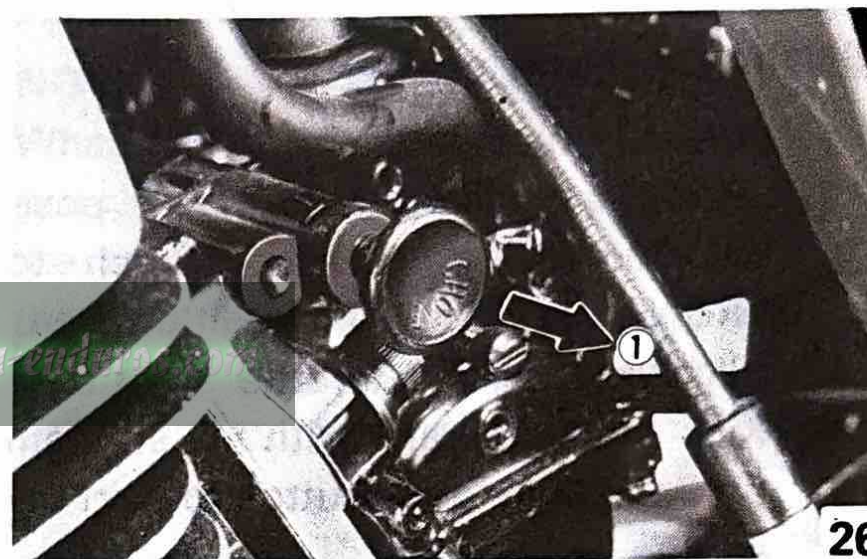

1. Pull

5. After the engine starts, warm up for one or two minutes.

Make sure the starter jet (choke) knob is returned to the original position before driving.

Starting a warm engine

1. Turn the fuel petcock to "ON".
2. Turn the ignition key to the "I" position and engine stop switch to "RUN".
3. Slightly open the throttle grip.
4. Kick the kick crank with full strength or press the starter button to start the engine.

NOTE: _____

Do not operate the starter (choke) knob when the engine is already warm.

CAUTION: _____

See "Break-in Section" prior to operating engine for the first time.

Warming up

To get maximum engine life, always "warm up" the engine before starting of. Never accelerate hard with a cold engine. To see whether or not the engine is warm, see if it responds to throttle normally with the starter (choke) turned off.

Brake operation

Brakes are provided to stop the moving motorcycle; however, care must be exercised when braking at high speeds or under poor driving conditions such as rough roads, snow, rain, etc.

Several braking methods are described below for your information. Pulling in the clutch lever and twisting the throttle grip in the closed direction will permit you to gradually glide to a stop. Downshifting through the gears, using the drag of the engine to slow down is another. However,

the best method, and the one most universally used, is to use both engine braking (downshifting through the gears as the machine slows) and the front and rear brakes. After the rear brake starts to take hold, gradually apply the front brake. Since excessive braking pressure will cause the wheel to lock and skid, the rider must use both brakes with moderate pressure to get maximum stopping power without losing control. As the machine continues to slow, shift down through the gears using engine brake to aid the slowing effect. When shifting down, do not over rev the engine.

Use the engine brake when descending long, steep hills. Do not operate the brakes continuously for very long periods. Use at repeated intervals. Special care is required in braking on poor roads and in bad weather. If the front brake is applied too strongly in such conditions the wheel

may lock and cause a fall. At high speeds the front and rear brakes must be applied with balanced force; apply the brakes repeatedly with moderate force and avoid sudden application. Practice the above procedures for safe braking at all times.

NOTE: _____

When using engine braking for long periods, it is very important not to over rev the engine. It is also necessary to open the throttle occasionally because the engine relies on the fuel for internal cooling.



Shifting and acceleration

This model has a 5-speed transmission. The transmission allows you to control the amount of power you have available at a given speed or starting accelerating, climbing hills, etc.

The use of the change pedal is shown in the illustration.

To shift into NEUTRAL, repeatedly depress the change pedal to the end of its travel (you will feel a stop when you are in FIRST gear), then raise it slightly.

To start out and accelerate, proceed as follows:

1. Pull the clutch lever to disengage the clutch.
2. Shift into FIRST.
3. Open the throttle gradually, and at the same time, release the clutch lever slowly.

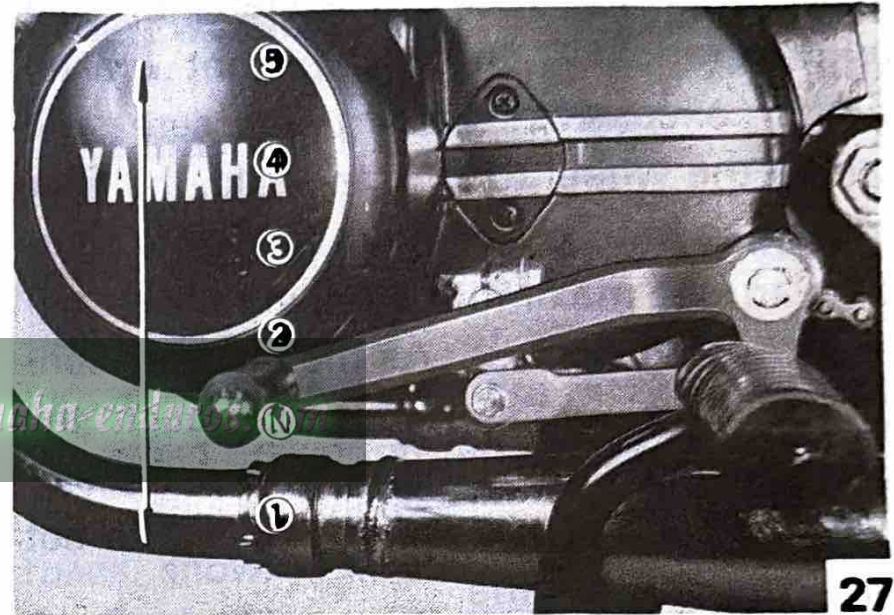

- | | | |
|-----------|-----------|------------|
| 1. FIRST | 3. THIRD | 5. FIFTH |
| 2. SECOND | 4. FOURTH | N. NEUTRAL |

4. At 10 ~ 15 mi/h (15 ~ 25 km/h), close the throttle, and at the same time, pull in the clutch lever quickly.
5. Shift into SECOND; be careful not to shift into NEUTRAL.
6. Open the throttle part way and gradually release the clutch lever.
7. To accelerate or decelerate, use the same procedure to shift into next higher or next lower gear.
8. Use the transmission to keep engine speed in its ideal r.p.m. range.

Ideal r.p.m. range: 1,150 ~ 1,250

Cruising

A frequently asked question is "What r.p.m. should I cruise at?". The BREAK-IN section provides limitations when the motorcycle is new but once the engine has been broken in, then we suggest that you follow these guide lines. For sustained load and throttle conditions, such as those encountered on open highways, cruise at 3/4 throttle or at 3/4 of the r.p.m. "red line", whichever comes first. Always bear in mind, though, the maximum allowable speed limit for the area through which you are riding. This is a recommendation, not a "hard and fast" rule. Any modification or personalization of the running gear could possibly change the operating range most comfortable and most efficient for the engine.

Driving on poor roads

When going from a paved road to an unpaved area, lower the engine speed and drive ahead at reduced speed.

Driving in rain

Roads become slippery in rainy weather and are very dangerous; therefore, always maintain the proper tire pressure, operate at reduced speed and never apply the brakes or throttle suddenly.

Driving on hilly roads

When driving uphill, shift to a lower gear and reduce speed unless the hill can be climbed in the same gear.

When driving downhill, use the same gear as for climbing the hill and always use engine braking. It can be dangerous to shift gears in the middle of a hill. Brakes can be used when necessary but be careful not to

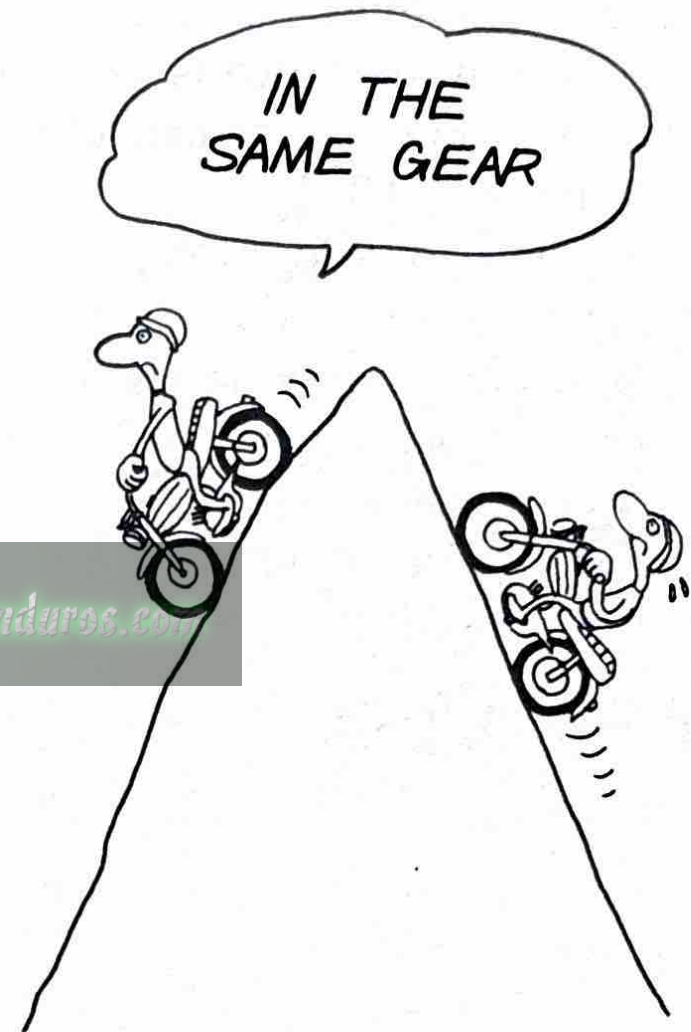

apply the front brake too suddenly as a fall may result.

When stopped in the middle of ascending a hill, re-starting requires some skill. Take the following precautions:

1. Apply the front brake and support the motorcycle with your right leg.
2. Pull the clutch lever and shift into low gear.
3. While still gripping the clutch lever, shift the weight to the left leg and step on the brake pedal with the right foot.
4. While opening the throttle grip, gradually release the clutch lever while releasing the brake and move forward.

Conrrnering

Reduce speed before entering the curve and proceed slowly. Be careful when applying the brakes with the motorcycle leaned into a corner as it may slip.

Break-in

There is never a more important period, in the life of your motorcycle, than the period between zero and 500 miles (800km). For this reason we ask you to carefully read the following material.

Because the engine is brand new, you must not put an excessive load on it for the first several hours of running. During the first 500 miles the various parts in the engine wear and polish themselves to the correct operation, or any condition which might result in excessive heat of cylinder, must be avoided. However, momentary full throttle operation, under load (2-3 seconds maximum), does not harm the engine. Each full throttle acceleration sequence should be followed with a substantial rest period for the engine by cruising at lower r.p.m.'s so the engine can rid itself of the temporary build-up of heat.

If any abnormality is noticed during this

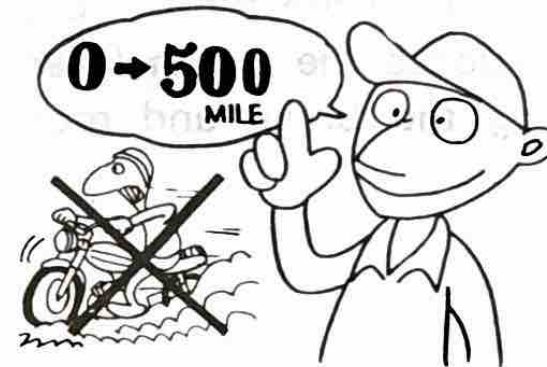

period, ask your Yamaha dealer to check.

1. 0 ~ 100 miles (0 ~ 160 km)
Avoid operation above 4,000 r.p.m..
Allow a cooling off period of 5 to 10 minutes after every hour of operation.
2. 100 ~ 250 miles (160 ~ 400km)
Avoid prolonged operation above 5,000 r.p.m.
Allow the motorcycle to rev freely through the gears but do not use full throttle at any time.
3. 250 ~ 500 miles (400 ~ 800km)
Avoid prolonged full throttle operation.
Avoid cruising speeds in excess of 6,000 r.p.m.
4. 500 miles (800km) and beyond
Avoid prolonged full throttle operation.
Avoid cruising speeds in excess of 7,000 r.p.m.
Vary speeds occasionally.

NOTE: _____

Please read your Owner's Warranty Guide Book thoroughly. It explains your obligation during the break-in period.

Parking

When parking, stop the engine and remove the ignition key.

Make it a habit to turn the fuel petcock to "STOP" whenever stopping the engine.

NOTE: _____

Select a parking place where the motorcycle is not apt to fall.

PERIODIC MAINTENANCE AND MINOR REPAIR

Tool kit

The tools provided in the owner's tool kit are sufficient for periodic maintenance and minor repair purpose, except that a torque wrench is also necessary to properly tighten nuts and bolts.

Should you desire additional service information on this model a copy of Service Manual can be purchased from any Authorized Yamaha Dealer.

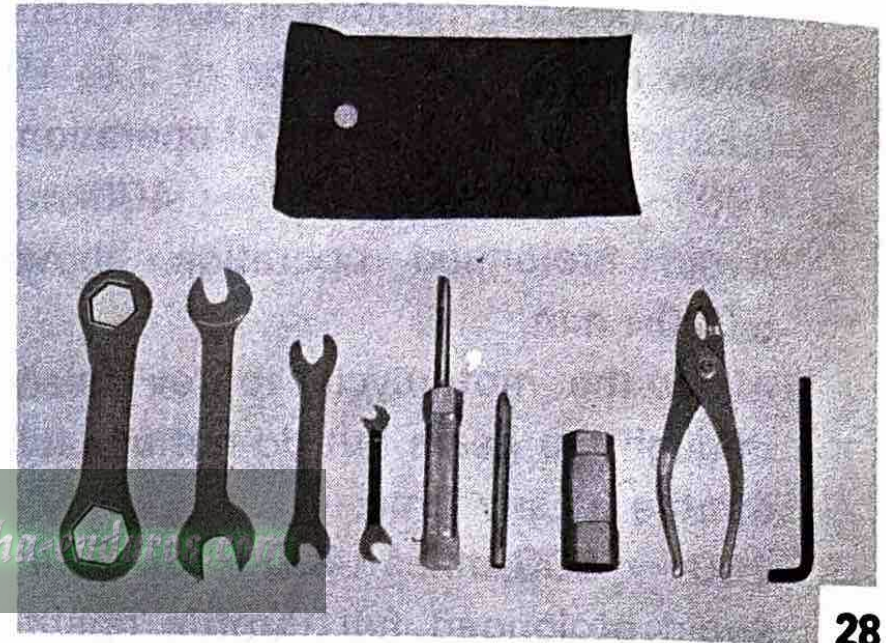

28

CAUTION

The following sections provide information for the disassembly, troubleshooting and maintenance of various components of the motorcycle. If you do not have the necessary tools and an understanding of the mechanical principles involved, please refrain from attempting repairs. The use of improper tools and/or procedures can cause major damage to the unit with resultant additional repair costs.

www.legends-yamaha-enduro.com

Periodic maintenance

Periodic inspection, adjustment and lubrication will keep your motorcycle in the safest and most efficient condition.

Safety is an obligation of the motorcycle owner.

The most important points of motorcycle inspection, adjustment and lubrication are explained below; if the owner is not familiar with motorcycle service, this work should be done by a Yamaha dealer.

Lubrication Intervals

| Page | Item | Remarks | Type | Initial (mile) | | | | Thereafter every (mile) | | |
|--------|---------------------------------|--------------------------------|-------|---------------------|-----|------|------|-------------------------|------|------|
| | | | | 250 | 500 | 1000 | 2000 | 1000 | 2000 | 4000 |
| 39 | Autolube | See "Service Notes" | No. 1 | See "Service Notes" | | | | | | |
| 44, 45 | Transmission oil change | Warm engine before draining | No. 2 | CHK | ○ | ○ | | CHK | ○ | |
| 63~66 | Drive chain | Lubrication/Adjust as required | No. 3 | See "Service Notes" | | | | | | |
| 63~66 | Drive chain | Remove/Clean/Lube/Adjust | No. 3 | | | ○ | | ○ | | |
| 48 | Air filter | Foam type | No.11 | See "Service Notes" | | | | | | |
| 66 | Control and meter cables | All-apply thoroughly | No. 4 | | | ○ | ○ | | ○ | |
| 67 | Throttle grip and housing | Light application | No. 5 | | | | ○ | | ○ | |
| Dealer | Tacho/Speedometer gear housings | Light application | No. 5 | | | | ○ | | | ○ |
| — | Rear arm pivot shaft | Zerk-apply until shows | No. 6 | | | ○ | | ○ | | |
| — | Brake pedal shaft | Light application | No. 5 | | | ○ | | | ○ | |
| — | Change pedal shaft | Light application | No. 5 | | | ○ | | | ○ | |
| — | Stand shaft pivot(s) | Light application | No. 5 | | | ○ | | | ○ | |
| Dealer | Front forks | Drain completely | No. 9 | | CHK | | ○ | CHK | ○ | |
| Dealer | Steering ball races | Inspect thoroughly/Pack | No. 7 | | | | ○ | | CHK | ○ |
| Dealer | Point cam lubrication wick | Very light application | No. 8 | | | ○ | | | | ○ |
| Dealer | Hyd. brake fluid res. | Use new fluid only | No.10 | CHK | | CHK | | CHK | | 8000 |
| Dealer | Wheel bearings | Do not over-pack | No. 7 | | | | ○ | CHK | ○ | |

* Be sure to check the above points before long-distance touring.

Recommended Lubricants

- No. 1 Check tank level before each ride. Top off when oil level is at sight glass or before any prolonged use. Use the following lubricant (in order of preference):
Yamalube "2-cycle" or two-stroke oil labeled "BIA certified for service TC-W".
- No. 2 Use Yamalube 4-cycle oil, or SAE 20W/40 type "SE" motor oil.
- No. 3 Use SAE 10W/30 type "SE" motor oil. (If desired, speciality lubricants of quality manufacture may be used.)
- No. 4 Use SAE 10W/30 type "SE" motor oil. (If desired, or at ambient temperatures below 30°F., a graphite base "dry" lubricant of quality manufacture may be used.)
- No. 5 Light duty: Lithium soap base grease.
Heavy duty: Standard chassis lube grease. (Do not use chassis lube grease on throttle/throttle housing.)
- No. 6 Use a soft chassis lube grease (soft fiber).
- No. 7 Medium-weight wheel bearing grease of quality manufacture—preferably waterproof.
- No. 8 Light-weight machine oil.
- No. 9 Use Yamaha fork oil.

- No. 10 Change yearly or every 8,000 miles (12,800 km). Use quality manufacture corresponding to DOT#3 or #4 specifications.
Keep clean. Do not allow water, etc., to contaminate.
Do not mix types when adding.
- No. 11 Air filters—Foam element air filters must be damp with oil at all times to function properly. Clean and lube monthly or per mileage.
If hard usage, clean and lube daily. Do not overoil. Use SAE 10W/30"SE".

Periodic Maintenance Intervals

| Page | Item | Remarks <i>www.legends-gambaha-enduros.com</i> | Initial (mile) | | | | Thereafter every (mile) | |
|--------|-------------------------|---|----------------|-----|------|------|-------------------------|------|
| | | | 250 | 500 | 1000 | 2000 | 1000 | 2000 |
| 59~62 | Brake system (complete) | Check/Adjust as required - repair as required | ○ | ○ | ○ | | ○ | |
| 57, 58 | Clutch | Check/Adjust as required | ○ | ○ | ○ | | ○ | |
| 58, 59 | Battery | Top-off/Check specification gravity monthly | ○ | | ○ | | ○ | |
| 46, 47 | Spark plug(s) | Inspect/Clean or replace as required | ○ | ○ | ○ | | ○ | |
| Dealer | Wheels and tires | Pressure/Spoke - tension/Runout | ○ | ○ | ○ | | ○ | |
| — | Fittings and fasteners | Tighten before each trip | ○ | ○ | ○ | | ○ | |
| 63~65 | Drive chain | Tension/Alignment No. 1 | ○ | ○ | ○ | | ○ | |
| 48, 49 | Air filter | Wet type - clean/Replace as required No. 2 | | | ○ | ○ | ○ | |
| 56, 57 | Fuel petcock(s) | Clean/Flush tank as required | ○ | | ○ | | ○ | |

| Page | Item | Remarks | Initial (mile) | | | | Thereafter every (mile) | |
|--------|------------------------|---|----------------|-----|------|------|-------------------------|------|
| | | | 250 | 500 | 1000 | 2000 | 1000 | 2000 |
| Dealer | Ignition timing | Adjust/Clean or replace parts as required | | ○ | ○ | ○ | | ○ |
| 50~54 | Carburetor adjustment | Check operation/Timings | | ○ | ○ | ○ | | ○ |
| Dealer | Carburetor overhaul | Clean/Repair as required/Refit/Adjust | | | | | | 4000 |
| Dealer | Engine decarbonization | Includes exhaust system | | | ○ | | | ○ |

SERVICE NOTES:

- No. 1 Check Autolube tank level before each ride. Top off when oil level shows at the sight glass or before any prolonged use. See "Lubrication intervals" for type of oil to use.
- No. 2 **DRIVE CHAIN:** In addition to tension and alignment, chain must be lubricated every 200 ~ 250 miles (320 ~ 400 km). If unit is subjected to extremely hard usage and wet weather riding, chain must be checked constantly. See "Lubrication intervals" for additional details.
- No. 3 **AIR FILTER:** Foam element air filters must be damp with oil at all times to function properly. Remove, clean, and oil filter at least once per month or every 250 ~ 500 miles (400 ~ 800 km): whichever occurs first. (If extremely hard usage, such as dirt riding, clean and lube daily.) See "Lubrication intervals" for additional details.

Torque specification

This list below covers those stud bolt sizes with standard I.S.O. pitch threads. Torque specifications for components with thread pitches other than standard are given within the applicable chapter.

Torque specifications call for dry, clean threads. Components such as the cylinder or cylinder head should be at room temperature prior to torquing. A cylinder head or any other item with several fasteners should be torqued down in a crisscross pattern in successive stages until torque specification is reached. The method is similar to installing an automobile wheel and will avoid warping the component.

| A (NUT) | B (BOLT) | TORQUE SPECIFICATION | | |
|------------|-------------|----------------------|---------|-----------|
| | | m-kg | ft-lb | in-lb |
| 10 mm | 6 mm | 1.0 | 7.2 | 85 |
| 12 mm | 8 mm | 2.0 | 15 | 175 |
| 14 mm | 10 mm | 3.5 ~ 4.0 | 25 ~ 29 | 300 ~ 350 |
| 17 mm | 12 mm | 4.0 ~ 4.5 | 29 ~ 33 | 350 ~ 400 |
| 19 mm | 14 mm | 4.5 ~ 5.0 | 33 ~ 36 | 400 ~ 440 |
| 22 mm | 16 mm | 5.5 ~ 6.5 | 41 ~ 49 | 480 ~ 570 |
| 24 mm | 18 mm | 5.8 ~ 7.0 | 42 ~ 50 | 504 ~ 600 |
| 27 mm | 20 mm | 7.0 ~ 8.3 | 50 ~ 60 | 600 ~ 700 |

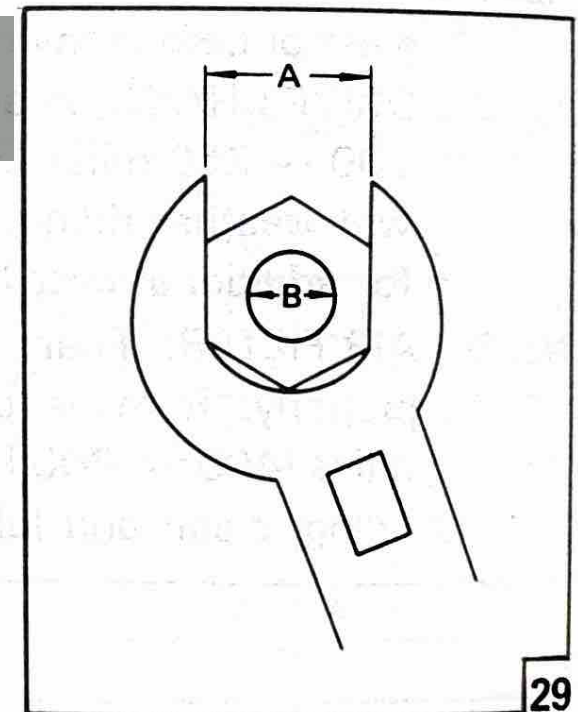

Engine oil

Use the engine oils in the following list. We recommend Yamalube 2-cycle oil (available at most Yamaha dealers) but, if other oils are used, select from the following list which is given in order of preference.

1. 2-stroke engine oil labeled "BIA certified for service TC-W".
2. SAE 30 weight, detergent type automobile engine oil with an "SE" rating. This last oil should be used only as an emergency measure when 2-stroke oils are not available.

NOTE: _____

Oil viscosity increases in very cold weather (where the normal temperature is below 0°C, 32°F) and oil does not circulate as well. In such areas, consult your Yamaha dealer.

Oil tank capacity: 2.1 U.S. qt (2.0 lit)



1. Refill if level shows

30

Transmission oil

The only servicing for you to do is to check and fill the transmission lubricating oil. The transmission dip stick is located right above the kickstarter. To check the level, warm the engine up for several minutes, screw the dip stick completely out and then just rest the stick in the hole.

NOTE: _____

When checking transmission oil level with the dip stick, let the unscrewed dip stick just rest on the case threads. Also, be sure the machine is positioned straight up and on both wheels.

Recommended oil:

Yamalube 4-cycle oil or SAE 20W/40
Motor oil, Type "SE"

Amount:

0.79±0.05 U.S. qt (750±50 cc)

The dip stick has a Minimum and a Maximum mark, and the oil level should be between the two. If the level is lower, then add sufficient oil to raise it to the proper level.

During the break-in period, you should replace the gear oil 30 days after the date of purchase or thereafter 2,000 miles (3,200km). The transmission should be drained and refilled approximately every 2,000 miles. On the bottom of the engine there is a drain plug.

Remove it and drain all the transmission oil out.

Reinstall the drain plug (make sure it is tight). Add oil through the dip stick hole.

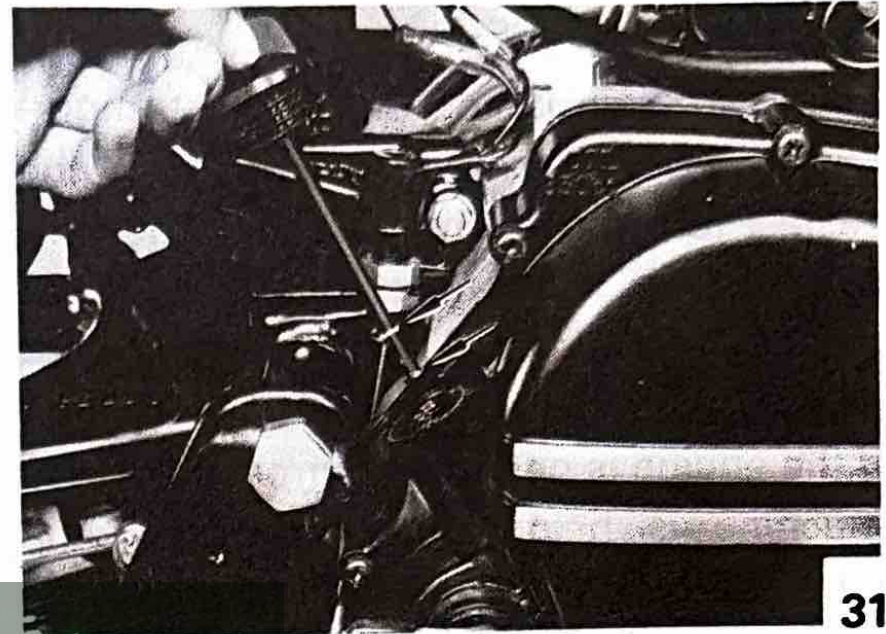

31

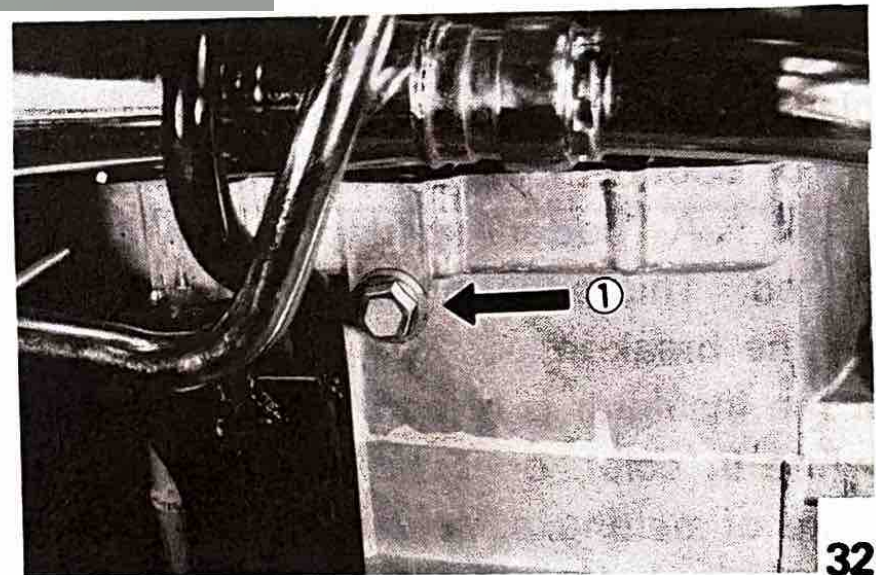

32

1.. Drain plug

Spark plug inspection

The spark plug is one of the most important of the engine components and is the easiest to inspect. By examining the condition of the spark plug we can, to some extent, determine the condition of the engine.

If the engine is operating correctly, and the machine is being ridden correctly, the white porcelain insulator around the center electrode will be a medium to light tan color.

If the porcelain is a very dark brown or black color and the firing end is wet with oil or sooty, the spark plug may be too "cold". A "hotter" spark plug may be required. This situation is common during engine break-in

If the insulator is glazed and very light or white in color, or if the electrodes show signs of melting, a "colder" spark plug may be required. If spark plug appearance indi-

cates a performance problem, ask a Yamaha dealer to investigate the situation. Do not change the spark plug type without consulting with your dealer. You should, however, periodically remove and inspect the spark plug because heat and deposits will cause any spark plug to slowly breakdown and erode. If electrode erosion becomes excessive, or if carbon and other deposits are excessive, you should replace the spark plug with one of the proper types.

Standard spark plug: NGK B-8ES

NOTE: _____
Spark plugs are produced in several different thread lengths. The thread length (reach) is the distance from the spark plug gasket seat to the end of the threaded portion. If the reach is too long, overheating and engine damage may result.

If the reach is too short, spark plug fouling and poor performance may result; also, carbon will form on the exposed threads resulting in combustion chamber hot spots and thread damage. Always use a spark plug with the proper reach.

Spark plug reach:

3/4 in (19.0 mm)

Before installing any spark plug, measure the electrode gap with a wire thickness gauge and adjust to specification.

Spark plug gap:

0.024 ~ 0.028 in (0.6 ~ 0.7 mm)

When installing the plug, always clean the gasket surface and use a new gasket. Wipe off any grime from the threads and

torque the spark plug properly.

Spark plug torque:

230 ~ 250 in-lb (2.7 ~ 2.9 m-k)

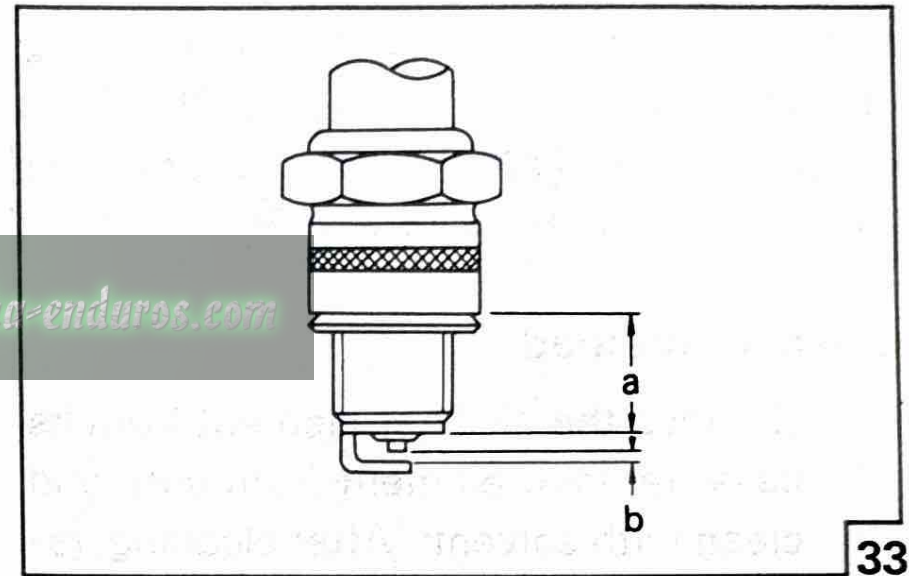

a: Reach, 3/4 in (19.0 mm)

b: Gap, 0.024 to 0.028 in
(0.6 to 0.7 mm)

Cleaning the air filter element

The air filter protects the engine from dirt which can enter with the intake air and cause rapid engine wear. This dirt is filtered from the air by the air filter element. This model uses a cartridge type air filter element which consists of foam rubber moistened with oil. When this filter element becomes dirty it should be cleaned with solvent and reoiled.

Cleaning method

1. Remove the air filter element from its case, remove element from core and clean with solvent. After cleaning, remove the remaining solvent by squeezing the foam rubber.

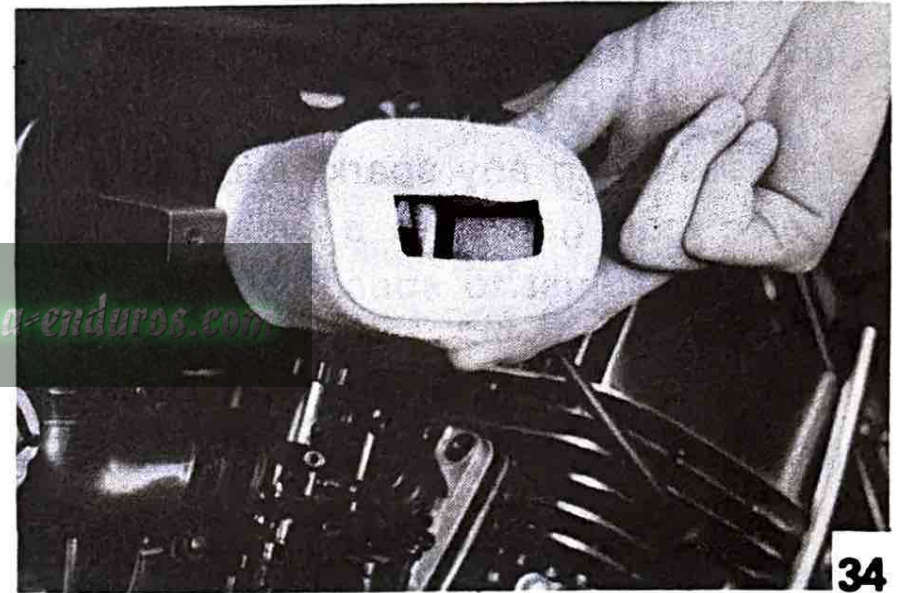

2. Then apply 30wt motor oil to the entire surface and squeeze out the excess oil. Foam should be wet but not dripping. (Fig. 35)
3. When installing the air filter element in its case, be sure its sealing surface matches perfectly the sealing surface of the case so there is no air leakage.
4. The air filter element should be cleaned once a month or every 1,000 miles (1600 km). It should be cleaned every ten hours or more often if the machine is operated in extremely dusty areas.



35

NOTE: _____

The engine should never be run without the air cleaner element installed- overheating and piston damage may result.

Carburetor adjustment

The carburetor is a vital part of the engine and requires very sophisticated adjustment. Most adjusting should be left to a Yamaha dealer who has the professional knowledge and experience to do so.

However, the following three points may be serviced by the owner as part of his usual maintenance routine.

1. Idle mixture adjustment
2. Idling speed adjustment
3. Throttle cable play adjustment

NOTE: _____

The carburetor was set at the Yamaha factory after many tests. If the settings are disturbed without having technical knowledge, poor engine performance and damage may result.

Idle mixture adjustment

The idle mixture adjustment controls the amount of mixture to the engine at low r.p.m. The mixture also insures smooth transition to the main circuit with no power loss or misfire- so it does affect mi-drage performance.

Make this adjustment as described below. Tighten the pilot air screw until it lightly touches the seat, then back the screw out the specified number of turns.

This should be done with the engine stopped. Be sure to back out the same number of turns for both the right and left carburetors.

Pilot air screw setting: 1-1/2
(Number of turns out)

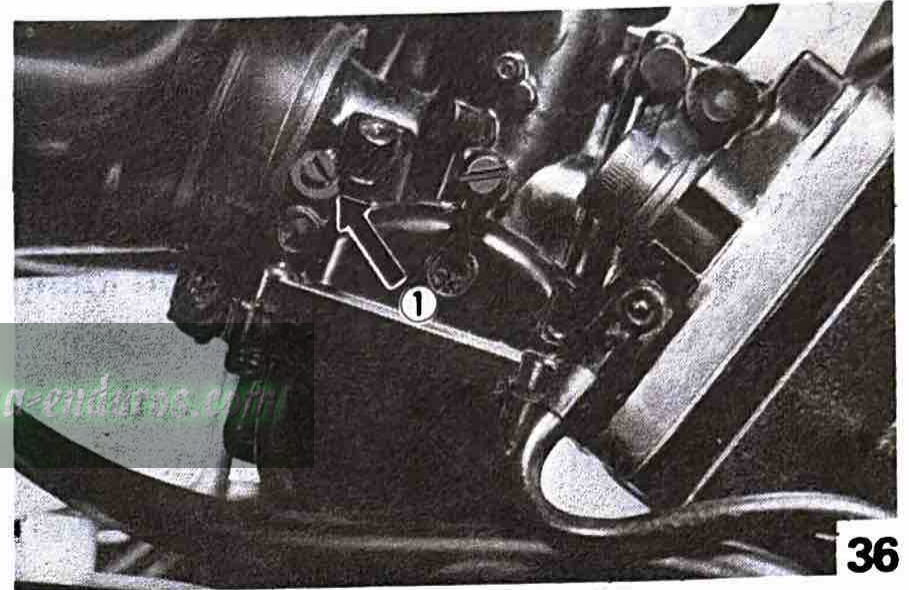

1. Pilot air screw

Idling r.p.m. adjustment

Start the engine and warm it up for a few minutes. The warm up is complete when the engine responds quickly without dying. Normally 1 to 2 minutes is required; 2 to 3 minutes in cold weather.

Turning the throttle stop screw counterclockwise lowers the engine speed. One clockwise turn from the engine stall position is considered to be the specified idling position.

As a check, run the engine with the lighting switch at "ON" position. If the engine r.p.m. steady and not excessively high, idling speed is correct.

Idling speed: 1,150 ~ 1,250 rpm

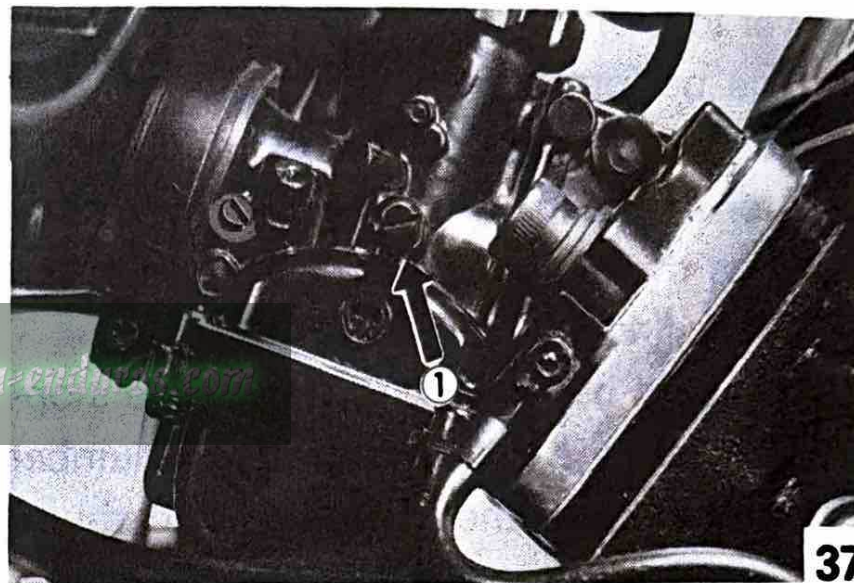

1. Throttle stop screw

Carburetor inspection

In addition to the above adjustment, check the following periodically:

1. Are the carburetor holding bolts tight?
2. Is the air vent pipe in the correct position?
3. Is the overflow pipe connected properly?
4. Is the mixing chamber top tight?
5. Is the starter connecting pipe in position?

www.legends-yamaha-enduros.com

Inspection and adjustment of play in throttle cable 2

A throttle cable should always have a little play in it. If too tight, a sharp turn may cause the engine speed to increase. On the other hand, if the throttle valve does not open fully when the throttle grip is turned fully, full speed is not possible. Adjust as described below.

NOTE: _____

Before adjusting the play in throttle cable 2, adjust the engine idling speed and make sure the mixing chamber top is tight.

1. Move the rubber cover of the mixing chamber top to expose the cable adjuster.
2. Hold the outer cable near top of carburetor and down to check the play.
3. Loosen locknut and turn the cable adjuster in or out to achieve 0.04 in (1 mm) of play. Be sure to tighten the locknut.

Inspection and adjustment of play in throttle cable 1

The following explains the adjustment of throttle cable 1. (see the illustration)

NOTE: _____

Adjust the play in both throttle cables; if only one is adjusted, trouble may occur.

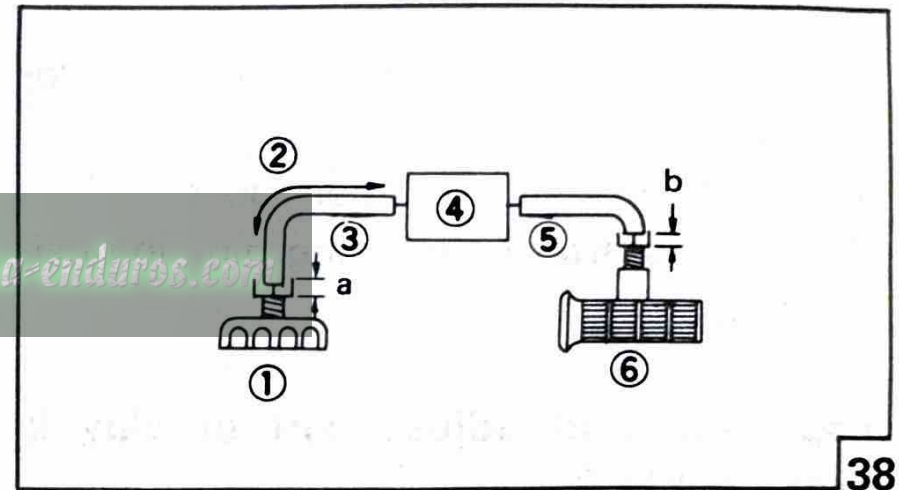

- | | |
|----------------------------------|-------------------|
| a. 0.04 in (1 mm) | 3. Cable 2 |
| b. 0.02 ~ 0.04 in (0.5 ~ 1.0 mm) | 4. Junction block |
| 1. Carburetor cap | 5. Cable 1 |
| 2. Slide | 6. Throttle grip |

Check the outer cable play at the cable guide of the throttle grip assembly. The play should be 0.02 ~ 0.04 in (0.5 ~ 1.0 mm), loosen the locknut and turn the cable adjuster to make the necessary adjustment. After adjusting, be sure to tighten the locknut properly.

Autolube pump cable adjustment

Close the throttle grip completely, then twist it open until all cable slack is removed, but stop before the slides start to lift. Adjust the ppmp cable so the mark on the pump pulley lines up with the "adjust pulley guide pin". The Autolube cable adjuster is located at the bottom end of the cable, screwed into the top of the right case cover.

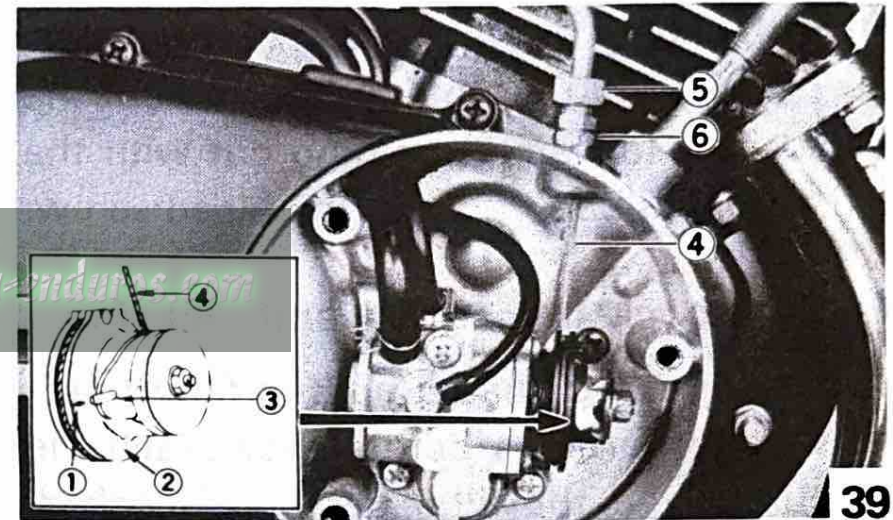

- | | |
|------------------|---------------------|
| 1. Mark (▷) | 4. Pump cable |
| 2. Adjust pulley | 5. Adjuster |
| 3. Pin | 6. Adjuster locknut |

Bleeding the Autolube pump

If the pump runs out of oil, the pump must be bled to release air trapped in the pump. Remove the Phillips head bleed screw, twist the throttle to full open position (turns the Autolube pump to maximum stroke), and rotate the plastic manual starter pump plate until only oil comes out the bleed hole (air stops coming out with the oil). Reinstall and tighten the bleed screw.

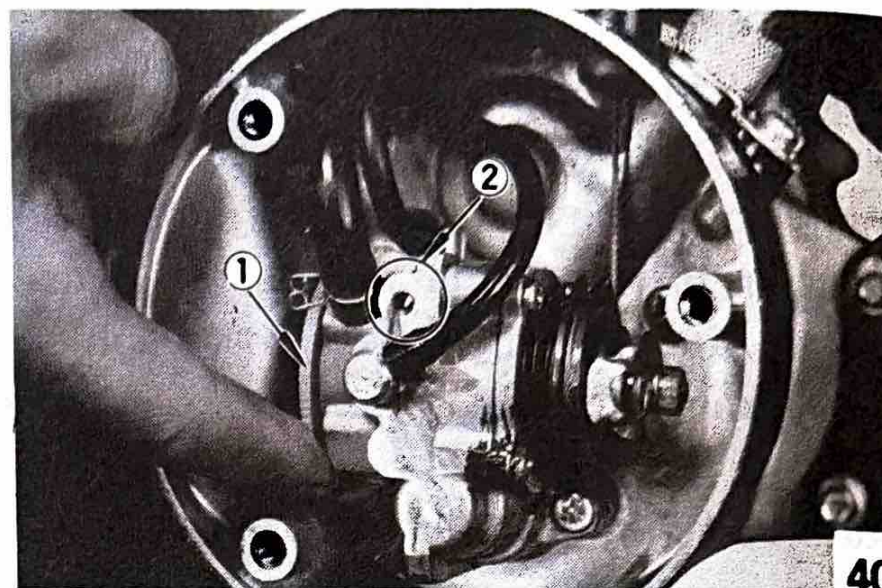

1. Starter plate

2. Bleed hole

Fuel petcock inspection and cleaning

The fuel petcock has a built-in filter to remove any particles before they reach the carburetor. If the filter becomes blocked, the fuel cannot enter the carburetor. To prevent this, inspection and cleaning should be done at recommended intervals. First, turn the petcock lever to the "OFF" position; then remove the filter cup and clean the bottom of the cup with solvent.

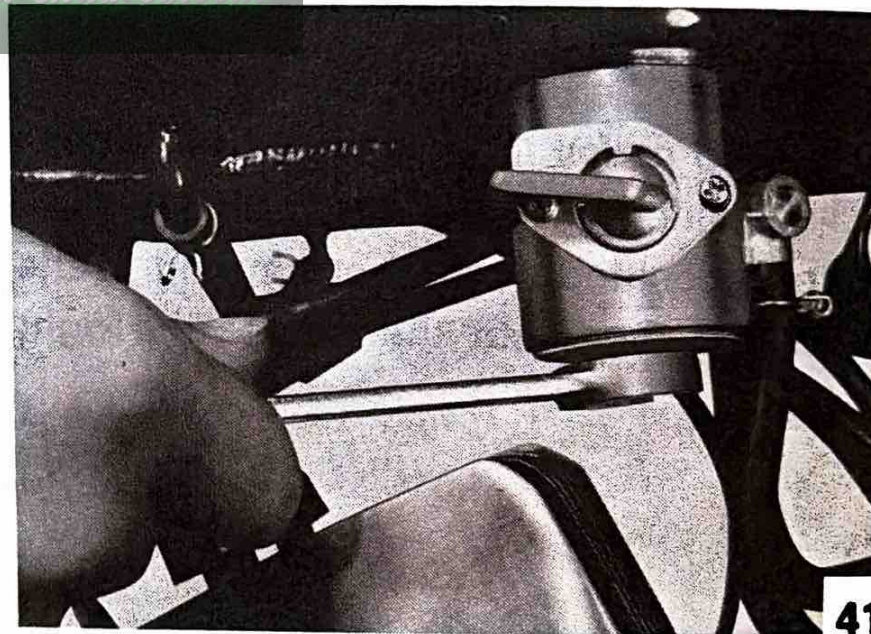

After removing the filter cup, remove and clean the filter screen. (Fig. 42)

At the same time, you should examine the condition of the filter gasket. Replace if damaged.

When reassembling, be careful not to clamp the filter cup too tightly as this may cause the filter gasket to become unseated resulting in fuel leakage.

Clutch adjustment

There are two different clutch adjustments; (1) adjusting the play at the clutch lever, and (2) adjusting the play in the clutch push screw. Adjusting the play at the lever is usually sufficient; adjusting the play in the push screw should be left to the dealer.

Loosen the locknut and make the necessary adjustment by turning the adjuster until the clearance between the front of

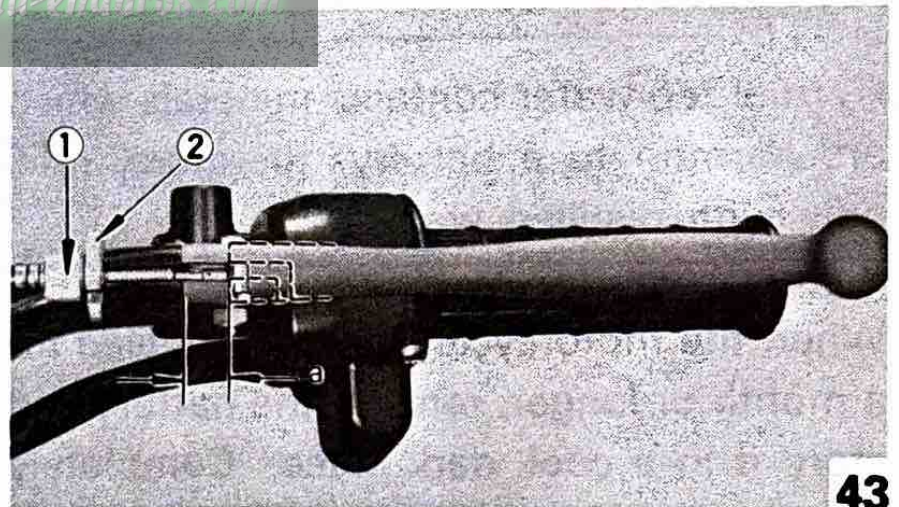

a. 1/16 ~ 1/8 in (2 ~ 3 mm)

1. Adjuster

2. Adjuster locknut

the clutch lever and the lever holder is between $1/16 \sim 1/8$ in ($2 \sim 3$ mm), and tighten the locknut.

Replenishing the battery fluid

A poorly maintained battery will deteriorate quickly. The battery fluid should be checked at least once a month.

The level should be between the High and Low level marks. Use only distilled water if refilling is necessary.

NOTE:

Normal tap water contains minerals which are harmful to a battery; therefore, refill only with distilled water.

When the motorcycle is not to be used for a month or longer, remove the battery and store it in a cool, dark place. Completely recharge the battery before reusing.

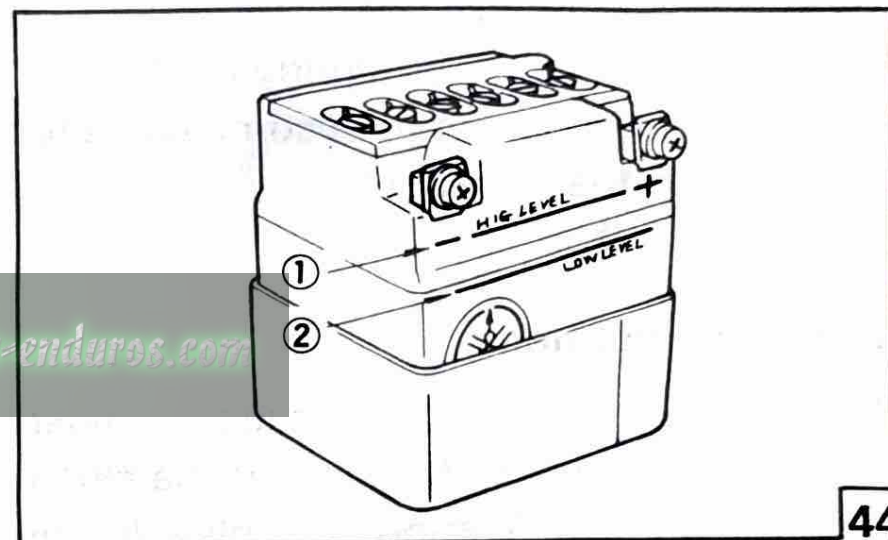

1. High level

2. Low level

44

If the battery is to be stored for a longer period than the above, check the specific gravity of the fluid at least once a month and recharge the battery when it is too low.

Always make sure the connections are correct when putting the battery back in the motorcycle. The red lead is for the + terminal and the black lead is for the - terminal. Make sure the breather pipe is properly connected and is not damaged or obstructed.

Front brake adjustment

The front brake lever should be adjusted so that it has a free play of 0.5 ~ 1.0 in (13 ~ 26 mm) from when the brake lever is pulled to when the brake begins to be effected.

1. Loosen the adjusting screw locknut.
2. By turning in and out the adjusting screw, adjust the play of brake lever and then lock it with locknut.

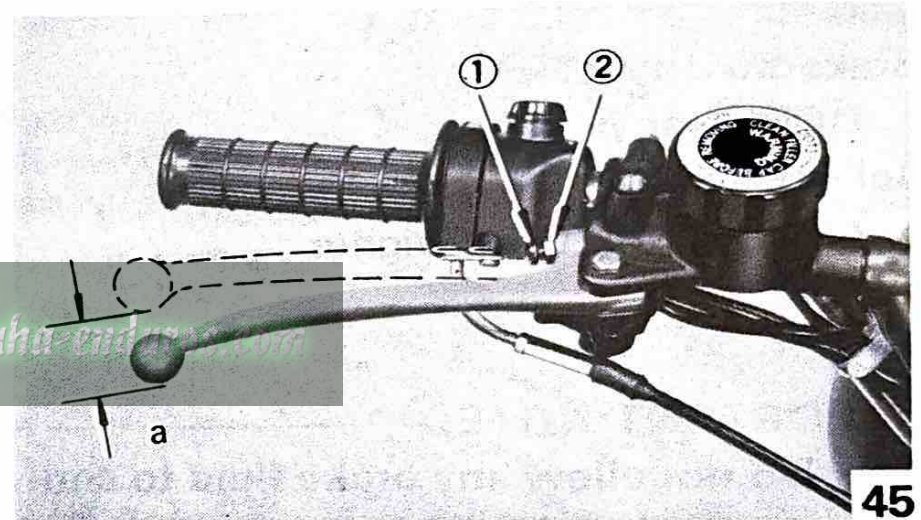

a. 0.5 ~ 1.0 in (13 ~ 26 mm)

1. Adjusting screw

2. Locknut

Checking the front brake fluid

If the brake fluid level becomes low, brake failures will occur.

Check the master cylinder fluid level. If it is found below the specified level, add the fluid.

Brake fluid type:

DOT#3 or #4

Boiling point:

464°F (240°C) or higher

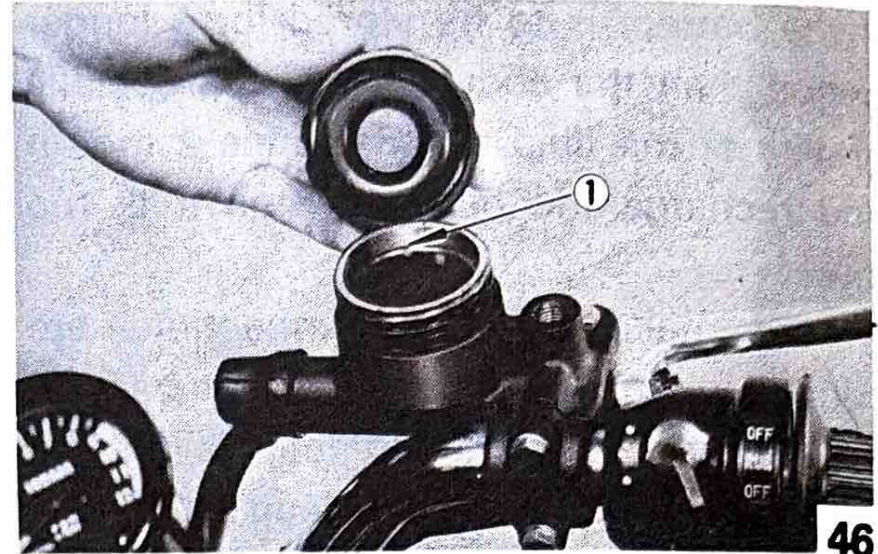

1. Fluid low level

www.legends-yamaha-enduros.com

IMPORTANT NOTE:

1. Do not allow any brake fluid to contact painted surfaces, plastic parts or rubber parts or they will be damaged.
2. If the brake fluid level decreases rapidly, have your Yamaha dealer check the brake immediately.
3. Avoid using any brake fluids other than those meeting specifications.
4. Avoid mixing the brake fluid with other makes. Chemical reactions may occur, causing brake troubles.

Rear brake adjustment

The rear brake should be adjusted so the end of the brake pedal moves 0.8 ~ 1.1 in (20 ~ 30 mm). To adjust, turn the adjusting nut on the brake rod clockwise to reduce play; turn the nut counterclockwise to increase play. Check whether or not the stop light operates correctly after adjusting.

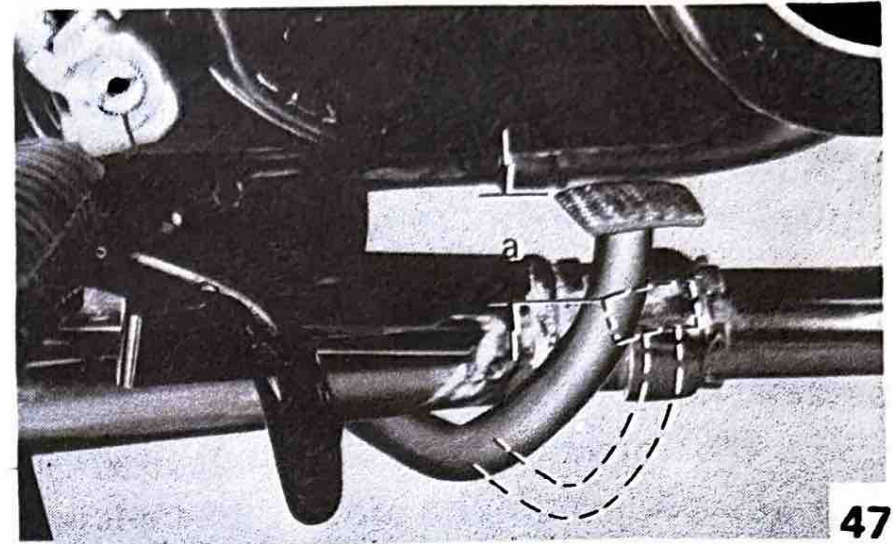

a. 0.8 ~ 1.1 in (20 ~ 30 mm)

www.legends-yamaha-motor.com

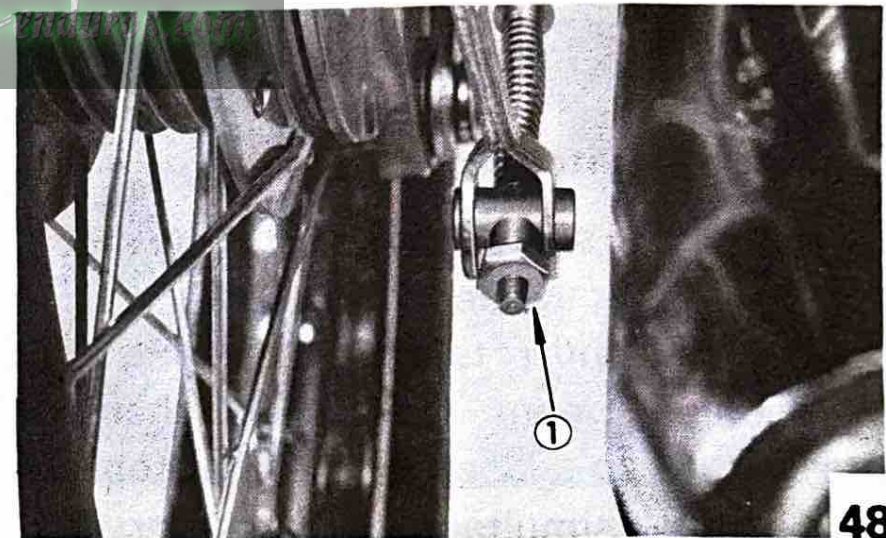

1. Adjusting nut

Brake lining inspection

The specified thickness of the brake lining is 0.157 in (4 mm). The lining should be replaced when it wears to less than 0.079 in (2 mm).

To inspect, remove the plug from the inspection hole on the brake shoe plate and check the thickness of the lining. If worn out, ask your Yamaha dealer to install a new set. Be sure to replace the plug carefully so water cannot enter the shoe plate.

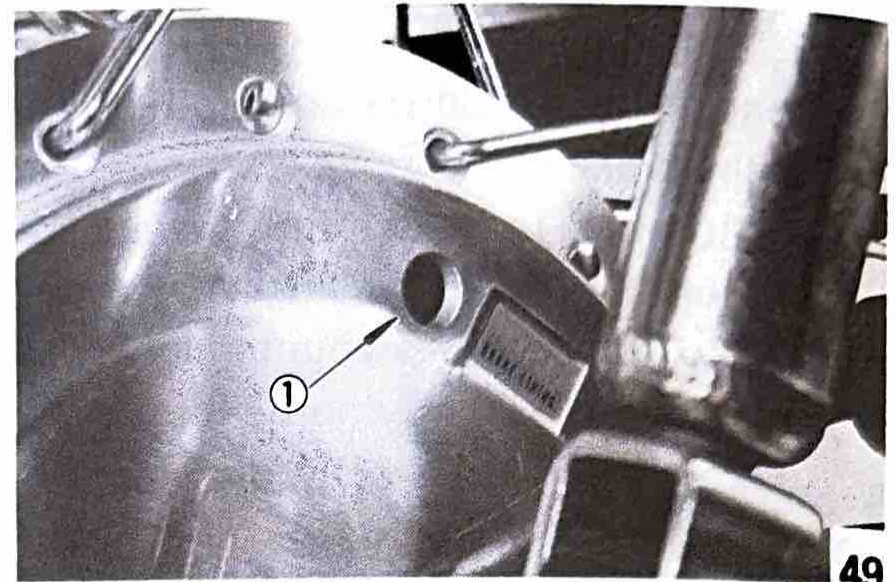

1. Inspection hole (Rear brake)

49

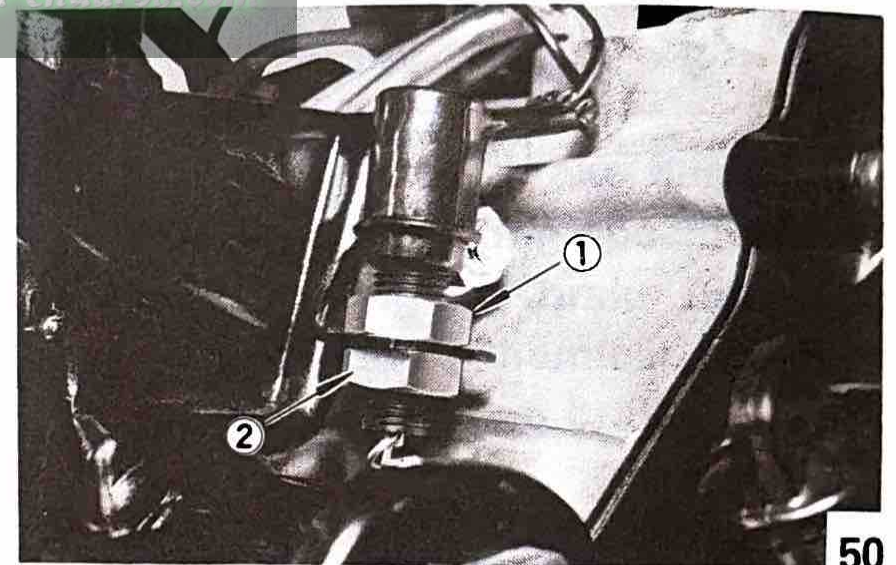

1. Adjusting nut

2. Locknut

50

Stoplight switch adjustment

The stoplight switch is operated by movement of the brake pedal. To adjust, loosen the locknut and rotate the adjusting nut. Proper adjustment is achieved when the brake starts to take effect and the stoplight illuminates simultaneously. After adjusting, tighten the locknut.

Drive chain tension check

Inspect the drive chain with both tires touching the ground. Check the tension at the position shown in the illustration.

The normal vertical deflection is approximately $\frac{3}{4}$ in (20 mm). If the deflection exceeds $\frac{3}{4}$ in (20 mm), adjust the chain tension.

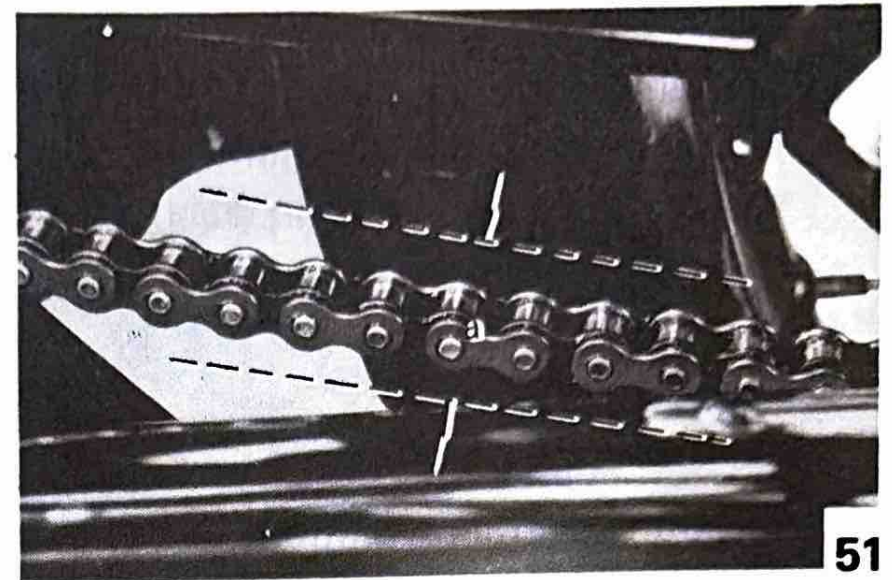

a. $\frac{3}{4}$ in (20 mm)

Drive chain adjustment

1. Loosen the rear brake adjusting nut.
2. Remove the cotter pin of the rear wheel axle nut with pliers.
3. Loosen the rear wheel axle nut and the sprocket shaft nut.
4. Loosen the adjusting bolt locknuts on each side. To tighten chain turn chain puller adjusting bolts clockwise. To loosen chain turn adjusting bolts counterclockwise and push the rear wheel forward.

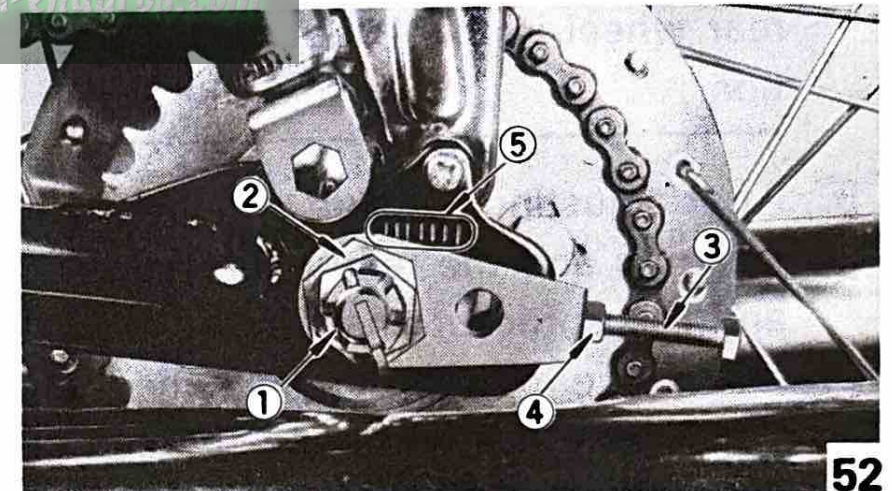

- | | |
|-----------------------|------------------------|
| 1. Axle nut | 4. Locknut |
| 2. Sprocket shaft nut | 5. Marks for alignment |
| 3. Adjusting bolt | |

Turn each bolt exactly the same amount to maintain correct axle alignment. (There are marks on each side of rear arm and on each chain puller; use them to check for proper alignment.)

NOTE: _____

Before adjusting, rotate rear wheel through several revolutions and check tension several times to find the tightest point. Adjust chain tension with rear wheel in this "tight chain" position.

5. After adjusting, be sure to tighten the locknuts and the rear wheel axle nut and the sprocket shaft nut.
6. Insert the cotter pin into the rear wheel axle nut and bend the end of the cotter pin as shown in the illustration. (If the nut notch and the cotter

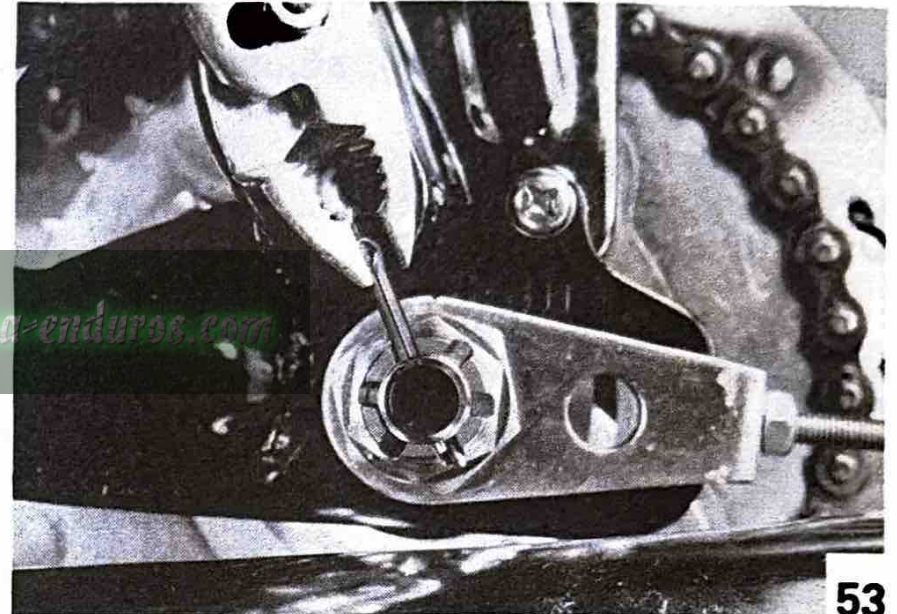

pin hole do not match, tighten the nut slightly to match.) (Fig. 54)

7. In the final step, adjust the play in the brake pedal.

NOTE: _____

Excessive chain tension will overload the engine and other vital parts; keep the tension within the specified limits. Also, replace the rear axle cotter pin with a new one.

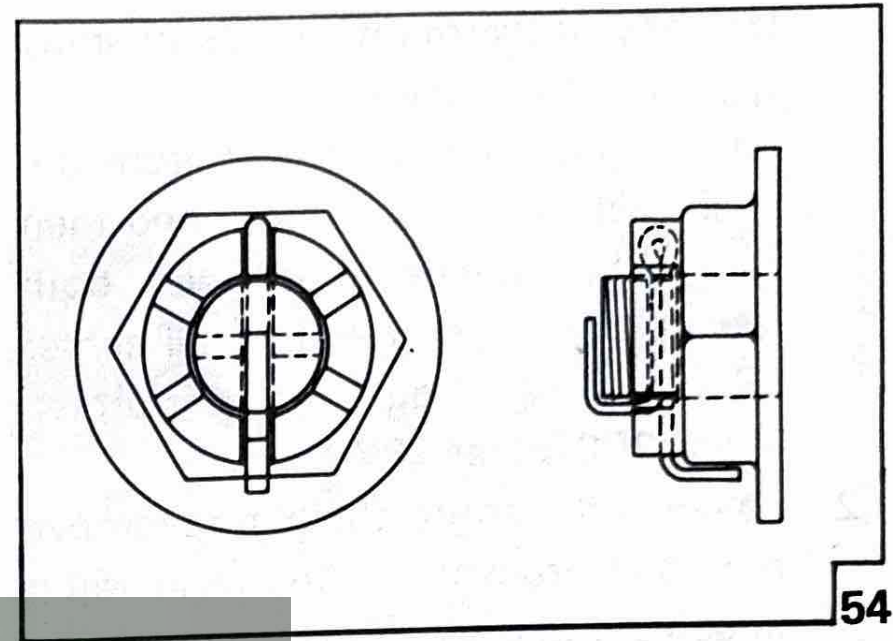

www.legends-yamaha-enduros.com

Drive chain lubrication

The chain consists of many parts which work against each other. If the chain is not maintained properly, it will wear out rapidly. Without lubrication the chain could wear out within 100 miles (160 km); therefore, form the habit of periodically servicing the chain. This service is especially necessary when driving in dusty condition.

1. Use any of the many brands of spray type chain lubricant.

First, remove dirt and mud from the chain with a brush or cloth and then spray the lubricant between both rows of side plates and on all center rollers. This should be performed every 200 miles (320 km).

2. To clean the entire chain, first remove the chain from the motorcycle, dip it in solvent and clean out as much dirt as possible. Then take the chain out of the solvent and dry it. After drying, lubricate the chain to prevent the formation of rust.

Cable inspection and lubrication

1. Damage to the outer housing of the various cables, may cause corrosion and often free movement will be obstructed.

An unsafe condition may result so replace as soon as possible.

2. If the inner cables do not operate smoothly, lubricate or ask your Yamaha dealer to replace them.

Recommended lubricant:

SAE 10W/30 Type "SE" motor oil

Throttle cable and grip lubrication

The throttle twist grip assembly should be greased at the time that the cable is lubricated, since the grip must be removed to get at the end of the throttle cable. Two screws clamp the throttle housing to the handlebar. Once these two are removed, the end of the cable can be held high to pour in several drops of lubricant. With the throttle grip disassembled coat the metal surfaces of the grip assembly with a suitable all-purpose grease to cut down friction. (See lubrication chart)

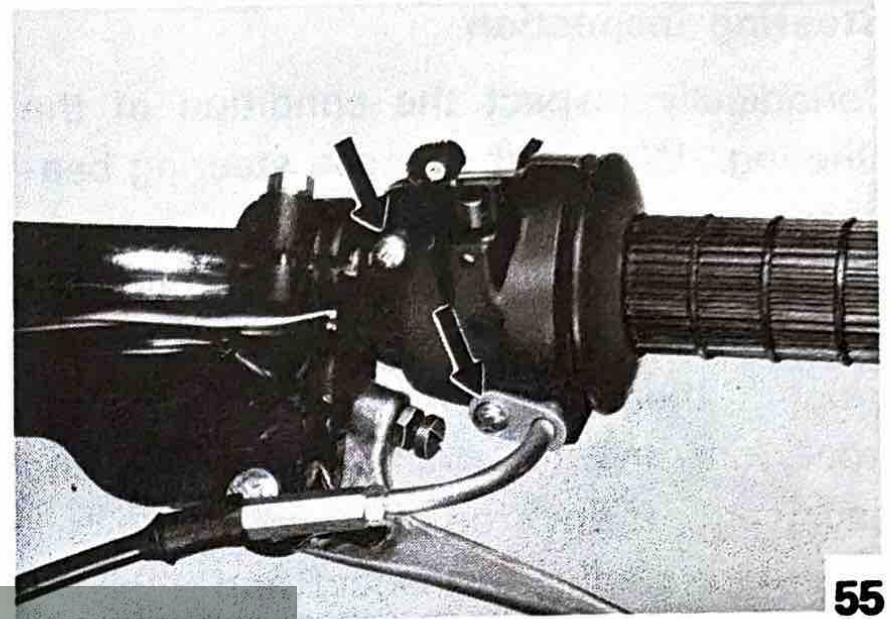

Lubrication of levers, pedals, etc.

1. Lubricate the pivoting parts of the brake and clutch levers with motor oil (10W/30).
2. Lubricate the shaft of the brake pedal with lithium soap grease.

Steering inspection

Periodically inspect the condition of the steering. Worn out or loose steering bearings may be dangerous.

Place a block under the engine to raise the front wheel of the motorcycle off the ground; then hold the lower end of the front fork and try to move forward and backward. If any free play can be felt, ask a Yamaha dealer to inspect and adjust.

Inspection is easier if the front wheel is removed. Ask a dealer to lubricate the steering bearings every 4,000 miles (6,400 km) of operation.

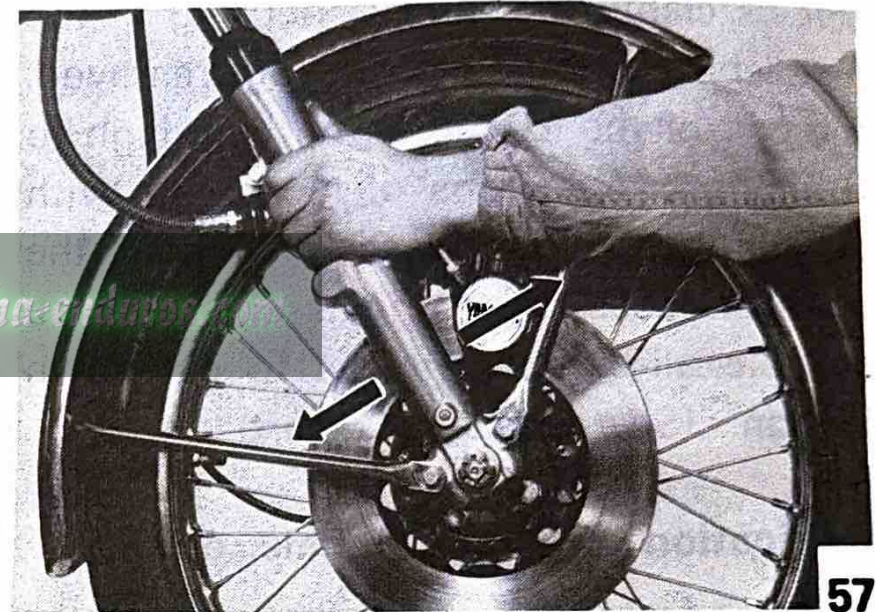

57

Front forks

At least every 2,000 miles (3,200 km) the front fork oil should be completely drained and refilled. Remove the Phillips head screws in the very bottom of the forks. Next, remove the fork cap found on top of each fork tube and most of the fork oil will drain out.

Compress the forks several times to pump all the remaining oil out. Slowly pour in 4.6 oz (137 cc) oil in each fork leg. (See Lubrication Recommendations section for type of oil.)

At least every other time you should have your mechanic dismantle the fork assembly and thoroughly clean out each fork. Water and dirt eventually coat much of the inner fork surfaces and cannot be readily removed just by draining.

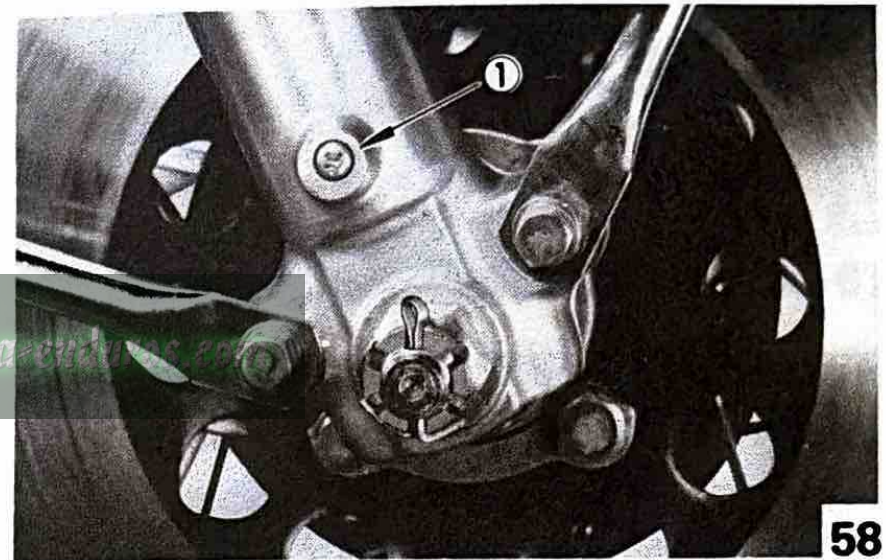

1. Oil drain screw

58

Front wheel removal

1. Remove speedometer cable from front brake shoe plate: First remove clip and then pull cable out.

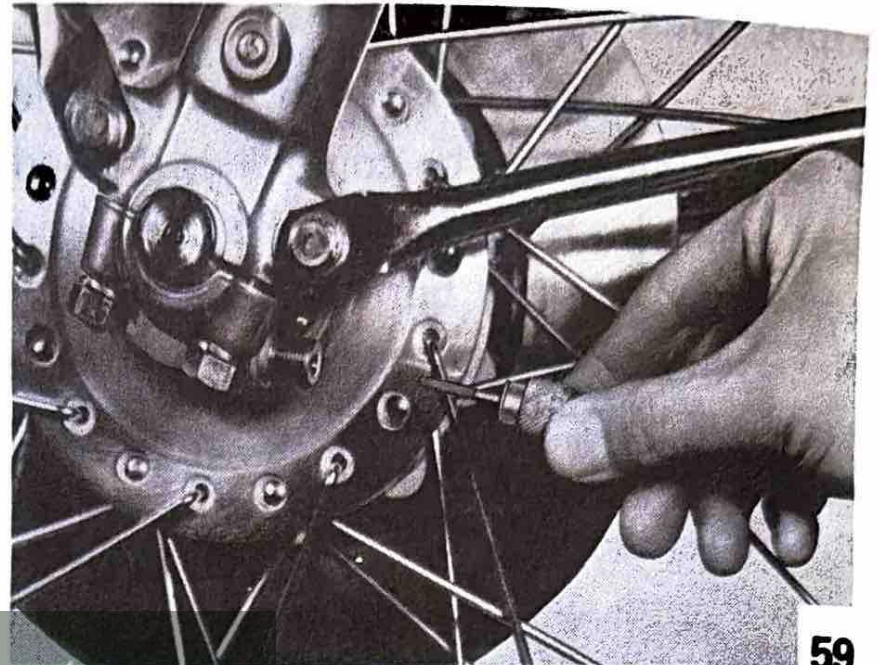

2. Remove the cotter pin from the front wheel axle and remove axle nut.

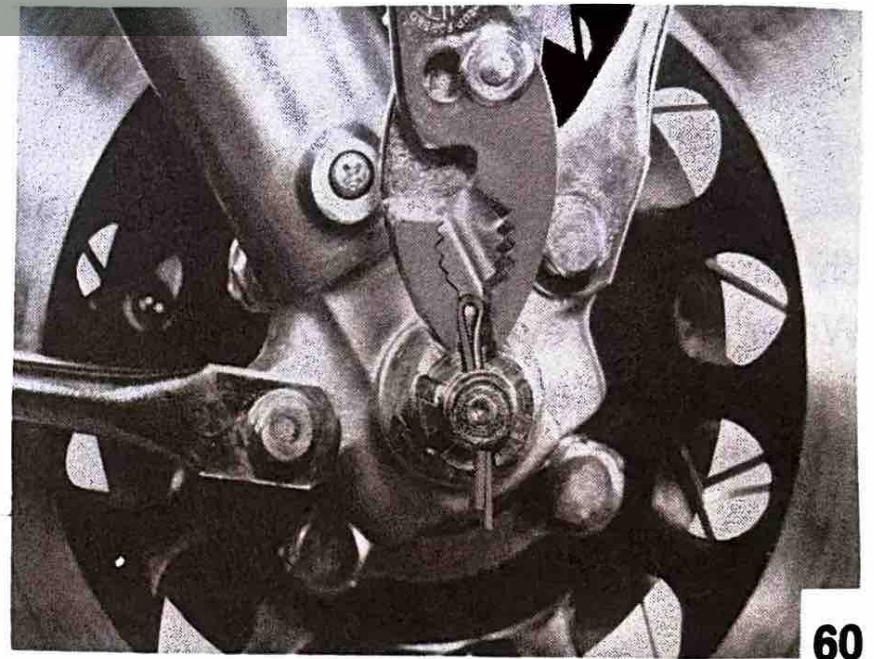

www.legends-yamaha-enduros.com

3. Loosen the axle holder nuts at other end of axle.

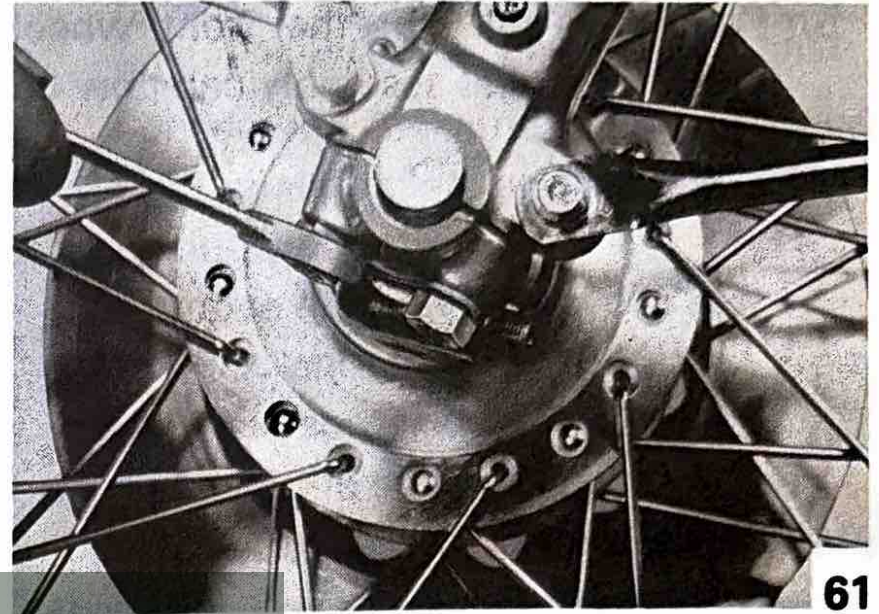

4. Elevate the front wheel by placing a suitable stand under engine.

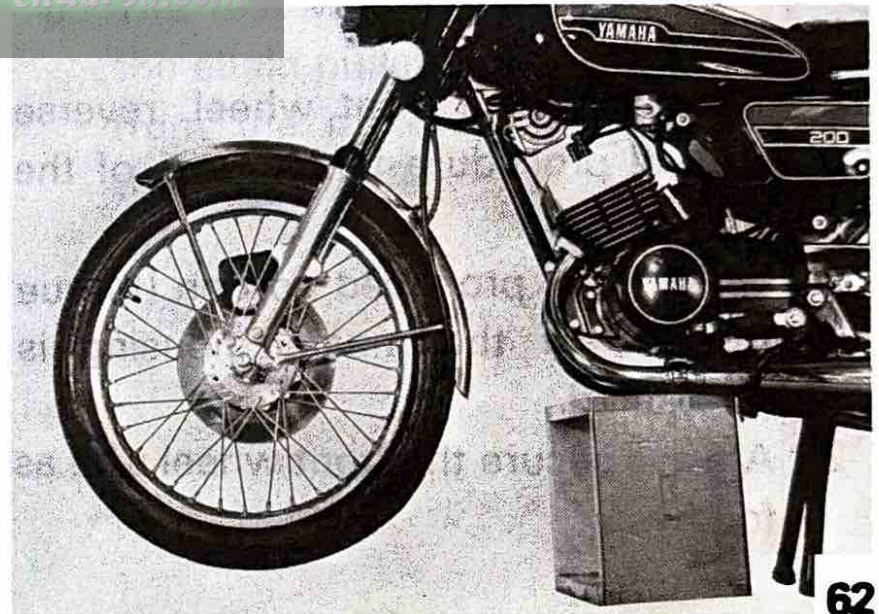

5. Turn and pull out the front wheel axle; the wheel assembly can now be removed.

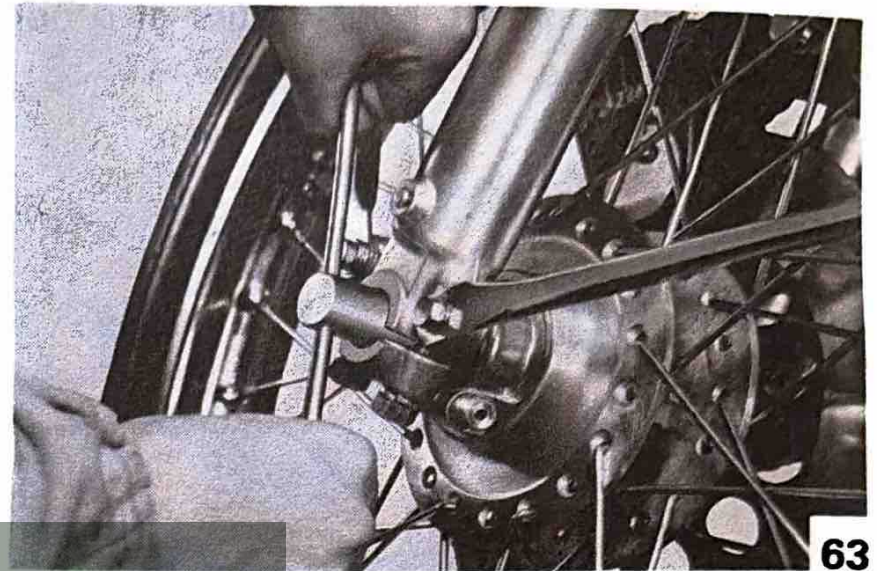

Front wheel installation

When installing the front wheel, reverse the removal procedure taking care of the following points:

1. Be sure the produced portion (torque stopper) of the master housing is positioned.
2. Always secure the front wheel axle as follows:

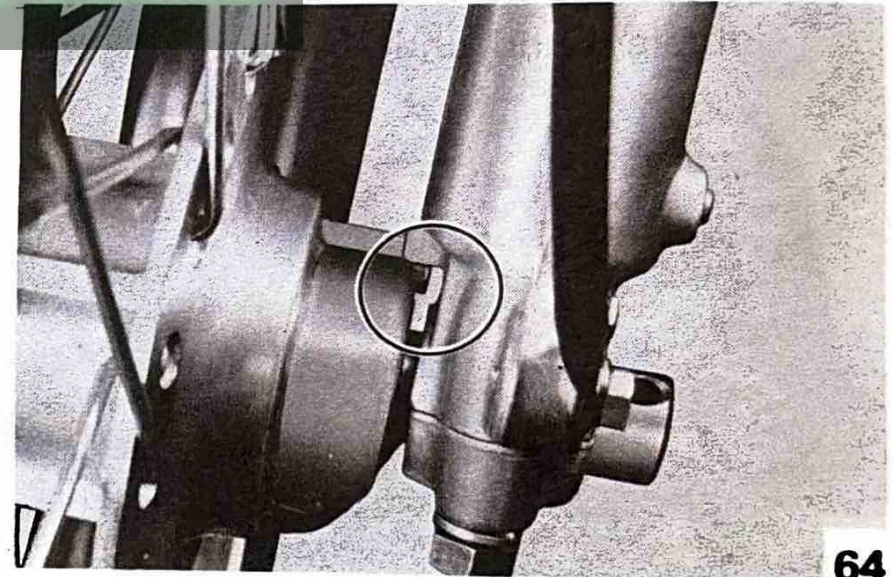

- a. Torque the front axle nut.
Axle nut:
48 ~ 76 ft-lb (6.6 ~ 10.5 m-kG)
- b. Install a new cotter pin; discard old pin.
- c. Torque the axle holder nuts in stages to maintain an equal gap on each side.
Holder nut torque:
12 ~ 19 ft-lb (1.6 ~ 2.6 m-kG)

Rear wheel removal

If the owner is not familiar with service, this work should be done by a Yamaha dealer.

1. Remove the muffler.
2. Remove the tension bar and the brake rod from the brake shoe plate. The tension bar can be removed by removing clip and nut from the tension bar bolt. The brake rod can be

- removed by removing the adjusting nut.
3. Loosen the locknuts of the left and right chain pullers and loosen the adjusting bolts.
4. Remove the master link clip and master link and remove the chain from the rear sprocket.
5. Remove the cotter pin from the wheel axle and loosen the rear wheel axle nut.
6. The rear wheel assembly, the collar, the chain puller, etc., can be removed from the motorcycle by pulling out the wheel axle.

Rear wheel installation

The rear wheel can be reassembled by reversing the disassembly procedure. Take care of the following points:

1. When connecting the chain, make certain closed the end of master link clip is facing the direction of rotation.
2. Be sure to adjust the tension of the chain. See "Drive chain section" for proper adjustment. (Page 63)
3. Adjust the brake pedal and stoplight switch. (Pages 61, 62)
4. Always use a new cotter pin. Old pins should be discarded.

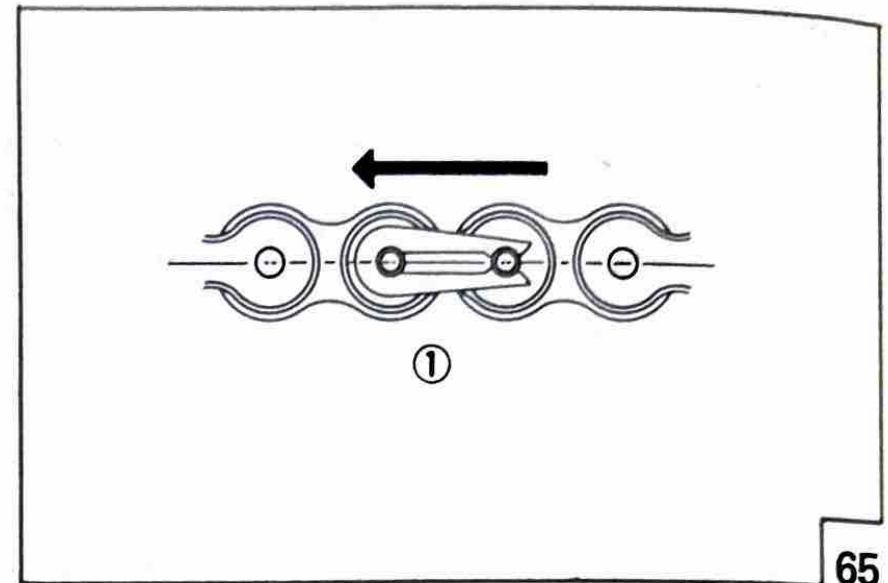

65

1. Direction of travel

Brake shoe inspection

Measure the outside diameter of the brake shoe set with slide calipers.

If it measures less than specified, replace the shoes. Smooth out any rough shoe surface with sandpaper.

Brake shoe diameter (rear):

4.92 in (125 mm)

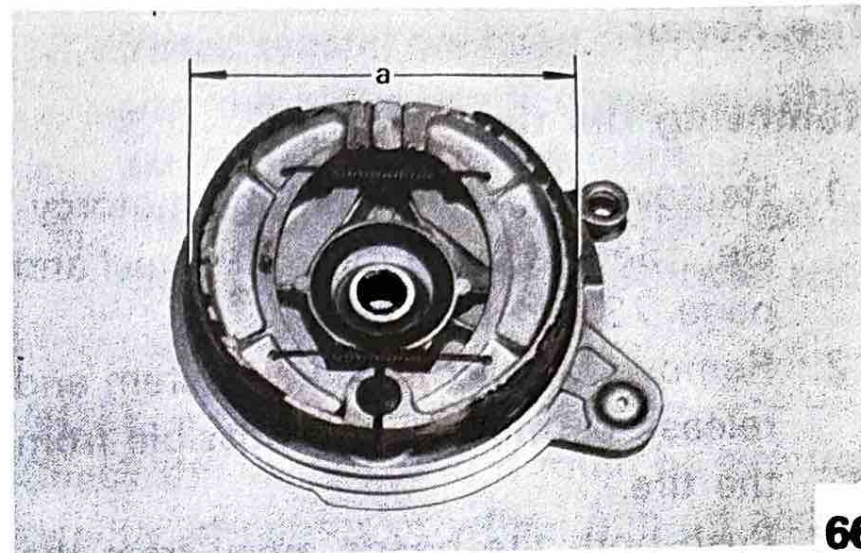

66

a: Brake shoe diameter

Brake drum inspection

The friction between the inner surface of the brake drum and the brake lining provides the energy to stop the motorcycle. If these become damaged or if oil contacts the drum, noise may occur and brake performance will suffer. Check the inner surface of the brake drum and remove any scratches with emery cloth. Remove any oil with a cloth dipped in solvent. If damage is more extensive, have a Yamaha dealer replace the wheel hub.

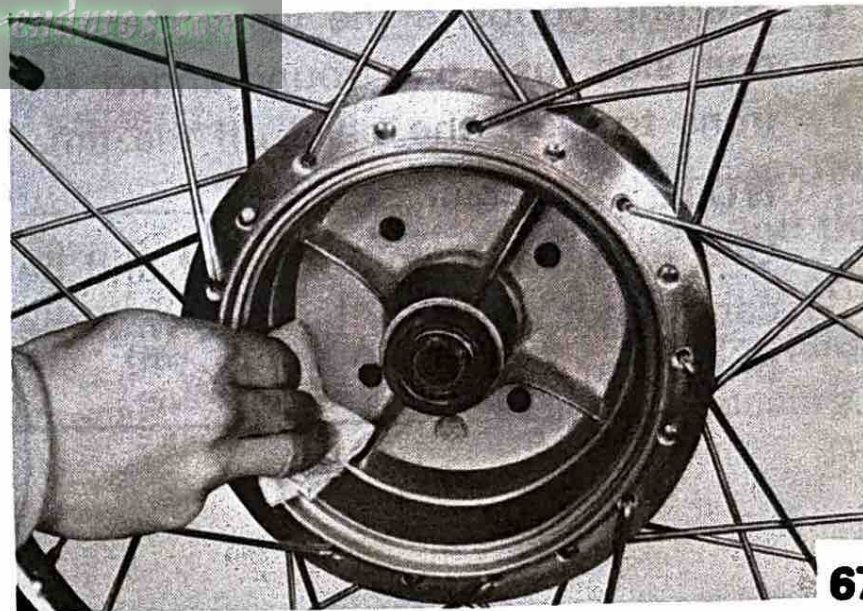

67

Tire Repair

Removing the tire

1. Remove the wheel from the motorcycle. (See page 70 for front wheel and page 73 for rear wheel.)
2. Remove locknut from valve stem and release as much air as possible from the tire.
3. Push both tire beads away from the edges of the rim.
4. Starting opposite the valve stem on one side, use two round-ended tire irons to work the bead off the rim.

NOTE: _____

Use a tire removal lubricant and be careful not to pinch the tube with the tire irons.

5. Remove the valve stem from its hole and remove the tube.
6. If the tire is to be changed, remove the second bead from the rim using the tire irons and tire lubricant.

Inspection

1. Use a cloth to check for nails or other sharp objects in the tire.

CAUTION: _____
Always use a cloth to avoid cutting your hand.

2. Check for faults in the side wall. If there is any fault, the tire should be replaced as a damaged tire may burst at high speed, which is extremely dangerous.

3. Inflate the tube with air and check the valve stem and the tube for damage and leakage. Replace as required. Some leaks can be patched in an emergency, but it is best to replace tube.
4. Inspect rim band and replace if damaged.

Reassembly

1. Install one tire bead on the rim using tire irons and lubricant and then install the tube.
2. Inflate tube with air to about one-third the specified pressure. Hit the outer circumference of the tire with a soft hammer to make certain the tube is not caught between tire and rim. Release air from tube.

3. Install second tire bead starting opposite the valve stem using tire irons and tire mounting lubricant.
4. Inflate tire to approximately 30 lb /in² and then reduce pressure to specified setting.

NOTE:

Check the valve stem; it must be pointing directly at center of wheel hub. If angled in any direction, release air and adjust tube position.

Tire air pressure

Improper tire pressure affects the smoothness of the tire, traction, handling and the life of the tires. Always maintain the proper tire pressure. (See "Preoperation checks" section for proper tire pressure.)

Rim and spokes

There are checks that you can perform to determine if wheel work is necessary for your dealer to do. First, check for any loose spokes. This can be checked by bracing the front end off the ground so that the front wheel can spin free. Slowly revolve the front wheel and at the same time let the metal shaft of a fairly heavy screwdriver bounce off each spoke. If all the spokes are tightened approximately the same, then the sound given off by the screwdriver hitting the spokes should sound the same. If one spoke makes a dull flat sound, then check it for looseness.

While you have the front end up in the air, you should check that the front wheel does not have too much run-out. "Run-out" is the amount the front wheel deviates from a straight line as it spins.

Secure the front forks from turning, spin the front wheel, and solidly anchor some sort of a pointer about 1/8 in (4 mm) away from the side of the rim.

As the wheel spins, the distance between the pointer and the rim should not change more than 1/16 in (2 mm) total. Any greater fluctuation means that you should have your dealer remove this rim warpage by properly adjusting the spokes.

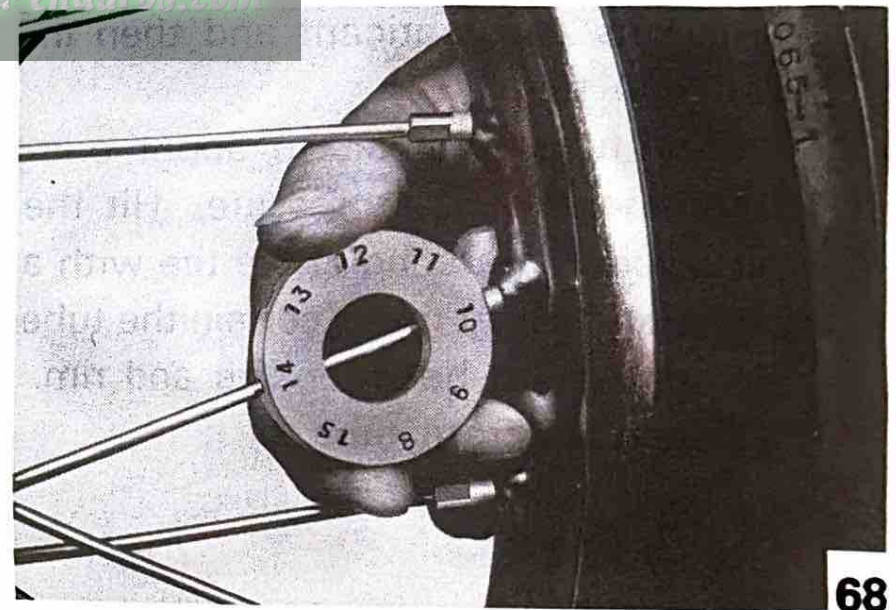

Headlight beam adjustment

When necessary, adjust the headlight beam as follows:

1. Adjust horizontally by tightening or loosening the adjusting screw, as in the illustration.

To adjust to the right: tighten the screw

To adjust to the left: loosen the screw

2. Adjust vertically by moving the headlight body.

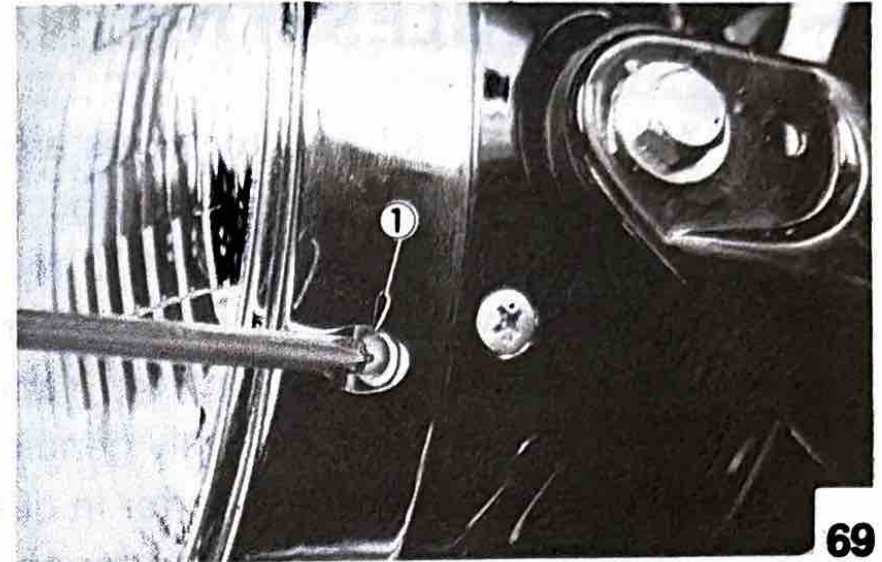

1. Adjusting screw

69

Replacing the headlight bulb

This motorcycle is equipped with a sealed beam headlight. If the headlight burns out, ask your Yamaha dealer for a lens unit replacement and adjustment.

TROUBLESHOOTING

Although Yamaha motorcycles are given a right inspection before shipment from the factory, trouble may occur in operation. If this happens check the motorcycle in accordance with the procedures given in the troubleshooting chart below. If repair is necessary, ask your Yamaha dealer.

The skilled technicians at your Yamaha dealer provide excellent service. For replacement parts, use only genuine Yamaha part. Imitation parts are similar in shape but often inferior in quality of materials and workmanship; consequently, service life is shorter and more expensive repairs may be necessitated.

www.legends-yamaha-enduros.com

Any fault in the fuel, compression or ignition system can cause poor starting or loss of power while driving. The troubleshooting chart describes quick and easy procedures for checking these system. (See next page.)

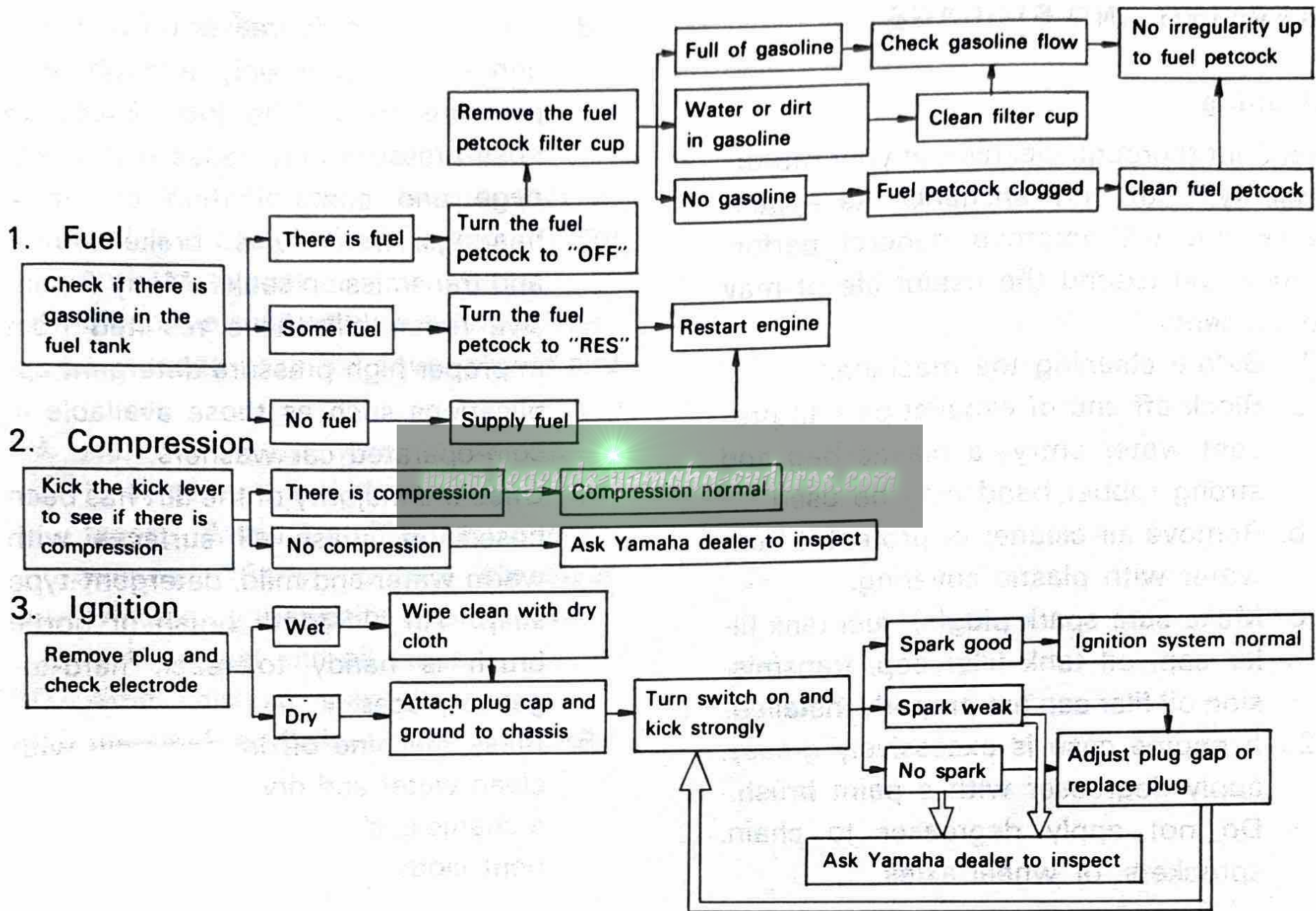

CLEANING AND STORAGE

Cleaning

Frequent thorough cleaning of your motorcycle will not only enhance its appearance but will improve general performance and extend the useful life of many components.

1. Before cleaning the machine:
 - a. Block off end of exhaust pipe to prevent water entry- a plastic bag and strong rubber band may be used.
 - b. Remove air cleaner or protect it from water with plastic covering.
 - c. Make sure spark plug(s), fuel tank filler cap, oil tank filler cap, transmission oil filler cap are properly installed.
2. If engine case is excessively greasy, apply degreaser with a paint brush. Do not apply degreaser to chain, sprockets, or wheel axles.
3. Rinse dirt and degreaser off with garden hose, using only enough hose pressure to do the job. Excessive hose pressure may cause water seepage and contamination of wheel bearings, front forks, brake drums, and transmission seals. Many expensive repair bills have resulted from improper high pressure detergent applications such as those available in coin-operated car washers.
4. Once the majority of the dirt has been hosed off, wash all surfaces with warm water and mild, detergent-type soap. An old tooth brush or bottle brush is handy to reach hard-to-get-to places.
5. Rinse machine off immediately with clean water and dry all surfaces with a chamois, clean towel, or soft absorbent cloth.

6. Immediately after washing, remove excess moisture from chain and lubricate to prevent rust.
7. Chrome-plated part such as handlebars, rims, spokes, forks, etc., may be further cleaned with automotive chrome cleaner.
8. Clean the seat with a vinyl upholstery cleaner to keep the cover pliable and glossy.
9. Automotive-type wax may be applied to all painted and chrome-plated surfaces. Avoid combination cleaner-waxes. Many contain abrasives which may mar paint or protective finish on fuel and oil tanks.
10. After finishing, start the engine immediately and allow to idle for several minutes.

Storage

Long term storage (30 days or more) of your motorcycle will require some preventive procedures to insure against deterioration. After cleaning machine thoroughly, prepare for storage as follows:

1. Drain fuel tank, fuel lines, and carburetor float bowl(s).
2. Remove empty fuel tank, pour a cup of 10W to 30W oil in tank, shake tank to coat inner surfaces thoroughly and drain off excess oil. Re-install tank.
3. Remove spark plug(s), pour about one tablespoon of 10W to 30W oil in spark plug hole(s) and re-install spark plugs. Kick engine over several times (with ignition off) to coat cylinder walls with oil.
4. Remove drive chain. Clean thoroughly with solvent and lubricate. Re-install chain or store in a plastic bag (tie to frame for safe-keeping).

5. Lubricate all control cables.
6. Block up frame to raise both wheels off ground. (Main stands can be used on machines so equipped.)
7. Deflate tires 15 lb/in² (1.1 kg/cm²).
8. Tie a plastic bag over exhaust pipe outlet(s) to prevent moisture from entering.
9. If storing in humid or salt-air atmosphere, coat all exposed metal surfaces with a light film of oil. Do not apply oil to rubber parts or seat cover. Remove battery and charge. Store in a dry place and re-charge once a month. Do not store battery in an excessively warm or cold place (less than 32°F (0°C), or more than 90°F (32°C)).

NOTE: _____
Make any necessary repairs before storing the motorcycle.

MISCELLANEOUS

Consumer Information

Stopping distance

This figure indicates braking performance that can be met or exceeded by the vehicles to which it applies, without locking the wheels, under different conditions of loading and with partial failures of the braking system. The information presented represents results obtainable by skilled drivers under controlled road and vehicle conditions and the information may not be correct under other conditions.

Description of vehicles to which this table applies: Yamaha motorcycle RD200C

A. Fully Operational Service Brake legends-yamaha-enduros.com

Load

Light

Maximum

180

185

0 100 200 300

Stopping distance in feet from 60 mi/h.

Acceleration and passing ability

This figure indicates passing times and distances that can be met or exceeded by the vehicles to which it applies, in the situations diagrammed below.

The low-speed pass assumes an initial speed of 20 mi/h. and a limiting speed of 35 mi/h. The high-speed pass assumes an initial speed of 50 mi/h. and a limiting speed of 80 mi/h.

Notice: The information presented represents results obtainable by skilled drivers under controlled road and vehicle conditions, and the information may not be correct under other conditions.

Description of vehicles to which this table applies: Yamaha motorcycle RD200C

Summary table:

| | | |
|----------------------|-------------|--------------|
| Low-speed pass | 365 feet: | 7.5 seconds |
| High-speed pass..... | 1,330 feet: | 15.0 seconds |

Low-speed

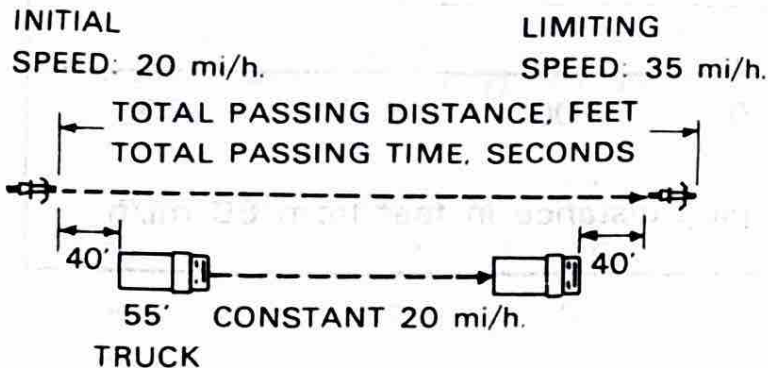

High-speed

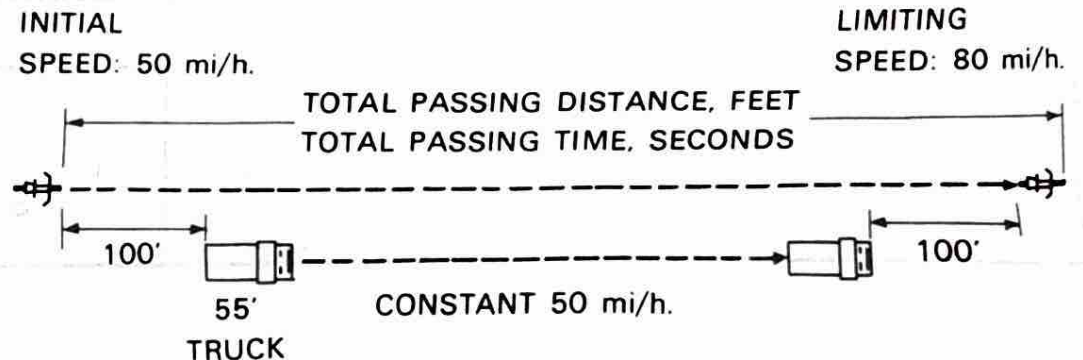

WARRANTY INFORMATION

Study your Owner's Warranty Guide Book thoroughly. It contains your Warranty Policy, an explanation of the policy, break-in procedures and the recommended service schedules. Becoming familiar with these items will be to your advantage in making the best use of Yamaha's warranty program.

The acceptance of any warranty claim that your dealer might submit in the future depends greatly on just what has been done to the motorcycle. IF ANY PARTICULAR FAILURE CAN BE TRACED DIRECTLY TO A REPAIR OR MAINTENANCE PERFORMED INCORRECTLY, THE WARRANTY CLAIM MAY NOT BE ACCEPTED. For this reason, we recommend that all services beyond those detailed in this manual be performed by a qualified mechanic at an authorized Yamaha dealer.

There are certain requirements that must be met to qualify for warranty coverage.

1. Your machine must be registered for warranty. This is accomplished when the Warranty Registration card is filled out by you and mailed by the dealer to Yamaha International at the time of purchase.

2. Your Owner's Warranty Guide Book outlines the owner-responsibility service schedules and provides a maintenance record for your protection and convenience. Proper maintenance will insure a trouble free life for your new Yamaha.
3. If any problems occur which you feel should be covered under warranty, **NOTIFY YOUR DEALER IMMEDIATELY**. Do not delay, as little problems left unrepaired can become large problems which may not be covered under warranty.

www.legends-yamaha-enduros.com

– MEMO –

www.legends-yamaha-enduros.com

- MEMO -

www.legends-yamaha-enduros.com

— MEMO —

www.legends-yamaha-enduros.com

– MEMO –

www.legends-yamaha-enduros.com

www.legends-yamaha-enduros.com



YAMAHA MOTOR CO., LTD.

LIT-11625-07-01

SINCE 1887

IWATA, JAPAN

PRINTED IN JAPAN
75 · 3 · 2.0 x 1 ©