



YAMAHA

www.legends-yamaha-enduros.com

DT250F

ASSEMBLY MANUAL



FOREWORD

The Assembly Manual contains the information required to unpack and assemble Yamaha motorcycles correctly prior to delivery to the customer. Proper motorcycle set-up assembly and pre-delivery service demands a basic knowledge of motorcycle service procedures, familiarity with Yamaha products, and correct tools. This assembly manual should be used with the Dealer Set-up and Pre-delivery Check List, Service Manual, and Parts List for this model.

Proper set-up, assembly and pre-delivery service is necessary for the following reasons:

- To assure the customer of the long life and performance he expects from his new Yamaha motorcycle.
- To minimize service problems during the break-in period.
- To conform with federal new vehicle regulations.



www.legends-yamaha-enduros.com

NOTICE

The service specifications given in this manual are based on the model as manufactured. Modifications and significant changes in specifications and/or procedures will be forwarded to all Authorized Yamaha Dealers.

The procedures below are described in the order that the mechanic should follow. Special care should be taken to ensure that the procedures are carried out correctly and completely. Failure to do so can result in poor performance, excessive emissions, and possible harm to the machine and/or rider.

The DEALER SET-UP AND PRE-DELIVERY CHECK LIST has been designed to be used with this Assembly Manual. As each procedure is satisfactorily completed, the mechanic should mark the appropriate space on the sheet. After it has been signed by the assembling mechanic, the servicing mechanic, and the customer, a copy of the Check List should be given to the customer and another copy retained in the dealership files. If the Service Manager test rides the machine before delivery, he should also sign the Check List.

CONCERNING CRATE DAMAGE:
Follow the instructions in the Dealer Warranty Handbook,
Procedure Section.

Particularly important information is distinguished in this manual by the following notations:

NOTE: A NOTE provides key information to make procedures easier or clearer.

CAUTION: A CAUTION indicates special procedures that must be followed to avoid damage to the machine.

WARNING: . . . A WARNING indicates special procedures that must be followed to avoid injury to a machine operator or person inspecting or repairing the machine.



**DT250F
ASSEMBLY MANUAL
1ST EDITION, OCTOBER 1978
OVERSEAS SERVICE DEPARTMENT
YAMAHA MOTOR CO., LTD.
IWATA, JAPAN
PRINTED IN JAPAN
LIT-11666-01-25**

PREPARATION

To assemble the machine correctly, the following service tools, supplies and working space are required.

UNPACKING

Note on transportation

Use care not to butt the machine packed in the crate against a hard object or give it a heavy shock during transportation or in the service shop.

Procedure for unpacking

To remove the machine and parts packed in the cardboard crate, cut the vinyl bands around the box using a cutter or scissors.

Next, remove the exterior carton by lifting it straight up.

Remove the styrofoam case, front wheel, front fender and carton box.

Next, remove the nails from each corner of crate, and remove the struts.

CHECK LIST

Part list: Cardboard crate

No.	Part name	Q'ty
1	Styrofoam case	1
2	Front wheel	1
3	Front fender	1
4	Carton box	1

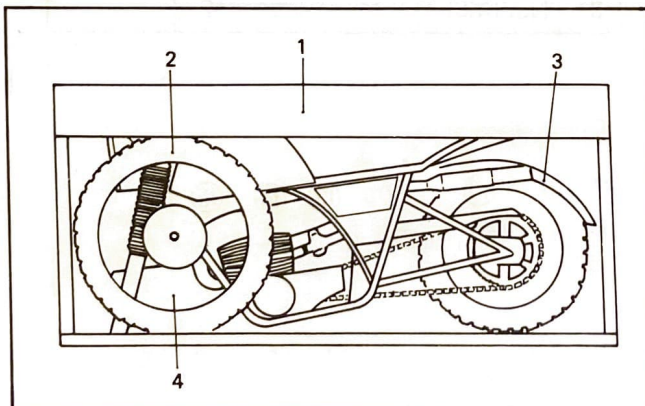

Part list: Styrofoam

No.	Part name	Q'ty
1	Front flasher light (R)	1
2	Front flasher light (L)	1
3	Rear flasher light	2
4	Taillight ass'y	1
5	Licence bracket	1
6	Brake shoe comp.	1
7	Handlebar ass'y	1
8	Meter ass'y	1
9	Footrest (L)	1
10	Meter cable	1
11	Headlight unit	1
12	Vinyl bag B	1

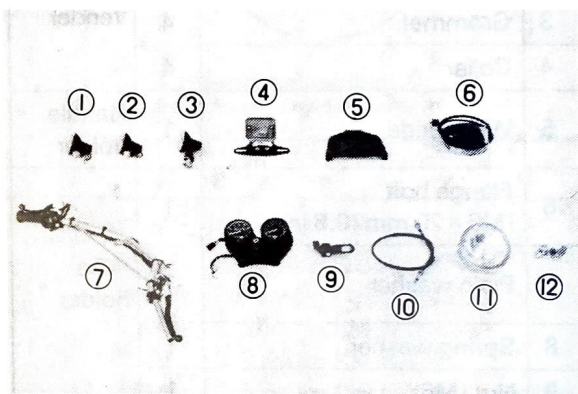

Part list: Vinyl bag B

No.	Part name	Q'ty	Remarks
1	Handle upper holder	2	Handlebar
2	Flange bolt [M8 × 35mm (1.4 in)]	4	
3	Collar	1	F. wheel
4	Nut (M12)	1	Footrest
5	Hexagon head bolt with washer [M6 × 30mm (1.2 in)]	2	Meter



Part list: Carton box

No.	Part name	Q'ty
1	Owner's manual	1
2	Tool kit	1
3	Rear view mirror	1
4	Wire holder	1
5	Tank breather hose	1
6	Rear reflector	1
7	Flasher stay	2
8	Vinyl bag A	1

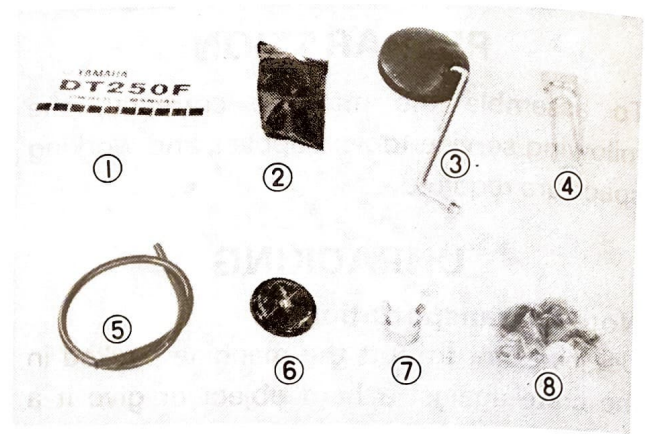

Part list: Vinyl bag A

No.	Part name	Q'ty	Remarks
1	Bolt with washer [M6 × 25 mm (1.0 in)]	4	Front fender
2	Plate washer	4	
3	Grommet	4	
4	Collar	4	
5	Wire guide	1	Handle holder
6	Flange bolt [M6 × 20 mm (0.8 in)]	1	Wire holder
7	Plain washer	1	
8	Spring washer	1	
9	Nut (M6)	1	
10	Split pin	1	F. wheel
11	Nut (M8)	2	F. flasher
12	U-nut (M10)	2	R. flasher
13	Spring washer	1	Reflector
14	Plain washer	1	
15	Nut (M5)	1	

No.	Part name	Q'ty	Remarks
16	Bolt with washer [M6 × 16 mm (0.6 in)]	2	Licence bracket
17	Plate washer	2	
18	Nut (M6)	2	
19	Plate washer	2	Taillight assembly (Front part)
20	Bolt with washer [M6 × 25 mm (1.0 in)]	1	
21	Damper	1	
22	Damper	1	
23	Plate washer	1	
24	Collar	1	Taillight assembly (Rear part)
25	Nut (M6)	1	
26	Bolt with washer [M6 × 35 mm (1.4 in)]	2	
27	Damper	1	
28	Damper	2	
29	Collar	2	Reflector
30	Plate washer	2	
31	Nut (M6)	2	



TORQUE SPECIFICATIONS

The list at right covers those stud/bolt sized with standard I.S.O. pitch threads. Torque specifications for components with thread pitches other than standard are given within the applicable chapter.

Torque specifications call for dry, clean threads. Components such as the cylinder or cylinder head should be at room temperature prior to torquing. A cylinder head or any other item with several fasteners should be torqued down in a crisscross pattern in successive stages until torque specification is reached. The method is similar to installing an automobile wheel and will avoid warping the component.

Standard Torque Setting

A (NUT)	B (BOLT)	TORQUE SPECIFICATION	
		m-kg	ft-lb
10 mm	6 mm	0.6	4.5
12 mm	8 mm	1.5	11.0
14 mm	10 mm	3.0	22.0
17 mm	12 mm	5.5	40.0
19 mm	14 mm	8.5	61.0
22 mm	16 mm	13.0	94.0

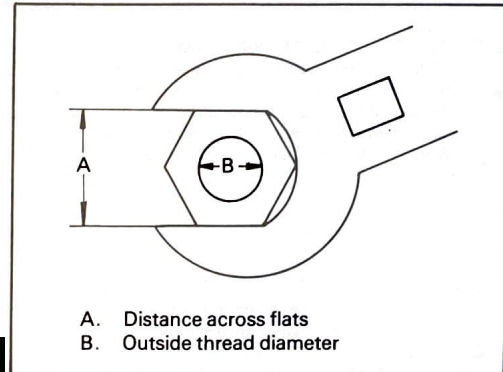

www.legends-yamaha-enduros.com

Engine	Tightening torque	
Cylinder head — Nut	M8	2.5 m-kg (18 ft-lb)
— Stud bolt	M8	2.5 m-kg (18 ft-lb)
Cylinder — Nut	M10	3.3 m-kg (24 ft-lb)
— Stud bolt	M10	3.3 m-kg (24 ft-lb)
Spark plug	M14	2.5 m-kg (18 ft-lb)
Clutch boss	M20	7.5 m-kg (54 ft-lb)
Push rod 1	M8	1.5 m-kg (10 ft-lb)
Primary drive	M18	7.5 m-kg (54 ft-lb)
Drive sprocket	M18	7.5 m-kg (54 ft-lb)
Flywheel magneto	M12	8.3 m-kg (60 ft-lb)
Chassis	Tightening torque	
Engine mount — front	M8	2.5 m-kg (18 ft-lb)
— rear, upper	M8	2.5 m-kg (18 ft-lb)
— rear, lower	M10	4.0 m-kg (29 ft-lb)
Front fender	M6	0.4 m-kg (3 ft-lb)
Mud guard	M6	0.4 m-kg (3 ft-lb)
Pivot shaft	M14	6.5 m-kg (47 ft-lb)
Tensioner arm	M10	1.5 m-kg (10 ft-lb)
Rear shock absorber	M10	2.5 m-kg (18 ft-lb)
Handle crown — Inner tube	M10	3.3 m-kg (24 ft-lb)
— Steering pinch bolt	M8	2.3 m-kg (16 ft-lb)
— Steering	M14	5.3 m-kg (38 ft-lb)
— Handle holder	M10	3.2 m-kg (23 ft-lb)
Handle holder, upper	M8	2.0 m-kg (14 ft-lb)
Front wheel axle	M14	7.7 m-kg (56 ft-lb)
Rear wheel axle	M16	8.7 m-kg (62 ft-lb)
Sprocket wheel gear	M10	4.0 m-kg (28 ft-lb)
Footrest ass'y	M12	6.0 m-kg (42 ft-lb)



YAMAHA MOTORCYCLE

DEALER SET-UP AND PRE-DELIVERY CHECK LIST

I hereby certify that prior to delivery to the retail purchaser, assembly and pre-delivery service was performed on the motorcycle listed below in accordance with the following check list and in compliance with established procedures prescribed by Yamaha.

MODEL _____ FRAME NO. _____ ENGINE NO. _____

Assemble according to the assembly manual and any technical bulletin information that applies to this particular model. Pay special attention to the following items.

SET-UP ASSEMBLY

- FRONT FORK PINCH BOLTS — Torque to specification
- FRONT WHEEL AND AXLE — Torque axle and axle holder to specification
- FRONT AXLE COTTER PIN — Install
- HANDLEBAR HOLDER (spring tension type) — Position die marks on holder to front, torque to specifications
- HANDLEBAR HOLDER (standard) — tighten bolts evenly, in a crisscross pattern until proper torque is attained
- WIRING CONNECTORS — Check for color code and proper connection
- FRONT BRAKE CABLE (drum brake) — Install
- MASTER CYLINDER (disc brake) — Install
- INSTRUMENTS -- Install instruments and route the cables as shown on cable routing diagrams
- TAILLIGHT — Install on applicable models
- BRAKE PEDAL — Install per assembly manual
- ALL NUTS AND BOLTS — Check tightness and proper torque
- CONTROLS — Check for proper operation
- KEYS — Check all locks for proper operation

SET-UP BY _____ DATE _____

PRE-DELIVERY SERVICE

- ALL NUTS AND BOLTS — Check for torque and tightness, especially Engine mounting bolts and/or nuts Steering head, Rear swing arm pivot shaft Axles
- HYDRAULIC DISC BRAKES (front & rear) — Check master cylinder fluid level, bleed systems, check and adjust free play, and check operation
- TWIN FRONT DISC BRAKE — Check clearances between caliper brackets and disc, reposition if necessary
- TIRES-Adj. pressure: front _____ rear _____
- SPOKES — Check tightness
- FUEL FILTER SCREEN AND FUEL LINE — Clean and check for connection lightness
- CARBURETOR — Drain stale fuel from lines and float bowls
- CARBURETOR — Tighten caps and mounting bolts
- CARBURETOR — Adjust starter lever freeplay (if applicable)
- CARBURETOR — Adjust throttle cable freeplay
- MECHANICAL BRAKES — Check and adjust freeplay, check operation
- CLUTCH — Check and adjust freeplay
- COMPRESSION RELEASE CABLE (if applicable) — Check and adjust freeplay
- ENGINE/TRANSMISSION OIL — Drain and refill, qty _____ type _____
- SHAFT DRIVE GEAR OIL LEVELS — Check oil levels, add as necessary
- BATTERY — Charge until specific gravity reaches 1.26 ~ 1.28 according to Service Manual procedure. Install and route breather tube checking for restrictions
- ELECTRICAL COMPONENTS — Check for proper operation of: Headlamp (Hi, Lo) Turn signals, (Stoplight front, rear), Taillight, Indicator lights, Instrument light, Horn
- DRIVE CHAIN — Lubricate, if necessary, and adjust, align rear wheel
- FOAM AIR FILTER — Service

2-STROKE ONLY:

- AUTOLUBE TANK — Fill tank, oil type _____ Check breather tube routing
- AUTOLUBE PUMP — Bleed air from pump and all lines
- AUTOLUBE PUMP — Adjust cable and check minimum stroke
- AUTOLUBE OIL DELIVERY — Check oil delivery to cylinders and for leaks

EXHAUST EMISSIONS CONTROL

The following items are related to emissions control. Check and adjust if necessary in accordance with the Yamaha published service manual and technical bulletins for this particular model.

- CAM CHAIN TENSIONER (If applicable) — Adjust
- VALVES — Clearance: Intake _____ mm, Exhaust _____ mm
- SPARK PLUG GAP — Check _____ mm
- IGNITION POINTS (if applicable) — Check gap _____ mm
- IGNITION TIMING Check: Idle Advance
- CARBURETOR — Check synchronization (if applicable)
- IDLE SPEED Check; _____ r/min

- TEST RIDE — Check performance, handling and operation, adjust mirrors
- OPTIONAL SERVICE MANAGER TEST RIDE _____

CUSTOMER CHECK LIST

- RECEIVED TOOL KIT (if applicable)
- RECEIVED OWNERS WARRANTY GUIDE
- RECEIVED OWNERS MANUAL
- RECEIVED SERVICE INSTRUCTIONS

CUSTOMER _____ DATE _____

Service manager Signature

I have performed this pre-delivery adjustments are specified in the assembly manual, service specifications and any technical bulletins applying to this model.

PRE-DELIVERED BY _____ DATE _____

DEALERSHIP NAME _____

DEALER NO. _____

ADDRESS _____

CITY/STATE/ZIP CODE _____

SET-UP PROCEDURES

1. To install the front fender and front wheel, place a proper-size wooden box or a wooden block under the engine to keep the front of the machine raised off the floor. Take care so that the machine does not fall over.
2. Insert the front fender between the front fork legs, and secure the front fender using the bolts with washers, fender collars, plate washers and dampers.

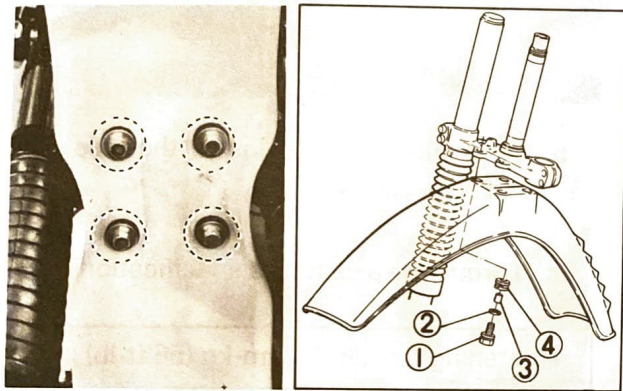

1. Bolt with washer 2. Plate washer
3. Collar 4. Damper

Tightening torque: 0.4 m·kg (3 ft·lb)

NOTE:

The front fender should be installed with the arrow mark in the right facing forward.

3. Apply a light coat of grease to the speedometer drive gear and oil seal.

CAUTION:

Take care not to put grease on the brake linings or inner surface of the brake drum. If you do so, clean using a rag dampened with a solvent. Foreign material on braking surface can cause impaired braking action.

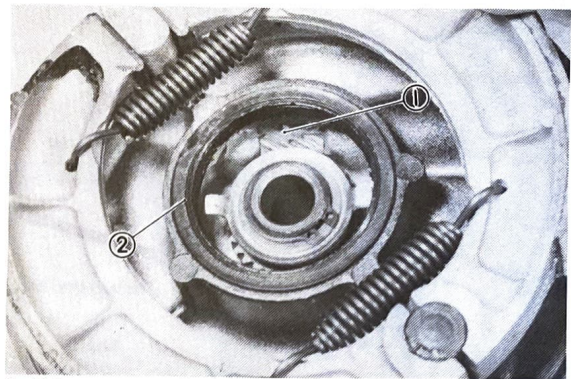

1. Drive gear 2. Oil seal

4. Remove the front wheel axle nut and plain washer. Then remove the wheel axle.

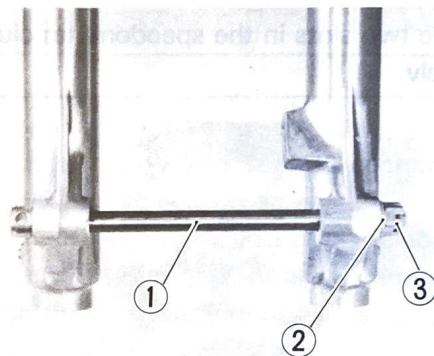

1. Wheel axle 2. Plain washer 3. Axle nut

5. Install the brake shoe plate assembly in the front wheel hub.
 - a. Clean the inner surface of the front wheel hub with a clean cloth.

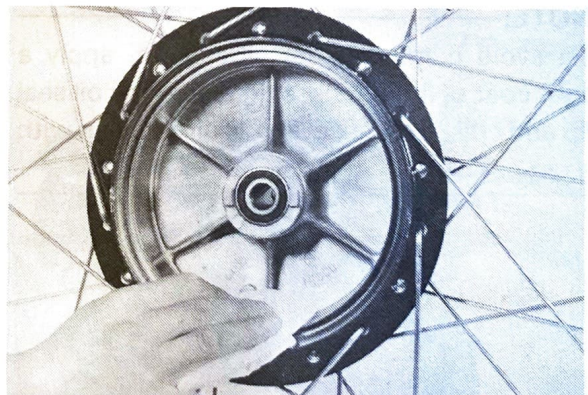

- b. Make sure the brake shoes and springs are correctly installed in the shoe plate assembly. If any one of them is out of position, correct per the figure.

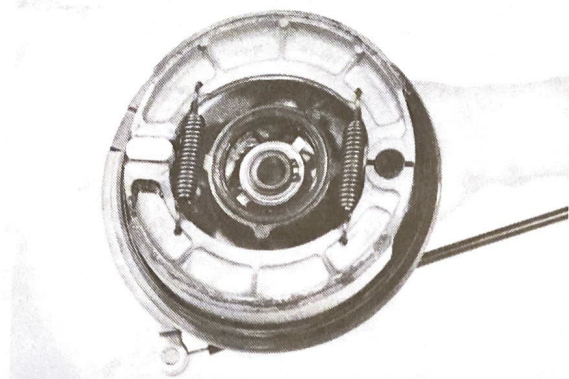

c. Install the brake shoe plate assembly in the wheel hub.

NOTE:

Make sure the two legs in the wheel hub align with the two slots in the speedometer clutch assembly.

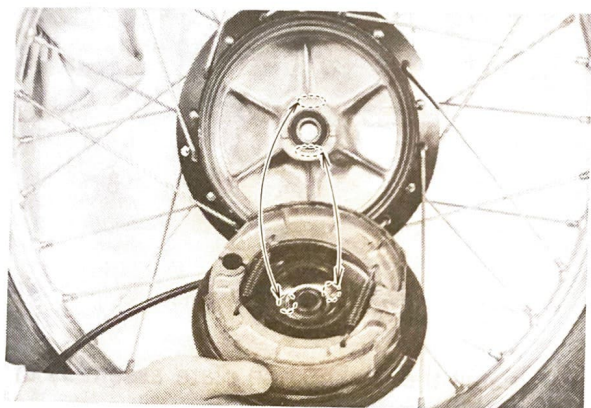

6. Install the wheel axle collar in the wheel hub on the right side of the front wheel.

NOTE:

To avoid damaging the oil seal lip, apply a light coat of lithium base grease to the oil seal lip and collar. If the collar has dirty, clean with a rag.

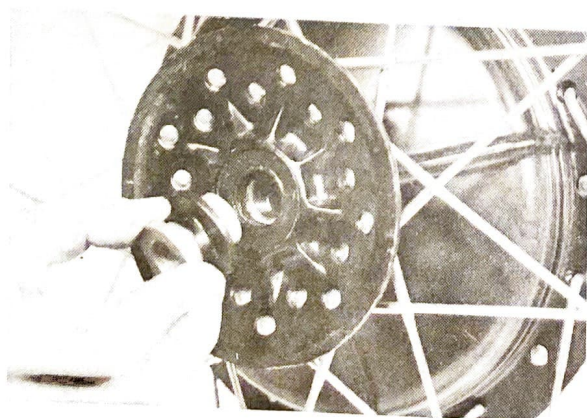

7. Install the front wheel on the front forks.
 - a. Insert the front wheel between the front fork legs so that the stopper (projection) on the front fork end has correctly engaged the slot in the brake shoe plate.

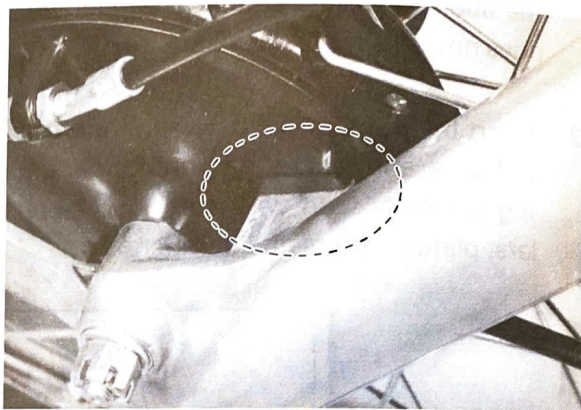

- b. Insert the axle, and install the axle nut and plain washer.
- c. Torque the axle nut to specification.

Tightening torque: 7.7 m-kg (56 ft-lb)

- d. Lock the nut with the cotter pin. The pin should be inserted downward, and the pin ends should be bent.

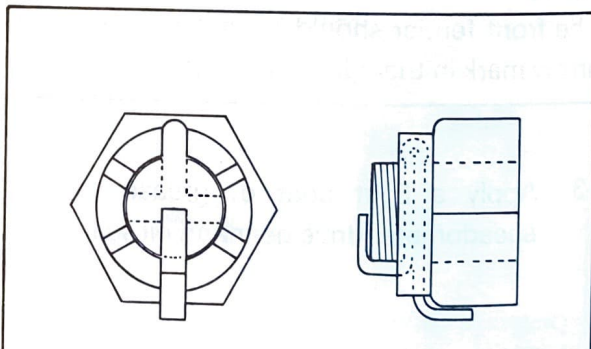

www.legends-yamaha-enduros.com

8. Install the speedometer and front brake cables to the front wheel hub.
 - a. Connect the speedometer cable to the front wheel hub gear unit. Insert the cable end into the gear unit, fit the circlip in the groove on the wheel hub side, and lock the cable. (The circlip is already attached to the cable.)

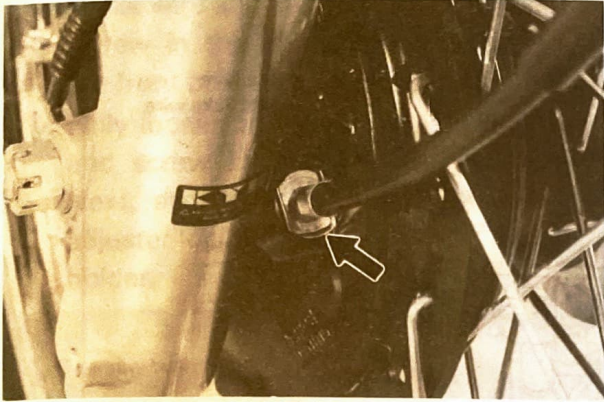

b. Insert the front brake wire end to the camshaft lever and hook the outer cable end onto the adjuster.

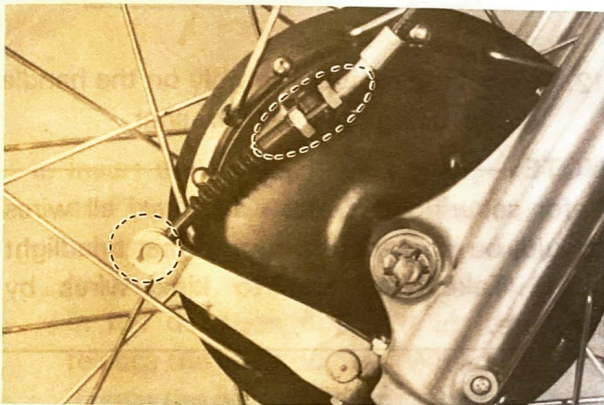

9. Install the wire holder to the left side of front fork outer tube using flange bolt, plain and spring washers and nut.

* For detailed cable routing refer to "CABLE ROUTING DIAGRAM"

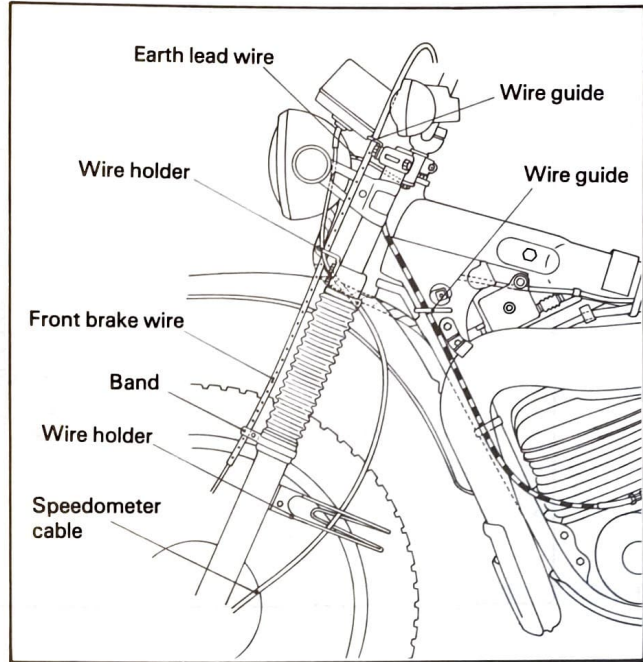
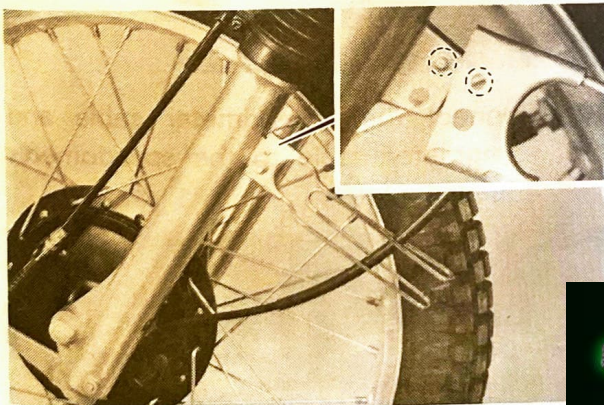

10. Loosen the two screws securing the throttle housing assembly.

Grease the right end of handlebar and the throttle grip housing. Install the throttle grip and tighten the screws.

CAUTION:

Make certain throttle grip rotates on handlebar freely without binding. If not, normal throttle return will be impaired.

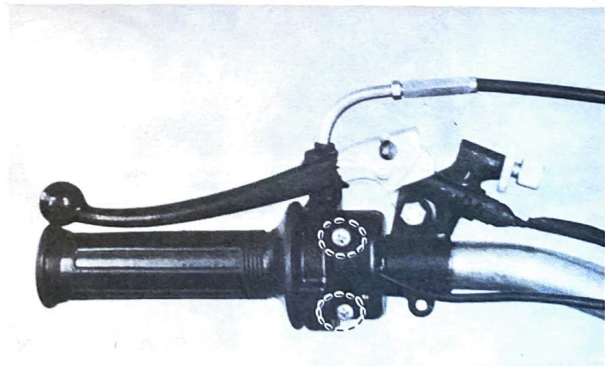

www.legends-yamaha-enduros.com

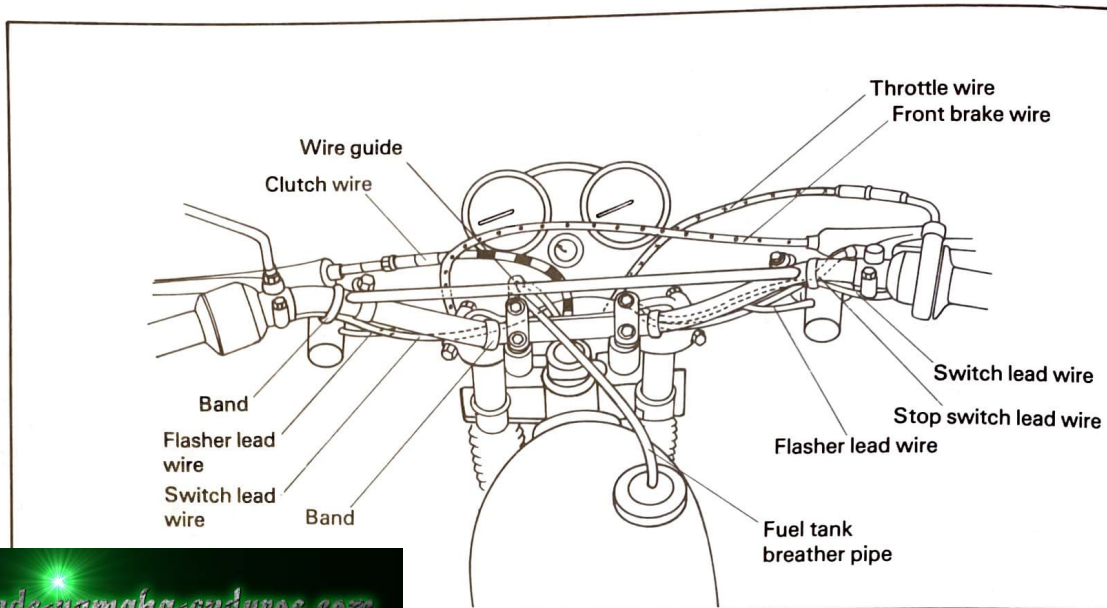

www.legends-yamaha-enduros.com

11. Handlebar installation

- a. Insert all lead wires coming from the handle switches into the headlight body.
- b. Install the handlebar using the two upper holders, wire holder and four flange bolts.

Tightening torque: 2.0 m·kg (14 ft·lb)

CAUTION:
 First tighten the bolts on the front side of the handlebar holder and tighten the bolts on the rear side.

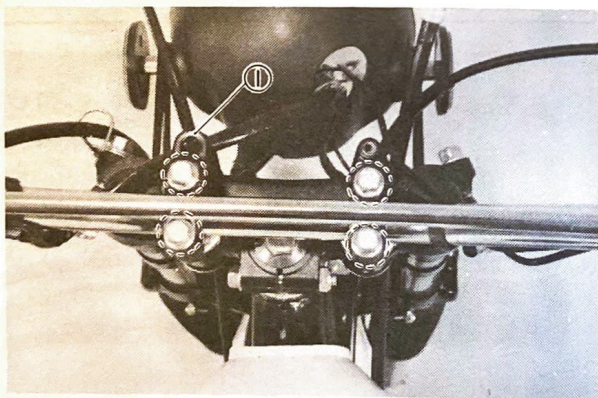

1. Wire guide

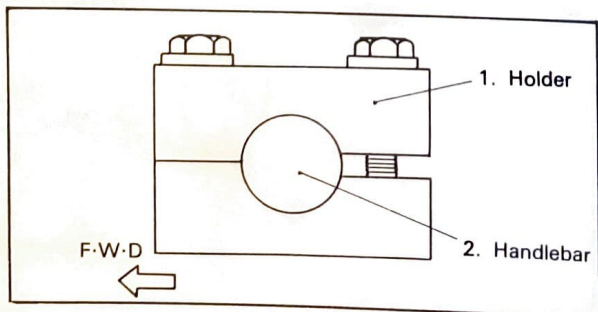

12. Install the meter assembly on the handle crown using bolts with washer.

NOTE:
 Before securing the meter bracket, all wires should be threaded through the headlight body. Take care not to kink wires by pressure.

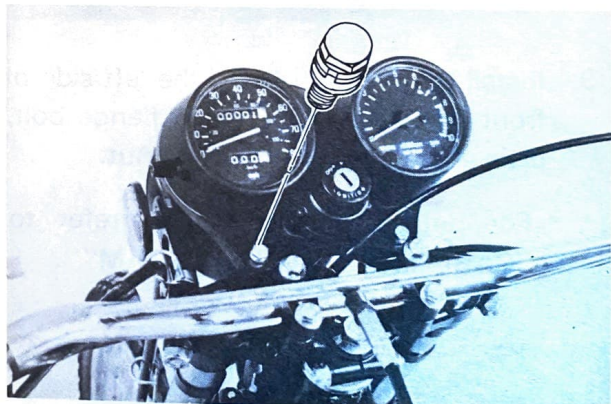

13. Connect the speedometer cable and tachometer cable to the speedometer and tachometer.

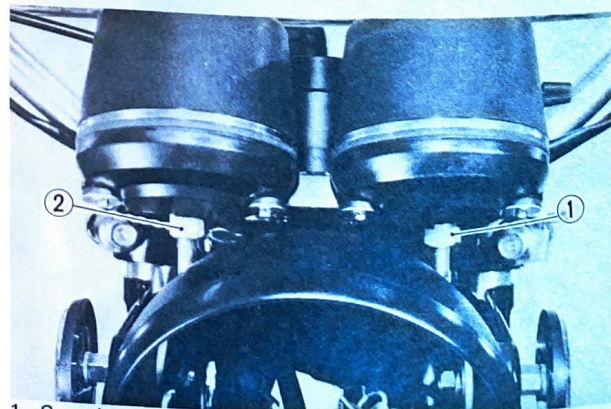

1. Speedometer cable 2. Tachometer cable

14. Brake wire and clutch wire installation
 - a. Screw in the cable length adjuster on the front brake shoe plate.
 - b. Fully loosen the lever adjuster lock nut, and screw in the adjuster until tight. Next, align the slit in the adjuster and adjuster lock nut with the slit in the lever holder.

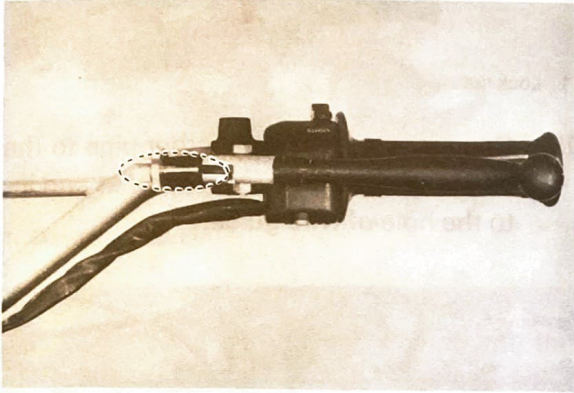

- c. Insert the wire end into the lever hole, and hook the outer cable end onto the adjuster lock nut, then squeeze the lever. Next, while pulling the outer cable in the direction opposite to the lever, release the lever quickly. While releasing it, seat the outer cable into the adjuster.

CAUTION:

Proper cable and wire routing is essential to insure safe vehicle operation. For details of the cable routing, refer to "CABLE ROUTING DIAGRAM".

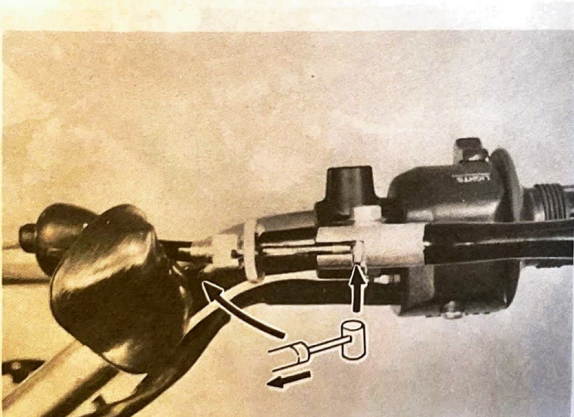

- d. Install the lever covers on clutch and brake wires.

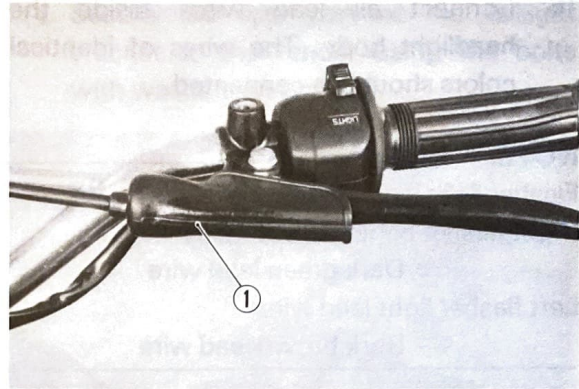

1. Lever cover

15. Front flasher light installation
 - a. Install the flasher stays on the handlebar.
 - b. Install both right and left front flasher lights to flasher stays of handlebar and tighten the nuts.

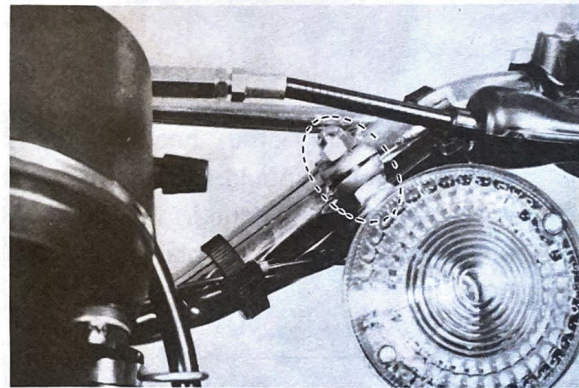

- c. Hold the light lead wire to the handlebar with a rubber band, and insert the lead wire end into the headlight body.

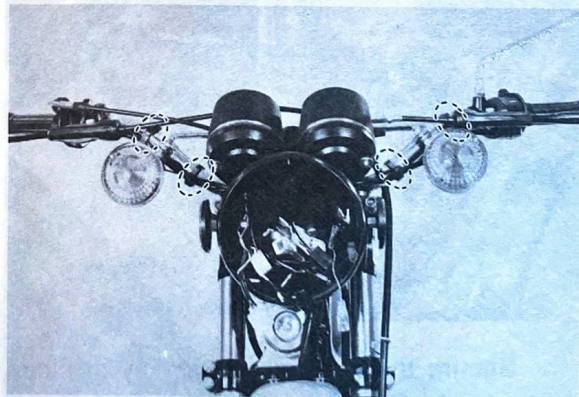

16. Connect all lead wires inside the headlight body. The wires of identical colors should be connected.

NOTE:

Flasher light lead wires are excluded.

Right flasher light lead wire

⇔ Dark green lead wire

Left flasher light lead wire

⇔ Dark brown lead wire

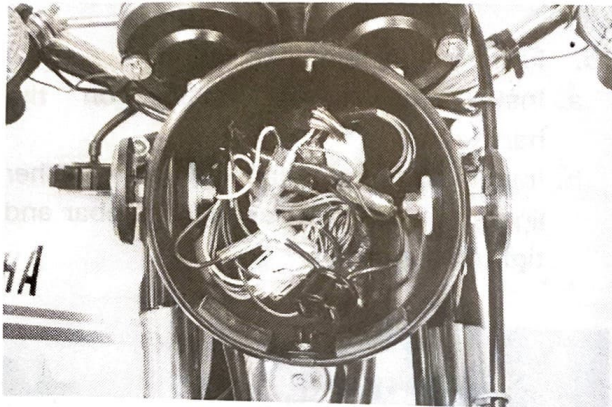

17. When installing the headlight lens assembly, care should be used so that wires are not pinched. Secure the headlight assembly in place with the bolt.

NOTE:

Fit the hole in the headlight unit assembly over the projection of the headlight body.

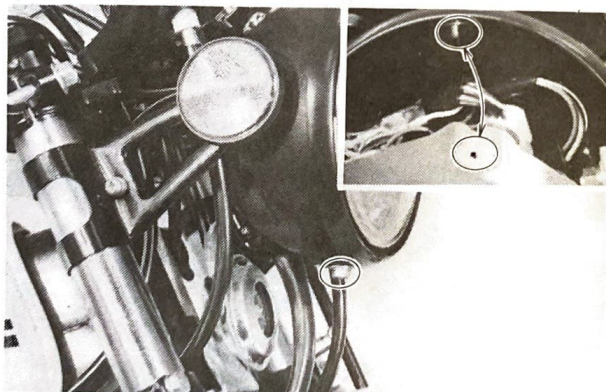

Secure the headlight assembly in place with the bolt.

18. Install the rear view mirror on the clutch lever holder (lefthand side), and tighten the lock nut.

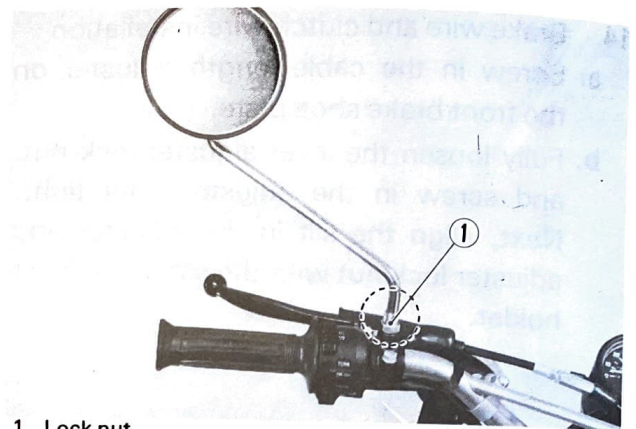

1. Lock nut

19. Connect one end of breather pipe to the fuel tank cap and insert the other end into the hole of wire guide.

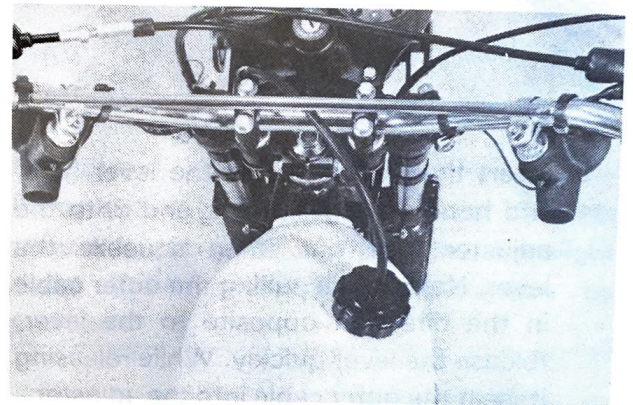

20. Install the footrest assembly to right side of the frame. Tighten the securing nut.

Tightening torque:
6.0 m·kg (42 ft·lb)

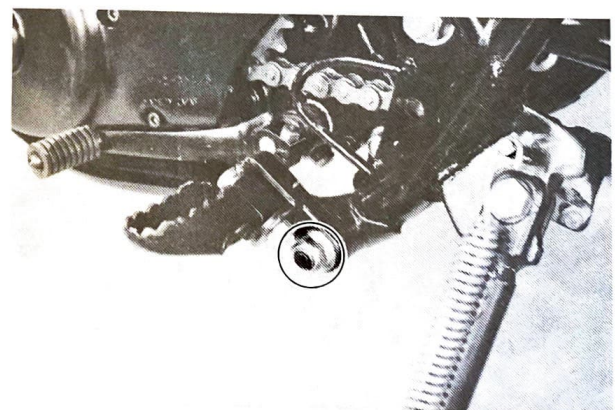

21. Taillight assembly installation

- a. Install the dampers and collars on the taillight bracket.

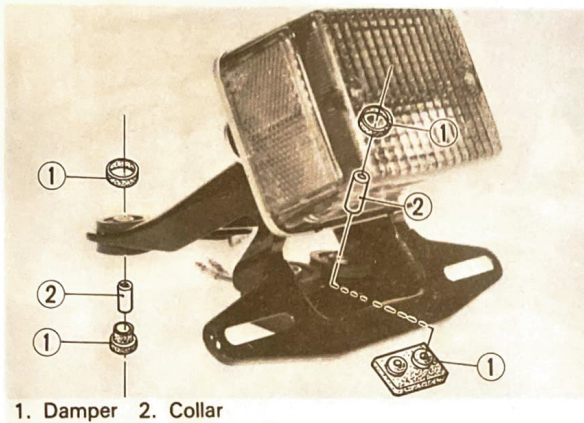

- b. Connect the taillight assembly lead wire to the wire harness, and lock it with the hook. (The wires of identical color should be connected.)

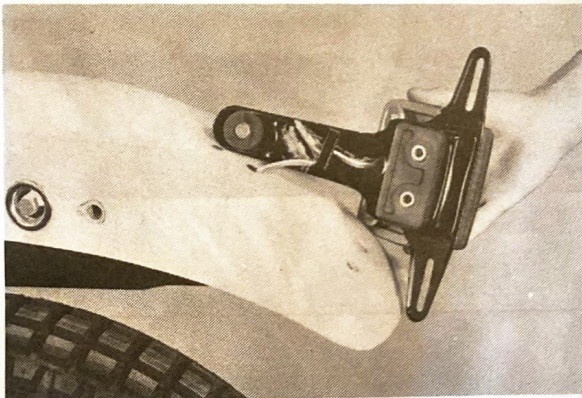

- c. Secure the front part of the taillight bracket to the rear fender using the plate washer, bolt with washer and crown nut.

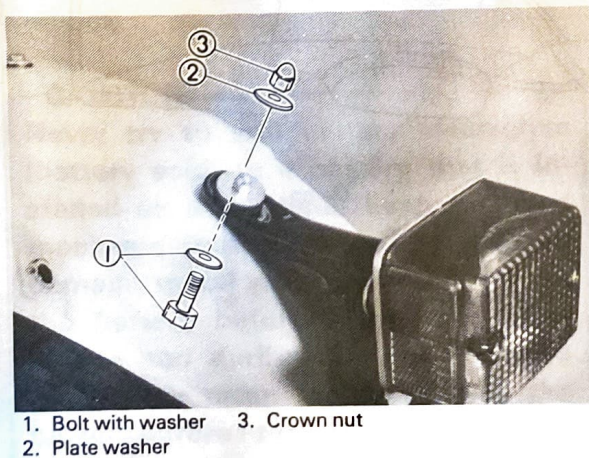

- d. Secure the rear part of the taillight bracket to the fender using the bolts with washers and nuts.

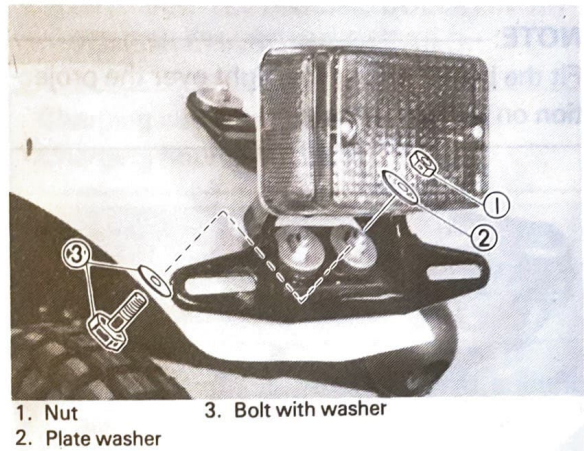

22. Install the license plate to the taillight assembly.

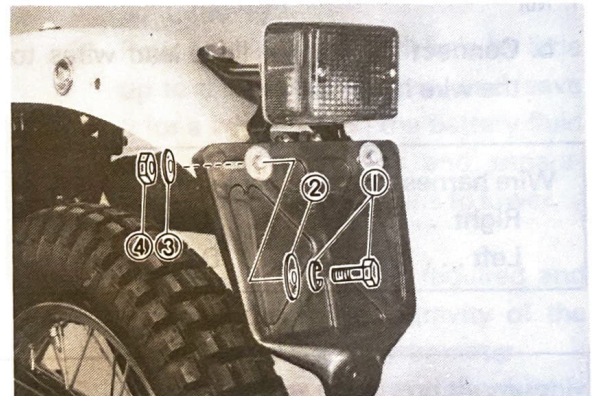

1. Bolt with washer 2. Plate washer
3. Plate washer 4. Nut

23. Install the rear reflector to the licence bracket.

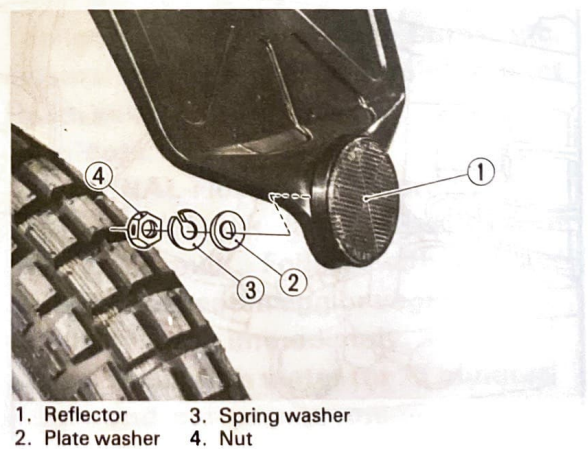

1. Reflector 2. Plate washer
3. Spring washer 4. Nut

24. Rear flasher light installation.
- Install the left and right flasher lights using the U-nuts.

NOTE:

Fit the hole in the flasher light over the projection on the flasher collar.

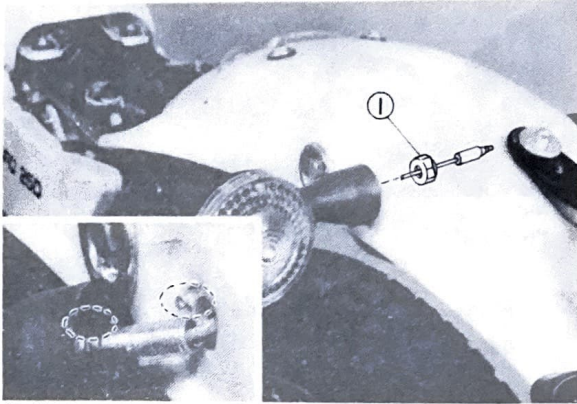

1. Nut

- Connect the flasher light lead wires to the wire harness.

Wire harness lead wire color:
 Right Dark green
 Left Dark brown

- After connecting wires, secure the lead wires with the clamp located inside the rear fender.

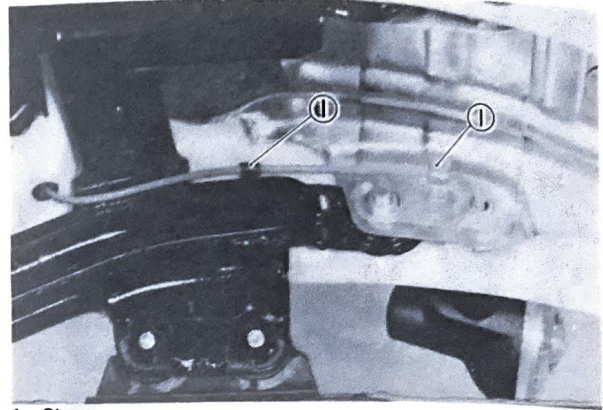

1. Clamp

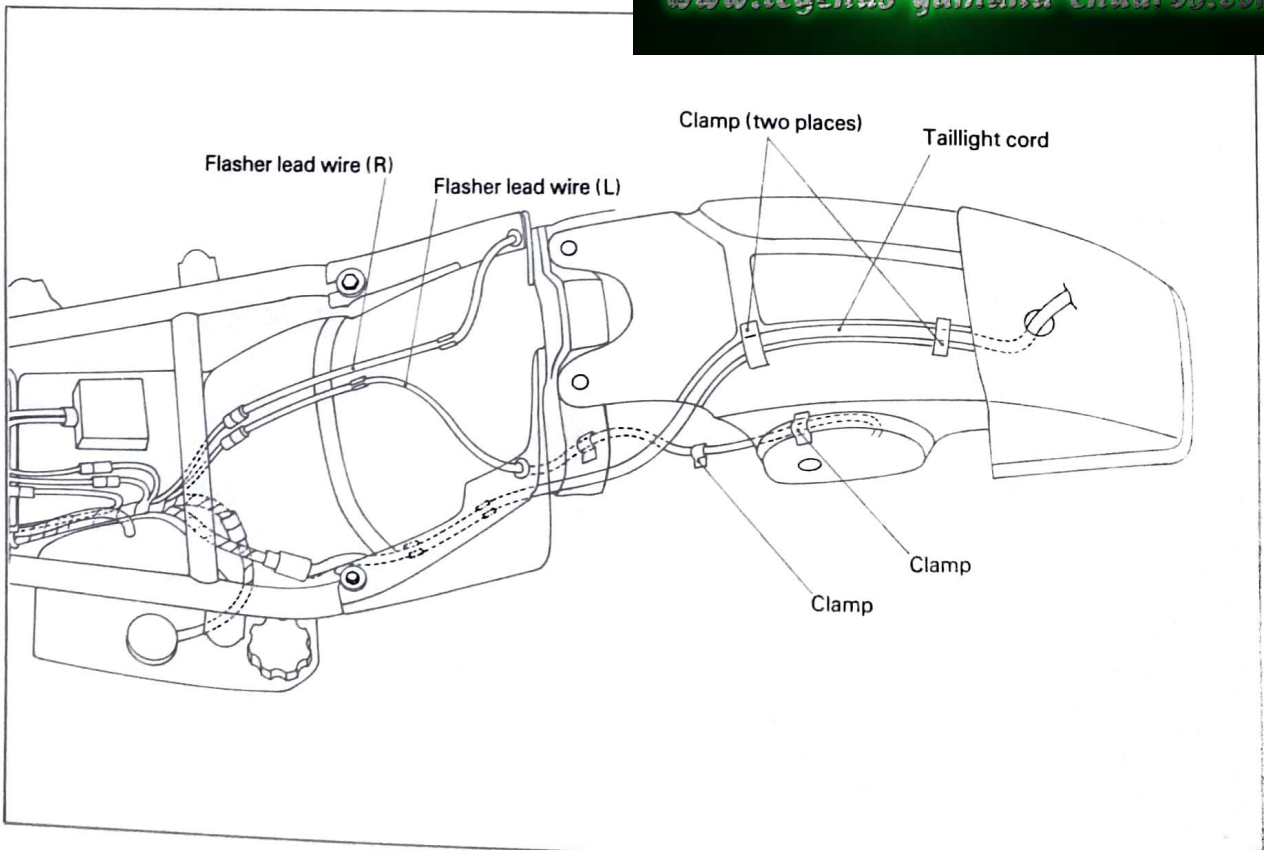
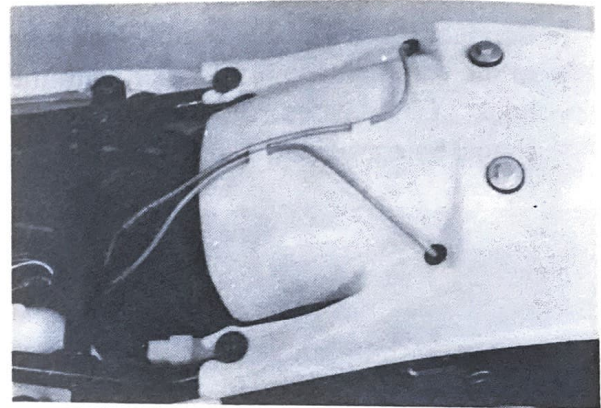

25. Tool kit installation

- a. Rotate the key hole cover on the side cover door and insert the key (main switch key) into the key hole.

Release the lock, by turning about 1/4 turn clockwise.

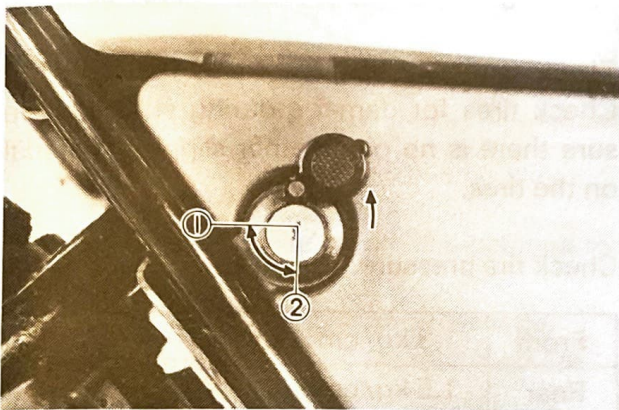

1. Open 2. Lock

- b. Install the tool kit in the tool box and secure the tool kit with a band.

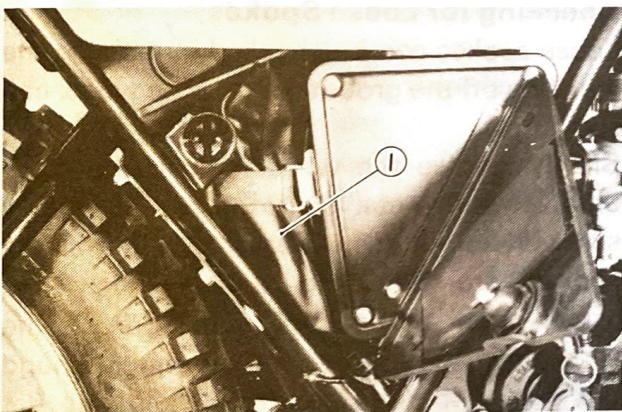

1. Tool kit

- c. Lock the side cover door.

26. Battery

- a. Remove the battery from the battery box.

CAUTION:

Never try to add battery electrolyte (battery acid) to a battery that is installed on a machine. Even a skilled mechanic will spill enough acid to damage metal parts. Always remove the battery before filling with electrolyte and during charging. Always completely clean the exterior of the battery before re-installing.

- b. The battery must be charged properly before using for the first time. This initial charge will prolong the life of the battery. SEE TECHNICAL BULLETIN M7-075 FOR CHARGING DETAILS.

Charging current: 0.6A

Charging hours: 10 hrs

- c. Electrolyte specific gravity

Specific gravity at 20°C (68°F): 1.260

- d. Filling the battery with diluted sulfuric acid (electrolyte).

- 1) Remove all filler caps from the battery, and remove the breather pipe cap at the same time.
- 2) Cool the electrolyte down to below 30°C (80°F).
- 3) Pour acid into each cell little by little up to the upper level line, and leave it for a while. When the battery fluid permeates the plates and separators, the fluid level begins to lower. Add electrolyte again.
- 4) Charge the battery as required and measure the specific gravity of the fluid. Use a battery hydrometer.
- 5) Install the filler caps, and thoroughly wipe off the fluid around the filler caps. Wipe off the battery completely before installation.

WARNING:

Battery fluid is poisonous and dangerous, causing severe burns, etc. Contains sulfuric acid. Avoid contact with skin, eyes or clothing.

Antidote:

EXTERNAL-Flush with water.

INTERNAL-Drink large quantities of water or milk. Follow with milk of magnesia, beaten egg or vegetable oil. Call physician immediately.

Eyes: Flush with water for 15 minutes and get prompt medical attention.

Batteries produce explosive gases. Keep sparks, flame, cigarettes, etc.

away. Ventilate when charging or using in enclosed space. Always shield eyes when working near batteries. **KEEP OUT OF REACH OF CHILDREN.**

27. Battery installation

- a. Make sure the main switch is turned off, and install the battery in the battery box.
 - Connect the positive lead wire first, and then connect the negative lead wire.

CAUTION:

Make sure battery leads are connected properly. Reversing leads can seriously damage the electrical system.

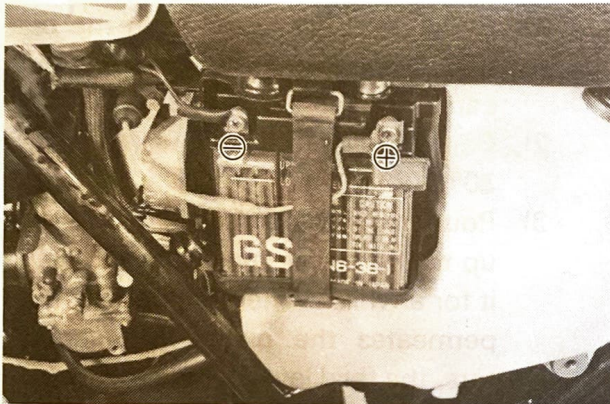

- b. The breather pipe should be connected as illustrated.

NOTE:

Rout the breather pipe outlet down and away from any part of the machine.

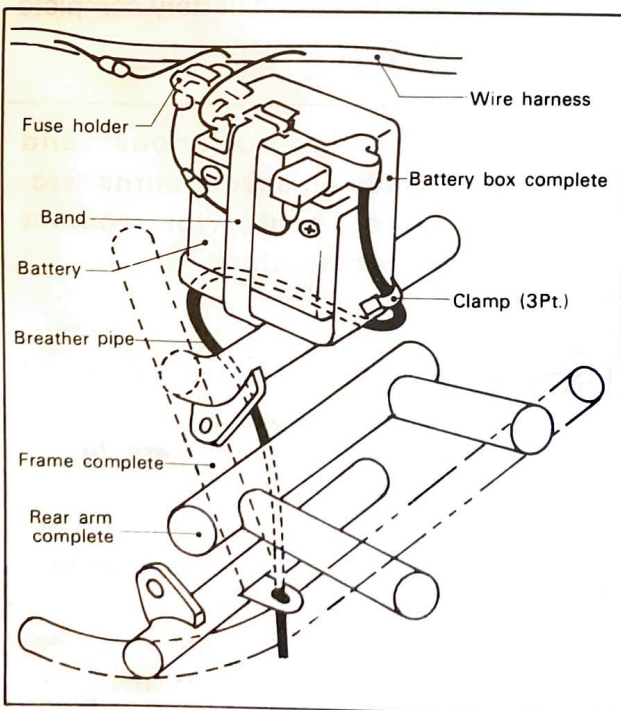

ADJUSTMENT...PRE DELIVERY SERVICE

The following adjustment must be made before delivery of the motorcycle to a customer. Use the checklist to mark off each operation when it is complete.

Pads of checklist (sets of 50) are available at no charge from YPDI P/N LIT-11161-00-78.

Tires

Check tires for damage during shipping. Be sure there is no oil or other slipping material on the tires.

Check tire pressure:

Front	1.3 kg/cm ²	Normal riding
Rear	1.5 kg/cm ²	
Front	1.5 kg/cm ²	High speed riding or with passenger
Rear	1.8 kg/cm ²	

Checking for Loose Spokes

Loose spokes can be checked by bracing the machine off the ground so that the wheel can spin freely.

Slowly revolve the wheel and at the same time let the metal shaft of a fairly heavy screwdriver bounce off each spoke. If all the spokes are tightened approximately the same, then the sound given off by the screwdriver hitting the spokes should sound the same. If one spoke makes a dull flat sound, then check it for looseness. It is also a good idea to check all spokes with a spoke wrench, so that they can be tightened immediately.

Fuel petcock and hose

1. Clean the petcock interior
 - a. Turn the fuel petcock to "OFF" position, and remove both filter cup and screen.
 - b. Clean the filter cup and screen with a solvent.
 - c. Re-install the cup and screen.
 - d. If dust collects or rust develops excessively in the filter cup, clean the inside of the tank with the solvent.



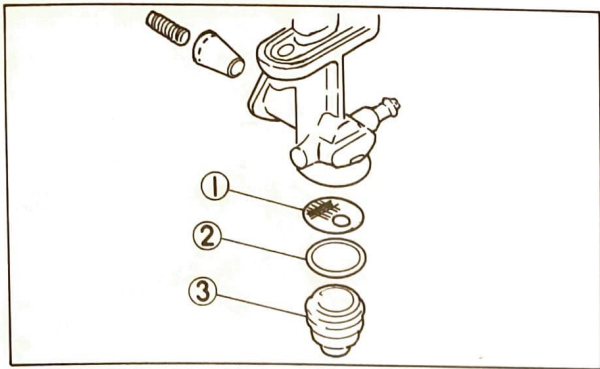

1. Filter screen 2. Gasket 3. Filter cup

2. Fuel hose

Check the fuel hose from the petcock to carburetor.

- a. Visually check for cracks or damage.
- b. If any defect is found, replace the hose.

Carburetor (throttle opening) adjustment

- a. Remove the bolt from the throttle opening adjusting port of carburetor, and fully turn the throttle grip out.
- b. Adjust the mark on the throttle slide in carburetor as illustrated.
 - 1) Loosen the lock nut.
 - 2) By turning the adjuster in or out, adjust throttle slide to the marked position.
 - 3) Tighten the lock nut.

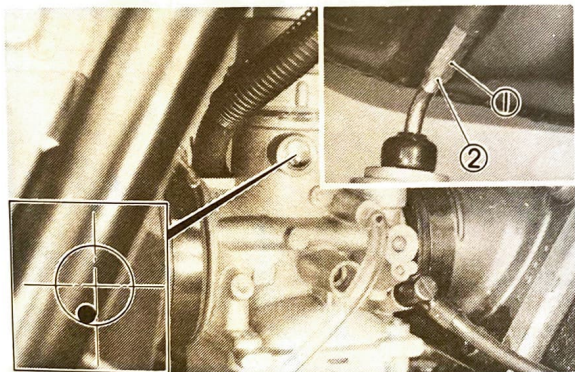

1. Adjuster 2. Lock nut

- c. Turn the throttle grip in once, and fully open it again. With the throttle grip in this position, check the position of throttle slide.
- d. Install the bolt and tighten.

NOTE:

During this operation, take care so that no dust enters the carburetor.

Throttle cable adjustment

Check play in turning direction of throttle grip. The free play should be 5 ~ 7 mm (0.2 ~ 0.28 in) at grip flange. Loosen the lock nut and turn the wire adjuster to make the necessary adjustment. Be sure to tighten the lock nut properly.

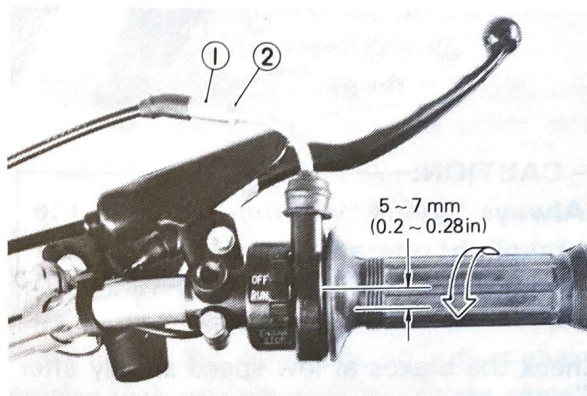

1. Adjuster 2. Lock nut

Front brake adjustment

Front brake should be adjusted to suit rider preference with a minimum cable slack of 5 ~ 8 mm (0.2 ~ 0.32 in) play at the brake lever pivot point.

- 1. Loosen the adjuster lock nut.
- 2. Turn the cable length adjuster in or out until adjustment is suitable.
- 3. Tighten the adjuster lock nut.

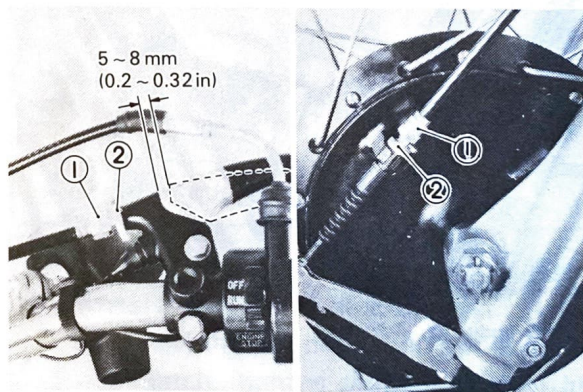

1. Adjuster 2. Lock nut

Rear brake adjustment

The rear brake should be adjusted so the end of the brake pedal moves 20 ~ 30 mm (0.8 ~ 1.2 in). To adjust, turn the adjuster on the brake rod clockwise to reduce play; turn the adjuster counterclockwise to increase play.

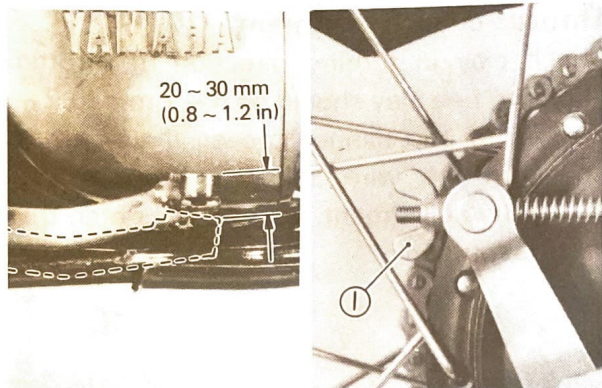

1. Adjuster

CAUTION:

Always check whether or not the brakelight operates correctly after rear brake adjustment.

Check the brakes at low speed shortly after starting out.

Brakelight switch adjustment

The brakelight switch is operated by movement of the brake pedal. To adjust, hold the main body of the switch so it does not rotate and turn the adjuster. Proper adjustment is achieved when the brakelight illuminates slightly before the brake starts to take effect.

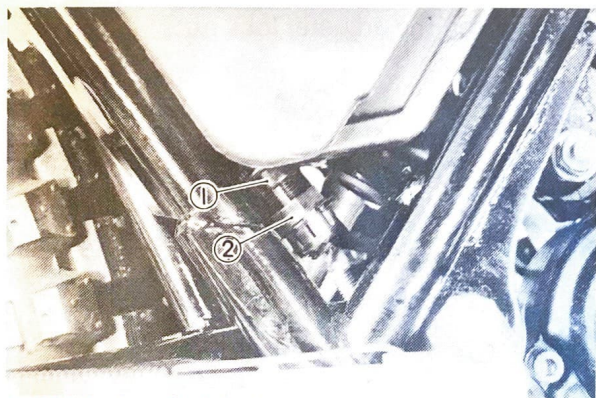

1. Main body 2. Adjuster

Clutch adjustment

Clutch should be adjusted to suit rider preference with a minimum cable slack of 2 ~ 3 mm (0.08 ~ 0.12 in) play at the clutch lever pivot point.

1. Loosen the adjuster lock nut.
2. Turn the cable length adjuster in or out until adjustment is suitable.
3. Tighten the adjuster lock nut.

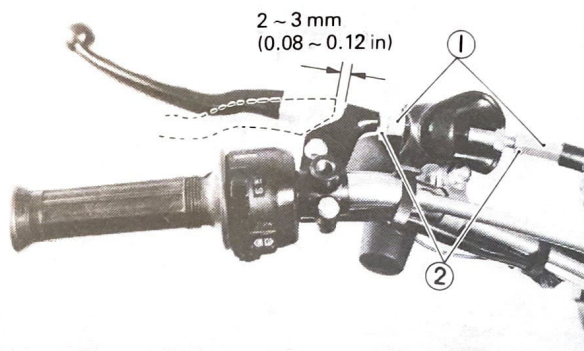

1. Adjuster 2. Lock nut

Engine and Transmission oil

1. Engine oil

We recommend the Yamalube 2-cycle oil. If for any reason you should use another type, use a 2-cycle engine oil labeled "BIA certified for service TC-W".

2. Transmission oil

To check level, start the engine and let it run for several minutes to warm and distribute oil. With the engine stopped, remove the oil filler cap. Set the dip stick on the case threads in a level position. Remove and check level.

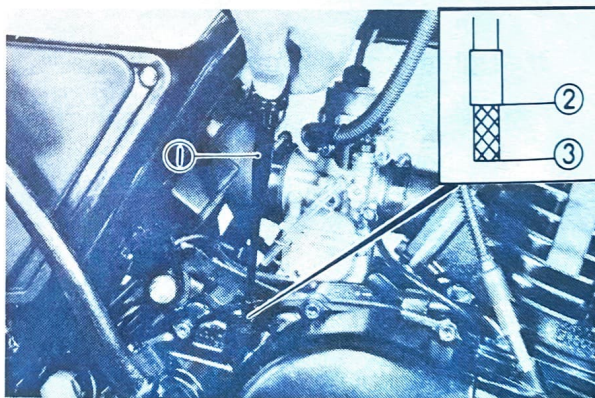

1. Oil filler cap 2. Maximum level 3. Minimum level

NOTE:

Be sure the machine is level and on both wheels.

The stick has Minimum and Maximum marks. The oil level should be between the two. Top up as required.

Recommended oil:
Yamalube 4-cycle oil or SAE 10W/30 type "SE" motor oil or "GL" gear oil

A drain plug is located on the bottom of the crankcase. With the engine warm, remove the plug and drain oil. Re-install plug and add fresh oil.

Transmission oil quantity:

Total (dry): 1,200 cc (1.3 qt)

Exchange: 1,100 cc (1.2 qt)

Transmission drain plug torque:

2.5 m-kg (18 ft-lb)

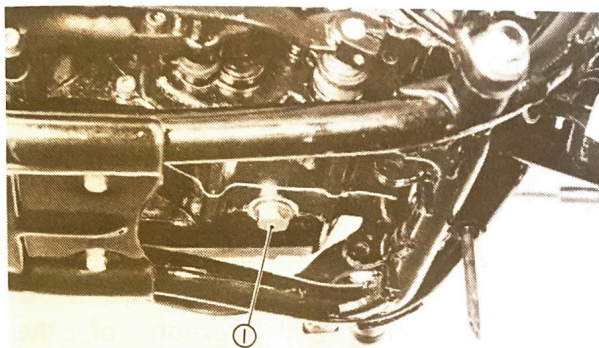

1. Drain plug

CAUTION:

Under no circumstances should any additives be included with the transmission oil. This oil also lubricates and cools the clutch. Additives may cause clutch slippage.

Drive chain adjustment

1. Tension check

Inspect the drive chain with both tires touching the ground. Check the tension at the position shown in the illustration. The normal vertical deflection is approximately 50 ~ 60 mm (1.97 ~ 2.36 in). If the deflection exceeds 60 mm (2.36 in) adjust the chain tension.



NOTE:

Tension inspection and adjustment should be made with the tensioner in the relaxed position (not touching the chain).

2. Tension adjustment

- a. Loosen the rear brake adjuster.
- b. Remove the rear axle cotter pin.
- c. Loosen the rear wheel axle nut.
- d. Turn chain puller both left and right, until axle is situated in same puller slot position.

NOTE:

Before adjusting, rotate rear wheel through several revolutions and check tension several times to find the tightest point. Adjust chain tension with rear wheel in this "tight chain" position.

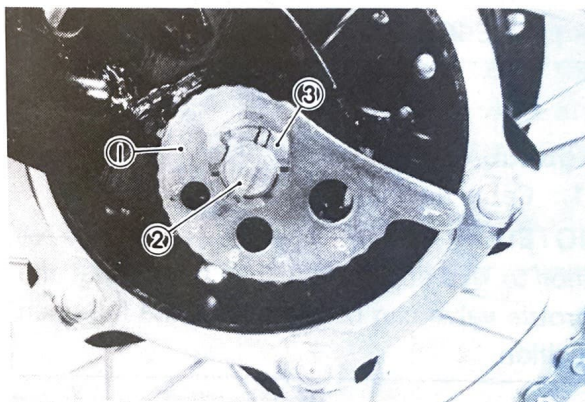

1. Chain puller 2. Cotter pin 3. Axle nut

- e. Tighten the rear axle nut.

Axle nut torque: 8.7 m-kg (62 ft-lb)

- f. Insert the new cotter pin into the rear wheel axle nut and bend the end of cotter pin. If the nut notch and pin hole do not match, tighten the nut slightly to match.

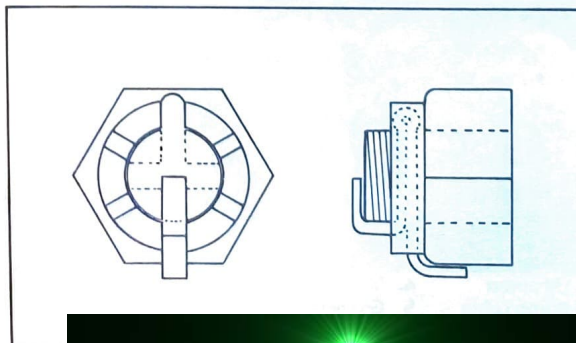

- g. In the final step, adjust the play in the brake pedal.

CAUTION:

Do not over tighten the chain. Excessive chain tension will overload the engine and other vital parts; keep the tension within the specified limits. Also, replace the rear axle cotter pin with a new one.

Drive chain lubrication

Apply lubricant between roller and side plates on both inside and outside of chain. Don't skip a portion as this will cause uneven wear. Apply thoroughly. Wipe off excess.

Recommended lubricant:
Yamaha Chain and Cable Lube or SAE 10W/30 motor oil

Autolube pump

1. Cable freeplay

NOTE:

Prior to this adjustment, make sure that the throttle valve can be opened to the full-open position.

- a. Fully open the throttle grip, and adjust the pump cable so that the mark on the pump adjusting pulley aligns with the adjusting pulley guide pin.

Pulley mark:

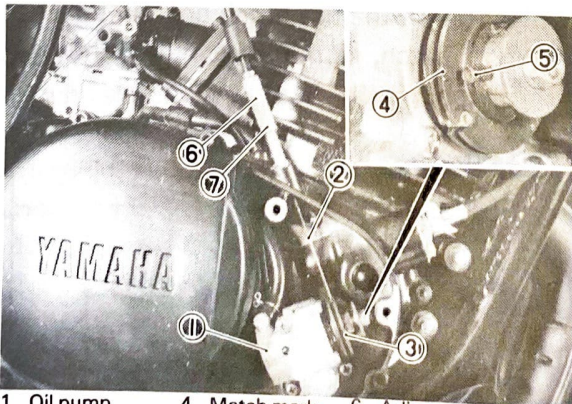

1. Oil pump
2. Pump cable
3. Adjust pulley
4. Match mark
5. Guide pin
6. Adjuster
7. Luck nut

- b. If the mark and pin are not in alignment, loosen the cable length adjuster lock nut on top of crankcase cover and adjust cable length until alignment is achieved. Tighten adjuster lock nut.
- c. Back off the throttle grip once, and fully open it again. Make sure that the pump cable is correctly adjusted.

2. Air bleeding

The Autolube Pump and delivery lines must be bled on the following occasions:

- Setting up a new machine out of the crate.
- Whenever the Autolube tank has run dry.
- Whenever any portion of the Autolube system is disconnected.
- If the machine lies on its side after falling over.

a. Bleeding the pump case and/or oil pipe

- 1) Remove the bleed screw.

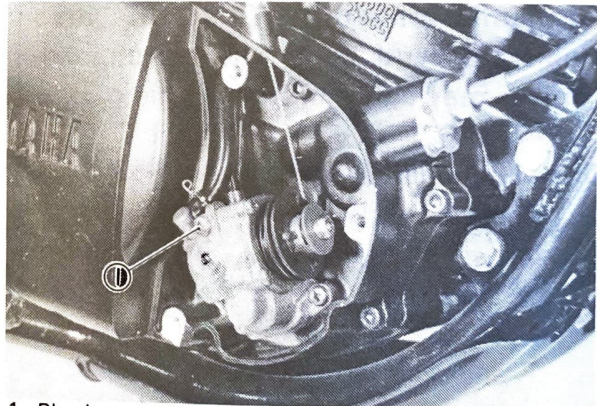

1. Bleed screw

- 2) Keep the oil running out until air bubbles disappear.

NOTE:

Check the bleed screw gasket, and if damaged, replace with a new one.



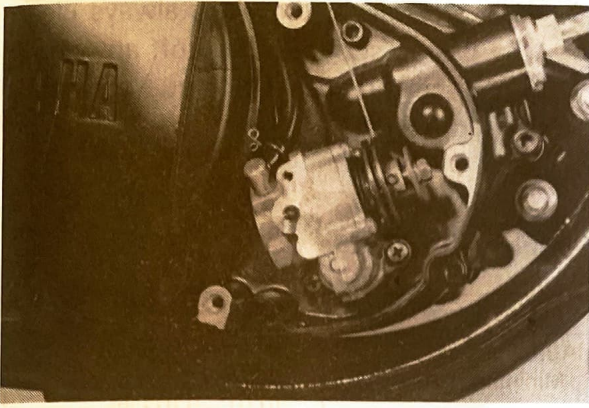

3) When air bubbles are expelled completely, tighten the bleed screw and install the pump cover.

b. Bleeding the pump distributor and/or delivery pipe

- 1) Start the engine.
- 2) Pull the pump wire all the way out to set the pump stroke to a maximum.

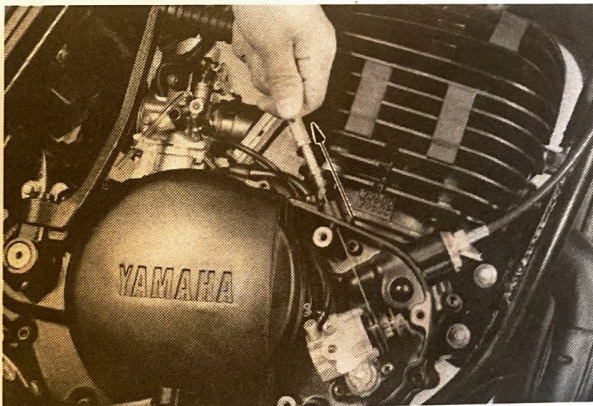

NOTE:

It is difficult to bleed the distributor completely with the pump stroke at a minimum, and therefore the pump stroke should be set to a maximum.

- 3) Keep the engine running at about 2,000 r/min for two minutes or so, and both distributor and delivery pipe can be completely bled.

Ignition timing

1. Ignition timing is checked with timing light by observing the position of the stationary pointer marked on the crankcase and the marks on the magneto flywheel.
2. Checking the ignition timing
Using a timing light, the stationary pointer and mark (center mark) on the magneto flywheel, adjust the ignition timing correctly.
 - a. Remove the crankcase cover left.
 - b. Connect the timing light to the spark plug lead wire.
 - c. Start the engine and keep it running at the specified speed.

Specified speed: 4,000 r/min

- d. While running the engine at the specified speed, check to see that the stationary pointer is aligned with the magneto center mark. If the marks are out of alignment, follow the steps below.

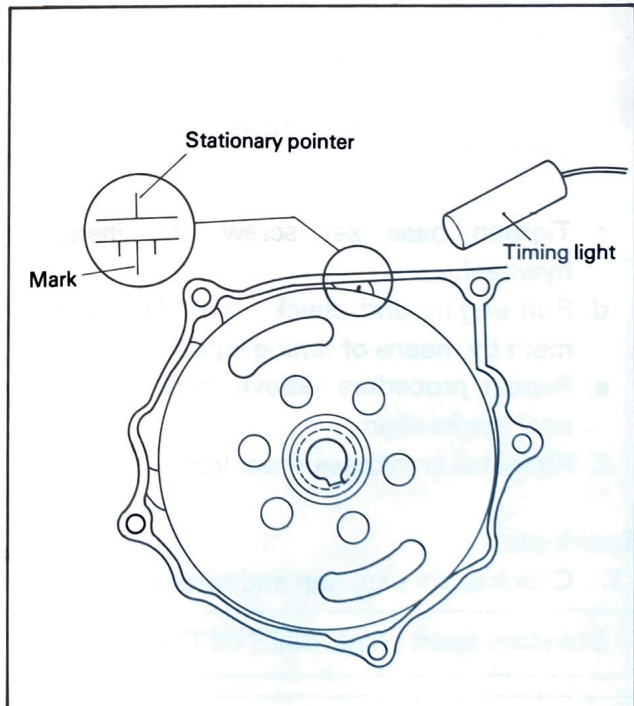

3. Adjusting the ignition timing
 - a. Remove the flywheel using magneto holder and magneto puller.

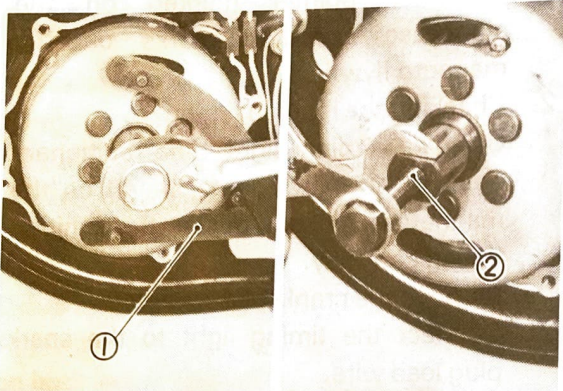

1. Magneto holding tool 2. Flywheel puller

- b. Loosen base set screws and turn base until the stationary pointer and the mark on the base align.

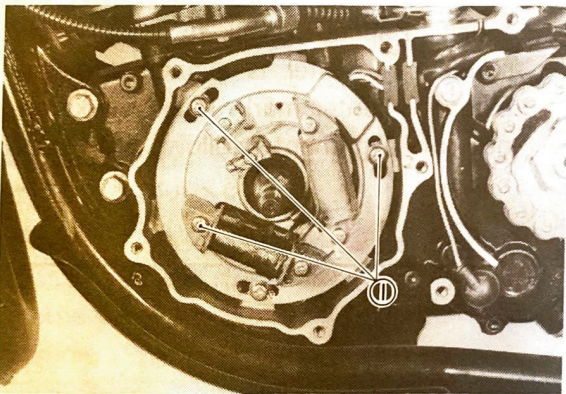

1. Base set screws

- c. Tighten base set screw and install flywheel.
 - d. Run engine and check marks for alignment by means of timing light.
 - e. Repeat procedure (above steps 2, b-d) until marks align.
 - f. Re-install crankcase cover left.

Spark plug

1. Check spark plug gap and torque.

Standard spark plug: B8ES (N.G.K.)

Spark gap:
0.7 ~ 0.9 mm (0.028 ~ 0.035 in)

Spark plug torque: 2.5 m·kg (18 ft·lb)

2. When installing the plug, always clean the gasket surface. Wipe off any grime from the threads and torque the spark plug properly.

Specification Table

Engine idling speed	1,000 ~ 1,200 r/min
Autolube pump: Minimum stroke	0.25 ~ 0.30 mm (0.01 ~ 0.012 in)
Adjusting mark Oil tank capacity	☒ (at full throttle) 1.1 lit (1.04 US qt)
Front fork oil	257 cc (15.7 cu. in)
Fuel tank capacity	8.5 lit (2.2 US qt)

www.legends-yamaha-enduros.com

www.legends-yamaha-enduros.com



YAMAHA MOTOR CO.,LTD.

IWATA, JAPAN

PRINTED IN JAPAN
78 - 10 - 2.13 x 10