

# YAMAHA

## ENDURO

# DT125C

## OWNER'S MANUAL

[www.legends-yamaha-enduros.com](http://www.legends-yamaha-enduros.com)

560-28199-10

## INTRODUCTION

Thank you for buying the Yamaha DT125C.

This model is the product of many years of Yamaha experience and strict Yamaha quality control. The resultant ease of handling, high performance and reliability promise you full pride of ownership.

This manual is written in such a way as to provide the owner with a good understanding of the features, operation, maintenance and inspection of this vehicle. All information required for safe and reliable use of the vehicle is contained in this manual, so read it carefully and completely before operating the vehicle. If you have any questions concerning the information, ask your dealer before operating the vehicle.

### NOTICE:

---

Some data in this manual may become outdated due to improvements made to the machine in the future. If there is any question concerning this manual, consult your nearby Yamaha dealer.

---

# CONTENTS

FEATURES .....	1
NOMENCLATURE .....	3
MACHINE IDENTIFICATION .....	4
CONTROL FUNCTIONS .....	5
PRE-OPERATION CHECK .....	15
OPERATION AND IMPORTANT DRIVING POINTS .....	18
PERIODIC MAINTENANCE AND MINOR REPAIR .....	25
REQUIREMENTS FOR A GOOD MOTORCYCLIST .....	65
CLEANING AND STORAGE .....	65
MISCELLANEOUS .....	68
WARRANTY INFORMATION .....	70

## **FEATURES**

**TORQUE INDUCTION.** Another new YAMAHA engine debut! The reed valve has been adopted as the induction system for the DT125C. This system, utilizing its unique 7-port construction, ensures excellent engine performance from low to high speed.

**YAMAHA AUTOLUBE.** Yamaha Autolube provides superior engine lubrication which extends service life.

**EASIER STARTING.** With the primary coupled starting system, the engine can be started in any gear simply by disengaging the clutch.

**ADJUSTABLE REAR SHOCKS.** The shocks are adjustable to five positions. This enables the rider to adjust spring tension to compensate for varying weights, speeds and road conditions.

**STARTER GENERATOR.** The starter generator starts the engine using the current from the battery. After starting the engine it operates as a generator and recharges the battery.

**FRONT FORKS.** The Yamaha DT125C employs a front fork design well known for its strength and superior handling characteristics. They assure the rider of ultimate response under all conditions.

**STARTER JET EQUIPPED CARBURETOR.** Equipped with this unique starter jet, the Yamaha DT125C is, quick starting under all conditions.

**EMERGENCY STOP SWITCH.** The engine can be stopped during any emergency by a quick flip of the switch.

**SPEEDOMETER AND TACHOMETER.** A speedometer and tachometer are standard equipment. The individual units are separately mounted for maximum visibility. An additional feature of the speedometer is an odometer which can be reset by tenths to zero for trip or enduro purposes.

**TIRES.** The Yamaha DT125C is fitted with Trials Universal tires as standard equipment. This particular tread is one of the most versatile available. It gives maximum trail traction, yet is compatible with road usage at moderate speeds.

# NOMENCLATURE

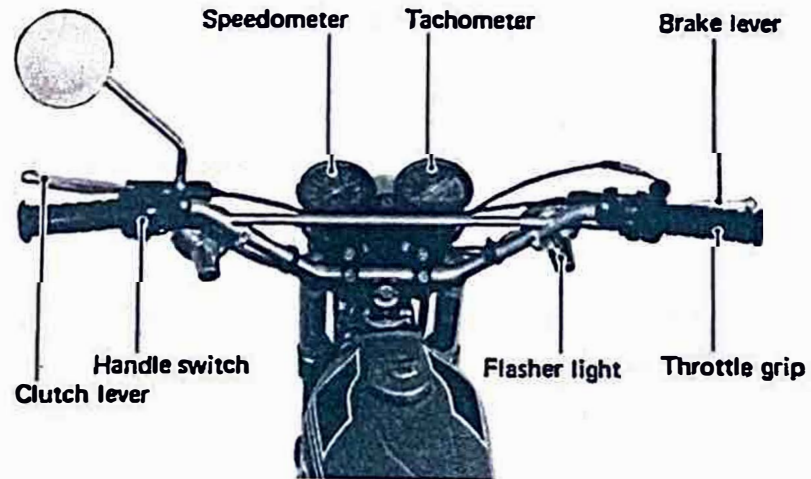
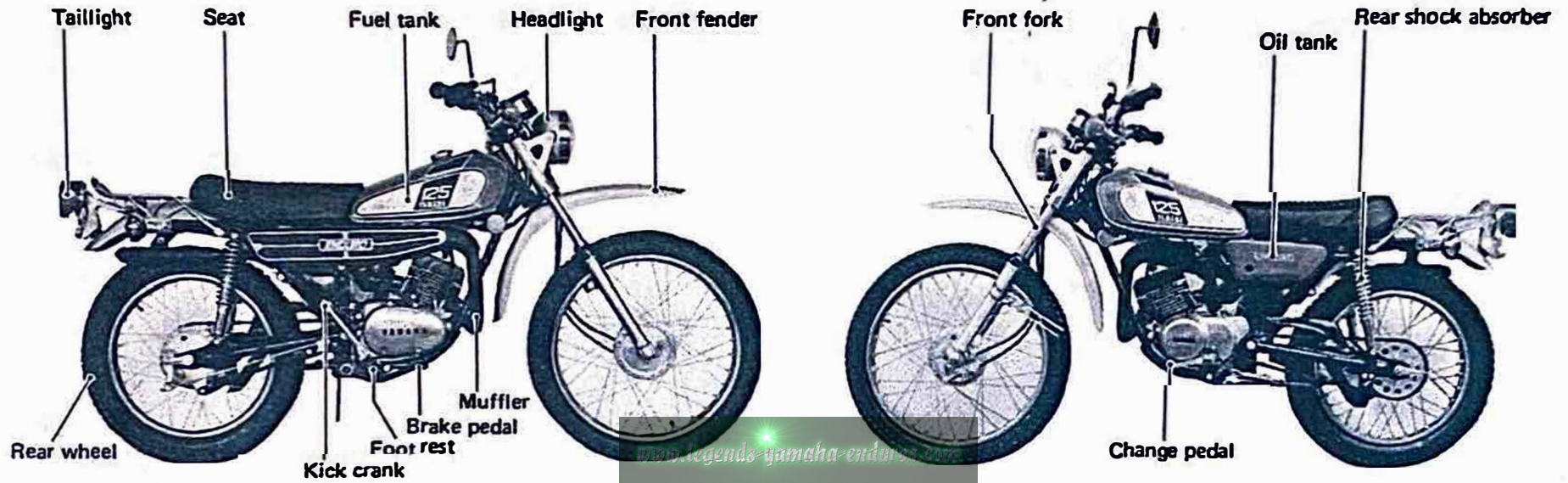

## MACHINE IDENTIFICATION

### Frame number

The frame number is stamped side of the steering head pipe

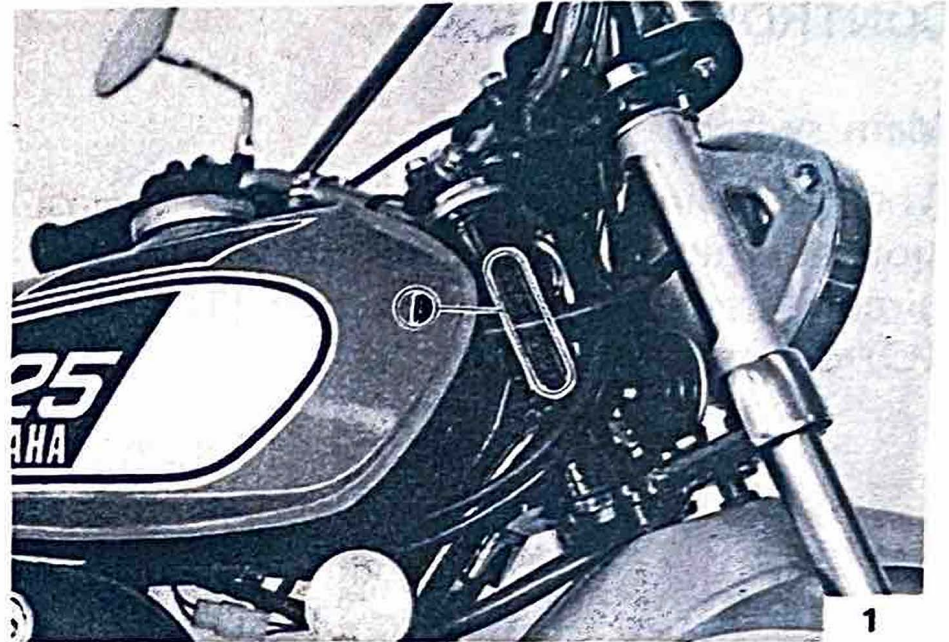

1. Frame number

### Engine number

The engine serial number is stamped into the elevated part of the left section of the engine.

**NOTE:** \_\_\_\_\_

The first three digits of these numbers are for model identifications; the remaining digits are the unit production number. The two serial numbers are usually identical but they may sometimes be 2 or 3 numbers apart.

---

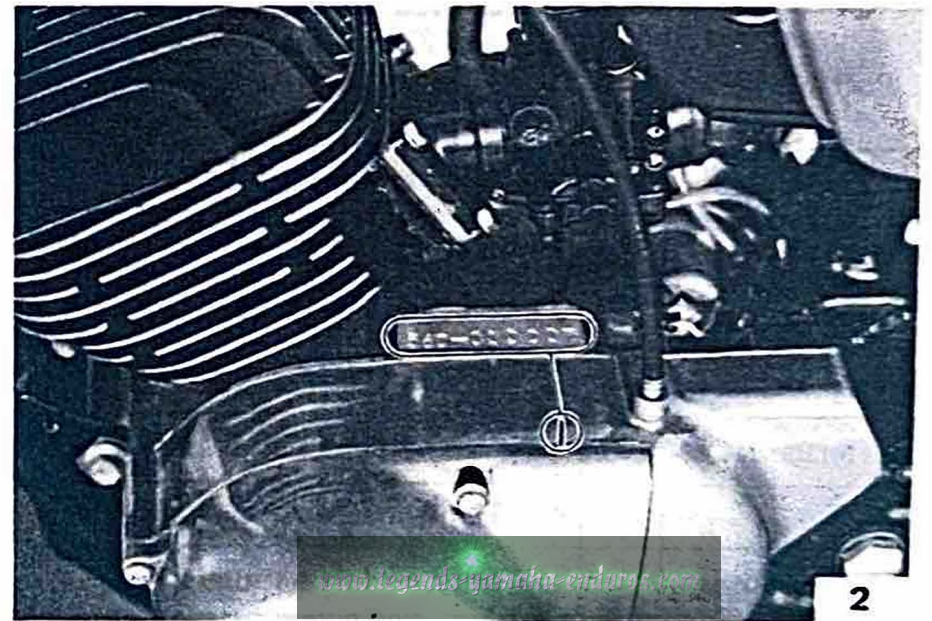

1. Engine number

# CONTROL FUNCTIONS

## Main switch

The following chart shows the key position at which the lamps, horn and ignition circuit are switched on or off: (The circle (O) denotes "Switch on".)

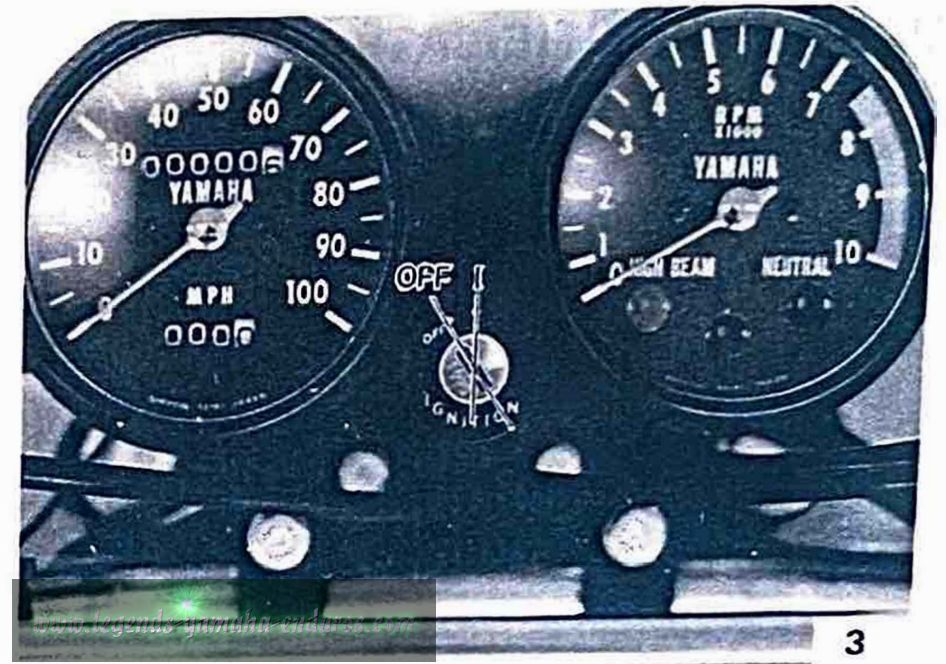

Part Name	Key Position		Instructions
	Off	I	
Ignition Circuit		○	Kick starting, or electric starting.
Headlamp		○	Turn on left handlebar switch.
Taillamp		○	Turn on left handlebar switch.
Stoplamp		○	The brake is applied.
Meterlamp		○	Turn on left handlebar switch.
Horn		○	The horn button is depressed.
Flasherlamps		○	Turn on left handlebar switch.



## Handle switches

The handle switches are located near the right and left handle grips and are used for the following functions:

### “ENGINE STOP” switch

Make sure that the engine stop switch is on “RUN”. The engine switch has been equipped to ensure safety in an emergency such as when the motorcycle is upset or trouble takes place in the throttle system.

The engine will not start when the engine switch is turned to “OFF”

### “START” switch

Press button to activate the starter. Take your finger off the button immediately after the engine starts.

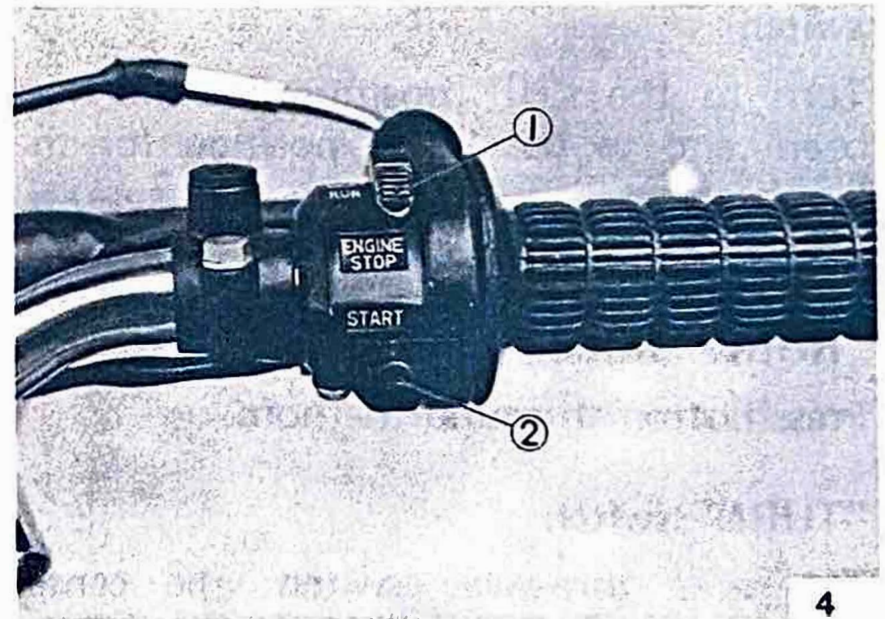

1. “ENGINE STOP” switch
2. “START” switch

## **“LIGHTS” switch A (Right side—Lighting switch)**

To light the headlamp, taillamp and meter lamps push the switch forward.

## **“LIGHTS” switch B (Left side—Dimmer switch)**

Turn to the “HI” position for the high beam and to the “LO” position for the low beam.

## **“HORN” switch**

Press button to sound the horn.

## **“TURN” switch**

This is a three-way switch: the center position is off: turn to the “L” position for the left flasher and to the “R” position for the right flasher.

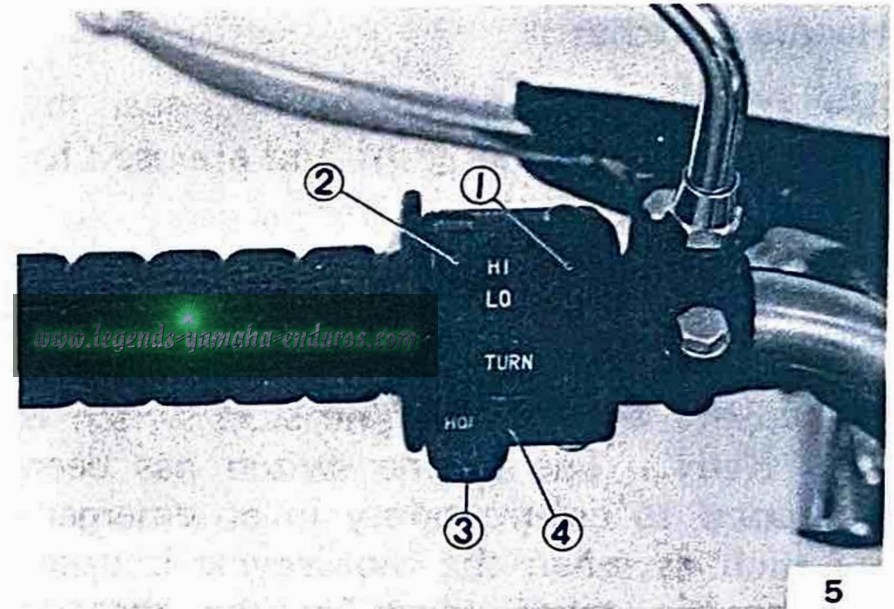

1. “LIGHTS” switch A
2. “LIGHTS” switch B
3. “HORN” switch
4. “TURN” switch

## Fuel petcock

The fuel petcocks function to supply fuel from the tank to the carburetor and also to filter the fuel.

The fuel petcocks have the following three positions:

**RES:** This indicates reserve. If you run out of fuel while driving, move the lever to this position. Then, fill the tank at the first opportunity.

**OFF:** With the lever in this position fuel will not flow. Return the lever to this position when the engine is not running.

**ON:** With the lever in this position fuel flows to the carburetor. Normal driving is done with the lever in this position.

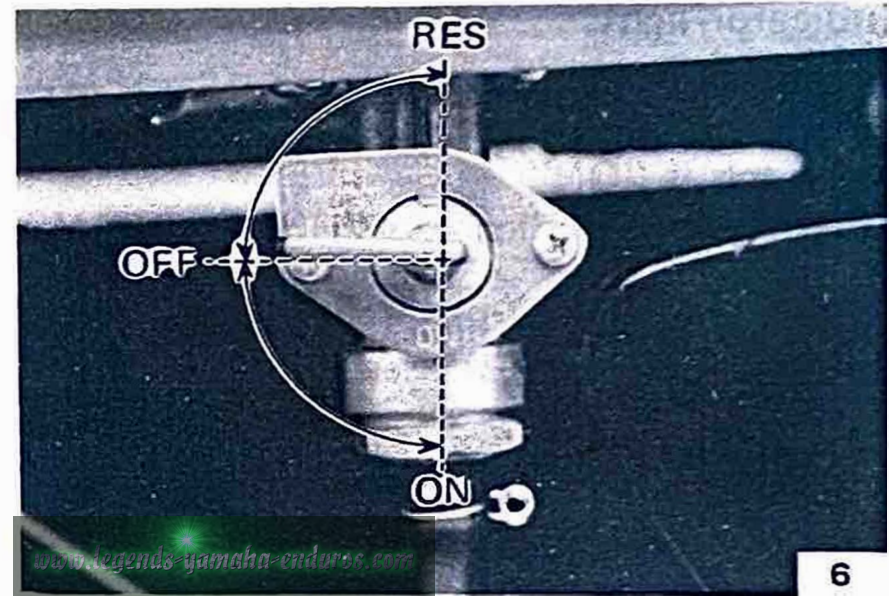

## Indicator lights

### Flasher pilot light (orange):

The pilot light flashes when the flasher switch is "ON".

### High beam indicator "HIGH BEAM" (blue):

This indicator lights when the headlight high beam is used.

### Neutral pilot light "NEUTRAL" (green):

Lights when transmission is in neutral.

## Front brake lever

The front brake lever is located on the right handle bar; pivot it toward the handlebar to activate the front brake.

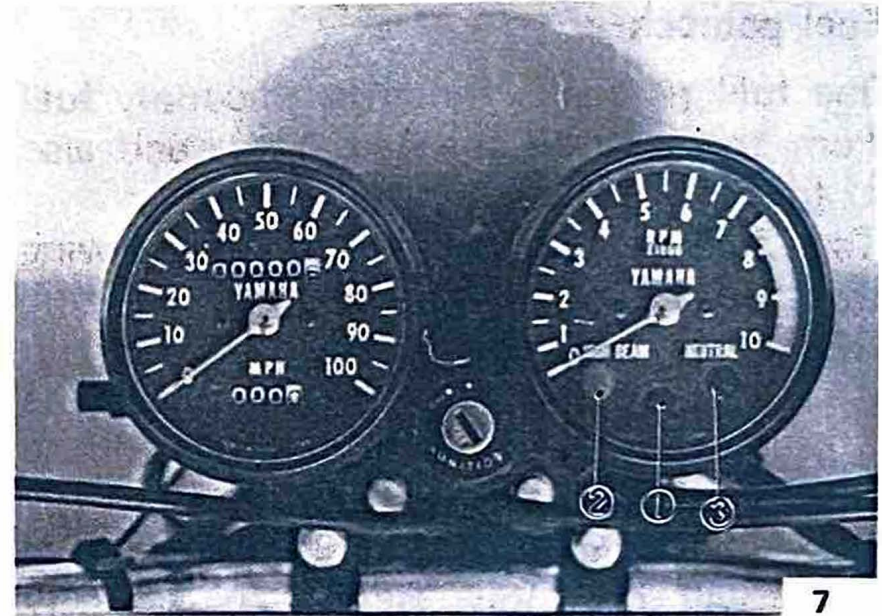

1. Flasher pilot light    2. High beam indicator  
3. Neutral pilot light

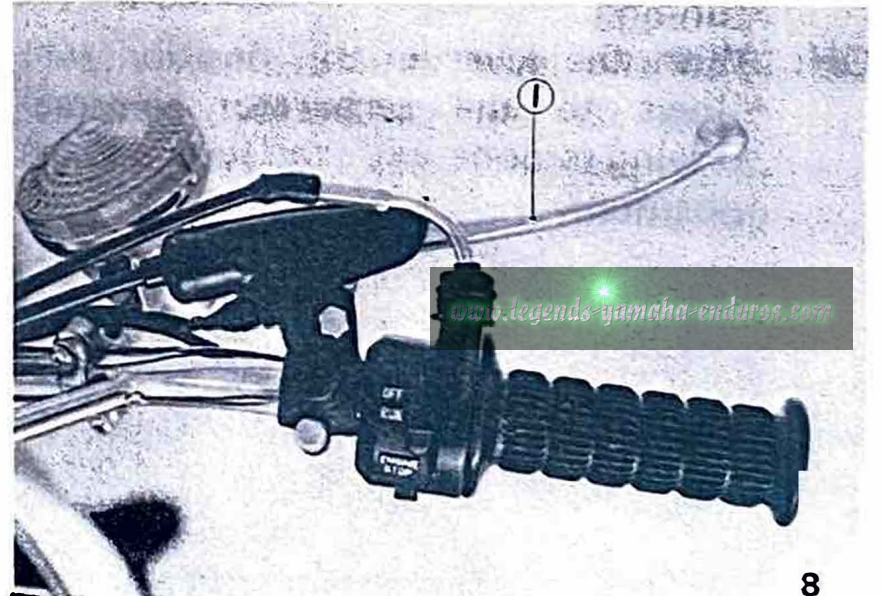

1. Front brake lever

## Rear brake pedal

The rear brake pedal is on the right side of the motorcycle and activates the rear brake through a link rod.

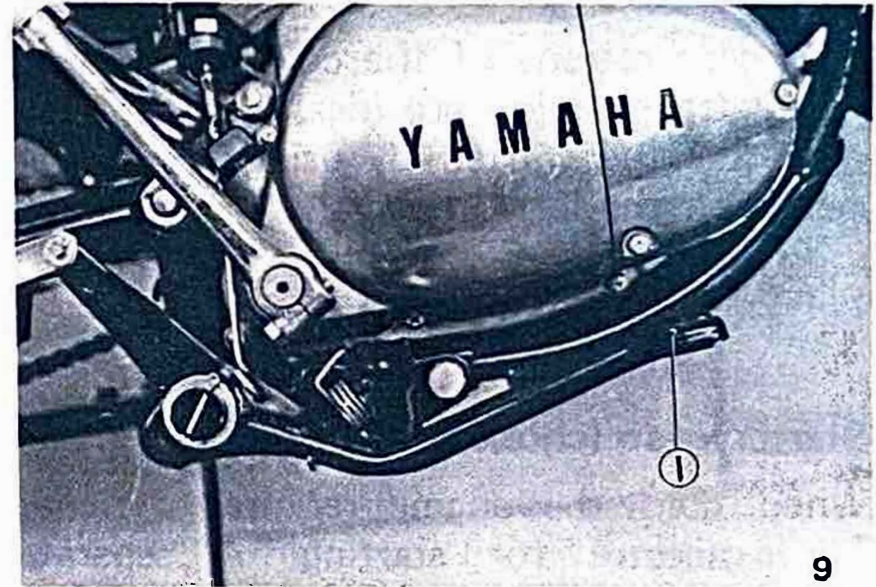

1. Rear brake pedal

## Clutch lever

The clutch lever is located on the left handlebar and disengages or engages the clutch. Pivot the clutch lever to the handlebar to disengage the clutch and release the lever to engage the clutch. The lever should be pulled rapidly and released slowly for smooth starts.

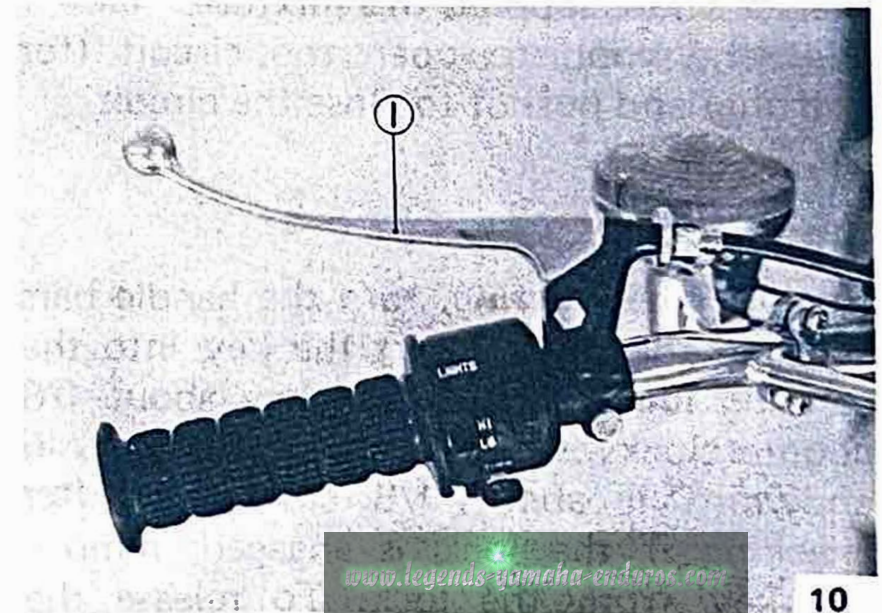

1. Clutch lever

## Gear shifting

The gear ratios of the constant mech 5 speed transmission are ideally spaced. The gears can be shifted by using the change pedal on the left side of the engine.

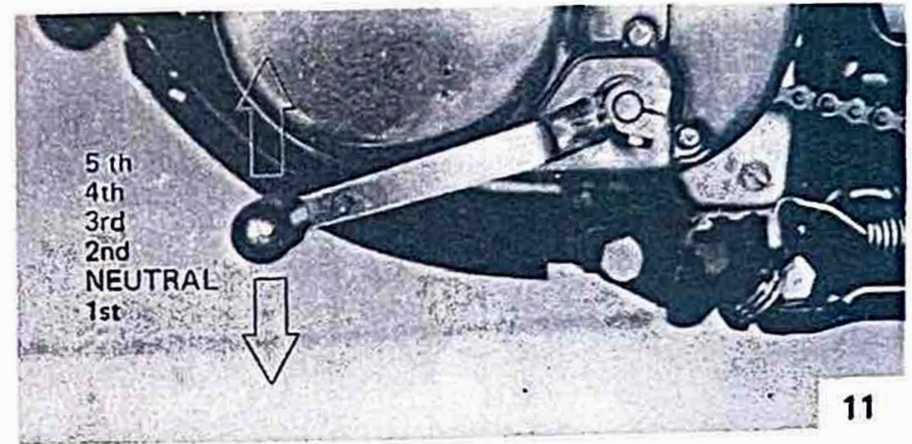

## Starter knob (choke knob)

When cold the engine requires a richer fuel mixture for starting. A separate starter circuit, which is controlled by the starter knob, supplies this mixture.

Pull the knob to open the circuit (for starting) and push it to close the circuit.

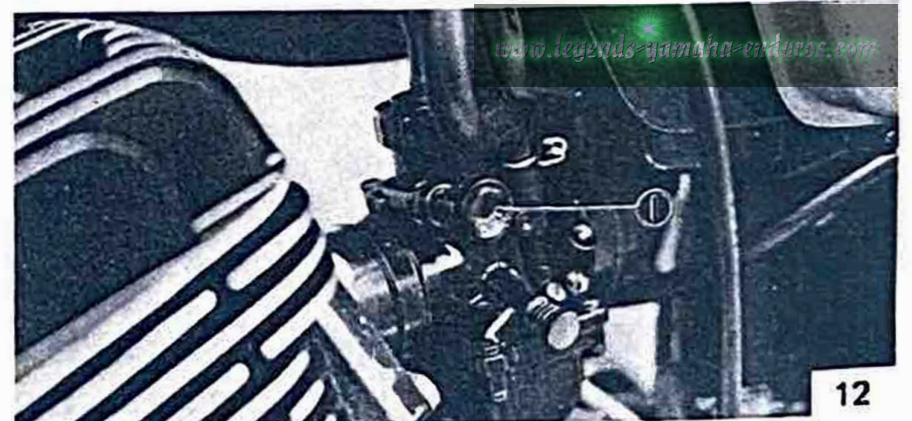

1. Starter knob

## Steering lock

To lock the steering, turn the handle bars fully to the right, insert the key into the steering lock and turn the key about 1/8 counterclockwise; then push the key in and turn it about 1/8 clockwise. After checking if the lock is engaged, remove the key from the lock. To release the lock, reverse the above steps.

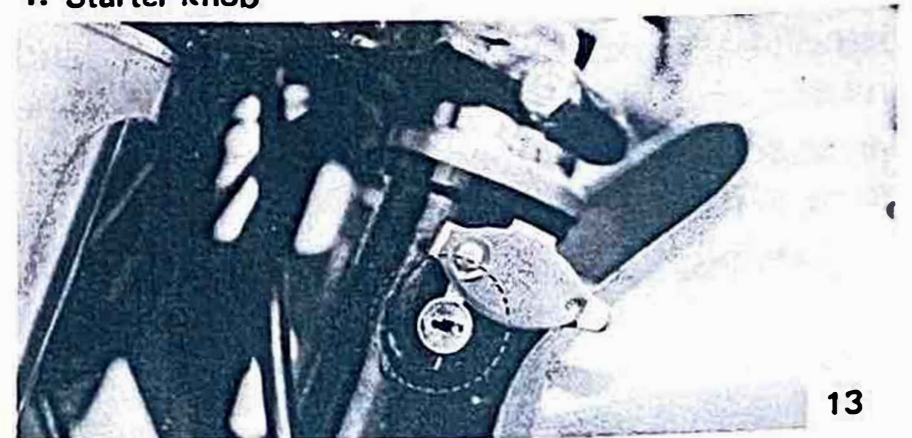

13

## Fuel tank cap

The locking fuel tank cap can be removed as follows:

Rotate the cover to one side, insert the key and turn it 1/4 counterclockwise. The cap can then be removed by turning counterclockwise and lifting. To relock the cap, set it in place and turn it clockwise. Then turn the key 1/4 clockwise, remove key and rotate the cover over the key-hole.

## Seat lock

To open the seat lock, insert the key in the lock and turn it clockwise.

To lock the seat, replace the seat in the original position.

## Helmet holder

To open the helmet holder, insert the key in the lock and turn it counterclockwise.

To lock the helmet holder, replace the holder in the original position.

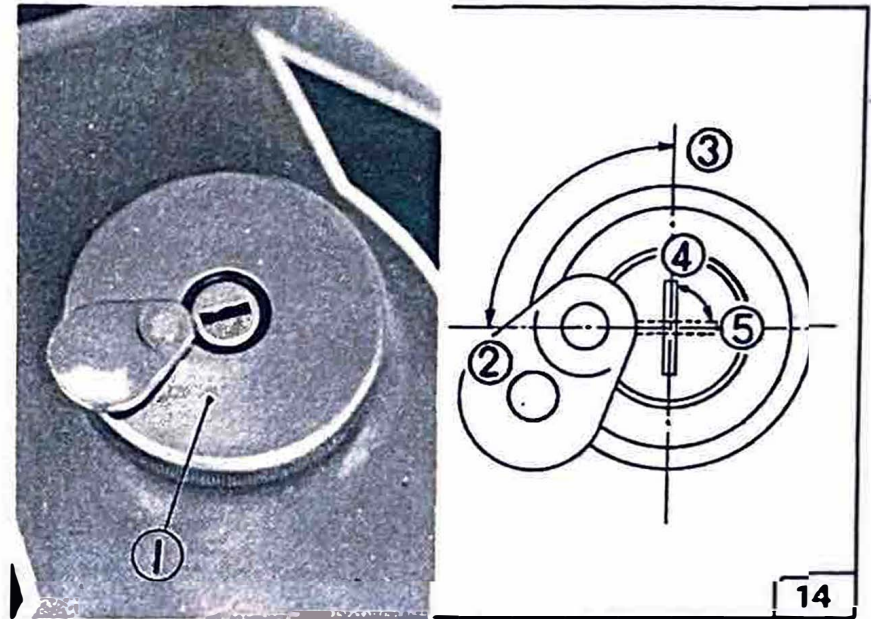

1. Tank filler cap
2. Open
3. Close
4. Unlock
5. Lock

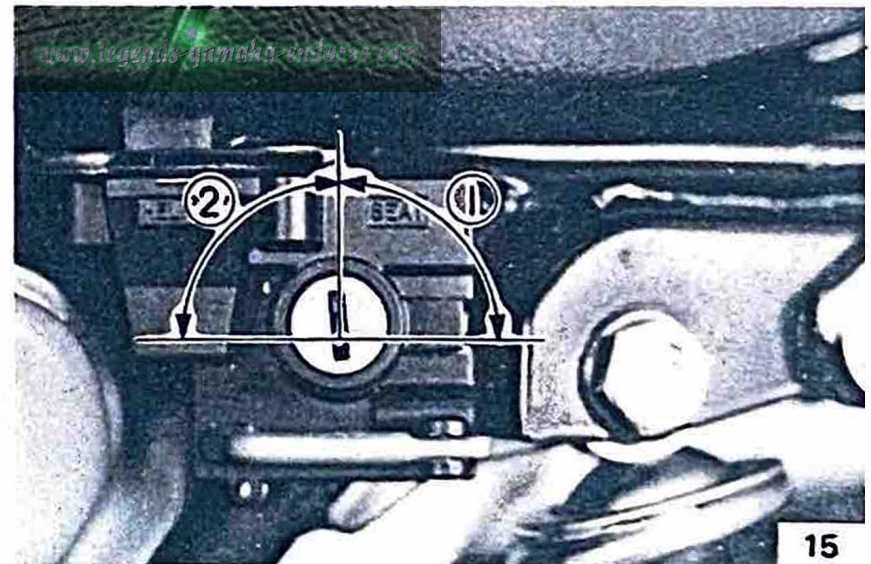

1. Seat lock open

2. Helmet holder open

## Tripmeter

A tripmeter is built into the speedometer shell. Pull out on knob and twist to reset by tenths to desired mileage. Push knob in afterwards.

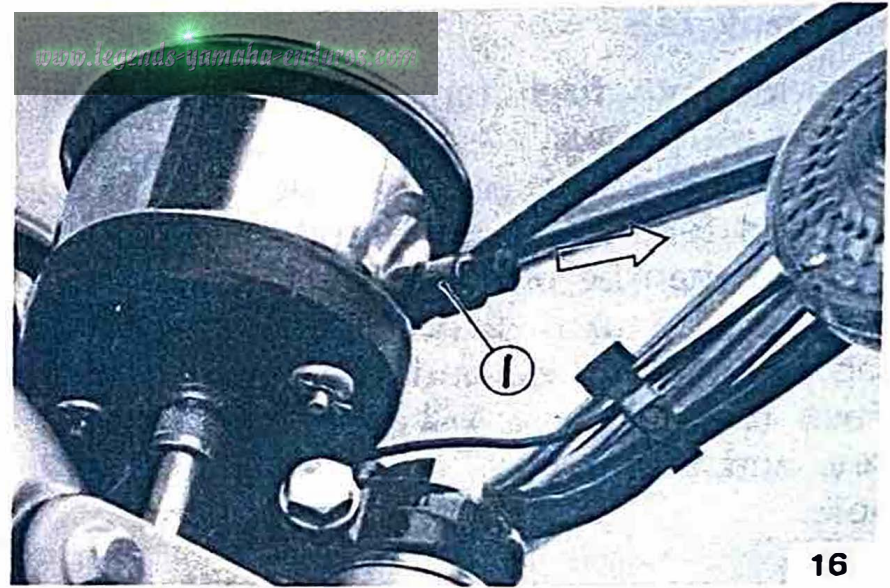

1. Tripmeter knob

16



## Tachometer

The tachometer is provided so the rider can keep engine rpms within the ideal power range.

The tachometer can be used as follows:

To obtain maximum performance, run the engine up to the recommended rpm range in each gear.

In this range, the engine performs with maximum efficiency and minimum wear. Never operate the engine outside the recommended range.

Recommended rpm range: 3,000 – 6,000 rpm
Do not operate in the red zone. Red zone: 7,500 – 10,000 rpm

## Kick starter

To start the engine, rotate the kick crank, push down lightly with foot until gears engage, and then kick with full strength. This model has the primary kick starter so the engine can be started in gear if the clutch is disengaged. As normal practice, however, shift to neutral before starting.

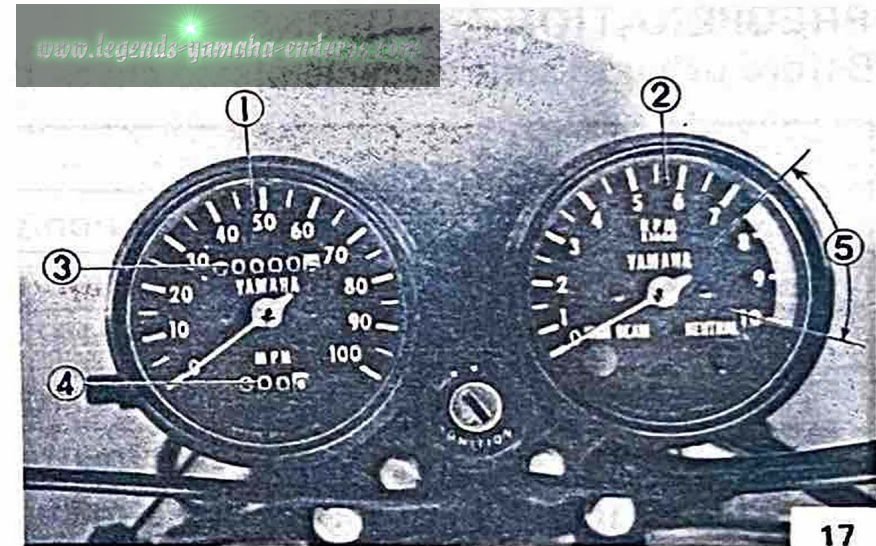

1. Speedometer
2. Tachometer
3. Odometer
4. Tripmeter
5. Red zone

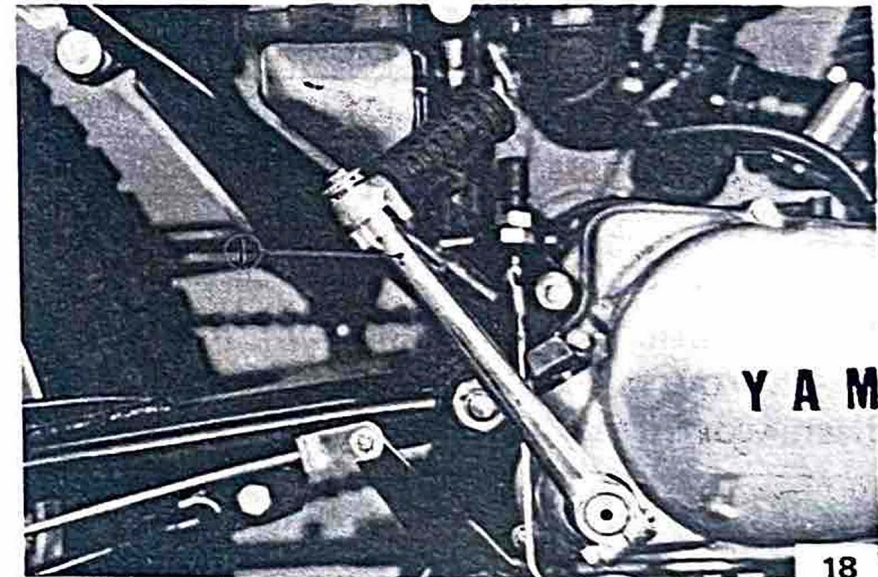

1. Kick crank

## PREOPERATION CHECKS

Before using this motorcycle please check the following points:

Item	Routine	Page
Brakes	Check operation/adjustment	17,45,46
Clutch	Check operation/lever adjustment	17,42,43
Autolube tank	Check oil level/top-off as required	16,30
Transmission	Check oil level/top-off as required	16,31,32
Drive chain	Check alignment/adjustment/lubrication	48,49,50
Spark plug(s)	After break-in check color/cond'n weekly	33,34
Throttle	Check for proper throttle and autolube cable operation	17,39
Air filter	Foam type – must be clean and damp w/oil always	35,36
Wheels and tires	Check pressure/runout/spoke tightness/axle nuts	16,54~61
Fittings/fasteners	Check all – tighten as necessary	—
Lights/signals	Check headlight/tail – stoplights/turn sigs., etc.	62,63

### NOTE:

Pre-operation checks should be made each time the machine is used. Such an inspection can be thoroughly accomplished in a very short time; and the added safety it assures is more than worth the time involved.

## Fuel

Make sure there is sufficient fuel in the tank.

Recommended gasoline: 90 octane
Fuel tank capacity: 1.8 U.S. gal. (7.0 lit)

## Engine oil

Make sure there is sufficient engine oil in the oil tank. Add oil as necessary.

Recommended oil:

See page 30, "Engine oil section"

Oil tank capacity: 1.3 U.S. qt. (1.2 lit)
----------------------------------------------

## Transmission oil

Make sure the transmission oil is at the specified level. Add oil as necessary.

Recommended oil: Yamalube 4-cycle or SAE 20W/40 type "SE" motor oil
Oil quantity: 0.8 qt. ( 750 cc)

## Tires

Check the tire pressure and check the tires for wear.

### Tire pressure

	Front tire	Rear tire
Off-road	14 lb/in <sup>2</sup> (1.0 kg/cm <sup>2</sup> )	17 lb/in <sup>2</sup> (1.2 kg/cm <sup>2</sup> )
On paved roads	24 lb/in <sup>2</sup> (1.7 kg/cm <sup>2</sup> )	28 lb/in <sup>2</sup> (2.0 kg/cm <sup>2</sup> )

If a tire tread shows cross wise lines, it means that the tire is worn to its limit. Replace the tire.

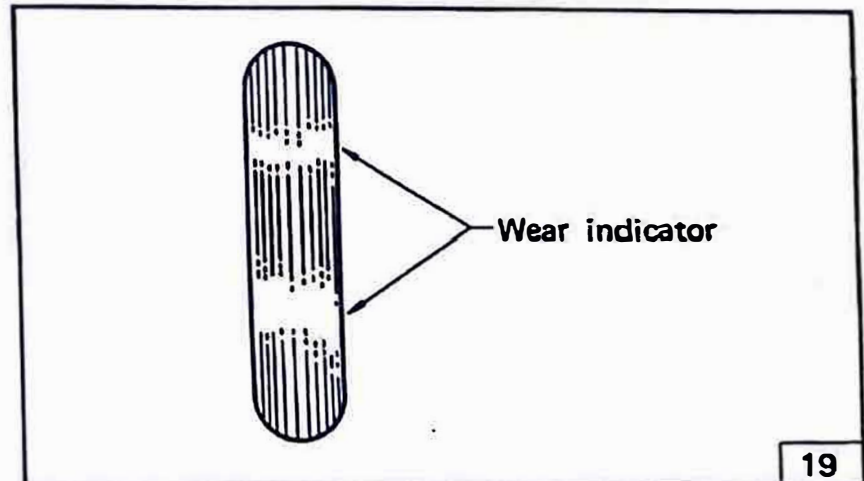

## **CAUTION:**\_\_\_\_\_

A great danger is apprehended from driving with a worn tire. When a tire tread begins to show lines, have your Yamaha dealer replace the tire immediately.

---

### **Brake lever and brake pedal**

Check for correct play in the brake lever and pedal and make sure they are working properly. Check the brakes at low speed shortly after starting out.

### **Lights and signals**

Check the headlight, flasher lights, tail-light, stoplight, meter lights, and all the indicator lights to make sure they are in working condition.

### **Clutch lever**

Check for correct play in the clutch lever and make sure the lever operates properly.

### **Speedometer and tachometer**

Check for proper operation.

### **Switches**

Check the operation of the "LIGHTS" switches, the "TURN" switch, stoplight switch, "HORN" switch, "START" switch, main switch, etc.

### **Throttle grip**

Turn the throttle grip to see if it operates properly and if the play is normal. Make certain the throttle springs closed when released.

## OPERATION AND IMPORTANT DRIVING POINTS

### CAUTION: \_\_\_\_\_

Before riding this motorcycle, become thoroughly familiar with all operating controls and their function.

Consult your Yamaha dealer regarding any control or function you do not thoroughly understand.

---

### Starting a cold engine

1. Turn the fuel petcock to "ON".
2. Turn the ignition key to the "I" position and turn the engine stop switch to the "RUN" position.
3. Operate the carburetor starter jet (choke) knob and completely close the throttle grip.
4. Kick the kick crank with full strength or press the "START" switch to start the engine.

5. After the engine starts, warm up for one or two minutes. Make sure the starter jet (choke) knob is returned to the original position before driving.



1. Starter knob

## Starting a warm engine

1. Turn the fuel petcock to "ON".
2. Turn the ignition key to the #1 position and engine stop switch to "RUN".
3. Slightly open the throttle grip.
4. Kick the kick crank with full strength or press the "START" switch to start the engine.

### NOTE:

Do not operate the starter jet (choke) knob when the engine is already warm.

### CAUTION:

See "Break-in Section" prior to operating engine for the first time.

### Warming up

To get maximum engine life, always "warm-up" the engine before starting off. Never accelerate hard with a cold engine! To see whether or not the engine is warm, see if it responds to throttle normally with the starter jet (choke) turned off.

## Shifting

A 5-speed transmission is employed. Low gear is at the bottom of the shift pattern; high gear at the top of the shift pattern; neutral is located half-way between first and second positions.

The shift mechanism is of the ratcheting type common to most motorcycles. Allow the lever to return to its "at rest" position prior to selecting another gear. Neutral is selected by pulling up or depressing the shift lever halfway between first and second gears.

With the engine running in the neutral position, disengage the clutch (pull in clutch lever), press down on the shift lever until low gear is engaged, remove foot from shift lever, increase engine speed slightly, slowly release clutch lever while advancing throttle.

Repeat procedure for remaining gears.

Except during competition, shift the transmission when engine speed is approximately 3,500 to 5,000 rpm. This can be interpreted as approximately one-half throttle. (See "Break-in").

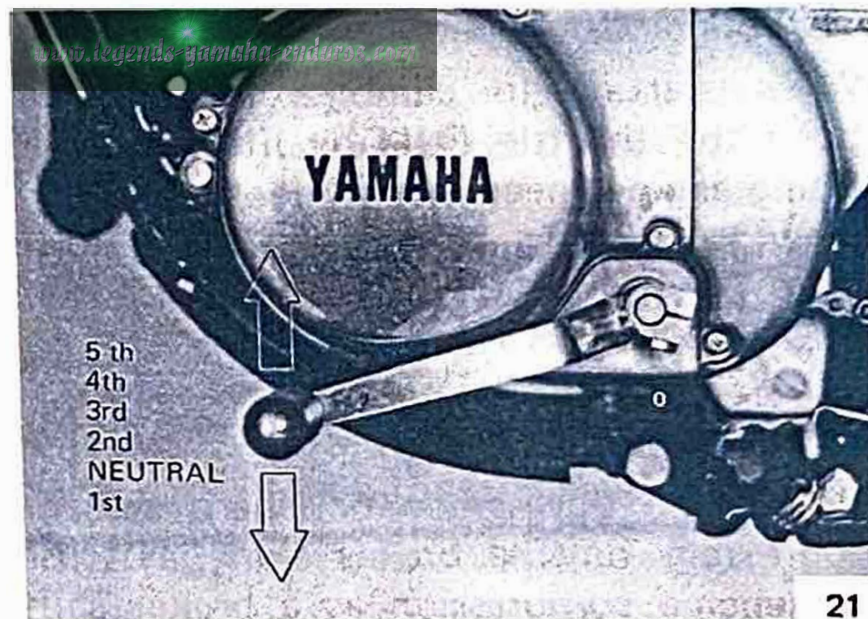

## Going Uphill

When starting to climb a gentle grade, open the throttle little by little to avoid losing engine speed and power.

When climbing a steep grade, shift down from THIRD to SECOND or from SECOND to FIRST as required.

## Going Downhill

On a long downgrade or sharp descent, don't rely on the brakes alone, but use the engine compression as a brake: shift into THIRD or SECOND as required by the grade and close the throttle.

## CAUTION: \_\_\_\_\_

Never turn off the ignition switch on a long hill.

This may cause the spark plug to foul, in addition to being unsafe.

---

## NOTE: \_\_\_\_\_

When using engine braking for long periods, it is very important not to exceed maximum recommended rpm (tachometer red zone). It is also necessary to open the throttle occasionally because the engine relies on the fuel for internal cooling.

---

## Off-road Riding

When you ride your motorcycle over rough land, safety parts may break or fall off due to shock from the ground or due to accidents such as falling, and breakage or loss of parts may result. It is advisable to remove all safety parts before you start riding.

Parts to be removed: Headlamp, taillamp, speedometer, tachometer.



### **Caution on Riding over Paved Roads at High Speeds:**

The DT125C is equipped with tires having a block pattern. As a result, the area where the tire contacts the ground is smaller compared with other types of tires. Therefore, take care to avoid slipping your motorcycle when you are cornering at high speeds and at sharp angles.

### **Stopping**

There are several ways to stop. Pulling in the clutch lever and twisting the throttle grip in the close direction will permit you to gradually glide to a stop. Downshifting through the gears, using the drag of the engine to slow down is another. However, the best method, and the one most universally used, is to use both engine compression (downshifting through the gears as the machine slows) and the front and rear brakes.

When stopping, gradually apply the rear brake while twisting the throttle grip in the closed direction. After the rear brake starts to take hold, gradually apply the front brake.

As the machine continues to slow, shift down through the gears using engine compression to aid the slowing effect. When shifting down, watch the tachometer to see that the engine does not over-rev.

### **NOTE:** \_\_\_\_\_

During periods of inclement weather such as snow, rain, sleet, or ice or on poor road surfaces where traction is minimal, or in a sharp corner, **IT IS NOT ADVISABLE TO FIRMLY APPLY THE FRONT BRAKE.** While it is true that the front brake supplies the greater portion of braking power, it is also true that stability can be upset very easily if it is used incautiously under the above conditions.

---

## Cruising

A frequently asked question is "What rpm should I cruise at?". The BREAK-IN section provides limitations when the motorcycle is new, but once the engine has been broken in, then we suggest that you follow these guide lines. For sustained load and throttle conditions, such as those encountered on open highways, cruise at 3/4 throttle or at 3/4 of the rpm "red line", whichever comes first. Always bear in mind, though, the maximum allowable speed limit for the area through which you are riding. This is a recommendation, not a "hard and fast" rule.

Any modification or personalization of the running gear could possibly change the operating range most comfortable and most efficient for the engine.

## Engine break-in

There is never a more important period, in the life of your motorcycle, than the period between zero and 500 mi. For this reason we ask that you carefully read the following material. Because the engine is brand new, you must not put an excessive load on it for the first several hours of running. During the first 500 mi the various parts in the engine wear and polish themselves to the correct operating clearances. During this period prolonged full throttle operation, or any condition which might result in excessive heat of cylinder, must be avoided. However, momentary full throttle operation, under load (2 – 3 seconds maximum), does not harm the engine.

Each full throttle acceleration sequence should be followed with a substantial rest period for the engine by cruising at lower rpm's so the engine can rid itself of the temporary build up of heat.

If any abnormality is noticed during this period, ask your Yamaha dealer to check.

**NOTE:** \_\_\_\_\_

Please read your Owner's Warranty Guide Book thoroughly. It explains your obligation during the break-in period.

---

1. 0 – 100 mi:

Avoid operation above 4,000 rpm. Allow a cooling off period of 5 to 10 minutes after every hour of operation. Vary the speed of the motorcycle from time to time. Do not operate it at one, set throttle position.

2. 100 – 250 mi:

Avoid prolonged operation above 5,000 rpm. Allow the motorcycle to rev freely through the gears but do not use full throttle at any time.

3. 250 – 500 mi:

Avoid prolonged full throttle operation. Avoid cruising speeds in excess of 6,000 rpm.

4. 500 mi and beyond:

Avoid prolonged full throttle operation. Avoid engine speeds in excess of 7,000 rpm. Vary speeds occasionally.

**NOTE:** \_\_\_\_\_

Please refer to your Owner's Warranty Guide book and the Maintenance and Lubrication charts for information regarding Initial Service Checks.

---

### Parking

When parking, stop the engine and remove the ignition key. Make it a habit to turn the fuel petcock to "OFF" whenever stopping the engine.

**NOTE:** \_\_\_\_\_

Select a parking place where the motorcycle is not apt to fall.

---

## PERIODIC MAINTENANCE AND MINOR REPAIR

### Tool kit

The tools provided in the owner's tool kit are sufficient for periodic maintenance and minor repair purpose, except that a torque wrench is also necessary to properly tighten nuts and bolts.

Should you desire additional service information on this model a copy of Service Manual can be purchased from any Authorized Yamaha Dealer.

### CAUTION: \_\_\_\_\_

The following sections provide information for the disassembly, troubleshooting and maintenance of various components of the motorcycle. If you do not have the necessary tools and an understanding of the mechanical principles involved, please refrain from attempting repairs. The use of improper tools and/or procedures can cause major damage to the unit with resultant additional repair costs.

---

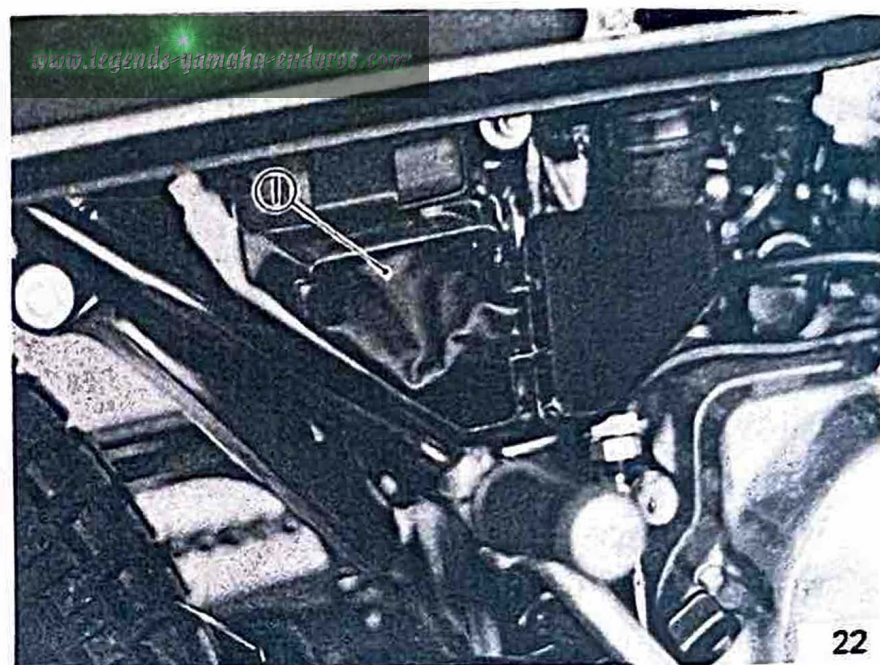

22

1. Tool kit

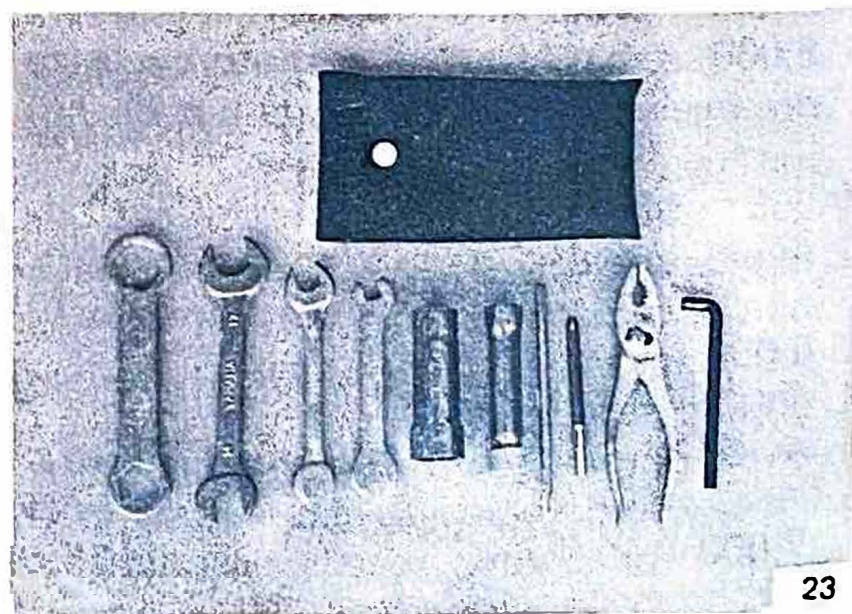

23

## PERIODIC MAINTENANCE

Periodic inspection, adjustment and lubrication will keep your motorcycle in the safest and most efficient condition. Safety is an obligation of the motorcycle owner.

The most important points of motorcycle inspection, adjustment and lubrication are explained below; if the owner is not familiar with motorcycle service, this work should be done by a Yamaha dealer.

### Lubrication Intervals

Page	Item	Remarks	Type	Initial (mile)				Thereafter Every (mile)		
				250	500	1,000	2,000	1,000	2,000	4,000
31,32	Transmission Oil Change	Warm engine before draining	No.1	CHK	○	○		CHK	○	
48~50	Drive Chain	Lube/Adjust as req'd	No.2	See Notes						
48~50	Drive Chain	Remove/clean/lube/adjust	No.2			○		○		
50	Control & Meter Cables	All-apply thoroughly	No.3			○	○		○	
51	Throttle Grip & Housing	Light Application	No.4				○		○	
Dealer	Tach & Speedo Gear Hsgs.	Light Application	No.4				○			○
—	Rear Arm Pivot Shaft	Zerk-Apply until shows	No.5			○		○		
—	Brake Pedal Shaft	Light Application	No.4			○			○	
—	Change Pedal Shaft	Light Application	No.4			○			○	
—	Stand Shaft Pivot(s)	Light Application	No.4			○			○	
Dealer	Front Forks	Drain completely	No.8		CHK		○	CHK	○	
Dealer	Steering Ball Races	Inspect thoroughly	No.6				○		CHK	○
Dealer	Point Cam Lubr. Wick	Very light application	No.7			○				○
Dealer	Wheel Bearings	Do not over-pack	No.6				○	CHK	○	

See Service Notes on following page.

Be sure to check the above points before long-distance touring.

## Recommended lubricant type

- No.1. Use Yamalube 4-cycle oil, or SAE 20W/40 type "SE" motor oil.
- No.2. Use SAE 10W/30 type "SE" motor oil.  
(If desired, specialty type lubricants of quality manufacture may be used.)
- No.3. Use SAE 20W/40 type "SE" motor oil.  
(If desired, or at ambient temperature below 30°F, a graphite base "dry" lubricant of quality manufacture may be used.)
- No.4. Light duty: Lithium soap base grease.  
Heavy duty: Standard chassis lube grease. (Do not use chassis lube grease on throttle/throttle housing.)

- No.5. Use a soft chassis lube grease (short fiber)
- No.6. Medium-weight wheel bearing grease of quality manufacture—preferably waterproof.
- No.7. Light-weight machine oil.
- No.8. Use Yamaha fork oil.

### NOTE: \_\_\_\_\_

Drive chain must be lubricated every 200 – 250 miles. If unit is subjected to extremely hard use, chain must be inspected frequently and serviced as required.

---

## PERIODIC MAINTENANCE CHART

Page	Item	Remarks	Initial (mile)				Thereafter Every (mile)	
			250	500	1,000	2,000	1,000	2,000
45,46	Brake System (complete)	Check/Adj. as req'd repair as req'd		○	○		○	
42,43	Clutch	Check/Adjust as required		○	○		○	
43,44	Battery	Top-off/Chk. spec. gravity monthly, or	○		○		○	
33,34	Spark Plug(s)	Inspect/Clean or replace as req'd	○	○	○		○	
54~61	Wheels & Tires	Pressure/Spoke—Tension/runout	○	○	○		○	
—	Fittings & Fasteners	Tighten before each trip and/or	○	○	○		○	
48~50	Drive Chain	Tension/Alignment No.1	○	○	○		○	
31,32	Transmission Oil Level Check	Unit level/Engine warm	○	○	○		○	
35,36	Air Filter	Wet type—Clean/replace as re'd No.2			○	○		○
41	Fuel Petcock(s)	Clean/flush tank as req'd	○		○		○	
Dealer	Ignition Timing	Adjust/clean or replace pts. as req'd		○	○	○		○
36~39	Carburetor Adjustment	Check operation/fittings		○	○	○		○
Dealer	Carburetor Overhaul	Clean/repair as req'd./refit/adjust						4,000
Dealer	Cylinder Compression	Preventive Maintenance Check		○	○	○		○
Dealer	Decarbonize Engine	Includes Exhaust System			○			○

### SERVICE NOTES:

No. 1. DRIVE CHAIN: In addition to tension and alignment, chain must be lubricated every 200 – 250 mi (300 – 400 km). If unit is subjected to extremely hard usage and wet weather riding, chain must be checked constantly. See "Lubrication Intervals" for additional details.

No. 2. AIR FILTER: Remove and clean filter at least once per month or every 1,000 mi (1,600 km).

## Torque specifications

The list below covers those stud bolt sizes with standard I.S.O. pitch threads. Torque specifications for components with thread pitches other than standard are given within the applicable chapter.

Torque specifications call for dry, clean threads. Components such as the cylinder or cylinder head should be at room

temperature prior to torquing. A cylinder head or any other item with several fasteners should be torqued down in a crisscross pattern in successive stages until torque specification is reached. The method is similar to installing an automobile wheel and will avoid warping the component.

A (mm) (nut)	B (mm) (bolt)	Torque specification		
		m-kg.	ft-lb.	in-lb.
10	6	1.0	7	85
12	8	2.0	15	175
14	10	3.5 ~ 4.0	25 ~ 30	300 ~ 350
17	12	4.0 ~ 4.5	30 ~ 35	350 ~ 400
19	14	4.5 ~ 5.0	30 ~ 35	400 ~ 400
22	16	5.5 ~ 6.5	41 ~ 49	480 ~ 570
24	18	6.0 ~ 7.0	40 ~ 50	500 ~ 600
27	20	7.0 ~ 8.0	50 ~ 60	600 ~ 700
Spark plug		2.5 ~ 3.0	20 ~ 22	230 ~ 250

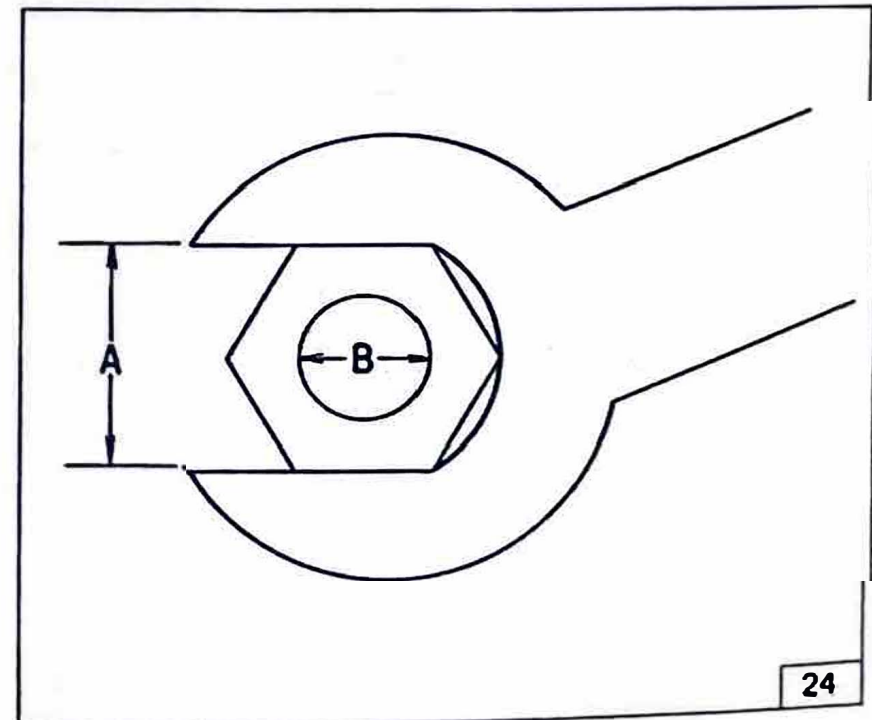



## Engine oil

Use the engine oils in the following list. We recommend Yamalube 2-cycle (available at most Yamaha dealers) but, if other oils are used, select from the following list which is given in order of preference.

1. 2-stroke engine oil labelled "BIA certified for service TC-W".
2. SAE 30 weight, detergent type automobile engine oil with an "SE" rating. This last oil should be used only as an emergency measure when 2-stroke oils are not available.

### NOTE:

Oil viscosity increases in very cold weather (where the normal temperature is below 0°C, 32°F) and oil does not circulate as well. In such areas, consult your Yamaha dealer.

Oil tank capacity: 1.3 U.S. qt (1.2 lit)
---------------------------------------------

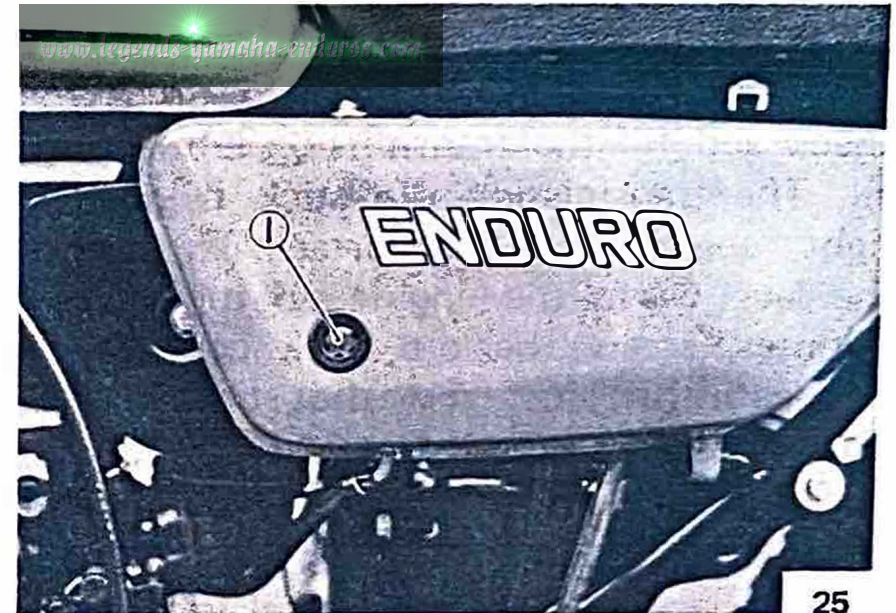

1. Refill if level shows.

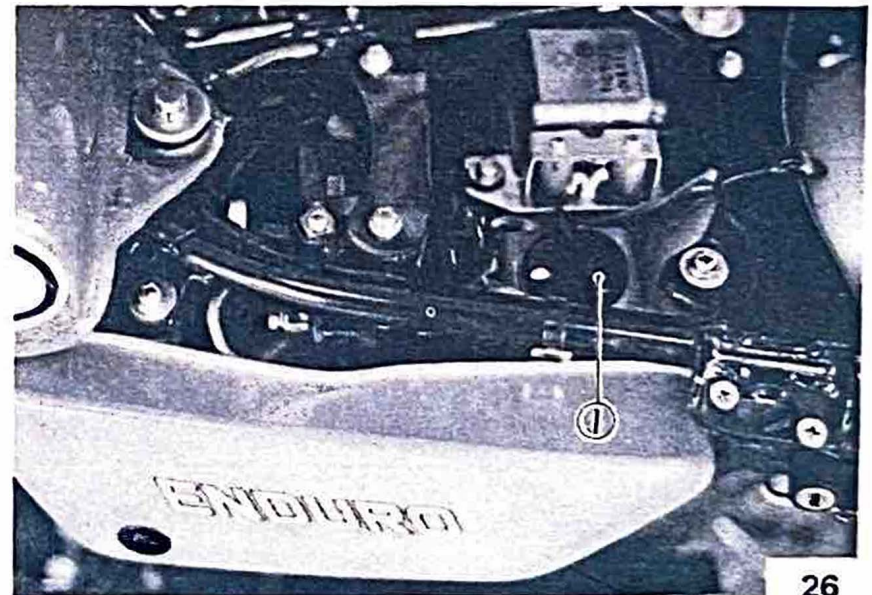

1. Oil tank filler cap

## Transmission oil

The only servicing for you to do is to check and fill the transmission lubricating oil. The transmission dip stick is located right above the kickstarter. To check the level, warm the engine up for several minutes, screw the dip stick completely out and then just rest the stick in the hole.

### NOTE:

When checking transmission oil level with the dip stick, let the unscrewed dip stick just rest on the case threads. Also, be sure the machine is positioned straight up and on both wheels.

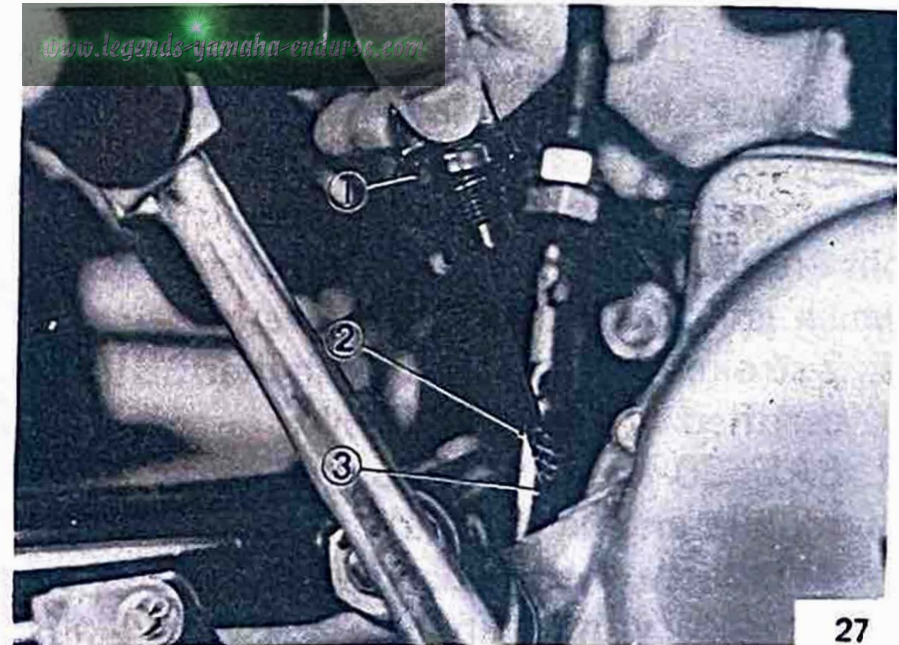

1. Dip stick
2. Maximum level
3. Minimum level

**Recommended oil:**

Yamalube 4-cycle or SAE 20W/40 motor oil, type "SE" 0.8 qt (750 cc)

The dip stick has a Minimum and a Maximum mark, and the oil level should be between the two. If the level is lower, then add sufficient oil to raise it to the proper level.

During the break-in period, you should replace the gear oil 30 days after the date of purchase or thereafter 2,000 mi (3,200 km). The transmission should be drained and refilled approximately every 2,000 mi (3,200 km). On the bottom of the engine there is a drain plug. Remove it and drain all the transmission oil out.

Reinstall the drain plug (make sure it is tight). Add oil through the dip stick hole.

**NOTE:**\_\_\_\_\_

Do not add any chemical additives. Transmission oil also lubricates the clutch and additives could cause the clutch to slip.

---

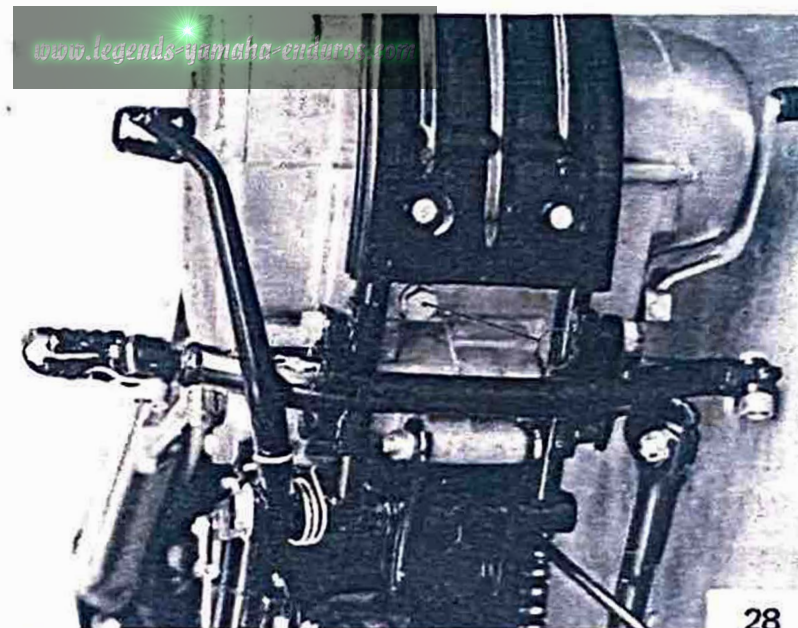

1. Drain plug

## Spark plug inspection

The spark plug is one of the most important of the engine components and is the easiest to inspect. By examining the condition of the spark plug we can, to some extent, determine the condition of the engine.

If the engine is operating correctly, and the machine is being ridden correctly, the white porcelain insulator around the center electrode will be a medium to light tan color.

If the porcelain is very dark brown or black color and the firing end is wet with oil or sooty, the spark plug may be too "cold". A "hotter" spark plug may be required. This situation is common during engine break-in.

If the insulator is glazed and very light or white in color, or if the electrodes show signs of melting, a "colder" spark plug may be required.

If spark plug appearance indicates a performance problem, ask a Yamaha dealer to investigate the situation. Do not

change the spark plug type without consulting with your dealer. You should, however, periodically remove and inspect the spark plug because heat and deposits will cause any spark plug to slowly breakdown and erode. If electrode erosion becomes excessive, or if carbon and other deposits are excessive, you should replace the spark plug with one of the proper type.

Standard spark plug: NGK B-8ES



29

Spark plugs are produced in several different thread lengths. The thread length (reach) is the distance from the spark plug gasket seat to the end of the threaded portion. If the reach is too long, overheating and engine damage may result. If the reach is too short, spark plug fouling and poor performance may result; also, carbon will form on the exposed threads resulting in combustion chamber hot spots and thread damage. Always use a spark plug with the proper reach.

**Spark plug reach : 3/4 in (19 mm)**

Before installing any spark plug, measure the electrode gap with a wire thickness gauge and adjust to specifications.

**Spark plug gap:  
0.020 – 0.024 in (0.5 – 0.6 mm)**

When installing the plug, always clean the gasket surface and use a new gasket. Wipe off any grime from the threads and torque the spark plug properly.

**Spark plug torque:  
20 – 22 ft-lb (2.5 – 3.0 m-kp)**

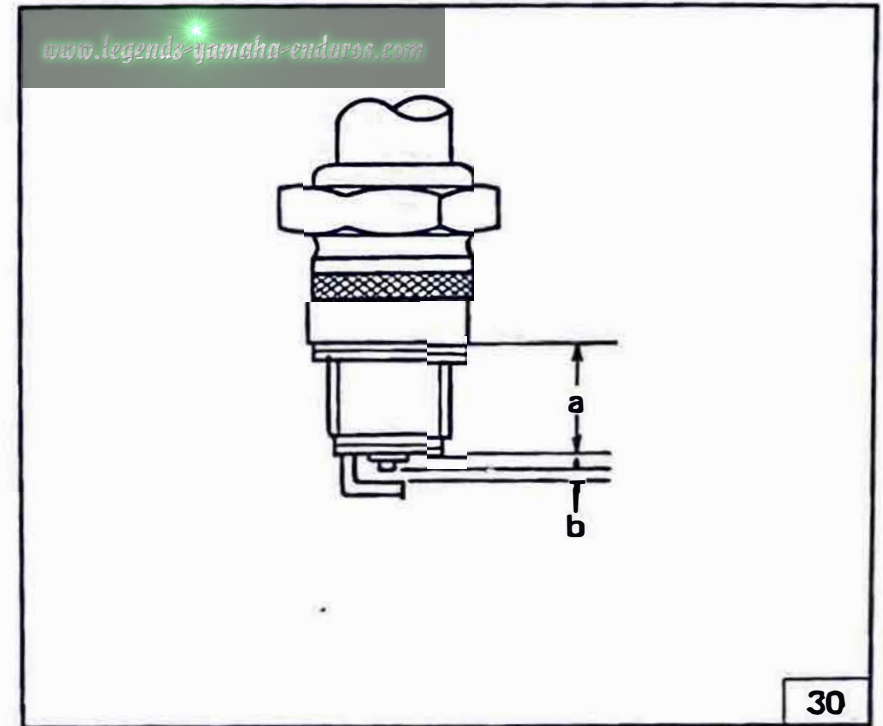

- a: Reach 3/4 in (19 mm)
- b: Gap 0.020 – 0.024 in  
(0.5 – 0.6 mm)

## Cleaning the air filter element

The air filter protects the engine from dirt which can enter with the intake air and cause rapid engine wear. This dirt is filtered from the air by the air filter element. This model uses a cartridge type air filter element which consists of foam rubber moistened with oil. When this filter element becomes dirty it should be cleaned with solvent and reoiled.

### Cleaning method

1. Remove the oil tank holding screws, and remove the oil tank.
2. Remove the air filter element from its case, remove element from core and clean with solvent. After cleaning, remove the remaining solvent by squeezing the foam rubber.
3. Then apply 30 wt motor oil to the entire surface and squeeze out the excess oil. Foam should be wet but not dripping.
4. When installing the air filter element in its case, be sure its sealing surface matches perfectly the sealing surface of the case so there is not air leakage.

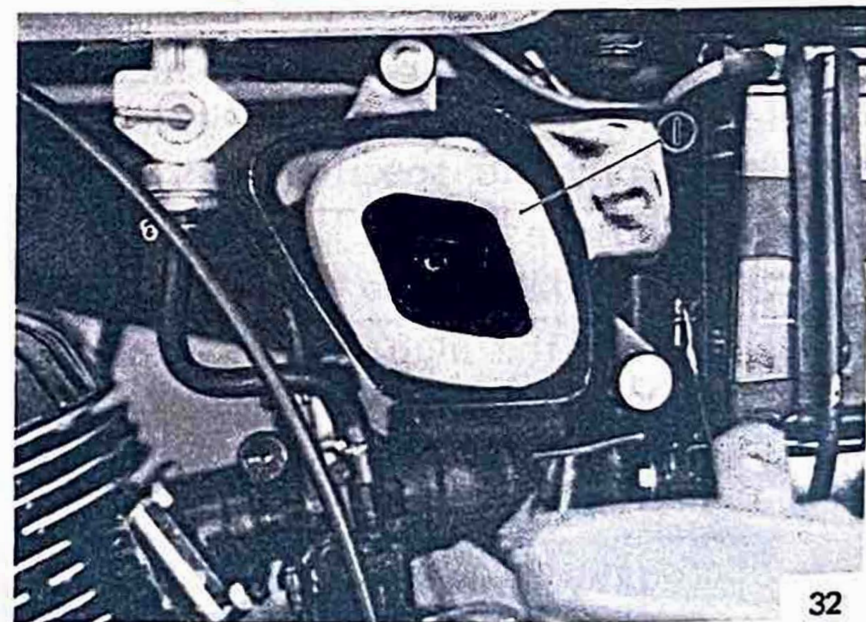
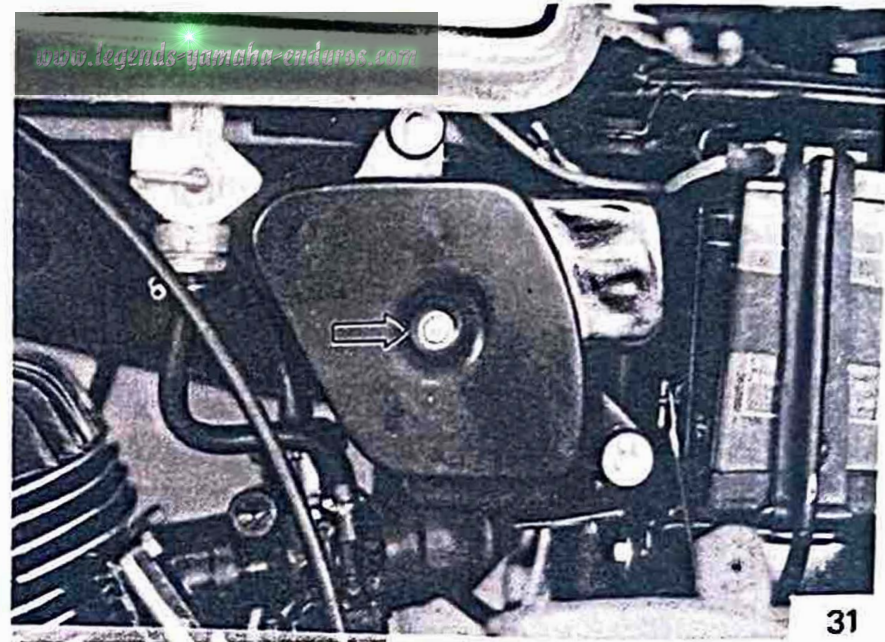

1. Air filter element

5. The air filter element should be cleaned once a month or every 1,000 miles. It should be cleaned every ten hour or more often if the machine is operated in extremely dusty areas.

**NOTE:** \_\_\_\_\_

The engine should never be run without the air cleaner element installed; overheating and piston damage may result.

---

### **Carburetor adjustment**

The carburetor is a vital part of the engine and requires very sophisticated adjustment. Most adjusting should be left to a Yamaha dealer who has the professional knowledge and experience to do so. However, the following three points may be serviced by the owner as part of his usual maintenance routine.

1. Idle mixture adjustment
2. Idling speed adjustment
3. Throttle cable play adjustment

**NOTE:** \_\_\_\_\_

The carburetor was set at the Yamaha factory after many tests. If the settings are disturbed without having technical knowledge, poor engine performance and damage may result.

---

## Idle mixture adjustment

The idle mixture adjustment controls the amount of mixture to the engine at low rpms. The idle mixture also insures smooth transition to the main circuit with no power loss or misfire; so it does affect midrange performance.

Make this adjustment as described below: Tighten the pilot air screw until it lightly touches the seat; then back the screw out the specified number of turns. This should be done with the engine stopped.

Standard pilot air screw setting (number of turns out): 1-3/4.

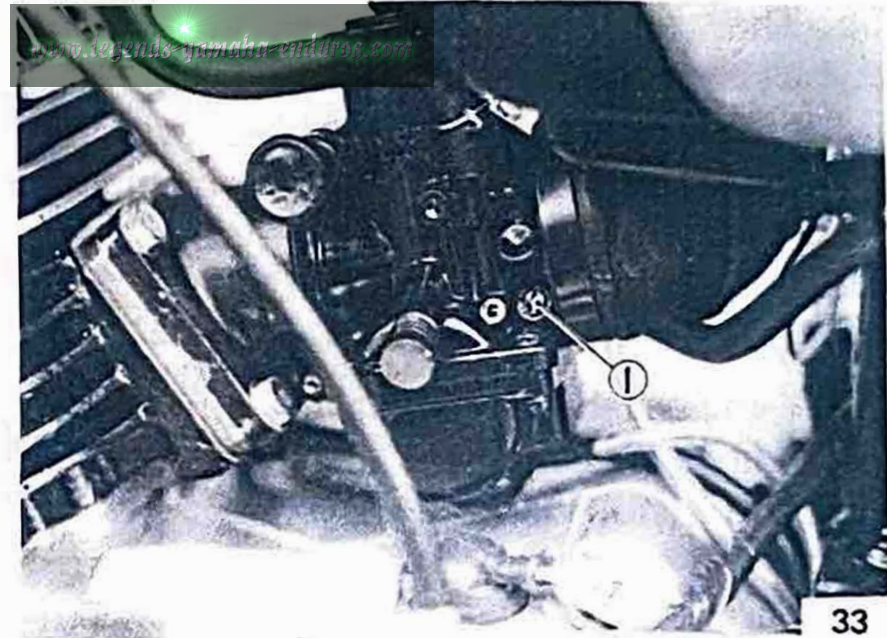

1. Pilot air screw



## Idling rpm adjustment

Start the engine and warm it up for a few minutes (normally, 1 or 2 minutes) at approximately 1,000 to 2,000 rpm, occasionally raising to 5,000 to 7,000 rpm for a few seconds. When the engine responds quickly, the warm up as complete. Tighten or loosen the throttle stop screw as required to obtain the specified engine rpm while watching the tachometer.

<p>Standard idling rpm: 1,300 – 1,400 rpm</p>
---------------------------------------------------

## Carburetor inspection

In addition to the above adjustment, check the following periodically.

1. Are the carburetor hose clamps loose?
2. Is the cleaner joint secure?
3. Is the overflow pipe or air vent pipe out of place?
4. Is the mixing chamber top on tight?

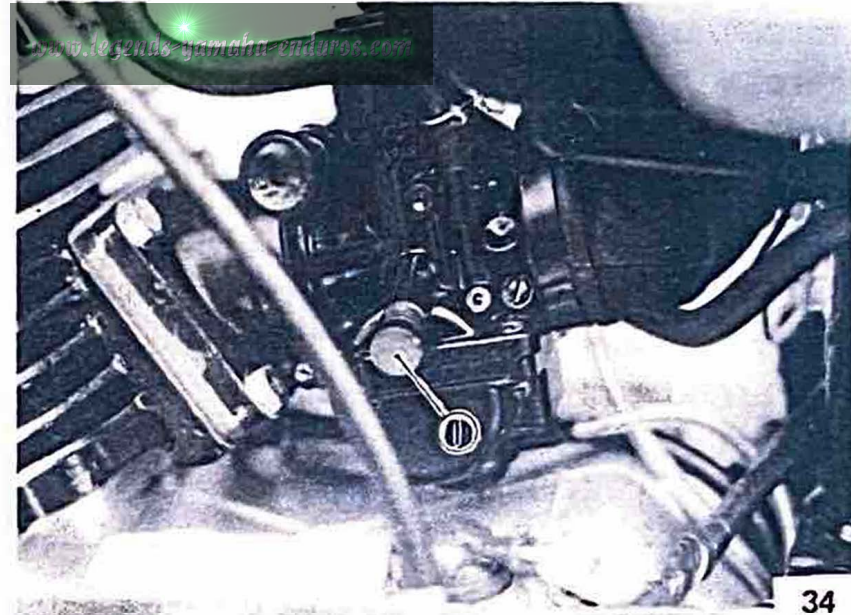

1. Throttle stop screw

## Inspection and adjustment of play in throttle cable 2

A throttle cable should always have a little play in it. If too tight, a sharp turn may cause the engine speed to increase. On the other hand, if the throttle valve does not open fully when the throttle grip is turned fully, full speed is not possible. Adjust as described below.

### NOTE:

Before adjusting the play in throttle cable 2, adjust the engine idling speed and make sure the mixing chamber top is tight.

1. Move the rubber cover of the mixing chamber top to expose the wire adjuster.
2. Hold the outer cable near top of carburetor and down to check the play.
3. Loosen locknut and turn the wire adjuster in or out to achieve 0.04 in (1 mm) of play. Be sure to tighten the locknut.

## Inspection and adjustment of play in throttle cable 1

The following explains the adjustment of throttle cable 1 (see illustration).

### NOTE:

Adjust the play in both throttle cables; if only one is adjusted, trouble may occur.

Check play in turning direction of throttle grip. The play should be 0.12–0.24 in (3–6 mm) at grip flange, loosen the locknut and turn the wire adjuster to make the necessary adjustment. After adjusting, be sure to tighten the locknut properly.

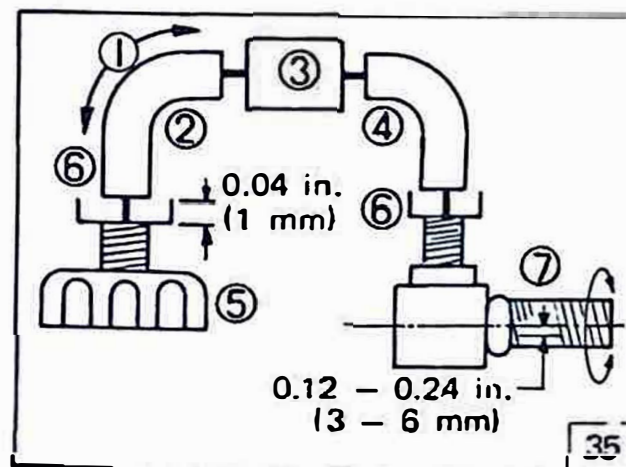

1. Slide
2. Cable 2
3. Junction block
4. Cable 1
5. Carburetor cap
6. Cable adjuster
7. Throttle grip

## Autolube pump cable adjustment

Close the throttle grip completely, then twist it open until all cable slack is removed, but stop before the slides start to lift.

Adjust the pump cable so the mark on the pump pulley lines up with the "adjust pulley guide pin". The Autolube cable adjuster is located at the bottom end of the cable, screwed into the top of the right case cover.

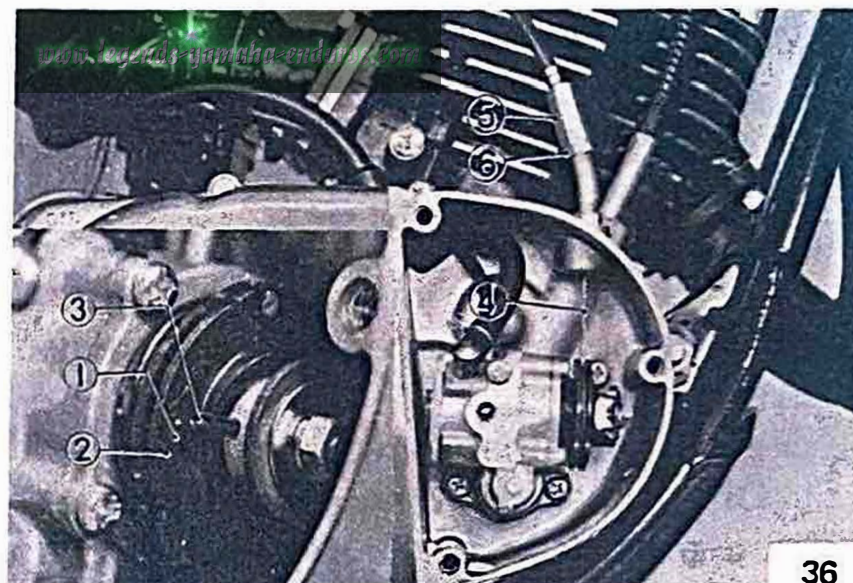

36

- |                  |                      |
|------------------|----------------------|
| 1. Mark (□)      | 4. Pump cable        |
| 2. Adjust pulley | 5. Adjuster          |
| 3. Pin           | 6. Adjuster lock nut |

## Bleeding the Autolube pump

If the pump runs out of oil, the pump must be bled to release air trapped in the pump. Remove the phillips head bleed screw, twist the throttle to full open position (turns the Autolube pump to maximum stroke), and rotate the plastic manual starter pump plate until only oil comes out the bleed hole (air stops coming out with the oil). Reinstall and tighten the bleed screw.

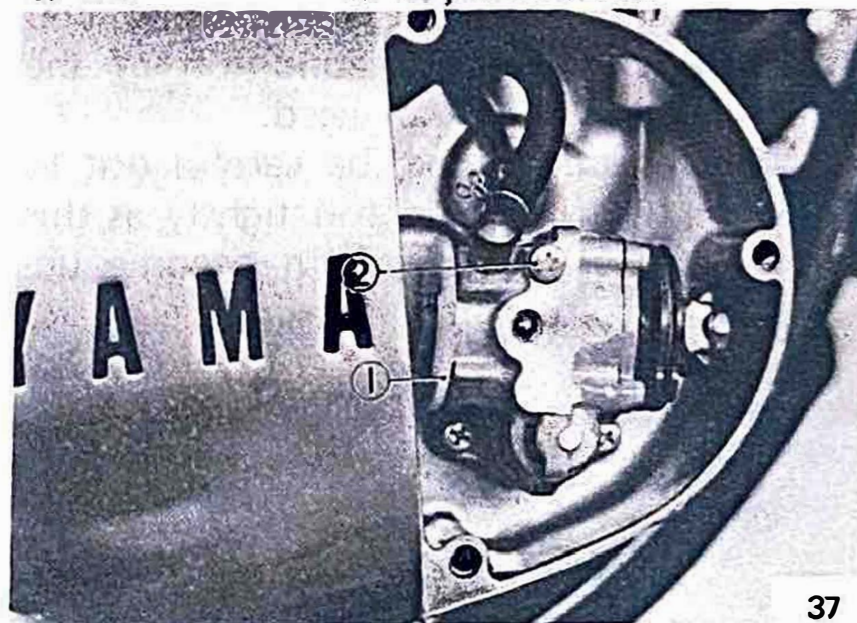

37

- |                  |                |
|------------------|----------------|
| 1. Starter plate | 2. Bleed screw |
|------------------|----------------|

## Fuel petcock inspection and cleaning

The fuel petcock has a built-in filter to remove any particles before they reach the carburetor. If the filter becomes blocked, the fuel cannot enter the carburetor. To prevent this, inspection and cleaning should be done at recommended intervals.

1. First, turn the petcock lever to the "OFF" position; then remove the filter cup and clean the bottom of the cup with solvent.
2. After removing the filter cup, clean the filter screen. At the same time, you should examine the condition of the O-ring. Replace if damaged.
3. When reassembling, be careful not to clamp the filter cup too tightly as this may cause the O-ring to become unseated resulting in fuel leakage.

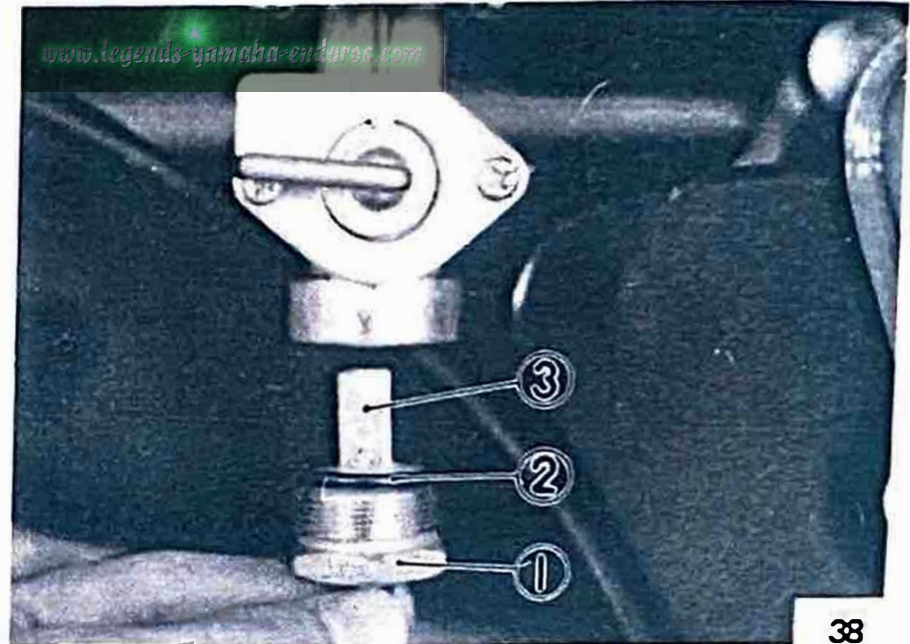

1. Filter cup
2. O-ring
3. Filter screen

38

## Clutch adjustment

This model has two clutch cable length adjusters and a clutch mechanism adjuster. Cable length adjusters are used to take up slack from cable stretch and to provide sufficient free play for proper clutch operation under various operating conditions. The clutch mechanism adjuster is used to provide the correct amount of clutch "throw" for proper disengagement. Normally, once the mechanism is properly adjusted, the only adjustment required is maintenance of free play at the clutch handle lever.

### 1. Freeplay adjustment

Loosen the handle lever adjuster locknut. Next, turn the length adjuster in or out until proper lever free play is achieved.

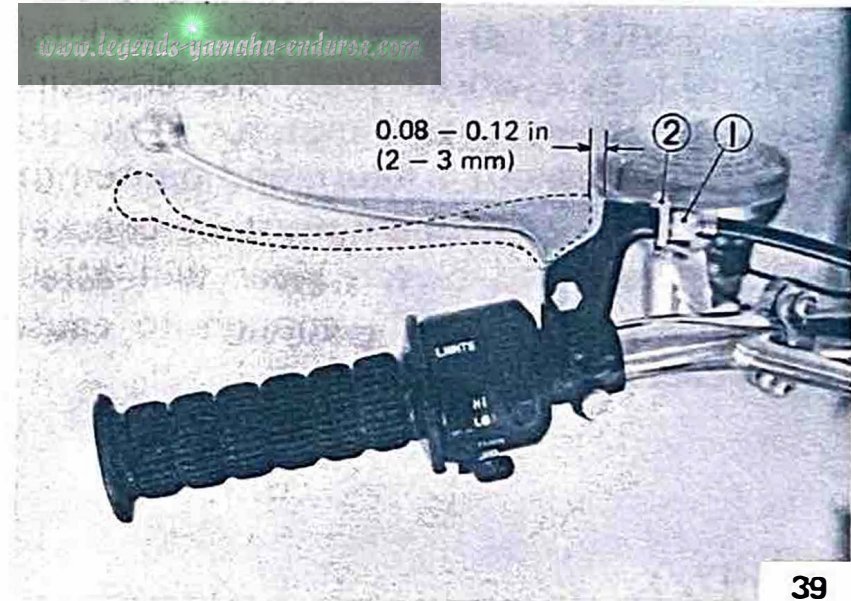

1. Adjuster
2. Adjuster lock nut

## 2. Mechanism adjustment

Remove generator cover. Loosen the adjusting screw lock nut and rotate the adjusting screw in until it lightly seats against a clutch push rod that works with the adjusting screw to operate the clutch. Back the adjusting screw out 1/4 turn and tighten the locknut. This adjustment must be checked because heat and clutch wear will affect this free play, possibly enough to cause incomplete clutch operation.

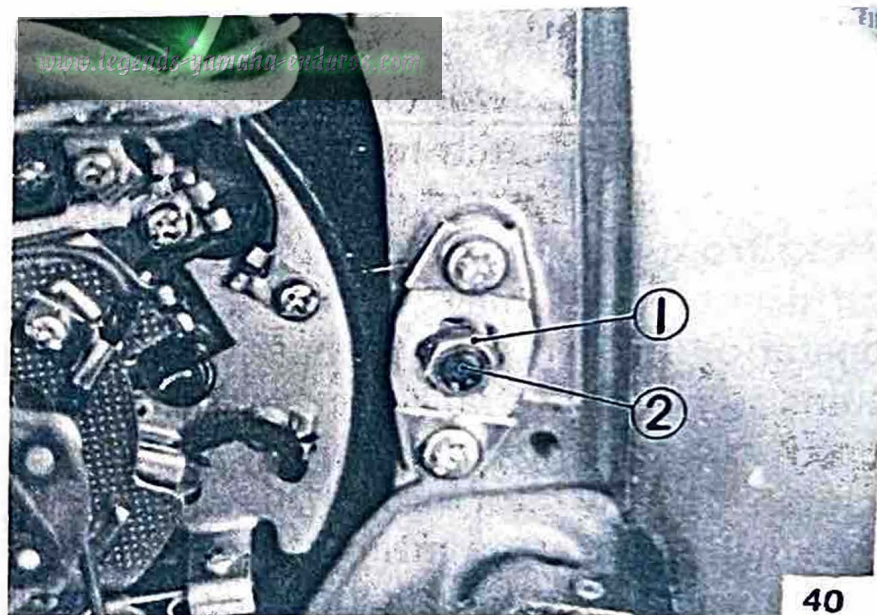

1. Adjusting screw lock nut 2. Adjusting screw

## Battery

Remove the oil tank. (Refer to page 35)  
Check the level of the battery fluid. Add distilled water if the fluid level is low.

### Replenishing the battery fluid

A poorly maintained battery will deteriorate quickly. The battery fluid should be checked at least once a month.

1. The level should be between the upper and lower level marks. Use only distilled water if refilling is necessary.

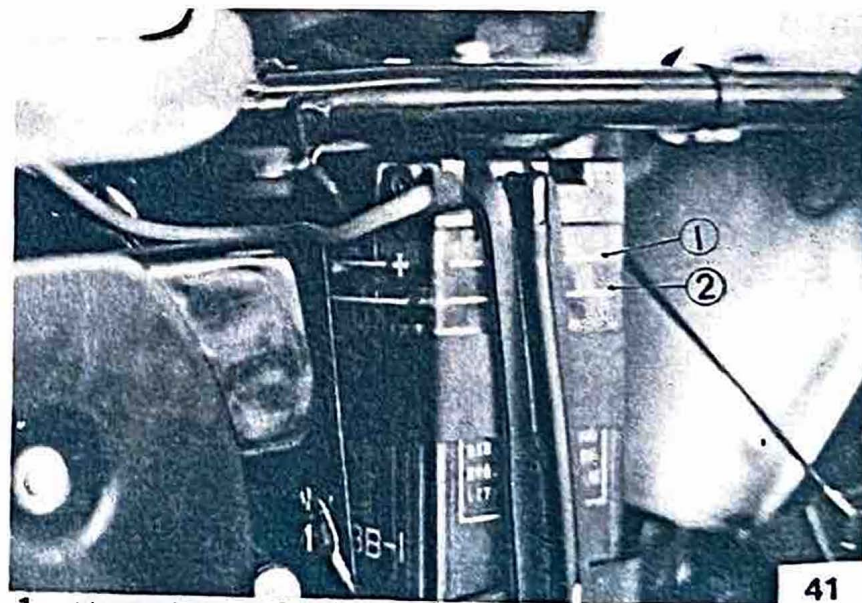

1. Upper level 2. Lower level

**NOTE:** \_\_\_\_\_

Normal tap water contains minerals which are harmful to a battery; therefore, refill only with distilled water.

---

2. When the motorcycle is not to be used for a month or longer, remove the battery and store it in a cool, dark place. Completely recharge the battery before reusing.
3. If the battery is to be stored for a longer period than the above, check the specific gravity of the fluid at least once a month and recharge the battery when it is too low.

4. Always make sure the connections are correct when putting the battery back in the motorcycle. The red lead is for the + terminal and the black lead is for the - terminal. Make sure the breather pipe is properly connected and is not damaged or obstructed.

## Front brake adjustment

The front brake can be adjusted in two ways; (1) using the adjuster at the front brake lever or (2) at the front brake shoe plate. Adjustment at the front brake lever is normally recommended. Loosen the locknut and turn the adjuster to adjust the brake lever. As shown in the illustration, the clearance between the brake lever and the brake lever holder should be 0.2 – 0.3 in (5 – 8 mm).

After adjusting, be sure the locknut is tightened firmly. When it is impossible to make an adjustment at the brake lever ask a Yamaha dealer for adjustment at the brake shoe plate.

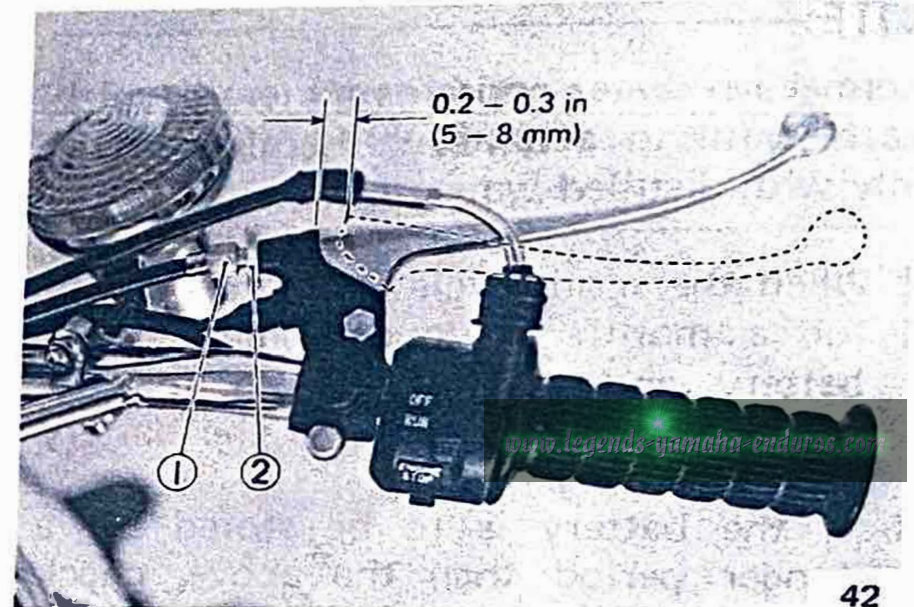

1. Adjuster
2. Adjuster lock nut

42



## Rear brake adjustment

The rear brake should be adjusted so the end of the brake pedal moves 0.8 – 1.1 in (20 – 30 mm). To adjust, turn the adjusting nut on the brake rod clockwise to reduce play: turn the nut counterclockwise to increase play. Check whether or not the stop light operates correctly after adjusting.

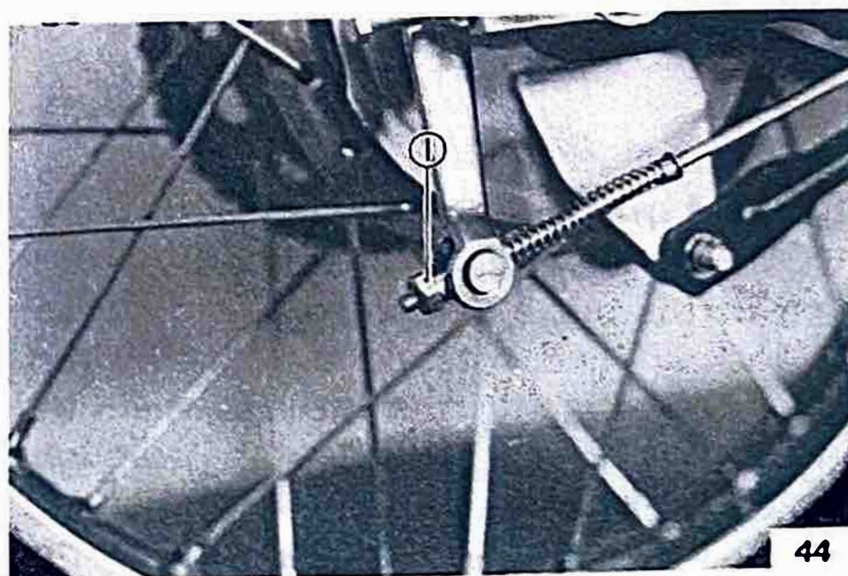
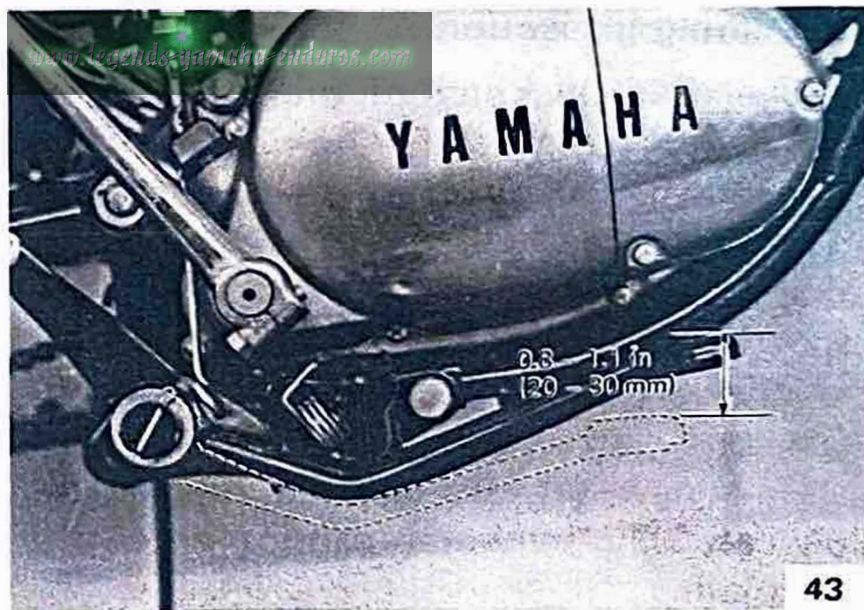

1. Adjusting nut

## Brake lining inspection

The specified thickness of the brake lining is 0.16 in (4 mm). The lining should be replaced when it wears to less than 0.079 in (2 mm).

To inspect, remove the plug from the inspection hole on the brake shoe plate and check the thickness of the lining. If worn out, ask your Yamaha dealer to install a new set. Be sure to replace the plug carefully so water cannot enter the shoe plate.

## Stoplight switch adjustment

The stoplight switch is operated by movement of the brake pedal. To adjust, loosen the locknut and rotate the adjusting nut. Proper adjustment is achieved when the brake starts to take effect and the stoplight illuminates simultaneously. After adjusting, tighten the locknut.

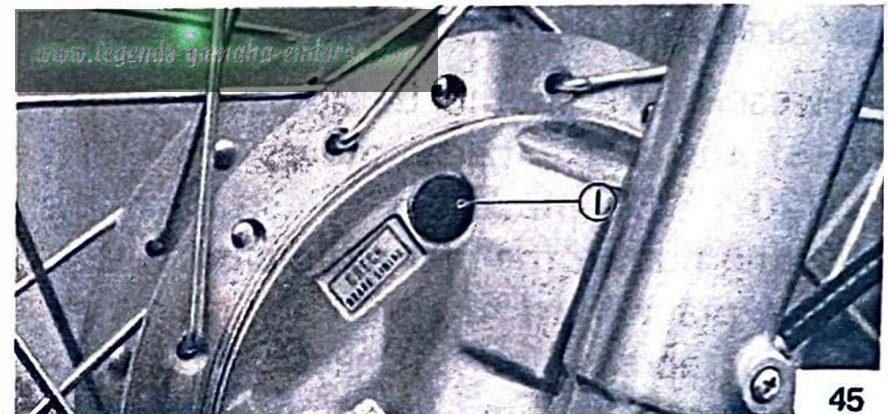

1. Inspection hole (Front brake)

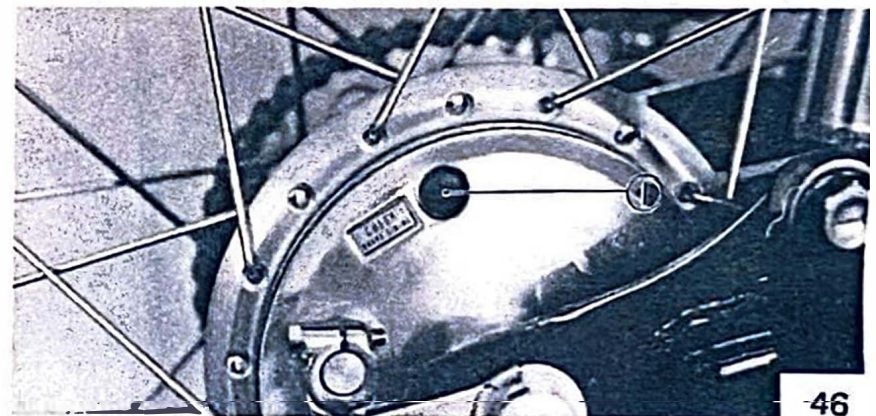

1. Inspection hole (Rear brake)

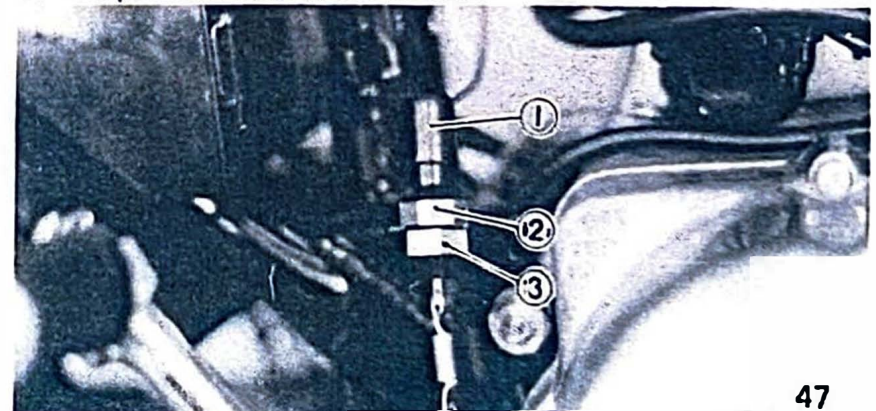

1. Stoplight switch 2. Adjusting nut 3. Locknut

### Drive chain tension check

Inspect the drive chain with both tires touching the ground. Check the tension at the position shown in the illustration. The normal vertical deflection is approximately 3/4 in (20 mm). If the deflection exceeds 3/4 in (20 mm) adjust the chain tension.

### Drive chain tension adjustment

1. Loosen the rear brake adjusting nut.
2. Remove the cotter pin of the rear wheel axle nut with pullers.
3. Loosen the rear wheel axle nut.
4. Loosen the adjusting bolt locknuts on each side. To tighten chain turn chain puller adjusting bolts clockwise. To loosen chain turn adjusting bolts counterclockwise and push wheel forward. Turn each bolt exactly the same amount to maintain correct axle alignment (There are marks on each side of rear arm and on each chain puller; use them to check for proper alignment).

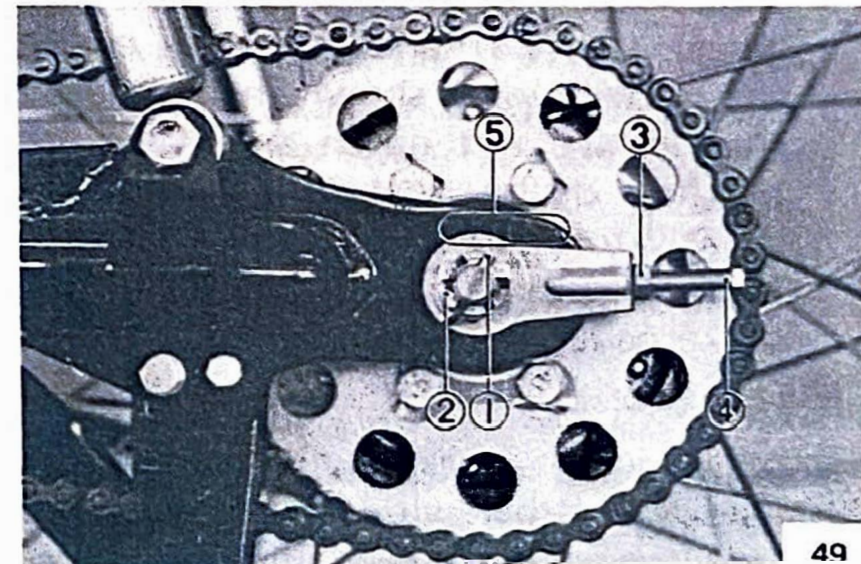
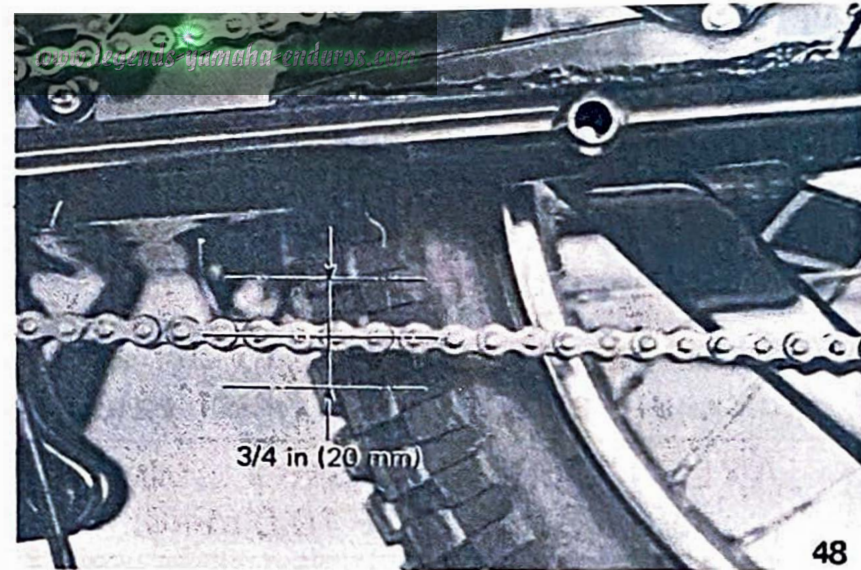

1. Cotter pin
2. Axle nut
3. Lock nut
4. Adjusting bolt
5. Marks for alignment

**NOTE:** \_\_\_\_\_

Before adjusting, rotate rear wheel through several revolutions and check tension several times to find the tightest point. Adjust chain tension with rear wheel in this "tight chain" position.

5. After adjusting, be sure to tighten the locknuts and the rear wheel axle nut.

**AXLE NUT TORQUE**

50–72 ft-lb (7.0–10.0 m-kg)

6. Insert the cotter pin into the rear wheel axle nut and bend the end of the cotter pin as shown in the illustration (if the nut notch and the cotter pin hole do not match, loosen the nut slightly to match).
7. In the final step, adjust the play in the brake pedal.

**NOTE:** \_\_\_\_\_

Excessive chain tension will overload the engine and other vital parts; keep the tension within the specified limits. Also, replace the rear axle cotter pin with a new one.

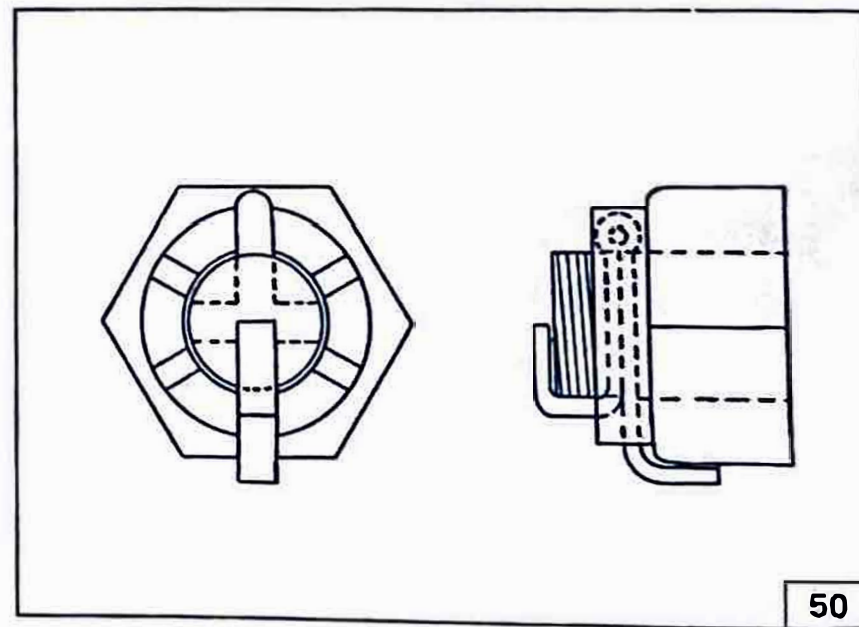

## Drive chain lubrication

The chain consists of many parts which work against each other. If the chain is not maintained properly, it will wear out rapidly. Without lubrication the chain could wear out within 100 miles, therefore, form the habit of periodically servicing the chain. This service is especially necessary when driving in dusty conditions.

1. Use any of the many brands of spray type chain lubricant. First, remove dirt and mud from the chain with a brush or cloth and then spray the lubricant between both rows of side plates and on all center rollers. This should be performed every 200 miles.
2. To clean the entire chain, first remove the chain from the motorcycle, dip it in solvent and clean out as much dirt as possible. Then take the chain out of the solvent and dry it. After drying, lubricant the chain to prevent the formation of rust.

## Cable inspection and lubrication

1. Damage to the outer housing of the various cables, may cause corrosion and often free movement will be obstructed. An unsafe condition may result so replace as soon as possible.
2. If the inner cables do not operate smoothly, lubricate or ask your Yamaha dealer to replace them.

Recommended lubricant:

SAE 10W/30 Type "SE" motor oil

## Throttle cable and grip lubrication

The throttle twist grip assembly should be greased at the time that the cable is lubricated, since the grip must be removed to get at the end of the throttle cable. Two screws clamp the throttle housing to the handlebar. Once these two are removed, the end of the cable can be held high to pour in several drops of lubricant. With the throttle grip disassembled coat the metal surfaces of the grip assembly with a suitable all-purpose grease to cut down friction. (See lubrication chart)

## Lubrication of Levers, pedals, etc.

1. Lubricate the pivoting parts of the brake and clutch levers with motor oil (10W/30).
2. Lubricate the shaft of the brake pedal with lithium soap grease.

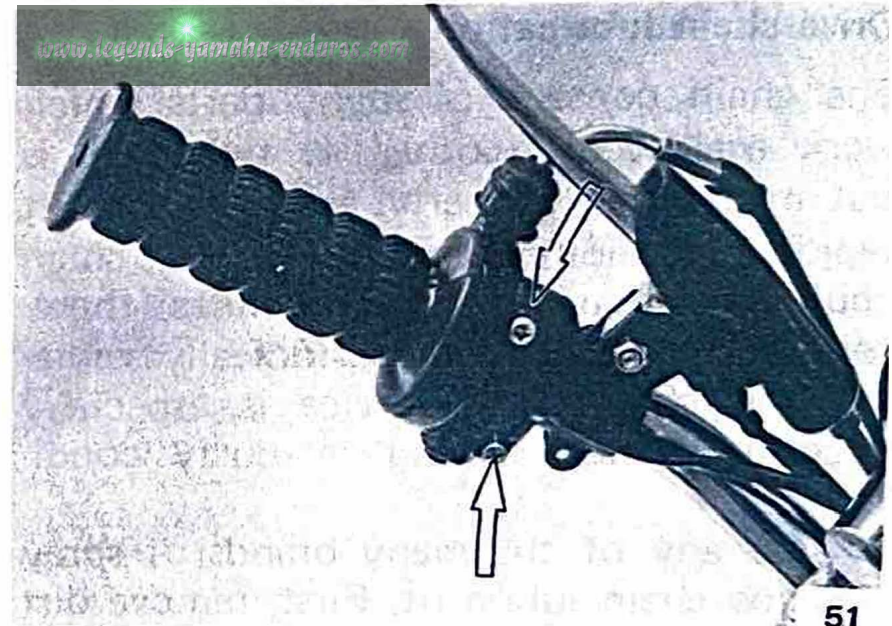

## Steering inspection

Periodically inspect the condition of the steering. Worn out or loose steering bearings may be dangerous.

Place a block under the engine to raise the front wheel of the motorcycle off the ground; then hold the lower end of the front fork and try to move forward and backward. If any free play can be felt, ask a Yamaha dealer to inspect and adjust.

Inspection is easier if the front wheel is removed. Ask a dealer to lubricate the steering bearings every 2,000 miles (3,200 km) of operation (move often in cases of off-road operation).

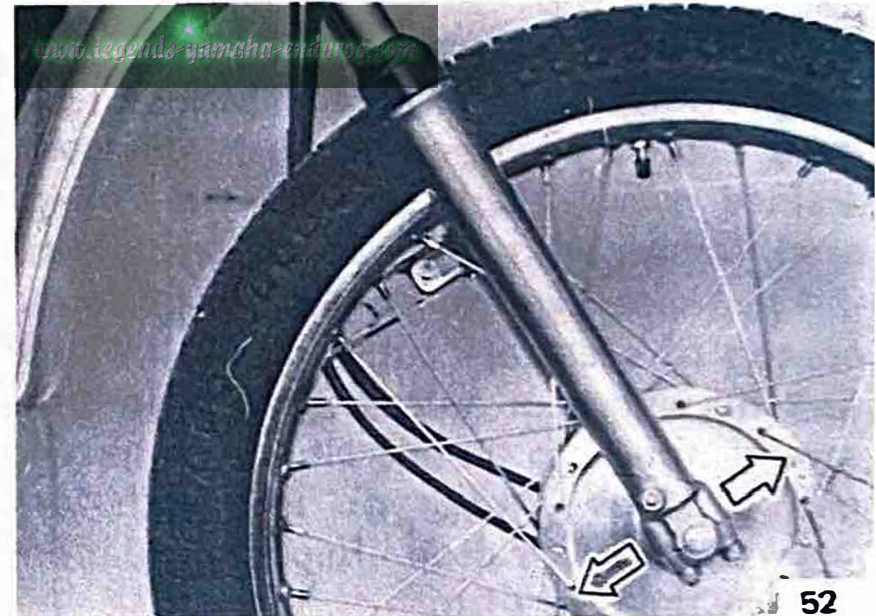

52

## Front fork

At least every 2,000 miles (3,200 km) the front fork oil should be completely drained and refilled. Remove the Phillips head screws in the very bottom of the forks. Next, remove the fork cap found on top of each fork tube and most of the fork oil will drain out. Compress the forks several times to pump all the remaining oil out. Slowly pour oil into each fork leg. (see Lubrication Recommendations section for type of oil).

At least every other time you should have your mechanic dismantle the fork assembly and thoroughly clean out each fork. Water and dirt eventually coat much of the inner for surfaces and cannot be readily removed just by draining.

Front fork oil quantity: 4.3 oz (128 cc) each leg
------------------------------------------------------

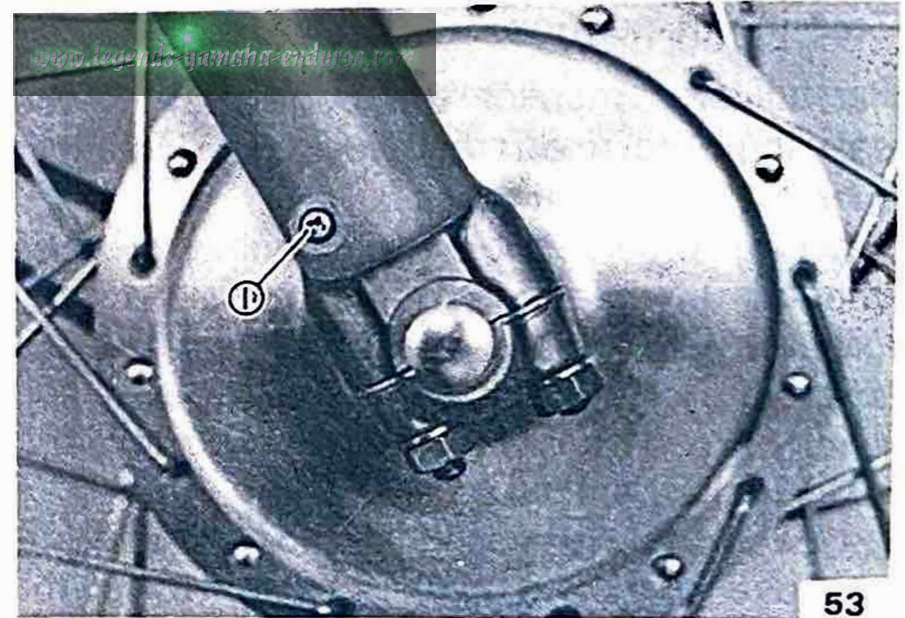

1. Oil drain screw

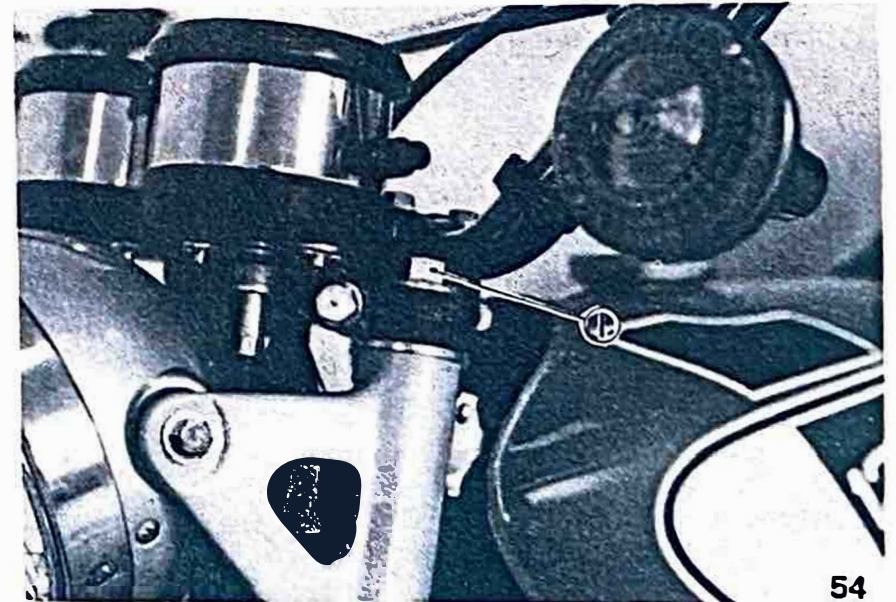

1. Fork cap



## Front wheel alignment

The only front wheel service that should be performed by the owner is air pressure inspection, tire wear inspection, tire and tube replacement, brake lining inspection, etc. Brake lining replacement, tightening spokes, hub replacement, etc., should be left to a Yamaha service technician.

## Front wheel removal

1. Remove speedometer cable from front brake shoe plate: First remove clip and then pull cable out.
2. Remove brake cable; loosen all cable adjusters and remove cable from handle lever holder. Then remove cable from cam lever at front brake shoe plate.
3. Remove cotter pin from front wheel axle and remove axle nut.
4. Loosen axle holder nuts at other end of axle.
5. Elevate the front wheel by placing a suitable stand under the engine.
6. Turn and pull out the front wheel axle; the wheel assembly can now be removed.

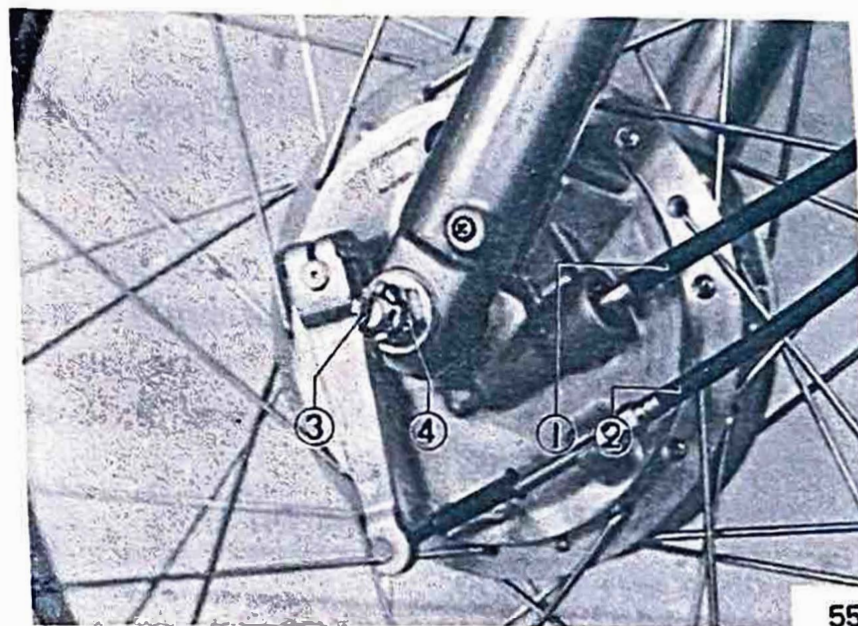

1. Speedometer cable 3. Cotter pin  
2. Front brake cable 4. Axle nut

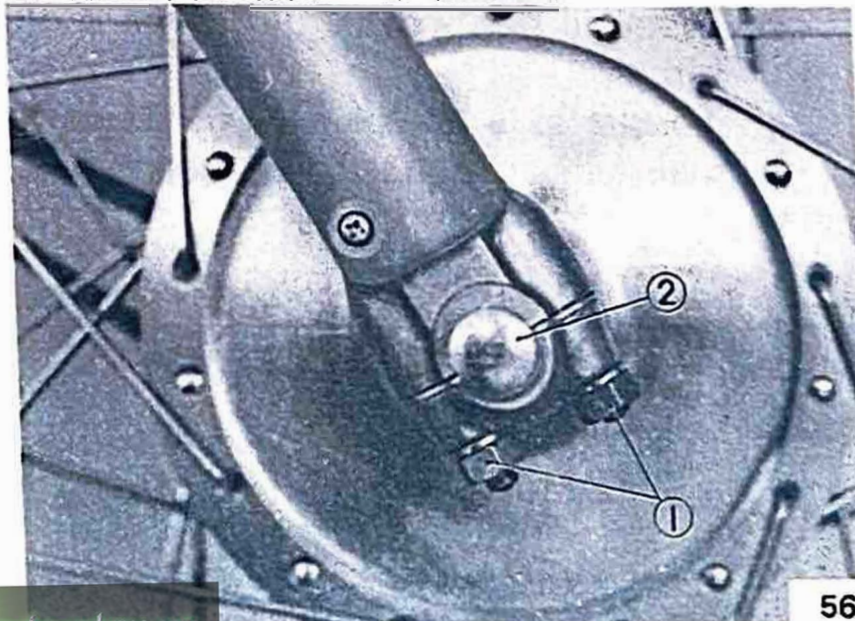

1. Holder nuts 2. Front wheel axle

## Front wheel installation

When installing front wheel, reverse the removal procedure taking care of the following points:

1. Check for proper engagement of the boss on the outer fork tube with the locating slot on the brake shoe plate.
2. Always secure the front wheel axle as follows:
  - a) Torque the front axle nut.

Axle nut torque:  
36–51 ft-lb (5.0–7.0 m-k<sub>g</sub>)

- b) Install a new cotter pin; discard old pin.
- c) Torque axle holder nuts in stages to maintain an equal gap on each side.

Holder nut torque:  
13–18 ft-lb (1.8–2.5 m-k<sub>g</sub>)

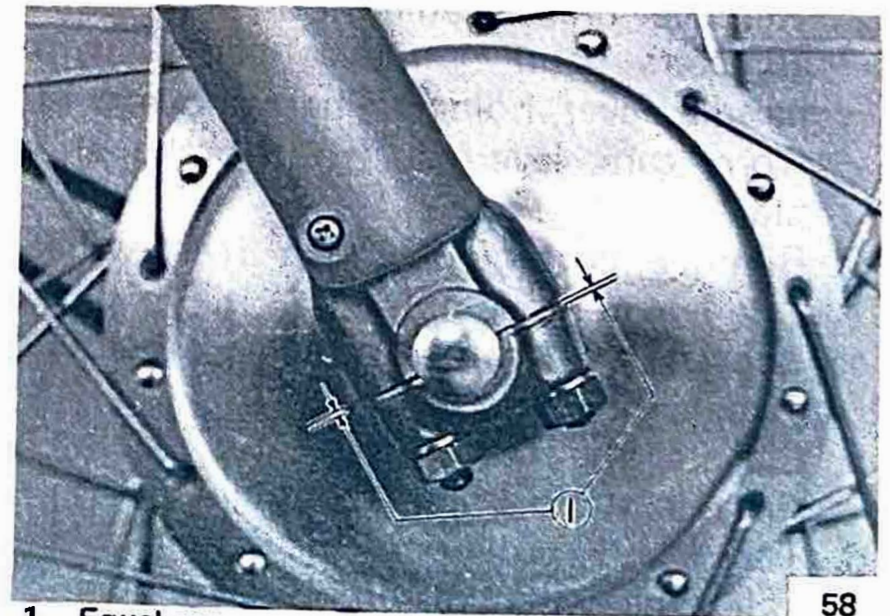
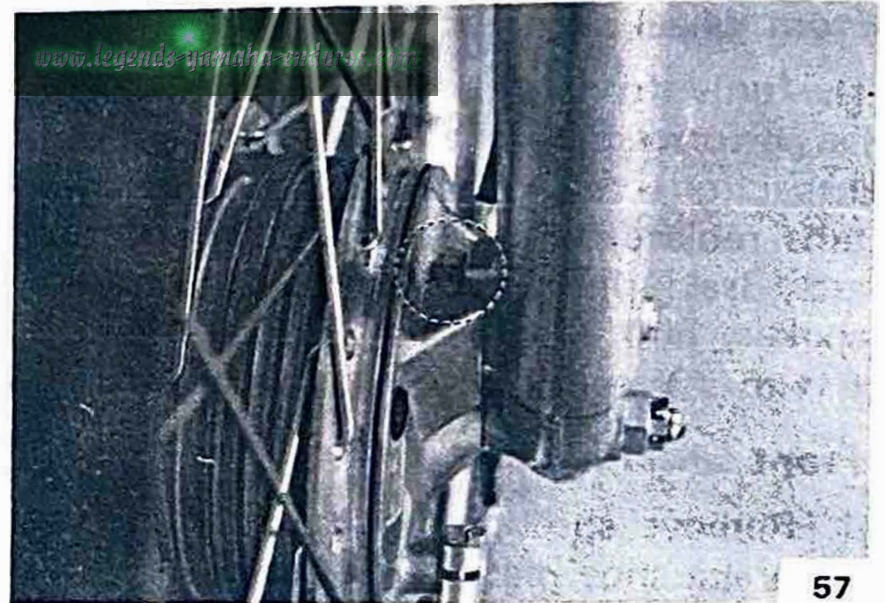

1. Equal gap

## Removing the rear wheel

1. Remove the tension bar and the brake rod from the brake shoe plate. The tension bar can be removed by removing cotter pin and nut from the tension bar bolt. The brake rod can be removed by removing the adjusting nut.
2. Loosen the locknuts of the left and right chain pullers and loosen the adjusting bolts.
3. Remove the master link clip and master link and remove the chain from the rear sprocket.
4. Remove the cotter pin from the wheel shaft and loosen the rear wheel axle nut.
5. The rear wheel assembly, the collar, the chain pullers, etc., can be removed from the motorcycle by pulling out the wheel axle.

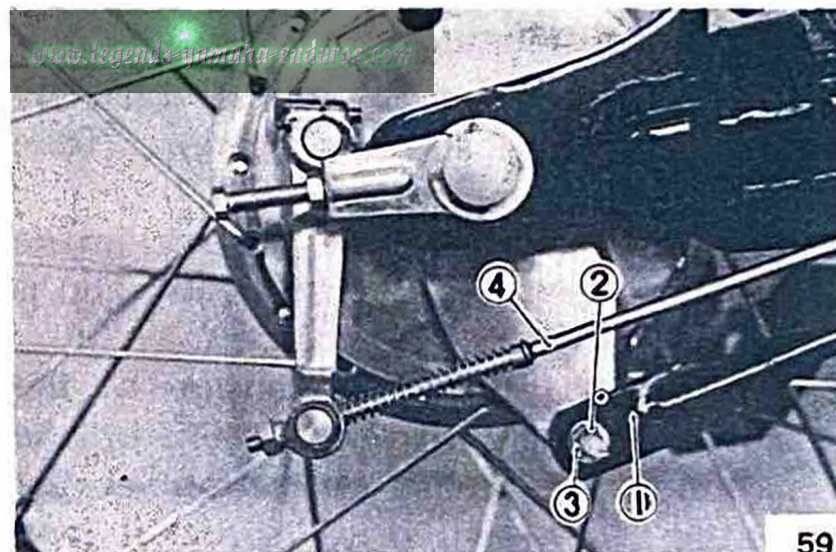

- |                |              |
|----------------|--------------|
| 1. Tension bar | 4. Brake rod |
| 2. Cotter pin  | 5.           |
| 3. Nut         |              |

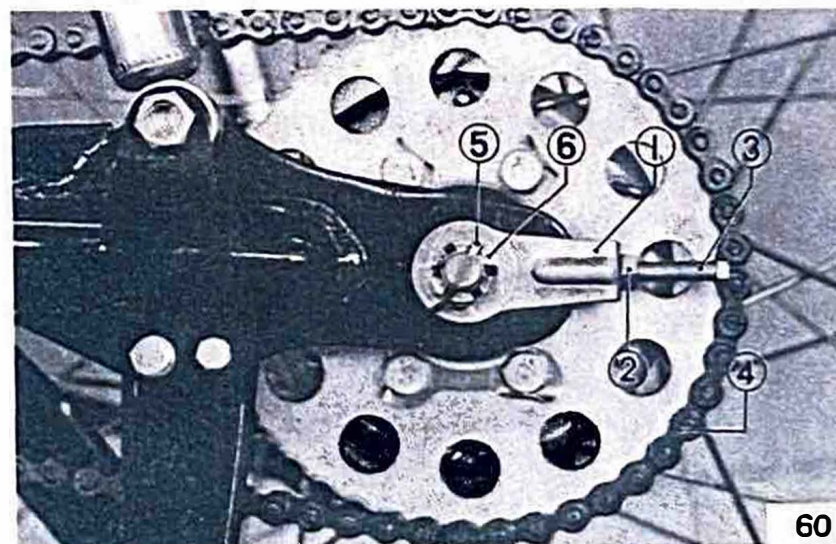

- |                   |                        |
|-------------------|------------------------|
| 1. Chain puller   | 4. Drive chain         |
| 2. Lock nut       | 5. Cotter pin          |
| 3. Adjusting bolt | 6. Rear wheel axle nut |

## Rear wheel installation

The rear wheel can be reassembled by reversing the disassembly procedure. Take care of the following points.

1. When connecting the chain, make certain closed end of master link clip is facing direction of rotation.
2. Be sure to adjust the tension of the chain. Adjust with both wheels on the ground. The chain deflection at the center (between drive sprocket and rear sprocket) should be adjusted to 3/4 in (20 mm). (Page 48)
3. Position the chain pullers at corresponding marks on the rear arms to maintain rear axle alignment. (Page 48).
4. Adjust the brake pedal and stoplight switch. (Page 46, 47)
5. Always use a new cotter pin. Old pins should be discarded.

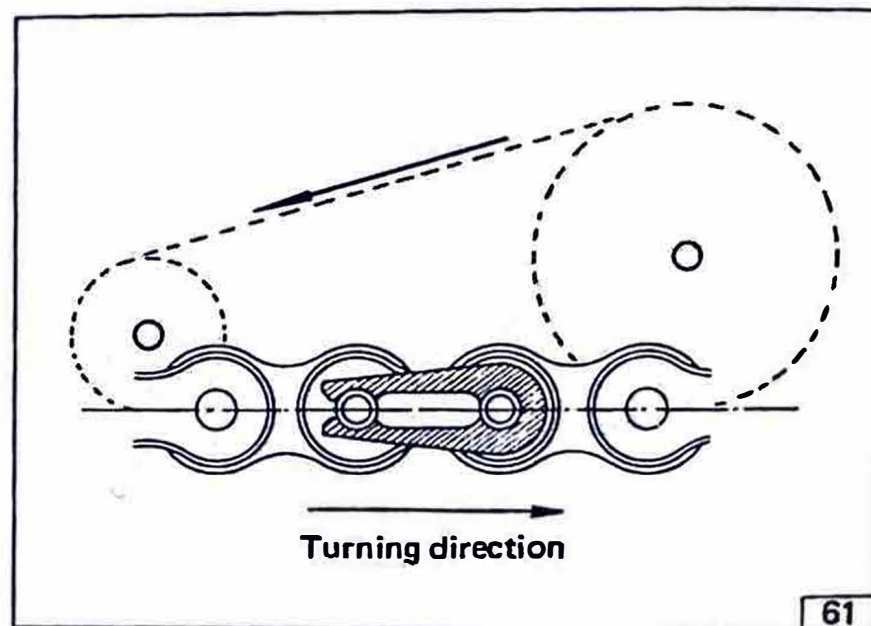

## Brake shoe inspection

Measure the outside diameter of the brake shoe set with slide calipers.

If it measures less than specified, replace the shoes, smooth out any rough shoes surface with sandpaper.

Brake shoe diameter	Standard	Wear Limit
Front Brake	5.12 in. (130 mm)	4.92 in. (125 mm)
Rear Brake	5.12 in. (130 mm)	4.92 in. (125 mm)

## Brake drum inspection

The friction between the inner surface of the brake drum and the brake lining provides the energy to stop the motorcycle. If these become damaged or if oil contacts the drum, noise may occur and brake performance will suffer. Check the inner surface of the brake drum and remove any scratches with emery cloth. Remove any oil with a cloth dipped in solvent. If damage is more extensive, have a Yamaha dealer replace the wheel hub.

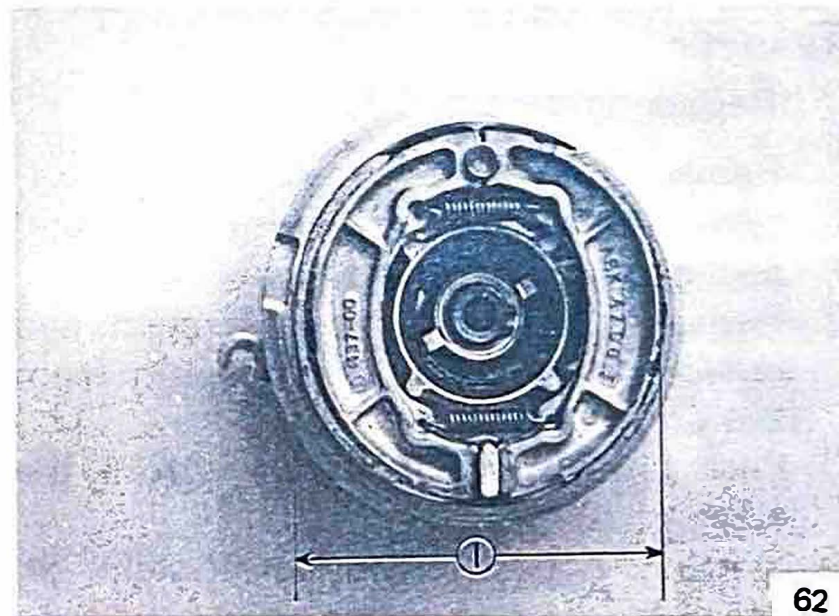

1. Brake shoe outside diameter

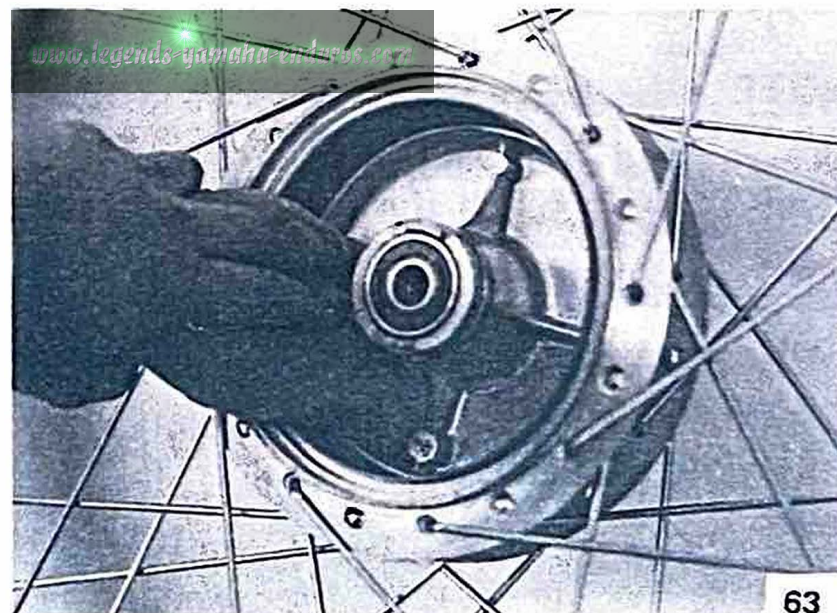

## Tire repair

### A. Removing the tire

1. Remove the wheel from the motorcycle (see page 54 for front wheel and page 56 for rear wheel)
2. Remove locknut from valve stem and release as much air as possible from the tire.
3. Push both tire beads away from the edges of the rim.
4. Starting opposite the valve stem on one side, use two round-ended tire iron to work the bead off the rim.

### NOTE: \_\_\_\_\_

Use a tire removal lubricant and be careful not to pinch the tube with the tire irons.

---

5. Remove the valve stem from its hole and remove the tube.
6. Remove the rim band.

7. If the tire is to be changed, remove the second bead from the rim using the tire irons and tire lubricant.

### B. Inspection

1. Use a cloth to check for nails or other sharp objects in the tire.

### CAUTION: \_\_\_\_\_

Always use a cloth to avoid cutting your hand.

---

2. Check for faults in the side wall. If there is any fault, the tire should be replaced as a damaged tire may burst at high speed, which is extremely dangerous.
3. Inflate the tube with air and check the valve stem and the tube for damage and leakage. Replace as required. Some leaks can be patched in an emergency, but it is best to replace tube.
4. Inspect rim band and replace if damaged.

## C. Reassembly

1. Install the rim band on the rim.
2. Install one tire bead on the rim using tire irons and lubricant and then install the tube.
3. Inflate tube with air to about one-third the specified pressure. Hit the outer circumference of the tire with a soft hammer to make certain the tube is not caught between tire and rim. Release air from tube.
4. Install second tire bead starting opposite the valve stem using tire irons and tire mounting lubricant.
5. Inflate tire to approximately 30 psi and then reduce pressure to specified setting.
6. Tighten the valve stem locknut.

## NOTE:

Check the valve stem; it must be pointing directly at center of wheel hub. If angled in any direction, release air and adjust tube position.

## Tire air pressure

Improper tire pressure affects the smoothness of the tire, traction, handling and the life of the tires. Always maintain the proper the pressure.

	Front tire	Rear tire
Normal riding on paved roads	24 lb/in <sup>2</sup> (1.7 kg/cm <sup>2</sup> )	28 lb/in <sup>2</sup> (2.0 kg/cm <sup>2</sup> )
Normal riding off-road	14 lb/in <sup>2</sup> (1.0 kg/cm <sup>2</sup> )	17 lb/in <sup>2</sup> (1.2 kg/cm <sup>2</sup> )

## Rim and spokes

There are checks that you can perform to determine if wheel work is necessary for your dealer to do. First, check for any loose spokes. This can be checked by bracing the front end off the ground so that the front wheel can spin free. Slowly revolve the front wheel and at the same time let the metal shaft of a fairly heavy screwdriver bounce off each spoke. If all the spokes are tightened approximately the same, then the sound given off by the screwdriver hitting the spokes should sound the same.

If one spoke makes a dull flat sound, then check it for looseness. While you have the front end up in the air, you should check

that the front wheel does not have too much run-out. "Run-out" is the amount the front wheel deviates from a straight line as it spins. Secure the front forks from turning, spin the front wheel, and solidly anchor some sort of a pointer about 1/8 in away from the side of the rim.

As the wheel spins, the distance between the pointer and the rim should not change more than 1/16 in total. Any greater fluctuation means that you should have your dealer remove this rim warpage by properly adjusting the spokes.



## Headlight beam adjustment

When necessary, adjust the headlight beam as follows.

1. Adjust horizontally by tightening or loosening the adjusting screw.

To adjust to the right: tighten the screw.

To adjust to the left: loosen the screw.

2. Adjust vertically by loosening the two nuts holding the body.

- a) Remove the anchor screw holding the headlight rim and remove the rim by prying lightly with a screwdriver at the gap provided at the bottom of the headlight.

**NOTE:** \_\_\_\_\_

Take care not to damage the headlight.

- b) Slightly loosen the two headlight mounting nuts and refit the rim to the headlight body.



1. Adjusting screw

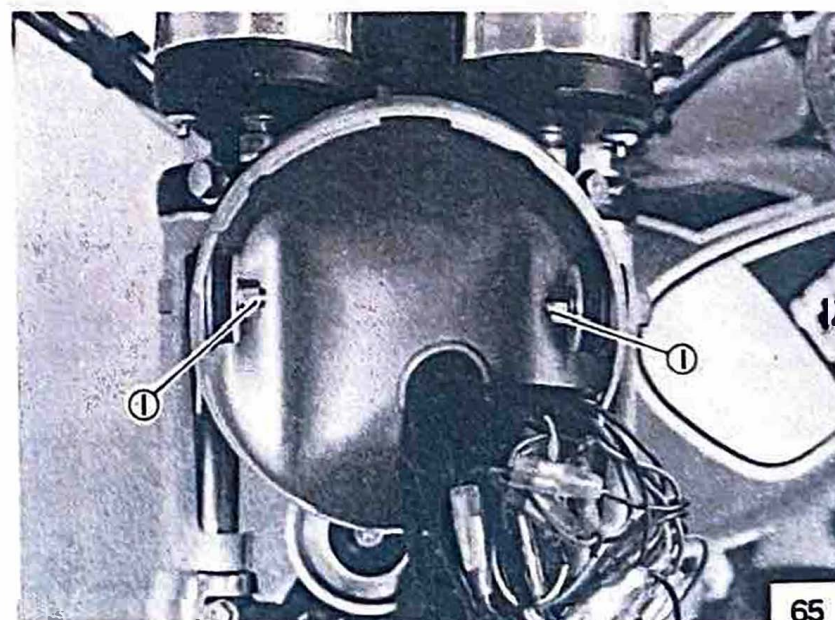

1. Headlight mounting

**NOTE:** \_\_\_\_\_

Do not tighten the another screw yet.

---

- c) Next, adjust vertically by moving the headlight body. When adjustment is complete hold the body in place, remove the rim and tighten the two mounting nuts. Then refit the rim to the headlight body.

### **Replacing the headlight bulb**

This motorcycle is equipped with a sealed beam headlight. If the headlight burns out, ask your Yamaha dealer for a lens unit replacement and adjustment.

### **Troubleshooting**

Although Yamaha motorcycles are given a rigid inspection before shipment from the factory, trouble may occur in operation. If this happens check the motorcycle in accordance with the procedures given in the troubleshooting chart below. If repair is necessary, ask your Yamaha dealer.

The skilled technicians at your Yamaha dealer provide excellent service. For replacement parts, use only genuine Yamaha Parts. Imitation parts are similar in shape but often inferior in quality of materials and workmanship, consequently, service life is shorter and more expensive repairs may be necessitated.

Any fault in the fuel, compression or ignition systems can cause poor starting or loss of power while driving. The troubleshooting chart describes quick and easy procedures for checking these systems.

## Troubleshooting (Continued)

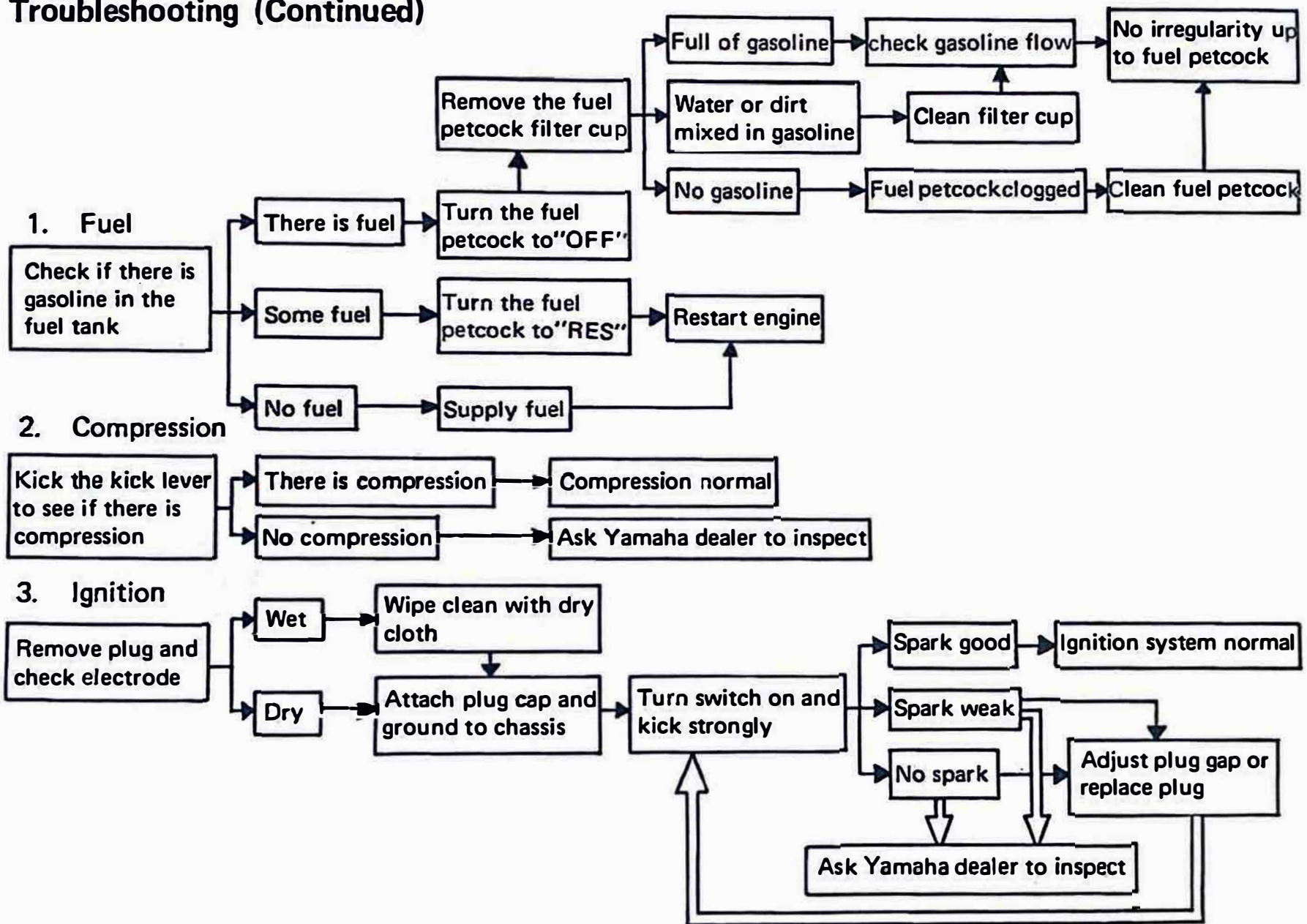

## REQUIREMENTS FOR A GOOD MOTORCYCLIST

1. Safety is more important than speed. Always observe traffic regulations and signs.
2. Always use quality gasoline and oil, and avoid the inconvenience of running out of gas or oil.
3. Check the pressures before every ride.
4. Warm up the engine for about one minute before riding.
5. Shift gears gently, while momentarily closing the throttle, avoid power shifting.
6. During the break-in period, ride at the suggested speed in each gear.
7. Apply the front and the rear brake at the same time.
8. Down a long hill, use engine compression as a brake.
9. When parking, be sure to turn off and remove the Ignition key, turn off the fuel petcock, and lock the steering.
10. Check parts at regular intervals as described in this manual.

## CLEANING AND STORAGE

### A. CLEANING

Frequent thorough cleaning of your motorcycle will not only enhance its appearance but will improve general performance and extend the useful life of many components.

1. Before cleaning the machine:
  - a) Block off end of exhaust pipe to prevent water entry; a plastic bag and strong rubber band may be used.
  - b) Remove air cleaner or protect it from water with plastic covering.
  - c) Make sure spark plug(s), gas cap, oil tank cap, transmission oil filler cap are properly installed.
2. If engine case is excessively greasy, apply degreaser with a paint brush. Do not apply degreaser to chain, sprockets, or wheel axles.

3. Rinse dirt and degreaser off with garden hose, using only enough hose pressure to do the job. Excessive hose pressure may cause water seepage and contamination of wheel bearings, front forks, brake drums, and transmission seals. Many expensive repair bills have resulted from improper high pressure detergent applications such as those available in coin-operated car washes.
4. Once the majority of the dirt has been hosed off, wash all surfaces with warm water and mild, detergent-type soap. An old tooth brush or bottle brush is handy to reach hard-to-get-to places.
5. Rinse machine off immediately with clean water and dry all surfaces with a chamois, clean towel, or soft absorbent cloth.
6. Immediately after washing, remove excess moisture from chain and lubricate to prevent rust.
7. Chrome-plated parts such as handlebars, rims, spokes, forks, etc., may be further cleaned with automotive chrome cleaner.
8. Clean the seat with a vinyl upholstery cleaner to keep the cover pliable and glossy.
9. Automotive-type wax may be applied to all painted and chrome-plated surfaces. avoid combination cleaner-waxes. Many contain abrasives which may mar paint or protective finish on fuel and oil tanks.
10. After finishing, start the engine immediately and allow to idle for several minutes.

## B. STORAGE

Long term storage (30 days or more) of your motorcycle will require some preventive procedures to insure against deterioration.

After cleaning machine thoroughly, prepare for storage as follows:

1. Drain fuel tank, fuel lines, and carburetor float bowl(s).
2. Remove empty fuel tank, pour a cup of 10W to 30W oil in tank, shake tank to coat inner surfaces thoroughly and drain off excess oil. Re-install tank.
3. Remove spark plug(s), pour about one tablespoon of 10W to 30W oil in spark plug hole(s) and re-install spark plugs. Kick engine over several times (with ignition off) to coat cylinder walls with oil.
4. Remove drive chain. Clean thoroughly with solvent and lubricate. Re-install chain or store in a plastic bag (tie to frame for safe-keeping).
5. Lubricate all control cables.

6. Block up frame to raise both wheels off ground: (Main stands can be used on machines so equipped.)
7. Deflate tires to 15 psi.
8. Tie a plastic bag over exhaust pipe outlet(s) to prevent moisture entering.
9. If storing in humid or salt-air atmosphere, coat all exposed metal surfaces with a light film of oil. Do not apply oil to rubber parts or seat cover.

Remove battery and charge. Store in a dry place and re-charge once a month. Do not store battery in an excessively warm or cold place (less than 32°F or more than 90°F).

**NOTE:** \_\_\_\_\_

Make any necessary repairs before storing the motorcycle.

---

# MISCELLANEOUS

## Consumer Information

### Stopping Distance

This figure indicate braking performance that can be met or exceeded by the vehicles to which it applies, without locking the wheels, under different conditions of loading and with partial failures of the braking system. The information presented represents results obtainable by skilled drivers under controlled road and vehicle conditions, and the information may not be correct under other conditions.

Description of vehicles to which this table applies: Yamaha motorcycle DT125C

#### A. Fully Operational Service Brake

Load

Light

Maximum

183

208

0 100 200 300

Stopping Distance in Feet from 60 mph.

## Acceleration and passing ability

This figure indicates passing times and distances that can be met or exceeded by the vehicles to which it applies, in the situations diagrammed below. The low-speed pass assumes an initial speed of 20 mph and a limiting speed of 35 mph. The high-speed pass assumes an initial speed of 50 mph and a limiting speed of 80 mph.

**NOTE:** \_\_\_\_\_

The information presented represents results obtainable by skilled drivers under controlled road and vehicle conditions, and the information may not be correct under other conditions.

Description of vehicles to which this table applies: Yamaha motorcycle DT125C

Summary table:

Low-speed pass ..... 380 feet; 8.2 seconds  
 High-speed pass ..... 1,990 feet; 23.6 seconds

**LOW-SPEED**

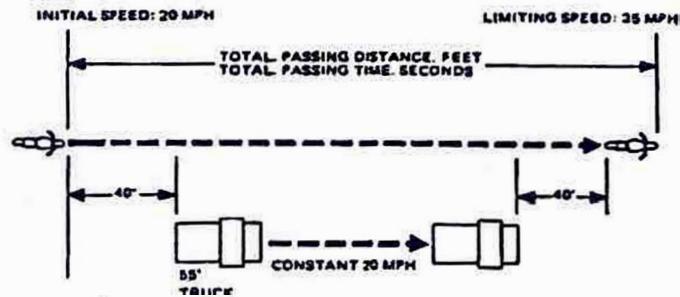

**HIGH-SPEED**

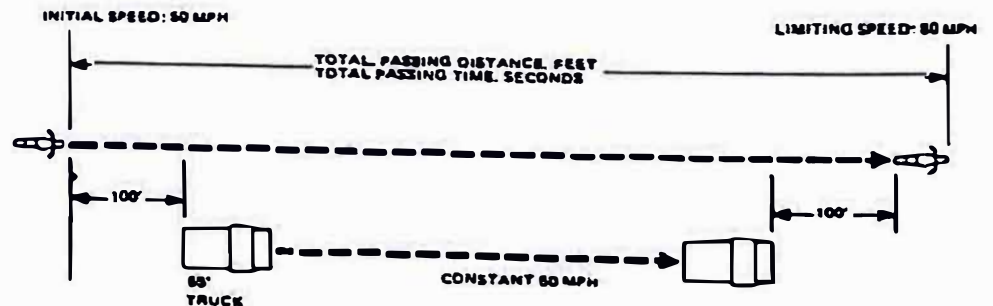



## WARRANTY INFORMATION

Study your Owner's Warranty Guide Book thoroughly. It contains your Warranty Policy, an explanation of the policy, break-in procedures and the recommended service schedules. Becoming familiar with these items will be to your advantage in making the best use of Yamaha's warranty program.

The acceptance of any warranty claim that your dealer might submit in the future depends greatly on just what has been done to the motorcycle. **IF ANY PARTICULAR FAILURE CAN BE TRACED DIRECTLY TO A REPAIR OR MAINTENANCE PERFORMED INCORRECTLY, THE WARRANTY CLAIM MAY NOT BE ACCEPTED.** For this reason, we recommended that all services beyond those detailed in this manual be performed by a qualified mechanic at an authorized Yamaha dealer.

There are certain requirements that must be met to qualify for warranty coverage.

1. Your machine must be registered for warranty. This is accomplished when the Warranty Registration card is filled out by you and mailed by the dealer to Yamaha International at the time of purchase.
2. Your Owner's Warranty Guide Book outlines the owner-responsibility service schedules and provides a maintenance record for your protection and convenience. Proper maintenance will insure a trouble free life for your new Yamaha.
3. If any problems occur which you feel should be covered under warranty, **NOTIFY YOUR DEALER IMMEDIATELY.** Do not delay, as little problems left unrepaired can become large problems which may not be covered under warranty.

## SPECIFICATIONS

<b>Model</b>	<b>YAMAHA ENDURO DT125C</b>	
<b>Dimension</b>	<b>Overall length</b>	<b>80.5 in. (2,040 mm)</b>
	<b>Overall width</b>	<b>33.9 in. ( 860 mm)</b>
	<b>Overall height</b>	<b>42.9 in. (1,090 mm)</b>
	<b>Wheelbase</b>	<b>52.2 in. (1,325 mm)</b>
	<b>Minimum road clearance</b>	<b>9.8 in. ( 250 mm)</b>
<b>Weight</b>	<b>Net</b>	<b>230 lb. (104.5 kg)</b>
<b>Performance</b>	<b>Minimum turning radius</b>	<b>82.7 in. (2,100 mm)</b>
	<b>Braking distance</b>	<b>49.2 ft at 31 mph (15 m at 50 km/h)</b>
<b>Engine</b>	<b>Type</b>	<b>Air-cooled, 2-stroke, gasoline, Torque induction</b>
	<b>Engine model</b>	<b>560</b>
	<b>Cylinder</b>	<b>Single, Forward inclined</b>
	<b>Displacement</b>	<b>7.51 cu.in. (123 cc)</b>
	<b>Bore &amp; Stroke</b>	<b>2.205 in. x 1.969 in. (56 mm x 50 mm)</b>
	<b>Compression ratio</b>	<b>7.1 : 1</b>
	<b>Starting system</b>	<b>Primary kick, electric starter</b>
	<b>Ignition system</b>	<b>Battery</b>
	<b>Fuel tank capacity</b>	<b>1.8 US gal (7.0ℓ)</b>
	<b>Oil tank capacity</b>	<b>1.3 US qt (1.2ℓ)</b>

	Lubricating system	Separate lubrication (Yamaha Autolube)
	Battery capacity	12V, 7AH
	Battery type	12N7-3B or 12N7-3B-1
	Generator system	Starter generator
	Generator type	GS—X170
	Generator manufacturer	Hitachi
	Spark plug	NGK (B-8ES) x 1
	Carburetor	(VM24SS) x 1
	Air cleaner	Wet, foam rubber
Transmission	Primary reduction system	Gear
	Primary reduction ratio	74/19 3.894
	Secondary reduction system	Chain
	Secondary reduction ratio	45/15 3.000
	Clutch	Wet, multi-disc type
	Gear box type	Constant mesh, 5 speed
	Operating system	Left foot operated, return system
	Gear ratio	First
		Second
		Third
	Fourth	
	Fifth	
Steering	Caster	58.0 degrees
	Trail	5.55 in. (141 mm)

<b>Tire size (Tire pattern)</b>	<b>Front</b>	<b>2.75–21–4PR (Trials Universal tire)</b>
	<b>Rear</b>	<b>3.25–18–4PR (Trials Universal tire)</b>
<b>Suspension system</b>	<b>Front</b>	<b>Telescopic fork, Coil spring, Oil damper</b>
	<b>Rear</b>	<b>Swing arm, Coil spring, Oil damper</b>
<b>Frame</b>	<b>Double cradle-type, high tensil tube frame</b>	
<b>Lights</b>	<b>Headlight</b>	<b>12V, 30W/30W</b>
	<b>Taillight</b>	<b>12V, 8W</b>
	<b>Stoplight</b>	<b>12V, 27W</b>
	<b>Flasherlights</b>	<b>12V, 27W</b>
	<b>Pilot light F (Flasher pilot light)</b>	<b>12V, 3W</b>
	<b>H (High beam)</b>	<b>12V, 3W</b>
	<b>N (Neutral pilot light)</b>	<b>12V, 3W</b>
	<b>Meterlights</b>	<b>(12V, 3W) x 2</b>
<b>Meter system</b>	<b>Separate type, tachometer and speedometer</b>	

# DT125C WIRING DIAGRAM

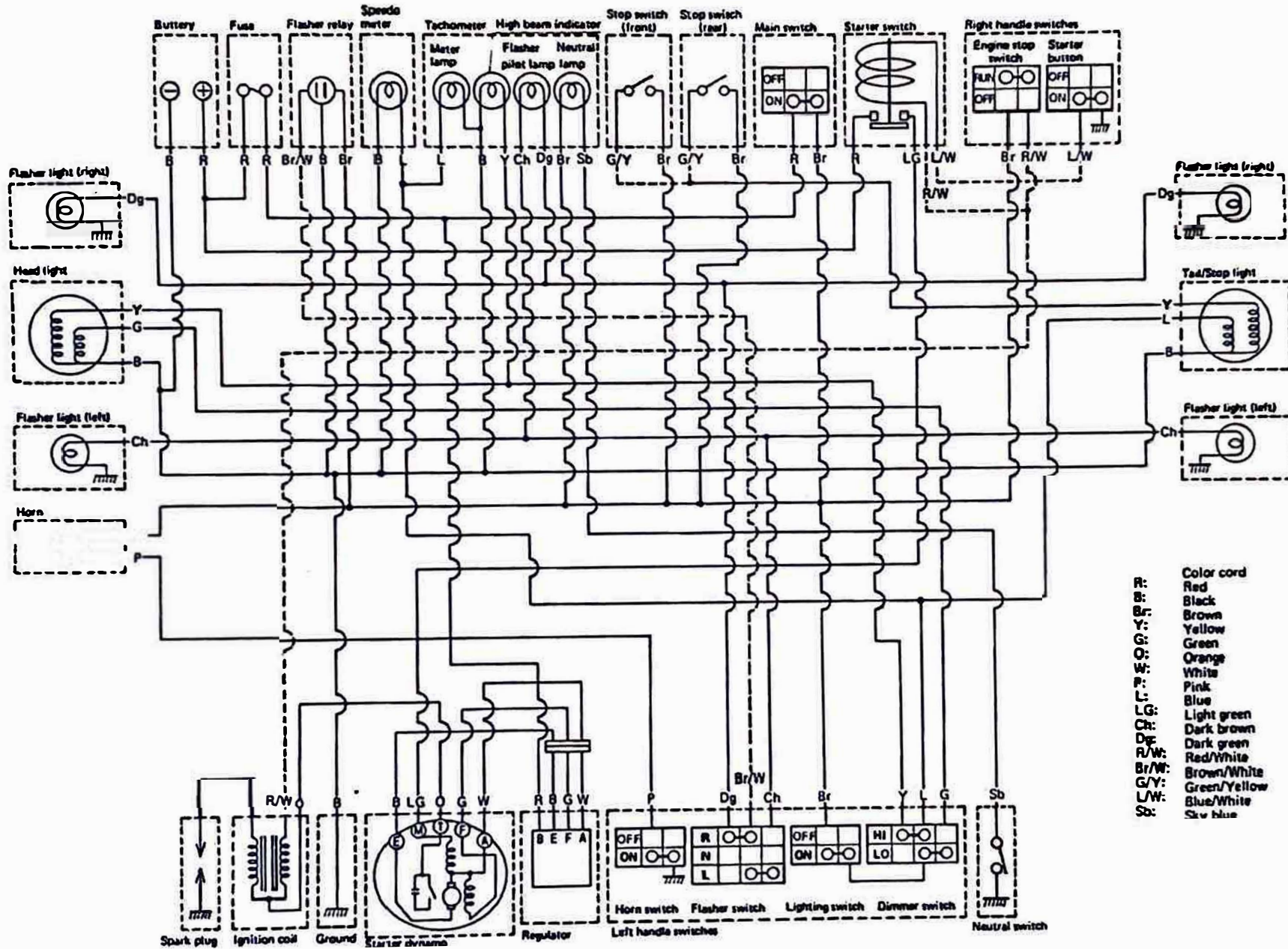

MEMO

MEMO

MEMO



[www.legends-yamaha-enduros.com](http://www.legends-yamaha-enduros.com)

LIT-11626-00-05