



# YAMAHA

## PARTS LIST

MODEL **YZ125E**

[www.legends-yamaha-enduros.com](http://www.legends-yamaha-enduros.com)

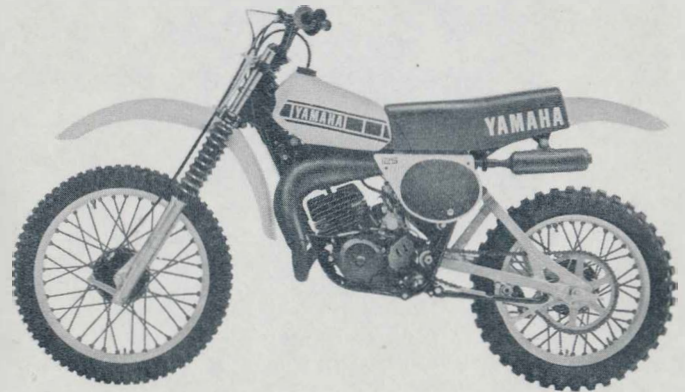
**YAMAHA MOTOR CO., LTD.**

COPY RIGHT: ALL RIGHTS RESERVED

NO PART OF THIS PUBLICATION MAY BE REPRODUCED WITHOUT PERMISSION.

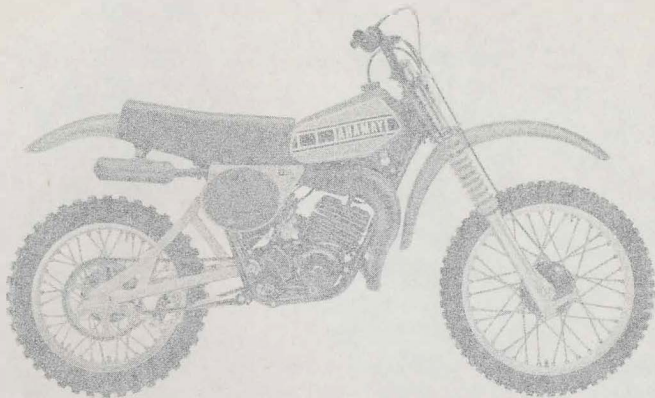


YZ125E



YZ125E (EUROPE • OCEANIA • JAPAN)

[www.legends-yamaha-enduros.com](http://www.legends-yamaha-enduros.com)



YZ125E



YZ125E (EUROPE • OCEANIA • JAPAN)

## FOREWORD

This Parts List relates to the parts in use for the Yamaha YZ125E. When you are ordering replacement parts for the YZ125E, refer to this Parts List and quote both part numbers and part names correctly.

### 1. Structure of Part No.

Yamaha parts are divided largely into two categories; general parts and standard parts, and each part No. has the following structure:

General Parts ○○○ - ○○○○○○ - ○○ - ○○

Model code No. \_\_\_\_\_

Basic code No. \_\_\_\_\_

Design code No. \_\_\_\_\_

Design change code No. \_\_\_\_\_

Color code No. \_\_\_\_\_

Standard Parts ⑨ ○○○○○○ - ○○○○○○

Major classification \_\_\_\_\_

Type \_\_\_\_\_

Material, surface finish \_\_\_\_\_

Shape, size \_\_\_\_\_

Note: Every standard No. begins with 9.

### 2. How to Use this Parts List

(1) Except for steel balls (whose size is indicated in inches), the size of all parts is indicated in millimeters in the following manner.

- Hose (rubber or vinyl) ..... Inside diameter - length
- O-ring ..... Section area - inside diameter
- Washer, shim, collar ..... Inside diameter - outside diameter - thickness (length)

(2) Parts, which are to be supplied in the form of assemblies, are listed with an indentation of one letter's space, and a dot (.) is put

against the name of each part. If any two different assemblies (e. g. , right and left side components) consist of almost the same type components, these two assemblies are listed in two lines, and then the names of component parts are listed in the subsequent lines with an indentation as mentioned earlier. The quantity of parts is given in the following manner; that is, in the case of parts being the same in type between the right and left, a total quantity of parts is given. On the other hand, if the right and left side parts are different in type, the quantity of part(s) on each side is given.

Example

Description	Q'ty
CARBURETOR ASS'Y, left	1
CARBURETOR ASS'Y, right	1
. JET, pilot	2
. NOZZLE, main	2
. LEVER, starter, left	1
. LEVER, starter, right	1

(3) Key to Symbols

U. R. ....	Use size (thickness) and/or number as required
U. N. ....	Use as many as you need
T .....	Number of teeth in a gear
V .....	Voltage for light bulbs
S .....	"S" type oil seal or "S" type circlip
SD .....	"SD" type oil seal
SO .....	"SO" type oil seal
SW .....	"SW" type oil seal
E .....	"E" type circlip
R .....	"R" type circlip
F/No. ....	Frame No. (Applicable machine No. )

- (4) The right and left in relation to parts are determined on the basis of the rider facing toward the front.
- (5) The parts marked with \* in the remark column of this list are not supplied with by Yamaha, those have to be found locally.
- (6) This Parts List is based on the model in the production line on Sept., 30, 1977. Accordingly, if any modifications which have been made to parts will be announced in the Yamaha Parts News. It is advisable that according to the Yamaha Parts News, You will make necessary corrections to the Parts List on hand to keep it up-to dated.

ENGINE

Fig. 1	Crankcase . Cylinder	Fig. 28	1
Fig. 2	Crankcase Cover		3
Fig. 3	Crank . Piston		5
Fig. 4	Clutch		7
Fig. 5	Transmission		9
Fig. 6	Shifter 1		13
Fig. 7	Shifter 2		15
Fig. 8	Kick Starter		17
Fig. 9	Intake		19
Fig. 10	Carburetor		21
Fig. 11	Exhaust		25
Fig. 12	C. D. I. Magneto		27

CHASSIS

Fig. 13	Frame . Side Cover		31
Fig. 14	Rear Arm		33
Fig. 15	Rear Cushion (Except Iran)		37
Fig. 16	Rear Cushion (Exclusive for Iran)		39
Fig. 17	Stand . Footrest . Brake Pedal		41
Fig. 18	Front Fender . Rear Fender		43
Fig. 19	Front Fork (Except Iran)		45
Fig. 20	Front Fork (Exclusive for Iran)		49
Fig. 21	Steering		53
Fig. 22	Handle . Wire		55
Fig. 23	Fuel Tank		59
Fig. 24	Seat		61
Fig. 25	Front Wheel		63
Fig. 26	Rear Wheel		65



Fig. 27 Electrical ..... 69

REPAIR KIT

Fig. 28 Repair Kit ..... 73

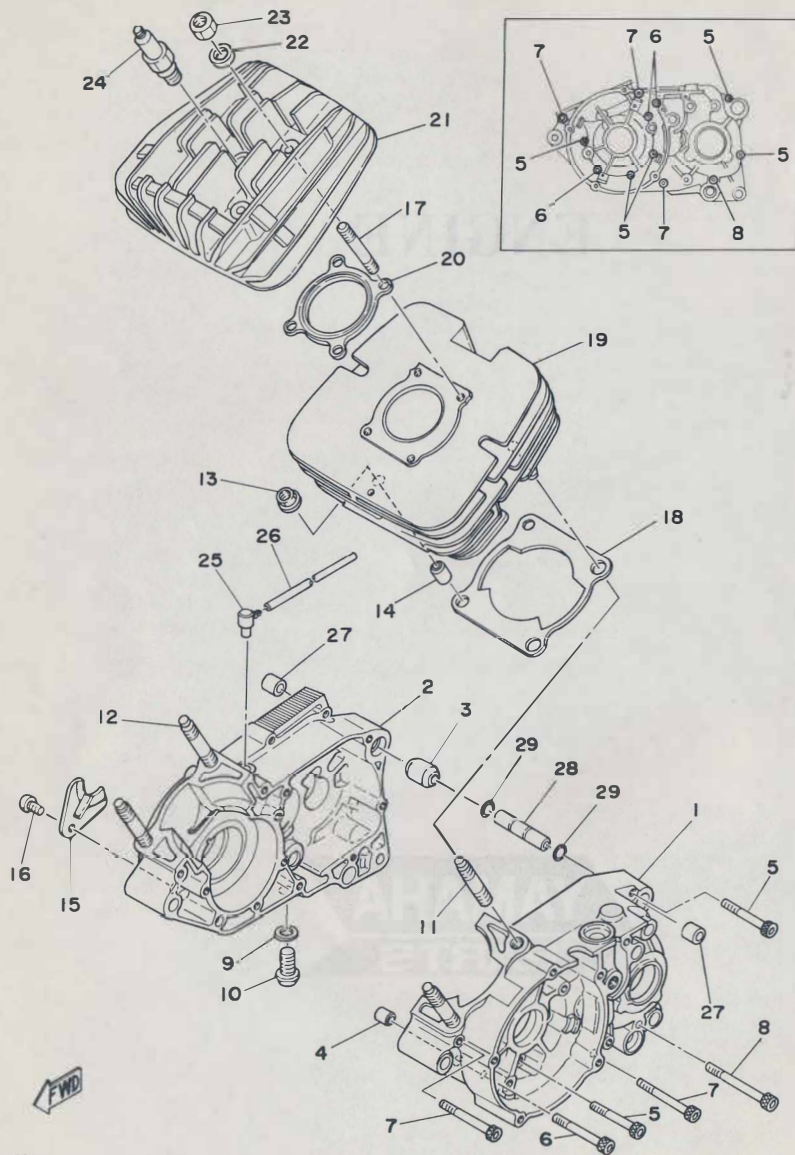
NUMERICAL INDEX

# ENGINE

[www.legends-yamaha-enduros.com](http://www.legends-yamaha-enduros.com)



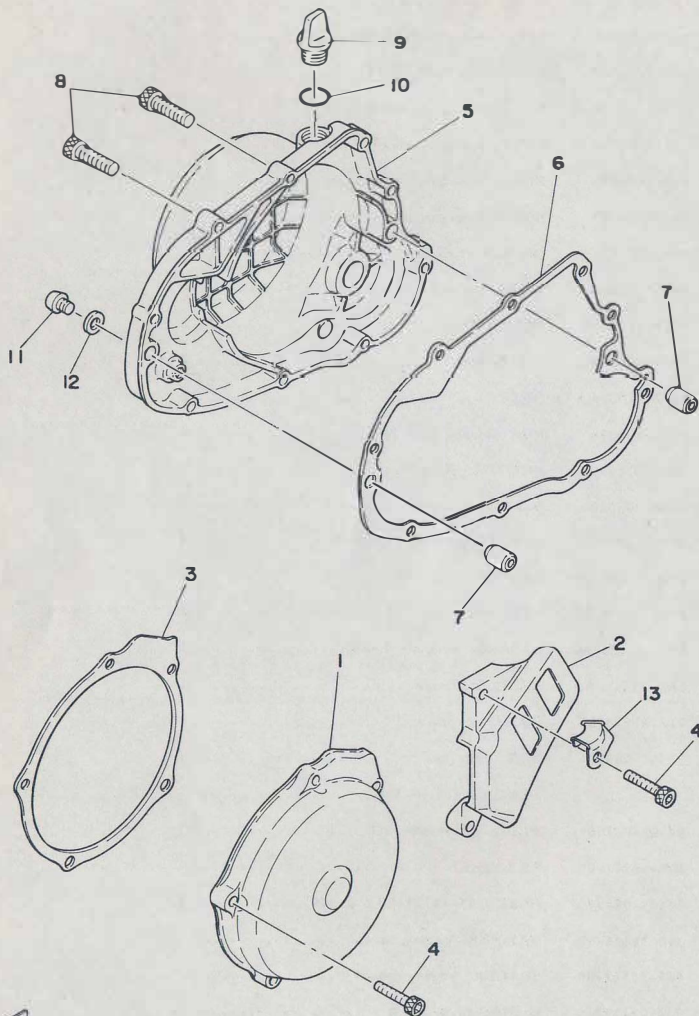
Fig. 1 CRANKCASE · CYLINDER



Ref. No.	Part No.	Description	Q'ty	Applicable Machine No.	Remarks
1- 1	1W1-15111-02	CASE, crank left	1		
2	1W1-15121-01	CASE, crank right	1		
3	91810-19020	PIN, dowel (16.5-20-20)	1		
4	91830-21014	PIN, dowel (6.4-10-14)	1		
5	91316-06050	BOLT, hexagon socket head	5		
6	91316-06060	BOLT, hexagon socket head	3		
7	91316-06070	BOLT, hexagon socket head	3		
8	91316-06075	BOLT, hexagon socket head	1		
9	90430-12038	GASKET (132-15353-00)	1		
10	90340-12005	PLUG, straight screw (132-15351-00)	1		
11	90116-10278	BOLT, stud	2		
12	90116-10279	BOLT, stud	2		
13	90179-10204	NUT	4		
14	91810-16016	PIN, dowel (10.5-14-16)	2		
15	304-15128-00	HOLDER, right	1		
16	92501-08010	SCREW, panhead	1		
17	90116-08104	BOLT, stud (363-11179-00)	4		
18	1W1-11351-00	GASKET, cylinder	1		
19	2K6-11311-00	CYLINDER	1		
20	1W1-11181-00	GASKET, cylinder head	1		
21	2K6-11111-00	HEAD, cylinder	1		
22	812-11175-00	WASHER, plate	4		
23	95301-08600	NUT, hexagon	4		
24	*	PLUG, spark (N-59G)	1		CHAMPION
		94703-00100	1		CHAMPION for Japan
25	498-15371-00	BREATHER	1		
26	90445-07177	HOSE (395-14197-00 4.2-310)	1		
27	328-15316-00	DAMPER, engine mount	2		
28	401-15317-00	SPACER, engine mount	1		
29	93210-11073	O-RING (2.4-10.8)	2		

# Fig. 2 CRANKCASE COVER

Lee Waldie Craig Scott Chris Koira

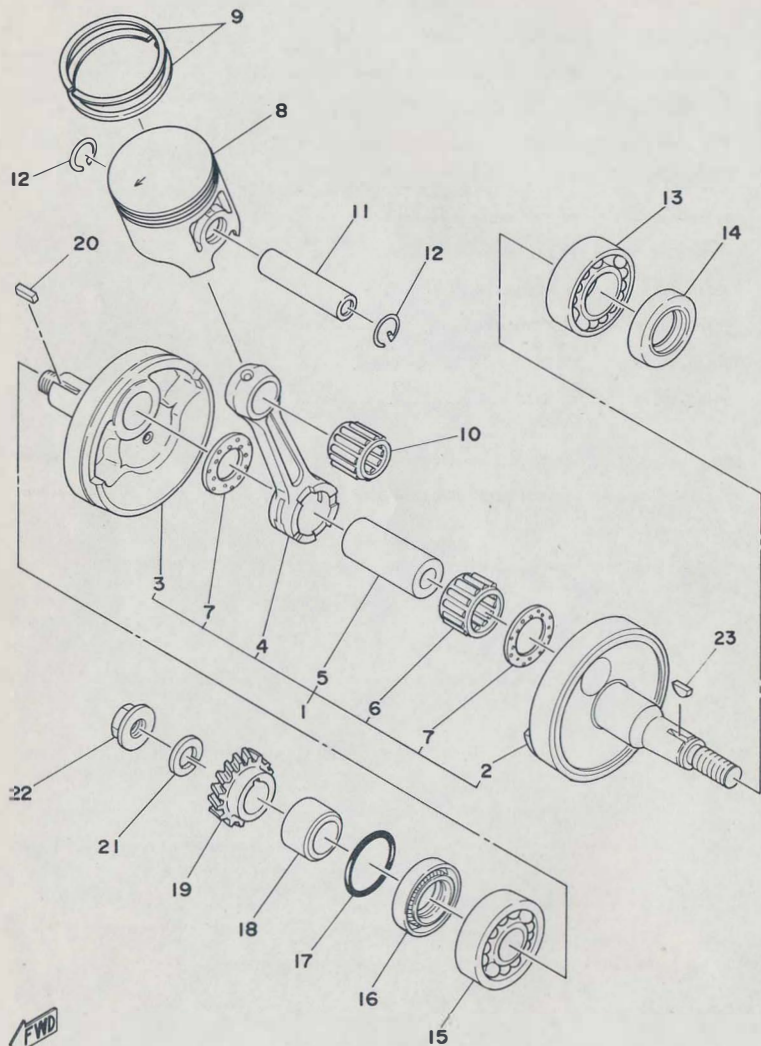


Ref. No.	Part No.	Description	Q'ty	Applicable Machine No.	Remarks
2-1	1W1-15411-00	COVER, crankcase left 1	1		
2	1W1-15421-01	COVER, crankcase left 2	1		
3	1W1-15455-00	GASKET, crankcase cover left	1		
4	91316-06030	BOLT, hexagon socket head	7		
5	1W1-15431-00	COVER, crankcase right	1		
6	1W1-15451-00	GASKET, crankcase cover right	1		
7	91830-21014	PIN, dowel (6.4-10-14)	2		
8	91316-06030	BOLT, hexagon socket head	9		
9	1G8-15362-00	PLUG, oil level	1		
10	93210-14104	O-RING (2.4-13.8)	1		
11	92506-66008	SCREW, panhead	1		
12	90430-06016	GASKET (838-15384-00)	1		
13	90465-10119	CLAMP	1		



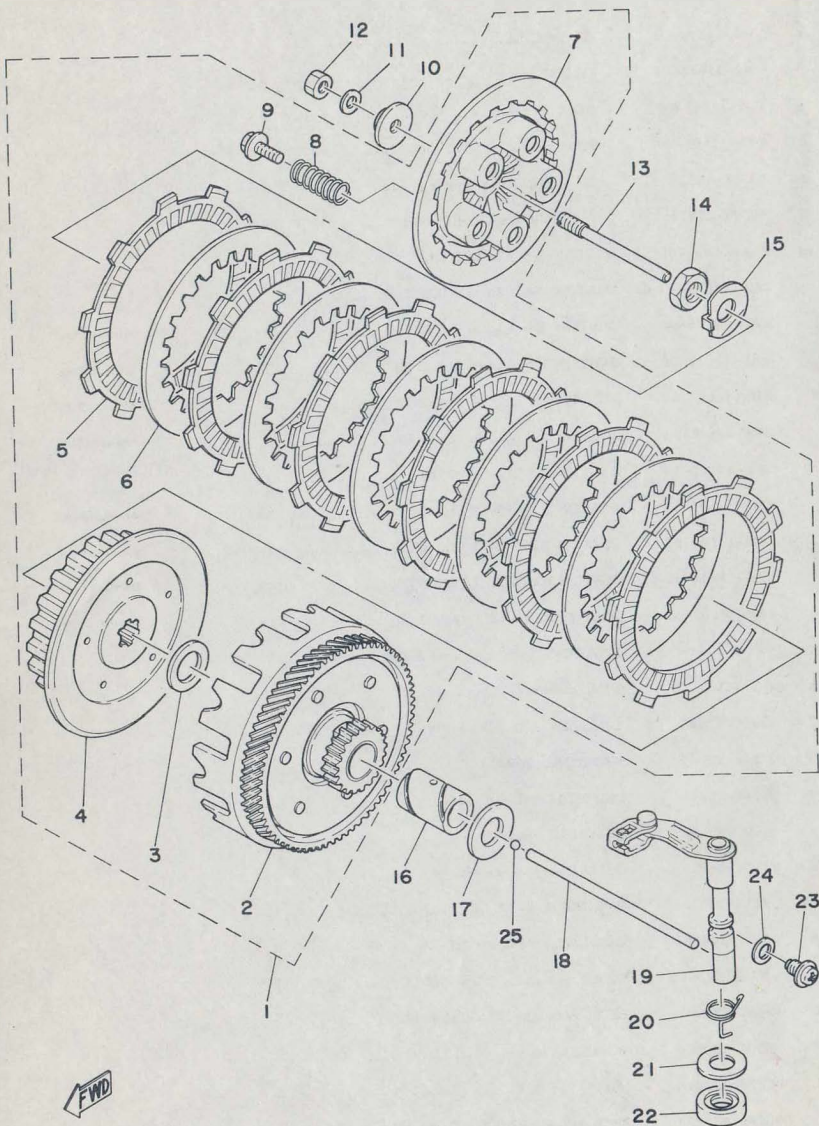


Fig. 3 CRANK · PISTON



Ref. No.	Part No.	Description	Q'ty	Applicable Machine No.	Remarks
3-1	2K5-11400-00	CRANK ASS'Y	1		
2	1W1-11412-01	CRANK, left	1		
3	1W1-11422-01	CRANK, right	1		
4	1G8-11651-00	ROD, connecting	1		
5	2K5-11681-00	PIN, crank	1		
6	93310-422E6	BEARING, con-rod big end	1		
7	90209-22071	WASHER (164-11685-00)	2		
8	2K6-11631-00-97	PISTON (55.97mm STD)	1	U, R	
	2K6-11631-00-98	PISTON (55.98mm STD)	1		
	2K6-11635-00	PISTON (56.25mm 1st O. S)	1		Alternate Parts
	2K6-11636-00	PISTON (56.50mm 2nd O. S)	1		Alternate Parts
	2K6-11637-00	PISTON (56.75mm 3rd O. S)	1		Alternate Parts
	2K6-11638-00	PISTON (57.00mm 4th O. S)	1		Alternate Parts
9	2K6-11601-00	PISTON RING SET (STD)	1s		
	2K6-11601-10	PISTON RING SET (1st O. S)	1s		Alternate Parts
	2K6-11601-20	PISTON RING SET (2nd O. S)	1s		Alternate Parts
	2K6-11601-30	PISTON RING SET (3rd O. S)	1s		Alternate Parts
	2K6-11601-40	PISTON RING SET (4th O. S)	1s		Alternate Parts
10	93310-216A3	BEARING, con-rod small end	1		
11	137-11633-00	PIN, piston	1		
12	93450-17025	CIRCLIP (137-11634-00)	2		
13	93306-20529	BEARING (B6205)	1		
14	93102-25144	OIL SEAL (SD-25-40-8)	1		
15	93306-30406	BEARING (B6304)	1		
16	93103-28100	OIL SEAL (SW-28-40-8)	1		
17	93310-18023	O-RING (1.2-17.6)	1		
18	93387-20488	COLLAR, distance (20-28-18,5)	1		
19	1W1-16111-00	GEAR, primary drive (22T)	1		
20	90282-05905	KEY, straight (353-11546-00)	1		
21	90204-18807	WASHER, spring	1		
22	90179-18344	NUT	1		
23	90280-01017	KEY, woodruff (146-11545-00)	1		

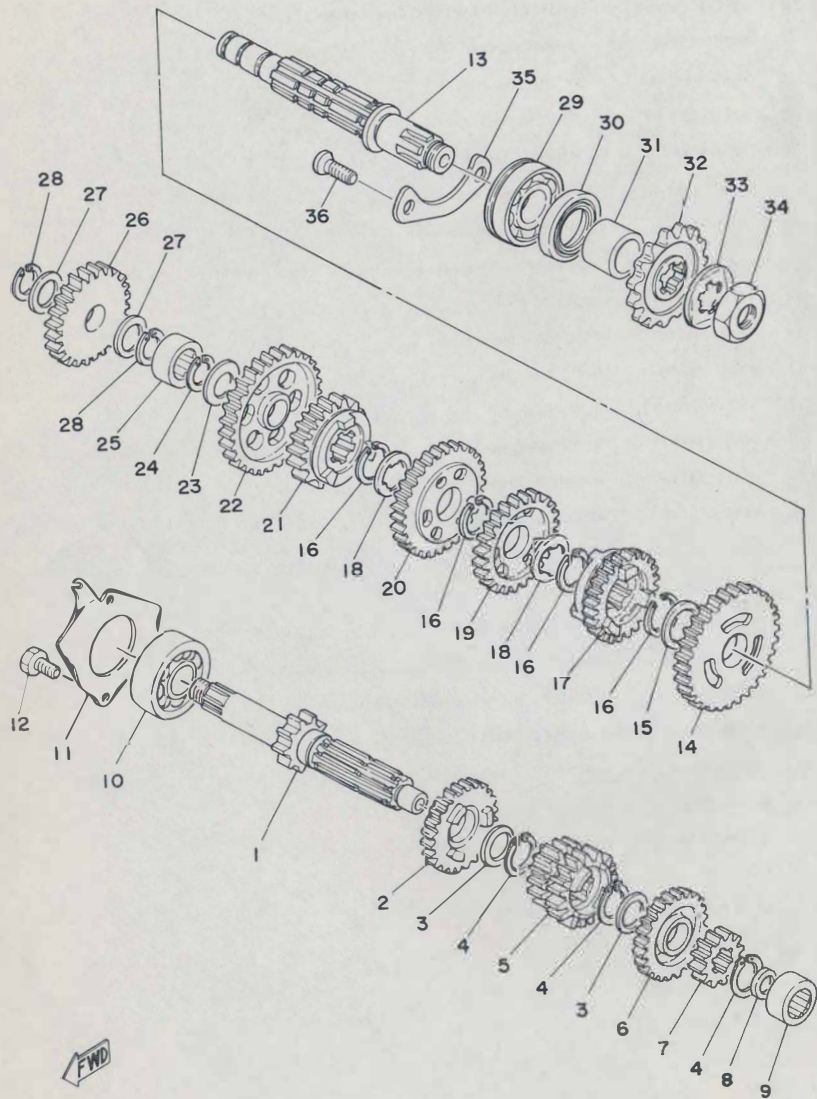
Fig. 4 CLUTCH



Ref. No.	Part No.	Description	Q'ty	Applicable Machine No.	Remarks
4-1	1W1-16301-00	CLUTCH ASS'Y	1		
2	1W1-16150-00	PRIMARY DRIVEN GEAR COMP. (71T)	1		
3	90201-17550	WASHER, plate	1		
4	1G8-16371-00	BOSS, clutch	1		
5	537-16321-00	PLATE, friction	6		
6	137-16325-70	PLATE, clutch 2	5		
7	1W1-16351-00	PLATE, pressure	1		
8	90501-20361	SPRING, compression	5		
9	90159-05011	SCREW, with washer	5		
10	1W1-16358-00	PLATE, push	1		
11	92901-06200	WASHER, plain	1		
12	95301-06600	NUT, hexagon	1		
13	1W1-16356-00	ROD, push 1	1		
14	90170-14171	NUT, hexagon	1		
15	90215-14144	WASHER, lock	1		
16	90560-17147	SPACER	1		
17	90201-17550	WASHER, plate	1		
18	1W1-16357-00	ROD, push 2	1		
19	1W1-16380-00	PUSH LEVER ASS'Y	1		
20	90508-20345	SPRING, torsion	1		
21	90201-14217	WASHER, plate (150-25153-00)	1		
22	93104-14004	OIL SEAL (SO-14-25-5)	1		
23	90149-08108	SCREW	1		
24	90430-08069	GASKET (425-16387-00)	1		
25	93503-16010	BALL (3/16 inch)	1		

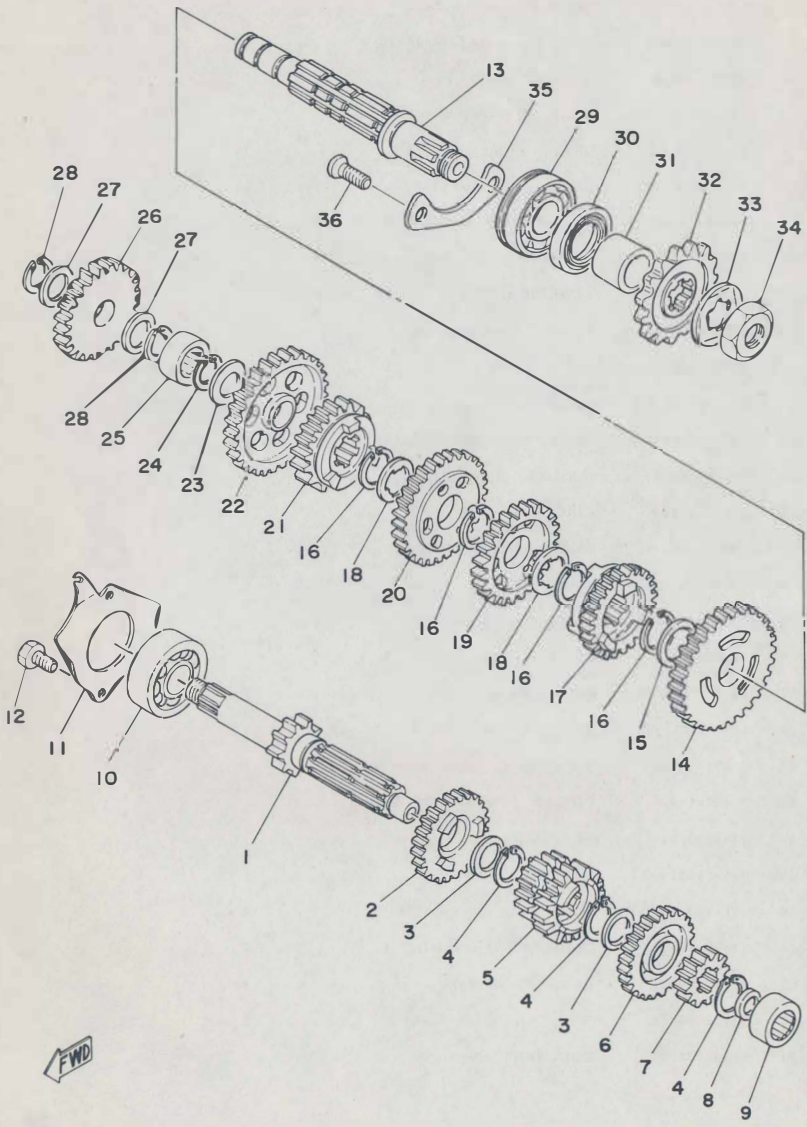
[www.legends-yamaha-enduros.com](http://www.legends-yamaha-enduros.com)

Fig. 5 TRANSMISSION



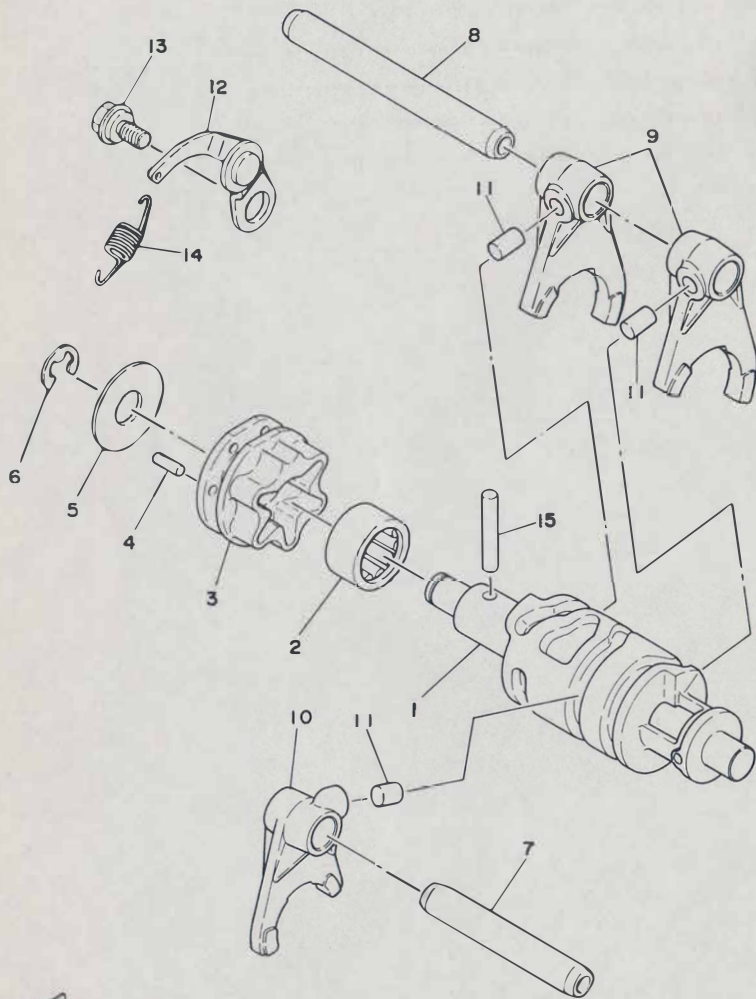
Ref. No.	Part No.	Description	Qty	Applicable Machine No.	Remarks
5-	1	1W1-17411-00	AXLE, main (13T)	1	
2	1W1-17151-00	GEAR, 5th pinion (22T)	1		
3	90201-20266	WASHER, plate (132-17216-00)	2		
4	93410-20038	CIRCLIP (S-20)	3		
5	1W1-17131-01	GEAR, 3rd/4th pinion (18T, 20T)	1		
6	1W1-17161-00	GEAR, 6th pinion (23T)	1		
7	1W1-17121-00	GEAR, 2nd pinion (16T)	1		
8	90201-15563	WASHER, thrust (642-45576-00-10)	1		
9	93311-41530	BEARING	1		
10	93306-30304	BEARING (B6303Z)	1		
11	1W1-17471-01	PLATE, bearing cover	1		
12	97321-06012	BOLT, hexagon	2		
13	1W1-17421-00	AXLE, drive	1		
14	1W1-17221-01	GEAR, 2nd wheel (30T)	1		
15	90201-22555	WASHER, plate	1		
16	93410-22039	CIRCLIP (S-22)	4		
17	1W1-17261-00	GEAR, 6th wheel (23T)	1		
18	90209-18135	WASHER	2		
19	1W1-17241-01	GEAR, 4th wheel (25T)	1		
20	1W1-17231-01	GEAR, 3rd wheel (27T)	1		
21	1W1-17251-00	GEAR, 5th wheel (24T)	1		
22	1W1-17211-01	GEAR, 1st wheel (32T)	1		
23	90201-15563	WASHER, thrust (642-45576-00-10)	1		
24	93440-15012	CIRCLIP (15φ special)	1		
25	93311-31515	BEARING	1		
26	525-15651-00	GEAR, kick idle (25T)	1		
27	137-17417-00-05	SHIM, main axle (15.5-22-0.5)	2		
28	93440-15012	CIRCLIP (15φ special)	2		
29	93306-30411	BEARING (B6304)	1		
30	93102-26042	OIL SEAL (SD-26-38-5)	1		
31	90387-20503	COLLAR (20-26-11.3)	1		

Fig. 5 TRANSMISSION



Ref. No.	Part No.	Description	Qty	Applicable Machine No.	Remarks
5-32	1G8-17461-10	SPROCKET, drive (11T) .....	} U.R 1		STD
	1W1-17461-20	SPROCKET, drive (12T) .....			
	1G8-17461-30	SPROCKET, drive (13T) .....			
33	90215-16127	WASHER, lock .....	1		
34	90179-16226	NUT .....	1		
35	1W1-15381-00	PLATE, bearing cover .....	1		
36	92701-06012	SCREW, flathead .....	2		

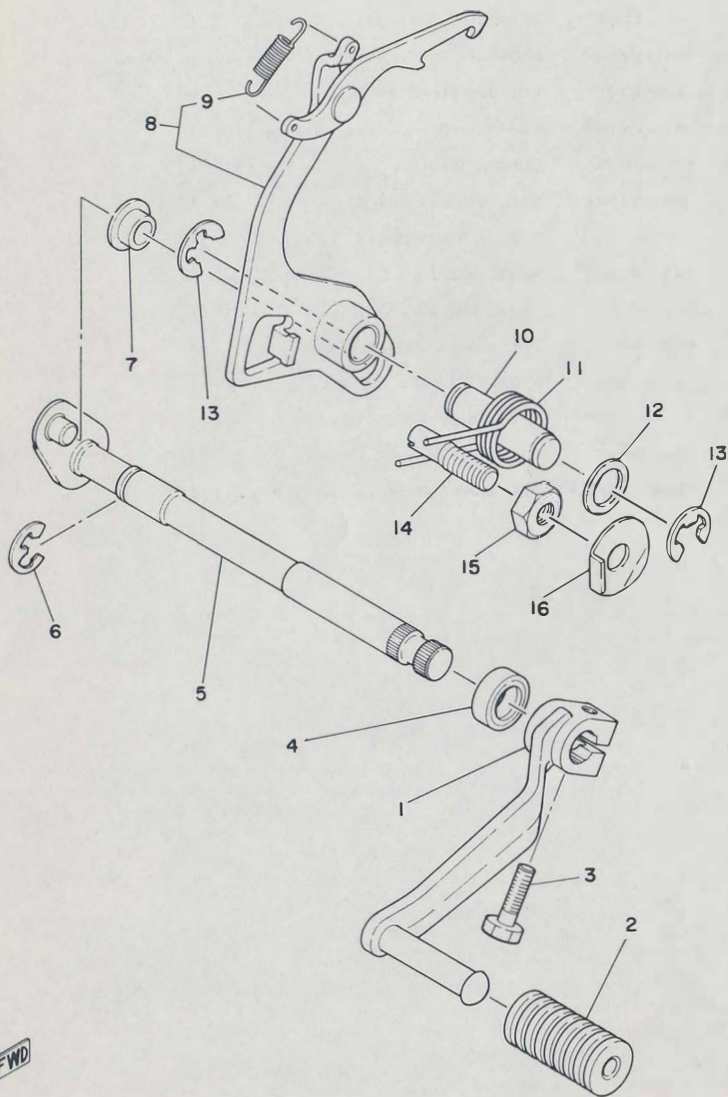
Fig. 6 SHIFTER 1



Ref. No.	Part No.	Description	Q'ty	Applicable Machine No.	Remarks
6-1	1W1-18541-00	CAM, shift	1		
2	93315-21813	BEARING	1		
3	1W1-18185-00	SEGMENT	1		
4	93604-12037	PIN, dowel (4-11.8)	6		
5	1W1-18561-00	PLATE, side	1		
6	93430-08006	CIRCLIP (E-8)	1		
7	1W1-18531-00	BAR, shift fork guide 1	1		
8	1W1-18535-00	BAR, shift fork guide 2	1		
9	1W1-18511-01	FORK, shift 1	2		
10	1W1-18512-01	FORK, shift 2	1		
11	90250-06013	PIN, straight (257-18552-00)	3		
12	1W1-18140-00	STOPPER LEVER ASS'Y	1		
13	1W1-18177-00	BOLT, stopper 2	1		
14	90506-09156	SPRING, tension	1		
15	93604-30018	PIN, dowel (4-29.8)	1		

FWD

Fig. 7 SHIFTER 2

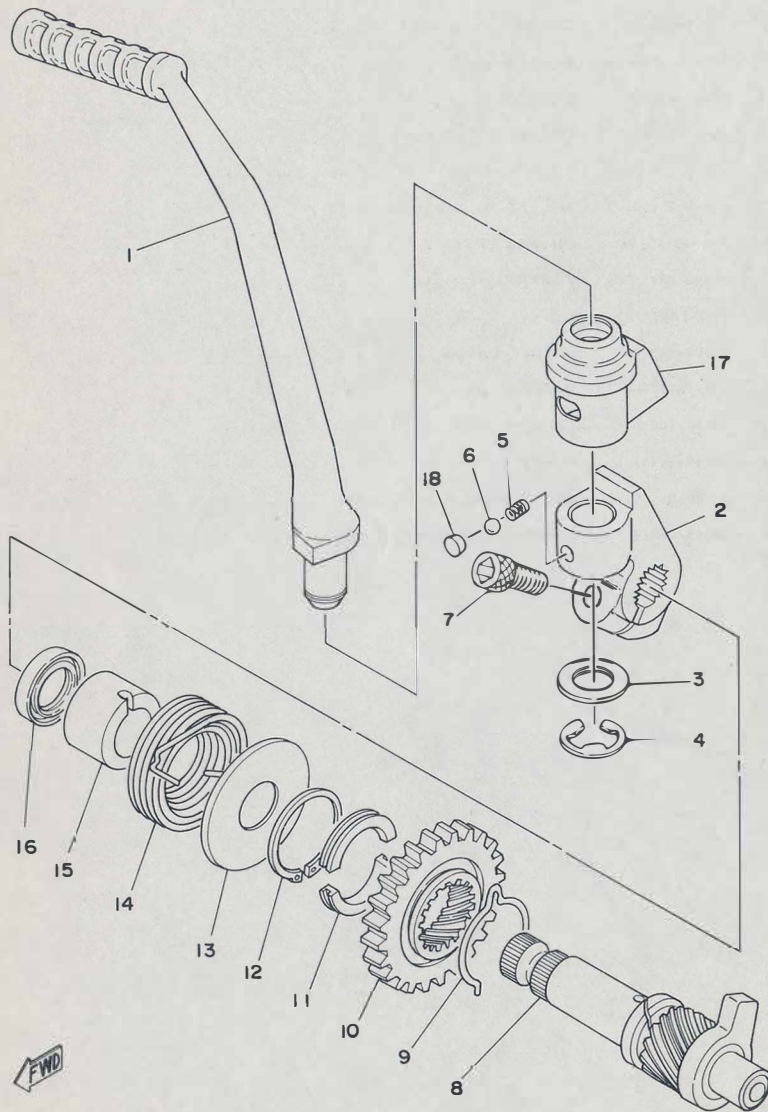


FWD

Ref. No.	Part No.	Description	Q'ty	Applicable Machine No.	Remarks
7-1	1W1-18111-01-33	PEDAL, change	1		Yamaha Black
2	132-18113-01	COVER, change pedal	1		
3	97321-06020	BOLT, hexagon	1		
4	93101-12060	OIL SEAL (S-12-21-4)	1		
5	1W1-18101-02	CHANGE SHAFT ASS'Y	1		
6	93430-10016	CIRCLIP (E-10)	1		
7	401-18178-00	ROLLER, change lever	1		
8	2A6-18120-01	CHANGE LEVER ASS'Y	1		
9	90506-08155	SPRING, tension	1		
10	1W1-18197-01	SHAFT	1		
11	90508-32349	SPRING, torsion	1		
12	102-18137-00-10	WASHER, plate	1		
13	93430-10016	CIRCLIP (E-10)	2		
14	90149-08111	SCREW	1		
15	90170-08029	NUT, hexagon (248-18134-00)	1		
16	90215-08014	WASHER, lock (248-18139-00)	1		

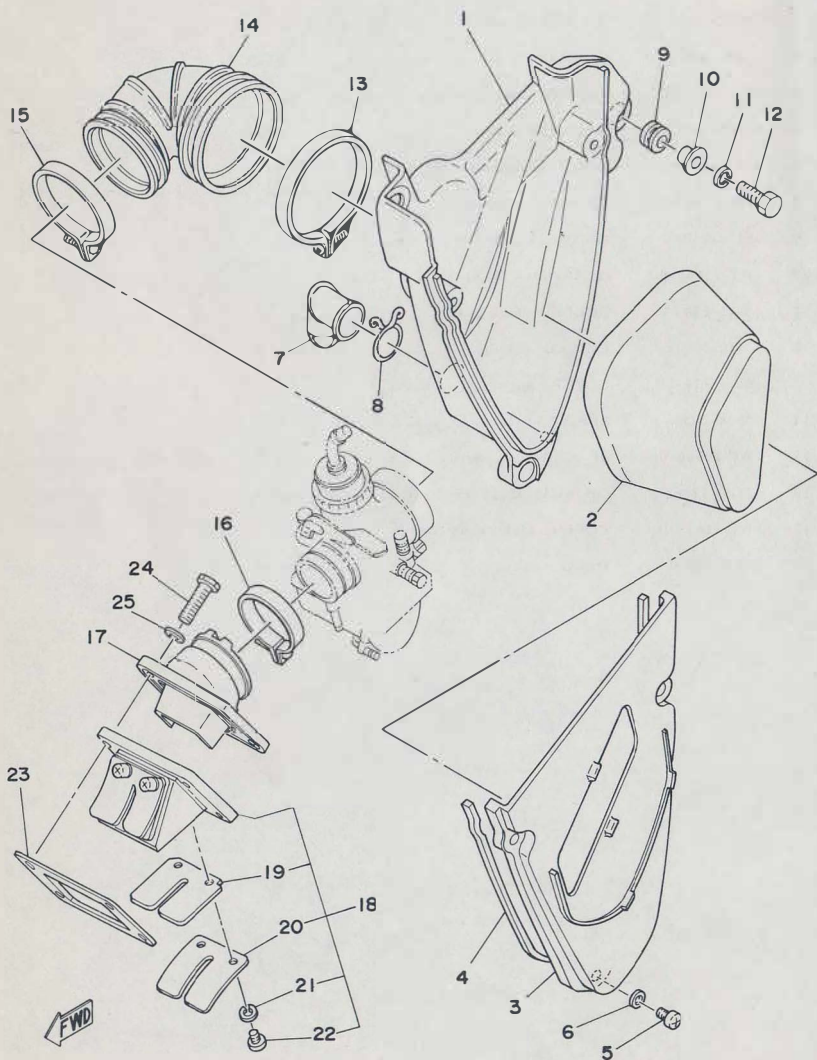
[www.legends-yamaha-enduros.com](http://www.legends-yamaha-enduros.com)

Fig. 8 KICK STARTER



Ref. No.	Part No.	Description	Q'ty	Applicable Machine No.	Remarks
8- 1	1W1-15611-02-33	CRANK, kick	1		Yamaha Black
2	1W1-15621-01	BOSS, kick crank	1		
3	90201-12541	WASHER, plate	1		
4	93430-08007	CIRCLIP (E-8)	1		
5	90501-10459	SPRING, compression	1		
6	93503-16010	BALL (3/16 inch)	1		
7	91316-08025	BOLT, hexagon socket head	1		
8	1W1-15660-00	KICK AXLE ASS'Y	1		
9	90468-26048	CLIP, (315-15687-00)	1		
10	1W1-15641-00	GEAR, kick (27T)	1	Lee Waldie Craig Scott Chris Koira	
11	248-15654-00	HOLDER, kick gear	2		
12	93410-30012	CIRCLIP (S-30)	1		
13	401-15676-00	COVER, spring	1		
14	90508-26346	SPRING, torsion	1		
15	1W1-15666-00	SPACER	1		
16	93101-17062	OIL SEAL (S-17-25-4)	1		
17	1W1-15618-01	COVER, kick crank boss	1		
18	90336-06030	PLUG	1		

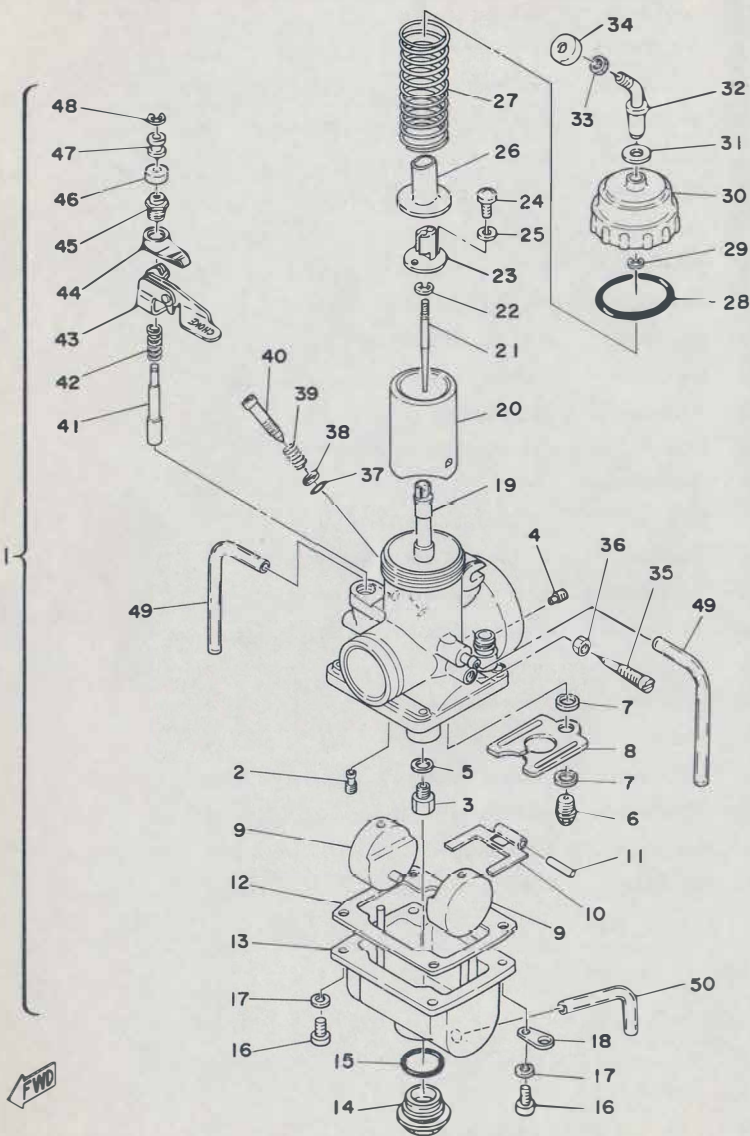
Fig. 9 INTAKE



Ref. No.	Part No.	Description	Q'ty	Applicable Machine No.	Remarks
9-	1	1W1-14411-01	CASE, air cleaner	1	
	2	1W1-14450-02	ELEMENT ASS'Y	1	
	3	1W1-14412-02	CAP, case	1	
	4	1W1-14452-00	SEAL	1	
	5	92501-06025	SCREW, panhead	3	
	6	92901-06600	WASHER, plate	3	
	7	1W1-14457-01	SEAL	1	
	8	90467-20030	CLIP	1	
	9	90480-14102	GROMMET (214-21717-00)	3	
	10	90387-07391	COLLAR (437-21633-00)	3	
	11	92901-06100	WASHER, spring	3	
	12	97301-06025	BOLT, hexagon	3	
	13	90460-77016	CLAMP, hose (360-14456-00)	1	
	14	1W1-14453-00	JOINT	1	
	15	90460-64065	CLAMP, hose (310-14455-00)	1	
	16	90460-49058	CLAMP, hose (278-14455-00)	1	
	17	1W1-13565-00	JOINT, carburetor	1	
	18	1L8-13610-00	REED VALVE ASS'Y	1	
	19	1L8-13613-00	REED, valve	2	
	20	311-13616-01	STOPPER, reed valve	2	
	21	92901-03100	WASHER, spring	4	
	22	98512-03008	SCREW, panhead	4	
	23	311-13621-01	PACKING, valve seat	1	
	24	97301-06025	BOLT, hexagon	4	
	25	92901-06600	WASHER, plate	4	



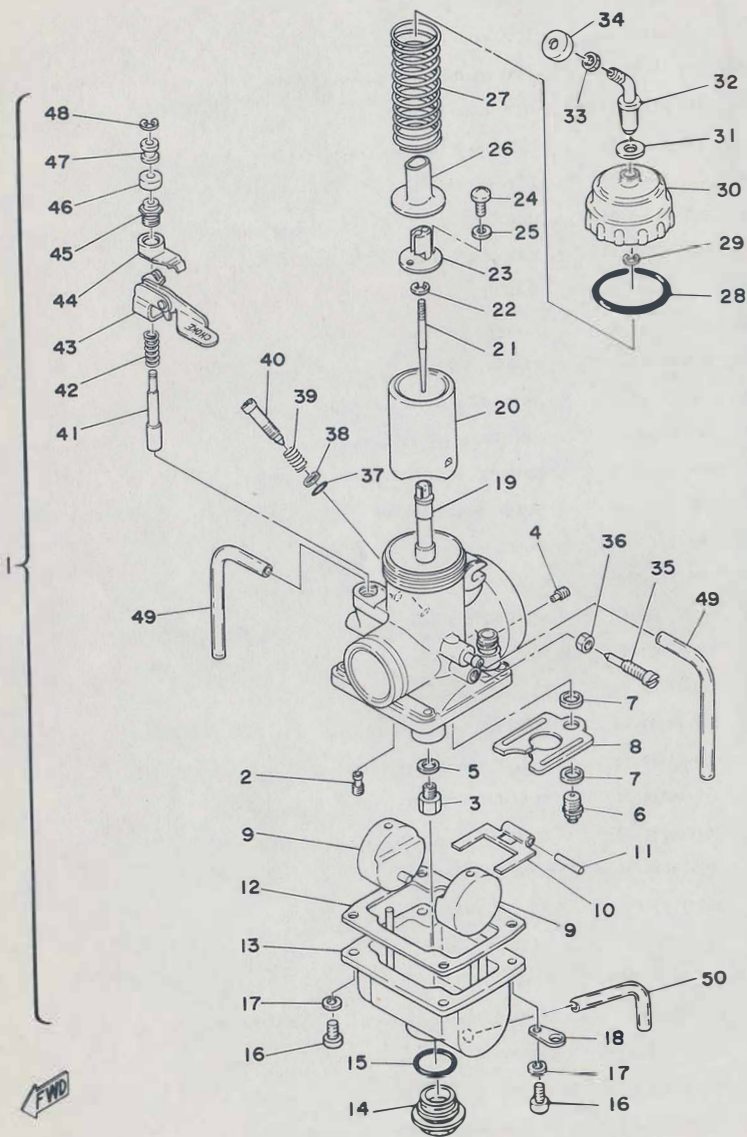
Fig. 10 CARBURETOR



Ref. No.	Part No.	Description	Qty	Applicable Machine No.	Remarks
10-	1	2K6-14101-00	CARBURETOR ASS'Y	1	
2	193-14142-60	JET, pilot (#60)	1		
3	137-14143-54	JET, main (#270)	1	U. R	STD
	137-14143-56	JET, main (#280)			
	137-14143-58	JET, main (#290)			
4	239-14172-20	JET, air (#2.0)	1		
5	537-14153-00	RING	1		
6	239-14190-33	VALVE SEAT ASS'Y (#3.3)	1		
7	239-14195-00	WASHER, valve seat	2		
8	483-14146-00	PLATE	1		
9	310-14185-00	FLOAT	2		
10	310-14187-00	ARM, float	1		
11	127-14186-00	PIN, float	1		
12	483-14184-00	GASKET, float chamber	1		
13	2K6-14181-16	BODY, float chamber	1		
14	2K6-14115-00	PLUG, screw	1		
15	2K6-14147-00	O-RING	1		
16	98501-05016	SCREW, panhead	4		
17	92901-05100	WASHER, spring	4		
18	313-14146-00	PLATE	2		
19	239-14141-48	NOZZLE, main (P-8)	1		
20	509-14112-30	VALVE, throttle (#3.0)	1		
21	239-14116-22	NEEDLE (6F22-3)	1		
22	164-14137-00	CLIP	1		
23	509-14274-00	CONNECTOR	1		
24	98501-03008	SCREW, panhead	2		
25	92901-03100	WASHER, spring	2		
26	509-14136-00	SEAT	1		
27	363-14131-00	SPRING, throttle valve	1		
28	93210-40289	O-RING (2-40)	1		
29	363-14137-00	CLIP	1		
30	500-14158-00	TOP, mixing chamber	1		

FWD

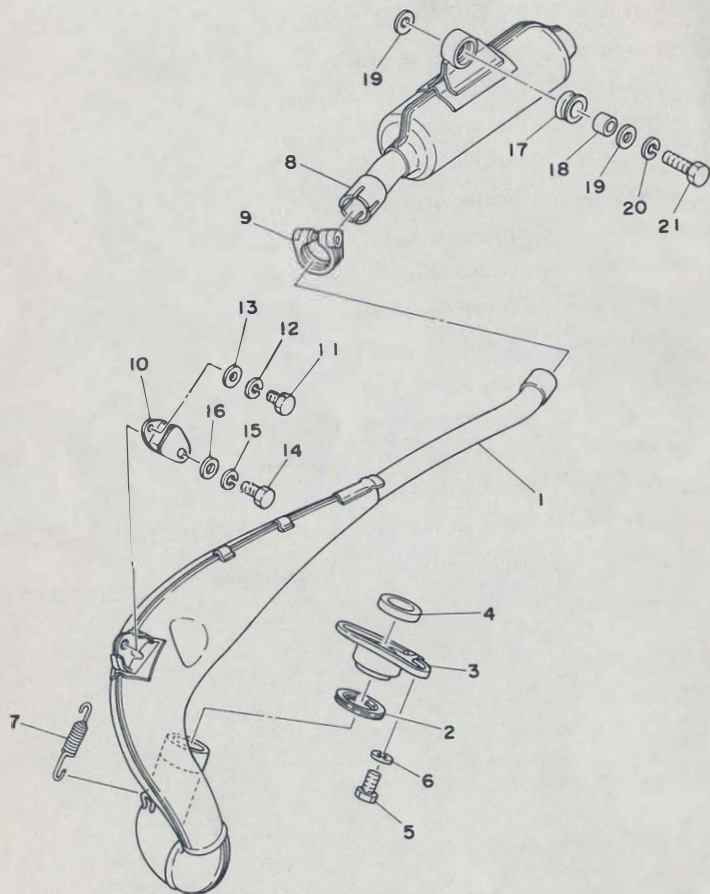
Fig. 10 CARBURETOR



Ref. No.	Part No.	Description	Q'ty	Applicable Machine No.	Remarks
10-31	509-14198-00	GASKET	1		
32	500-14155-00	HOLDER, guide	1		
33	127-14161-00	NUT, wire adjusting	1		
34	1M1-14169-00	CAP	1		
35	204-14122-00	SCREW, throttle	1		
36	802-14161-00	NUT, wire adjusting	1		
37	812-14147-00	O-RING	1		
38	812-14235-00	WASHER	1		
39	137-14134-00	SPRING, air adjusting	1		
40	1G8-14123-00	SCREW, air adjusting	1		
41	1W1-14171-00	PLUNGER, starter	1		
42	256-14135-00	SPRING, plunger	1		
43	1W1-14175-01	LEVER, starter left	1		
44	275-14178-00	PLATE, spring	1		
45	802-14174-00	CAP, plunger	1		
46	802-14173-00	COVER, plunger cap	1		
47	583-14918-00	RING, plunger	1		
48	737-14137-00	CLIP, plunger	1		
49	310-14197-00	PIPE, air vent	2		
50	493-14196-00	PIPE, over flow	1		

[www.legends-yamaha-enduros.com](http://www.legends-yamaha-enduros.com)

Fig. 11 EXHAUST

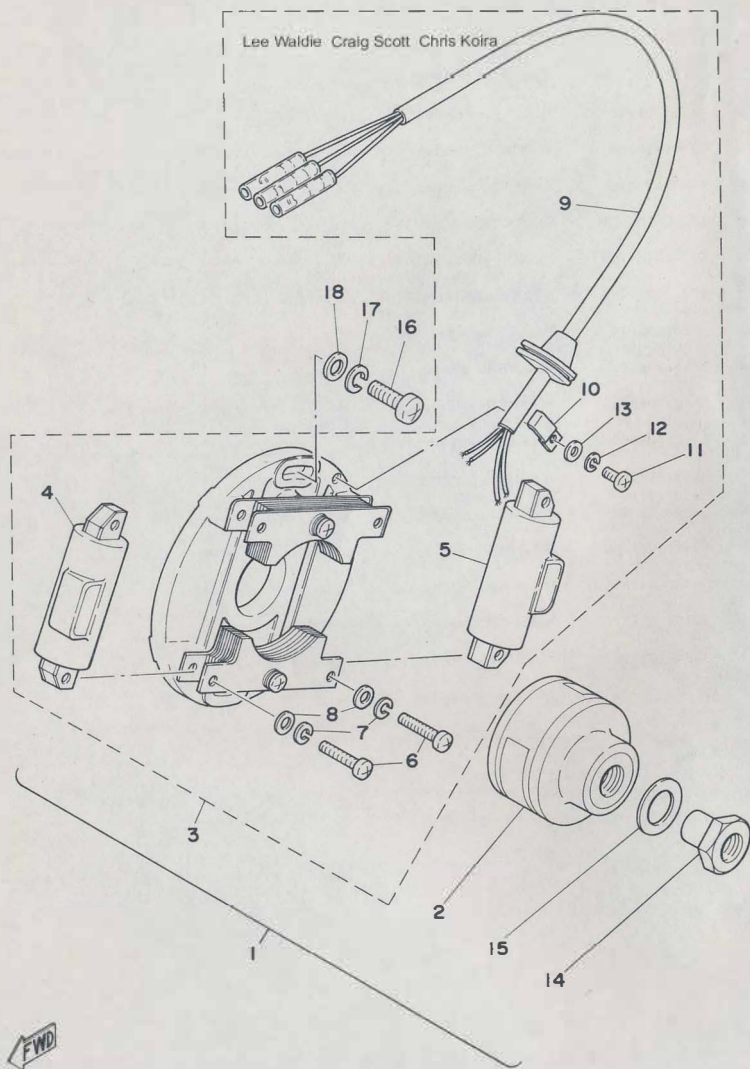


Ref. No.	Part No.	Description	Q'ty	Applicable Machine No.	Remarks
11- 1	2K6-14610-00	EXHAUST PIPE ASS'Y	1		
2	248-14623-00	GASKET	1		
3	2K5-14612-00	NUT, ring	1		
4	152-14613-00	GASKET, exhaust pipe	1		
5	97301-06016	BOLT, hexagon	2		
6	92901-06100	WASHER, spring	2		
7	90507-20030	SPRING, tension	1		
8	1W1-14753-01	SILENCER	1		
9	537-14788-00	BAND, silencer	1		
10	483-14781-00	STAY, muffler	1		
11	97301-06016	BOLT, hexagon	1		
12	92901-06100	WASHER, spring	1		
13	92901-06600	WASHER, plate	1		
14	97301-08020	BOLT, hexagon	1		
15	92901-08100	WASHER, spring	1		
16	92901-08600	WASHER, plate	1		
17	565-14747-00	DAMPER	1		
18	90387-08258	COLLAR	1		
19	90201-08113	WASHER, plate (611-48556-30)	2		
20	92901-08100	WASHER, spring	1		
21	97301-08030	BOLT, hexagon	1		

FWD

[www.legends-yamaha-enduros.com](http://www.legends-yamaha-enduros.com)

Fig. 12 C. D. I. MAGNETO

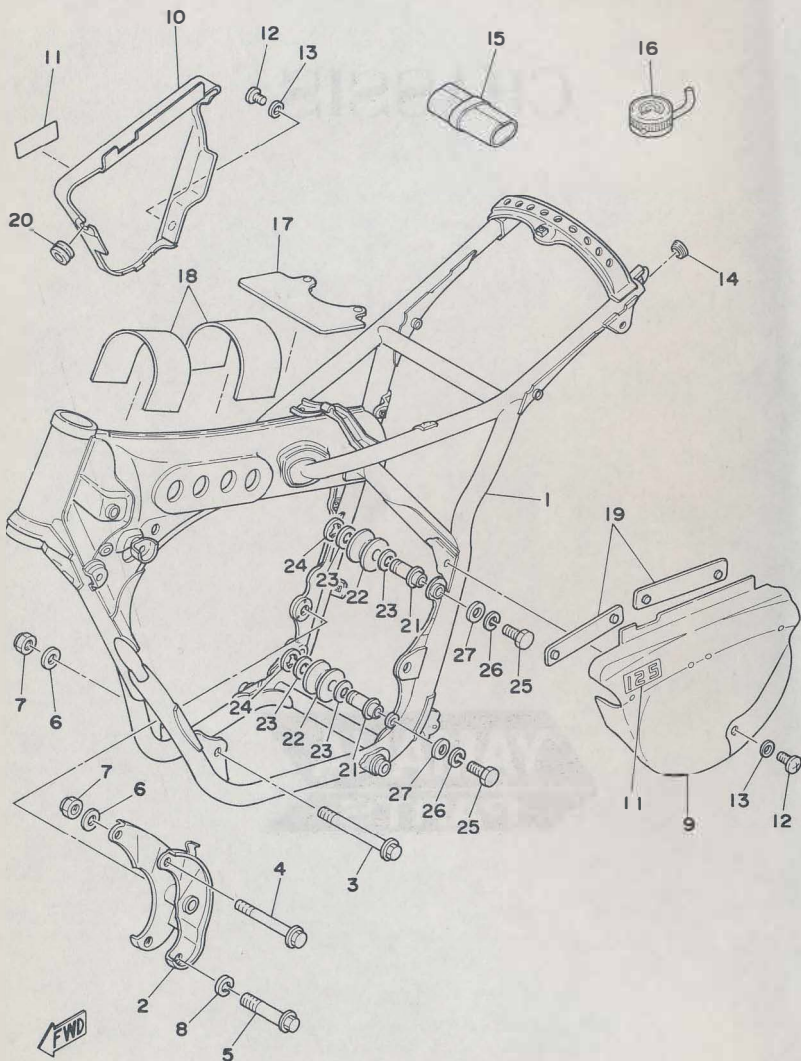


Ref. No.	Part No.	Description	Qty	Applicable Machine No.	Remarks
12- 1	1G8-85500-10	C. D. I. MAGNETO ASS'Y	1		
2	1G8-85550-10	ROTOR ASS'Y	1		
3	565-85510-10	STATOR ASS'Y	1		
4	565-85566-10	COIL, charge 1	1		
5	565-85567-10	COIL, charge 2	1		
6	98501-05025	SCREW, panhead	4		
7	92901-05100	WASHER, spring	4		
8	92901-05600	WASHER, plate	4		
9	565-85515-10	LEAD WIRE ASS'Y	1		
10	109-81328-11	CLAMP, lead wire	1		
11	98501-04008	SCREW, panhead	1		
12	92901-04100	WASHER, spring	1		
13	92901-04600	WASHER, plate	1		
14	322-85553-10	NUT, rotor	1		
15	322-85554-10	WASHER, rotor	1		
16	92501-06020	SCREW, panhead	2		
17	92901-06100	WASHER, spring	2		
18	90201-06045	WASHER, plate	2		

# CHASSIS

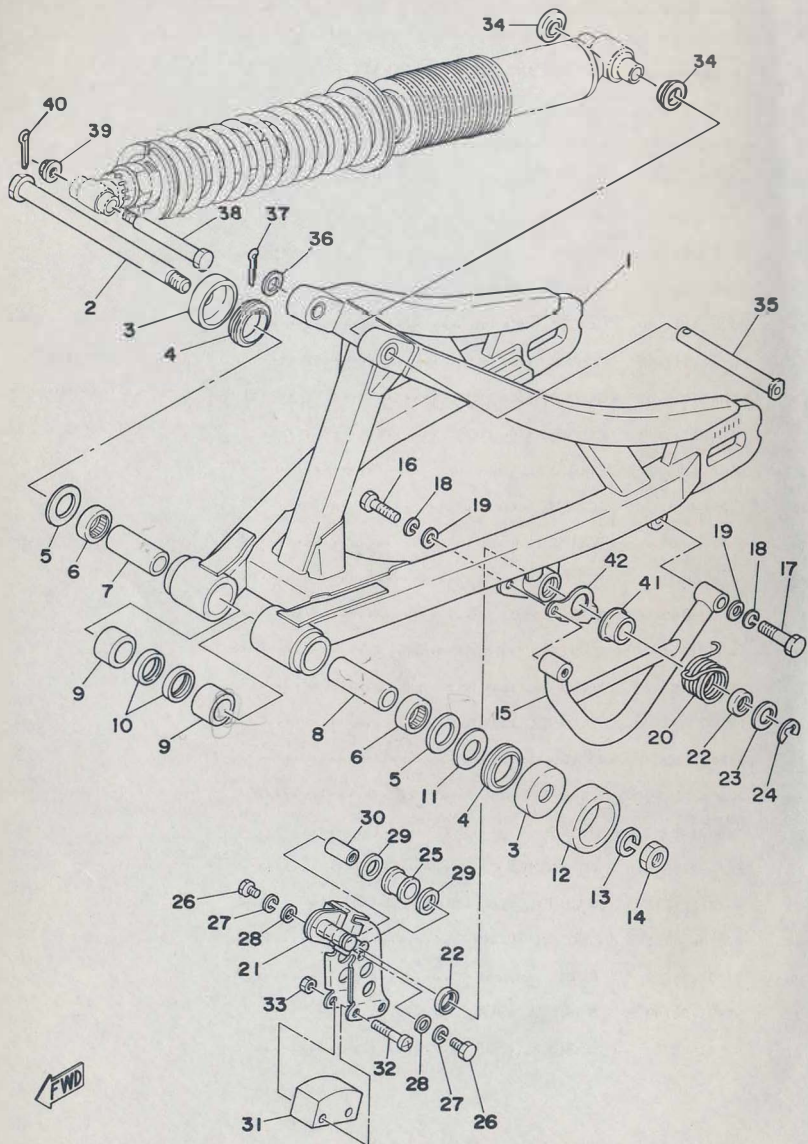


Fig. 13 FRAME · SIDE COVER



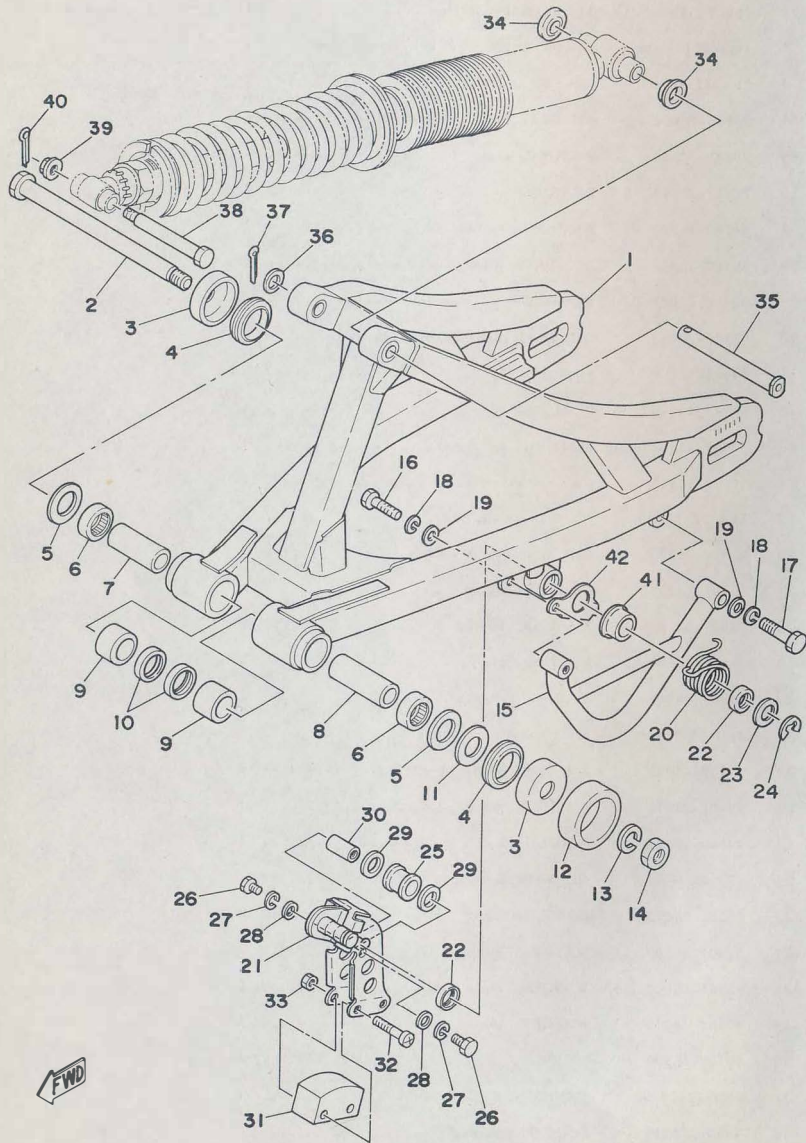
Ref. No.	Part No.	Description	Q'ty	Applicable Machine No.	Remarks
13- 1	2K6-21110-01-33	FRAME COMP.	1		Yamaha Black
2	1W1-21410-00	ENGINE BRACKET COMP.	1		
3	90105-08099	BOLT	1		
4	90105-08100	BOLT	1		
5	90105-10037	BOLT	1		
6	92901-08200	WASHER, plain	2		
7	90185-08054	NUT, U	2		
8	92901-10100	WASHER, spring	1		
9	1W1-21711-00	COVER, side left	1		Competition Yellow
	1W1-21711-10	COVER, side left	1		Clean White
10	1W1-21721-02	COVER, side right	1		Competition Yellow
	1W1-21721-11	COVER, side right	1		Clean White
11	1K6-14729-00	EMBLEM, protector	2		
12	91901-06012	SCREW, bind	2		
13	90201-06067	WASHER, plate	2		
14	90339-13005	PLUG	2		
15	1W1-28100-10	TOOL ASS'Y	1		
16	1W1-2811A-00	GAUGE, fork air chamber	1		
17	1W1-24181-00	DAMPER, tank locating 1	1		
18	1W1-24183-00	DAMPER, tank locating 3	2		
19	537-21732-00	SEAL, side cover	2		
20	90480-12053	DAMPER, side cover	1		
21	2K6-2148A-01	SHAFT	2		
22	2K6-22178-00	TENSIONER	2		
23	90201-13202	WASHER, plate (201-15653-00)	4		
24	93430-10015	CIRCLIP (E-10)	2		
25	97301-08020	BOLT, hexagon	2		
26	92901-08100	WASHER, spring	2		
27	92901-08200	WASHER, plain	2		

Fig. 14 REAR ARM



Ref. No.	Part No.	Description	Q'ty	Applicable Machine No.	Remarks
14- 1	2K6-22110-00-33	REAR ARM COMP.	1		Yamaha Black
2	1W1-22141-00	SHAFT, pivot	1		
3	2K6-22128-00	COVER, thrust	2		
4	93108-35004	OIL SEAL (OSO-35-41.5-8)	2		
5	90201-22680	WASHER, plate	2		
6	93317-22214	BEARING	2		
7	90380-16063	BUSHING, solid	1		
8	90380-16056	BUSHING, solid	1		
9	90386-22097	BUSHING	2		
10	93109-22019	OIL SEAL (SDO-20.9-28-4)	2		
11	240-22127-00	SHIM	U.N		
12	431-22151-03	SEAL, guard	1		
13	92901-16100	WASHER, spring	1		
14	90170-16111	NUT, hexagon	1		
15	2K8-22153-00	GUARD, chain	1		
16	97301-08030	BOLT, hexagon	1		
17	97301-08035	BOLT, hexagon	1		
18	92901-08100	WASHER, spring	2		
19	92901-08600	WASHER, plate	2		
20	90508-35365	SPRING, torsion	1		
21	2K8-22179-00	ARM, chain tensioner	1		
22	93109-14021	OIL SEAL (SDO-14-20-3.2)	2		
23	90201-14411	WASHER, plate	1		
24	93430-10015	CIRCLIP (E-10)	1		
25	1W1-22178-00	TENSIONER	1		
26	97301-06012	BOLT, hexagon	2		
27	92901-06100	WASHER, spring	2		
28	92901-06600	WASHER, plate	2		
29	90201-14411	WASHER, plate	2		
30	90179-06239	NUT	1		
31	2N0-22178-00	TENSIONER	1		
32	98501-05035	SCREW, panhead	2		

Fig. 14 REAR ARM

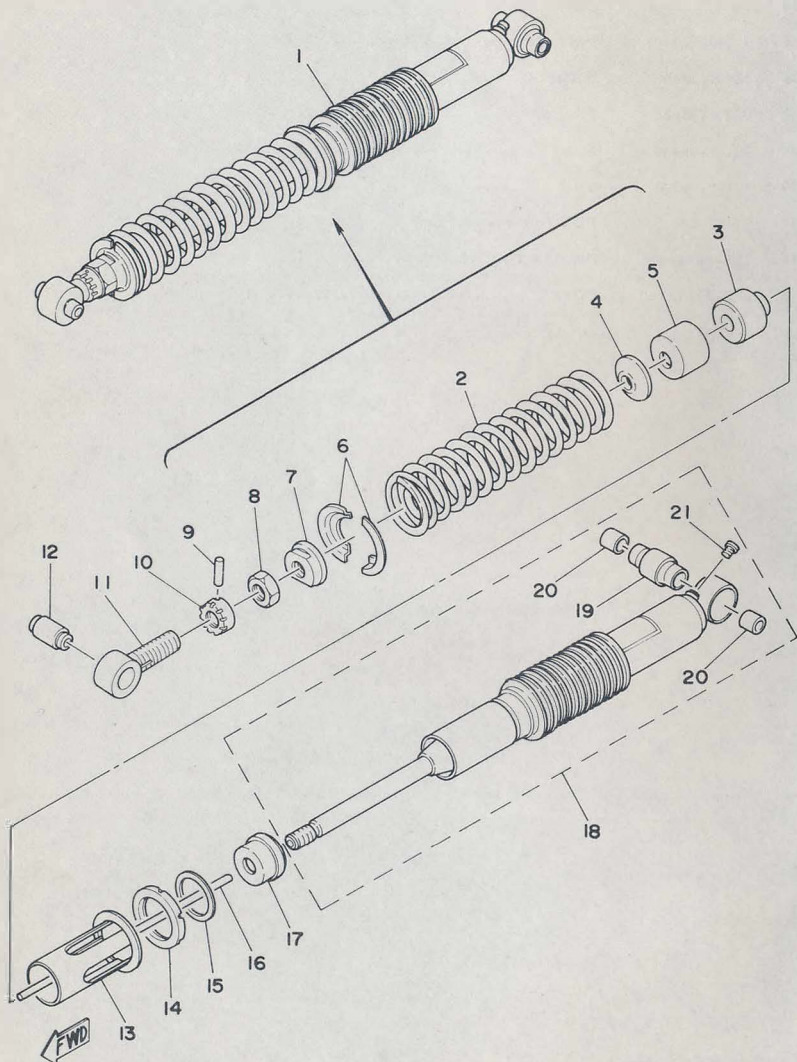


Ref. No.	Part No.	Description	Q'ty	Applicable Machine No.	Remarks
14-33	95301-05700	NUT, hexagon	2		
34	1W1-22128-00	COVER, thrust	2		
35	90240-12060	PIN, with hole	1		
36	92901-12600	WASHER, plate	1		
37	91401-30022	PIN, cotter	1		
38	90109-08480	BOLT	1		
39	90179-08243	NUT	1		
40	91401-20015	PIN, cotter	1		
41	2K8-22147-00	PROTECTOR, chain	1		
42	2K8-2219X-00	COVER	1		

[www.legends-yamaha-enduros.com](http://www.legends-yamaha-enduros.com)



Fig. 15 REAR CUSHION (Except IRAN)

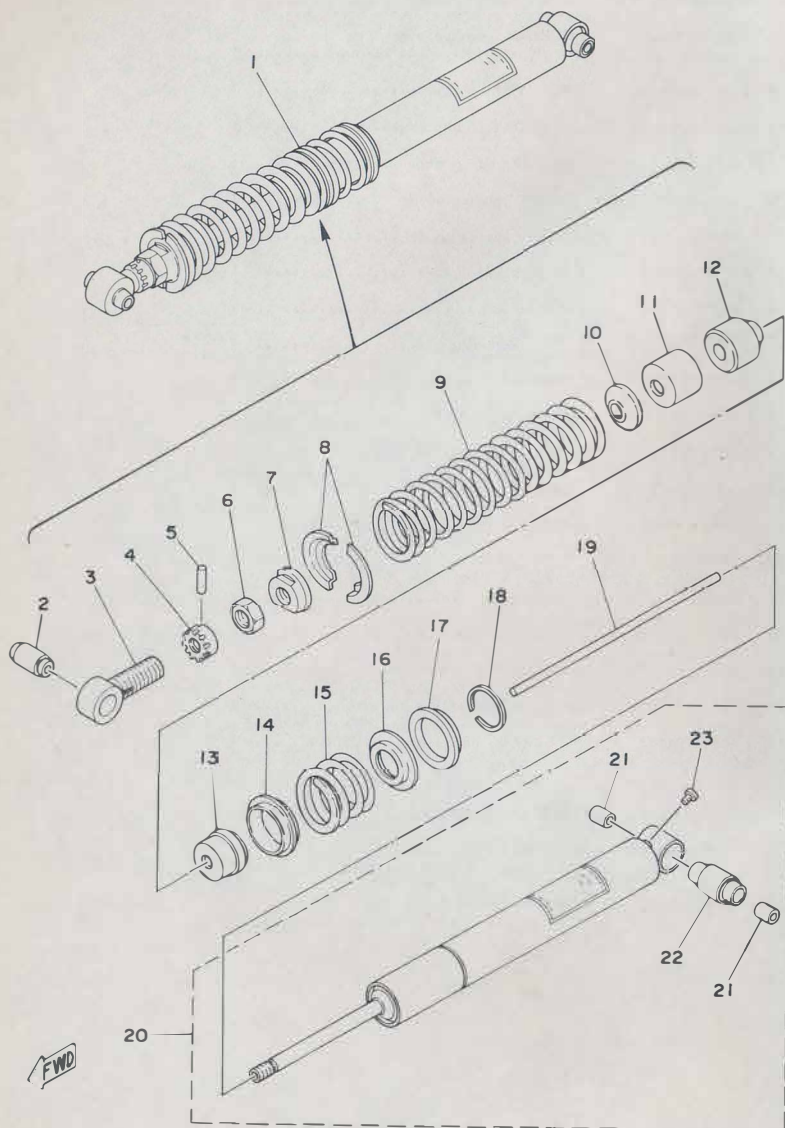


Ref. No.	Part No.	Description	Q'ty	Applicable Machine No.	Remarks
15- 1	2K6-22210-00	REAR CUSHION ASS'Y .....	1		
	2	SPRING, compression (K <sub>1</sub> =2.31 K <sub>2</sub> =4.01 kg/mm) .....	1		
	3	STOPPER, bump .....	1		
	4	SUPPORT, bump stop .....	1		
	5	COVER, bump stop .....	1		
	6	GUIDE, spring upper .....	2		
	7	SEAT, spring upper .....	1		
	8	NUT, hexagon .....	1		
	9	PIN, dowel .....	1		
	10	NUT, adjusting .....	1		
	11	BRACKET, upper .....	1		
	12	BUSHING, upper bracket .....	1		
	13	GUIDE, spring 2 .....	1		
	14	SEAT, spring under .....	1		
	15	CIRCLIP (50¢ special) .....	1		
	16	ROD, push .....	1		
	17	CAP, case .....	1		
	18	DAMPER SUB ASS'Y .....	1		
	19	BUSHING, lower .....	1		
	20	BUSHING, solid .....	2		
	21	SCREW, panhead .....	1		

ALTERNATE PARTS

2	90501-98478	SPRING, compression (K <sub>1</sub> =1.91 K <sub>2</sub> =4.02 kg/mm) .....	1		Soft (Painted Yellow)
	90501-98477	SPRING, compression (K <sub>1</sub> =2.71 K <sub>2</sub> =4.03 kg/mm) .....	1		Hard (Painted Red)

Fig.16 REAR CUSHION (Exclusive for IRAN)

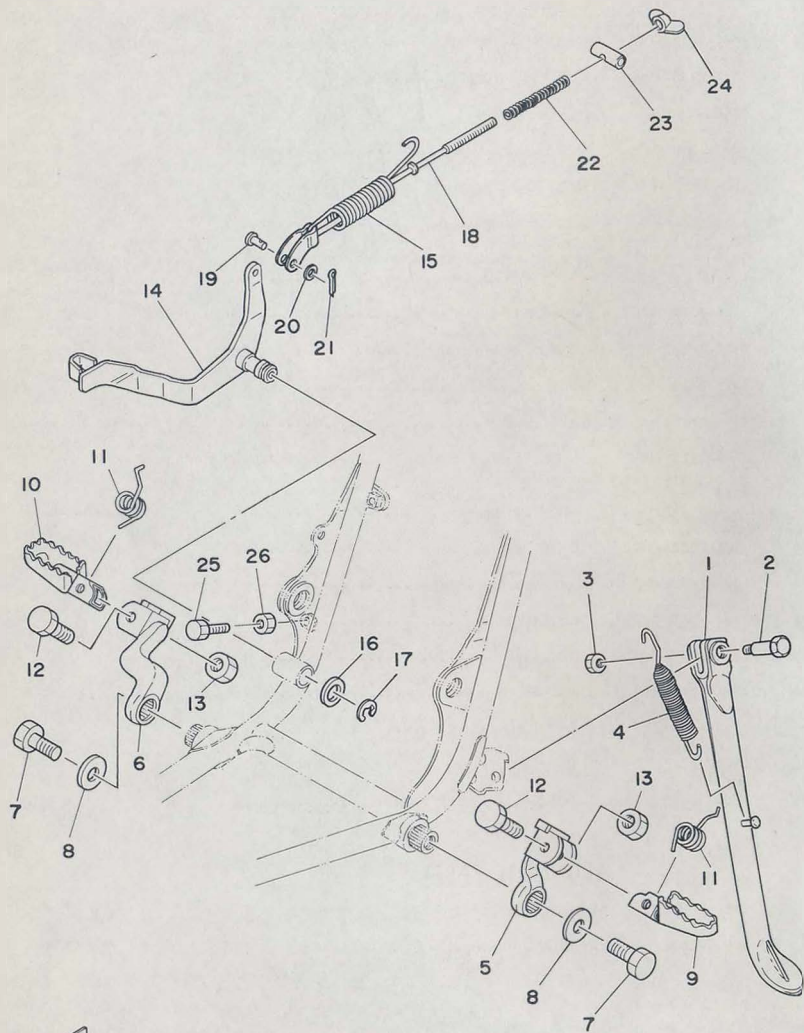


Ref. No.	Part No.	Description	Q'ty	Applicable Machine No.	Remarks
16- 1	1W2-22210-01	REAR CUSHION ASS'Y	1		
2	1W1-22216-00	BUSHING, upper bracket	1		
3	1W1-22219-00	BRACKET, upper	1		
4	1W1-22497-00	NUT, adjusting	1		
5	93604-26132	PIN, dowel	1		
6	90170-20213	NUT, hexagon	1		
7	2K6-22213-00	SEAT, spring upper	1		
8	2K6-22214-00	GUIDE, spring upper	2		
9	90501-99471	SPRING, compression (K=5.20 kg/mm)	1		STD (Painted Pink)
10	1W1-22228-00	SUPPORT, bump stop	1		
11	1W1-22221-00	COVER, bump stop	1		
12	1W1-22493-00	BUMPER, stop	1		
13	1W1-22472-00	CAP, case	1	Lee Waldie Craig Scott Chris Kpira	
14	1W2-22234-00	GUIDE, spring middle	1		
15	90501-85470	SPRING, compression (K=7.41 kg/mm)	1		Painted Blue
16	1W2-22224-00	GUIDE, spring lower	1		
17	1W1-22223-00	SEAT, spring under	1		
18	93440-50058	CIRCLIP	1		
19	2K6-22489-00	ROD, push	1		
20	1W2-22401-01	DAMPER SUB ASS'Y	1		
21	90380-12051	BUSHING, solid	2		
22	1W1-22226-00	BUSHING, lower	1		
23	98501-04005	SCREW, panhead	1		

ALTERNATE PARTS

9	90501-80483	SPRING, compression (K=5.96 kg/mm)	1		Soft (Painted Yellow)
	90501-90482	SPRING, compression (K=9.10 kg/mm)	1		Hard (Painted Red)

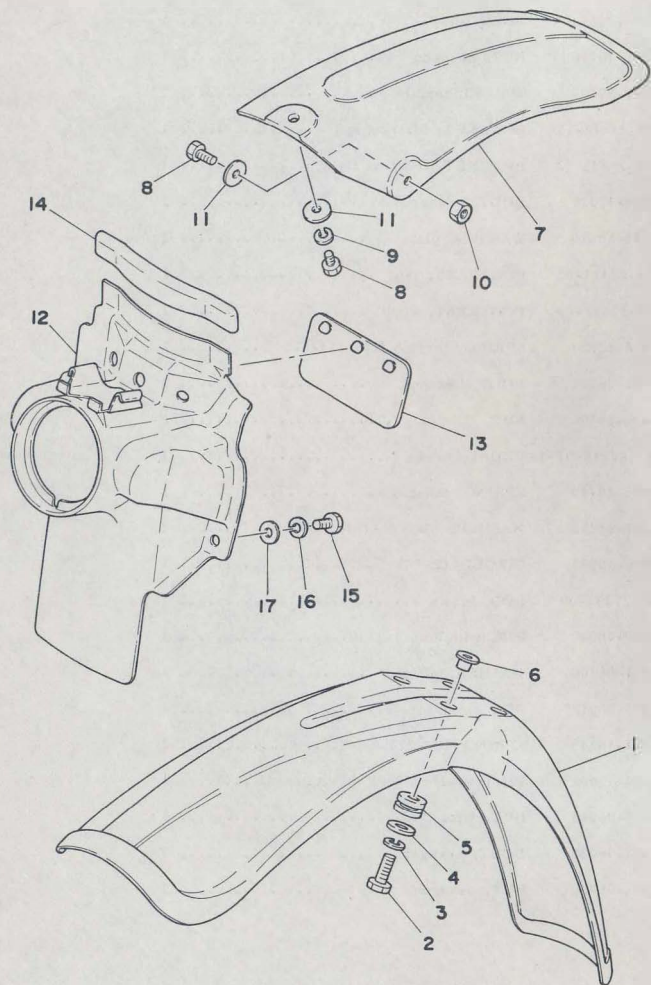
Fig. 17 STAND · FOOTREST · BRAKE PEDAL



Ref. No.	Part No.	Description	Qty	Applicable Machine No.	Remarks
17- 1	2K6-27311-00	STAND, side .....	1		
	1W2-27311-01	STAND, side .....	1		Exclusive for Iran
2	90109-10473	BOLT .....	1		
3	95301-10700	NUT, hexagon .....	1		
4	90507-29008	SPRING, tension .....	1		
5	1W1-27412-10	BRACKET, footrest left .....	1		
6	1W1-27422-12	BRACKET, footrest right .....	1		
7	97311-10016	BOLT, hexagon .....	2		
8	90201-10639	WASHER, plate .....	2		
9	1W4-27411-00	FOOTREST, left .....	1		
10	1W4-27421-00	FOOTREST, right .....	1		
11	90508-20023	SPRING, torsion (214-27426-00) .....	2		
12	90101-08371	BOLT, hexagon .....	2		
13	95601-08100	NUT, U .....	2		
14	1W1-27211-01-33	PEDAL, brake .....	1		Yamaha Black
15	90506-20140	SPRING, tension .....	1		
16	90201-14212	WASHER, plate (611-44126-00) .....	1		
17	93430-10015	CIRCLIP (E-10) .....	1		
18	2K6-27231-00	ROD, brake .....	1		
19	90240-06040	PIN, with hole .....	1		
20	92901-06200	WASHER, plain .....	1		
21	91401-20012	PIN, cotter .....	1		
22	90501-10245	SPRING (180-27236-00) .....	1		
23	90249-12008	PIN (156-27237-00) .....	1		
24	90175-06013	NUT, wing .....	1		
25	97301-06020	BOLT, hexagon .....	1		
26	95301-06700	NUT, hexagon .....	1		

FWD

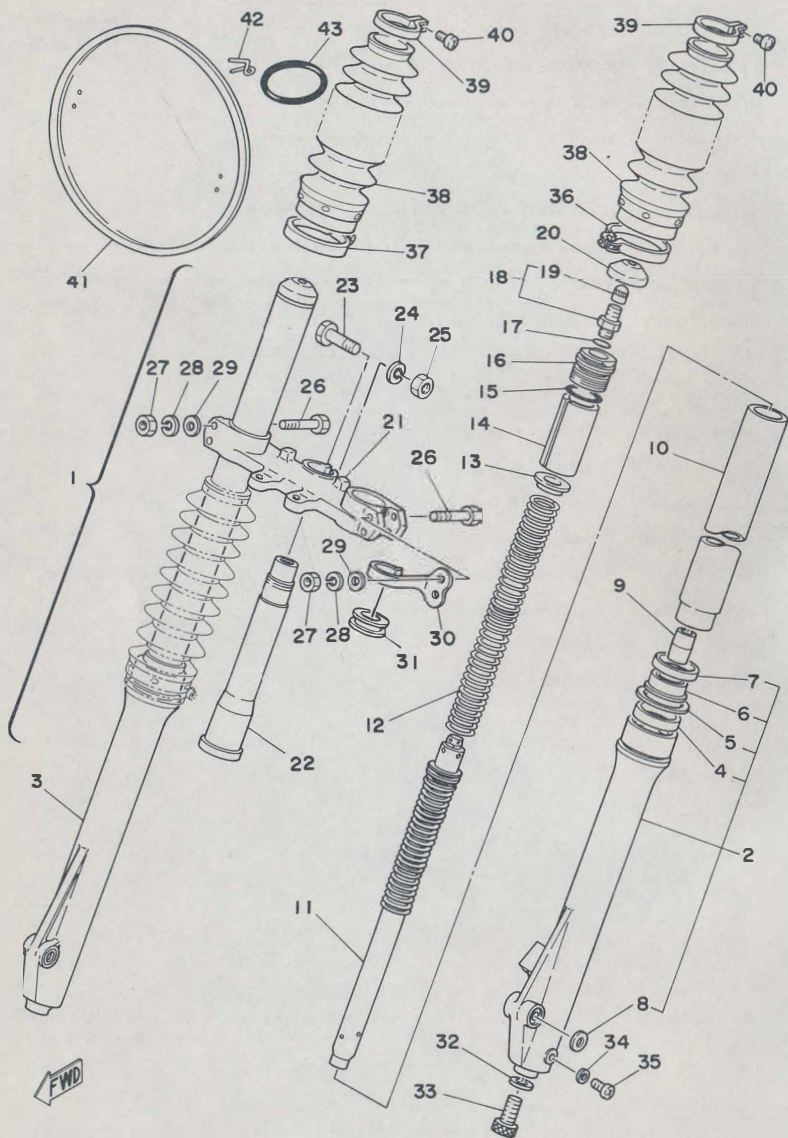
Fig. 18 FRONT FENDER · REAR FENDER



Ref. No.	Part No.	Description	Q'ty	Applicable Machine No.	Remarks
18- 1	1W1-21511-00	FENDER, front	1		Competition Yellow
	1W1-21511-10	FENDER, front	1		Clean White
2	97301-06025	BOLT, hexagon	4		
3	92901-06100	WASHER, spring	4		
4	90201-06067	WASHER, plate	4		
5	90480-14198	GROMMET	4		
6	90387-06388	COLLAR (322-21544-00)	4		
7	2K6-21611-00	FENDER, rear	1		Competition Yellow
	2K6-21611-10	FENDER, rear	1		Clean White
8	97301-06014	BOLT, hexagon	3		
9	92901-06100	WASHER, spring	1		
10	95601-06100	NUT, U	2		
11	90201-06067	WASHER, plate	3		
12	1W1-21620-01	MUD GUARD COMP.	1		
13	1M1-21621-00	FLAP	1		
14	565-21746-00	SEAL, mud guard	1		
15	97301-06014	BOLT, hexagon	2		
16	92901-06100	WASHER, spring	2		
17	90201-06067	WASHER, plate	2		

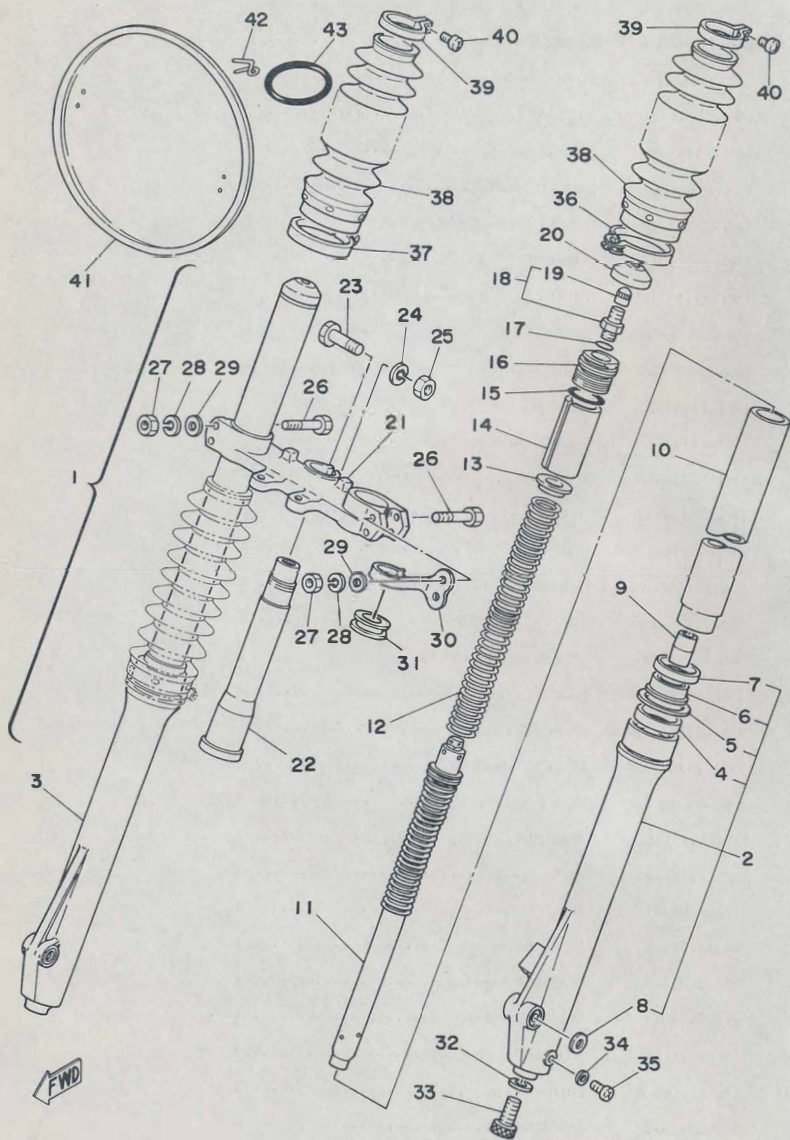


Fig. 19 FRONT FORK (Except IRAN)



Ref. No.	Part No.	Description	Q'ty	Applicable Machine No.	Remarks
19- 1	2K6-23101-L0	FRONT FORK ASS'Y	1		
2	2K6-23126-L0	TUBE, outer left	1		
3	2K6-23136-L0	TUBE, outer right	1		
4	1W1-23145-L0	OIL SEAL	2		
5	1W1-23156-L0	RING, snap	2		
6	1G8-23144-L1	SEAL, dust	2		
7	1W1-23148-L0	DUST SEAL CASE, outer tube	2		
8	1W1-23168-L0	WASHER	2		
9	1W1-23173-L0	SPINDLE	2	Lee Waldie Craig Scott Chris Koiran	
10	2K6-23110-L0	INNER TUBE COMP.	2		
11	2K6-23170-L0	CYLINDER COMP., front fork	2		
12	1W1-23141-L0	SPRING, front fork (K=0.255 kg/mm)	2		
13	1W1-23142-L0	GUIDE, fork spring	2		
14	1W1-23118-L0	SPACER	2		
15	1W1-23114-L0	O-RING	2		
16	1W1-23111-L0	CAP	2		
17	509-23163-L0	O-RING	2		
18	509-23190-L0	AIR VALVE ASS'Y	2		
19	509-23184-L0	CAP, air valve	2		
20	1W1-23185-L0	CAP	2		
21	1W1-23345-L0-33	BRACKET, under	1		Yamaha Black
22	1W1-23341-L0	SHAFT, steering	1		
23	1W1-23356-L0	BOLT	1		
24	92901-10100	WASHER, spring	1		
25	322-23357-00	NUT	1		
26	90109-08397	BOLT	4		
27	95311-08600	NUT, hexagon	4		
28	92901-08100	WASHER, spring	4		
29	90201-08544	WASHER, plate	4		
30	1W1-23317-01	HOLDER, wire	1		
31	1W1-23389-00	GUIDE, wire	1		
32	509-23158-L0	PACKING	2		

Fig. 19 FRONT FORK (Except IRAN)



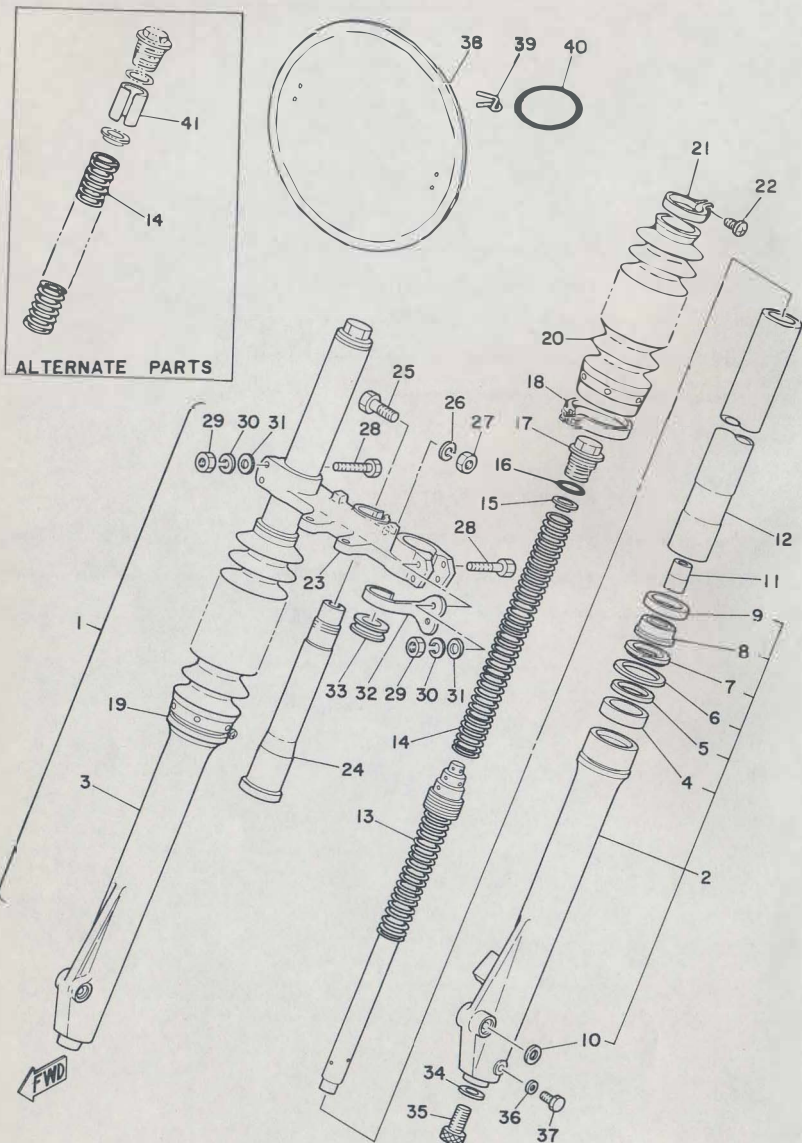
Ref. No.	Part No.	Description	Q'ty	Applicable Machine No.	Remarks
19-33	278-23181-50	BOLT, hexagon sockethead	2		
34	122-23129-00	GASKET, drain plug	2		
35	122-23119-01	PLUG, drain	2		
36	1W1-23318-L0	CLIP, front fork	1		
37	509-23489-L0	BOOT BAND COMP.	1		
38	2K6-23191-L0	BOOT	2		Yellow
	1W1-23191-L0	BOOT	2		Black
39	341-92090-60	BAND, boot	2		
40	509-23194-L0	SCREW	2		
41	2K8-23485-00	PLATE, number	1		
42	431-23486-02	STAY, number plate	2		
43	93210-69355	O-RING	2		

ALTERNATE PARTS Lee Waldje Craig Scott Chris Koira

12	1W1-23141-10	SPRING, front fork (K=0.223 kg/mm)	2		Soft (Use spacer 1W1-23118-10 with set)
	1W1-23141-20	SPRING, front fork (K=0.279 kg/mm)	2		Hard (Use spacer 1W1-23118-10 with set)
14	1W1-23118-10	SPACER	2		

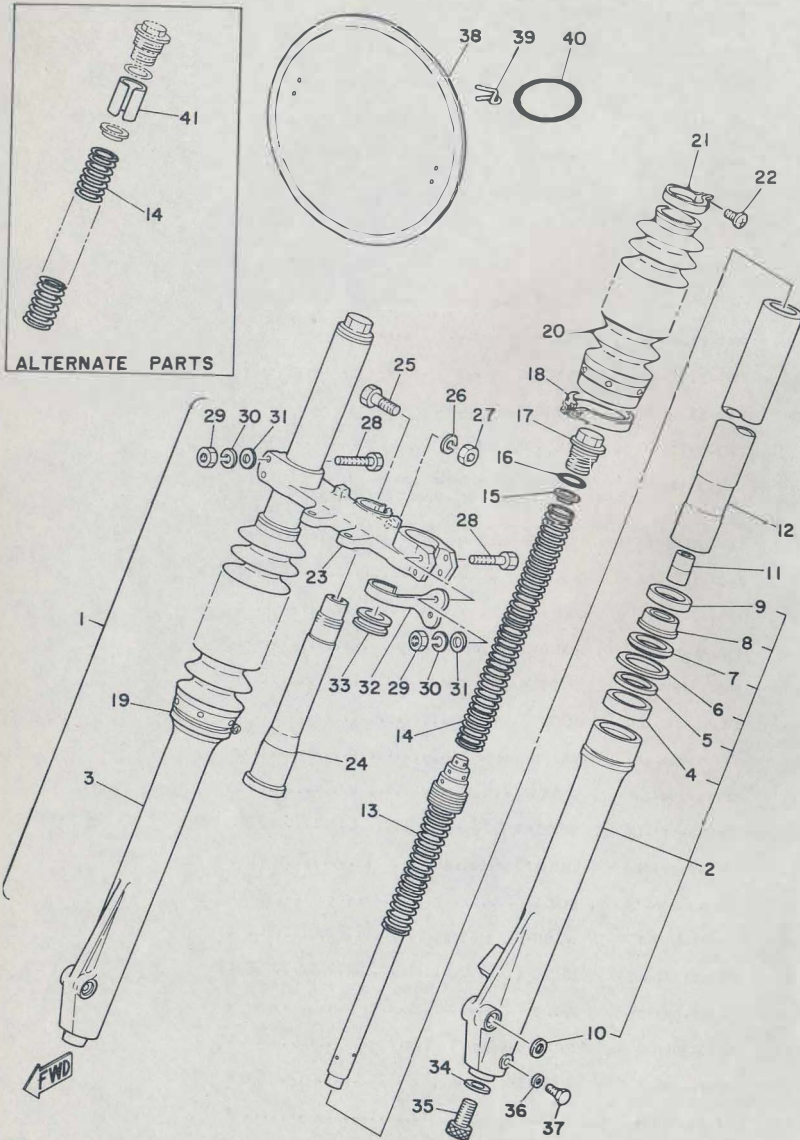


Fig. 20 FRONT FORK (Exclusive for IRAN)



Ref. No.	Part No.	Description	Q'ty	Applicable Machine No.	Remarks
20- 1	1W2-23101-00	FRONT FORK ASS'Y	1		
2	1W2-23126-01	TUBE, outer left	1		
3	1W2-23136-01	TUBE, outer right	1		
4	1K7-23145-00	OIL SEAL	2		
5	509-23146-L0	WASHER	2		
6	1W1-23156-L0	RING, snap	2		
7	1W1-23153-L0	GUIDE, snap ring	2		
8	1G8-23144-L1	SEAL, dust	2		
9	1W1-23148-L0	CASE, dust seal	2		
10	1W1-23168-L0	WASHER	2		
11	1W1-23173-L0	SPINDLE	2		
12	1W2-23110-00	INNER TUBE COMP.	2		
13	1W2-23170-00	CYLINDER COMP. front fork	2		
14	1W2-23141-00	SPRING, front fork (K <sub>1</sub> =0.326 K <sub>2</sub> =0.442 kg/mm)	2		
15	583-23142-00	SEAT, spring upper	2		
16	240-23114-00	O-RING	2		
17	583-23111-00	CAP	2		
18	1W1-23318-L0	HOLDER, wire	1		
19	509-23489-L0	BOOT BAND COMP.	1		
20	1W1-23191-L0	BOOT	2		
21	341-92090-60	BAND, boot	2		
22	509-23194-L0	SCREW	2		
23	1W1-23345-L0-33	BRACKET, under	1		Yamaha Black
24	1W1-23341-L0	SHAFT, steering	1		
25	1W1-23356-L0	BOLT	1		
26	92901-10100	WASHER, spring	1		
27	322-23357-00	NUT	1		
28	90109-08397	BOLT	4		
29	95311-08600	NUT, hexagon	4		
30	92901-08100	WASHER, spring	4		
31	90201-08554	WASHER, plate	4		

Fig. 20 FRONT FORK (Exclusive for IRAN)



Ref. No.	Part No.	Description	Q'ty	Applicable Machine No.	Remarks
20-32	1W1-23317-01	. HOLDER, wire .....	1.		
33	1W1-23389-00	. GUIDE, wire .....	1		
34	509-23158-L0	. PACKING .....	2		
35	1T3-23181-50	. BOLT .....	2		
36	122-23129-00	. GASKET, drain plug .....	2		
37	122-23119-01	. PLUG, drain .....	2		
38	2K8-23485-00	PLATE, number .....	1		
39	431-23486-02	STAY, number plate .....	2		
40	93210-69355	O-RING .....	2		

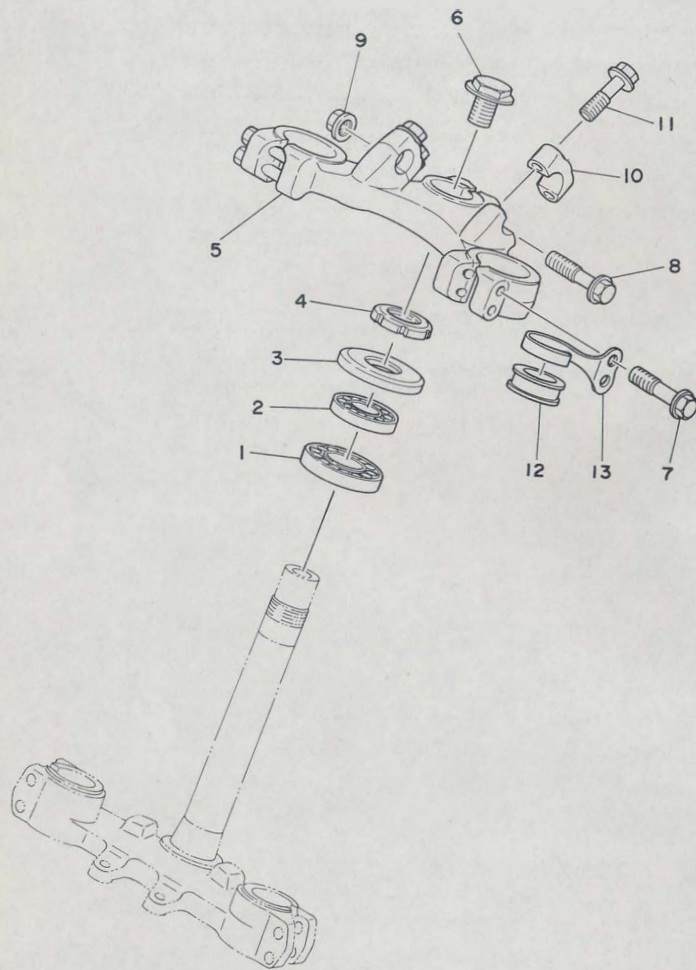
ALTERNATE PARTS

14	1W2-23141-10	SPRING, front fork (K <sub>1</sub> =0.228 K <sub>2</sub> =0.309 kg/mm) .....	2		Soft (Use spacer with set)
	1W2-23141-20	SPRING, front fork (K <sub>1</sub> =0.423 K <sub>2</sub> =0.575 kg/mm) .....	2		Hard (Use spacer with set)
41	1W2-23118-10	SPACER (27φ-40L) .....	2		





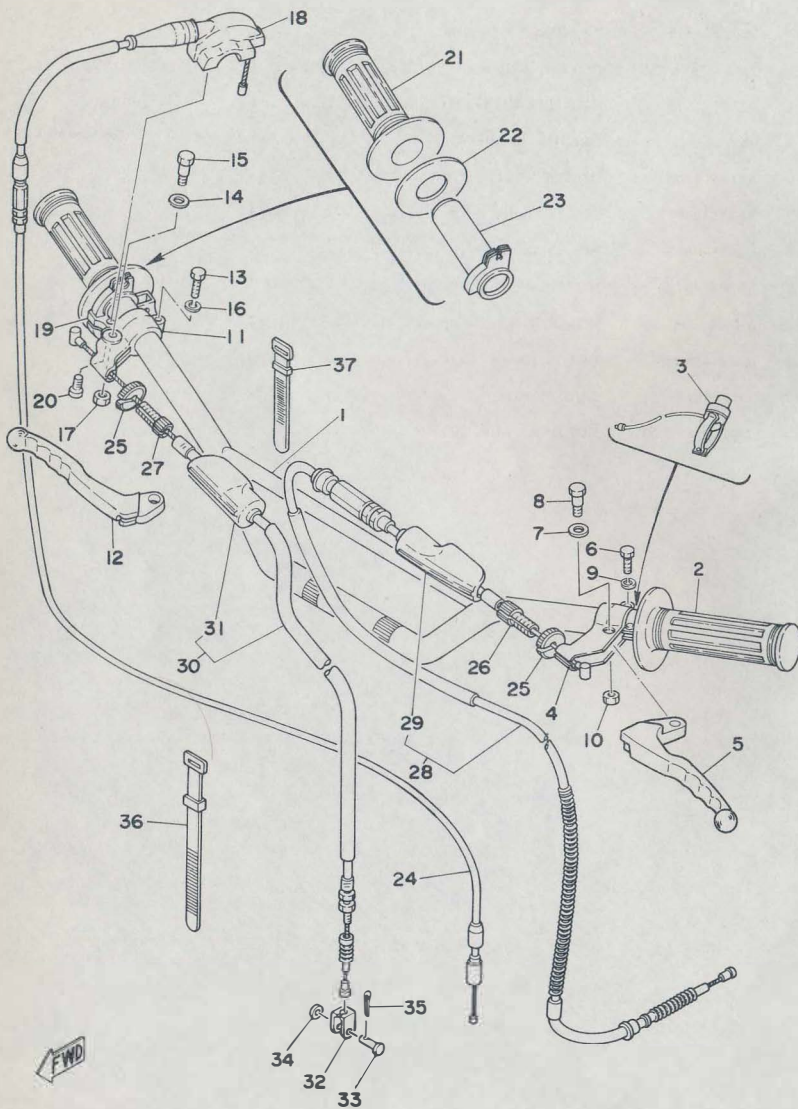
Fig. 21 STEERING



Ref. No.	Part No.	Description	Q'ty	Applicable Machine No.	Remarks
21- 1	93332-00008	BEARING	1		
2	93332-00001	BEARING	1		
3	1W1-23416-00	COVER, ball race	1		
4	90179-25033	NUT (137-23454-00)	1		
5	1W1-23435-01-98	CROWN, handle	1		Low Gloss Black
6	90105-14060	BOLT	1		
7	95821-08040	BOLT, flange	4		
8	95821-08055	BOLT, flange	1		
9	95701-08100	NUT, flange	1		
10	1E6-23441-00	HOLDER, handle upper	2		
11	95821-08035	BOLT, flange	4		
12	1W1-23389-00	GUIDE, wire	1		
13	1W1-23317-01	HOLDER, wire	1		

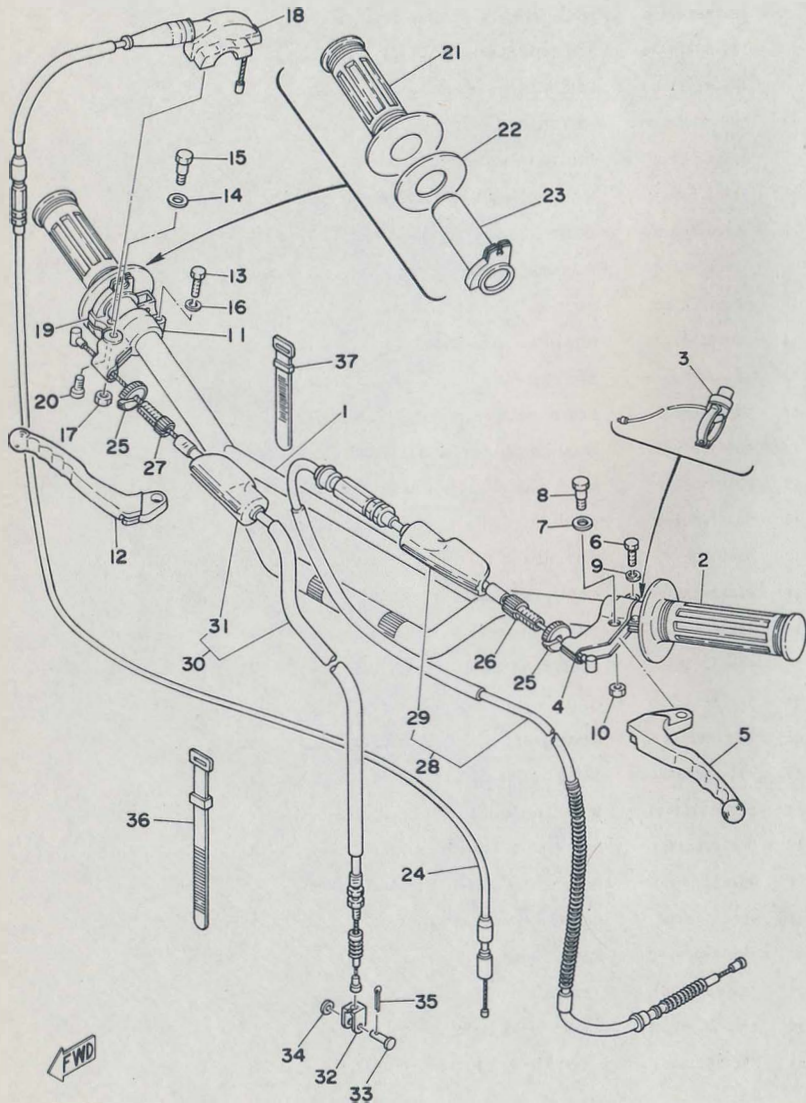
FWD

Fig. 22 HANDLE · WIRE



Ref. No.	Part No.	Description	Q'ty	Applicable Machine No.	Remarks
22- 1	1W1-26111-02	HANDLE	1		Low Gloss Black
2	583-26241-00	GRIP, left	1		
3	1J4-83976-00	SWITCH, handle l	1		
4	461-82911-00	HOLDER, lever left	1		
5	2K6-83912-00	LEVER, left	1		
6	97301-06022	BOLT, hexagon	1		
7	90201-08083	WASHER, plate (156-27226-00)	1		
8	90109-06410	BOLT	1		
9	92901-06100	WASHER, spring	1		
10	95601-06100	NUT, U	1		
11	516-82921-30	HOLDER, lever right	1		
12	2K6-83922-00	LEVER, right	1		
13	97301-06022	BOLT, hexagon	1		
14	90201-08083	WASHER, plate (156-27226-00)	1		
15	90109-06410	BOLT	1		
16	92901-06100	WASHER, spring	1		
17	95601-06100	NUT, U	1		
18	322-26281-00	CAP, grip upper	1		
19	322-26282-00	CAP, grip under	1		
20	98503-05015	SCREW, panhead	2		
21	583-26242-00	GRIP, right	1		
22	1W1-26249-00	RING, leaf	1		
23	322-26243-00	TUBE, guide	1		
24	2K8-26311-01	WIRE, throttle l	1		
25	90179-08148	NUT (168-26344-00)	2		
26	90123-08013	BOLT, wire adjusting (156-26346-00)	1		
27	90123-08046	BOLT, wire adjusting	1		
28	2K5-26335-00	WIRE, clutch	1		
29	382-26372-01	COVER, lever	1		
30	1W1-26341-01	WIRE, brake front	1		
31	382-26372-01	COVER, lever	1		

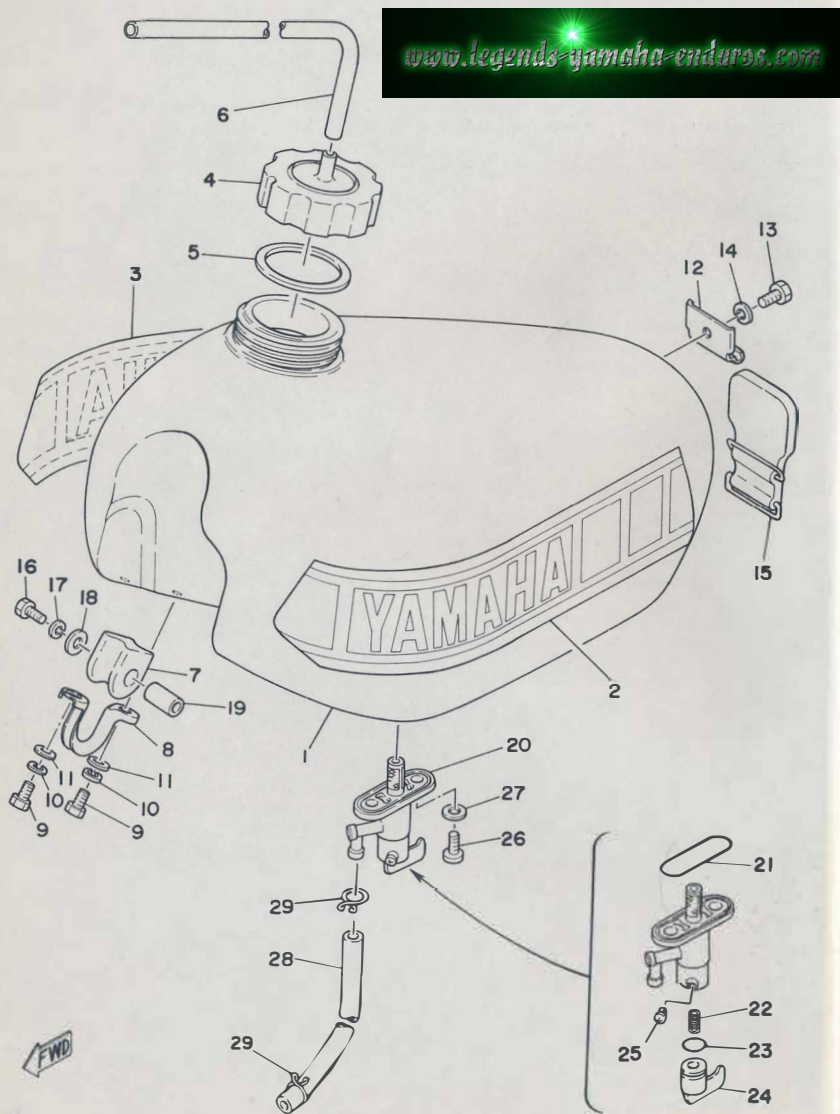
Fig. 22 HANDLE · WIRE



Ref. No.	Part No.	Description	Qty	Applicable Machine No.	Remarks
22-32	156-26347-00	JOINT, wire	1		
33	90240-08012	PIN, with hole (156-27229-00)	1		
34	90201-08083	WASHER, plate (156-27226-00)	1		
35	91401-20012	PIN, cotter	1		
36	437-83936-10	BAND, switch cord	1		
37	437-83936-00	BAND, switch cord	3		

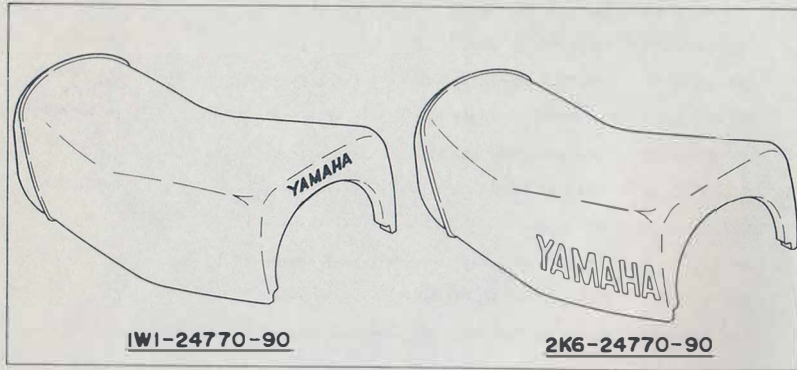
FWD

Fig. 23 FUEL TANK

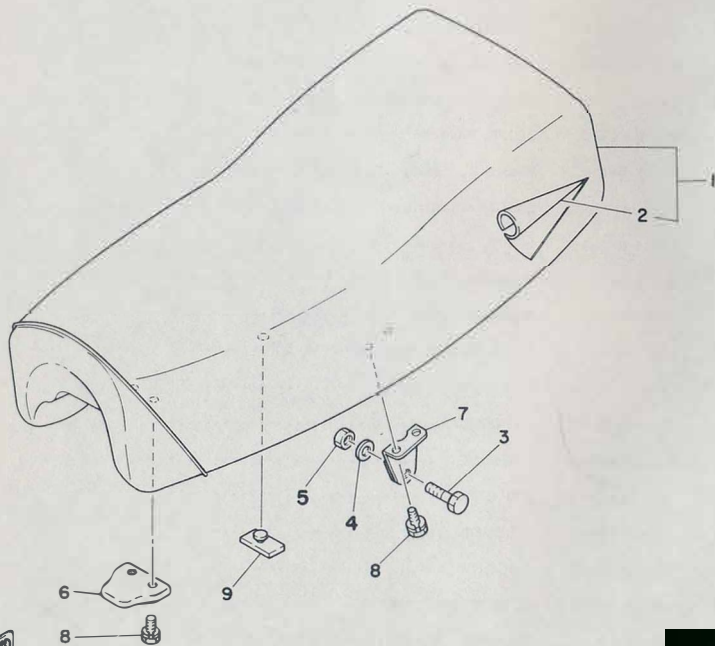


Ref. No.	Part No.	Description	Q'ty	Applicable Machine No.	Remarks
23- 1	1W1-24110-00	FUEL TANK COMP. ....	1		Competition Yellow
	1W1-24110-10	FUEL TANK COMP. ....	1		Clean White
2	2K6-24244-20	GRAPHIC, fuel tank left ....	1		for Competition Yellow
	2K6-24244-30	GRAPHIC, fuel tank left ....	1		for Clean White
3	2K6-24245-20	GRAPHIC, fuel tank right ....	1		for Competition Yellow
	2K6-24245-30	GRAPHIC, fuel tank right ....	1		for Clean White
4	1W1-24611-00	BODY, cap ....	1		
5	1W1-24612-00	GASKET, tank cap ....	1		
6	90445-09117	HOSE (170-21766-00 5-540) ....	1		
7	1W1-24182-01	DAMPER, locating 2 ....	2		
8	1W1-24144-01	HOLDER, damper ....	2		
9	97301-06012	BOLT, hexagon ....	4		
10	92901-06100	WASHER, spring ....	4		
11	92901-06600	WASHER, plate ....	4		
12	1W1-24192-00	BRACKET, fuel tank ....	1		
13	97301-06012	BOLT, hexagon ....	1		
14	92901-06100	WASHER, spring ....	1		
15	1W1-24173-00	BAND, tankfitting 1 ....	1		
16	97321-06035	BOLT, hexagon ....	2		
17	92901-06100	WASHER, spring ....	2		
18	90201-06407	WASHER, plate ....	2		
19	90387-07393	COLLAR (308-84557-00 7-10-20) ....	2		
20	2K5-24500-00	FUEL COCK ASS'Y ....	1		
21	214-24512-00	GASKET, body ....	1		
22	1A0-24529-01	SPRING ....	1		
23	1A0-24512-00	O-RING ....	1		
24	1A0-24524-01	LEVER, cock ....	1		
25	619-24535-00	SCREW ....	1		
26	90149-06011	SCREW (256-24143-00) ....	2		
27	90202-06010	WASHER, plate (178-14766-00) ....	2		
28	90445-11151	HOSE (145-24311-00 7-245) ....	1		
29	90467-10008	CLIP (143-24356-00) ....	2		

Fig. 24 SEAT

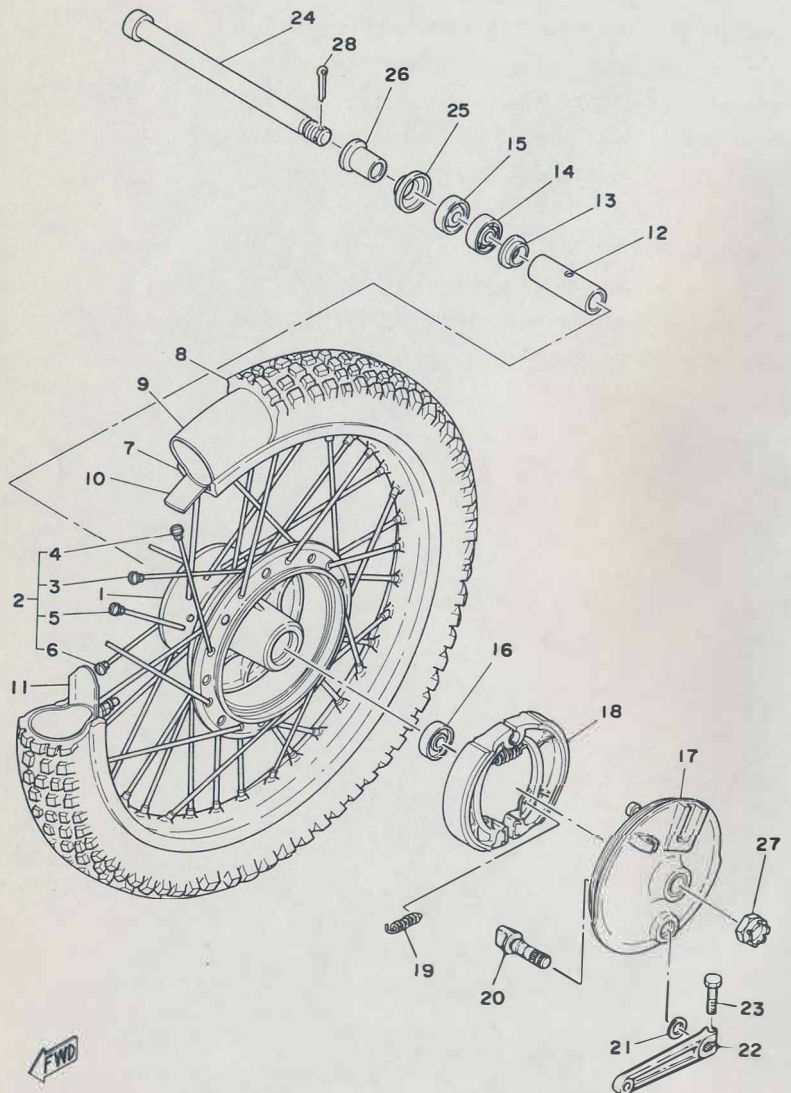


Ref. No.	Part No.	Description	Q'ty	Applicable Machine No.	Remarks
24- 1	1W1-24770-90	SEMI DOUBLE SEAT ASS'Y .....	1		
	2K6-24770-90	SEMI DOUBLE SEAT ASS'Y .....	1		for Europe, Japan, Oceania
2	1W1-24771-00	COVER, seat .....	1		
	2K6-24771-00	COVER, seat .....	1		for Europe, Japan, Oceania
3	97301-06035	BOLT, hexagon .....	2		
4	92901-06200	WASHER, plain .....	2		
5	95601-06100	NUT, U .....	2		
6	1M1-24748-00	BRACKET, front .....	1		
7	1W1-24738-00	BRACKET, seat rear .....	2		
8	90101-06304	BOLT, hexagon head with washer .....	6		
9	509-24724-00	DAMPER, seat .....	6		



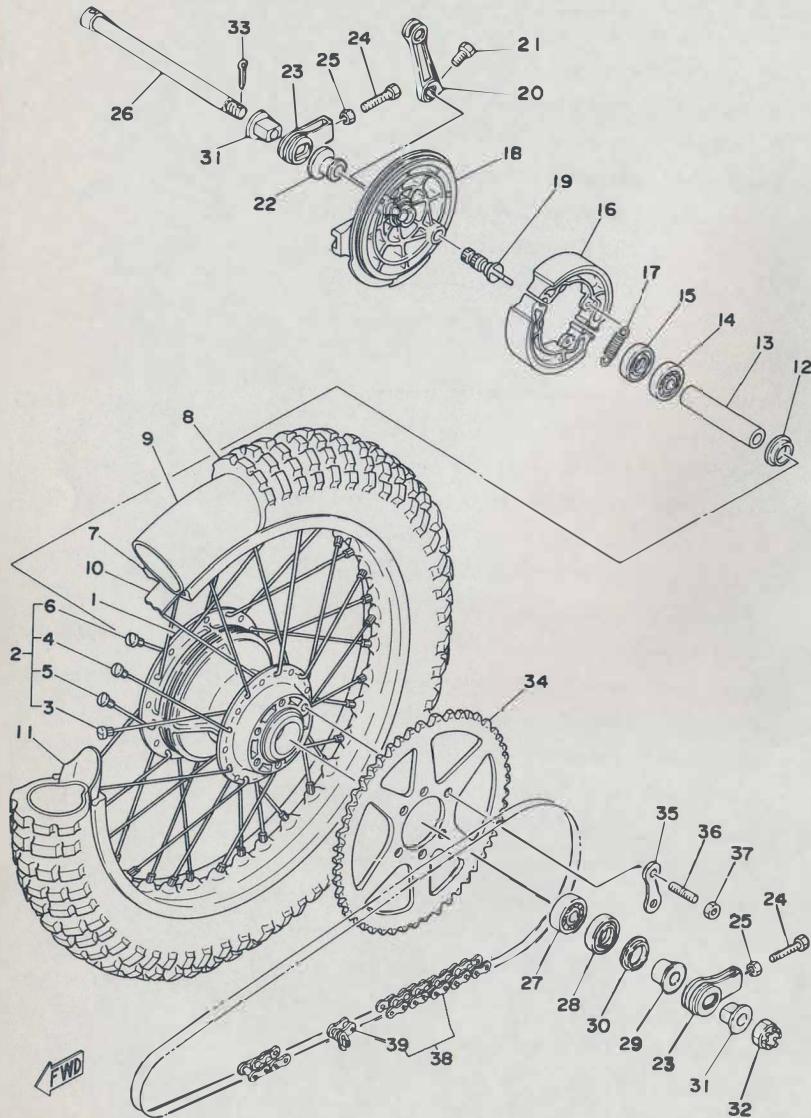
[www.legends-yamaha-enduros.com](http://www.legends-yamaha-enduros.com)

Fig. 25 FRONT WHEEL



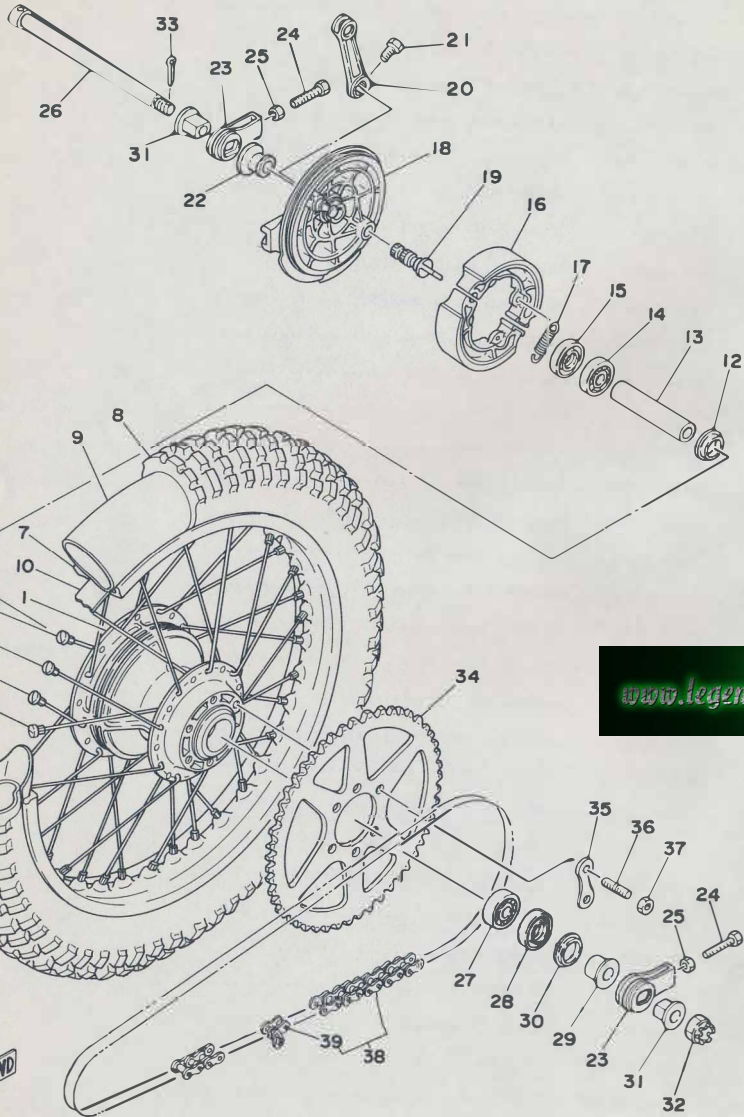
Ref. No.	Part No.	Description	Qty	Applicable Machine No.	Remarks
25- 1	1K7-25111-10-98	HUB, front	1		Low Gloss Black
2	1K7-25104-00	SPOKE SET, front	1s		
3	1K7-25196-90	SPOKE SET, inner left (10 PCS)	1s		
4	1K7-25197-90	SPOKE SET, outer left (10 PCS)	1s		
5	1K7-25179-90	SPOKE SET, inner right (10 PCS)	1s		
6	1K7-25189-90	SPOKE SET, outer right (10 PCS)	1s		
7	94416-21198	RIM, front (1.60-21A)	1		
8	94130-21376	TIRE, front (3.00-21-4PR)	1		INOUE
	94130-21248	TIRE, front (3.00-21-4PR)	1		DUNLOP Exclusive for Japan
9	94230-21126	TUBE, front (3.00-21)	1		
10	94330-21088	BAND, rim (3.00-21)	1		
11	1T1-25194-00	SPACER, bead	1		
12	90560-15116	SPACER (322-25117-00)	1		
13	146-25116-00	FLANGE, spacer	1		
14	93306-20205	BEARING (B6202)	1		
15	93102-20009	OIL SEAL (SD-20-35-7)	1		
16	93306-20203	BEARING (B6202RS)	1		
17	1W1-25121-01-98	PLATE, brake shoe	1		Low Gloss Black
18	322-25130-00	BRAKE SHOE COMP.	2		
19	90506-16036	SPRING, tension (183-25333-00)	2		
20	322-25151-00	CAMSHAFT	1		
21	137-25159-00	SEAL, camshaft	1		
22	322-25155-00	LEVER, camshaft	1		
23	90101-06291	BOLT, hexagon	1		
24	1W1-25181-00	SHAFT, wheel	1		
25	322-25118-00	COVER, hub dust	1		
26	90387-15600	COLLAR	1		
27	90171-14020	NUT, castle	1		
28	91401-30030	PIN, cotter	1		

Fig. 26 REAR WHEEL



Ref. No.	Part No.	Description	Q'ty	Applicable Machine No.	Remarks
26- 1	1W1-25311-00-98	HUB, rear	1		Low Gloss Black
2	537-25304-00	SPOKE SET, rear	1s		
3	537-25396-90	SPOKE SET, inner left (10 PCS)	1s		
4	537-25397-90	SPOKE SET, outer left (10 PCS)	1s		
5	537-25391-90	SPOKE SET, inner right (10 PCS)	1s		
6	537-25392-90	SPOKE SET, outer right (10 PCS)	1s		
7	94418-18141	RIM, rear (1.85-18E)	1		
8	94141-18270	TIRE, rear (4.10-18-4PR)	1		INOUE
	94140-18263	TIRE, rear (4.00-18-4PR)	1		DUNLOP Exclusive for Japan
9	94235-18022	TUBE, rear (3.50-18)	1		
10	94325-18043	BAND, rim (2.50-18)	1		
11	537-25394-00	SPACER, bead	2		
12	148-25115-00	FLANGE, spacer	1		
13	248-25317-00	SPACER, bearing	1		
14	93306-20203	BEARING (B6202Z)	1		
15	93104-22018	OIL SEAL (SO-22-35-5)	1		
16	437-25330-00	BRAKE SHOE COMP.	2		
17	90506-16036	SPRING, tension (183-25333-00)	2		
18	2K6-25321-00-98	PLATE, brake shoe	1		Low Gloss Black
19	2A6-25351-00	CAMSHAFT	1		
20	431-25355-00	LEVER, camshaft	1		
21	90101-06291	BOLT, hexagon	1		
22	90387-15658	COLLAR	1		
23	2K6-25388-00	PULLER, chain	2		
24	90101-08034	BOLT, hexagon (168-25379-00)	2		
25	95301-08700	NUT, hexagon	2		
26	2K6-25381-00	SHAFT, wheel	1		
27	93306-30203	BEARING (B6202Z)	1		
28	93106-26005	OIL SEAL (DD-26-42-8)	1		
29	90387-15659	COLLAR	1		
30	431-25367-00	COVER, dust	1		
31	90381-15029	BUSHING, solid	1		

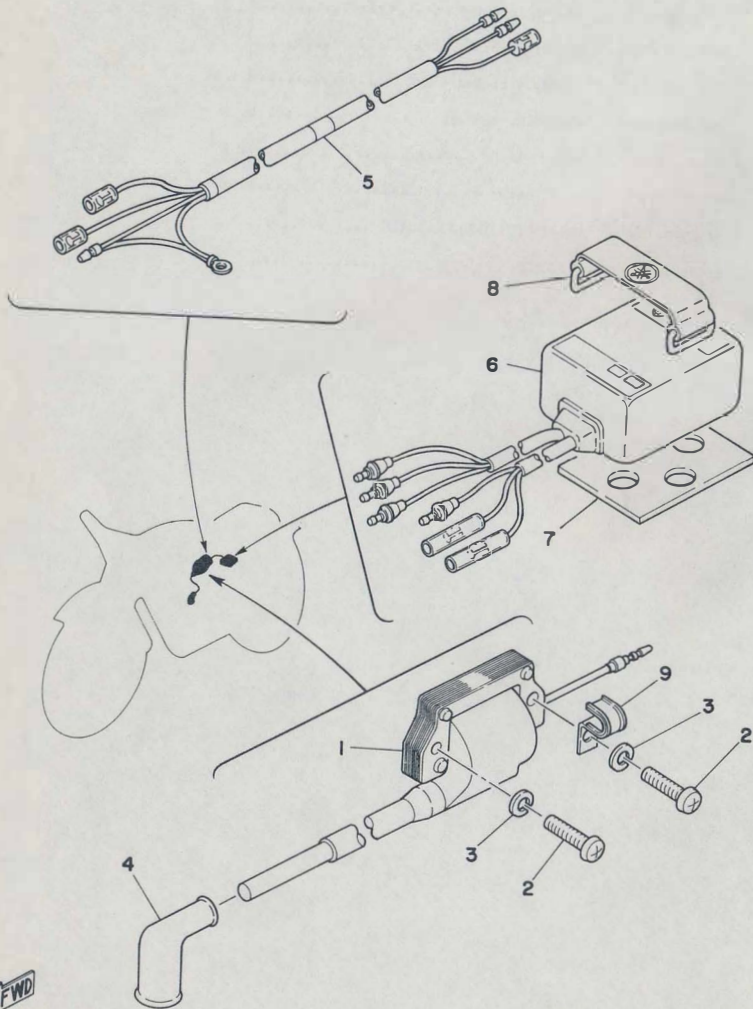
Fig. 26 REAR WHEEL



Ref. No.	Part No.	Description	Q'ty	Applicable Machine No.	Remarks
26-32	90171-14020	NUT, castle	1		
33	91401-30030	PIN, cotter	1		
34	1W1-25449-00	GEAR, sprocket wheel (49T)	1	UR	STD
	1W1-25451-00	GEAR, sprocket wheel (51T)			
	1W1-25453-00	GEAR, sprocket wheel (53T)			
35	1G8-25412-00	WASHER, special	3		
36	90116-10221	BOLT, stud	6		
37	90170-10219	NUT, hexagon	6		
38	94580-11104	CHAIN (D1D520TR-104L)	1		
39	94680-11001	JOINT, chain	1		



Fig. 27 ELECTRICAL



Ref. No.	Part No.	Description	Q'ty	Applicable Machine No.	Remarks
27-	1	565-82310-10	IGNITION COIL ASS'Y	1	
	2	92501-06025	SCREW, panhead	2	
	3	92901-06100	WASHER, spring	2	
	4	294-82370-00	PLUG CAP ASS'Y	1	
	5	1W1-82590-02	WIRE HARNESS ASS'Y	1	
	6	509-85540-10	C. D. I. UNIT ASS'Y	1	
	7	1M2-85547-00	DAMPER	1	
	8	122-82131-00	BAND, battery	1	
	9	90462-05005	CLAMP (363-15485-01)	1	

Lee Waldie Craig Scott Chris Koira

FWD

# REPAIR KIT

[www.legends-yamaha-enduros.com](http://www.legends-yamaha-enduros.com)



## Fig. 28 REPAIR KIT

Ref. No.	Part No.	Description	Q'ty	Applicable Machine No.	Remarks
28- 1	2K6-11630-00	PISTON ASS'Y (STD)	1		
	2K6-11630-10	PISTON ASS'Y (1st O.S)	1		
	2K6-11630-20	PISTON ASS'Y (2nd O.S)	1		
	2K6-11630-30	PISTON ASS'Y (3rd O.S)	1		
	2K6-11630-40	PISTON ASS'Y (4th O.S)	1		
2	2K6-11631-00-97	PISTON (55.97mm STD)	1	U.R 1	
	2K6-11631-00-98	PISTON (55.98mm STD)	1		
	2K6-11635-00	PISTON (56.25mm 1st O.S)	1	Ref. No. 38	
	2K6-11636-00	PISTON (56.50mm 2nd O.S)	1		
	2K6-11637-00	PISTON (56.75mm 3rd O.S)	1		
	2K6-11638-00	PISTON (57.00mm 4th O.S)	1		
	2K6-11639-00	PISTON (57.25mm 5th O.S)	1		
3	2K6-11601-00	PISTON RING SET (STD)	1s	39	
	2K6-11601-10	PISTON RING SET (1st O.S)	1s		
	2K6-11601-20	PISTON RING SET (2nd O.S)	1s		
	2K6-11601-30	PISTON RING SET (3rd O.S)	1s		
	2K6-11601-40	PISTON RING SET (4th O.S)	1s		
4	137-11633-00	PIN, piston	1		3-11
5	93450-17025	CIRCLIP (137-11634-00)	2		3-12
6	2K5-11650-00	CONNECTING ROD ASS'Y	1		
7	1G8-11651-00	ROD, connecting	1		3-4
8	2K5-11681-00	PIN, crank	1		3-5
9	93310-422E6	BEARING, con-rod big end	1		3-6
10	90209-22071	WASHER (164-11685-00)	2		6-2
11	93310-216A3	BEARING, con-rod small end	1		3-10
12	2K6-W0001-00	GASKET KIT	1s		
13	90430-12038	GASKET (132-15353-00)	1		1-9
14	1W1-11351-00	GASKET, cylinder	1		1-18
15	1W1-11181-00	GASKET, cylinder head	1		1-20
16	93210-11073	O-RING (2.4-10.8)	2		1-29
17	1W1-15455-00	GASKET, crankcase cover left	1		2-3

Ref. No.	Part No.	Description	Q'ty	Applicable Machine No.	Remarks
28-18	1W1-15451-00	GASKET, crankcase cover right	1		Ref. No. 2-6
19	93210-14104	O-RING (2.4-13.8)	1		2-10
20	90430-06016	GASKET (838-15384-00)	1		2-12
21	93210-18023	O-RING (1.2-17.6)	1		3-17
22	90430-08069	GASKET (452-16387-00)	1		4-24
23	311-13621-01	PACKING, valve seat	1		9-23
24	483-14184-00	GASKET, float chamber	1		10-12
25	248-14623-00	GASKET	1		11-2
26	152-14613-00	GASKET, exhaust pipe	1		11-4
27	1W1-W0003-00	OIL SEAL KIT	1s		
28	93102-25144	OIL SEAL (SD-25-40-8)	1		3-14
29	93103-28100	OIL SEAL (SW-28-40-8)	1		3-16
30	93104-14004	OIL SEAL (SO-14-25-5)	1		4-22
31	93102-26042	OIL SEAL (SD-26-38-5)	1		5-30
32	93101-12060	OIL SEAL (S-12-21-4)	1		7-4
33	93101-17062	OIL SEAL (S-17-25-4)	1		8-16

# NUMERICAL INDEX

[www.legends-yamaha-enduros.com](http://www.legends-yamaha-enduros.com)



## NUMERICAL INDEX

Ref No.	Part No.	Ref No.	Part No.	Ref No.	Part No.
23-23	1A0-24512-00	10-43	1W1-14175-01	5-17	1W1-17261-00
23-24	1A0-24524-01	9- 1	1W1-14411-01	5- 1	1W1-17411-00
23-22	1A0-24529-01	9- 3	1W1-14412-02	5-13	1W1-17421-00
21-10	1E6-23441-00	9- 2	1W1-14450-02	5-32	1W1-17461-20
3- 4	1G8-11651-00	9- 4	1W1-14452-00	5-11	1W1-17471-01
10-40	1G8-14123-00	9-14	1W1-14453-00	7- 5	1W1-18101-02
2- 9	1G8-15362-00	9- 7	1W1-14457-01	7- 1	1W1-18111-01-33
4- 4	1G8-16371-00	11- 8	1W1-14753-01	6-12	1W1-18140-00
5-32	1G8-17461-10	1- 1	1W1-15111-02	6-13	1W1-18177-00
5-32	1G8-17461-30	1- 2	1W1-15121-01	6- 3	1W1-18185-00
19- 6	1G8-23144-L1	5-35	1W1-15381-00	7-10	1W1-18197-01
20- 8	1G8-23144-L1	2- 1	1W1-15411-00	6- 9	1W1-18511-01
26-35	1G8-25412-00	2- 2	1W1-15421-01	6-10	1W1-18512-01
12- 1	1G8-85500-10	2- 5	1W1-15431-00	6- 7	1W1-18531-00
12- 2	1G8-85550-10	2- 6	1W1-15451-00	6- 8	1W1-18535-00
22- 3	1J4-83976-00	2- 3	1W1-15455-00	6- 1	1W1-18541-00
13-11	1K6-14729-00	8- 1	1W1-15611-02-33	6- 5	1W1-18561-00
20- 4	1K7-23145-00	8-17	1W1-15618-01	13- 2	1W1-21410-00
25- 2	1K7-25104-00	8- 2	1W1-15621-01	18- 1	1W1-21511-00
25- 1	1K7-25111-10-98	8-10	1W1-15641-00	18- 1	1W1-21511-10
25- 5	1K7-25179-90	8- 8	1W1-15660-00	18-12	1W1-21620-01
25- 6	1K7-25189-90	8-15	1W1-15666-00	13- 9	1W1-21711-00
25- 3	1K7-25196-90	3-19	1W1-16111-00	13- 9	1W1-21711-10
25- 4	1K7-25197-90	4- 2	1W1-16150-00	13-10	1W1-21721-02
9-18	1L8-13610-00	4- 1	1W1-16301-00	13-10	1W1-21721-11
9-19	1L8-13613-00	4- 7	1W1-16351-00	14-34	1W1-22128-00
10-34	1M1-14169-00	4-13	1W1-16356-00	14- 2	1W1-22141-00
18-13	1M1-21621-00	4-18	1W1-16357-00	14-25	1W1-22178-00
24- 6	1M1-24748-00	4-10	1W1-16358-00	15-12	1W1-22216-00
27- 7	1M2-85547-00	4-19	1W1-16380-00	16- 2	1W1-22216-00
25-11	1T1-25194-00	5- 7	1W1-17121-00	15-11	1W1-22219-00
20-35	1T3-23181-50	5- 5	1W1-17131-01	16- 3	1W1-22219-00
28-27	1W1-W0003-00	5- 2	1W1-17151-00	15- 5	1W1-22221-00
1-20	1W1-11181-00	5- 6	1W1-17161-00	16-11	1W1-22221-00
1-18	1W1-11351-00	5-22	1W1-17211-01	15-14	1W1-22223-00
3- 2	1W1-11412-01	5-14	1W1-17221-01	16-17	1W1-22223-00
3- 3	1W1-11422-01	5-20	1W1-17231-01	15-13	1W1-22224-00
9-17	1W1-13565-00	5-19	1W1-17241-01	15-19	1W1-22226-00
10-41	1W1-14171-00	5-21	1W1-17251-00	16-22	1W1-22226-00

## NUMERICAL INDEX

Ref No.	Part No.	Ref No.	Part No.	Ref No.	Part No.
15- 4	1W1-22228-00	20-25	1W1-23356-L0	20-12	1W2-23110-00
16-10	1W1-22228-00	19-31	1W1-23389-00	20-41	1W2-23118-10
15-17	1W1-22472-00	20-33	1W1-23389-00	20- 3	1W2-23126-01
16-13	1W1-22742-00	21-12	1W1-23389-00	20- 2	1W2-23136-01
15- 3	1W1-22493-00	21- 3	1W1-23416-00	20-14	1W2-23141-00
16-12	1W1-22493-00	21- 5	1W1-23435-01-98	20-14	1W2-23141-10
15-10	1W1-22497-00	23- 1	1W1-24110-00	20-14	1W2-23141-20
16- 4	1W1-22497-00	23- 1	1W1-24110-10	20-13	1W2-23170-00
19-16	1W1-23111-L0	23- 8	1W1-24144-01	17- 1	1W2-27311-01
19-15	1W1-23114-L0	23-15	1W1-24173-00	17- 9	1W4-27411-00
19-14	1W1-23118-L0	13-17	1W1-24181-00	17-10	1W4-27421-00
19-14	1W1-23118-10	23- 7	1W1-24182-01	7-12	102-18137-00-10
19-12	1W1-23141-L0	13-18	1W1-24183-00	12-10	109-81328-11
19-12	1W1-23141-10	23-12	1W1-24192-00	19-35	122-23119-01
19-12	1W1-23141-20	23- 4	1W1-24611-00	20-37	122-23119-01
19-13	1W1-23142-L0	23- 5	1W1-24612-00	19-34	122-23129-00
19- 4	1W1-23145-L0	24- 7	1W1-24738-00	20-36	122-23129-00
19- 7	1W1-23148-L0	24- 1	1W1-24770-90	27- 8	122-82131-00
20- 9	1W1-23148-L0	24- 2	1W1-24771-00	10-33	127-14161-00
20- 7	1W1-23153-L0	25-17	1W1-25121-01-98	10-11	127-14186-00
19- 5	1W1-23156-L0	25-24	1W1-25181-00	7- 2	132-18113-01
20- 6	1W1-23156-L0	26- 1	1W1-25311-00-98	3-11	137-11633-00
19- 8	1W1-23168-L0	26-34	1W1-25449-00	10-39	137-14134-00
20-10	1W1-23168-L0	26-34	1W1-25451-00	10- 3	137-14143-54
19- 9	1W1-23173-L0	26-34	1W1-25453-00	10- 3	137-14143-56
20-11	1W1-23173-L0	22- 1	1W1-26111-02	10- 3	137-14143-58
19-20	1W1-23185-L0	22-22	1W1-26249-00	4- 6	137-16325-70
19-38	1W1-23191-L0	22-30	1W1-26341-01	5-27	137-17417-00-05
20-20	1W1-23191-L0	17-14	1W1-27211-01-33	25-21	137-25159-00
19-30	1W1-23317-01	17- 5	1W1-27412-10	25-13	146-25116-00
20-32	1W1-23317-01	17- 6	1W1-27422-12	26-12	148-25115-00
21-13	1W1-23317-01	13-15	1W1-28100-10	11- 4	152-14613-00
19-36	1W1-23318-L0	13-16	1W1-2811A-00	22-32	156-26347-00
20-18	1W1-23318-L0	27- 5	1W1-82590-02	10-22	164-14137-00
19-22	1W1-23341-L0	16- 1	1W2-22210-01	10- 2	193-14142-60
20-24	1W1-23341-L0	16-16	1W2-22224-00	7- 8	2A6-18120-01
19-21	1W1-23345-L0-33	16-14	1W2-22234-00	26-19	2A6-25351-00
20-23	1W1-23345-L0-33	16-20	1W2-22401-01	3- 1	2K5-11400-00
19-23	1W1-23356-L0	20- 1	1W2-23101-00	28- 6	2K5-11650-00

## NUMERICAL INDEX

Ref No.	Part No.	Ref No.	Part No.	Ref No.	Part No.
3- 5	2K5-11681-00	16- 8	2K6-22214-00	11- 2	248-14623-00
11- 3	2K5-14612-00	15-18	2K6-22401-00	8-11	248-15654-00
23-20	2K5-24500-00	15-16	2K6-22489-00	26-13	248-25317-00
22-28	2K5-26335-00	16-19	2K6-22489-00	10-42	256-14135-00
28-12	2K6-W0001-00	19- 1	2K6-23101-L0	10-44	275-14178-00
1-21	2K6-11111-00	19-10	2K6-23110-L0	19-33	278-23181-50
1-19	2K6-11311-00	19- 2	2K6-23126-L0	27- 4	294-82370-00
3- 9	2K6-11601-00	19- 3	2K6-23136-L0	1-15	304-15128-00
3- 9	2K6-11601-10	19-11	2K6-23170-L0	10- 9	310-14185-00
3- 9	2K6-11601-20	19-38	2K6-23191-L0	10-10	310-14187-00
3- 9	2K6-11601-40	23- 2	2K6-24244-20	10-49	310-14197-00
28- 1	2K6-11630-00	23- 3	2K6-24245-20	9-20	311-13616-01
28- 1	2K6-11630-10	23- 3	2K6-24245-30	9-23	311-13621-01
28- 1	2K6-11630-20	24- 1	2K6-24770-90	10-18	313-14146-00
28- 1	2K6-11630-30	24- 2	2K6-24771-00	19-25	322-23357-00
28- 1	2K6-11630-40	26-18	2K6-25321-00-98	20-27	322-23357-00
3- 8	2K6-11631-00-97	26-26	2K6-25381-00	25-25	322-25118-00
3- 8	2K6-11631-00-98	26-23	2K6-25388-00	25-18	322-25130-00
3- 8	2K6-11635-00	17-18	2K6-27231-00	25-20	322-25151-00
3- 8	2K6-11636-00	17- 1	2K6-27311-00	25-22	322-25155-00
3- 8	2K6-11637-00	22- 5	2K6-83912-00	22-12	322-26243-00
3- 8	2K6-11638-00	22-12	2K6-83922-00	22-18	322-26281-00
10- 1	2K6-14101-00	14-41	2K8-22147-00	22-19	322-26282-00
10-14	2K6-14115-00	14-15	2K8-22153-00	12-14	322-85553-10
10-15	2K6-14147-00	14-21	2K8-22179-00	12-15	322-85554-10
10-13	2K6-14181-16	14-42	2K8-2219X-00	1-27	328-15316-00
11- 1	2K6-14610-00	19-41	2K8-23485-00	19-39	341-92090-60
13- 1	2K6-21110-01-33	20-38	2K8-23485-00	20-21	341-92090-60
13-21	2K6-2148A-01	22-24	2K8-26311-01	10-27	363-14131-00
18- 7	2K6-21611-00	14-31	2N0-22178-00	10-29	363-14137-00
18- 7	2K6-21611-10	10-35	204-14122-00	22-29	382-26372-01
14- 1	2K6-22110-00-33	23-21	214-24512-00	22-31	382-26372-01
14- 3	2K6-22128-00	10-21	239-14116-22	1-28	401-15317-00
13-22	2K6-22178-00	10-19	239-14141-48	8-13	401-15676-00
15- 1	2K6-22210-00	10- 4	239-14172-20	7- 7	401-18178-00
15- 7	2K6-22213-00	10- 6	239-14190-33	14-12	431-22151-03
16- 7	2K6-22213-00	10- 7	239-14195-00	19-42	431-23486-02
15- 6	2K6-22214-00	14-11	240-22127-00	20-39	431-23486-02
		20-16	240-23114-00		

## NUMERICAL INDEX

Ref No.	Part No.	Ref No.	Part No.	Ref No.	Part No.
26-20	431-25355-00	26-3	537-25396-90	1-11	90116-10278
26-30	431-25367-00	26-4	537-25397-90	1-12	90116-10279
26-16	437-25330-00	11-17	565-14747-00	22-26	90123-08013
22-37	437-83936-00	18-14	565-21746-00	22-27	90123-08046
22-36	437-83936-10	27-1	565-82310-10	23-26	90149-06011
22-4	461-82911-00	12-3	565-85510-10	4-23	90149-08108
10-8	483-14146-00	12-9	565-85515-10	7-14	90149-08111
10-12	483-14184-00	12-4	565-85566-10	4-9	90159-05011
11-10	483-14781-00	12-5	565-85567-10	7-15	90170-08029
10-50	493-14196-00	10-47	583-14918-00	26-37	90170-10219
1-25	498-15371-00	20-17	583-23111-00	4-14	90170-14171
10-32	500-14155-00	20-15	583-23142-00	14-14	90170-16111
10-30	500-14158-00	22-2	583-26241-00	15-8	90170-20213
10-20	509-14112-30	22-21	583-26242-00	16-6	90170-20213
10-26	509-14136-00	23-25	619-24535-00	25-27	90171-14020
10-31	509-14198-00	10-48	737-14137-00	26-32	90171-14020
10-23	509-14274-00	10-36	802-14161-00	17-24	90175-06013
20-5	509-23146-L0	10-46	802-14173-00	14-30	90179-06239
19-32	509-23158-L0	10-45	802-14174-00	22-25	90179-08148
20-34	509-23158-L0	1-22	812-11175-00	14-39	90179-08243
19-17	509-23163-L0	10-37	812-14147-00	1-13	90179-10204
19-19	509-23184-L0	10-38	812-14235-00	3-22	90179-12244
19-18	509-23190-L0	25-23	90101-06291	5-34	90179-16226
19-40	509-23194-L0	26-21	90101-06291	21-4	90179-25033
20-22	509-23194-L0	24-8	90101-06304	13-7	90185-08054
19-37	509-23489-L0	26-24	90101-08034	12-18	90201-06045
20-19	509-23489-L0	17-12	90101-08371	13-13	90201-06067
24-9	509-24724-00	13-3	90105-08099	18-4	90201-06067
27-6	509-85540-10	13-4	90105-08100	18-11	90201-06067
22-11	516-82921-30	13-5	90105-10037	18-17	90201-06067
5-26	525-15651-00	21-6	90105-14060	23-18	90201-06407
10-5	537-14153-00	22-8	90109-06410	22-7	90201-08083
11-9	537-14788-00	22-15	90109-06410	22-14	90201-08083
4-5	537-16321-00	19-26	90109-08397	22-34	90201-08083
13-19	537-21732-00	20-28	90109-08397	11-19	90201-08113
26-2	537-25304-00	14-38	90109-08480	19-29	90201-08544
26-5	537-25391-90	17-2	90109-10473	20-31	90201-08554
26-6	537-25392-90	1-17	90116-08104	17-8	90201-10639
26-11	537-25394-00	26-36	90116-10221	8-3	90201-12541

## NUMERICAL INDEX

Ref No.	Part No.	Ref No.	Part No.	Ref No.	Part No.
13-23	90201-13202	25-26	90387-15600	17-11	90508-20023
14-23	90201-14411	26-22	90387-15658	4-20	90508-20345
14-29	90201-14411	26-29	90387-15659	8-14	90508-26346
17-16	90201-14212	3-18	90387-20488	7-11	90508-32349
4-21	90201-14217	5-31	90387-20503	14-20	90508-35365
5-8	90201-15563	2-12	90430-06016	25-12	90560-15116
5-23	90201-15563	4-24	90430-08069	4-16	90560-17147
4-3	90201-17550	1-9	90430-12038	2-4	91316-06030
4-17	90201-17550	1-26	90445-07177	2-8	91316-06030
5-3	90201-20266	23-6	90445-09117	1-5	91316-06050
5-15	90201-22555	23-28	90445-11151	1-6	91316-06060
14-5	90201-22680	9-16	90460-49058	1-7	91316-06070
23-27	90202-06010	9-15	90460-64065	1-8	91316-06075
3-21	90204-12007	9-13	90460-77016	8-7	91316-08025
5-18	90209-18135	27-9	90462-05005	17-21	91401-20012
3-7	90209-22071	2-13	90465-10119	22-35	91401-20012
7-16	90215-08014	23-29	90467-10008	14-40	91401-20015
4-15	90215-14144	9-8	90467-20030	14-37	91401-30022
5-33	90215-16127	8-9	90468-26048	25-28	91401-30030
17-19	90240-06040	13-20	90480-12053	26-33	91401-30030
22-33	90240-08012	9-9	90480-14102	1-14	91810-16016
14-35	90240-12060	18-5	90480-14198	1-3	91810-19020
17-23	90249-12008	17-22	90501-10245	1-4	91830-21014
6-11	90250-06013	8-5	90501-10459	2-7	91830-21014
3-23	90280-03017	4-8	90501-20361	13-12	91901-06012
3-20	90282-05005	16-9	90501-80483	12-16	92501-06020
8-18	90336-06030	16-15	90501-85470	9-5	92501-06025
13-14	90339-13005	16-9	90501-90482	27-2	92501-06025
1-10	90340-12005	15-2	90501-98466	1-16	92501-08010
15-20	90380-12051	15-2	90501-98477	2-11	92506-06008
16-21	90380-12051	15-2	90501-98478	5-36	92701-06012
14-8	90380-16056	16-9	90501-99471	9-21	92901-03100
14-7	90380-16063	7-9	90506-08155	10-25	92901-03100
26-31	90381-15029	6-14	90506-09156	12-12	92901-04100
14-9	90386-22097	25-19	90506-16036	12-13	92901-04600
18-6	90387-06388	26-17	90506-16036	10-17	92901-05100
9-10	90387-07391	17-15	90506-20140	12-7	92901-05100
23-19	90387-07393	11-7	90507-20030	12-8	92901-05600
11-18	90387-08258	17-4	90507-29008	9-11	92901-06100

## NUMERICAL INDEX

Ref No.	Part No.	Ref No.	Part No.	Ref No.	Part No.
11- 6	92901-06100	3-14	93102-25144	7- 6	93430-10016
11-12	92901-06100	5-30	93102-26042	7-13	93430-10016
12-17	92901-06100	3-16	93103-28100	5-24	93440-15012
14-27	92901-06100	4-22	93104-14004	5-28	93440-15012
18- 3	92901-06100	26-15	93104-22018	15-15	93440-50058
18- 9	92901-06100	26-28	93106-26005	16-18	93440-50058
18-16	92901-06100	14- 4	93108-35004	3-12	93450-17025
22- 9	92901-06100	14-22	93109-14021	4-25	93503-16010
22-16	92901-06100	14-10	93109-22019	8- 6	93503-16010
23-10	92901-06100	1-29	93210-11073	6- 4	93604-12037
23-14	92901-06100	2-10	93210-14104	15- 9	93604-26132
23-17	92901-06100	3-17	93210-18023	16- 5	93604-26132
27- 3	92901-06100	10-28	93210-40289	6-15	93604-30018
4-11	92901-06200	19-43	93210-69355	25- 8	94130-21248
17-20	92901-06200	20-40	93210-69355	25- 8	94130-21376
24- 4	92901-06200	25-16	93306-20203	26- 8	94140-18263
9- 6	92901-06600	26-14	93306-20203	26- 8	94141-18270
9-25	92901-06600	25-14	93306-20205	25- 9	94230-21126
11-13	92901-06600	3-13	93306-20529	26- 9	94235-18022
14-28	92901-06600	26-27	93306-30203	26-10	94325-18043
23-11	92901-06600	5-10	93306-30304	25-10	94330-21088
11-15	92901-08100	3-15	93306-30406	25- 7	94416-21198
11-20	92901-08100	5-29	93306-30411	26- 7	94418-18141
13-26	92901-08100	3-10	93310-216A3	26-38	94580-11104
14-18	92901-08100	3- 6	93310-422E6	26-39	94680-11001
19-28	92901-08100	5-25	93311-31515	1-24	94703-00100
20-30	92901-08100	5- 9	93311-41530	14-33	95301-05700
13- 6	92901-08200	6- 2	93315-21813	4-12	95301-06600
13-27	92901-08200	14- 6	93317-22214	17-26	95301-06700
11-16	92901-08600	21- 2	93332-00001	1-23	95301-08600
14-19	92901-08600	21- 1	93332-00008	26-25	95301-08700
13- 8	92901-10100	5- 4	93410-20038	17- 3	95301-10700
19-24	92901-10100	5-16	93410-22039	19-27	95311-08600
20-26	92901-10100	8-12	93410-30012	20-29	95311-08600
14-36	92901-12600	6- 6	93430-08006	18-10	95601-06100
14-13	92901-16100	8- 4	93430-08007	22-10	95601-06100
7- 4	93101-12060	13-24	93430-10015	22-17	95601-06100
8-16	93101-17062	14-24	93430-10015	24- 5	95601-06100
25-15	93102-20009	17-17	93430-10015	17-13	95601-08100

## NUMERICAL INDEX

Ref No.	Part No.	Ref No.	Part No.	Ref No.	Part No.
21- 9	95701-08100				
21-11	95821-08035				
21- 7	95821-08040				
21- 8	95821-08055				
14-26	97301-06012				
23- 9	97301-06012				
23-13	97301-06012				
18- 8	97301-06014				
18-15	97301-06014				
11- 5	97301-06016				
11-11	97301-06016				
17-25	97301-06020				
22- 6	97301-06022				
22-13	97301-06022				
9-12	97301-06025				
9-24	97301-06025				
18- 2	97301-06025				
24- 3	97301-06035				
11-14	97301-08020				
13-25	97301-08020				
11-21	97301-08030				
14-16	97301-08030				
14-17	97301-08035				
17- 7	97311-10016				
5-12	97321-06012				
7- 3	97321-06020				
23-16	97321-06035				
10-24	98501-03008				
15-21	98501-04005				
16-23	98501-04005				
12-11	98501-04008				
10-16	98501-05016				
12- 6	98501-05025				
14-32	98501-05035				
22-20	98503-05015				
9-22	98512-03008				





[www.legends-yamaha-enduros.com](http://www.legends-yamaha-enduros.com)



**YAMAHA MOTOR CO., LTD.**

PRINTED IN JAPAN

First edition Oct., 1977

(2K6-28198-05)