



[www.legends-yamaha-enduros.com](http://www.legends-yamaha-enduros.com)

# DT125F/DT175F ASSEMBLY MANUAL



LIT-11666-01-26

90894-07814

Particularly important information is distinguished in this manual by the following notations:

**NOTE:** . . . . . A **NOTE** provides key information to make procedures easier or clearer.

**CAUTION:** . . . . A **CAUTION** indicates special procedures that must be followed to avoid damage to the machine.

**WARNING:** . . . A **WARNING** indicates special procedures that must be followed to avoid injury to a machine operator or person inspecting or repairing the machine.



[www.legends-yamaha-enduros.com](http://www.legends-yamaha-enduros.com)

**YAMAHA DT125F/DT175F  
ASSEMBLY MANUAL  
1ST EDITION, MAY 1978  
OVERSEAS SERVICE DEPARTMENT  
YAMAHA MOTOR CO., LTD.  
IWATA, JAPAN  
PRINTED IN JAPAN  
LIT-11666-01-26**

## FOREWORD

The Assembly Manual contains the information required to unpack and assemble Yamaha motorcycles correctly prior to delivery to the customer. Proper motorcycle set-up assembly and pre-delivery service demands a basic knowledge of motorcycle service procedures, familiarity with Yamaha products, and correct tools. This assembly manual should be used with the Dealer Set-up and Pre-delivery Check List, Service Manual, Supplementary Service Manual, and Parts List for this model.

Proper set-up, assembly and pre-delivery service is necessary for the following reasons:

To assure the customer of the long life and performance he expects from his new Yamaha motorcycle.

To minimize service problems during the break-in period.

To conform with federal new vehicle regulations.

## NOTICE

The service specifications given in this manual are based on the model as manufactured. Modifications and significant changes in specifications and/or procedures will be forwarded to all Authorized Yamaha Dealers.

The procedures below are described in the order that the mechanic should follow. Special care should be taken to ensure that the procedures are carried out correctly and completely. Failure to do so can result in poor performance, excessive emissions, and possible harm to the machine and/or rider.

The DEALER SET-UP AND PRE-DELIVERY CHECK LIST has been designed to be used with this Assembly Manual. As each procedure is satisfactorily completed, the mechanic should mark the appropriate space on the sheet. After it has been signed by the assembling mechanic, the servicing mechanic, and the customer, a copy of the Check List should be given to the customer and another copy retained in the dealership files. If the Service Manager test rides the machine before delivery, he should also sign the Check List.

### — IMPORTANT: —

**This Assembly Manual contains important information regarding procedures designed to ensure proper emissions control functioning and service. Please read this material carefully and carry out the prescribed procedures properly!**

### — CONCERNING CRATE DAMAGE: —

**Follow the instructions in the Dealer Warranty Handbook, Procedure Section.**

## PREPARATION

To assemble the machine correctly, the following service tools, supplies and working space are required.

## UNPACKING

### Note on transportation

Use care not to butt the machine packed in the crate against a hard object or give it a heavy shock during transportation or in the service shop.

### Procedure for unpacking

To remove the machine and parts packed in the cardboard crate, cut the vinyl bands around the box using a cutter or scissors. Next, remove the exterior carton by lifting it straight up.

Remove the foam tray, front wheel and seat. Next, remove the nails from each corner of crate, and remove the struts.

Remove the front fender and double seat.

### Check list

Set position	Q'ty	Part name
A	1	Styrofoam case
B	1	Front wheel
C	1	Front fender
D	1	Seat

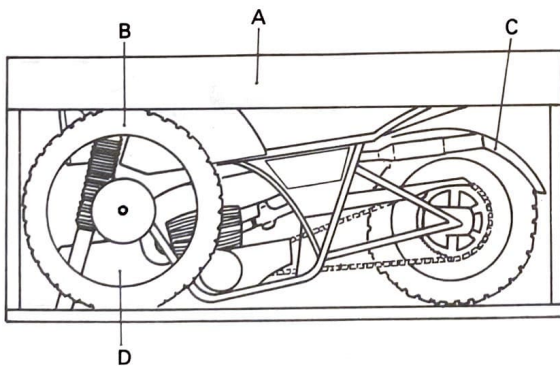

### Details of parts on styrofoam "A"

No.	Part name	Q'ty
1	Handle bar assembly	1

No.	Part name	Q'ty
2	Meter panel assembly	1
3	Taillight assembly	1
4	Front brake shoe plate	1
5	Front flasher light	2
6	Rear flasher light	2
7	License plate	1
8	Speedometer cable	1



### Parts list: Carton box

No.	Part name	Q'ty
1	Owner's manual	1
2	Rear view mirror	1
3	Tool kit	1
4	Fuel tank breather pipe	1
5	Battery breather pipe	1
6	Wire holder (1)	1
7	Wire holder (2)	1
8	Flasher stay	2
9	Vinyl bag "A"	1

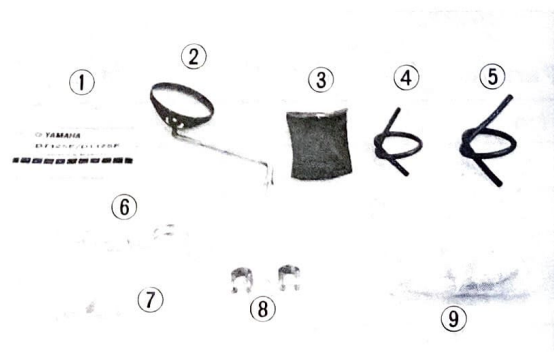

**Parts list: Vinyl bag "A"**

No.	Part name	Q'ty	Remarks
1	Bolt with washer [6ø l = 25 mm (1.0 in)]	1	Wire holder
2	Cotter pin	1	Front wheel
3	Torsion spring	2	Footrest
4	Washer	2	
5	Cotter pin	2	
6	Battery positive lead wire	1	Battery
7	Battery negative lead wire	1	
8	Nut	2	Front flasher
9	Nut	2	Rear flasher
10	Spring washer	2	
11	Bolt with washer [6ø l = 16 mm (0.6 in)]	2	License plate
12	Nut	2	
13	Spring washer	2	
14	Reflector	1	

No.	Part name	Q'ty	Remarks
15	Spring washer	1	Reflector
16	Plate washer	1	
17	Nut	1	
18	Bolt with washer [6ø l = 25 mm (1.0 in)]	1	Taillight assembly (Front part)
19	Collar	1	
20	Damper	1	
21	Damper	1	
22	Plate washer	1	
23	Nut	1	
24	Bolt [6ø l = 35 mm (1.4 in)]	2	Taillight assembly (Rear part)
25	Plate washer	2	
26	Collar	2	
27	Damper	1	
28	Damper	2	
29	Spring washer	2	
30	Nut	2	

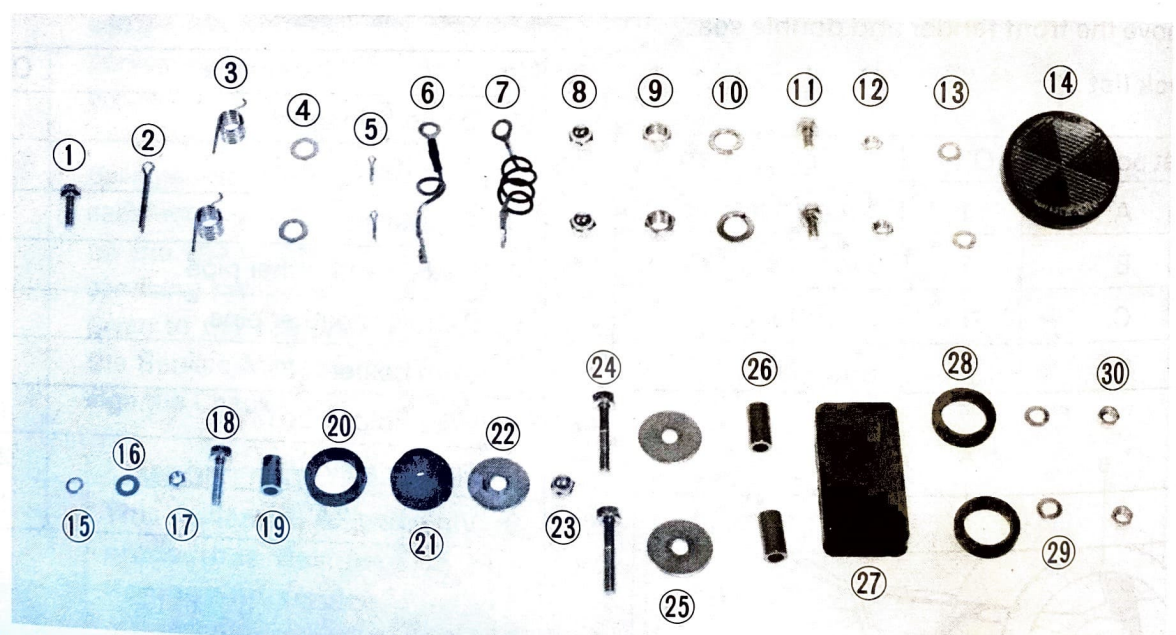

**Parts list: Vinyl bag "B"**

No.	Part name	Q'ty	Remarks
1	Collar	1	Front wheel
2	Footrest (1)	1	Footrest
3	Footrest (2)	1	
4	Clevis pin	2	
5	Bolt with washer [6ø l = 30 mm (1.2 in)]	2	Speedometer assembly

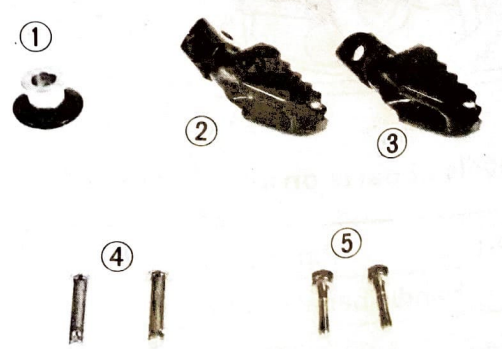

## TORQUE SPECIFICATIONS

The list at right covers those stud/bolt sized with standard I.S.O. pitch threads. Torque specifications for components with thread pitches other than standard are given within the applicable chapter.

Torque specifications call for dry, clean threads. Components such as the cylinder or cylinder head should be at room temperature prior to torquing. A cylinder head or any other item with several fasteners should be torqued down in a crisscross pattern in successive stages until torque specification is reached. The method is similar to installing an automobile wheel and will avoid warping the component.

### Standard Torque Setting

A	B	TORQUE SPECIFICATION		
		m-kg	ft-lb	in-lb
10 mm	6 mm	1.0	7.2	85
12 mm	8 mm	2.0	15	175
14 mm	10 mm	4.0	29	350
17 mm	12 mm	4.5	33	400
19 mm	14 mm	5.0	36	440
22 mm	16 mm	6.0	43	520
24 mm	18 mm	7.0	50	610
27 mm	20 mm	8.0	58	700
Spark plug		2.5	18	230

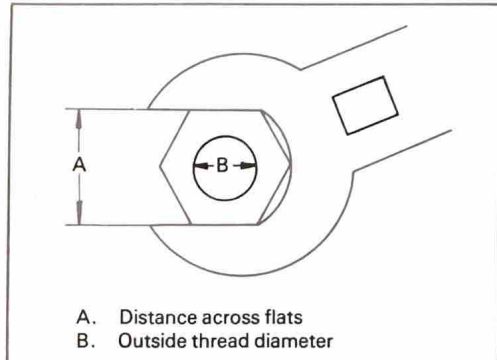

[www.legends-yamaha-enduros.com](http://www.legends-yamaha-enduros.com)

### Tightening torque

MODEL	DT125F/DT175F
<b>Engine:</b>	
Cylinder head	2.5 m-kg (18 ft-lb)
Spark plug	2.5 m-kg (18 ft-lb)
Cylinder	4.0 m-kg (29 ft-lb)
Primary drive gear	6.0 m-kg (43 ft-lb)
Clutch boss	5.0 m-kg (36 ft-lb)
Clutch spring	0.5 m-kg (3.6ft-lb)
Drive sprocket	5.5 m-kg (40 ft-lb)
Kick crank	1.5 m-kg (11 ft-lb)
Reed valve	0.1 m-kg (0.7ft-lb)
Rotor nut	5.5 m-kg (40 ft-lb)
<b>Chassis:</b>	
Engine mount front upper	2.5 m-kg (18 ft-lb)
rear upper	2.5 m-kg (18 ft-lb)
rear lower	4.0 m-kg (29 ft-lb)
Pivot shaft nut	4.0 m-kg (29 ft-lb)
Front fork damper unit (cylinder comp.)	2.0 m-kg (15 ft-lb)
Rear shock absorber (frame)	2.5 m-kg (18 ft-lb)
Handle crown pinch bolt	2.5 m-kg (18 ft-lb)
fitting bolt	6.0 m-kg (43 ft-lb)
upper bracket holder	1.5 m-kg (11 ft-lb)
Inner tube	3.5 m-kg (25 ft-lb)
Under bracket pinch bolt	2.0 m-kg (15 ft-lb)
Front axle nut	4.8 m-kg (35 ft-lb)
Rear axle nut	10.0m-kg (72 ft-lb)
Driven sprocket bolt	4.0m-kg (29 ft-lb)



# YAMAHA MOTORCYCLE

## DEALER SET-UP AND PRE-DELIVERY CHECK LIST

I hereby certify that prior to delivery to the retail purchaser, assembly and pre-delivery service was performed on the motorcycle listed below in accordance with the following check list and in compliance with established procedures prescribed by Yamaha.

MODEL \_\_\_\_\_ FRAME NO. \_\_\_\_\_ ENGINE NO. \_\_\_\_\_

Assemble according to the assembly manual and any technical bulletin information that applies to this particular model. Pay special attention to the following items.

### SET-UP ASSEMBLY

- FRONT FORK PINCH BOLTS — Torque to specification
- FRONT WHEEL AND AXLE — Torque axle and axle holder to specification
- FRONT AXLE COTTER PIN — Install
- HANDLEBAR HOLDER (spring tension type) — Position die marks on holder to front, torque to specifications
- HANDLEBAR HOLDER (standard) — tighten bolts evenly, in a crisscross pattern until proper torque is attained
- WIRING CONNECTORS — Check for color code and proper connection
- FRONT BRAKE CABLE (drum brake) — Install
- MASTER CYLINDER (disc brake) — Install
- INSTRUMENTS — Install instruments and route the cables as shown on cable routing diagrams
- TAILLIGHT — Install on applicable models
- BRAKE PEDAL — Install per assembly manual
- ALL NUTS AND BOLTS — Check tightness and proper torque
- CONTROLS — Check for proper operation
- KEYS — Check all locks for proper operation

SET-UP BY \_\_\_\_\_ DATE \_\_\_\_\_

### PRE-DELIVERY SERVICE

- ALL NUTS AND BOLTS — Check for torque and tightness, especially  Engine mounting bolts and/or nuts  Steering head,  Rear swing arm pivot shaft  Axles
- HYDRAULIC DISC BRAKES (front & rear) — Check master cylinder fluid level, bleed systems, check and adjust free play, and check operation
- TWIN FRONT DISC BRAKE — Check clearances between caliper brackets and disc, reposition if necessary
- TIRES-Adj. pressure: front \_\_\_\_\_ rear \_\_\_\_\_
- SPOKES — Check tightness
- FUEL FILTER SCREEN AND FUEL LINE — Clean and check for connection lightness
- CARBURETOR — Drain stale fuel from lines and float bowls
- CARBURETOR — Tighten caps and mounting bolts
- CARBURETOR — Adjust starter lever freeplay (if applicable)
- CARBURETOR — Adjust throttle cable freeplay
- MECHANICAL BRAKES — Check and adjust freeplay, check operation
- CLUTCH — Check and adjust freeplay
- COMPRESSION RELEASE CABLE (if applicable) — Check and adjust freeplay
- ENGINE/TRANSMISSION OIL — Drain and refill, qty \_\_\_\_\_ type \_\_\_\_\_
- SHAFT DRIVE GEAR OIL LEVELS — Check oil levels, add as necessary
- BATTERY — Charge until specific gravity reaches 1.26 ~ 1.28 according to Service Manual procedure. Install and route breather tube checking for restrictions
- ELECTRICAL COMPONENTS — Check for proper operation of: Headlamp ( Hi,  Lo)  Turn signals, (Stoplight  front,  rear),  Taillight,  Indicator lights,  Instrument light,  Horn
- DRIVE CHAIN — Lubricate, if necessary, and adjust, align rear wheel
- FOAM AIR FILTER — Service

### 2-STROKE ONLY:

- AUTOLUBE TANK — Fill tank, oil type \_\_\_\_\_ Check breather tube routing
- AUTOLUBE PUMP — Bleed air from pump and all lines
- AUTOLUBE PUMP — Adjust cable and check minimum stroke
- AUTOLUBE OIL DELIVERY — Check oil delivery to cylinders and for leaks

### EXHAUST EMISSIONS CONTROL

The following items are related to emissions control. Check and adjust if necessary in accordance with the Yamaha published service manual and technical bulletins for this particular model.

- CAM CHAIN TENSIONER (if applicable) — Adjust
- VALVES — Clearance: Intake \_\_\_\_\_ mm, Exhaust \_\_\_\_\_ mm
- SPARK PLUG GAP — Check \_\_\_\_\_ mm
- IGNITION POINTS (if applicable) — Check gap \_\_\_\_\_ mm
- IGNITION TIMING Check:  Idle  Advance
- CARBURETOR — Check synchronization (if applicable)
- IDLE SPEED Check; \_\_\_\_\_ r/min

- TEST RIDE — Check performance, handling and operation, adjust mirrors
- OPTIONAL SERVICE MANAGER TEST RIDE \_\_\_\_\_

### CUSTOMER CHECK LIST

- RECEIVED TOOL KIT (if applicable)
- RECEIVED OWNERS WARRANTY GUIDE
- RECEIVED OWNERS MANUAL
- RECEIVED SERVICE INSTRUCTIONS

### Service manager Signature

I have performed this pre-delivery adjustments are specified in the assembly manual, service specifications and any technical bulletins applying to this model.

CUSTOMER \_\_\_\_\_ DATE \_\_\_\_\_

\_\_\_\_\_  
DATE \_\_\_\_\_

[www.legends-yamaha-enduros.com](http://www.legends-yamaha-enduros.com)

DEALERSHIP NAME \_\_\_\_\_  
 DEALER NO. \_\_\_\_\_  
 ADDRESS \_\_\_\_\_  
 CITY/STATE/ZIP CODE \_\_\_\_\_

## SET-UP PROCEDURES

1. To install the front fender and front wheel, place a proper-size wooden box or a wooden block under the engine to keep the front of the machine raised off the floor. Take care so that the machine does not fall over.
2. Insert the front fender between the front fork legs, and secure the front fender using the specified number of bolts, spring washers, fender collars, plain washers and dampers.

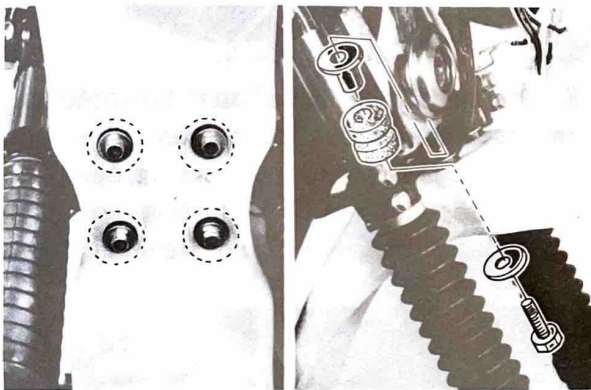

Tightening torque: 0.45 m·kg (3.25 ft·lb)

### NOTE:

- a. The front fender should be installed with the arrow mark in the right facing forward.
- b. Bolts, spring washers, plain washers, dampers and fender collars are fitted to under bracket.

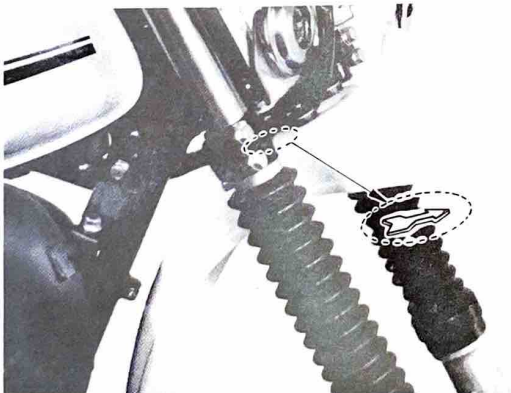

3. Apply a light coat of grease to the speedometer drive gear and oil seal.

### CAUTION:

Take care not to put grease on the brake linings or inner surface of the brake drum. If you do so, clean using a rag dampened with a solvent. Foreign material on braking surface can cause impaired braking action.

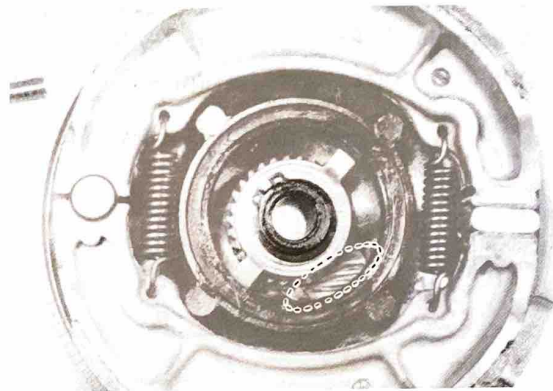

4. Remove the front wheel axle nut and plain washer, and loosen the nuts securing the axle holder. Then remove the wheel axle and distance collar.

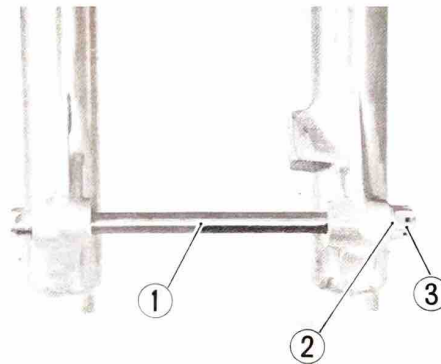

1. Wheel axle 2. Plain washer 3. Axle nut

5. Install the brake shoe plate assembly in the front wheel hub.
  - a. Clean the inner surface of the front wheel hub with a clean cloth.



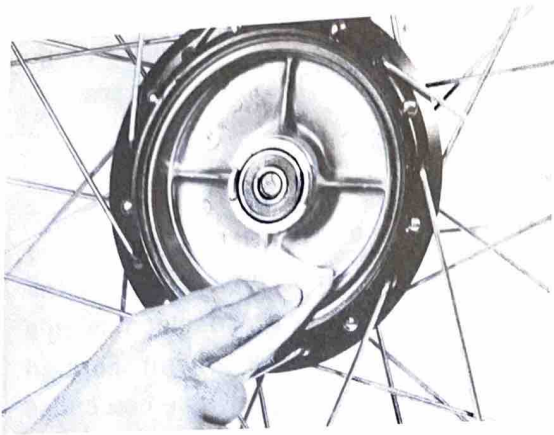

b. Make sure the brake shoes and springs are correctly installed in the shoe plate assembly. If any one of them is out of position, correct per the figure.

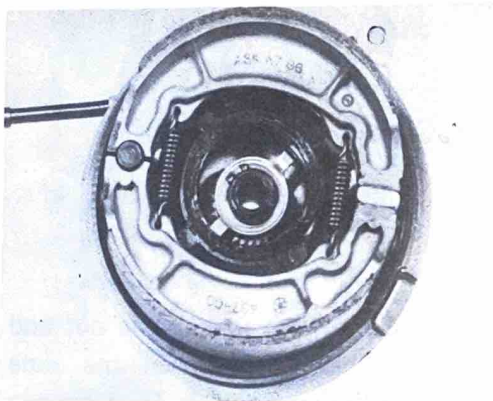

c. Install the brake shoe plate assembly in the wheel hub.

**NOTE:**

Make sure the two legs in the wheel hub align with the two slots in the speedometer clutch assembly.

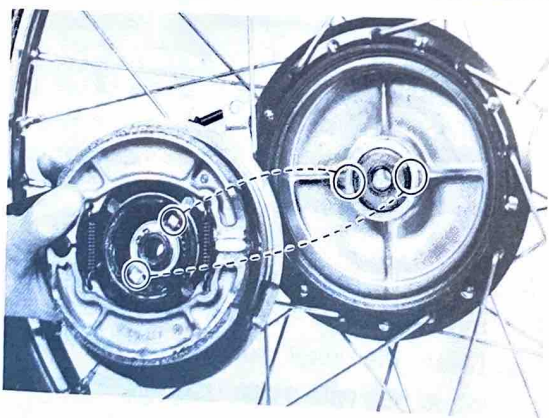

6. Install the wheel axle collar in the wheel hub on the right side of the front wheel.

**NOTE:**

To avoid damaging the oil seal lip, apply a light coat of lithium base grease to the oil seal lip and collar. If the collar has dirt, clean with a rag.

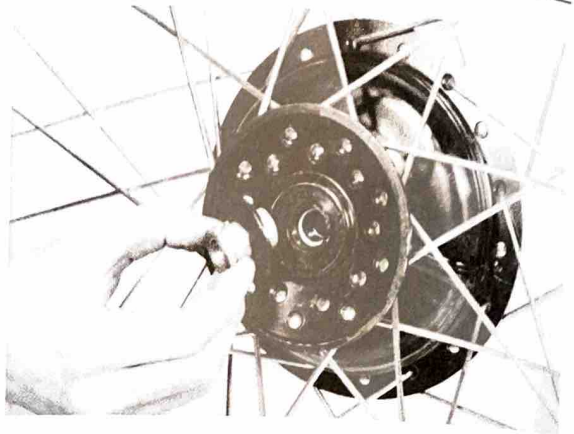

7. Install the front wheel on the front forks.  
a. Insert the front wheel between the front fork legs so that the stopper (projection) on the front fork end has correctly engaged the slot in the brake shoe plate.

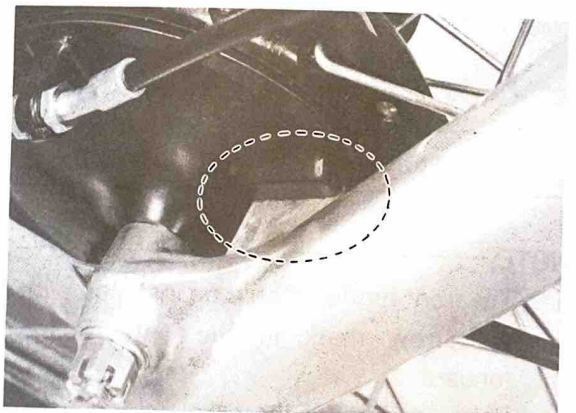

b. Install the distance collar on the wheel axle. Then, insert the axle, and install the axle nut and plain washer.

c. Torque the axle nut to specification.

Tightening torque: 4.8 m·kg (35 ft·lb)

- d. Lock the nut with the cotter pin. The pin should be inserted downward, and the pin ends should be bent.

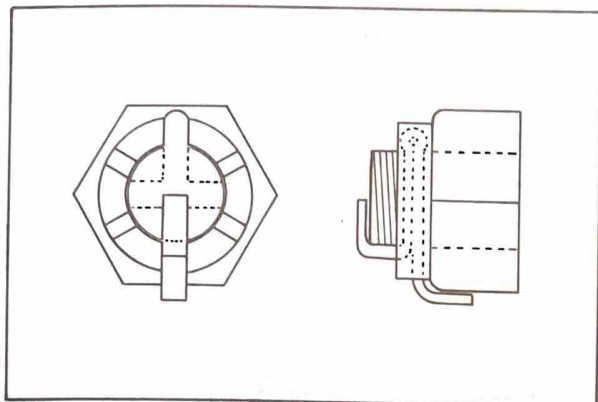

8. Install the wire holder to the left side projection part of front fork outer tube using damper and bolt with plain washer.

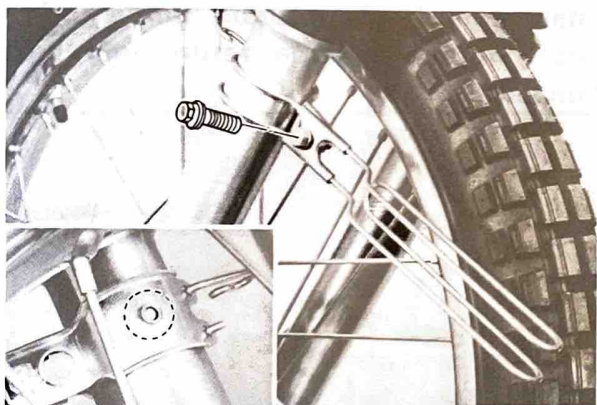

9. Install the speedometer and front brake cables to the front wheel hub.

- a. Connect the speedometer cable to the front wheel hub gear unit. Insert the cable end into the gear unit, fit the circlip in the groove on the wheel hub side, and lock the cable. (The circlip is already attached to the cable.)

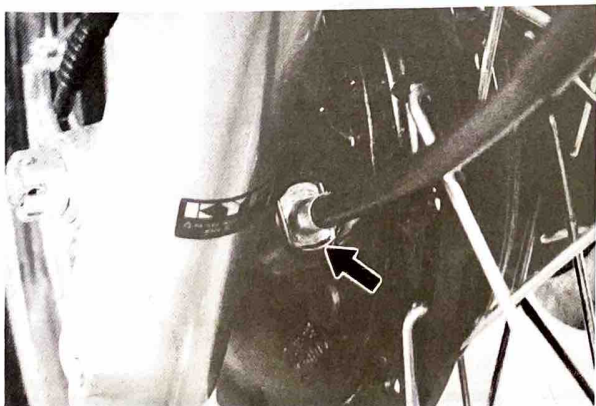

- b. Insert the front brake wire end to the camshaft lever and hook the outer cable end onto the adjuster.

\* For detailed cable routing refer to "CABLE ROUTING DIAGRAM"

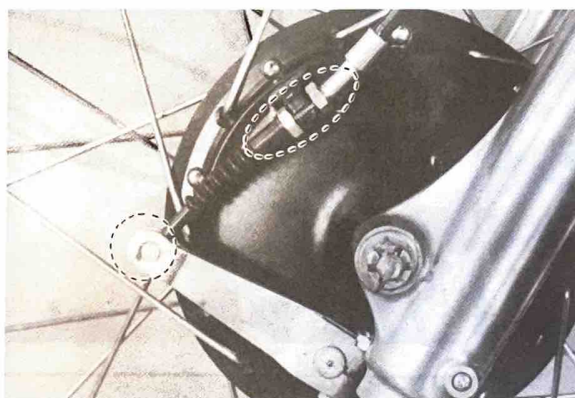
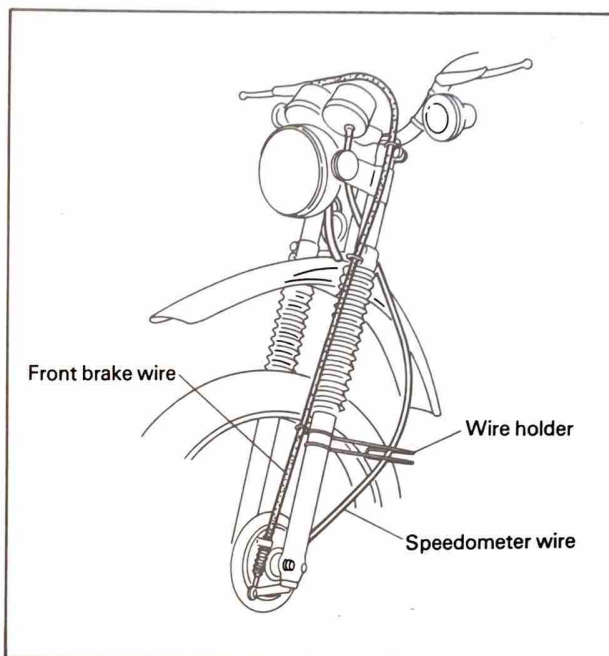

10. Remove the bolt from the bottom of the headlight body. Insert a slotted head screw driver between the headlight body and the headlight assembly. Pry out the lens assembly.

**NOTE:**

During the operation, care should be taken not to scratch the headlight body.

Also take care so that the anchor screw is not lost.

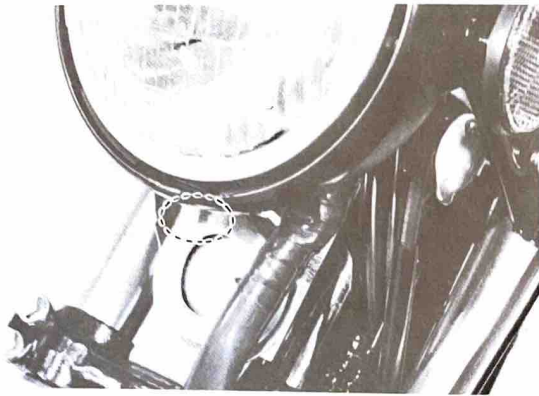

**CAUTION:**  
**First tighten the bolts on the front side of the handlebar holder and tighten the bolts on the rear side.**

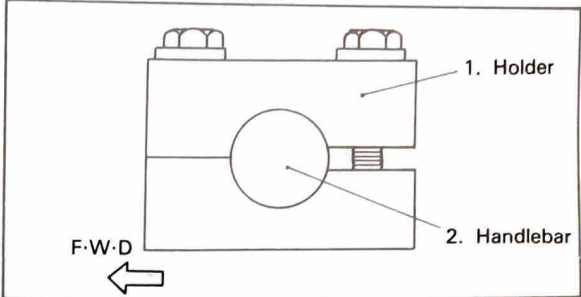

11. Handlebar installation
- Remove the four hexagon bolts, and remove the two handlebar holders.
  - Insert all the lead wires coming from the handle switches into the headlight body.
  - Install the handlebar using the two removed upper holders, four hexagon bolts.

Tightening torque: 1.5 m·kg (11 ft·lb)

12. Loosen the two screws securing the throttle housing assembly. Grease the right end of handlebar and the throttle grip housing, and install the throttle grip.

**CAUTION:**  
**Make certain throttle grip rotates on handlebar freely without binding. If not, normal throttle return will be impaired.**

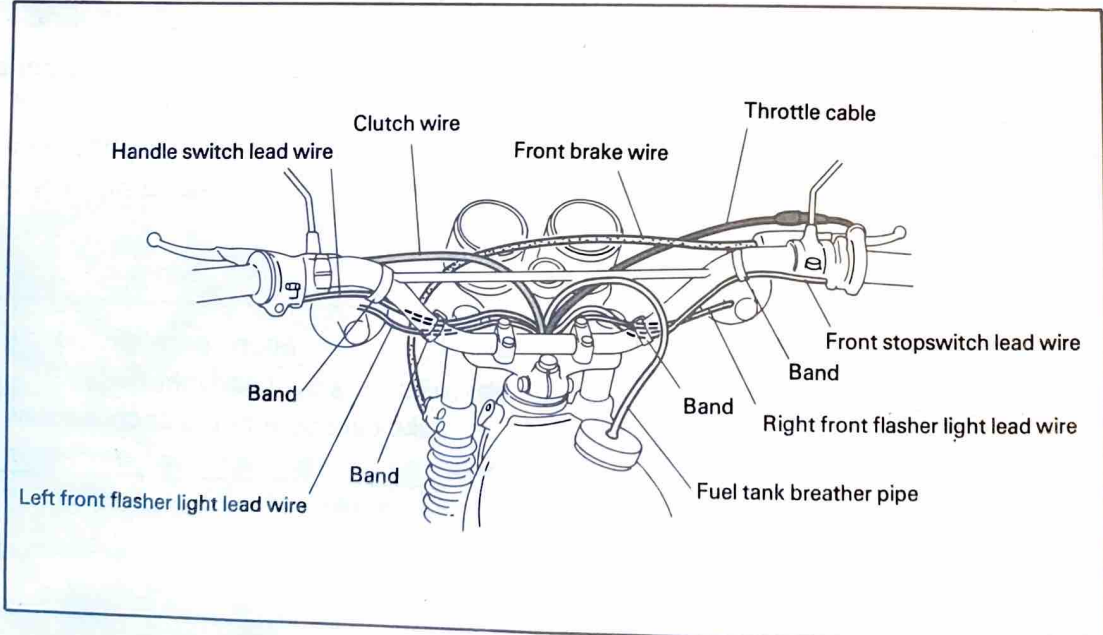
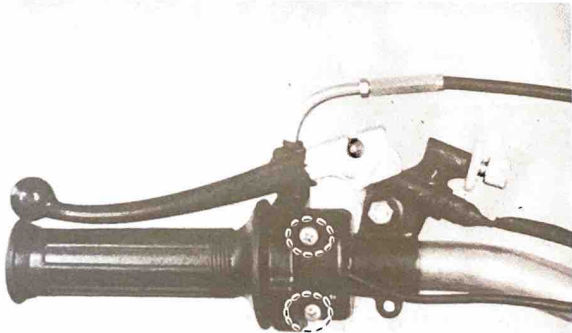
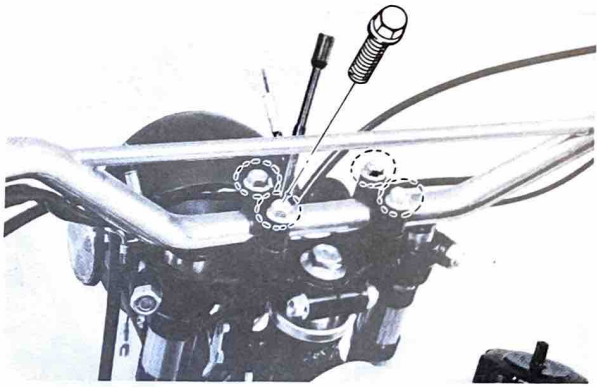

13. Install the meter bracket on the handle crown using bolts with plain and spring washer.

**NOTE:**

Before securing the meter bracket, all wires should be threaded through the headlight body. Take care not to kink wires by pressure.

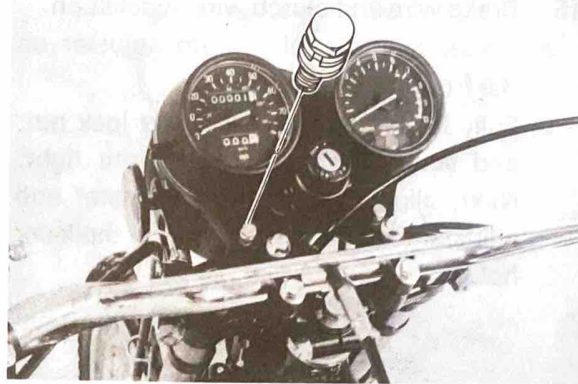

14. Connect the speedometer cable and tachometer cable to the speedometer and tachometer.

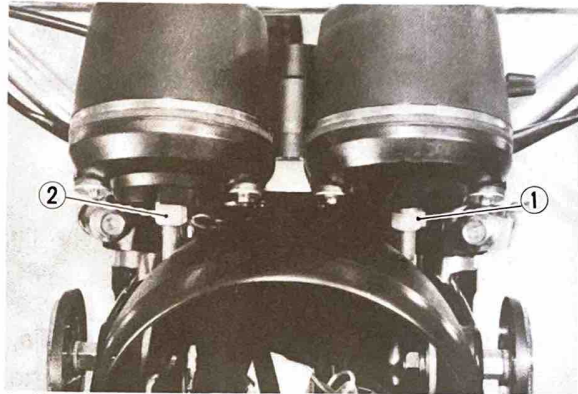

1. Speedometer cable 2. Tachometer cable

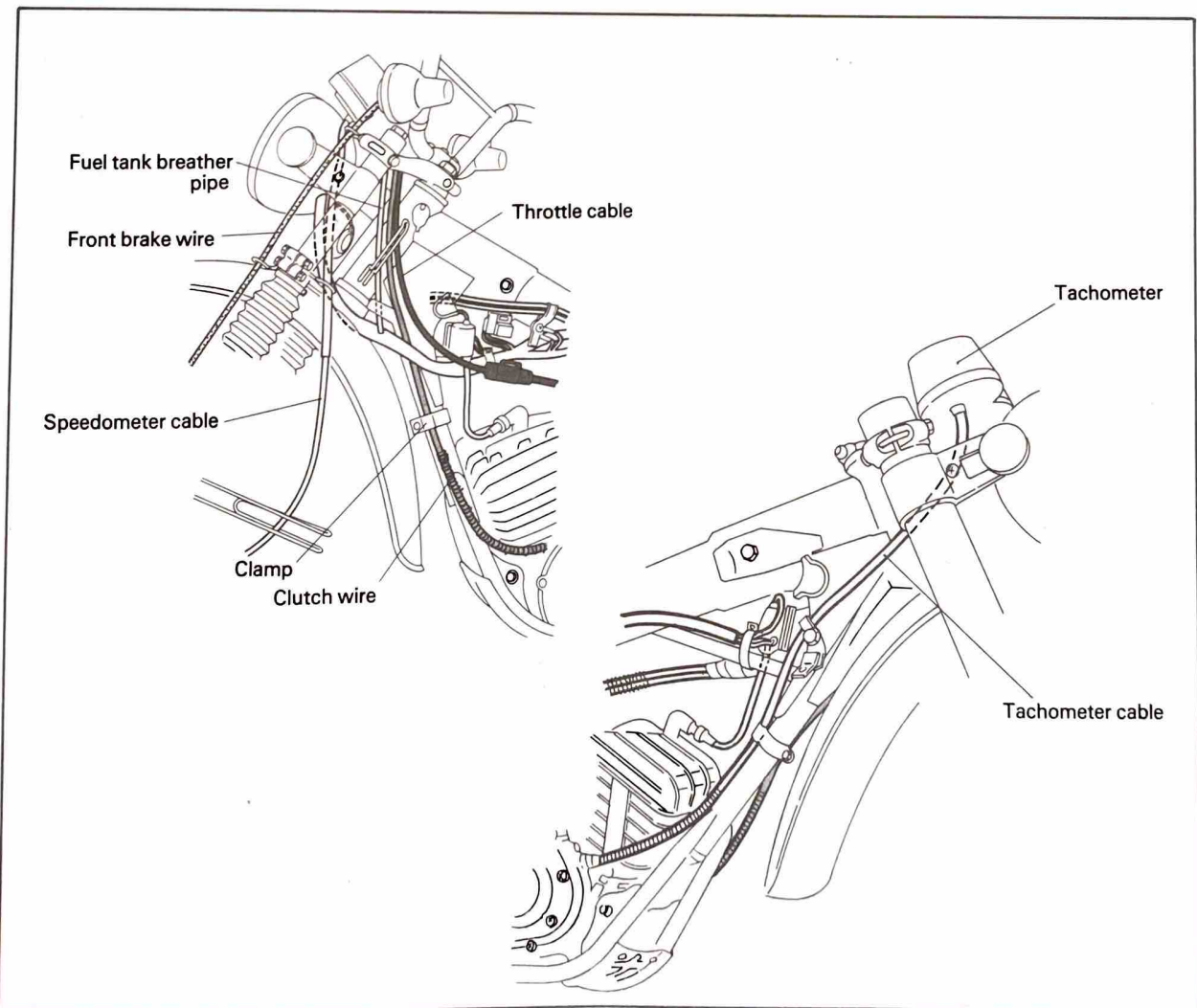

15. Brake wire and clutch wire installation.
  - a. Screw in the cable length adjuster on the front brake shoe plate.
  - b. Fully loosen the lever adjuster lock nut, and screw in the adjuster until tight. Next, align the slit in the adjuster and adjuster lock nut with the slit in the lever holder.

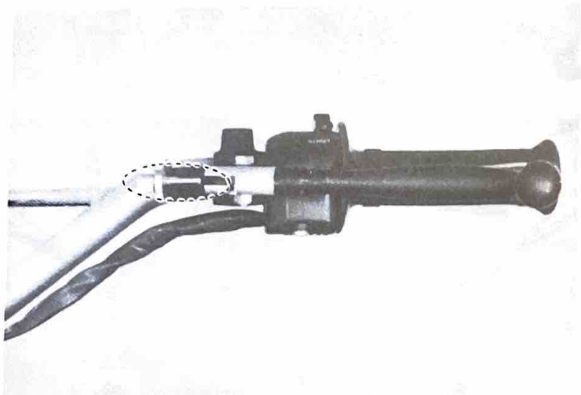

- c. Insert the wire end into the lever hole, and hook the outer cable end onto the adjuster lock nut, then squeeze the lever. Next, while pulling the outer cable in the direction opposite to the lever, release the lever quickly. While releasing it, seat the outer cable into the adjuster.

**CAUTION:**

Proper cable and wire routing is essential to insure safe vehicle operation. For details of the cable routing, refer to "CABLE ROUTING DIAGRAM".

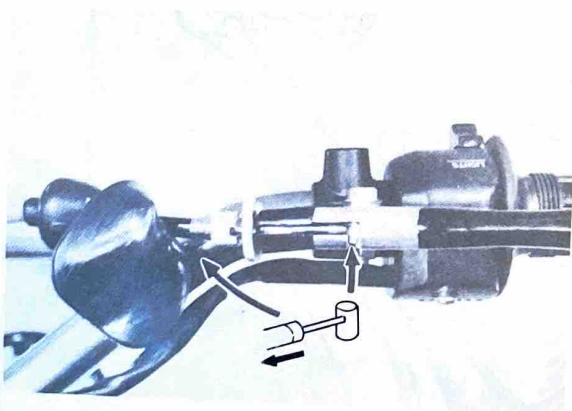

- d. Install the lever covers on clutch and brake wires.

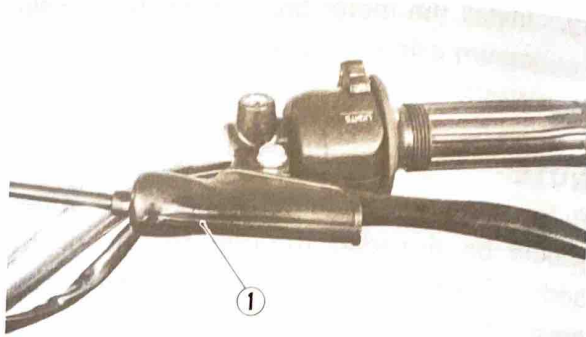

1. Lever cover

16. Front flasher light installation

- a. Install both right and left front flasher lights to flasher stays of handlebar.
- b. Install the flasher lights to stays using nuts.

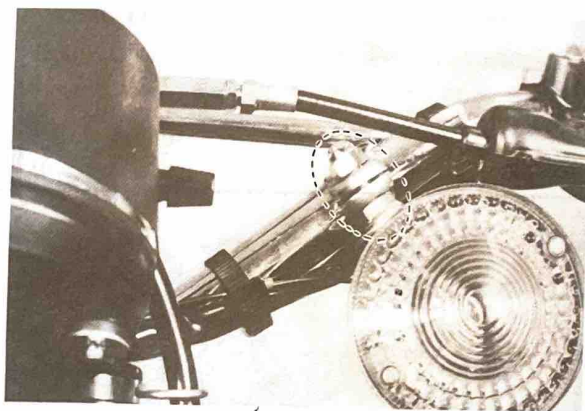

- c. Hold the light lead wire to the handlebar with a rubber band, and insert the lead wire end into the headlight body.

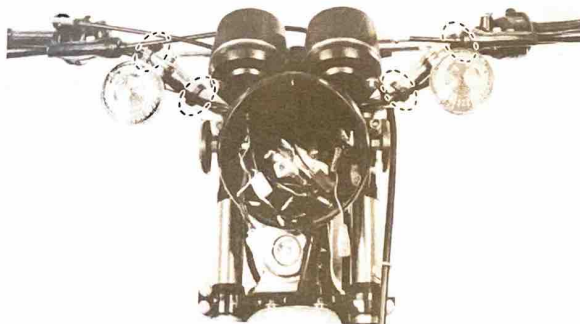

17. Connect all lead wires inside the headlight body. The wires of identical colors should be connected.

**NOTE:**

Flasher light lead wires are excluded.

Right flasher light lead wire

⇔ Dark green lead wire

Left flasher light lead wire

⇔ Dark brown lead wire

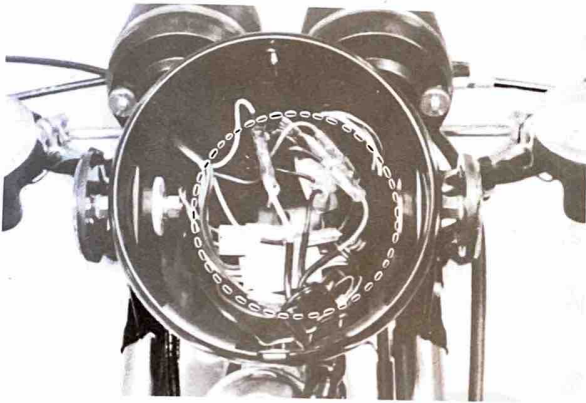

18. When installing the headlight lens assembly, care should be used so that wires are not pinched. Secure the headlight assembly in place with the bolt.



19. Install the rear view mirror on the clutch lever holder (lefthand side), and tighten the lock nut.

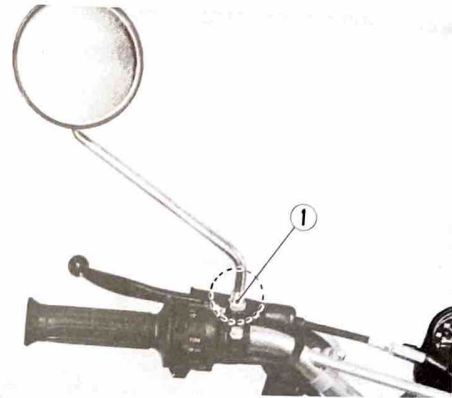

1. Lock nut

20. Fuel tank breather pipe installation  
Pass through between the handle crown and meter bracket and let it hang down.

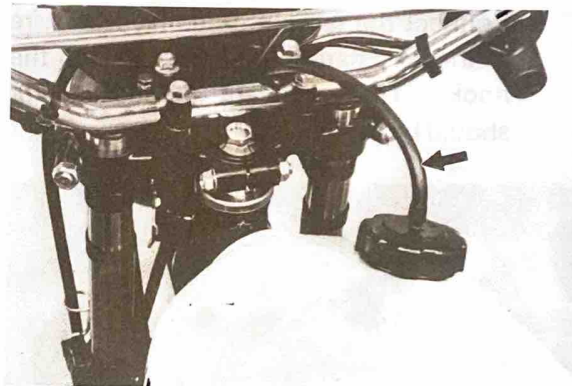

21. Footrest installation  
Install the footrest to both right and left sides of the lower part of the frame.

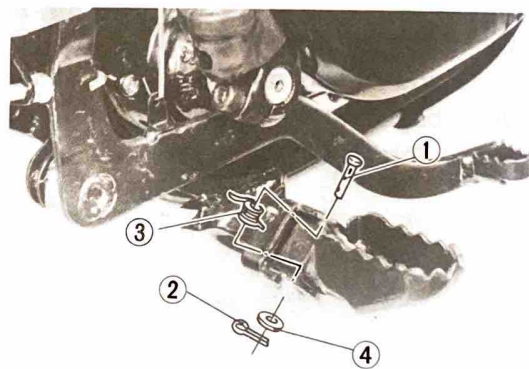

1. Clevis pin 2. Cotter pin 3. Torsion spring  
4. Plate washer

[www.legends-yamaha-enduros.com](http://www.legends-yamaha-enduros.com)

**22. Taillight assembly installation**

- a. Install the dampers and collars on the taillight bracket.

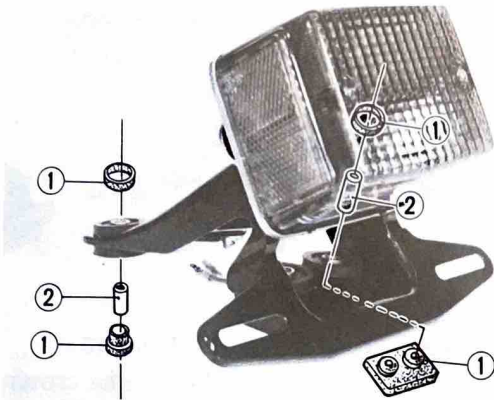

1. Damper 2. Collar

- b. Connect the taillight assembly lead wire to the wire harness, and lock it with the hook. (The wires of identical color should be connected.)

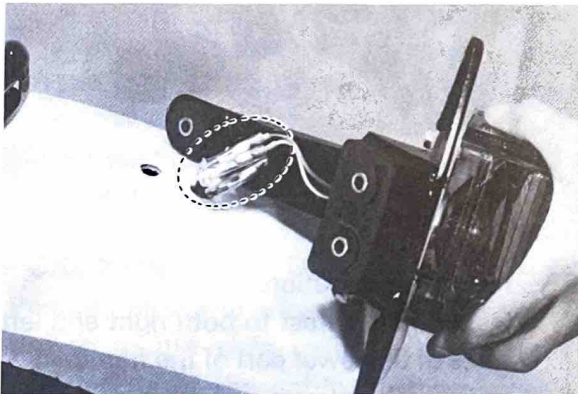

- c. Using the plate washer, fender mount bolt, and crown nut contained in the vinyl bag secure the front part of the taillight bracket to the rear fender.

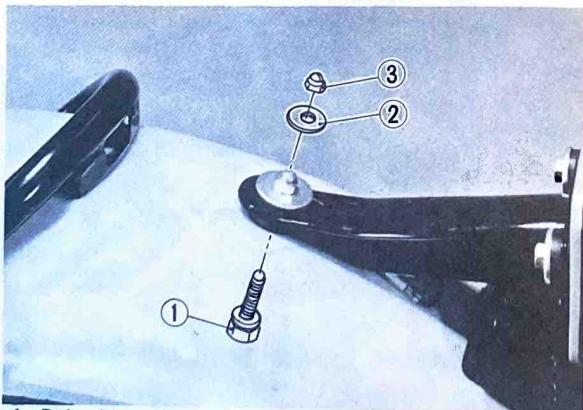

1. Bolt with washer 2. Plate washer 3. Crown nut

- d. Using the plate washers, nuts and bolts contained in the vinyl bag secure the rear part of the taillight bracket to the fender.

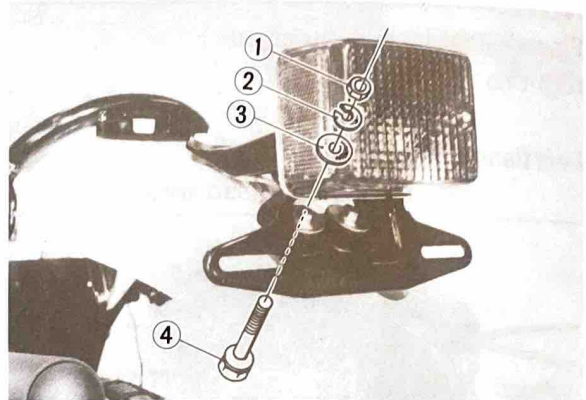

1. Nut 2. Spring washer 3. Plate washer 4. Bolt with washer

**23. License plate installation**

- Install the license plate to the taillight assembly as shown in the photo.

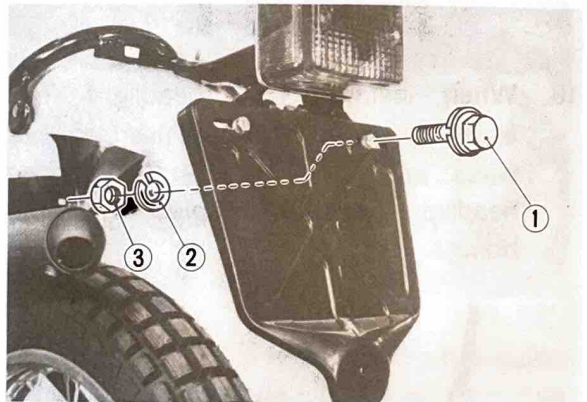

1. Bolt with washer 2. Spring washer 3. Nut

**24. Rear reflector installation**

- Install the rear reflector to the license rear plate.

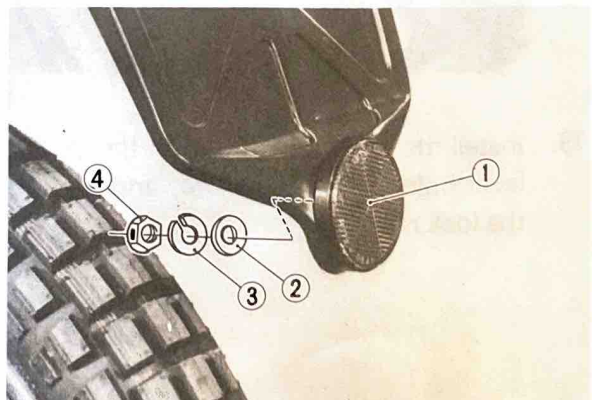

1. Reflector 2. Plate washer 3. Spring washer 4. Nut

25. Rear flasher light installation

- a. Install the lead wire, with dark brown on the left side. Next, install the other flasher light (dark green lead wire) on the right side.
- b. Install the left and right flasher lights using the spring washer and nut.

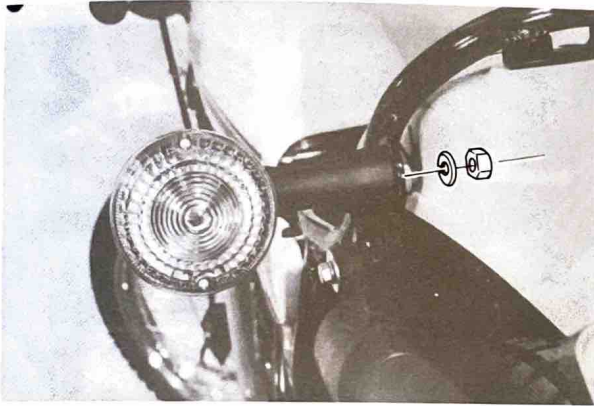

26. Connect the right flasher light lead wire to green lead wire, and left flasher light lead wire to brown lead wire.

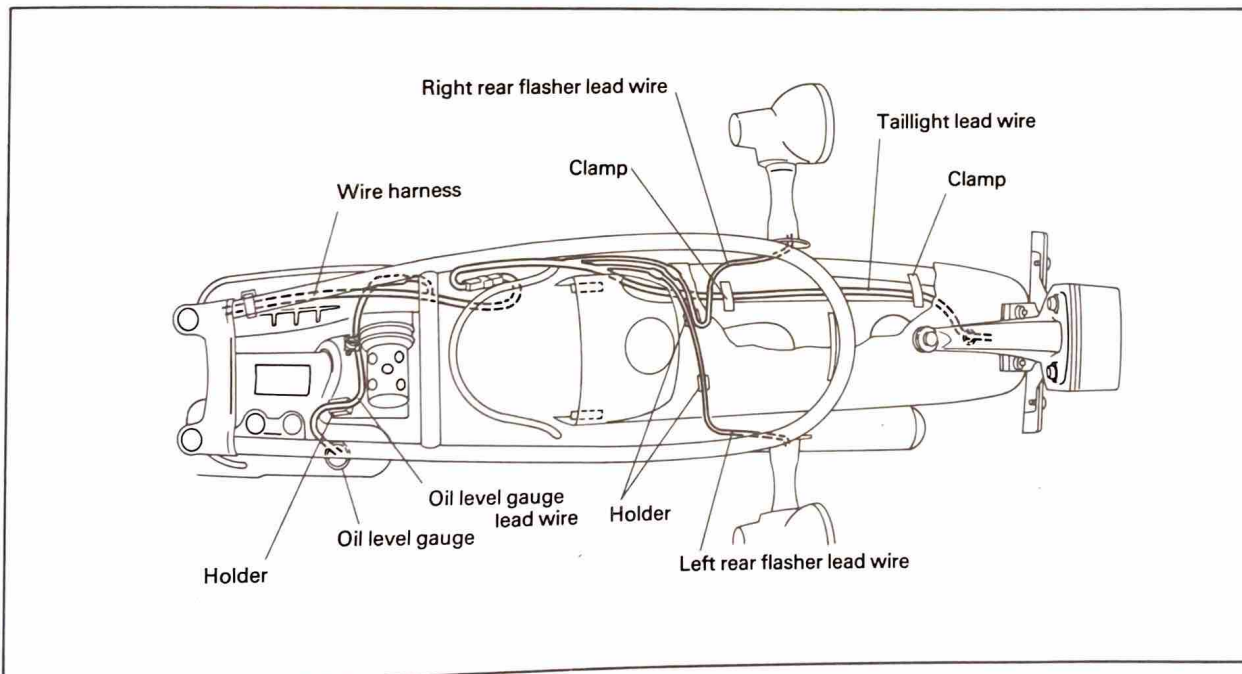
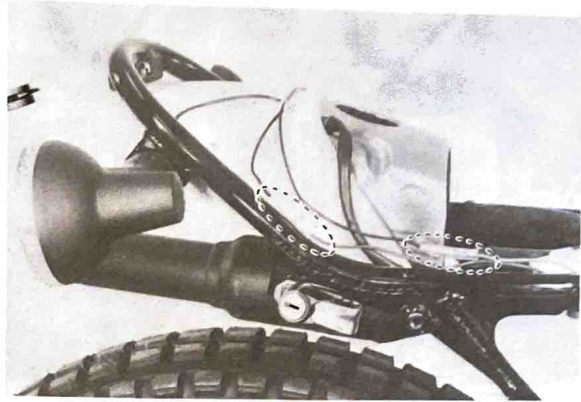

27. Seat installation

Insert the hook on the end of the seat into the frame, and secure both sides of the seat with plain washers and bolts.

Tightening torque: 1.0 m·kg (7.2 ft·lb)





28. Install the service tool assembly as photo.

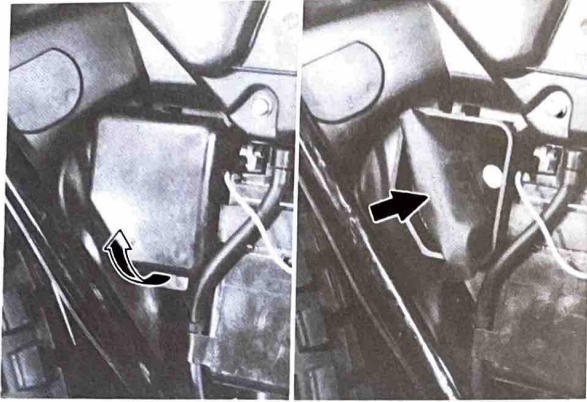

### ADJUSTMENTS Pre-delivery Service

The following adjustments must be made before delivery of the motorcycle to a customer. Use the CHECK LIST to mark off each operation when it is complete.

#### Brake adjustment

##### 1. Front brake adjustment

Front brake cable freeplay can be adjusted to suit rider preference, but a minimum freeplay of 5 ~ 8 mm (0.2 ~ 0.3 in) should be maintained.

Freeplay can be adjusted at handlebar lever or brake shoe plate.

- a. Loosen the adjuster lock nut (2).
- b. Turn the adjuster (1) in or out until adjustment is suitable.
- c. Tighten the adjuster lock nut (2).

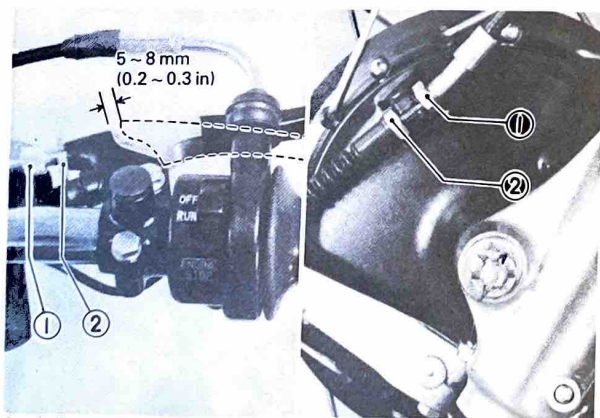

1. Adjuster 2. Lock nut

##### 2. Rear brake adjustment

- a. Adjust rear brake pedal play to suit rider, providing a minimum of 20 mm (0.8 in) freeplay. Adjust as follows:
- b. Turn the adjuster on the rear brake ferrule in or out until brake pedal freeplay is suitable (20 ~ 30 mm (0.8 ~ 1.1 in) freeplay).

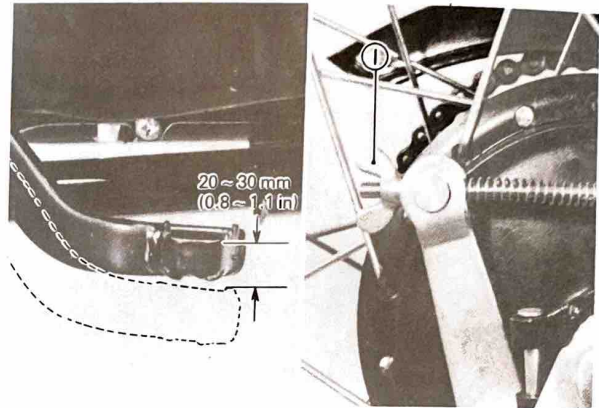

1. Adjuster

#### Clutch lever freeplay adjustment

1. Loosen the adjuster lock nut on the lever holder then turn the adjuster in. Tighten lock nut.
2. Loosen the cable length adjuster lock nut.
3. Adjust the lever freeplay by turning the cable length adjuster in or out.

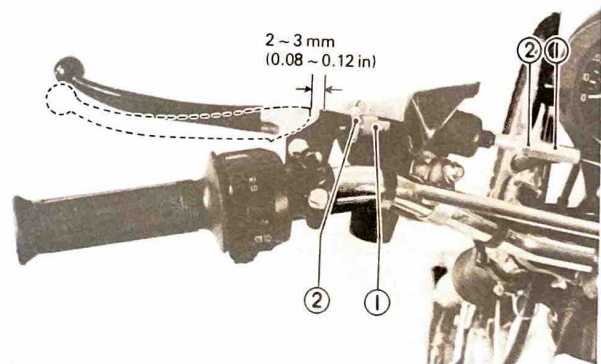

1. Adjuster 2. Lock nut

## Throttle cable adjustment

### Throttle freeplay adjustment

Check play in turning direction of throttle grip. Play should be 3 ~ 5 mm (0.12 ~ 0.20 in) at grip flange. Loosen the lock nut and turn the wire adjuster to make the necessary adjustment. After adjusting, be sure to tighten the lock nut properly.

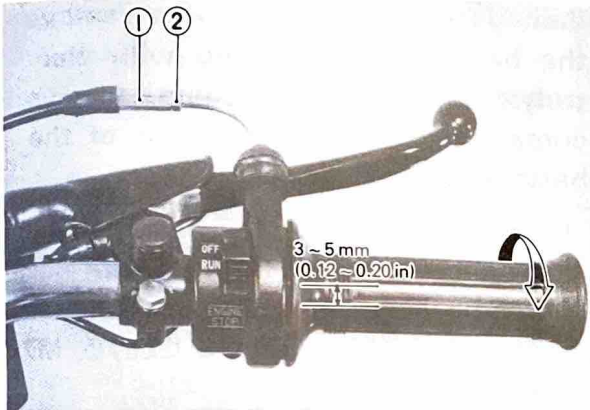

1. Adjuster 2. Lock nut

## Drive chain adjustment

### 1. Tension check

Inspect the drive chain with both tires touching the ground. Check the tension at the position shown in the illustration. The normal vertical deflection is approximately 40 ~ 50 mm (1.6 ~ 2.0 in). If the deflection exceeds 50 mm (2.0 in) adjust the chain tension.

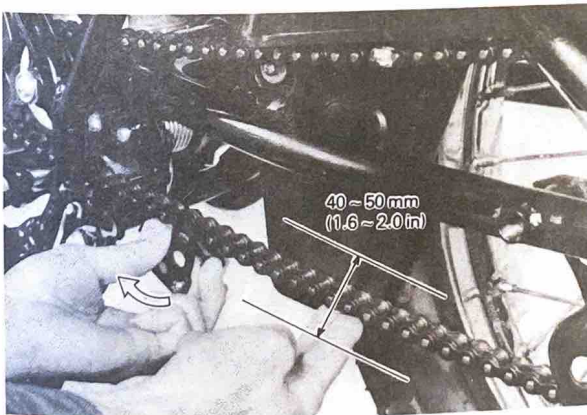

### NOTE:

Tension inspection and adjustment should be made with the tensioner in the relaxed position (not touching the chain).

### 2. Tension adjustment

- Loosen the rear brake adjuster.
- Remove the rear axle cotter pin.
- Loosen the rear wheel axle nut.
- Turn chain puller both left and right, until axle is situated in same puller slot position.

### NOTE:

Before adjusting, rotate rear wheel through several revolutions and check tension several times to find the tightest point. Adjust chain tension with rear wheel in this "tight chain" position.

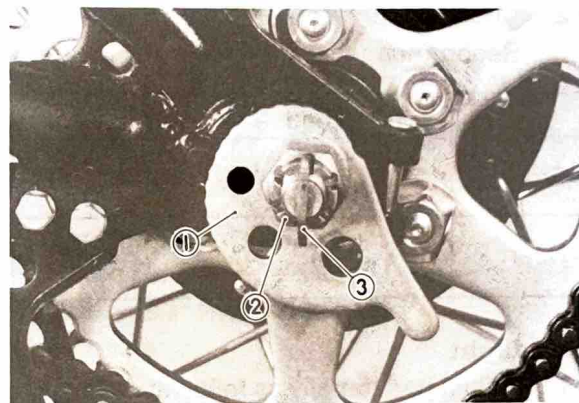

1. Chain puller 2. Axle nut 3. Cotter pin

- Tighten the rear axle nut.

Axle nut torque: 10.0 m·kg (72 ft·lb)

- Insert the new cotter pin into the rear wheel axle nut and bend the end of cotter pin. If the nut notch and pin hole do not match, tighten the nut slightly to match.

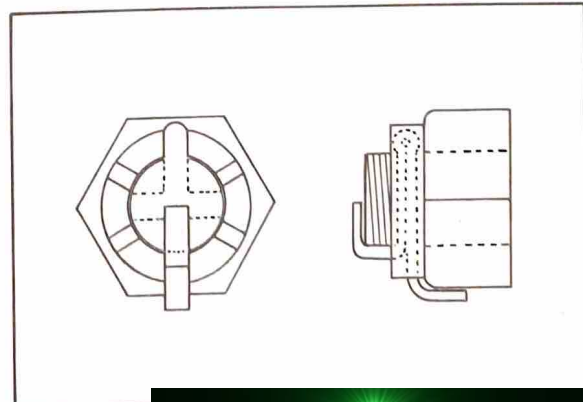

- g. In the final step, adjust the play in the brake pedal.

**CAUTION:**

Do not over tighten the chain. Excessive chain tension will overload the engine and other vital parts; keep the tension within the specified limits. Also, replace the rear axle cotter pin with a new one.

**Tires**

1. Check tires for damage during shipping. Be sure there is no oil or other slippery material on the tires.
2. Check tire pressure.  
Recommended pressures:

	Off-road	On-road
Front:	0.9 kg/cm <sup>2</sup> (13 psi)	1.7 kg/cm <sup>2</sup> (24 psi)
Rear:	1.1 kg/cm <sup>2</sup> (16 psi)	2.0 kg/cm <sup>2</sup> (28 psi)

**Headlight**

1. Adjust horizontally as follows:
  - a. Loosen the bolt holding the rim.  
To adjust to the right; move the lens assembly to right side.  
To adjust to the left; move the lens assembly to left side.



2. Adjust vertically as follows:
  - a. Remove the headlight lens and loosen the headlight shell mounting nuts.
  - b. Next, adjust vertically by moving the headlight body. When adjustment is complete hold the body in place, and tighten the two mounting nuts. Then refit headlight lens.

**Battery**

- a. Remove the battery from the battery box.

**CAUTION:**

Never try to add battery electrolyte (battery acid) to a battery that is installed on a machine. Even a skilled mechanic will spill enough acid to damage metal parts. Always remove the battery before filling with electrolyte and during charging. Always completely clean the exterior of the battery before re-installing.

- b. The battery must be charged properly before using for the first time. This initial charge will prolong the life of the battery. SEE TECHNICAL BULLETIN M7-075 FOR CHARGING DETAILS.

Charging current: 0.6A  
Charging hours: 10 hrs

- c. Electrolyte specific gravity

Specific gravity at 20°C (68°F) : 1.260

- d. Filling the battery with diluted sulfuric acid (electrolyte)
  - 1) Remove all filler caps from the battery, and remove the breather pipe cap at the same time.
  - 2) Cool the electrolyte down to below 30°C (80°F)
  - 3) Pour acid into each cell little by little up to the upper level line, and leave it for a while. When the battery fluid permeates the plates and separators, the fluid level begins to lower.  
Add electrolyte again.
  - 4) Charge the battery as required and measure the specific gravity of the fluid. Use a battery hydrometer.
  - 5) Install the filler caps, and thoroughly wipe off the fluid around the filler caps. Wipe off the battery completely before installation.

**WARNING:**

Battery fluid is poisonous and dangerous, causing severe burns, etc. Contains sulfuric acid. Avoid contact with skin, eyes or clothing.

Antidote:

**EXTERNAL**-Flush with water.

**INTERNAL**-Drink large quantities of water or milk. Follow with milk of magnesia, beaten egg or vegetable oil. Call physician immediately.

**Eyes:** Flush with water for 15 minutes and get prompt medical attention.

Batteries produce explosive gases. Keep sparks, flame, cigarettes, etc. away. Ventilate when charging or using in enclosed space. Always shield eyes when working near batteries. **KEEP OUT OF REACH OF CHILDREN.**

**Battery installation**

- a. Make sure the main switch is turned off, and install the battery in the battery box. Connect the positive lead wire first, and then connect the negative lead wire.

**CAUTION:**

Make sure battery leads are connected properly. Reversing leads can seriously damage the electrical system.

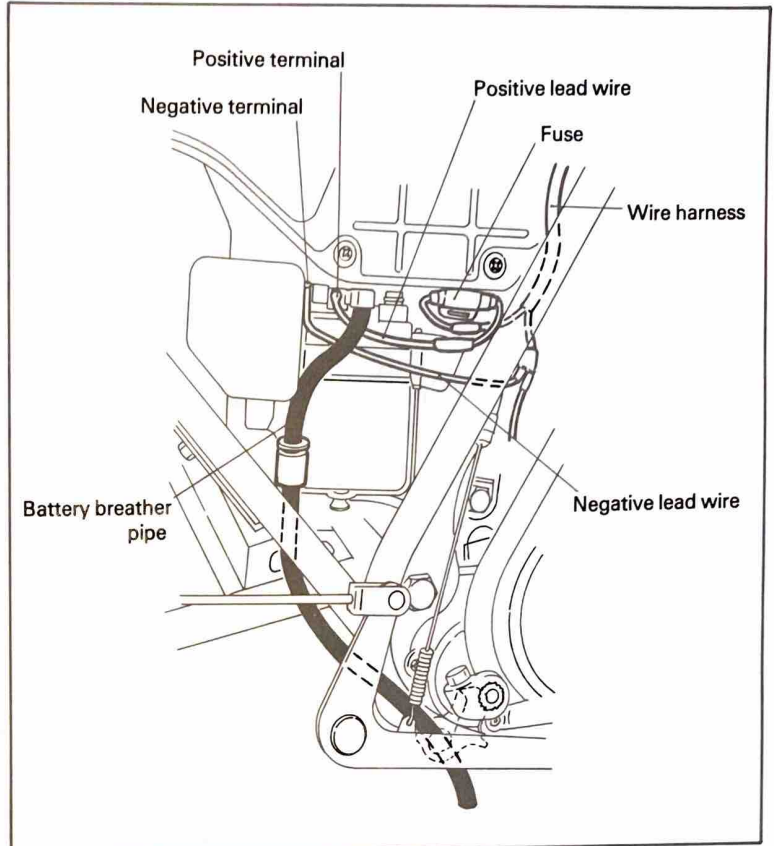

**Engine and transmission oil**

1. Engine

- a. Autolube oil

We recommend that first choice be Yamalube 2-cycle oil. If for any reason you should use another type, the oil should meet or exceed BIA certification "TC-W". Check container top or label for service specification. If above oils not available, use a 30W or 40W 2-stroke oil for air-cooled engines.

**CAUTION:**

Under extremely cold conditions (0°C or below) SAE 30 and 40W oils become very thick and will not flow as readily to the Autolube pump. This may cause oil pump starvation and engine damage.

2. Transmission

- a. To check level, start the engine and let it run for several minutes to warm and distribute oil. Stop engine. Unscrew the dip stick and wipe it clean. Set it on the case threads in a level position. Remove and check level.

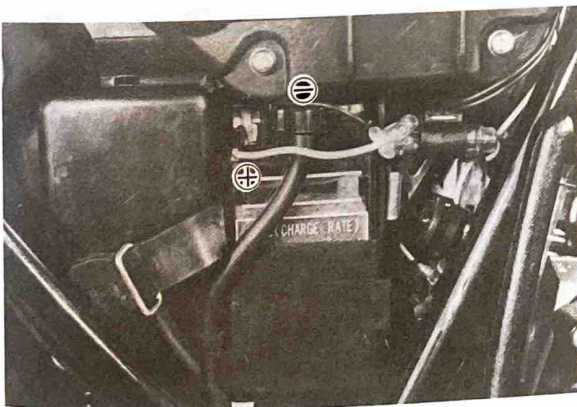

- b. The breather pipe should be connected as illustrated.

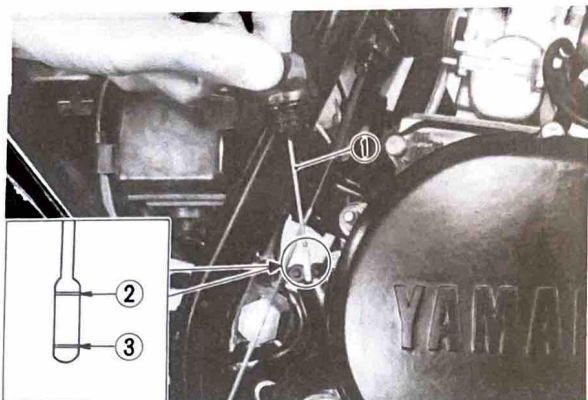

1. Dip stick 2. Max. level 3. Min. level

**NOTE:**

Be sure the machine is level and on both wheels.

b. The oil level should be between the minimum and maximum marks. Top off as required.

**Recommended oil:**

Yamalube 4-cycle oil or SAE 10W/30 "SE" motor oil or "GL" gear oil

**Transmission oil quantity:**

650 cc (0.7 US. qt) (Replacement)  
750 cc (0.8 US. qt) (Overhauling)

**Transmission drain plug torque:**

2.5 m·kg (18 ft·lb)

**CAUTION:**

Under no circumstances should any additives be included with the transmission oil. This oil also lubricates and cools the clutch. Many additives will cause severe clutch slippage.

**Fuel petcock**

1. Clean fuel filter and filter cup.

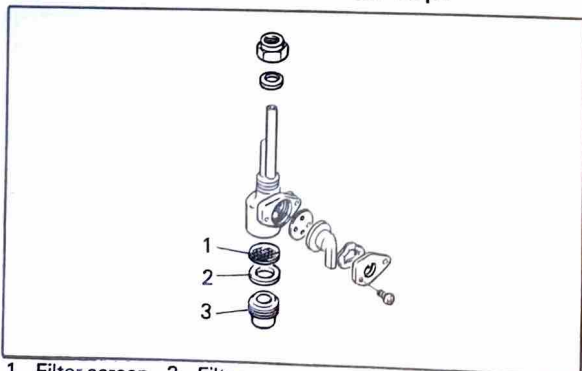

1. Filter screen 3. Filter cup  
2. Filter gasket

**Ignition timing for DT125F**

1. Ignition timing is checked with a timing light by observing the position of the stationary pointer stamped on the crankcase and the marks on the magneto flywheel.
2. Connect one lead wire of timing light to spark plug lead wire, and the other to the battery.
3. Start the engine and keep the engine speed as specified. Use a tachometer for checking.

Engine speed: 1,350 ~ 1,500 r/min

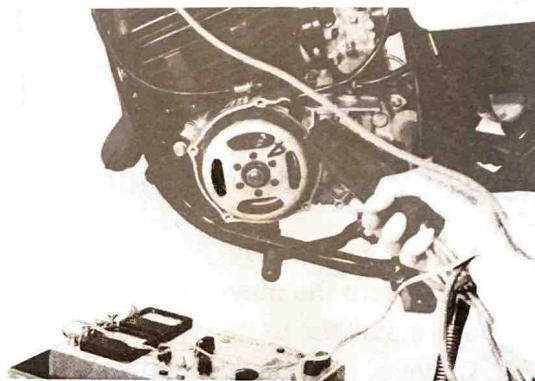

4. The center mark of the magneto flywheel should line up the stationary pointer on the crankcase at a specified engine speed.

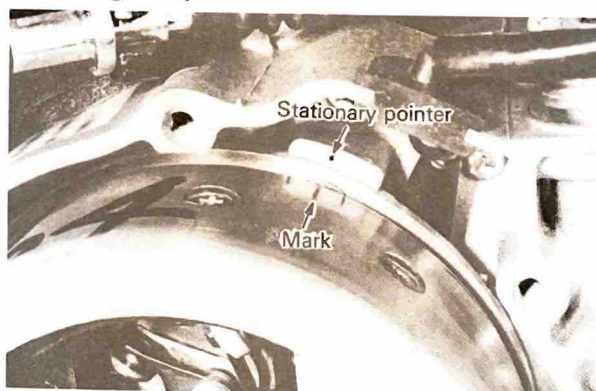

5. If they are not aligned or a new crankcase is used for replacement, proceed as follows.
6. Switch on point checker and adjust zero point. Disconnect magneto harness from main harness, connect red lead of point checker to black/white lead in wire harness coming from magneto.
7. Connect black lead of point checker to unpainted surface of cylinder fin or unpainted crankcase bolt.

8. Rotate magneto flywheel until the center mark on the magneto flywheel lines up with the stationary pointer on the crankcase. At this time, point checker needle should swing from "CLOSE" to "OPEN" position, indicating the contact breaker (ignition points) have just begun to open.

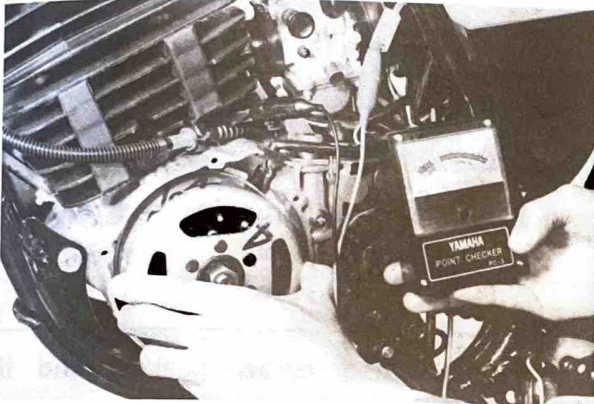

9. Adjust ignition timing by slightly loosening Phillips head screw and carefully rotating contact breaker assembly with a slotted screw driver, and retighten Phillips head screw before rechecking timing. Recheck the timing by repeating step 8 and 2-4.

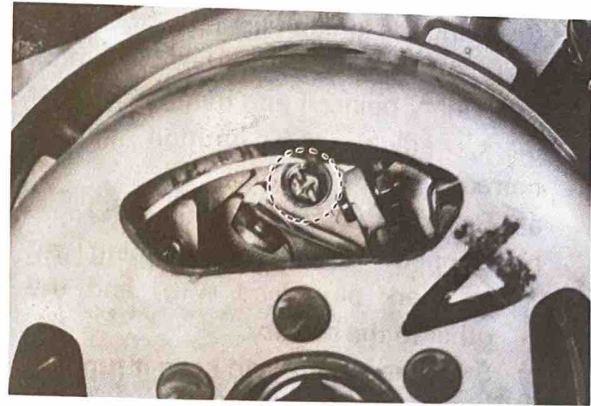

**NOTE:**

After ignition timing has been set, check point gap. If it is over tolerance, (0.3 ~ 0.4 mm (0.012 ~ 0.016 in) ), the contact breaker assembly should be replaced. Do not attempt to bend the fixed point breaker to decrease maximum point gap. This will only result in point misalignment, difficulty in setting timing and premature point failure.

**Ignition timing for DT175F (C.D.I.)**

1. Ignition timing is checked with timing light by observing the position of the stationary pointer marked on the crankcase and the marks on the C.D.I. magneto flywheel.

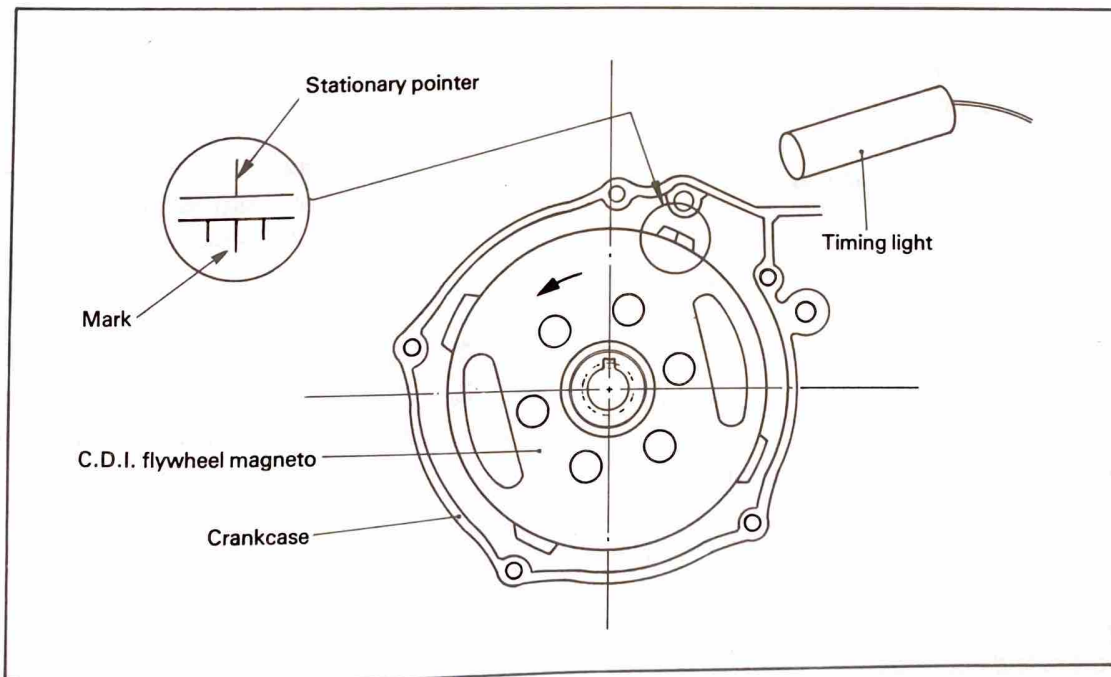

2. Checking the ignition timing
 

Using the timing light, the case mark (stationary pointer) and magneto center mark, adjust the ignition timing correctly.

  - a) Remove the crankcase cover (L).
  - b) Connect one lead wire of timing light to spark plug lead wire, and the other to the battery.
  - c) Start the engine and keep it running at the specified speed.

Specified speed: 2,000 r/min
------------------------------

- d) While running the engine at the specified speed, check to see that the stationary pointer is aligned with the magneto center mark. If the marks are out of alignment, follow the steps below.

3. Adjusting the ignition timing
  - 1) Remove the crankcase cover (L) and flywheel.
  - 2) Loosen base set screw and turn base until the stationary pointer and the mark on the base align.
  3. Tighten base set screw and install flywheel.
  - 4) Run engine and check marks for alignment by means of timing light.
  - 5) Repeat procedure (above steps 2-4) until marks align.
  - 6) Re-install crankcase cover (L).

### Autolube pump

#### Air bleeding

The Autolube Pump and delivery lines must be bled on the following occasions:

- Setting up a new machine out of the crate.
- Whenever the Autolube tank has run dry.
- Whenever any portion of the Autolube system is disconnected.
- If the machine lies on its side after falling over.

- a. Bleeding the pump case and/or oil pipe
  - 1) Remove the bleed screw.

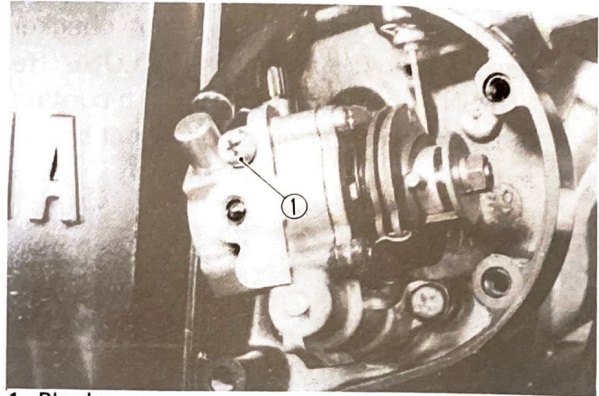

1. Bleed screw

- 2) Keep the oil running out until air bubbles disappear.

#### NOTE:

Check the bleed screw gasket, and if damaged, replace with a new one.

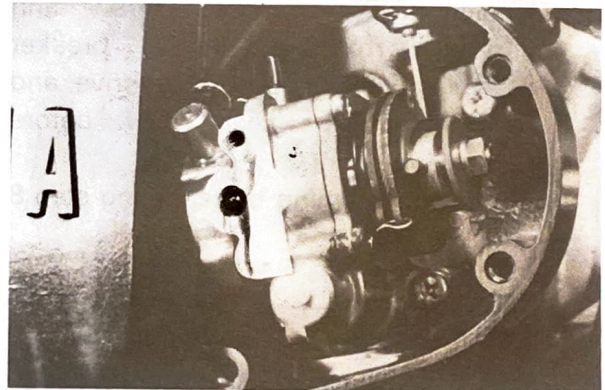

- 3) When air bubbles are expelled completely, tighten the bleed screw and install the pump cover.
- b. Bleeding the pump distributor and/or delivery pipe
    - 1) Start the engine.
    - 2) Pull the pump wire all the way out to set the pump stroke to a maximum.

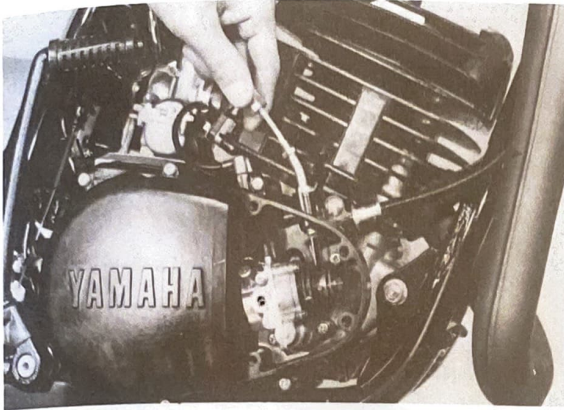

### Spark plug

- a. Check spark plug gap and torque.

Standard spark plug: N-3 (CHAMPION)

Spark gap:  
0.6 ~ 0.8 mm (0.024 ~ 0.031 in)

Spark plug torque: 2.5 m·kg (18 ft·lb)

- b. When installing the plug, always clean the gasket surface. Wipe off any grime from the threads and torque the spark plug properly.

### NOTE:

It is difficult to bleed the distributor completely with the pump stroke at a minimum, and therefore the pump stroke should be set to a maximum.

- 3) Keep the engine running at about 2,000 r/min for two minutes or so, and both distributor and delivery pipe can be completely bled.

### Specification Table

Ignition timing:	1.8 ± 0.15 mm (0.17 ± 0.006 in) (B.T.D.C.)	
Contact breaker point gap:	0.3 ~ 0.4 mm (0.012 ~ 0.016 in)	
Carburetor:	DT125F	DT175F
Main jet	#125	#160
Pilot jet	#22.5	#20
Needle jet	N-4	N-4
Jet needle - Clip position	5GL8-3	5J11-4
Throttle valve cut away	2.0	2.0
Idling engine speed	1,350 ~ 1,500 r/min	
Fuel tank capacity:	6.8 lit. (1.8 US gal.)	
Oil tank capacity:	1.0 lit. (1.1 US qt)	

[www.legends-yamaha-enduros.com](http://www.legends-yamaha-enduros.com)



[www.legends-yamaha-enduros.com](http://www.legends-yamaha-enduros.com)



**YAMAHA MOTOR CO., LTD.**

IWATA, JAPAN

PRINTED IN JAPAN  
78 · 5 — 2.15 × 10