



Hasty
YAMAHA MOTOR CORPORATION, U. S. A.

6620 ORANGETHORPE AVENUE · BUENA PARK, CALIFORNIA 90620

MAIL ADDRESS: P.O. BOX 6620, BUENA PARK, CALIFORNIA 90622

PHONE: (714) 522-9444

June' 20, 1977

Y.M.U.S.

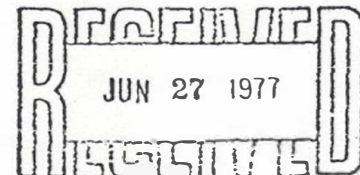
MOTOCROSS SUPPORT GROUPYZ RACING INFORMATION #7
www.legends-yamaha-enduros.com
SUBJECT: YZ 125D, 34MM CARBURETORS

After modifying the YZ 125D engine as described in racing bulletin (4), changing the carburetor size to 34mm will increase usable horsepower.

*Mikuni 34mm carburetor (YZ125X, part number IG8-14101-00).

Main jet	----- 300~310	Pilot jet	--- 40
Needle jet	--- Q2	Air jet	----- 2.0
Needle	----- 6F15-2	Air screw	--- 1 1/4
Slide	----- 3.0		

SUBJECT: YZ 250D, STEP II MODIFICATIONS

We have been testing these 250 specifications for several weeks. Reports indicate these are excellent modifications.

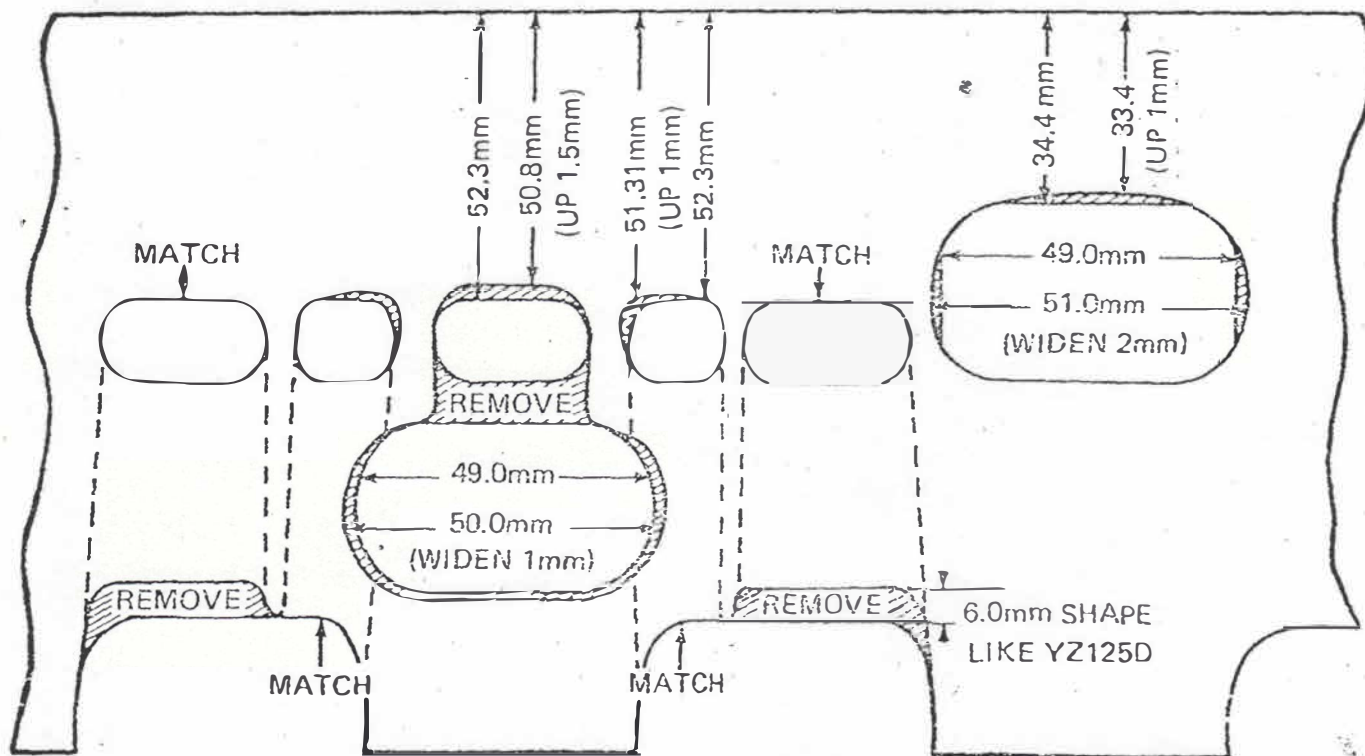
STEP II MODIFICATIONS

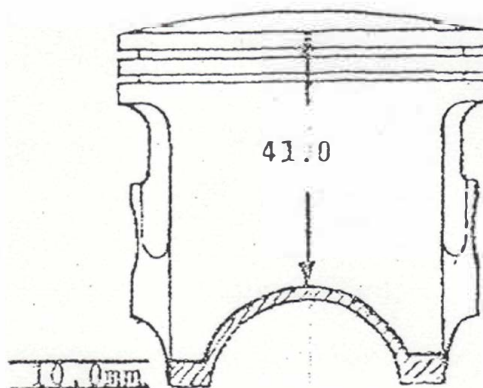
MOTOCROSS SUPPORT GROUPYZ RACING INFORMATION #7 CONT.JUNE 20, 1977*Carburetion 38mm Mikuni

Type -----	YZ 400D	Head -----	.010" milled
Main jet -----	#390	Exhaust ---	Std.
Needle jet ---	Q0	Timing ----	Std.
Needle -----	6F15		

SUBJECT: CHAIN TENSIONERS, ALL YZ's

We have recently evaluated R & R chain tensioners for the 125, 250, and 400 YZ's. These tensioners appear to be excellent and control the chain slack very well. They are available from:

R & R Machine & Products
1453 Virginia Street
Building L
Baldwin Park, CA 91706
(213) 337-1595

SUBJECT: SWING ARMS, ALL YZ's

Several riders have installed Pro-Fab swing arms and report good results. The 125 arm is 12mm longer and 2½ pounds lighter. The 250/400 is 35mm longer and 2 3/4 pounds lighter. They are available from:

PRO-FAB
3185 C Airway
Costa Mesa, CA
92626
(714) 751-6264

*Carburetor jetting may vary due to altitude, track condition, and weather. Should there be jetting problems with these carburetor specifications, we have alternate jet information available.

MOTOCROSS SUPPORT GROUPYZ RACING INFORMATION #7 CONT.JUNE 20, 1977SUBJECT: AIR FILTERS, ALL YZ'S

We are still recommending the Phase II filters by JT Racing. Riders are continuing to have problems with dirt wearing out the bores and rings. Improper filter oil and service is one cause. Another is improper fitting when installing the filter and finally examining the air box and manifold joints for possible dirt leaks. They are available from:

JT Racing Imports
303 W. 35th Street
Suite D
National City, CA 92050
(714) 479-9696

SUBJECT: YZ 125D CONNECTING ROD MODIFICATION

The width of the connecting rod small end has been increased from 16mm to 18mm. This is the same rod as used in the YZ 125X.

PART NUMBER CHANGE:

Crank assembly	1W1-11400-00	SS to 1W1-11400-01
Connecting Rod	1W1-11651-00	SS to 1G8-11651-00

The above parts are independently interchangeable. Rod bearings remain the same. Make the necessary change in your parts book.

SUBJECT: YZ 250, 400D PARTS BOOK ERROR

On page 14, figure number 23 the 3rd gear wheel, 26t has been completely omitted. It pertains to the YZ 250D only. That part number should be 1W5-17231-00. Part number 1M1-17231-00 is the 3rd gear wheel, 26t for only the YZ 400D.

SUBJECT: 1978 MOTOCROSS SUPPORT PROGRAM

Many rider reports are coming through very thoroughly filled out with excellent and useful tuning data. Other reports contain details and excuses as to why the rider fell off, ect. Your part in this program is to relay useful information, not B.S. Think about your own report and ask yourself, "will Yamaha need me for testing again next year?"

Hasty Horn



YAMAHA MOTOR CORPORATION, U. S. A.

6620 ORANGETHORPE AVENUE - BUENA PARK, CALIFORNIA 90620

MAIL ADDRESS: P.O. BOX 6620, BUENA PARK, CALIFORNIA 90622

PHONE: (714) 522-9444

March 8, 1977

Y.M.U.S.

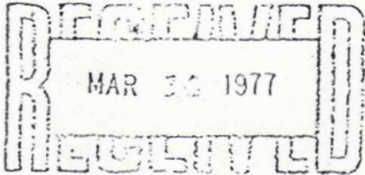

ATLANTA

MOTOCROSS SUPPORT GROUP

YZ RACING INFORMATION

4

SUBJECT: YZ125 Porting specifications



Many 125 riders have requested information to increase engine RPM and horsepower .

Our testing department recently spent one week here at YMUS, dyno testing every rumored fact or fiction possibility to increase horsepower. They tried every configuration of brand XX pipes, special CDI systems, back ports, cross ports and trick carburetors.

As a final result, the greatest increase came from the following combination:

EXHAUST PORT

PROFILE

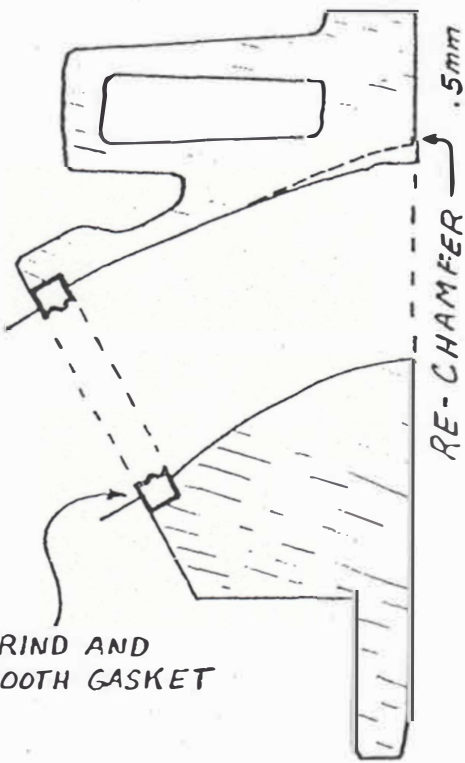

FACE

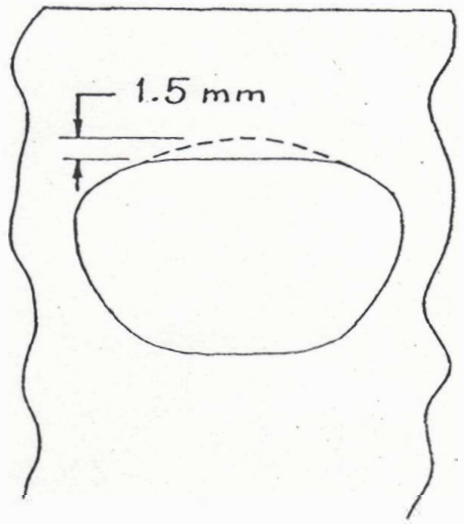

ROUND EXHAUST PORT
UPWARD 1.5mm

GRIND AND
SMOOTH GASKET

YZ RACING INFORMATION

#4 CONT.



INTAKE PORT

PROFILE

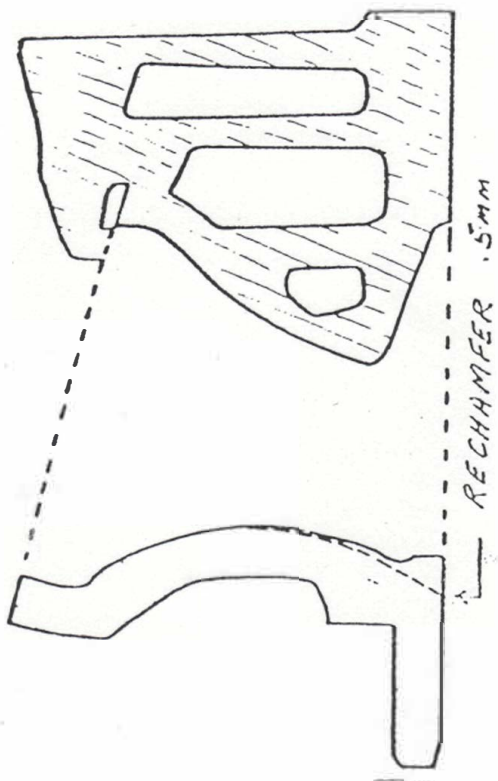

FACE

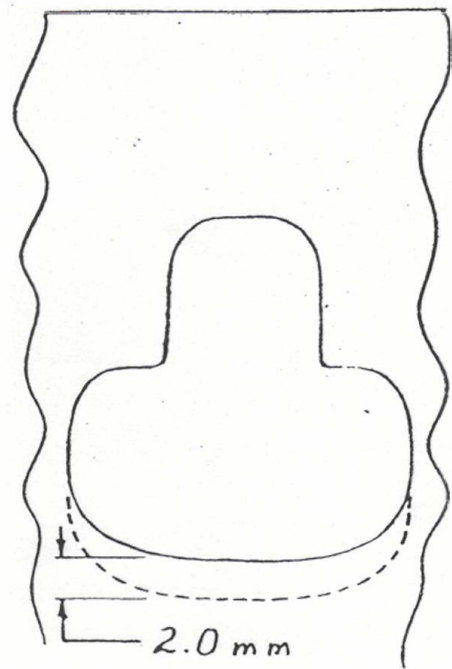

LOWER INTAKE PORT
2 mm ACROSS BOTTOM

HEAD

Compression change. (To compensate for exhaust change).

PROFILE

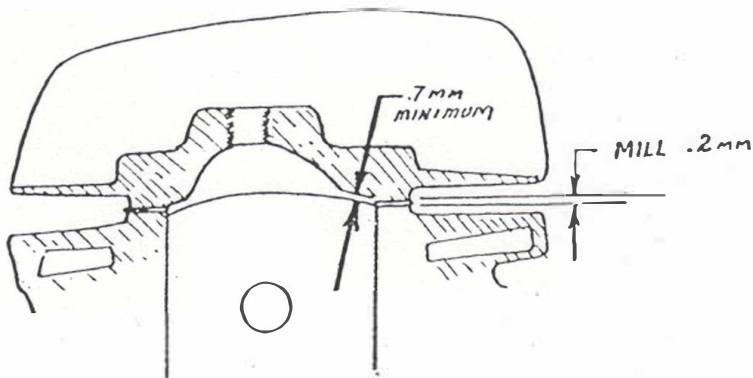

Mill the head .2mm or make a .3mm gasket.

YZ RACING INFORMATION

#4 CONT.

After installing the head, mash a piece of solder between the bolted down head, and the piston crown. This crushed solder must indicate at least .7mm of piston to head clearance. If not, machine the squish area of the head to obtain this clearance.

Further experimental modification is not recommended at this time.

The combination of these three items will give you 2 horsepower more on top end and will result in 1000 more RPM's.

Keep in mind, higher overall RPM and horsepower produces a peakier engine and less low end power. There will be some loss of overall engine life and reliability.

With these porting specifications consider one size larger main jet.

YZ 125D SUPPORT RIDERS:

If your machine is still relatively stock, please try these porting specifications as soon as possible and express your opinion on your next weekly report.

MOTOCROSS SUPPORT

Subject: Carburetion, changing YZ 125D 32mm carburetors to larger YZ 125X 34mm for increased performance with ported engines.

Use a YZ 125X carburetor. Part number 1G8-14101-00

COMPARISON

www.legends-yamaha-enduros.com

1976 YZ125X 34mm	1977 YZ125D 32mm	Modified 34mm For use on 'D'	1978 YZ125E
M.J. 310 N.J. Q6 N. 6F15 SL. 3.5 P.J. 60	M.J. 310 N.J. P8 N. 6F22 SL. 3.0 P.J. 60	M.J. 300 N.J. Q2 N. 6F15 SL. 3.0 P.J. 40 A.S. 1½	Coming Later

Yamaha part numbers:

Main jet	#300	#137-14143-60
Needle jet	Q2	#278-14141-52
Needle	6F15	#239-14116-15
Pilot jet	#40	#193-14142-40
Slide	3.0	#509-14112-30

Head v_c me 23.2 cc (STD.) *Hasty Horn*

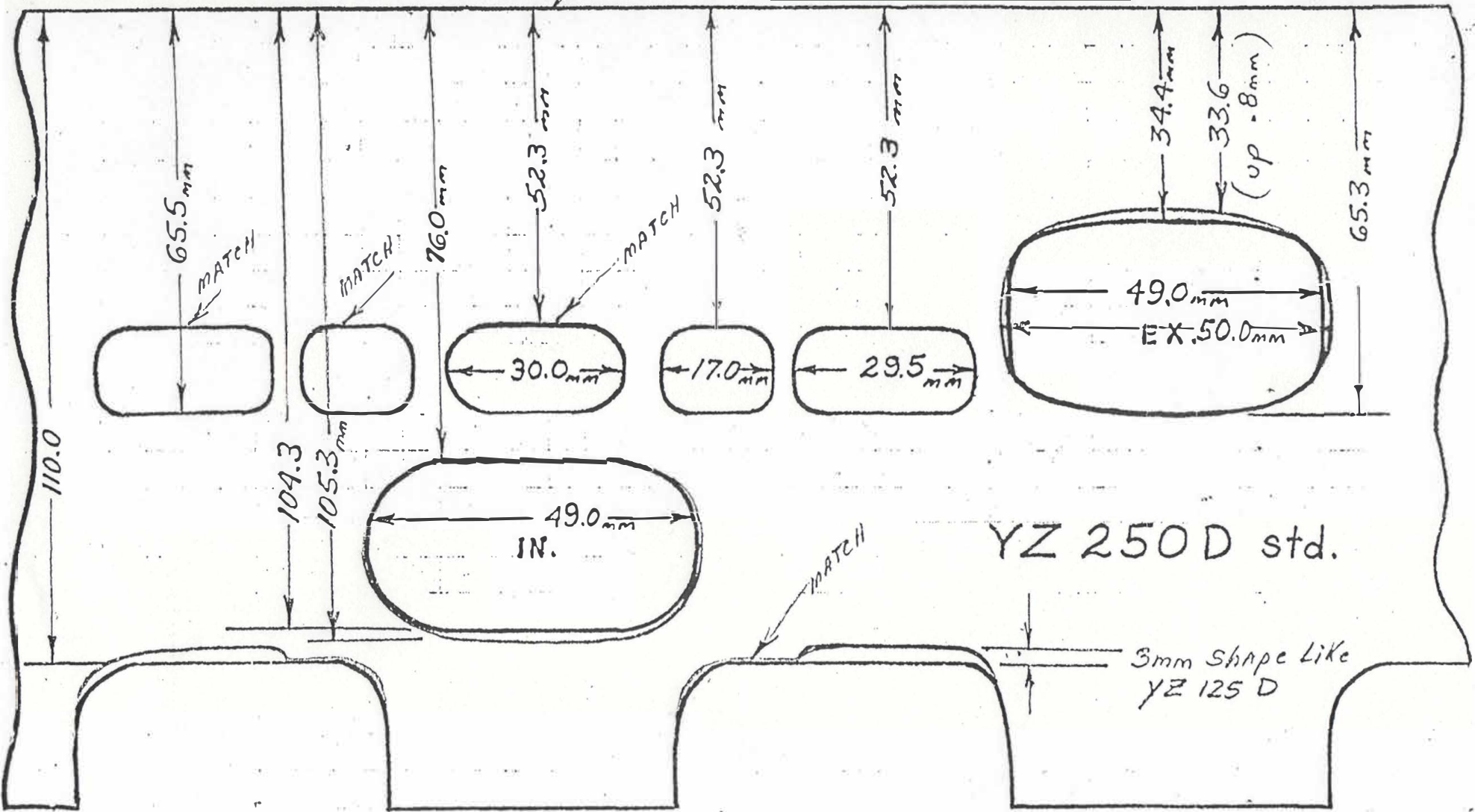

STEP I MODIFICATIONS

Carburetion STD.
 TYPE
 M.J. } STD.
 N.J.
 Needle. }

Head..... -010 mm
 Exhaust Silencer. STD.
 Exhaust Pipe.... STD.
 Timing..... STD.

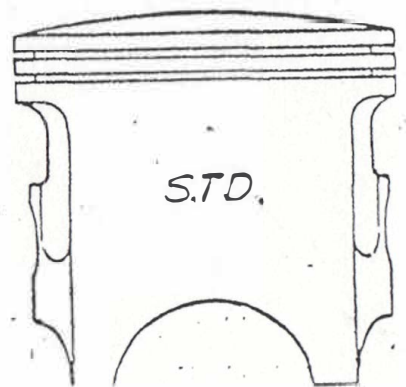

5/27/

Head volume 23.2 cc (std.) *Hasty Horn*

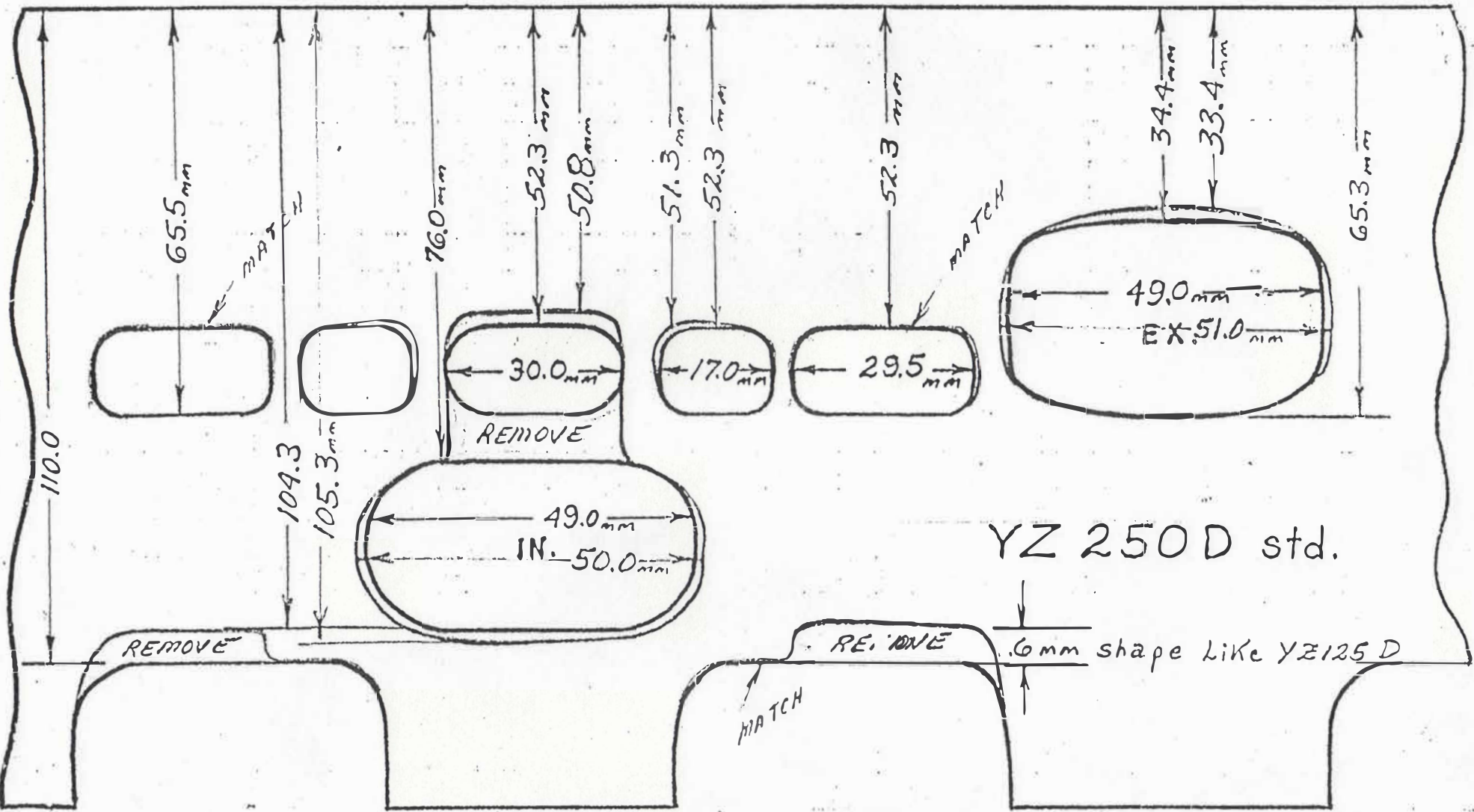

STEP II MODIFICATIONS

Carburetion 38mm
 TYPE.... YZ 400 D
 M.J. # 390
 N.J. QO
 Needle. 6F15

Head..... -010 mm
 Exhaust Silencer. STD.
 Exhaust Pipe.... STD.
 Timing..... STD.

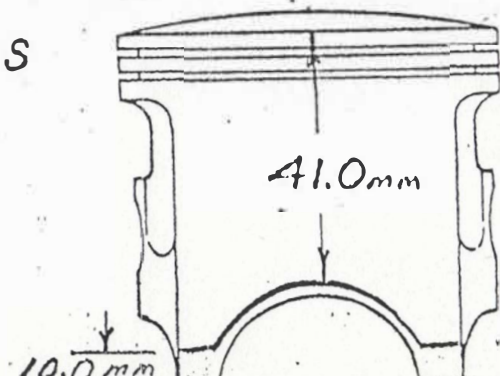

5/27/71

[Signature]