

GENUINE



[www.legends-yamaha-enduros.com](http://www.legends-yamaha-enduros.com)

# GT 80 F

# OWNER'S MANUAL

LIT-11626-01-28

**IMPORTANT: PLEASE READ THIS MANUAL CAREFULLY AND COMPLETELY BEFORE OPERATING THIS VEHICLE.**

Particularly important information is distinguished in this manual by the following notations:

**NOTE:** A NOTE provides key information to make procedures easier or clearer.

**CAUTION:** A CAUTION indicates special procedures that must be followed to avoid damage to the machine.

**WARNING:** A WARNING indicates special procedures that must be followed to avoid injury to a machine operator or person inspecting or repairing the machine.

**GT80F OWNER'S MANUAL**

1st Edition - April 1978

2nd Printing - December 1979 JEM

ALL RIGHTS RESERVED BY  
YAMAHA MOTOR CORPORATION, U.S.A.  
BUENA PARK, CALIFORNIA 90620

**LIT-11626-01-28**

## **INTRODUCTION**

Congratulations on your purchase of the Yamaha GT80F. This model represents the product of many years of Yamaha experience in the production of fine sporting, touring, and pace-setting racing machines. You can now appreciate the high degrees of craftsmanship and reliability that have made Yamaha a leader in these fields.

**PLEASE READ THIS MANUAL CAREFULLY AND COMPLETELY BEFORE OPERATING YOUR NEW MACHINE.** This manual will provide you with a good basic understanding of the features, operation, and basic maintenance and inspection items of this vehicle. If you have any questions regarding the operation or maintenance of your machine, please consult your Yamaha dealer.

### **NOTICE:**

**Some data in this manual may become outdated due to improvements made to this model in the future. If you have any question regarding this manual or your machine, please consult your Yamaha dealer.**

This Yamaha motorcycle in its design and manufacture fully complies with the emissions standards for clean air applicable at the time of manufacture.

Yamaha has met these standards without reducing the motorcycle's performance or economy of operation. To maintain these high standards it is important that you and your dealer pay close attention to the recommended maintenance schedules and operating instructions contained within this manual.

**SERVICE DEPT.  
INTERNATIONAL DIVISION  
YAMAHA MOTOR COMPANY, LTD.**

# CONTENTS

	PAGE
DESCRIPTION .....	1
MACHINE IDENTIFICATION.....	2
CONTROL FUNCTIONS .....	3
PRE-OPERATION CHECKS.....	10
OPERATION AND IMPORTANT RIDING POINTS .....	13
PERIODIC MAINTENANCE AND MINOR REPAIR.....	18
CLEANING AND STORAGE.....	40
MISCELLANEOUS .....	43
SPECIFICATIONS .....	45
WARRANTY INFORMATION .....	50

# DESCRIPTION

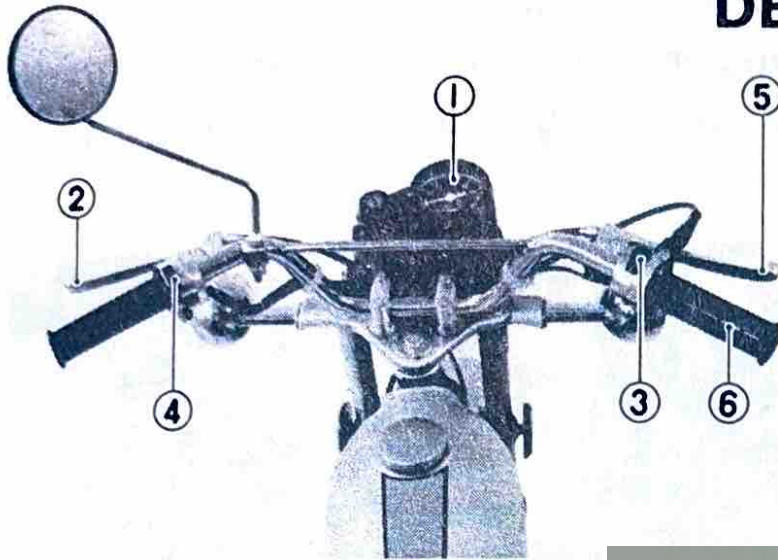

**INSTRUMENTS**

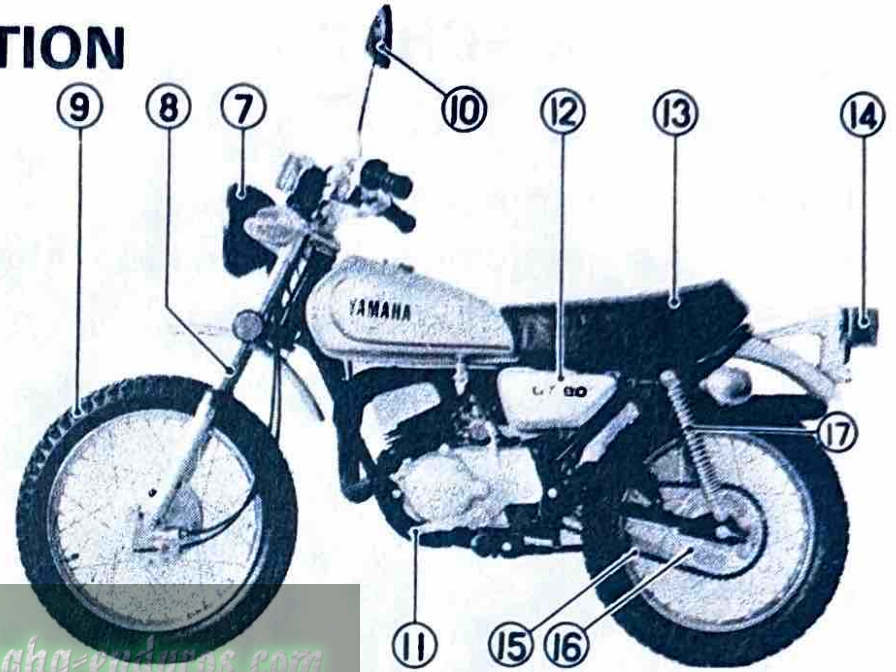

**LEFT SIDE**

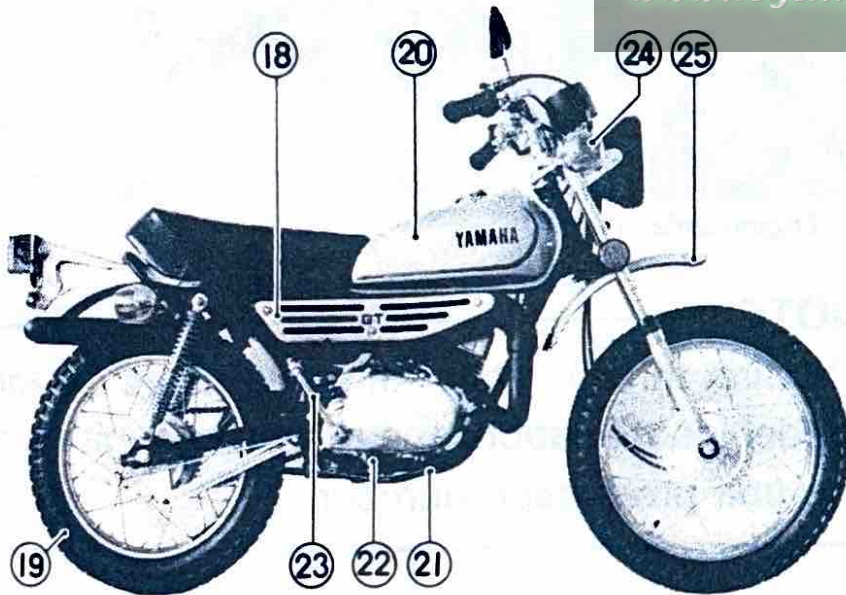

**RIGHT SIDE**

[www.legends-yamaha-enduros.com](http://www.legends-yamaha-enduros.com)

- |                       |                         |
|-----------------------|-------------------------|
| 1. Speedometer        | 14. Taillight           |
| 2. Clutch lever       | 15. Chain               |
| 3. Engine stop switch | 16. Sprocket wheel      |
| 4. Handle switch      | 17. Rear shock absorber |
| 5. Brake lever        | 18. Muffler             |
| 6. Throttle grip      | 19. Rear wheel          |
| 7. Head light         | 20. Fuel tank           |
| 8. Front fork         | 21. Brake pedal         |
| 9. Front wheel        | 22. Foot rest           |
| 10. Rear view mirror  | 23. Kick crank          |
| 11. Change pedal      | 24. Flasher light       |
| 12. Oil tank          | 25. Front fender        |
| 13. Seat              |                         |

# MACHINE IDENTIFICATION

## Frame serial number

The frame serial number is stamped on the right side of the steering head pipe.

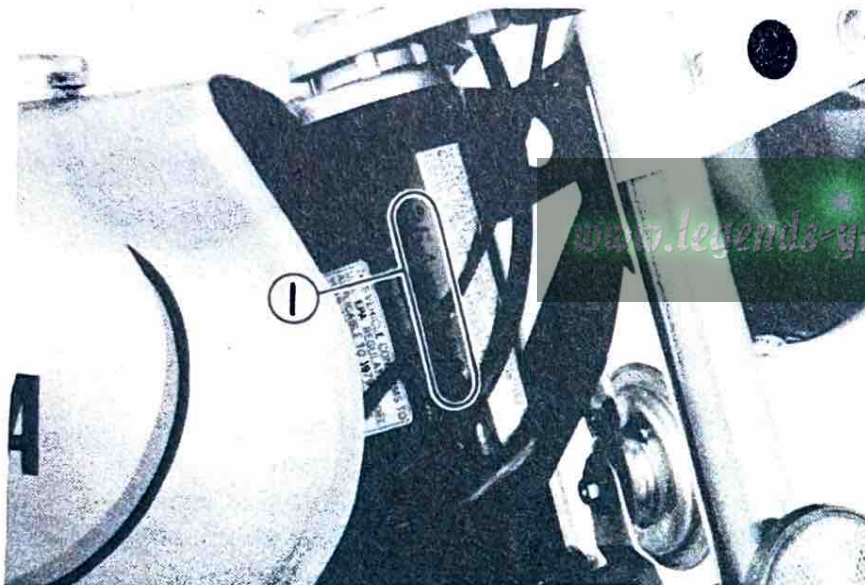

1. Frame serial number

## Engine serial number

The engine serial number is stamped into the raised part of the left rear section of the engine.

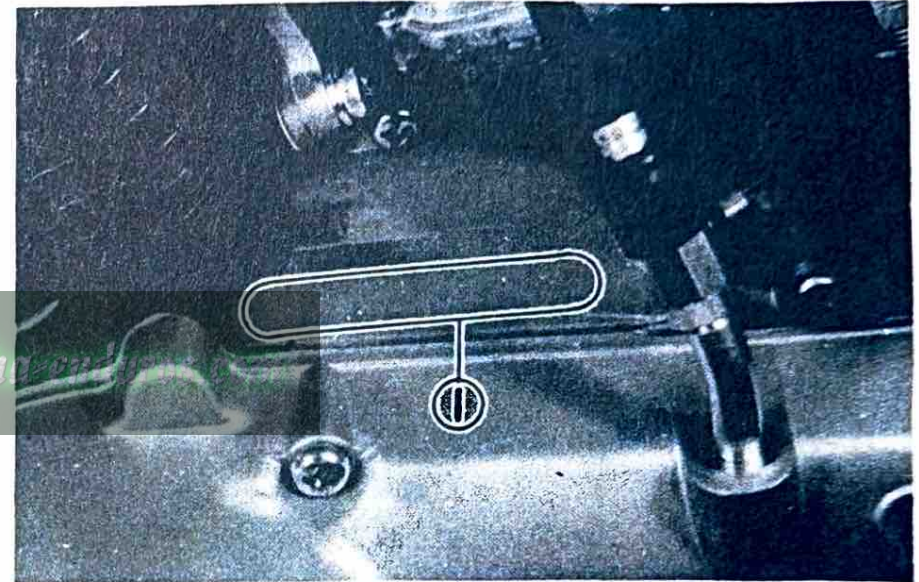

1. Engine serial number

## NOTE:

The first three digits of these numbers are for model identification; the remaining digits are the unit production number.

# CONTROL FUNCTIONS

## Main switch

According to the main key position, the ignition and lighting systems can be used as follows:

Key position	Description	Key removal
OFF	All electrical systems inoperative. Engine cannot be started. Lights and horn with not function.	Possible
ON	Engine can be operated. Turn, brake and horn circuits can be operated. Taillight always on and, with the engine running, the headlight and meter light come on automatically. Headlight and meter light function only when the engine is running.	Not possible

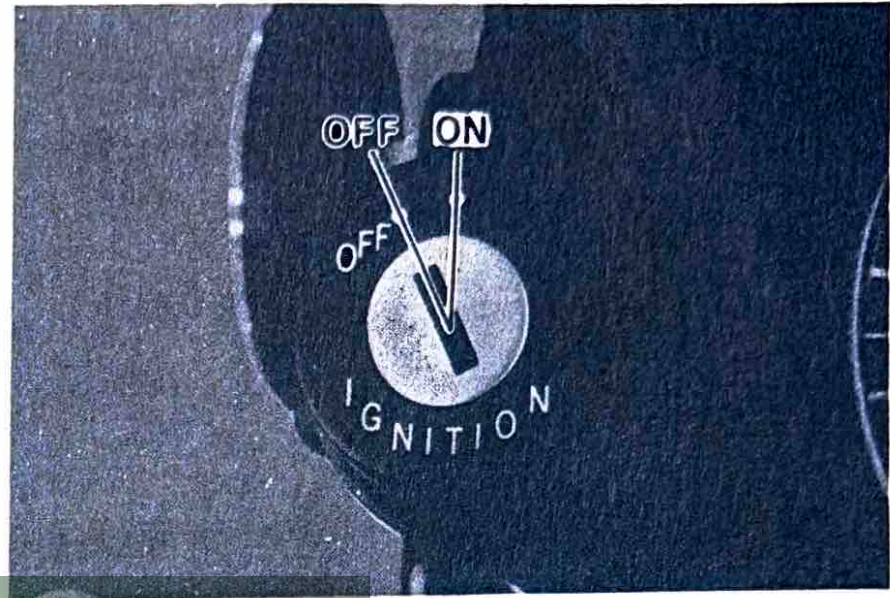

[www.legends-yamaha-enduros.com](http://www.legends-yamaha-enduros.com)

## Handlebar switches

The handlebar switches are located near the right and left handle grips and are used for the following functions:

### “ENGINE STOP” switch

Make sure that the engine stop switch is turned to “RUN” position. The engine stop switch has been equipped to ensure safety in an emergency such as when the motorcycle is upset or trouble takes place in the throttle

system. The engine will not start or run when the engine stop switch is turned to "OFF". In case of an emergency, turn the stop switch forward to shut off the engine.

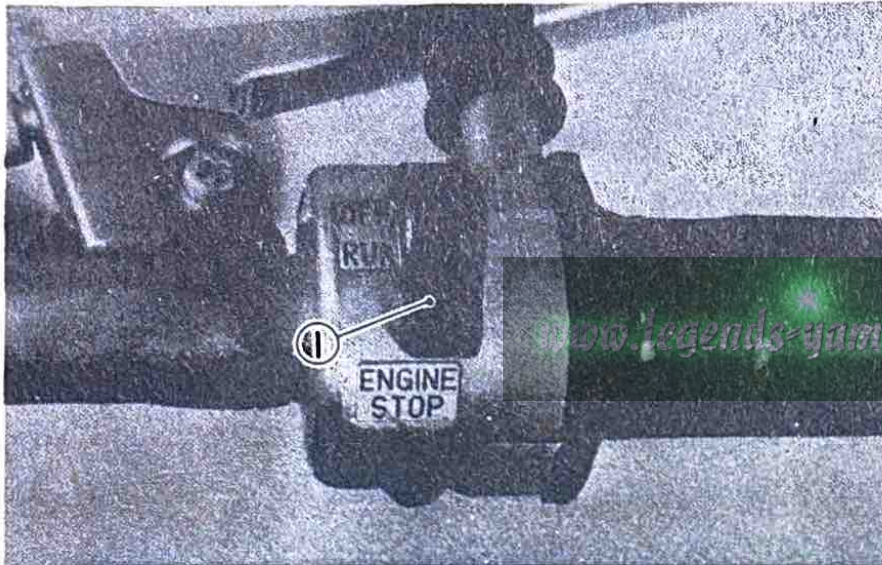

1. "ENGINE STOP" switch

### "LIGHTS" switch (dimmer)

Turn to the "HI" position for the high beam and to the "LO" position for the low beam.

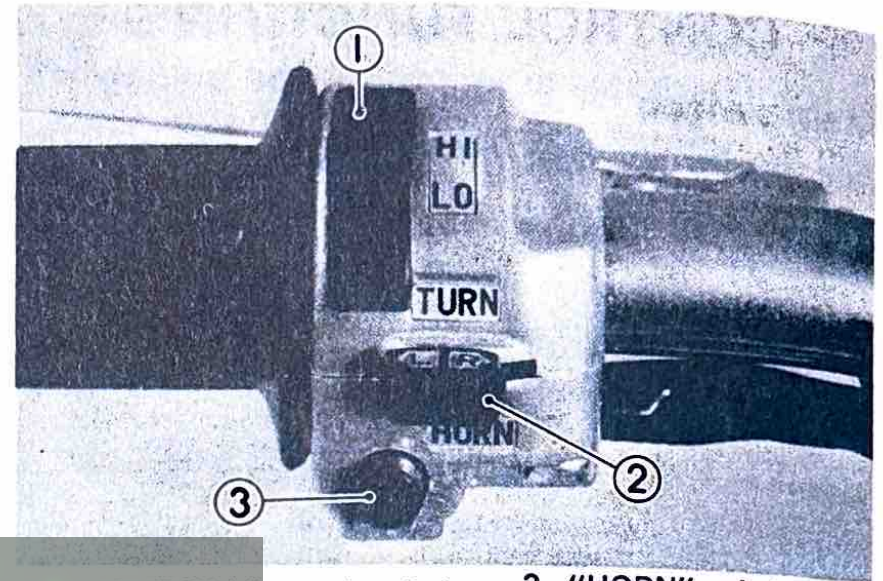

1. "LIGHTS" (dimmer) switch  
2. "TURN" switch  
3. "HORN" switch

### "TURN" switch

This is a three-way switch: the center position is off; turn to the "L" position for the left flasher and to the "R" position for the right flasher. Be sure to turn the switch off after completing a turn.

### "HORN" switch

Press the button to sound the horn.

## Indicator lights

**“TURN”** indicator light (orange):

This light flashes while either turn signal is ON.

**“HIGH BEAM”** indicator light (blue):

This light comes on when the headlight high beam is used.



1. TURN light
2. HIGH BEAM light
3. OIL light

**“OIL”** caution light (red):

The light comes on when there is little oil in the oil tank, thus warning the rider. The rider can check the circuit by pressing the horn button.

**NOTE:** \_\_\_\_\_  
If the oil caution light will not light up during this test, have your Yamaha dealer check it. Of course, check the oil level first.

**CAUTION:** \_\_\_\_\_  
**Do not run the machine until you know the machine has enough oil.**

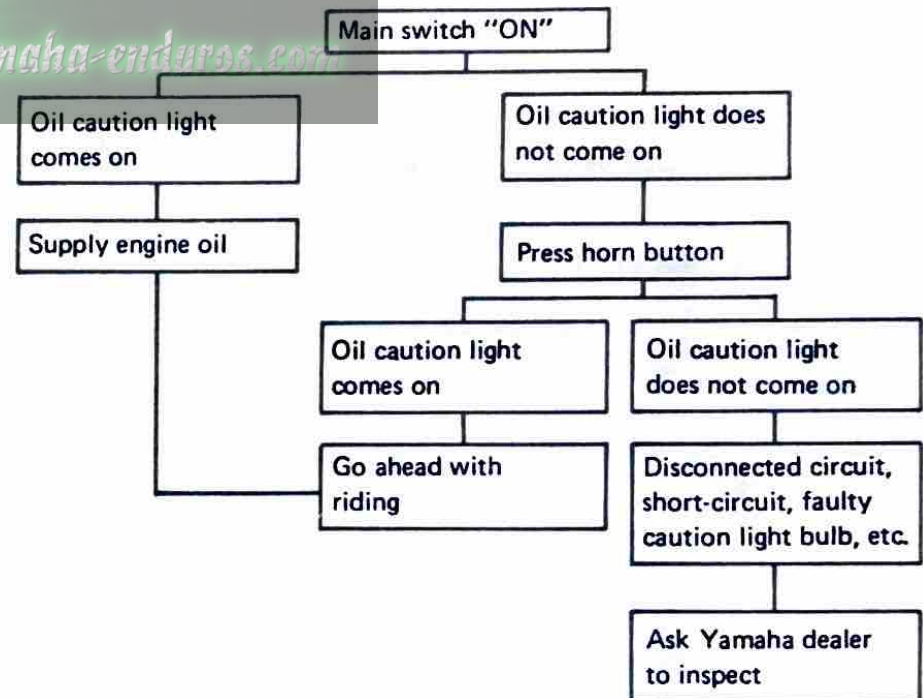

## Fuel petcock

The fuel petcock supplies fuel from the tank to the carburetor while filtering the fuel. The fuel petcock has three positions:

**OFF:** With the lever in this position fuel will not flow. Always return the lever to this position when the engine is not running.

**ON:** With the lever in this position fuel flows to the carburetor. Normal riding is done with the lever in this position.

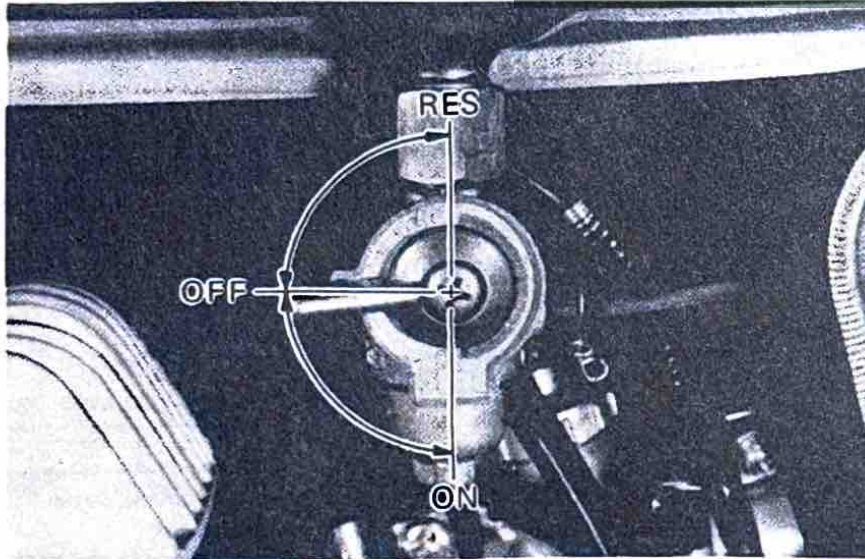

**RES:** This indicates "RESERVE". If you run out of fuel while riding, move the lever to this position. THEN, FILL THE TANK AT THE FIRST OPPORTUNITY.

## Starter lever (CHOKE)

When cold, the engine requires a richer fuel mixture for starting. A separate starter circuit, which is controlled by the starter lever, supplies this mixture.

Push the lever down to open the circuit (for starting) and pull it up to close the circuit before riding. See "Starting Instructions" before attempting to start the engine.

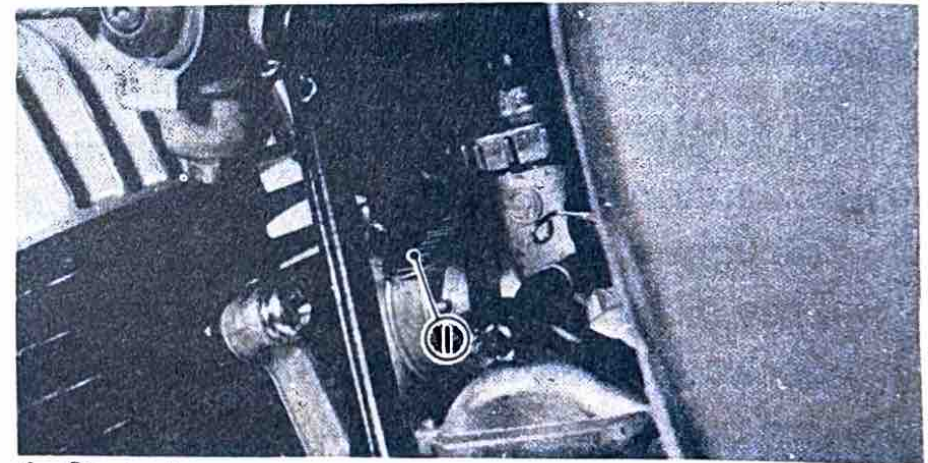

1. Starter lever

## Kick starter

To start the engine, rotate the kick crank, push down lightly with your foot until the gears engage, and then kick smoothly and forcefully. This model has a primary kick starter so the engine can be started in gear if the clutch is disengaged. In normal practice, however, shift to neutral before starting.



## Seat lock

To open the seat lock, insert the key in the lock and turn it clockwise.

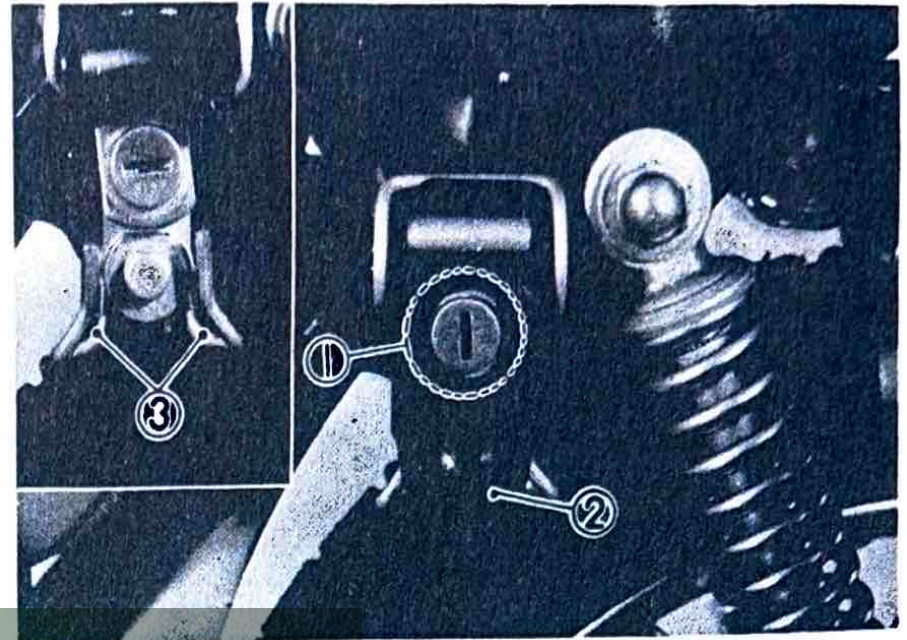

1. Seat lock 2. Seat latch 3. Helmet hanger

## Seat latch

The seat is hinged to the frame on one side and secured by the seat latch on the other side. To check the battery fluid, add engine oil, or take out the service tools, pull the seat latch lever out, free the seat latch from the hook, and lift the seat.

## CAUTION:

To avoid damage to the battery, do not store anything under the seat.

## Front brake lever

Pull the brake lever toward the handlebar to activate the front brake.

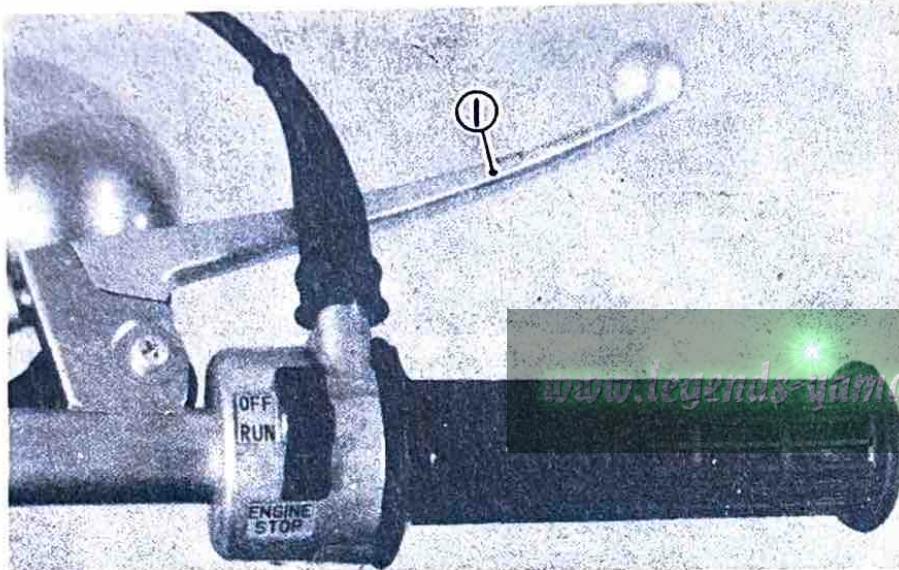

1. Front brake lever

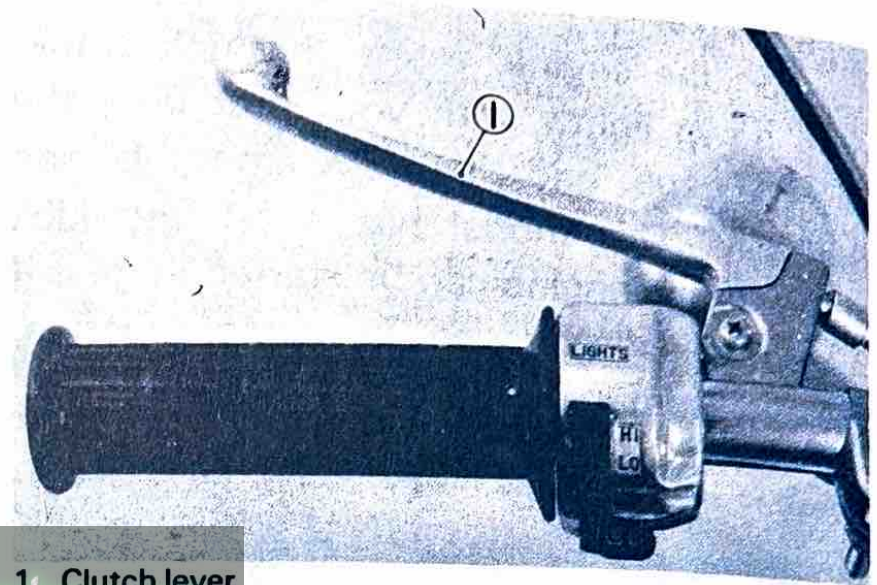

1. Clutch lever

## Clutch lever

Pull the clutch lever to the handlebar to disengage the clutch and release the lever to engage the clutch. The lever should be pulled rapidly and released slowly for smooth operation.

## Rear brake pedal

Press down on the brake pedal to activate the rear brake.

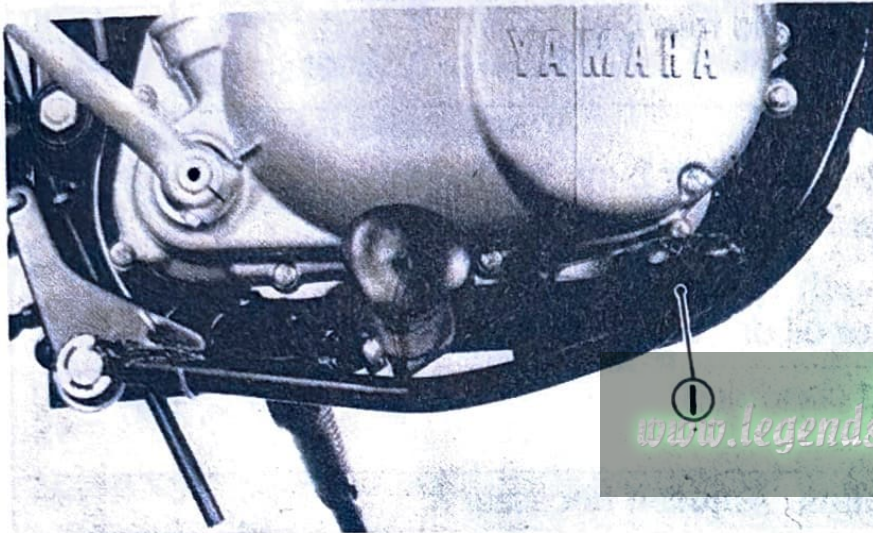

[www.legends-yamaha-enduros.com](http://www.legends-yamaha-enduros.com)

1. Rear brake pedal

## PRE-OPERATION CHECKS

Before using this motorcycle be sure to check the following points:

No.	ITEM	REMARKS	PAGE
1.	Brake (Front and Rear)	Check operation, free play. Adjust if necessary.	30 ~ 32
2.	Clutch	Check operation, condition and free play. Adjust if necessary.	32
3.	Engine Oil	Check Autolube tank oil level, top-up with Yamalube 2-cycle oil or 2-cycle oil with "BIA certified for service TC-W" if necessary.	36, 37
4.	Transmission Oil	Check oil level. Top-up with Yamalube 4-cycle oil or SAE 10W/30 "SE" motor oil or "GL" gear oil if necessary.	26, 27
5.	Drive Chain	Check chain tension and condition. Adjust if necessary.	27 ~ 30
6.	Throttle	Check for smooth operation. Adjust if necessary.	11
7.	Battery	Check fluid level, top-up with distilled water if necessary.	33 ~ 35
8.	Lights/Signals	Check operation.	11, 12
9.	Wheel/Tires	Check tire pressure, wear, damage. Check tightness of spokes.	12, 13
10.	Fittings/Fasteners	Check all chassis fittings and fasteners. Adjust if necessary.	13
11.	Fuel	Check fuel level. Add fuel if necessary.	13

### —WARNING:

**If any item on the checklist is not functioning properly, do not operate the motorcycle until the item has been inspected and repaired.**

### **Brake (Front and Rear)**

Check for correct play in the brake lever and pedal and make sure they are working properly. Check the brakes at low speed shortly after starting out. If the play is incorrect, make an adjustment.

### **Clutch**

Check for correct play in the clutch lever and make sure the lever operates properly. If the play is incorrect, make an adjustment.

### **Engine oil (oil tank)**

Make sure there is sufficient engine oil in the oil tank. Add oil as necessary.

Recommended oil:

See page 36 "Engine Oil" section

### **Transmission oil**

Make sure the transmission oil is at the specified level. Add oil as necessary.

Recommended oil:

See "GENERAL MAINTENANCE/  
LUBRICATION NO. 1" page 23.

To check level, screw the oil filler cap completely out and then just rest the dip stick in the hole.

### **Drive chain**

Check the chain tension and condition. Adjust if necessary.

### **Throttle**

Turn the throttle grip to see if it operates properly and if the play is normal. Make certain the throttle snaps closed when released. Adjust if necessary.

### **Battery**

Check the fluid level and top-up if necessary. Use only distilled water if refilling is necessary.

### **Lights/Signals**

Check the headlight, flasher light, taillight, brake light, meter lights and all the indicator

lights to make sure they are in working condition.

### Wheels/Tires

Check the tire pressure and check the tires for wear.

### IMPORTANT NOTICE

Proper loading of your motorcycle is important for the handling, braking, and other performance and safety characteristics of your machine. **NEVER OVERLOAD YOUR MOTORCYCLE.** Consider your riding skill, road and weather conditions, and correct weight distribution when loading your motorcycle. Securely pack your heaviest items close to the center of the machine. Always check the condition and inflation pressure of your tires.

### —WARNING: —

Never overload the motorcycle beyond specified tire limits. Operation of an

**overloaded tire could cause tire damage, an accident and injury.**

	FRONT	REAR
GT80F BASIC WEIGHT with oil full fuel tank	32 kg (71 lb)	37 kg (82 lb)
Standard tire	Nitto 2.50-15-4PR	Nitto 2.75-14-4PR
Tire load limit	52 kg (115 lb)	93 kg (205 lb)
Cold tire pressure OFF road riding	1.5 kg/cm <sup>2</sup> (22 psi)	2.0 kg/cm <sup>2</sup> (28 psi)
ON road riding	1.5 kg/cm <sup>2</sup> (22 psi)	2.3 kg/cm <sup>2</sup> (32 psi)
Minimum tire tread depth	0.8 mm (0.03 in)	0.8 mm (0.03 in)



TIRE WEAR INDICATOR

If a tire tread shows cross-wise lines, it means that the tire is worn to its limit.  
Replace the tire.

**WARNING:**

**It is dangerous to ride with a worn-out tire. When a tire tread begins to show lines, have your Yamaha dealer or other qualified mechanic replace the tire immediately.**

Check for wheel damage and check the tightness of the spokes.

**Fittings/Fasteners**

Always check the tightness of chassis fittings and fasteners before riding.

**Fuel**

Make sure there is sufficient fuel in the tank.

Recommended fuel:

Grade: Regular (Leaded)

Regular octane: 91 minimum

Fuel tank capacity:

4.8 liters (1.3 US gallon)

**OPERATION AND  
IMPORTANT RIDING  
POINTS**

**CAUTION:**

**Before riding this motorcycle, become thoroughly familiar with all operating controls and their function.**

**Consult your Yamaha dealer regarding any control or function you do not thoroughly understand.**

## Starting a cold engine

1. Shift transmission into neutral.
2. Turn the fuel petcock to the "ON" position.
3. Turn the ignition key to the "ON" position.
4. Turn the engine stop switch to the "RUN" position.
5. Push the starter lever down to ON, place the throttle grip in the fully closed position or a slightly opened position, and kick the kick crank briskly.
6. After the engine has started, turn the throttle grip so that the engine idles.

7. After the recommended number of seconds\*, pull up the starter lever to OFF.

**NOTE:** \_\_\_\_\_

You may start out by operating throttle grip within recommended seconds.

---

\* Recommended seconds for the starter operation.

Above 20°C	Approx. 5 sec.
20°C — 10°C	5 sec. — 20 sec.
10°C	Approx. 20 sec.
10°C — 0°C	20 sec. — 60 sec.
Below 0°C	Approx. 60 sec.

Adjust the duration of time for using the starter according to ambient temperatures.

## Starting a warm engine.

To start a warm engine, the starter lever is not required.

## Warming up

To get maximum engine life, always “warm-up” the engine before riding the machine. Never accelerate hard with a cold engine!

### CAUTION:

See “Break-in Section” prior to operating engine for the first time.

## Engine break-in

There is never a more important period in the life of your motorcycle, than the period between zero and 800 km (500 mi). For this reason we ask that you carefully read the following material. Because the engine is brand new, you must not put an excessive load on it for the first several hours of running. During the first 400 km (250 mi) the various parts in the engine wear and polish themselves to the correct operating

clearances. During this period prolonged full throttle operation, or any condition which might result in excessive heating of cylinder, must be avoided.

If any abnormality is noticed during this period, ask your Yamaha dealer to check.

### CAUTION:

If any engine trouble should occur during the break-in period, consult your Yamaha dealer immediately.

### 1. 0 ~ 160 km (0 ~ 100 mi):

Avoid operation above 40 km/h (25mi/h) in 4th gear. Allow a cooling off period of 5 to 10 minutes after every hour of operation. Vary the speed of the motorcycle from time to time. Do not operate it at one constant throttle position.

### 2. 160 ~ 400 km (100 ~ 250 mi):

Avoid prolonged operation above 40 km/h (25 mi/h) in 4th gear. Allow the

motorcycle to rev freely through the gears but do not use full throttle at any time.

3. 400 ~ 800 km (250 ~ 500 mi):  
Avoid prolonged full throttle operation.  
Avoid cruising speeds in excess of 50 km/h (31 mi/h) in 4th gear.
4. 800 km (500 mi) and beyond:  
Avoid prolonged full throttle operation.  
Vary speeds occasionally.

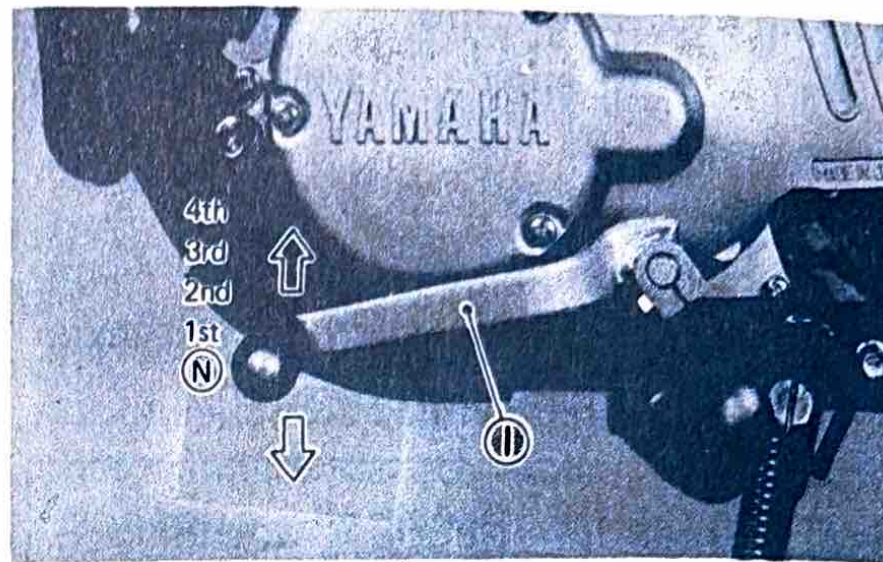

1. Change pedal N. Neutral

[www.legends-yamaha-enduros.com](http://www.legends-yamaha-enduros.com)

### Shifting and acceleration

This model has a 4-speed transmission. The transmission allows you to control the amount of power you have available at a given speed for starting accelerating, climbing hills, etc. To shift into NEUTRAL, repeatedly depress the change pedal to the end of its travel. (You will feel a stop when you are in neutral.)

### To start out and accelerate:

1. Pull the clutch lever to disengage the clutch.
2. Shift into FIRST gear.
3. Open the throttle gradually, and at the same time, release the clutch lever slowly.
4. At the recommended shift point speed in the table below, close the throttle, and at the same time, pull in the clutch lever quickly.

5. Shift into **SECOND** gear.
6. Open the throttle part way and gradually release the clutch lever.
7. To accelerate, use the same procedure to shift into the next higher gear according to the Recommended Shift Point Chart below.

\*To decelerate

1. Apply front and/or rear brakes to slow the machine.
2. When the machine reaches 20 km/h (12.5 mi/h), shift into the lower gear.
3. When the machine is almost completely stopped shift to neutral.

### Recommended Shift Point

	Acceleration km/h (mph)	Deceleration* km/h (mph)
1st — 2nd	20 (12)	20 (12)
2nd — 3rd	30 (18)	20 (12)
3rd — 4th	40 (24)	20 (12)

### Crusing

A frequently asked question is "What speed should I cruise at?". The **BREAK-IN** section provides limitations when the motorcycle is new, but once the engine has been broken in, then we suggest that you follow these guide lines: For sustained load and throttle conditions, such as those encountered on open highways, cruise at 3/4 throttle. Always bear in mind, though, the maximum allowable speed limit for the area through which you are riding. This is a recommendation, not a "hard and fast" rule. Any modification or personalization of the running gear could possible change the operating range most comfortable and most efficient for the engine.

### Parking

When parking, stop the engine and remove the ignition key. Make it a habit to turn the fuel petcock to "OFF" whenever stopping the engine.

**NOTE:** \_\_\_\_\_

Select a parking place where the motorcycle is not apt to fall.

---

## PERIODIC MAINTENANCE AND MINOR REPAIR

Periodic inspection, adjustment and lubrication will keep your motorcycle in the safest and most efficient condition possible. Safety is an obligation of the motorcycle owner. The most important points of motorcycle inspection, adjustment and lubrication are explained on the following pages.

**CAUTION:** \_\_\_\_\_

If the owner is not familiar with motorcycle service, this work should be done by a Yamaha dealer or a qualified mechanic.

### Tool Kit

The servicing information included in this manual is intended to provide you, the owner, with the necessary information for completing some of your own preventive maintenance and minor repairs. The tools provided in the owner's tool kit are sufficient for this purpose, except that a torque wrench is also necessary to properly tighten nuts and bolts.

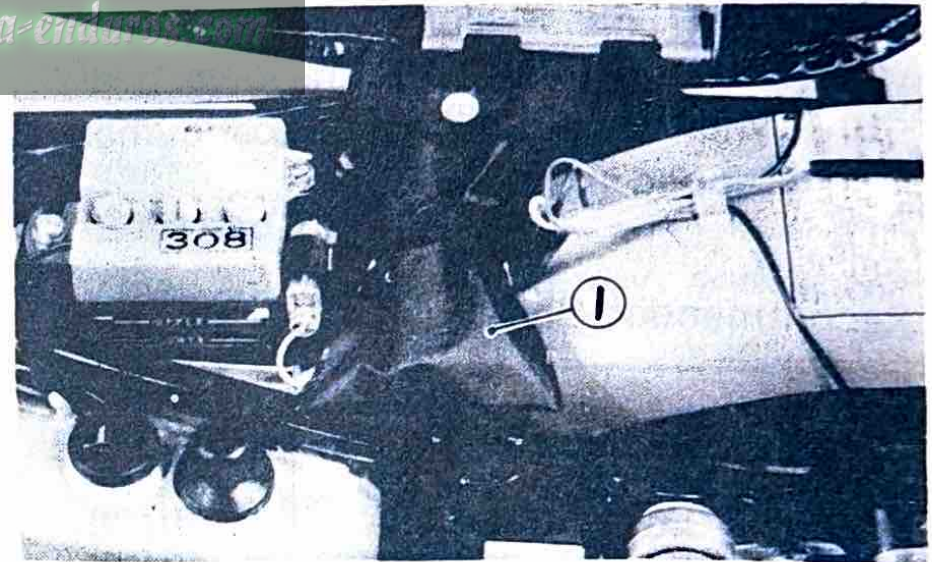

1. Tool kit

## **PERIODIC MAINTENANCE**

PROPER PERIODIC MAINTENANCE OF YOUR MOTORCYCLE IS IMPORTANT TO ITS GIVING YOU LONG, PLEASURABLE SERVICE. ESPECIALLY IMPORTANT ARE THE MAINTENANCE SERVICES RELATED TO EMISSIONS CONTROL. THESE CONTROLS NOT ONLY FUNCTION TO ENSURE CLEANER AIR BUT ARE ALSO VITAL TO PROPER ENGINE OPERATION AND MAXIMUM PERFORMANCE. IN THE FOLLOWING TABLES OF PERIODIC MAINTENANCE, THE SERVICES RELATED TO EMISSIONS CONTROL ARE GROUPED SEPARATELY.

THESE SERVICES REQUIRE SPECIALIZED DATA, KNOWLEDGE, AND EQUIPMENT. YAMAHA DEALERS ARE TRAINED AND EQUIPPED TO PERFORM THESE PARTICULAR SERVICES.

## PERIODIC MAINTENANCE EMISSION CONTROL SYSTEM

No.	ITEM	REMARKS	INITIAL BREAK-IN		THEREAFT- ER EVERY
			1,000 km or 1 month (600 mi)	4,000 km or 7 months (2,500 mi)	3,000 km or 6 months (2,000 mi)
1.	Ignition Timing*	Check and clean contact breaker point. Check ignition timing. Replace points if necessary. Check point cam wick. Apply oil if necessary.	○	○	○
2.	Spark Plug	Check spark plug condition and plug gap. Replace plug every 3,000 km (2,000 mi).	○	○ Replace	○ Replace
3.	Fuel Hose*	Check fuel hose for cracks and damage. Replace if necessary.	○	○	○
4.	Fuel Petcock*	Check fuel petcock for proper function.	○	○	○
5.	Idle Speed*	Check and adjust engine idle speed. Adjust cable free play.	○	○	○
6.	Exhaust System*	Retighten exhaust system connections.	○	○	○

\* It is recommended that these items be inspected and adjusted by a qualified mechanic such as your Yamaha dealer.

## Spark plug inspection

The spark plug is an important engine component and is easy to inspect.

You should periodically remove and inspect the spark plug because heat and deposits will cause any spark plug to slowly break down and erode. If electrode erosion becomes excessive, or if carbon and other deposits are excessive, you should replace the spark plug with one of the proper type.

The condition of the spark plug reflects the running condition of the engine. For example, a very white center electrode porcelain color could indicate an intake tract air leak or carburetion problem.

Do not attempt diagnose such problems yourself. Instead, take the machine to your Yamaha dealer or a qualified mechanic.

Standard spark plug:  
B7HS (NGK)

Before installing any spark plug, measure the plug gap with a wire thickness gauge and adjust to specifications.

Spark plug gap:  
0.5 ~ 0.7 mm (0.020 ~ 0.028 in)

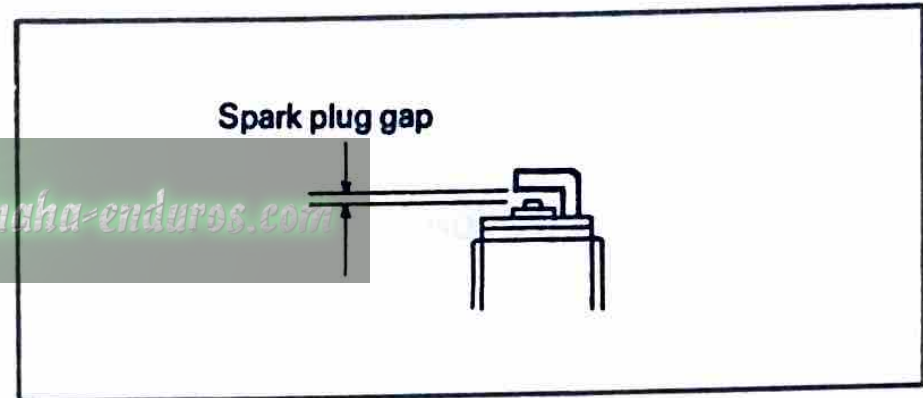

When installing the plug, always clean the gasket surface. Wipe off any grime from the threads and torque the spark plug properly.

Tightening torque:  
2.5 m·kg (18 ft·lb)

## ANTICIPATED MAINTENANCE

The maintenance items in this table are set apart from the regular periodic maintenance items because of their anticipated need for irregular service intervals. The service interval is dependent upon variable factors such as the severity of use, operating conditions, etc. Therefore, perform this maintenance when the described symptoms warrant it.

No.	ITEM	REMARKS
1	Spark Plug	If any spark plug failure is noticed replace the spark plug. Symptoms indicating spark plug failure are anticipated to occur around 3,000 km (2,000 mi).
2*	Decarbonization	If heavy power loss is evident, decarbonize the cylinder head, piston head and exhaust system. Carbon build-up is anticipated to occur around 5,000 ~ 10,000 km (3,000 ~ 6,000 mi).
3*	Piston	If the piston rattles, the vehicle becomes hard to start, appears to be lacking power, or becomes inoperative, repair as follows: replace the piston and piston rings, clean, hone, or replace the cylinder. These symptoms are anticipated to occur mainly below 500 km (300 mi).

\*It is recommended that these items be serviced by a qualified mechanic such as your Yamaha dealer.

## GENERAL MAINTENANCE/LUBRICATION

No.	ITEM	REMARKS	TYPE	INITIAL BREAK-IN		THEREAFTER EVERY	
				1,000 km or 1 month (600 mi)	4,000 km or 7 months (2,500 mi)	3,000 km or 6 months (2,000 mi)	15,000 km or 24 months (9,500 mi)
1.	Transmission Oil	Warm-up engine before draining.	Yamalube 4-cycle oil or SAE 10w/30 "SE" motor oil or "GL" gear oil	○	○	○	
2.	Drive Chain	Adjust chain tension and lubricate thoroughly.	Yamaha chain and cable lube or SAE 10w/30 motor oil	○	○	○	
3.	Brake System	Inspect and adjust. Replace shoes if necessary.	—	○	○	○	
4.	Clutch*	Adjust free play.	—	○	○	○	
5.	Control and Meter Cables	Inspect and lubricate thoroughly.	Yamaha chain and cable lube or SAE 10w/30 motor oil	○	○	○	
6.	Throttle* Cable	Adjust as necessary. Lightly lubricate.	Lithium base grease		○	○	
7.	Brake and Clutch Pivot Shaft	Lubricate. Apply lightly.	Yamaha chain and cable lube or SAE 10w/30 motor oil		○	○	
8.	Side Stand Shaft Pivot	Lubricate. Apply lightly.	Yamaha chain and cable lube or SAE 10w/30 motor oil		○	○	
9.	Front Fork Oil	Drain completely. Fill to specification.	Yamaha fork oil 10wt or equivalent				○
10.	Steering Ball Bearings and Races*	Check steering assembly for looseness. Moderately repack every 15,000 km (9,500 mi).	Medium weight wheel bearing grease		○		○

No.	ITEM	REMARKS	TYPE	INITIAL BREAK-IN		THEREAFTER EVERY	
				1,000 km or 1 month (600 mi)	4,000 km or 7 months (2,500 mi)	3,000 km or 6 months (2,000 mi)	15,000 km or 24 months (9,500 mi)
11.	Wheel* Bearings	Check bearings for smooth rotation. Moderately repack every 15,000 km (9,500 mi).	Medium weight wheel bearing grease		○		○
12.	Battery	Check specific gravity.	—		○	○	
13.	Autolube* Pump	Check and adjust pump cable and minimum pump stroke.	—	○	○	○	
14.	Air Filter	Check for clogging. If necessary, clean and dampen with oil.	—	○	○	○	

\*It is recommended that these items be serviced by a qualified mechanic such as your Yamaha dealer.

[www.legends-yamaha-enduros.com](http://www.legends-yamaha-enduros.com)

## Torque specifications

(For a more complete list, refer to the Service Manual for this model.)

Use a torque wrench to tighten these items. It is recommended that these items be checked

Item	Torque
Spark plug	2.5 m-kG (18.0 ft-lb)
Kick crank	1.2 m-kG ( 8.6 ft-lb)
Change pedal	1.0 m-kG ( 7.0 ft-lb)
Drain plug	2.0 m-kG (14.0 ft-lb)
Engine mount bolt	2.5 m-kG (18.0 ft-lb)
Handle crown-steering	3.0 m-kG (22.0 ft-lb)
Handle holder	1.2 m-kG ( 8.6 ft-lb)
Rear shock absorber	3.0 m-kG (22.0 ft-lb)
Front wheel axle	4.0 m-kG (29.0 ft-lb)
Rear wheel axle	6.0 m-kG (43.0 ft-lb)
Tension bar-Brake plate	1.8 m-kG (13.0 ft-lb)

occasionally, especially before a long tour. Always check the tightness of these items whenever they are loosened for any reason.

A (Nut)	B (Bolt)	General Torque Specifications	
		m-kG	ft-lb
10 mm	6 mm	1.0	7.2
12 mm	8 mm	2.0	15.0
14 mm	10 mm	4.0	29.0
17 mm	12 mm	4.5	33.0
19 mm	14 mm	5.0	36.0
22 mm	16 mm	6.5	47.0
24 mm	18 mm	7.0	50.0
27 mm	20 mm	8.0	58.0

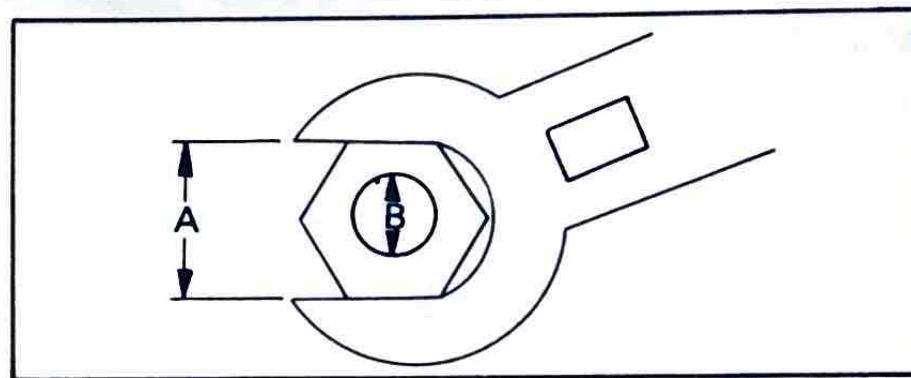

## Transmission oil

The only servicing for you to do is to check and fill the transmission with lubricating oil. To check the level, warm the engine up for several minutes, remove the oil filler cap and then just set the dip stick in the hole.

### NOTE:

Also, be sure the machine is positioned straight up and on both wheels.

The oil level should show between the Maximum and Minimum marks on the dipstick.

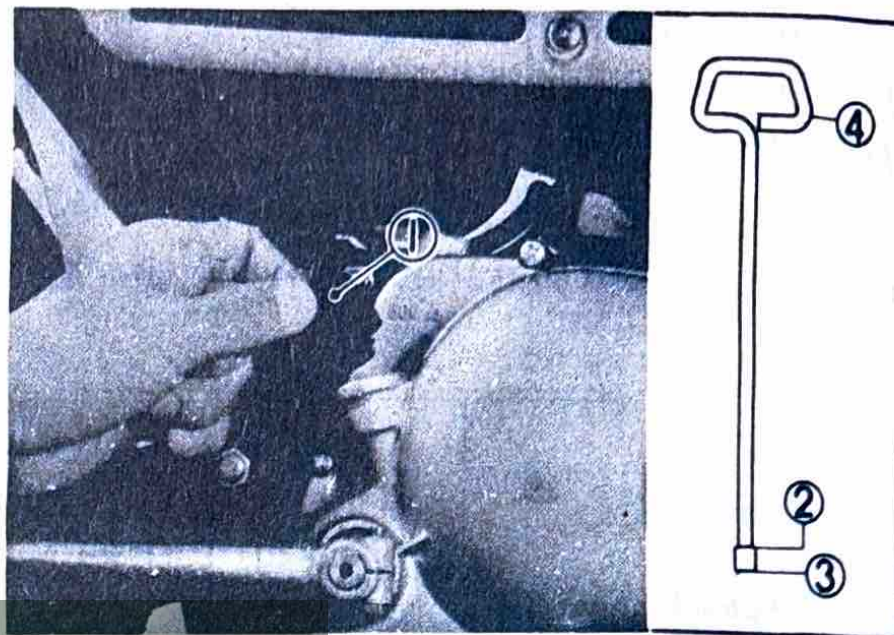

1. Oil filler cap
2. Maximum level
3. Minimum level
4. Dip stick

If the level is lower, then add sufficient oil to raise it to the proper level.

### Recommended oil:

Yamalube 4-cycle oil or SAE 10W/30 type "SE" motor oil or "GL" gear oil

During the break-in period, you should replace the transmission oil 1 month or 1,000

km (600 mi) and 7 months or 4,000 km (2,500 mi) after the date of first use.

The transmission should be drained and refilled approximately every 3,000 km (2,000 mi) or 6 months.

Oil quantity: 550 cc (18.6 US oz)

To drain the oil, warm the engine up and remove the drain plug and drain all transmission oil out.

Reinstall the drain plug (make sure it is secure). Add oil through the dip stick hole.

### Drive chain tension check

Inspect the drive chain with both tires touching the ground. Check the tension at the position shown in the illustration. The normal vertical deflection is approximately 20 ~ 30 mm. (0.8 ~ 1.2 in.). If the deflection exceeds 30 mm. (1.2 in.) adjust the chain tension.

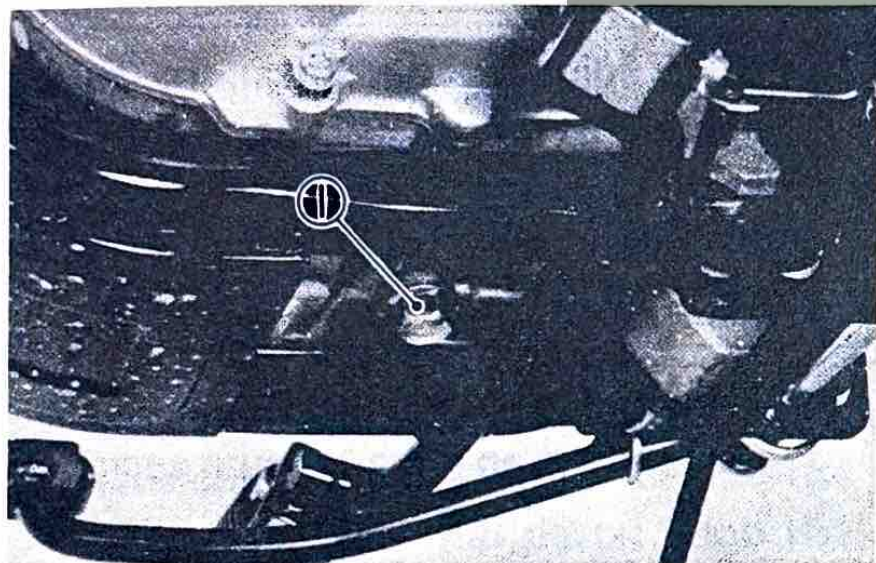

1. Drain plug



## Drive chain tension adjustment

1. Loosen the rear brake rod adjuster.
2. Remove the cotter pin from the rear wheel axle nut.
3. Loosen the rear wheel axle nut.

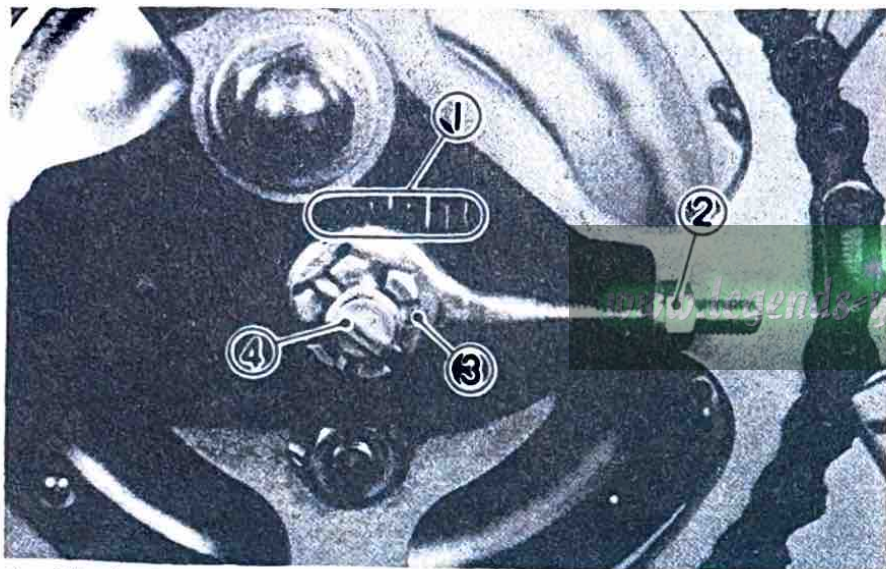

- |                        |                        |
|------------------------|------------------------|
| 1. Marks for alignment | 3. Rear wheel axle nut |
| 2. Adjuster            | 4. Cotter pin          |

4. To tighten the chain turn the chain puller adjuster nuts clockwise. To loosen the chain, turn the adjuster nuts counterclockwise and push the wheel forward. Turn each nut exactly the same

amount to maintain correct axle alignment (There are marks on each side of the rear arm and on each chain puller; use them to check for proper alignment).

### NOTE:

Before adjusting, rotate the rear wheel through several revolutions and check tension several times to find the tightest point. Adjust the chain tension with the rear wheel in this "tight chain" position.

5. After adjusting the chain, be sure to tighten the rear wheel axle nut.

**Tightening torque:**  
**6.0 m-kg (43 ft-lb)**

6. Then tighten the adjuster nuts against the rear arm an extra 1/4 turn each.

7. Insert the cotter pin into the rear wheel axle nut and bend the cotter pin end as shown in the illustration (if the nut notch and the cotter pin hole do not match, tighten the nut slightly to match).

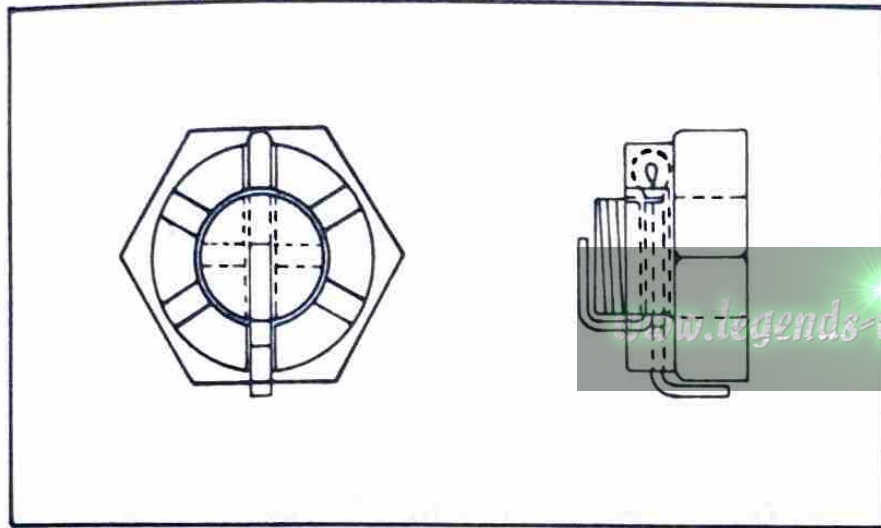

8. In the final step, adjust the play in the brake pedal.

**CAUTION:**

**Do not overtighten the chain. Excessive chain tension will overload the engine and other vital parts; keep the**

**tension within the specified limits. Also, replace the rear axle cotter pin with a new one.**

### **Drive chain lubrication**

The chain consists of many moving parts. If the chain is not maintained properly, it will wear out rapidly. Without lubrication the chain could wear out very quickly. Therefore, form the habit of periodically servicing the chain. This service is especially necessary when riding in dusty conditions.

1. Use YAMAHA CHAIN/CABLE LUBE or any of the many brands of spray type chain lubricant. First, remove dirt and mud from the chain with a brush or cloth and then spray the lubricant between both rows of side plates and on all center rollers. This should be performed at prescribed intervals or whenever the chain becomes dry.

2. To clean the entire chain, first remove the chain from the motorcycle, dip it in solvent and clean out as much dirt as possible. Then take the chain out of the solvent and dry it. After drying, lubricate the chain to prevent the formation of rust.

### Front brake adjustment

Front brake should be adjusted to suit rider preference with a minimum cable slack of 5 ~ 8 mm (0.2 ~ 0.32 in) play at the brake lever pivot point.

1. Loosen the adjuster lock nut.
2. Turn the cable length adjuster in or out until adjustment is suitable.
3. Tighten the adjuster lock nut.

When it is impossible to make the proper adjustment at the brake lever, ask for further adjustment at the brake shoe plate.

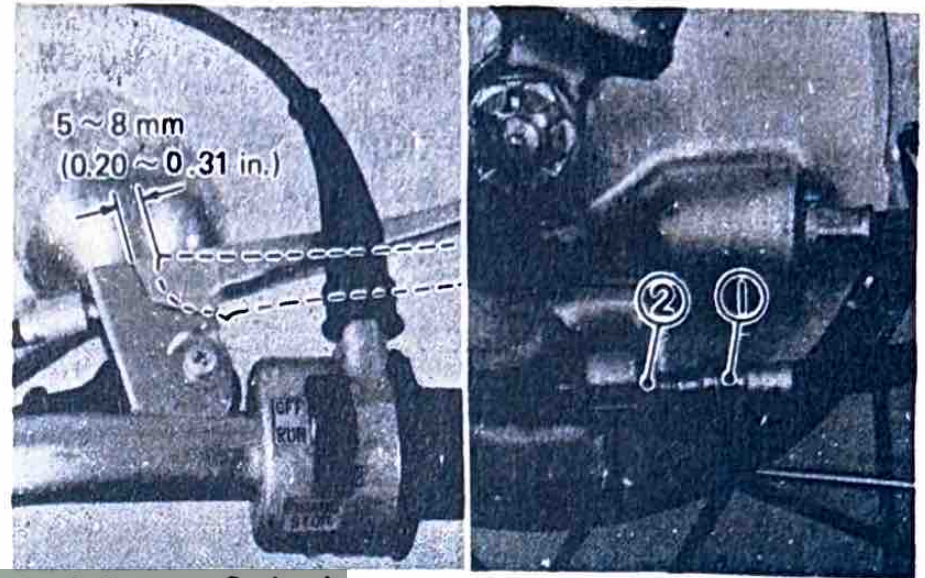

1. Adjuster 2. Lock nut

### Rear brake adjustment

The rear brake should be adjusted so the end of the brake pedal moves 20 ~ 30 mm (0.79 ~ 1.18 in). To adjust, turn the adjuster on the brake rod clockwise to reduce play; turn the adjuster counterclockwise to increase play. Check whether or not the brakelight operates correctly after adjusting.

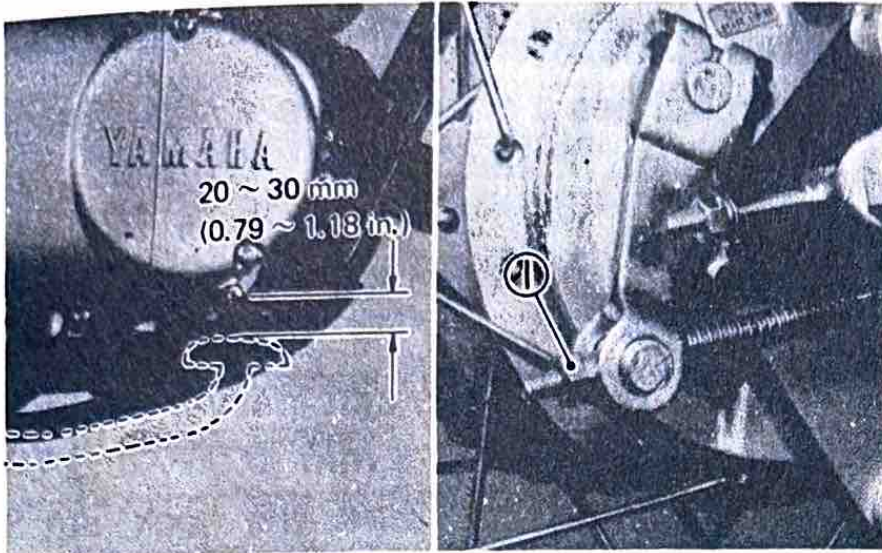

1. Adjuster

**CAUTION:**

Always check whether or not the brakelight operates correctly after rear brake adjustment.

**Brake lining inspection**

The specified thickness of the brake lining when new is 4 mm (0.16 in). The lining should be replaced when the brake lining material wears to less than 2 mm (0.079 in) thickness. To inspect, remove the plug from the in-

spection hole on the brake shoe plate and check the thickness of the lining. If worn out, ask your Yamaha dealer to install a new set of brake shoes. Be sure to replace the plug properly so water cannot enter the shoe plate.

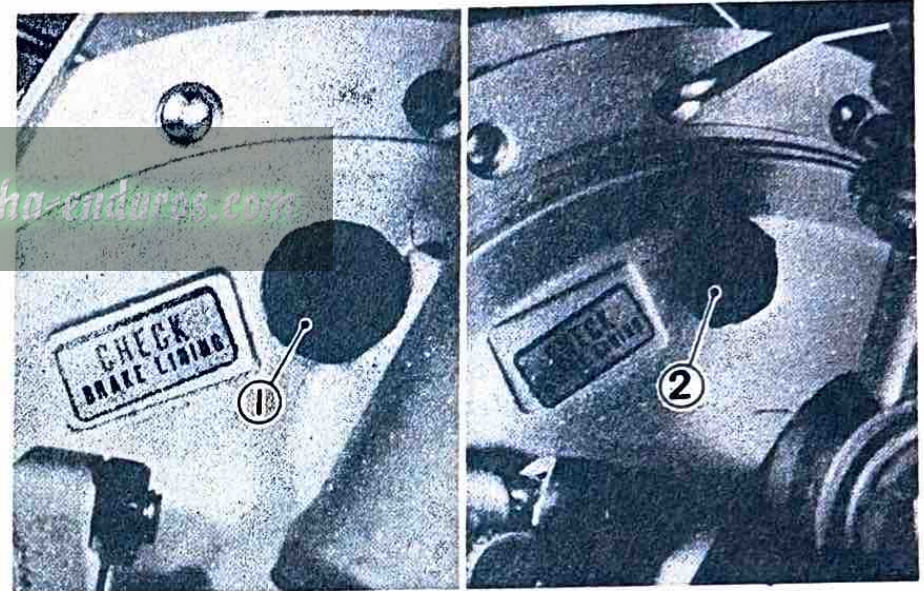

1. Inspection hole (Front)  
2. Inspection hole (Rear)

## Brakelight switch adjustment

The brakelight switch is operated by movement of the brake pedal. To adjust, loosen the lock nut and rotate the adjusting nut. Proper adjustment is achieved when the brake starts to take effect and the brakelight illuminates simultaneously. After adjusting, tighten the lock nut.

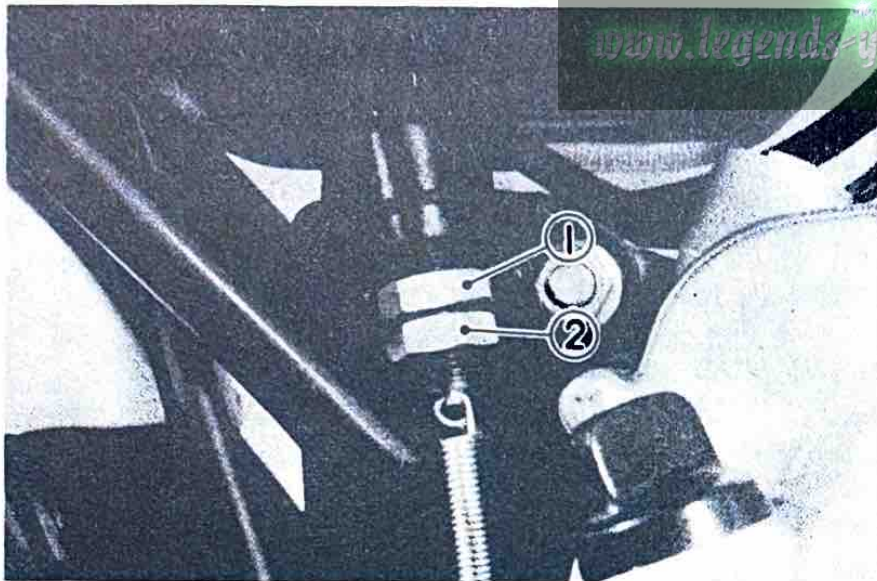

1. Adjusting nut 2. Lock nut

## Clutch adjustment

This model has a clutch cable length adjuster and a clutch mechanism adjuster. Adjustment at the clutch lever is normally recommended. Loosen the lock nut and turn the adjuster to adjust the clutch lever. The clearance between the clutch lever and lever holder should be 2 ~ 3 mm (0.08 ~ 0.12 in.). After adjusting, be sure the lock nut is tightened firmly. When it is impossible to make an adjustment at the case cover, ask a Yamaha dealer or other qualified mechanic to adjust the internal mechanism.

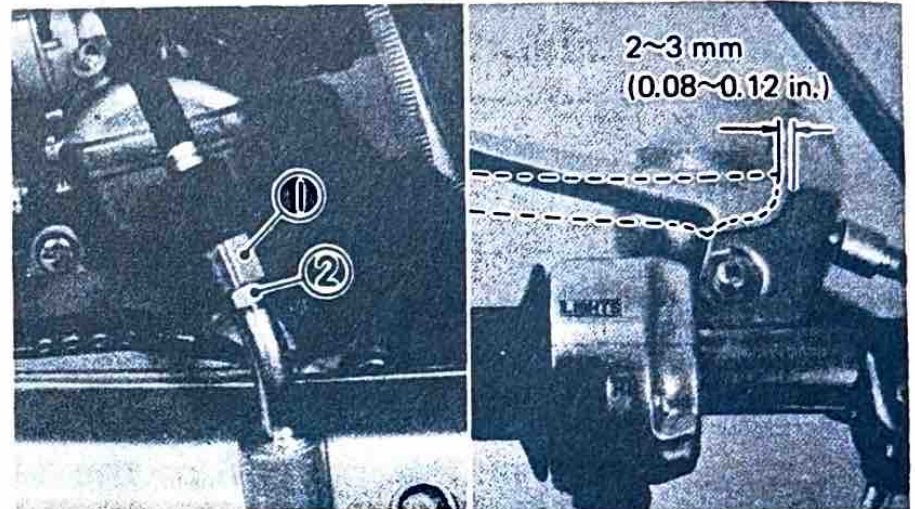

1. Adjusting nut 2. Lock nut

## Cable inspection and lubrication

### WARNING:

Damage to the outer housing of the various cables may cause corrosion and often free movement will be obstructed. An unsafe condition may result so replace damaged cables as soon as possible.

If the inner cables do not operate smoothly, lubricate them. If necessary, have them replaced.

### Recommended lubricant:

YAMAHA Chain and Cable Lube or  
SAE 10W/30 motor oil

## Inspection and adjustment of play in throttle cable

Check free play in the throttle grip. The play should be 3 ~ 5 mm (0.12 ~ 0.20 in) at the grip flange. Loosen the lock nut and turn the

wire adjuster to make the necessary adjustment. After adjusting, be sure to tighten the lock nut properly.

### NOTE:

To adjust throttle cable freeplay, the handlebars should be turned fully to the right.

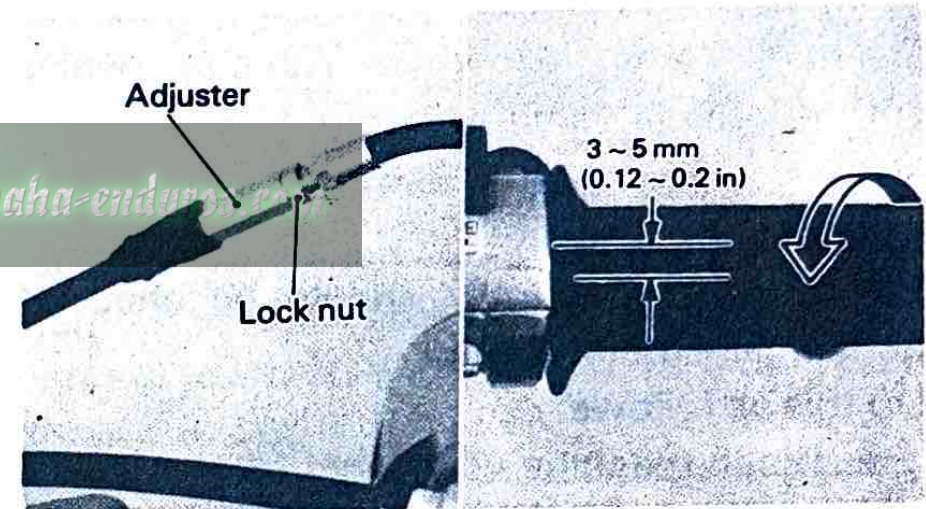

## Brake and Clutch Levers

Lightly lubricate the brake and clutch pivot points with Yamaha Chain and Cable Lube or 10W/30 motor oil.

## Side Stand Shaft Pivot

Lubricate the side stand pivot point with Yamaha Chain and Cable Lube or 10W/30 motor oil.

## Front Fork Oil Change

The front fork oil should be changed according to the General maintenance schedule. It is recommended that a qualified mechanic such as your Yamaha dealer perform this service.

## Steering Assembly

The steering assembly should be checked periodically for looseness.

Do this as follows:

- a. Block machine up so that front wheel is off the ground.
- b. Grasp bottom of the forks and gently rock the front assembly backward and forward, checking for looseness in the steering assembly bearings.

If any looseness is noted, or if the handlebars

will not turn freely have your Yamaha dealer or other qualified mechanic adjust the steering mechanism.

## Wheel Bearings

Check the wheel bearings for smooth rotation. There should be no rough spot or side movement. Have the wheel bearings repacked with grease at the specified service intervals.

## Battery

Check the level of the battery fluid and see if the terminals are tight. Add distilled water if the fluid level is low.

### **—WARNING:**

**Battery fluid is poisonous and dangerous, causing severe burns, etc. Contains sulfuric acid. Avoid contact with skin, eyes or clothing.**

**Antidote: EXTERNAL-FLUSH with water. INTERNAL-Drink large quantities of water or milk. Follow with milk of magnesia, beaten egg or**

vegetable oil. Call physician immediately.

**Eyes:** Flush with water for 15 minutes and get prompt medical attention. Batteries produce explosive gases. Keep sparks, flame, cigarettes, etc., away. Ventilate when charging or using in enclosed space. Always shield eyes when working near batteries. **KEEP OUT OF REACH OF CHILDREN.**

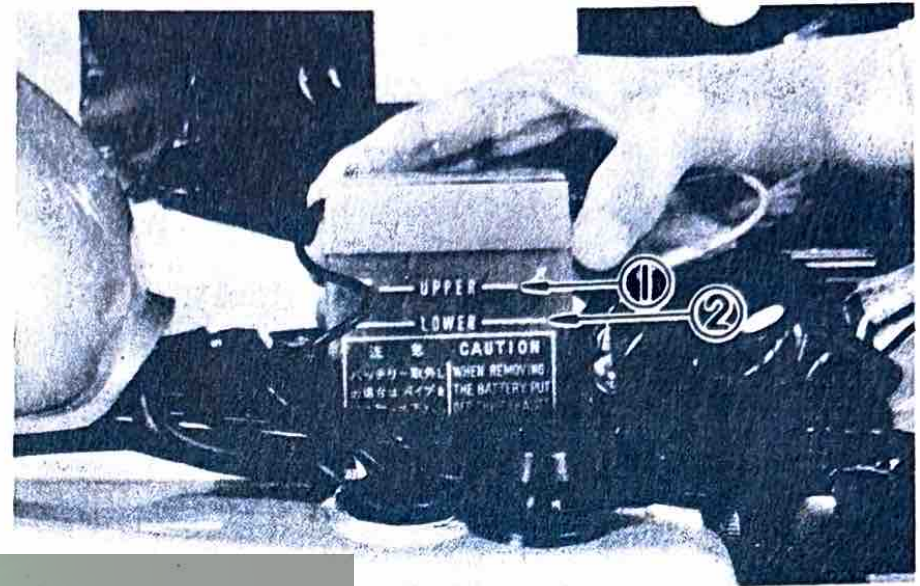

1. Upper level    2. Lower level

### Replenishing the battery fluid

A poorly maintained battery will deteriorate quickly. The battery fluid should be checked at least once a month.

1. The level should be between the upper and lower level marks. Use only distilled water if refilling is necessary.

### NOTE:

Normal tap water contains minerals which are harmful to a battery; therefore, refill only with distilled water.

2. When the motorcycle is not to be used for a month or longer, remove the battery and store it in a cool, dark place. Completely recharge the battery before reusing.

3. If the battery is to be stored for a longer period than the above, check the specific gravity of the fluid at least once a month and recharge the battery when it is too low.
4. Always make sure the connections are correct when putting the battery back in the motorcycle. The red lead is for the + terminal and the black lead is for the - terminal. Make sure the breather pipe is properly connected and is not damaged or obstructed.

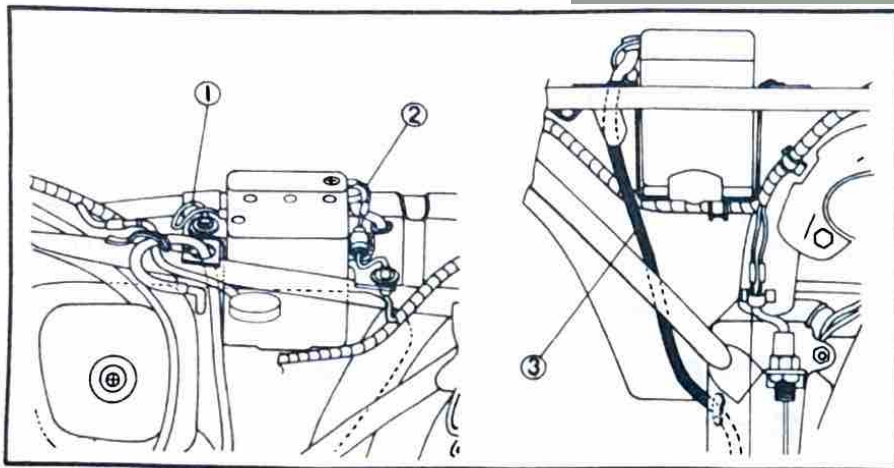

1 Battery - lead wire  
2 Battery + lead wire

3 Battery breather pipe

### Autolube pump

Have your Yamaha dealer check and adjust the oil injection pump cable and the pump stroke. Be sure your oil tank never runs out of oil. If it does, before operating your machine, have your dealer bleed all the air out of the oil injection system.

#### WARNING:

Failure to bleed the injection system could result in extensive engine damage and an accident.

### Engine oil

We recommended Yamalube 2-cycle oil (available at most Yamaha dealers) or if unavailable, 2-cycle engine oil labelled "BIA certified for service TC-W".

#### NOTE:

Oil viscosity increases in very cold weather (where the normal temperature is below 0°C (32°F) ) and oil does not flow as well. In such areas, consult your Yamaha dealer.

Oil tank capacity:  
0.7 lit (0.74 US qt)

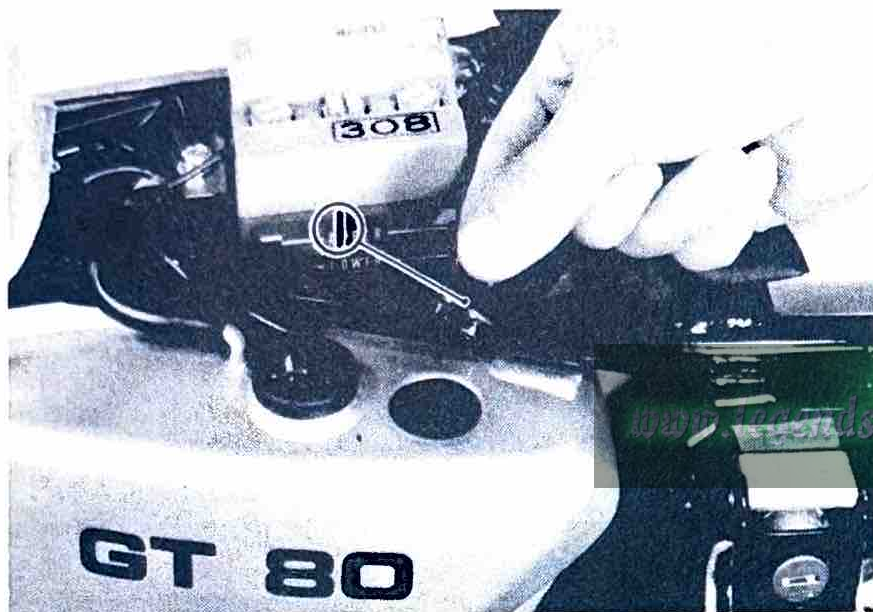

1. Oil tank filler cap

**NOTE:**

Install the oil tank filler cap and push it fully into the filler.

**Air cleaner**

Have the air cleaner element cleaned at the specified intervals.

**CARBURETOR ADJUSTMENT:**

The carburetor is a vital part of the engine and its emission control system. Adjusting should be left to a Yamaha dealer or other qualified mechanic with the professional knowledge, specialized data and equipment to do so properly.

## Troubleshooting

Although Yamaha motorcycles are given a rigid inspection before shipment from the factory, trouble may occur during operation. If this happens, check the motorcycle in accordance with the procedures given in the chart below. If repair is necessary, ask a qualified mechanic such as your Yamaha dealer for assistance. The skilled technicians at your Yamaha dealer are trained and equipped to perform the necessary maintenance and repair work. For replacement parts, Yamaha recommends you use Genuine Yamaha Parts, or parts you know are equivalent in quality.

Any fault in the fuel, compression or ignition system can cause poor starting, excessive emissions, engine damage, or loss of power while riding. The troubleshooting chart describes a quick and easy series of system checks to locate the problem.

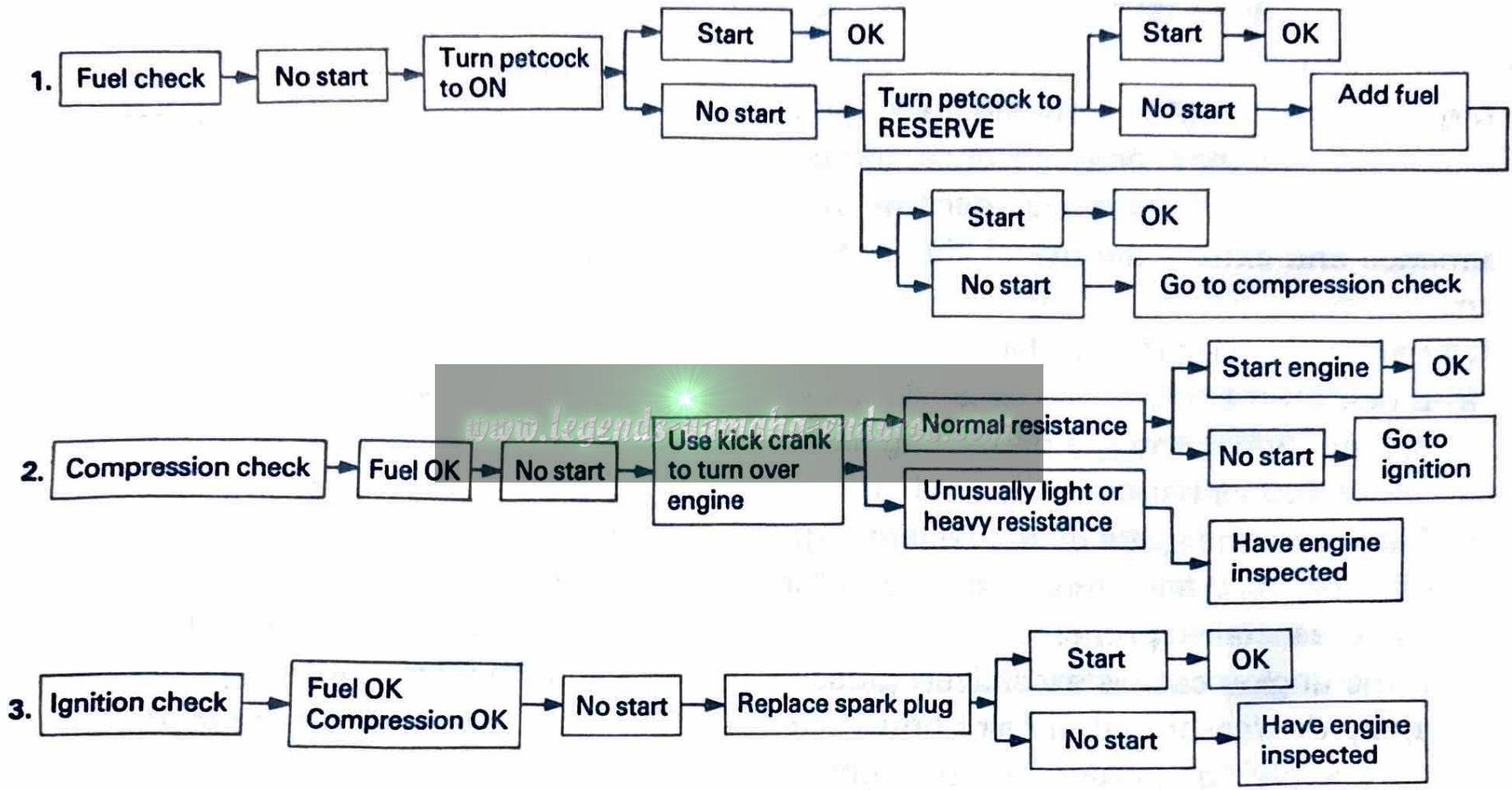

# CLEANING AND STORAGE

## A. CLEANING

Frequent thorough cleaning of your motorcycle will not only enhance its appearance but will improve general performance and extend the useful life of many components.

1. Before cleaning the machine:
  - a. Block off the end of the exhaust pipe to prevent water entry; a plastic bag and a strong rubber band may be used.
  - b. Make sure the spark plug, fuel tank cap, oil tank cap, and transmission oil filler cap are installed properly.
2. If the engine case is excessively greasy, apply degreaser with a paint brush. Do not apply degreaser to the chain, sprockets, or wheel axles.

3. Rinse the dirt and degreaser off with a garden hose, using only enough hose pressure to do the job.

### CAUTION:

Excessive hose pressure may cause water seepage and contamination of wheel bearings, front forks, brake drums, and transmission seals. Many expensive repair bills have resulted from improper applications of high pressure detergents.

4. Once the majority of the dirt has been hosed off, wash all surfaces with warm water and mild, detergent-type soap. An old tooth brush or bottle brush is handy to reach hard-to-get-to places.
5. Rinse machine off immediately with clean water and dry all its surfaces with compressed air, a chamois, clean towel, or soft absorbent cloth.

6. Chrome-plated parts such as handlebars, rims, spokes, forks, etc., may be further cleaned with automotive chrome cleaner.
7. Clean the seat with a vinyl upholstery cleaner to keep the cover pliable and glossy.
8. Automotive-type wax may be applied to all painted and chrome-plated surfaces. Avoid combination cleaner-waxes. Many contain abrasives which may mar the paint or protective finish on the fuel and oil tanks.
9. After finishing, start the engine immediately and allow to idle for several minutes to dry it off completely.

## **B. STORAGE**

Long term storage (30 days or more) of your motorcycle will require some preventive procedures to insure against deterioration. After cleaning the machine thoroughly, prepare it for storage as follows:

1. Drain the fuel tank, fuel lines, and carburetor float bowl.
2. Remove empty fuel tank, pour a cup of 10W to 30W oil in tank, shake tank to coat inner surfaces thoroughly and drain off excess oil. Re-install tank.
3. Remove the spark plug, pour about one tablespoon of 10W to 30W oil in to the spark plug hole, and re-install the spark plug. Kick the engine over several times (with ignition off) to coat cylinder walls with oil.
4. Lubricate all control cables.
5. Block up the frame to raise both wheels off ground.

6. Tie a plastic bag over the exhaust pipe outlet to prevent moisture from entering.
7. If storing in humid or salt-air atmosphere, coat all exposed metal surfaces with a light film of oil. Do not apply oil to rubber parts or cover.

Remove the battery and charge it. Store it in a dry place and re-charge it once a month. Do not store the battery in an excessively warm or cold place (less than 0°C (32°F) or more than 30°C (90°F) ).

**NOTE:** \_\_\_\_\_  
Make any necessary repairs before storing the motorcycle.  
\_\_\_\_\_

# MISCELLANEOUS

## Consumer information

### STOPPING DISTANCE

This figure indicates braking performance that can be met or exceeded by the vehicles to which it applies, without locking the wheels, under different conditions of loading and with partial failures of the braking system. The information presented represents results obtainable by skilled drivers under controlled road and vehicle conditions and the information may not be correct under other conditions.

Description of vehicles to which this table applies: Yamaha motorcycle GT80F

[www.legends-yamaha-enduros.com](http://www.legends-yamaha-enduros.com)

#### A. Fully Operational Service Brake

Load

Light

Maximum

86

99

0

100

200

300 (Feet)

**NOTE:** The statement above is required by U.S. Federal law. "Partial failures" of the braking system do not apply to this chart.

Stopping distance in feet from 50 mi/h

# ACCELERATION AND PASSING ABILITY

This figure indicates passing times and distances that can be met or exceeded by the vehicles to which it applies, in the situations diagrammed below.

The low-speed pass assumes an initial speed of 20 mi/h and a limiting speed of 35 mi/h. The high-speed pass assumes an initial speed of 50 mi/h and a limiting speed of 80 mi/h.

**NOTICE:** The information presented represents results obtainable by skilled drivers under controlled road and vehicle conditions, and the information may not be correct under other conditions.

Description of vehicles to which this table applies: Yamaha motorcycle GT80F

## Summary table

Low-speed pass . . . . .	417 feet:	9.3 seconds
High-speed pass . . . . .		Not capable

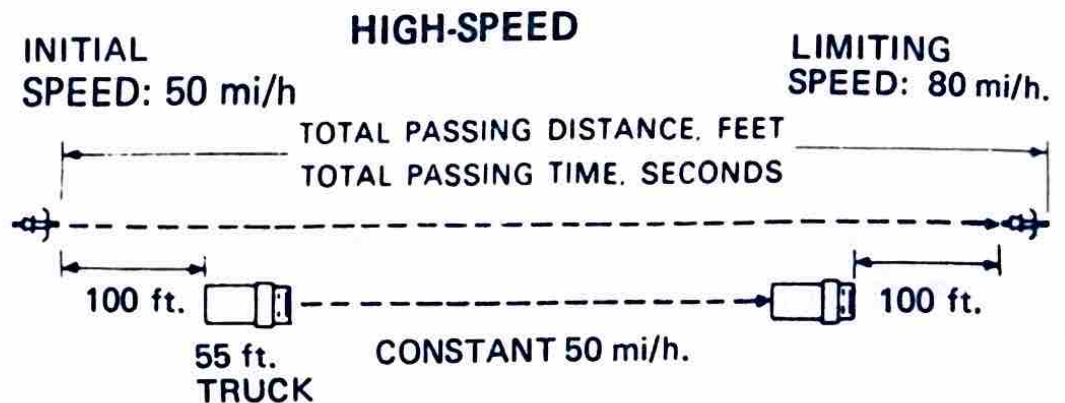
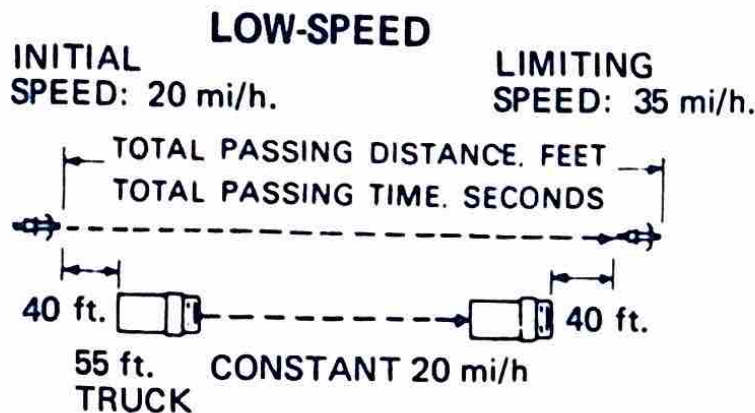

## SPECIFICATIONS

Model		GT80F
Dimensions	Overall length Overall width Overall height Wheel base Minimum road clearance	1,565 mm (61.6 in) 710 mm (28.0 in) 930 mm (36.6 in) 1,045 mm (41.1 in) 170 mm ( 6.7 in)
Weight	Net	64 kg (141.1 lb)
Performance	Minimum turning radius Climbing ability	1,500 mm (59.1 in) 20°
Engine	Type  Cylinder Displacement Bore & Stroke Compression ratio Starting system Ignition system Gasoline tank capacity Oil tank capacity Lubricating system	Air-cooled, 2-stroke, gasoline, Torque Induction Single forward inclined 73 cc (4.45 cu. in) 47 mm × 42 mm (1.850 in × 1.654 in) 9.5 : 1 Primary kick Magneto 4.8 lit (1.3 U.S. gal) 0.7 lit (0.74 U.S. qt) Separate lubrication (Yamaha Autolube)

Model		GT80F
	Spark plug Carburetor Air cleaner	NGK (B7HS) Y16P-3A Oiled, foam rubber
Transmission	Primary reduction system Primary reduction ratio Secondary reduction system Secondary reduction ratio Clutch Gear box type Gear ratio: 1st 2nd 3rd 4th	Gear 68/19 (3.578) Chain 41/14 (2.928) Wet, multi-disc type Constant mesh, 4-speed 39/12 (3.250) 34/17 (2.000) 30/21 (1.428) 27/24 (1.125)
Steering	Caster Trail	26°30' 68 mm (2.7 in)
Tire size (Tire pattern)	Front Rear	2.50 – 15 – 4PR (Universal trials) 2.75 – 14 – 4PR (Universal trials)

Model		GT80F
Suspension system	Front Rear	Telescopic fork, coil spring, oil damper Swing arm, coil spring, oil damper
Frame		Double cradle-type
Electrical	Headlight Tail/ Stoplight Flasher light Pilot lights: Flasher High beam Oil caution Meter light	6V, 30W/30W 6V, 5.3W/25W (3 cp)/25W (32 cp) 6V, 17W  6V, 3W 6V, 3W 6V, 3W 6V, 3W

# GT80F CIRCUIT DIAGRAM

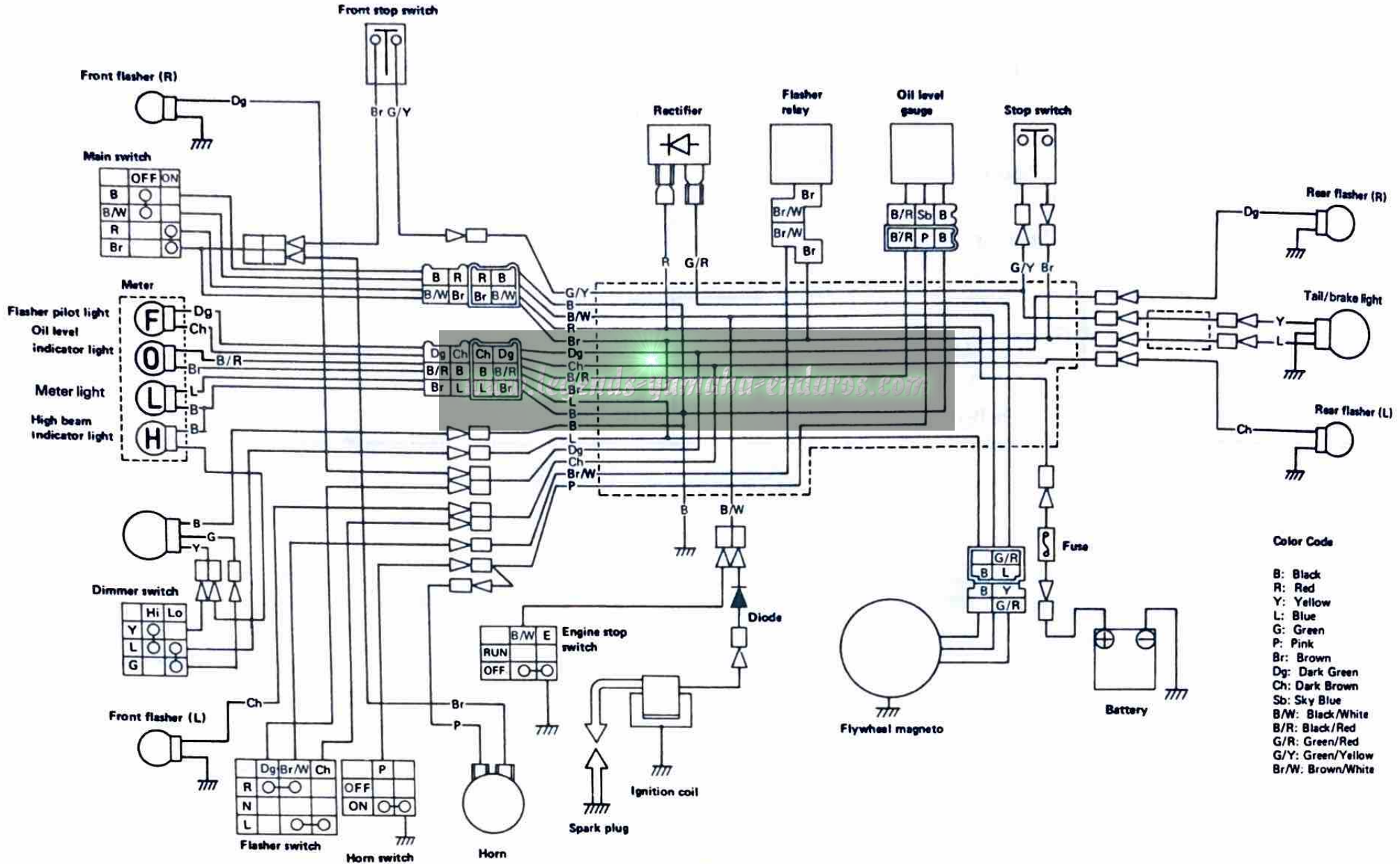

## WARRANTY INFORMATION

Please refer to your copy of the Yamaha Owner's Warranty Guide\* for details of the warranty offered on your new Yamaha.

The Warranty Guide contains the warranty policy, an explanation of the warranty, and other important information. Becoming familiar with these policies will be to your advantage in making the best use of Yamaha's warranty programs.

There are certain requirements which you must meet in order to qualify for warranty coverage. FIRST, your new Yamaha must be operated and maintained properly, as explained in this manual. If you have any questions about any procedure in this manual, please consult your dealer. ABUSE AND NEGLECTED MAINTENANCE MAY LEAD TO MECHANICAL FAILURES WHICH CANNOT BE COVERED UNDER WARRANTY.

SECOND, IF ANY PROBLEMS OCCUR WHICH YOU FEEL SHOULD BE COVERED UNDER WARRANTY, NOTIFY YOUR DEALER IMMEDIATELY. Don't delay, as small problems left unrepaired can become large problems which may not be covered under warranty.

We recommend that the Warranty Guide be used as a folder in which you may keep your registration and other important documents related to your new Yamaha.

\* The Yamaha Owner's Warranty Guide is to be supplied by your Yamaha dealer at the time of purchase. If you did not receive one, or have lost yours, you may obtain extra copies upon request from your Yamaha dealer or by writing to:

**YAMAHA MOTOR CORPORATION, USA**

**P.O. Box 6620**

**Buena Park, California 90622**

**Attn: Warranty Department**

Copies of work orders and/or receipts for parts you purchase and install will be required to document maintenance done in accordance with the emission warranty. The chart below is printed only as a reminder to you that the maintenance work is required. It is not acceptable proof of maintenance work.

MAINTENANCE INTERVAL	DATE OF SERVICE	MILLAGE	SERVICING DEALER NAME AND ADDRESS	SERVICING DEALER SIGNATURE
1,000 km or 600 mi or 1 month				
4,000 km or 2,500 mi or 7 months				
7,000 km or 4,500 mi or 13 months				
10,000 km or 6,200 mi or 19 months				

13,000 km or 8,000 mi or 25 months				
16,000 km or 10,000 mi or 31 months				
19,000 km or 12,000 mi or 37 months				
22,000 km or 13,700 mi or 43 months				
25,000 km or 15,500 mi or 49 months				
28,000 km or 17,400 mi or 55 months				
31,000 km or 19,200 mi or 61 months				

[www.legends-yamaha-enduros.com](http://www.legends-yamaha-enduros.com)

[www.legends-yamaha-enduros.com](http://www.legends-yamaha-enduros.com)

[www.legends-yamaha-enduros.com](http://www.legends-yamaha-enduros.com)