

**YAMAHA**  
**ENDURO**

**125 AT MX**

**OWNER'S MANUAL**

[www.legends-yamaha-enduros.com](http://www.legends-yamaha-enduros.com)

318-28199-11

Congratulations! You are now the owner of a new Yamaha ENDURO 125 ATMX. The ATMX is a high-performance, motorcycle manufactured by the leading manufacturer of motorcycles in Japan.

The ATMX, the newest and top of the Yamaha line model is designed for competition. It features a rugged, powerful, 2-stroke single cylinder, reed valve engine, and Autolube, the revolutionary lubricating system developed by Yamaha Technical Research Laboratory and proven in all Yamaha models.

This manual explains some steps necessary for operating and caring for your new motorcycle. Please read it carefully to become thoroughly familiar with all the features and advantages built into your ATMX.

[www.legends-yamaha-enduros.com](http://www.legends-yamaha-enduros.com)

# 1. Features and Specifications

## 1. Features

### (1) High-performance Single Cylinder Engine

The Yamaha 125 Enduro ATMX utilizes a powerful two-stroke 125 c.c. engine. The new 7-port cylinder, which is another Yamaha technical development, greatly improves engine efficiency and is responsible for high power output throughout a broad RPM range.

### (2) Highly-dependable Yamaha Autolube

Yamaha Autolube provides superior engine lubrication that extends the service life of the engine.

### (3) Easy Starting

The engine can be started by simply disengaging the clutch and kicking the kick pedal without shifting gears back to neutral. This is a valuable convenience to the rider. This is equipped with a magneto. To start this engine, kick the kick pedal.

### (4) Powerful Brakes

Patented waterproof, dustproof brake drums provide safe, fade-free braking on wet or dusty roads.

### (5) Adjustable Rear Cushion

The rear cushions are adjustable to five positions. The rider can adjust spring tension to compensate for varying weights, speeds, and road conditions.

### (6) Front Fork Design

The Yamaha ATMX employs a front fork design well known for its strength and superior handling characteristics. Its use assures the rider of the ultimate suspension for even the roughest terrain.

(7) Tires

The ATMX is fitted with Tires having a block type tread pattern as standard equipment. This particular tread is one of the most versatile available. It gives maximum trail traction

(8) Carburetor built-in starter jet

Yamaha's starter feature is already well-known for providing easy starting. Equipped with this unique carburetor.

[www.legends-yamaha-enduros.com](http://www.legends-yamaha-enduros.com)

### 3. Yamaha Autolube

What is Yamaha Autolube?

Yamaha Autolube is an automatic lubrication system which obsoletes the conventional two-stroke premixing system. Oil stored in the oil tank is metered automatically to the engine, by an oil pump, with the quantity varying according to engine speed and load.

The heart of the system is the compact, precision built oil pump. Driven off the engine crankshaft through reduction gears, the varying oil needs are regulated by the pump which feeds the oil directly to the engine. Regulation is controlled through engine rpm's and throttle setting.

Features:

Yamaha Autolube eliminates the lubrication problems peculiar to two-stroke engines with the conventional "pre-mixing" system. Oil is never contaminated by gasoline prior to delivery to the engine, nor is it subject to de-naturing through storage in the gas tank.

#### 1. The Autolube system result in:

- Oil consumption up to 1/3 less than that of previous lubrication systems.
- Greatly reduced carbon build-up.
- Reduced exhaust emission.

#### 2. The Autolube system provides:

- Fresh oil supply.
- Complete lubrication due to large oil particles.
- No worries about the compatibility of oil and oil-fuel mixing ratios.

#### 3. The Autolube system means:

- Fuel "straight" gasoline only.
- No pre-mixing of oil and gasoline.

## 2. Nomenclature

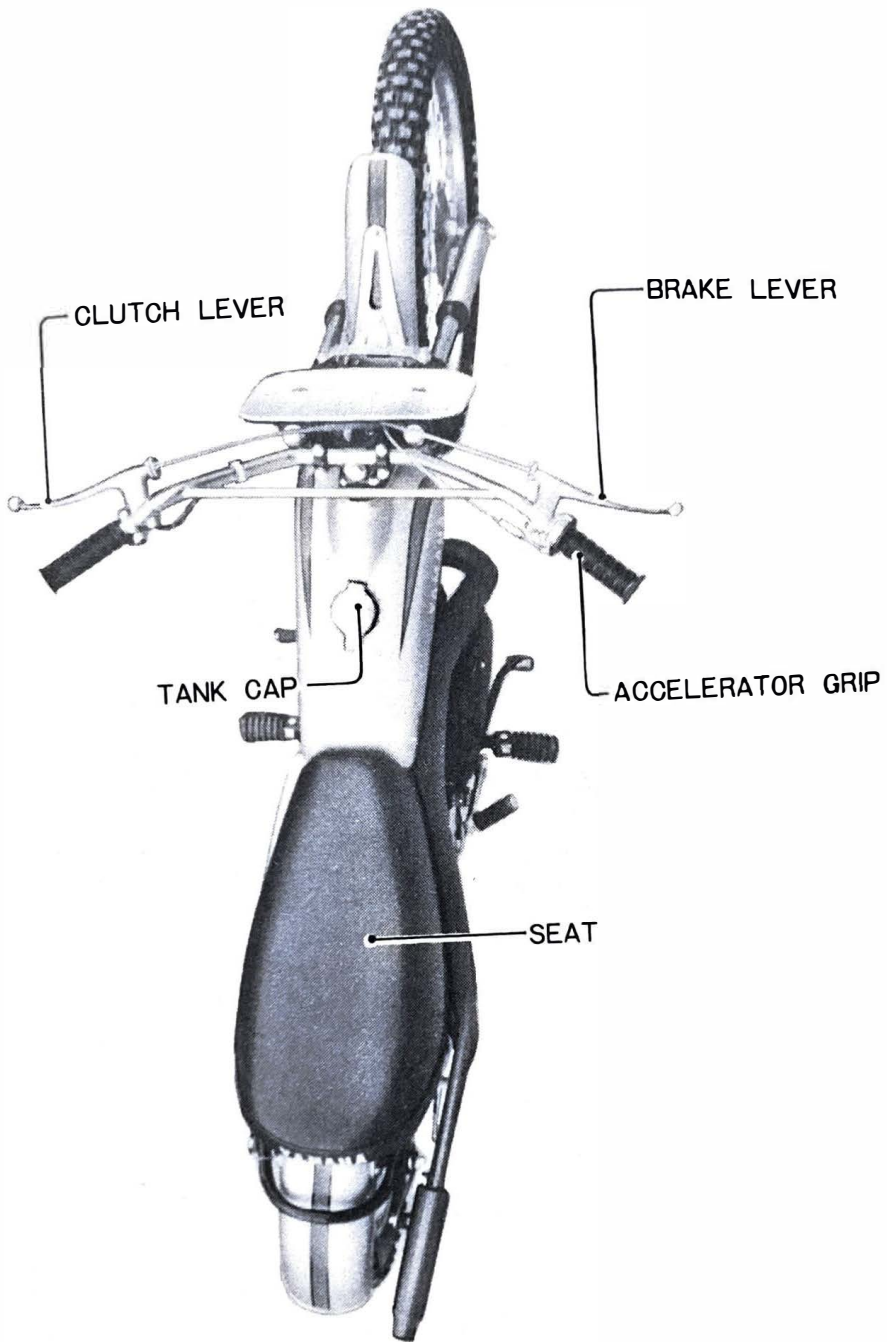

[www.legends-yamaha-enduros.com](http://www.legends-yamaha-enduros.com)

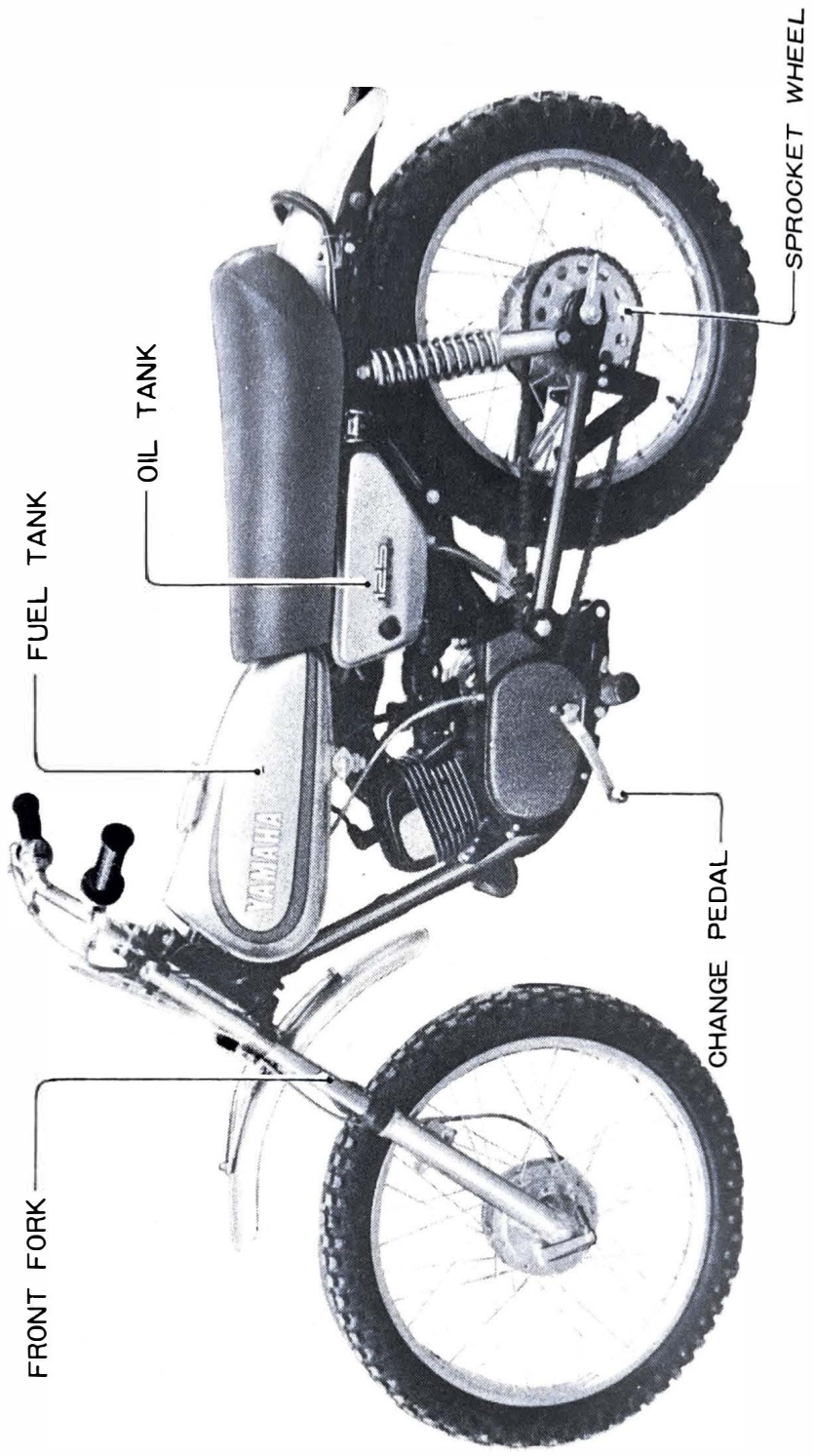

[www.legends-yamaha-enduros.com](http://www.legends-yamaha-enduros.com)

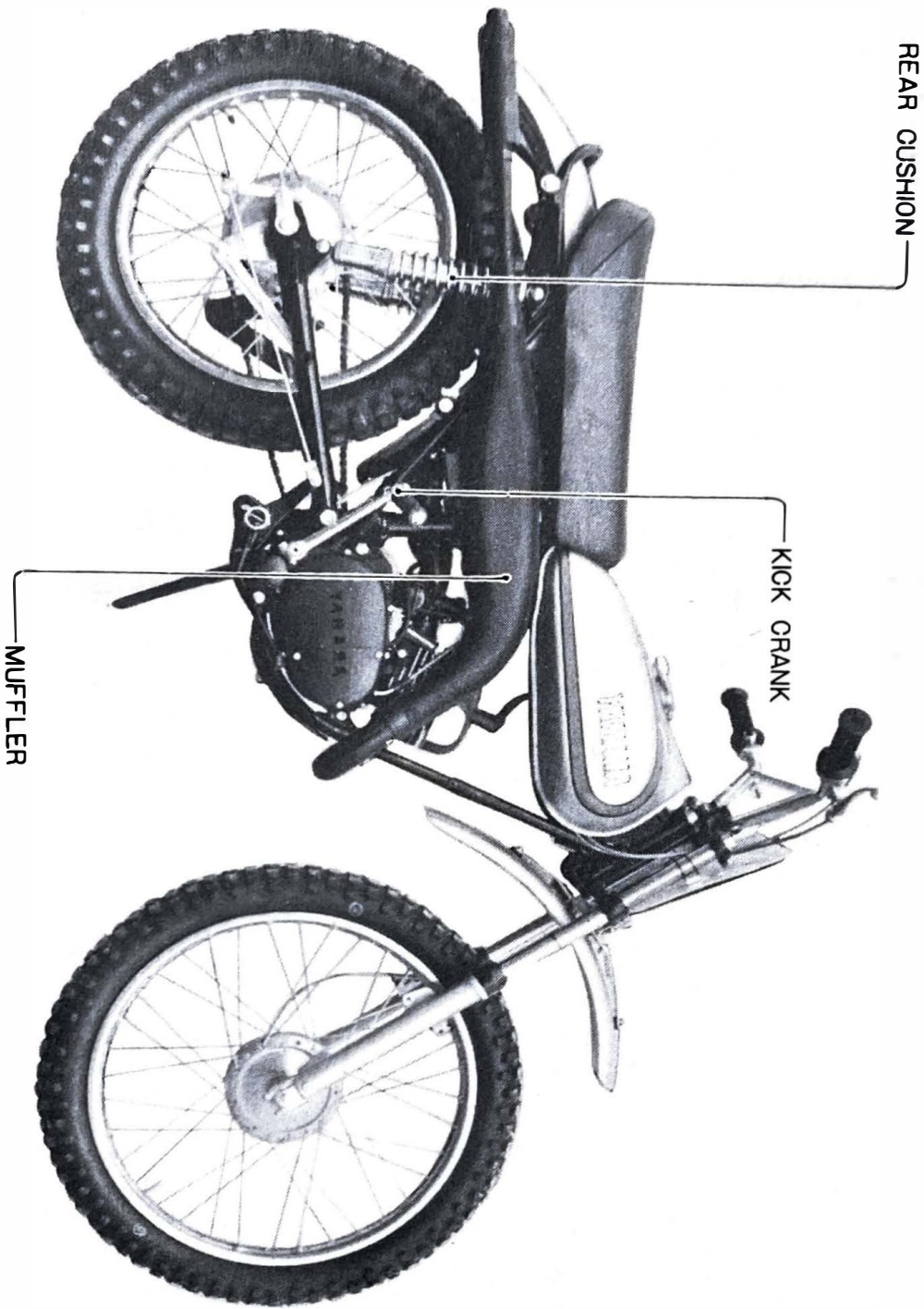

REAR CUSHION

KICK CRANK

MUFFLER

[www.legends-yamaha-enduros.com](http://www.legends-yamaha-enduros.com)



## 4. Basic Instructions

### 1. Gasoline and Oil

#### A. When using Oil Pump.

Yamaha Enduro ATMX equipped with the Yamaha Autolube system, but uses mixing gasoline as fuel.

Gasoline: Use gasoline of high octane rating or more.  
Mixing ratio 30 : 1 (fuel : oil)

Oil: Use Oil for lubrication (SHELL Super M, Castrol R-30 Mineral single grade motor oil #40 or #50)  
Store it in the separate oil tank located under the seat.

#### B. When not using Autolube pump.

The fuel/oil mixing ratio is 15 : 1 when not using the Autolube pump.

It is advisable to use high-octane gasoline (more than 100 octane) and oil (Shell super M. Castrol R-30, Mineral single grade motor oil # 40 or # 50).

#### Note:

After a racing, it is advisable to completely drain the fuel tank and carburetor. It is also advisable to replace the fuel with new one prior to each race.



[www.legends-yamaha-enduros.com](http://www.legends-yamaha-enduros.com)

## 2. Familiarization of Equipment

### (1) Stopping

There are two ways to stop.

- a. Depress the engine stop button.
- b. The ATMX is not provided with a main switch. When stopping the engine engage the clutch and depress the change pedal. Then apply the brake and disengage the clutch.

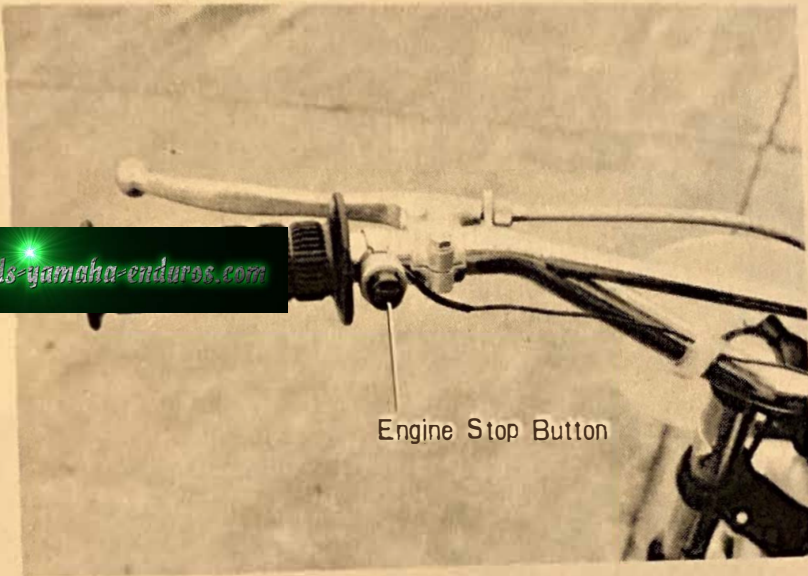

## (2) Fuel Petcock

To allow the fuel to flow into the carburetor, turn the fuel petcock lever to ON. Should you run low of fuel while driving, turn it to RESERVE. The reserve position will enable you to drive approximately 25 miles (40 km). When parking, the lever should be turned to STOP.

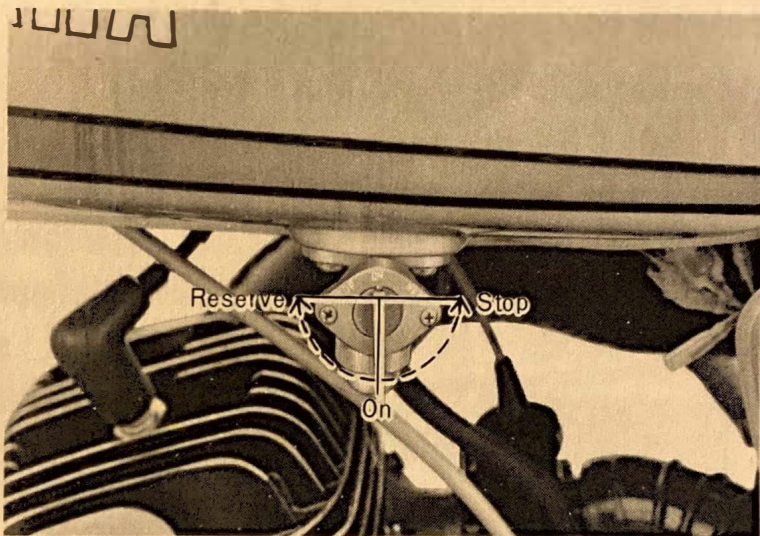

## (3) Rear Cushions

The rear cushions can be adjusted according to load, road conditions, and rider preference.

To adjust the rear cushion insert the screwdriver (service tool) butt-end of the blade into the adjusting hole and then turn it in order to change the position of the toothed notch.

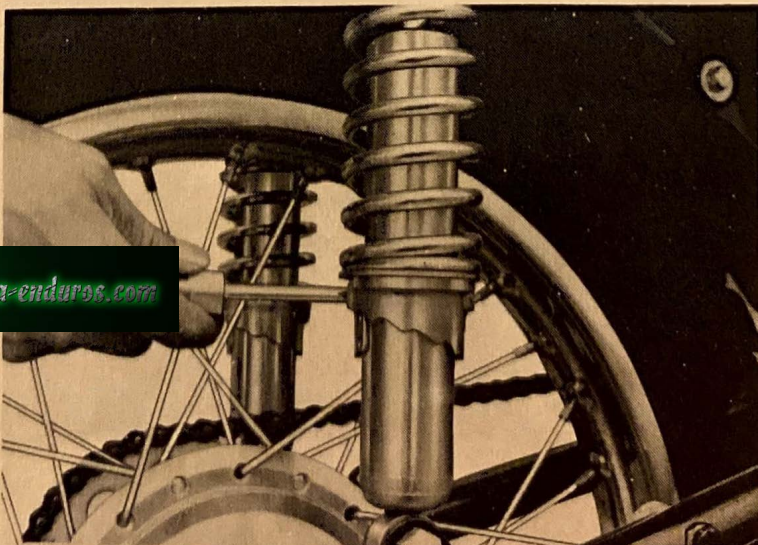

### 3. Pre-operation Check

You should check the following points before each usage.

(1) Is there Sufficient Fuel?

Make sure that there is sufficient fuel for your driving plan.  
Fill the fuel tank with mixing gasoline.

(2) Is there Sufficient Oil? (When using Autolube pump)

If the oil is below the center hole on the glass view port, refill the oil tank with oil (Shell Super M, Castrol R-30, Mineral single grade motor oil #40 or #50)

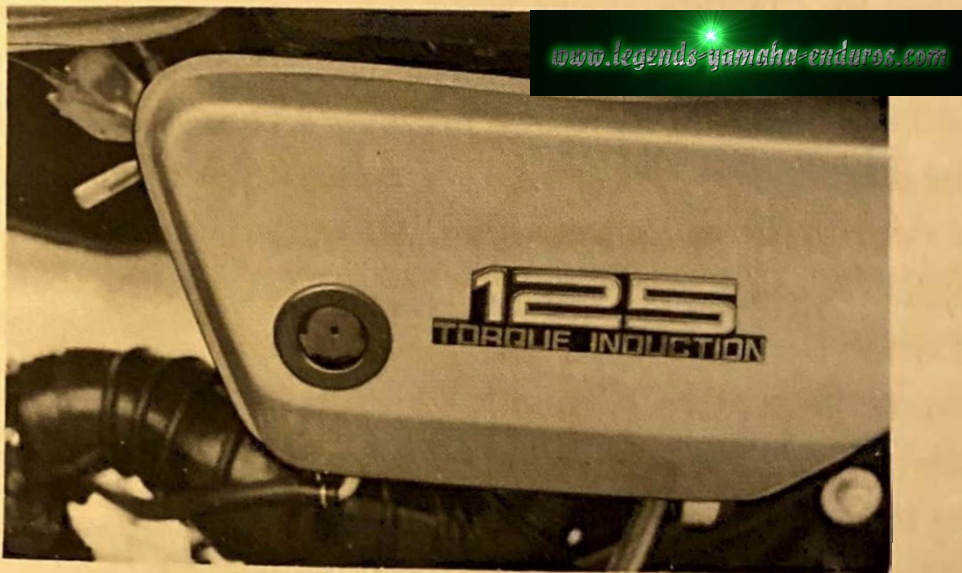

### (3) Do the Front and Rear Brakes Work Effectively?

Try the brake lever (right handlebar) and the foot brake (on the right side of the engine).

## 4. Operation

### (1) Starting the Engine

The carburetor is provided with a starting system to produce the rich air-fuel mixture required for easy starting of the engine. It assures quick starting even in extremely cold weather. The ATMX is provided with a flywheel magneto, and therefore, to start the engine, the kick pedal must be kicked.

#### Preparation for Starting

- Turn the fuel cock lever to the "ON" position.
- The ATMX is equipped with a primary kick starter. The engine can be started by kicking the kick pedal when the transmission is in neutral or by disengaging the clutch first if the transmission is in gear.

#### Starting When the Engine is Cold

Most engines are more difficult to start in cold weather. For easier starting, a richer mixture of gas/air can be obtained by operating the starter lever.

- Depress the starter lever.
- Start the engine by kicking the kick pedal with the accelerator grip closed.

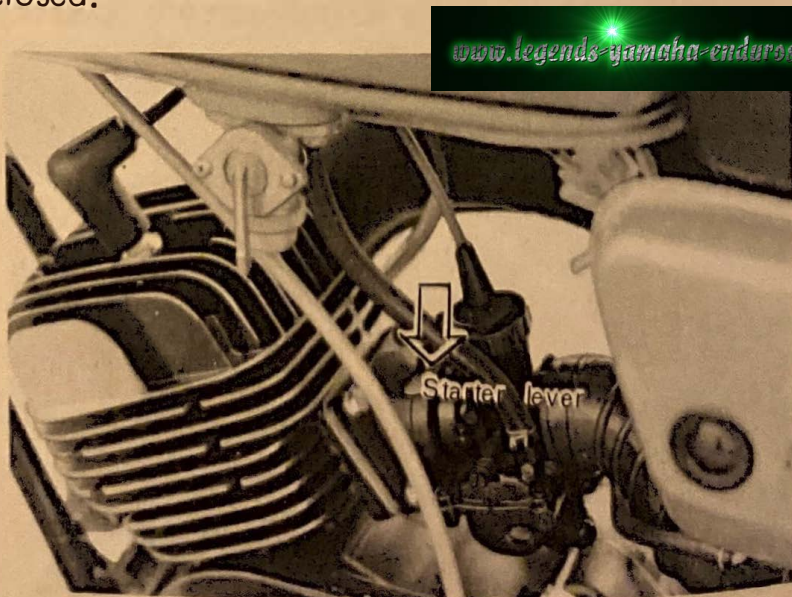

## Starting when the Engine is Warm

When the engine is still warm from running or in warm weather:

- Don't use the starter lever.
- Slightly open the accelerator grip, and kick the kick pedal.

## Warming Up

It is very important to allow a warming-up period of 2 minutes or so after starting the engine.

After the engine has started, the depressed starter lever must be released. Keep the accelerator grip open until the engine begins to run smoothly.

Correct engine warm-up, along with periodic inspections, will assure a longer performance life from your engine.

## (2) Operation Procedure

### Shifting Gears:

The Yamaha ATMX is equipped with a foot-operated, 5-speed transmission.

To shift into NEUTRAL, move the toe section of the change pedal downward into 1st and then raise it slightly to the neutral detent.

The neutral position is between the First and the Second gear position.

FIFTH  
FOURTH  
THIRD  
SECOND  
NEUTRAL  
FIRST

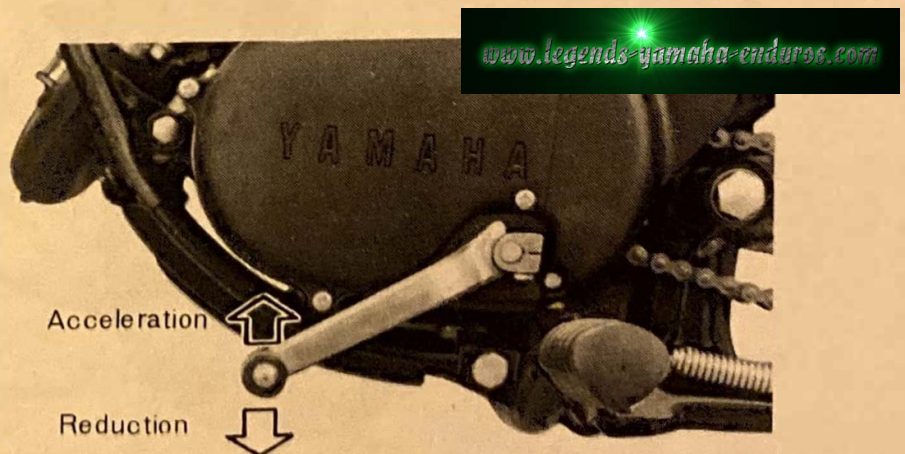

## 5. Inspection and Service

### 1. Inspection and Adjustments

The methods of inspection and adjustment are discussed below. This information will be of value in your daily inspections.

#### Adjusting the Brakes

##### Front Brake:

The correct free play of the front brake lever is 0.2 - 0.3" (5 - 8 mm). To adjust, turn the cable adjusting bolt at the front wheel and/or the adjuster located at the lever. After adjustment, be sure to tighten the lock nut fully.

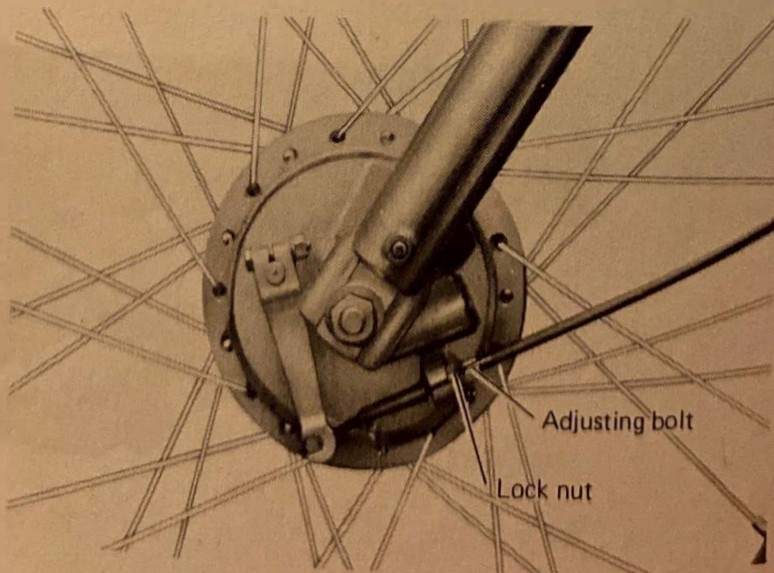
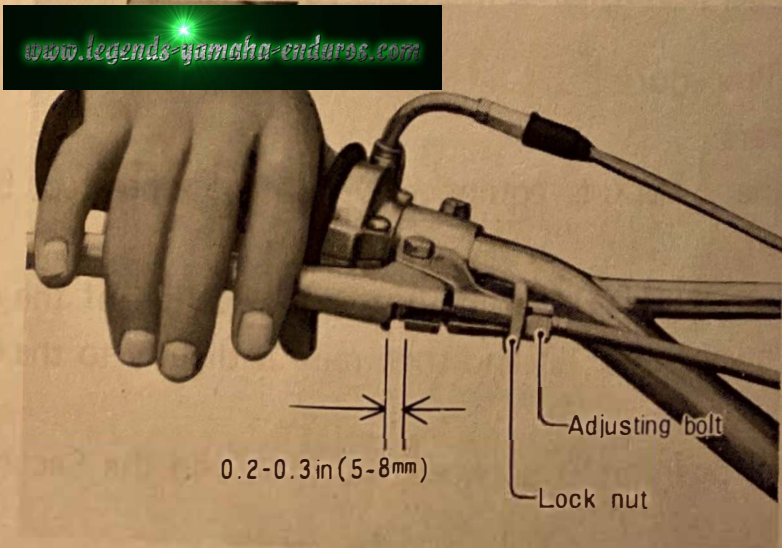

### Rear Brake:

The correct free play of the rear brake pedal is approximately 1" (25 mm). To adjust the play, turn the adjusting nut that is attached to the rear brake cable end, one-half turn at a time.

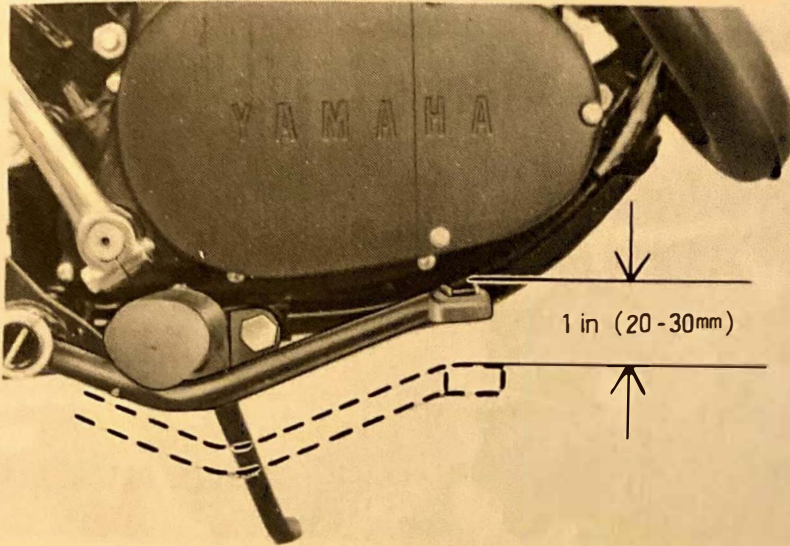

### Note:

This adjustment must be checked any time the chain is adjusted or the rear wheel is removed.



## Checking the Brake Lining:

Disassemble the wheel assembly every 3,000 miles (5,000 km), and check it for wear and clean the brake shoe and brake drum. Take care not to get any oil on the lining friction surface.

## Adjusting the Clutch

The clutch lever should have 0.080~0.120" (2 - 3 mm) free play to maintain full pressure against the clutch facing. If the play is excessive, clutch action will be impaired. If the play is insufficient, the clutch will slip.

### How to Adjust the Clutch.

The ATMX has two clutch adjustment.

1. To adjust the clutch, turn the adjusting bolt attached to the clutch lever holder.

After the adjustment, fully tighten the lock nut(s).

2. Removing the generator cover will expose the adjusting set screw and lock nut. Loosen the lock nut, rotate the set screw in until it lightly seats against a clutch push rod that works with the set screw to operate the clutch.

Back the set screw out  $\frac{1}{4}$  turn and tighten the lock nut. This adjustment must be checked because heat and clutch wear will affect this free play, possibly enough to cause incomplete clutch operation.

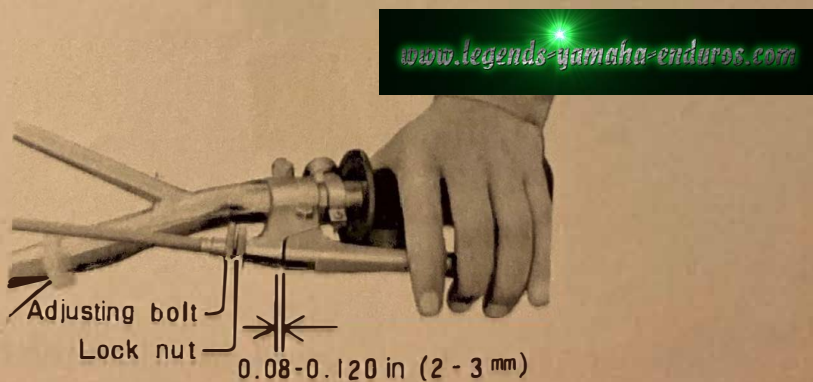

## Replacing the Gear Oil

During the break-in period, replace the gear oil after 30 days from the date of purchase or after 300 miles (500 km) running.

After the first time, replacement should be made every three months or 1,200 miles (2,000 km).

To drain the oil from the bottom of the crankcase, remove the oil drain plug.

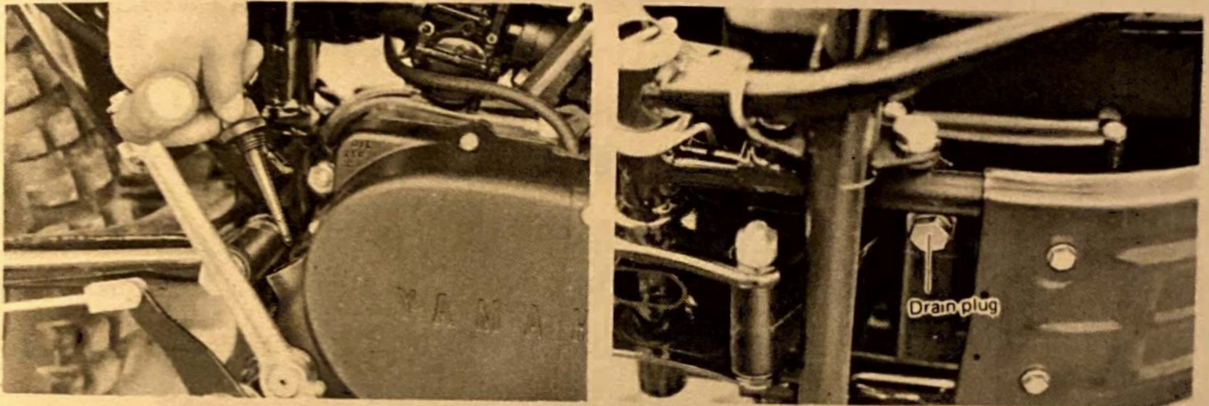

After draining the oil, fully tighten the oil drain bolt, and fill with new oil to the specified level.

Oil Yamaha GEAR OIL, SAE10W/30 MOTOR OIL

Oil Amount 0.8 quarts (0.75 litres)

Keep the oil level  
between these level

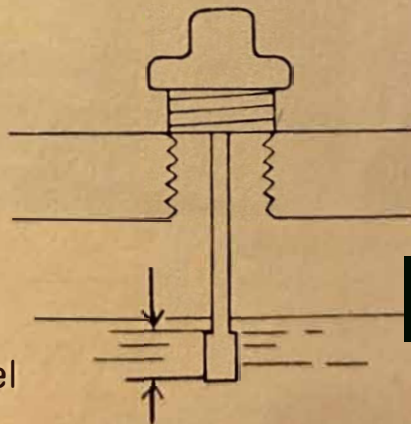

[www.legends-yamaha-enduros.com](http://www.legends-yamaha-enduros.com)

## Air Filter

This model is equipped with a reusable, oil impregnated, foam air filter. It must be removed and cleaned at least once a month, more often if the motorcycle is ridden mainly in the dirt—preferably each time after you spend an entire day in the dirt (8-10 hours operation).

Raise the seat

1. Remove the cleaner mounting bolts.
2. Remove the cleaner case cap.
3. Take out the element.

Wash the foam filter thoroughly in solvent until all dirt has been removed. Squeeze all the solvent out. Pour oil onto the filter (any grade of 20 or 30 wt), work it completely in, and then squeeze out the surplus oil. The filter should be completely impregnated with oil, but not "dripping" with it.

Under no circumstances should you run the motorcycle without the air filter. First, dirt and dust will be able to pass through into the cylinder. Premature engine failure will be the result. Secondly, more air will flow to the engine and there will not be enough gasoline for all the air. The lean mixture will result in higher engine temperatures and possibly severe engine damage.

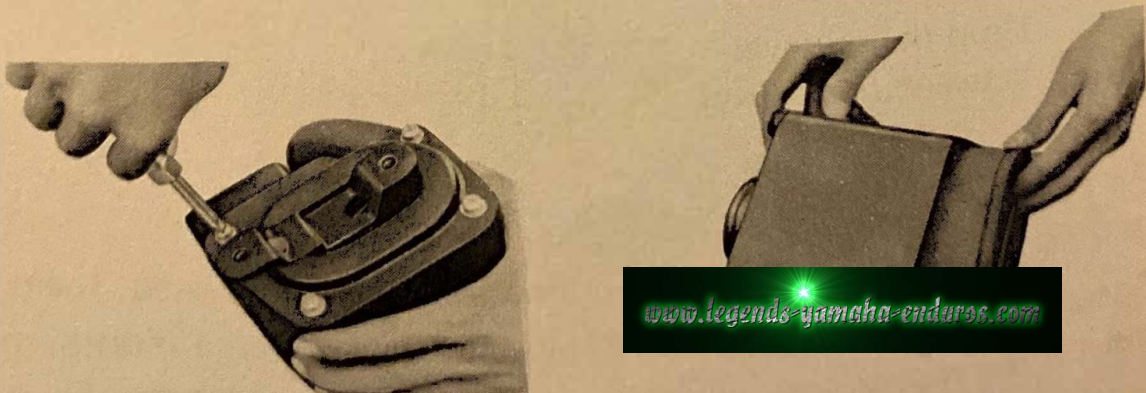
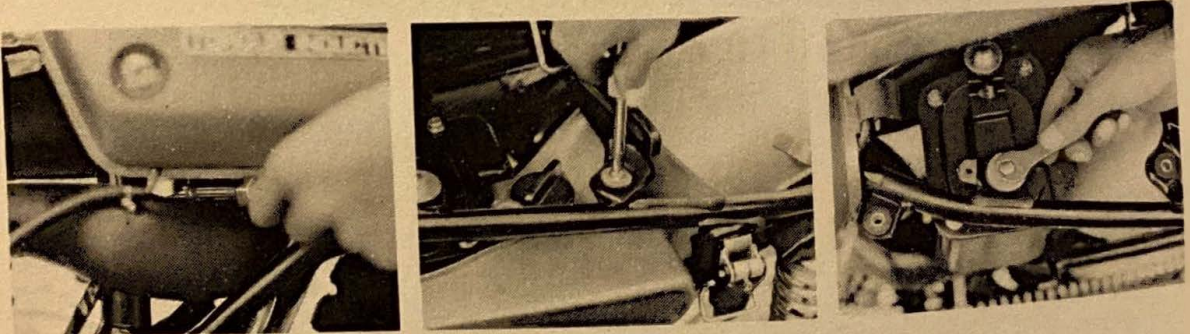

[www.legends-yamaha-enduros.com](http://www.legends-yamaha-enduros.com)

## Checking the Carburetor

Carburetor is set by the factory after careful tests.

Except for the following, do not change the carburetor setting without consulting your local Yamaha dealer.

### a. Pilot Air Screw Adjustment

Tighten the pilot air screw until it lightly seats, and then back it off 1.0

After this adjustment, loosen lock nut (3) to adjust the play of throttle cable (1) to 1/32" (0.5 - 1.0 mm); and turn throttle cable adjuster (2) while pulling throttle cable (1) to check the adjustment. Then lock the throttle cable with lock nut (3).

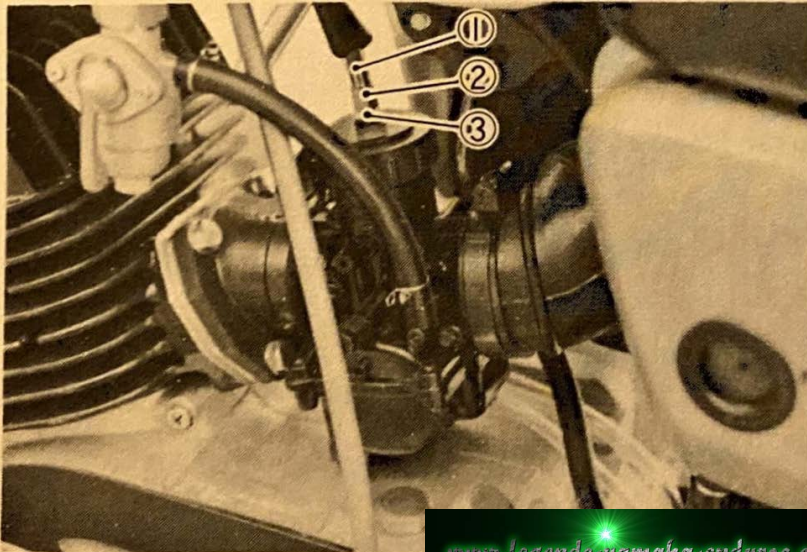

## Carburetor

Type	UM26SC
MJ	190
CA	2.5
JN	4F15-3
AS	1.0

b. Adjusting the Pump Cable (In the case using Oil pump)

After adjusting the carburetor, adjust the pump cable which is coupled with the throttle valve.

- Slightly turn the accelerator grip from the closed position so that free play of the accelerator grip is nil. (In other words, the throttle valve is ready to open with another slight turning of the throttle).
- Turn the pump cable adjusting nut so that the marking on the adjusting pulley is aligned with the guide pin.

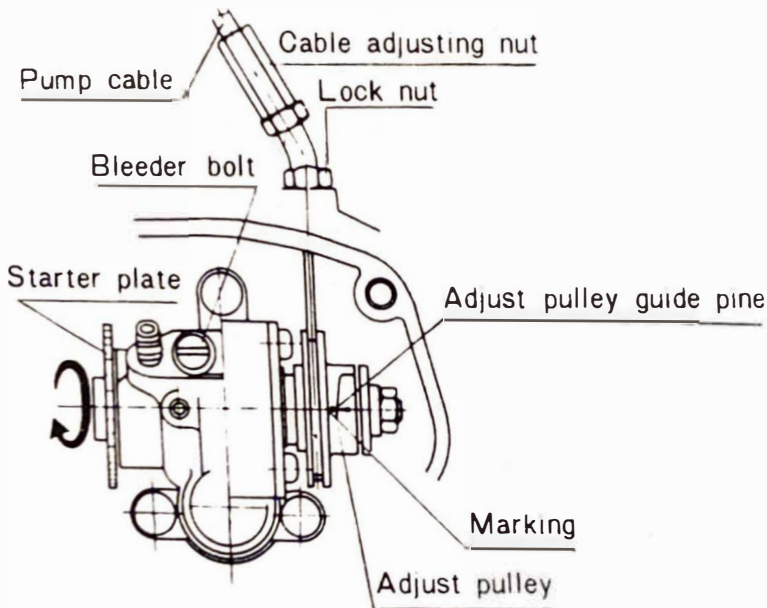

### Adjusting the Drive Chain

The drive chain should have approximately 3/4 -1" (20~25 mm) up and down play at the center of the lower section with the rear wheel on the ground and rider in position. Since a dirty dry chain causes excessive sprocket wear, apply oil at regular intervals. In addition, wash it in gasoline before oiling at every periodic inspection.

## Adjusting Chain Tension:

- a. Loosen the rear brake adjusting screw.
  - b. Loosen the tension bar nut .
  - c. Loosen the rear axle nuts (1). and lock nut (3).
  - d. Loosen or tighten the chain adjusting bolts (4), and shift the wheel shaft so that both ends of the wheel shaft are positioned evenly by utilizing the marks on the swing arms.
  - e. After adjusting, tighten the axle nuts (1).
  - f. Adjust the play of the brake pedal.
- \* After these adjustments, check the play of the brake pedal.

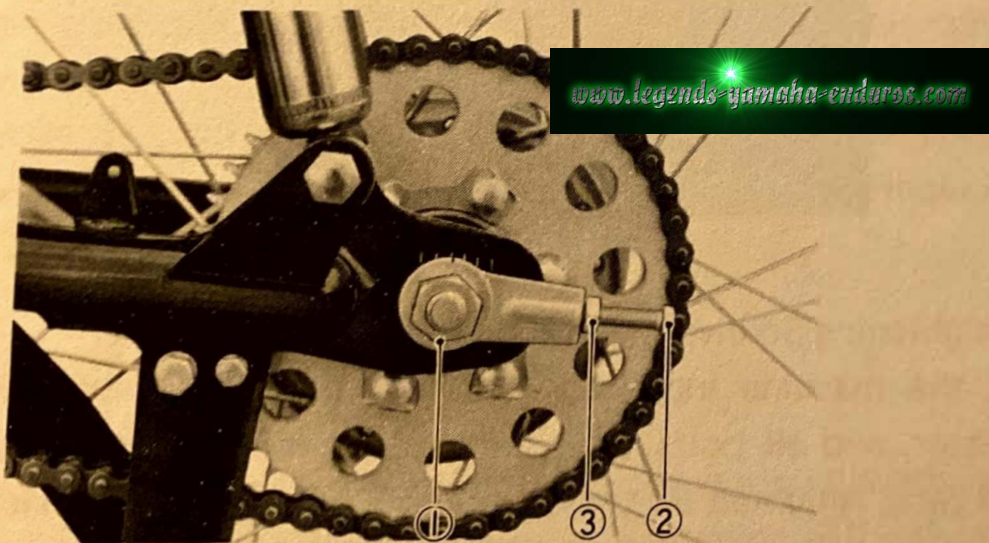

## Cleaning the Combustion chamber and Piston

Carbon accumulation covering the combustion chamber and piston will result in loss of power, engine knock, overheating, and other problems.

- a. Remove the cylinder head and remove carbon from the combustion chamber.
- b. Remove carbon from the piston head.  
To clean them, use a scraper and rags dampened with solvent.
- c. The head bolts must be torqued when the head is reinstalled. Torque the bolts in pattern to a setting of 180 in/lbs.

## Cleaning the Fuel Cock Filter

The fuel cock filter removes impurities from gasoline before they flow into the carburetor. A dirty filter clogs the system, and as a result, the engine will not run properly. Clean it from time to time. Remove the cup from the fuel cock and remove the filter. Wash it carefully in gasoline and reinstall.



[www.legends-yamaha-enduros.com](http://www.legends-yamaha-enduros.com)

## Retightening Screws, Bolts and Nuts

As the machine increases in speed, the road shock will become greater, and all bolts, nuts and screws tend to come loose. Before the race, retighten all these fasteners and make sure that safety wire locks are in place.

## Checking the Spark Plug

A spark plug ignites the air-fuel mixture in the cylinder. A dirty plug causes hard starting, engine misfiring and other problems.

Clean carbon from the electrodes and adjust the point gap.

- Remove carbon build-up, with a wire brush or a wire.
- Adjust the spark plug point gap to 0.020~0.024 in. (0.5~0.6mm).

Hot type	B-8EN
Standard type	B-9EN
Cold type	B-10EN

- Porcelain around the center electrode should be a light tan color.
- Replace the spark plug if the electrodes and porcelain are eroded or cracked. If your machine is frequently ridden at low speeds, the spark plug will become somewhat oily and sooty. Replace it with a hotter type.

## TORQUE:

All fittings require a minimal amount of torque during tightening to keep them from vibrating loose. Excessive tightening will only lead to stripped threads and broken studs. As a rule of thumb, use the following tightening chart:

STUD SIZE	TORQUE
6 mm	90 in/lbs.
7 mm	135 in/lbs.
8 mm	180 in/lbs.
10 mm	300-350 in/lbs.
12 mm	350-400 in/lbs.
14 mm	400-450 in/lbs.
Axle Nuts	500-600 in/lbs.



# WIRING DIAGRAM

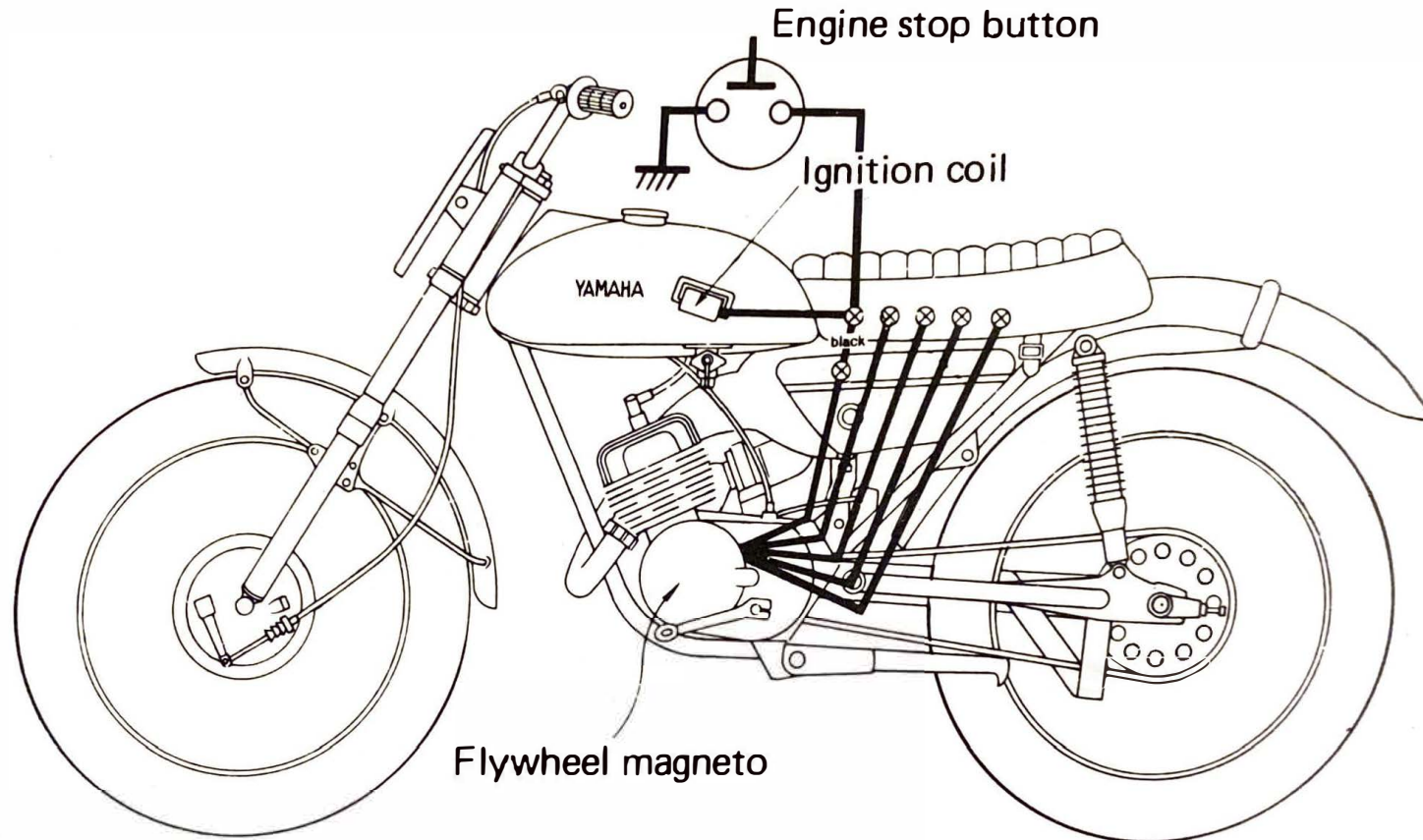



[www.legends-yamaha-enduros.com](http://www.legends-yamaha-enduros.com)



SINCE 1887

**YAMAHA MOTOR CO., LTD.**

HAMAMATSU, JAPAN  
Printed in Japan

