

# YAMAHA MOTORCYCLE

[www.legends-yamaha-enduros.com](http://www.legends-yamaha-enduros.com)

## DT250A/360A ASSEMBLY MANUAL

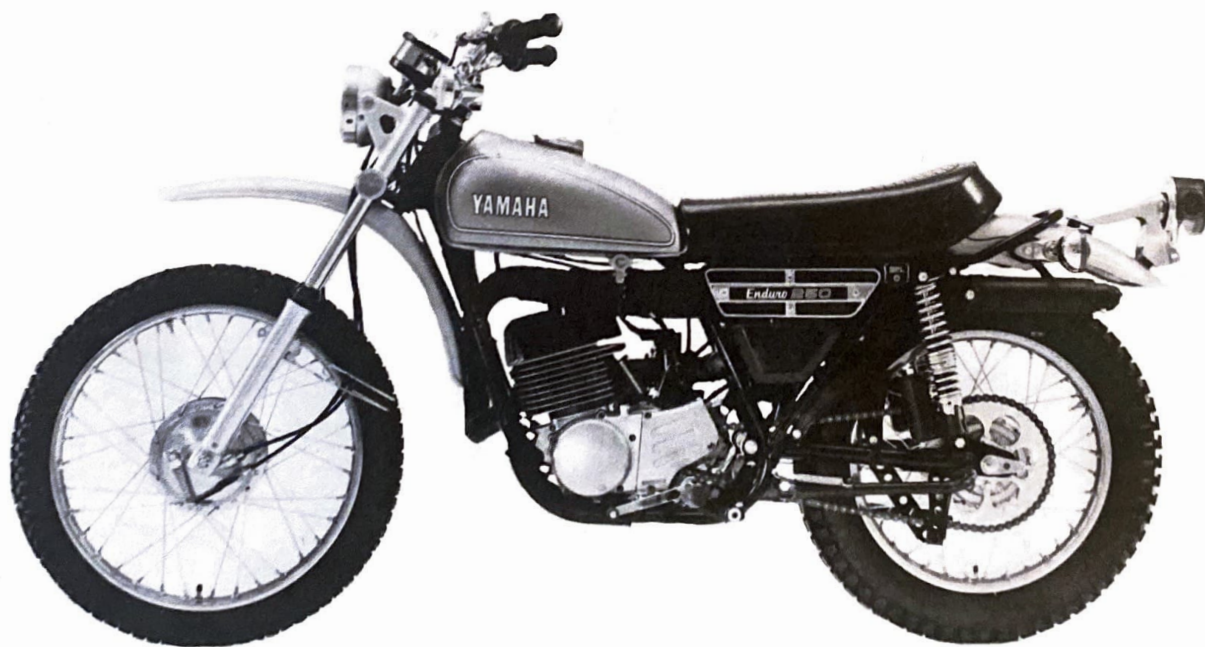

**YAMAHA MOTOR CO., LTD.**

## NOTICE

This manual has been written by Yamaha Motor Company for use by Authorized Yamaha Dealers and their qualified mechanics. In light of this purpose it has been assumed that certain basic mechanical precepts and procedures inherent to our product are already known and understood by the reader.

Without such basic knowledge, incorrect assembly of one of the models listed within these pages could occur. This may render the machine unsafe.

The dealer is further cautioned to review the Service Manual for the machine being assembled in order to acquaint himself with the servicing procedures on the machine after assembly has been completed.

The Research and Service Departments of Yamaha are continually striving to further improve all models manufactured by the company. Modifications are therefore inevitable and changes in specifications or procedures mentioned within this manual will be forwarded to all Authorized Yamaha Dealers and will, where applicable, appear in future editions of this manual.

Should the dealer note a difference between the information in this manual and the actual model, he is advised to contact the U.S. Distributor, Yamaha International Corporation (CANADA Distributor: YAMAHA MOTOR CANADA LTD.), per established routine for clarification.



[www.legends-yamaha-enduros.com](http://www.legends-yamaha-enduros.com)

**YAMAHA DT250A/360A  
ASSEMBLY MANUAL  
1st Edition, July 1973  
SERVICE DEPARTMENT  
YAMAHA MOTOR CO., LTD.  
IWATA, JAPAN  
LIT-11664-38-00**

## TORQUE SPECIFICATIONS

The following torque specifications must be adhered to on every machine. Tightening torque, on multi-secured components, several studs should be in gradual stages and in a pattern that will avoid warpage to the item being secured

Torque settings are for dry, clean threads. Torquing should always be done to the nut, never the bolt head.

### Note:

Certain items with other than standard thread pitches may require differing torque. Consult the model Service Manual or distributor if a question arises.

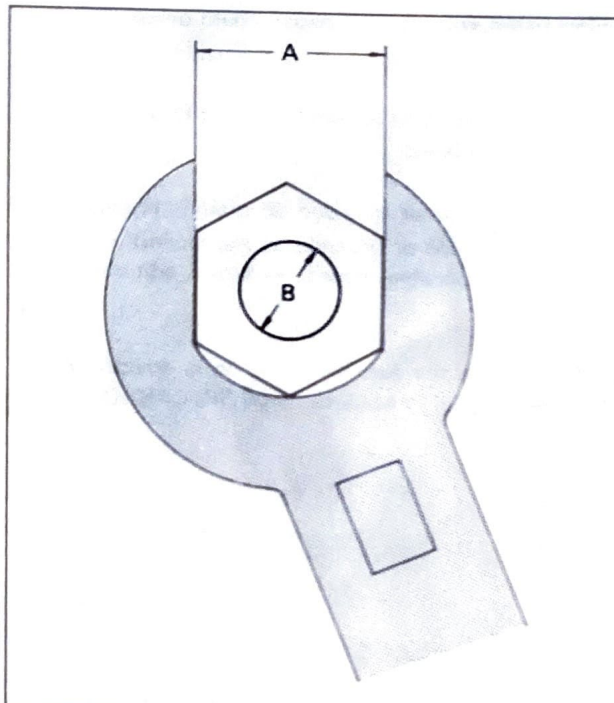

Fig. 1

### Torque specifications

A (Nut)	B (Bolt)	m-kg	lb-ft	lb-in
10mm	6mm	1.0	7.5	90
10mm	7mm	1.5	11	135
13mm	8mm	2.0	15	180
14mm				
17mm	10mm	3.5-4.0	20-29	300-350
19mm	12mm	4.0-4.5	29-33	350-400
22mm	14mm	4.5-5.0	33-37	400-450
26mm	17mm	5.8-7.0	40-50	500-600
27mm	18mm	5.8-7.0	40-50	500-600
30mm	20mm	7.0-8.3	50-60	600-700
SPARK PLUGS		1.5-1.9	11-14	135-170

[www.legends-yamaha-enduros.com](http://www.legends-yamaha-enduros.com)

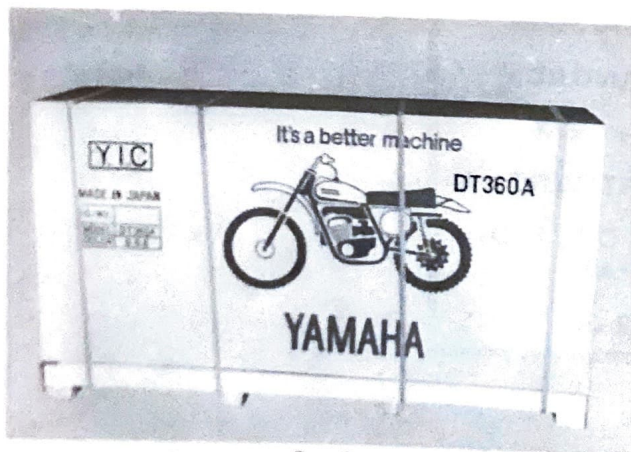

Fig. 2

## UNPACKING

1. The DT250A/360A is put in a cardboard crate. To unpack, cut vinyl bands wound around the cardboard crate using a cutter, and then take it out. (Fig. 2)

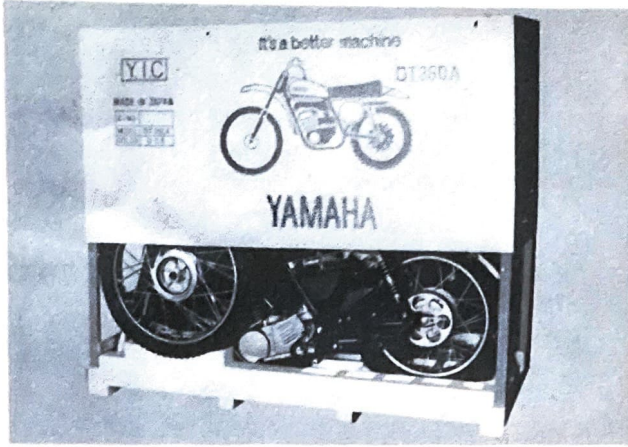

Fig. 3

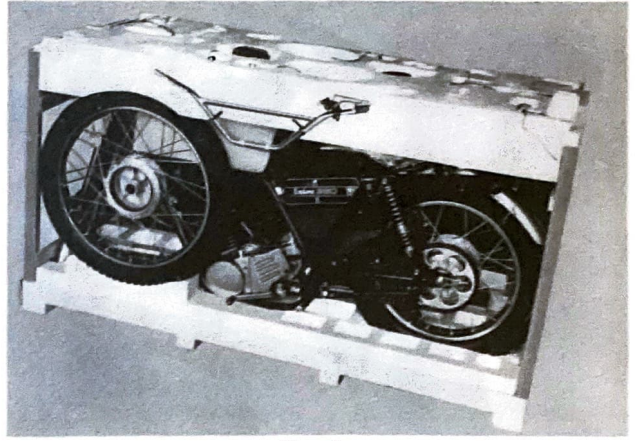
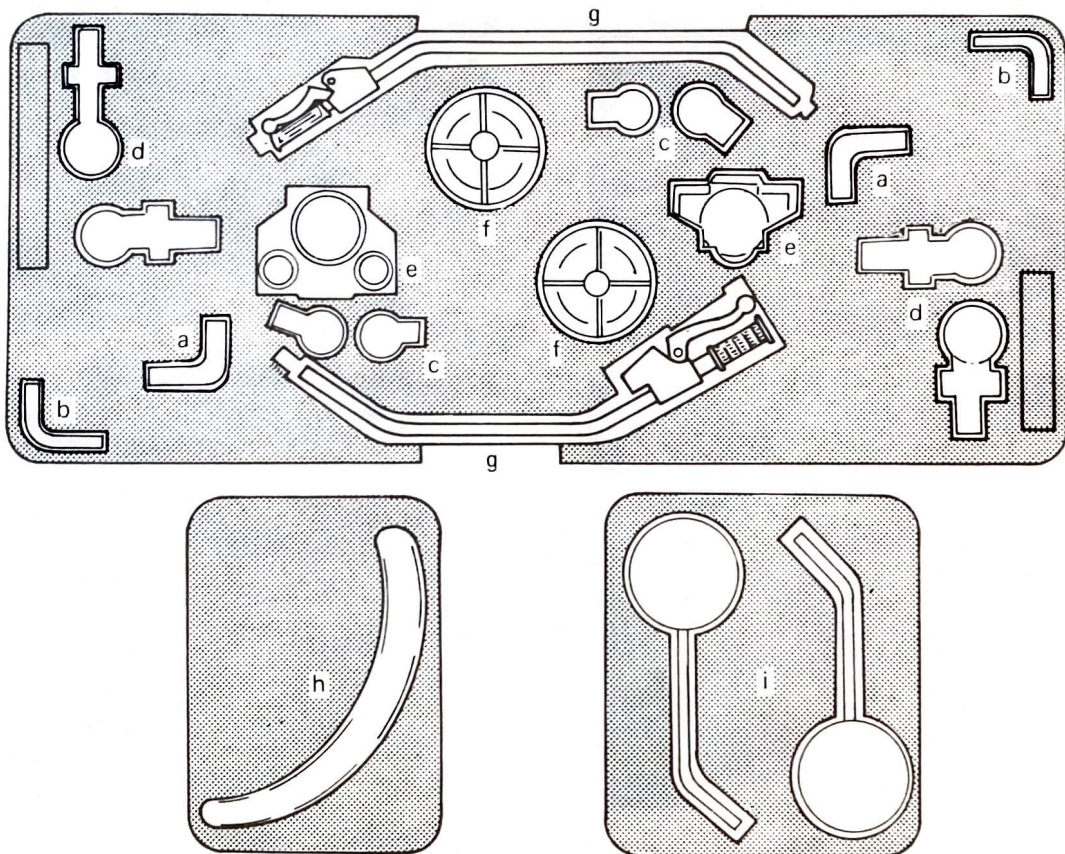

Fig. 4

2. Check the parts contained in the foam styrol case for quantity and damage.  
If any parts are found damaged, replace. Remove the foam styrol case.



Note: Shown above are the parts required for two units of motorcycle.

Fig. 5

Set position	Parts Name	Q'ty
a	Foot rest ass'y (right)	1
b	Foot rest ass'y (left)	1
c	Front flasher light	2
d	Rear flasher light	2
e	Taillight ass'y	1
f	Brake shoe plate ass'y	1
g	Handle bar ass'y	1
h	Front fender	1
i	Rear view mirror	1

(per unit)



(Vinyl bag)

	Parts Name	Q'ty
a	Front fender damper	8
b	Front fender collar	4
c	6 x 20 ~ 25 Hexagon bolt	4
d	6 mm spring washer	4
e	6 mm plain washer	4
f	Owner's service manual	1

(per unit)

## ASSEMBLY INSTRUCTIONS

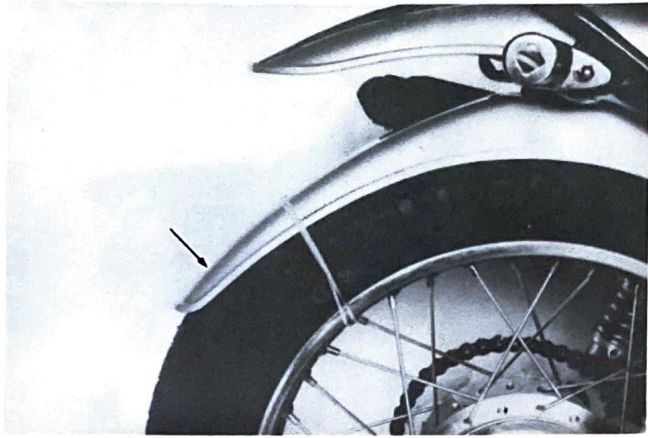

Fig. 6

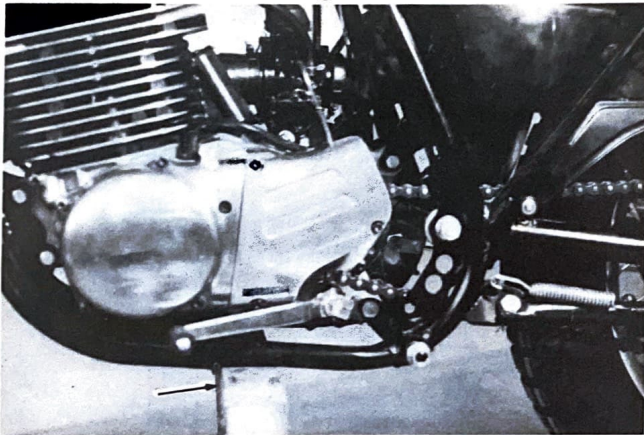

Fig. 7

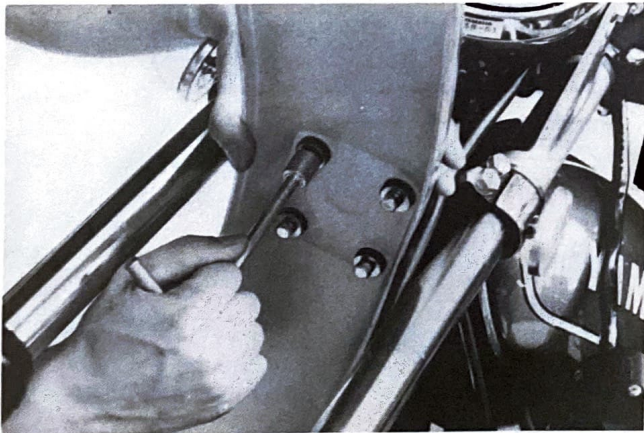

Fig. 8

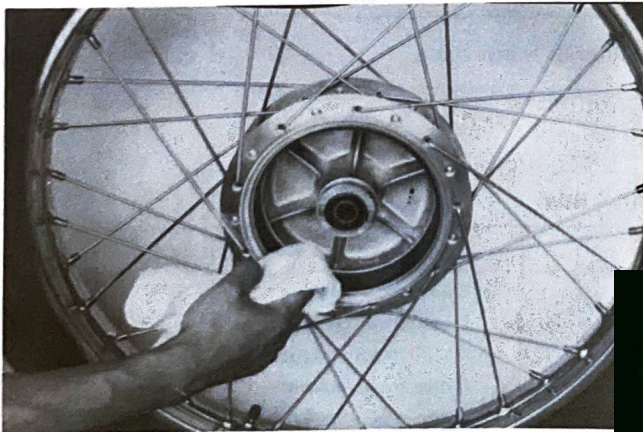

Fig. 9

3. a. Remove the strut from each corner of the crate.  
b. Remove the front fender located between the rear fender and the rear wheel. (Fig. 6)  
c. Remove the front wheel.

4. a. Hold the frame, and lift up the motorcycle. Then take out the rear wheel from the lower foam styrol case.  
b. Place a suitable support under the engine. This will keep the front of the machine elevated while the front fender and front wheel are installed. (Fig. 7)

5. Insert the front fender between the front forks from the under, and secure the front fender using 6-mm bolts, spring washers and plain washers, four each. (Fig. 8)

6. a. Loosen the two nuts securing the axle holder (L-side front fork). Next, remove the wheel shaft nut and plain washer, and pull out the wheel shaft.  
b. Clean the front wheel hub and the brake shoe. (Fig. 9)

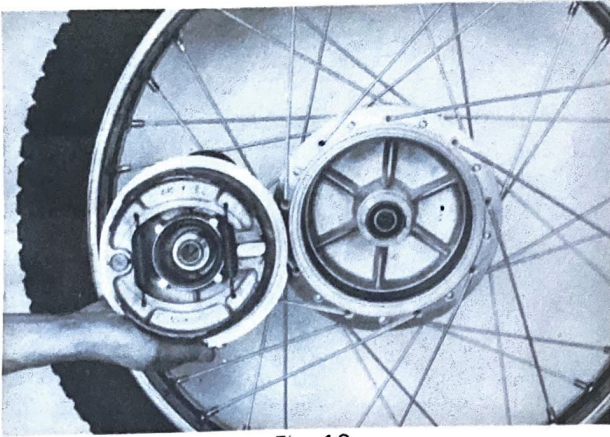

Fig. 10

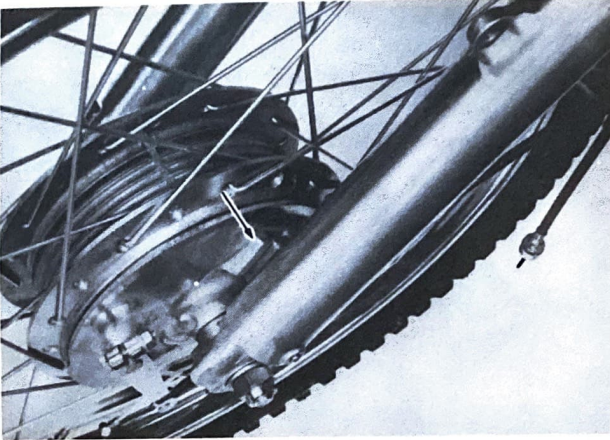

Fig. 11

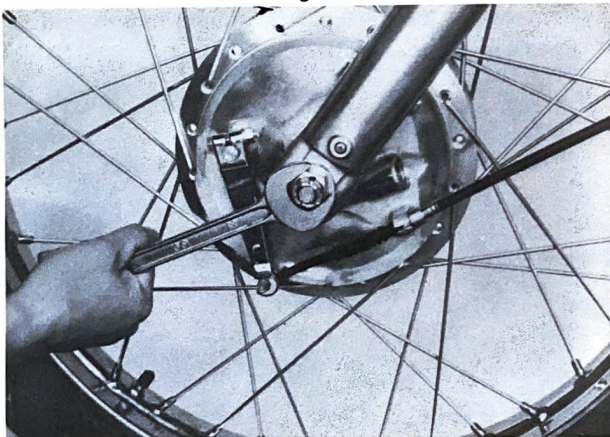

Fig. 12

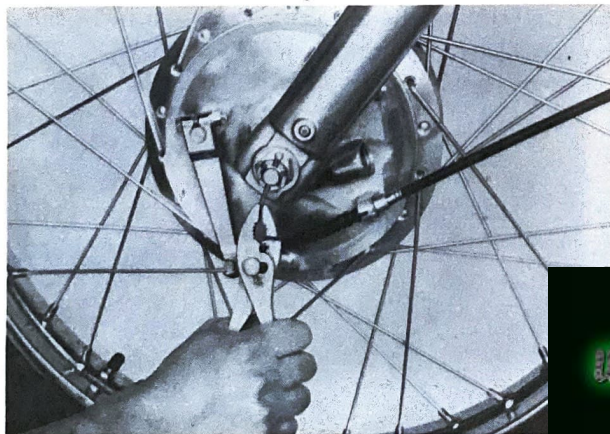

Fig. 13

c. Install the brake shoe in the wheel hub. (Fig. 10)

7. a. Align the stopper (located in the bottom part of the front fork) with the shoe plate groove, and place the front wheel between the front forks. (Fig. 11)
- b. Insert the wheel shaft.

8. Install the plain washer and wheel shaft nut on the wheel shaft, and tighten the nut with specified torque. (Fig. 12)  
Tightening torque: 7.0-10.0 m·kg (53.5-75.0 lb·ft)

9. Lock the wheel shaft nut with the cotter pin (contained in vinyl bag).

**Note:**

The cotter pin should be installed with the open ends pointing down, prior to bending the ends apart. (Fig. 13)

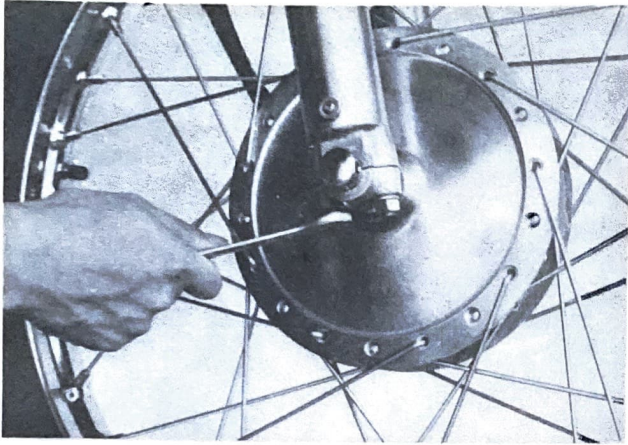

Fig. 14

10. Tighten the two axle holder nuts with specified torque. (Fig. 14)

Tightening torque: 0.8-1.3 m·kg (70-110 lb·in)

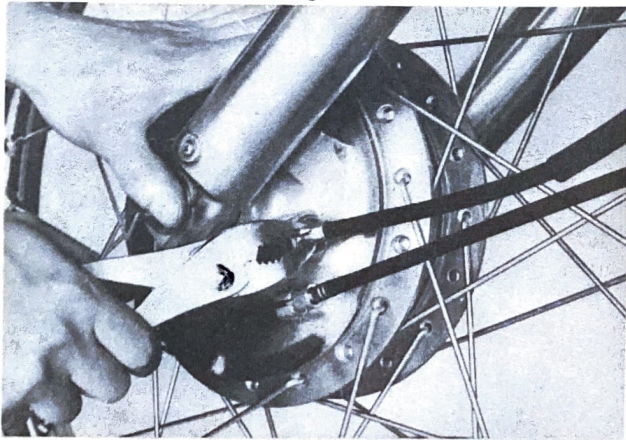

Fig. 15

11. a. Insert the speedometer cable into the gear unit in the front wheel hub.

- b. After setting the meter cable end correctly in the gear unit, fit the circlip (attached to the cable) in the groove around the wheel hub. (Fig. 15)

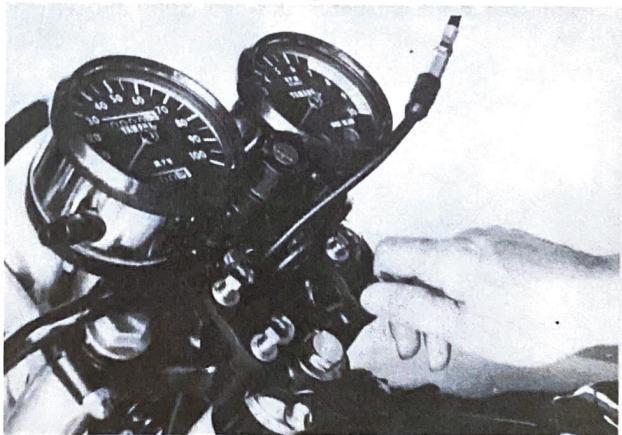

Fig. 16

12. Remove the four hexagon bolts, and remove the two handle upper holders. (Fig. 16)

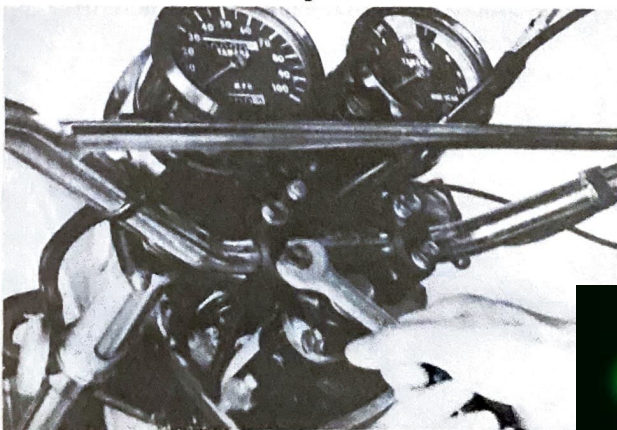

Fig. 17

13. Install the handle bar ass'y using the two handle upper holders and bolts (removed in # 13). (Fig. 17)

Tightening torque: 1.8-2.5 m·kg (160-230 lb·in)

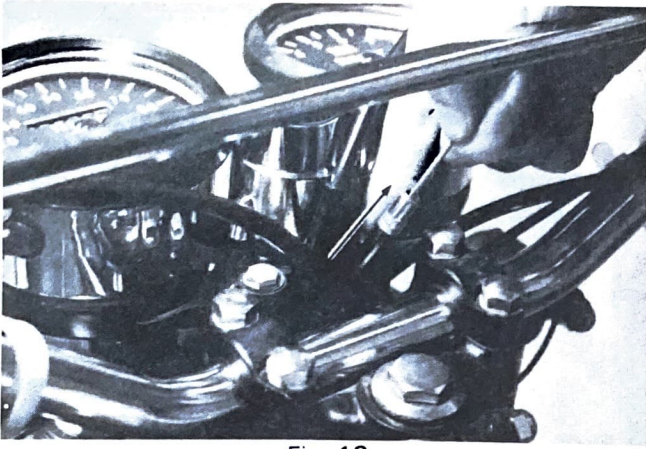

Fig. 18

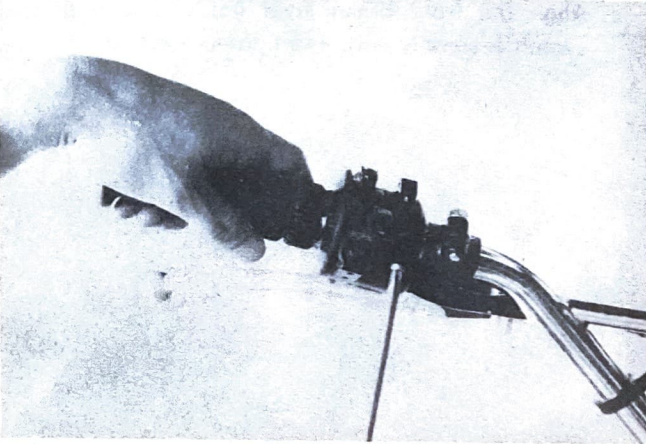

Fig. 19

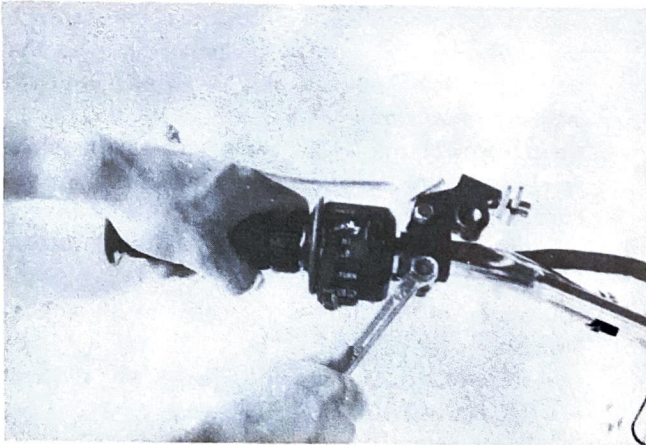

Fig. 20

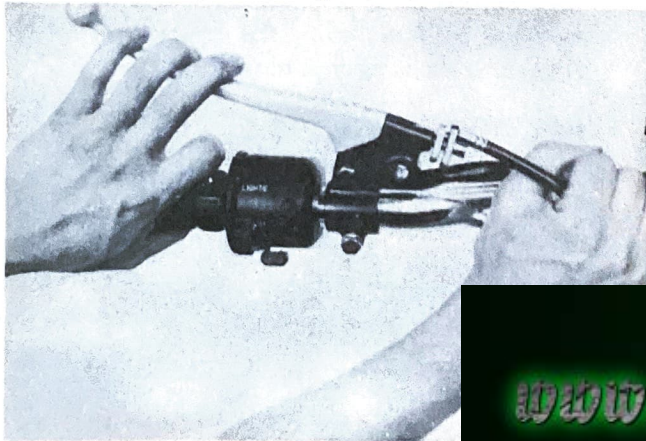

Fig. 21

14. Thread the front brake wire through the wire holder attached to the front fender and then pull upward the wire through the hole in the rear of the meter on the handle crown. (Fig. 18)

15. a. Loosen the left handle switch assembly holding screw, and install the switch assembly on the handle grip end.  
b. Install the clutch lever holder on the left of the handlebar, then secure the handle switch assembly to the handlebar using the holding screws. (Fig. 19)

- c. Secure the clutch lever holder to the handlebar using the holder holding bolt.

- d. Connect the clutch cable to the clutch lever, and adjust the play of the clutch cable.



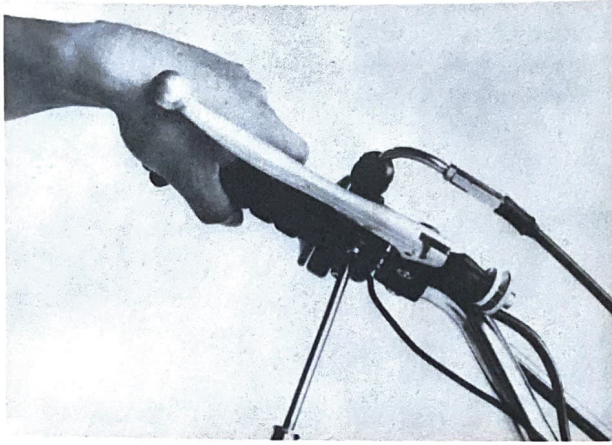

Fig. 22

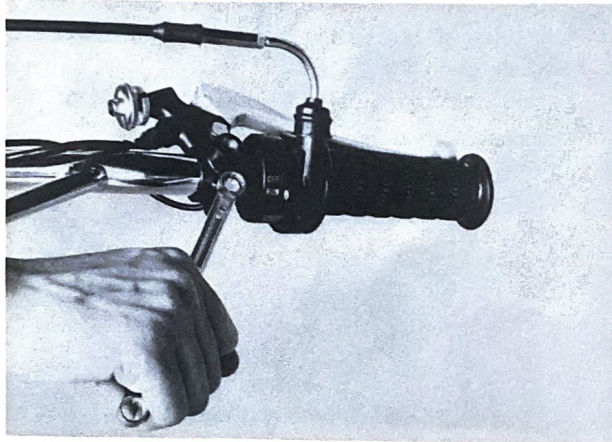

Fig. 23

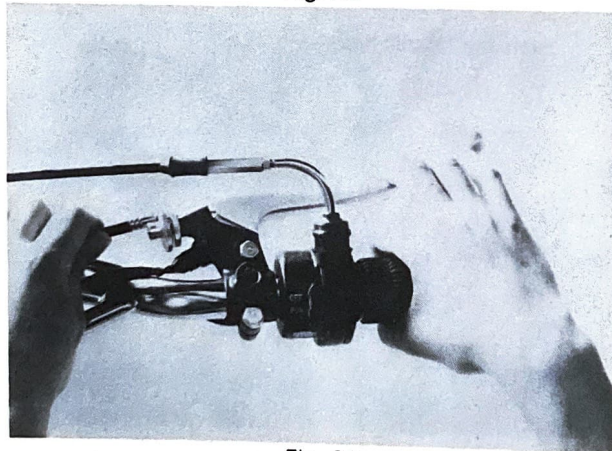

Fig. 24

16. a. Insert the front brake lever holder into the right of the handlebar.
- b. Loosen the two holding screws on the right handle switch assembly, and install the handle switch and grip on the right of the handlebar. Slip the grip over the handlebar end, and tighten the handle switch holder holding screws.

- c. Align the front brake lever holder end with the switch assembly end, and tighten the bolt.

- d. Fully loosen the brake lever lock nut, and screw in the adjusting bolt until it becomes tight so that the clutch leverlock nut slot is aligned with the adjusting bolt slot.

Next, connect the brake cable end to the brake lever, and hook up the outer brake cable to the lock nut. Then, fully pull in the brake lever, and release it abruptly. At the same time, pull the outer brake cable quickly. This makes easy the connection of the outer brake cable to the adjusting bolt.

For detailed cable routing, refer to "CABLE ROUTING DIAGRAMS"

- e. Back out the cable length adjuster until the brake lever has 5 - 8 mm (0.2 - 0.3 in) slack. Tighten the adjuster lock nut.

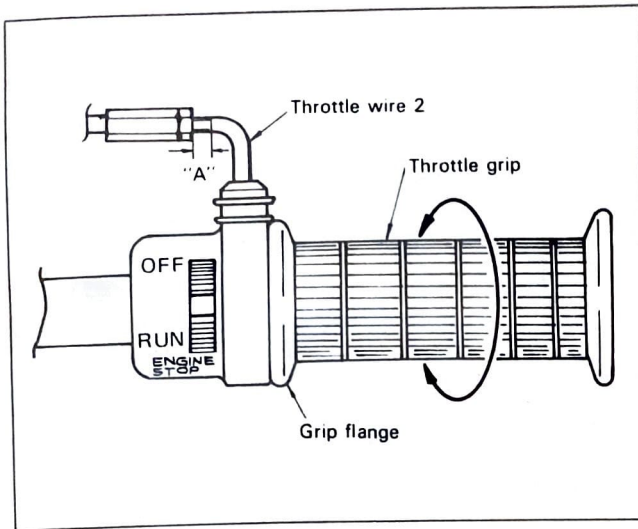

Fig. 25

## IMPORTANT

The play in turning direction of the throttle grip must be adjusted to prevent the throttle wire from slipping off the throttle wire holder.

### Throttle wire adjustment

1. Check play in turning direction of throttle grip.  
The play must be in the range of 5 to 10mm at grip flange. (Measuring point is optional.)
2. If the play exceeds 10mm, adjust with adjusting nut on throttle wire 2 side.
3. If adjustment is impossible with the adjusting nut (because distance "A" must be maintained more than 4mm), then use adjusting nut on throttle wire 1 side.

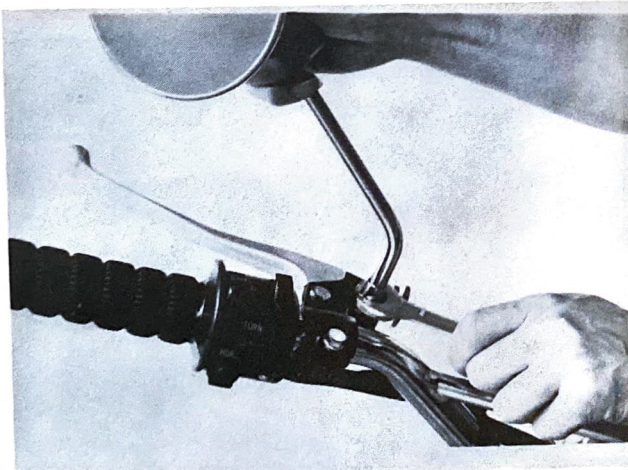

Fig. 26

17. a. Install the mirror ass'y on the left side of the handlebar.  
b. Adjust for proper rear view.

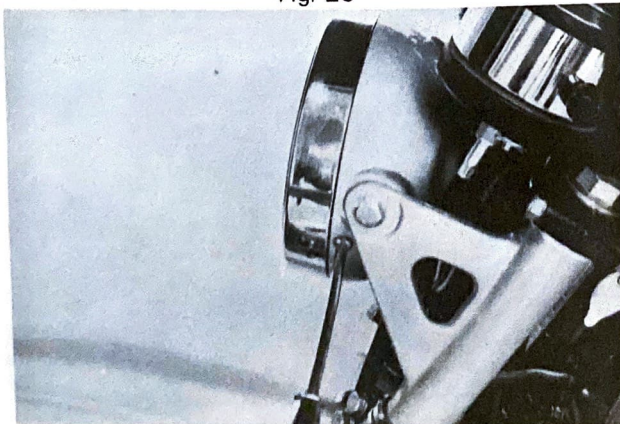

Fig. 27

18. Remove the pan-head anchor screw from the lower of the headlamp body. Insert a slotted-head screwdriver between the body and the lens ass'y mounting ring on the bottom of the headlamp body, and pry out the lens ass'y.

**Note:**

Care should be taken not to scratch the head lamp body with the slotted-head screwdriver. Also be careful not to lose any screw.

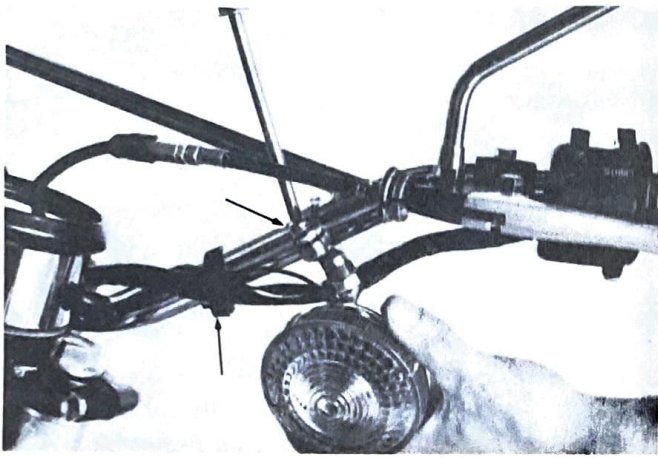

Fig. 28

19. a. Install the front flasher lamps to the bottom part of each tension bar attached to the handlebar. (Fig. 28)
- b. Next, secure the lead wires to the handlebar using bands, and insert the lead wire ends into the head lamp body.

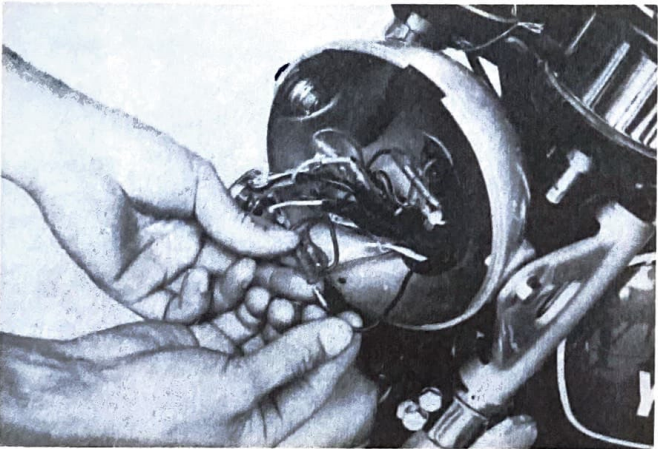

Fig. 29

20. Connect lead wires inside the head lamp body. Lead wires of the same color should be connected. (Fig. 29)

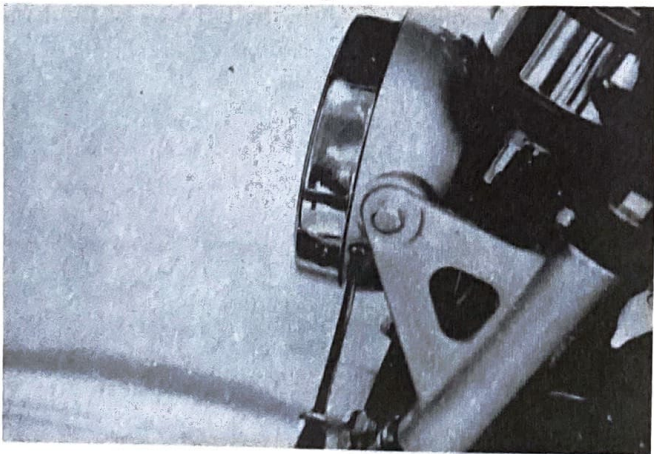

Fig. 30

21. Firmly fit the lens ass'y in place. Make sure no wires are pinched. Then, secure the lens ass'y with pan-head anchor screw. (Fig. 30)

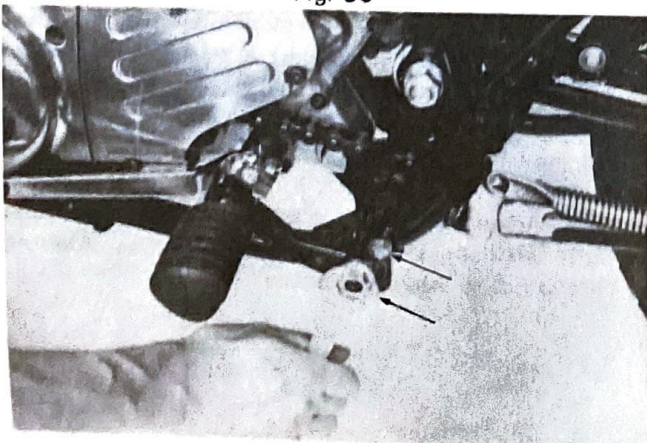

Fig. 31

22. Install the foot rests, both right and left. To install, secure them with special nuts, and then tighten the lock bolts. (Fig. 31)  
Tightening torque:  
5.0 - 7.0 m·kg (37.5 - 52.5 lb·ft)

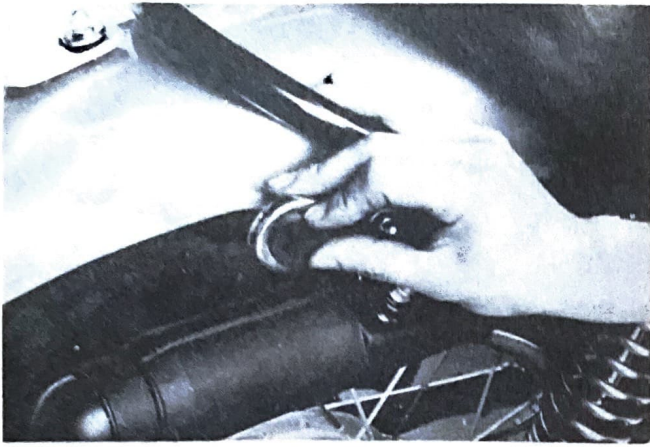

Fig. 32

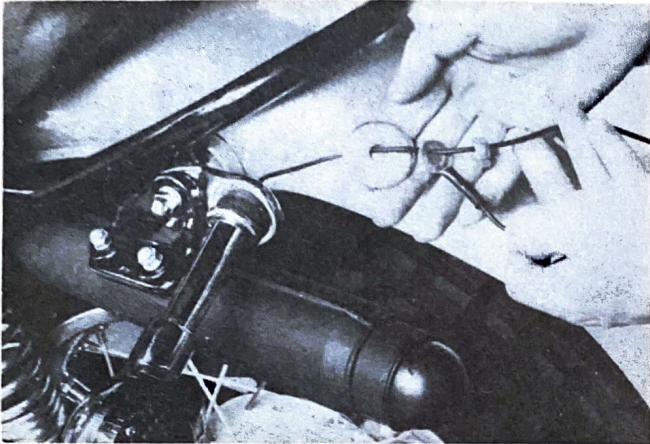

Fig. 33

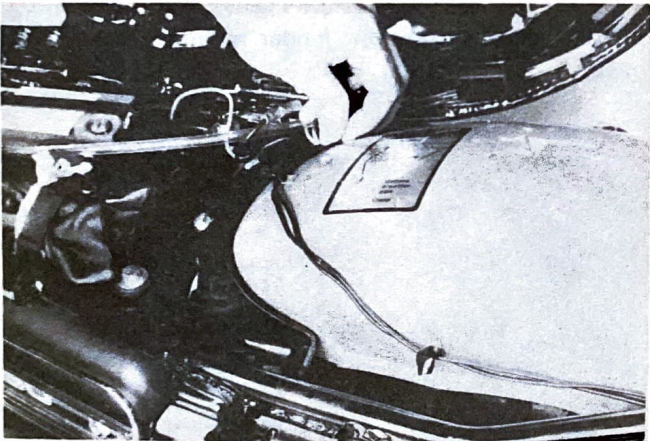

Fig. 34

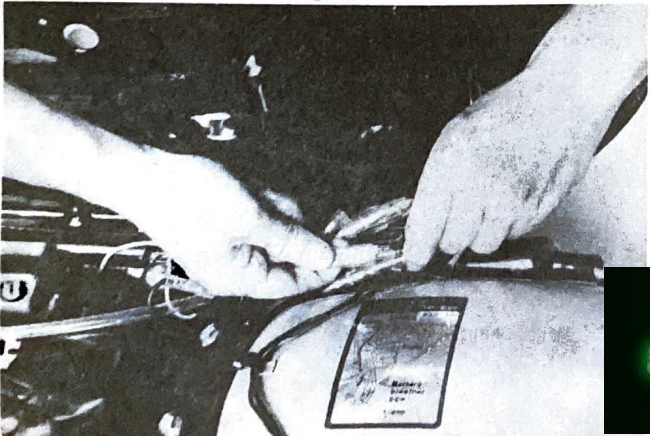

Fig. 35

23. a. Install the flasher lamp damper rubber on the rear flasher lamp stay. (Fig. 32)
- b. A chocolate colored tube is attached to one of the lead wires on the left side. Install the flasher lamp, and install the another flasher lamp (attached a dark green tube) on the right side.

- c. When installing the flasher lamp, secure the negative lead wire between the special washer and the nut. (Fig. 33)

24. a. After installing the flasher lamp, clamp the lead wire to the top of the rear fender. (Fig. 34)

- b. Connect the flasher lamp lead wires to the lead wires of the same colors in the wire connector cover on the right top of the rear fender. (Fig. 35)

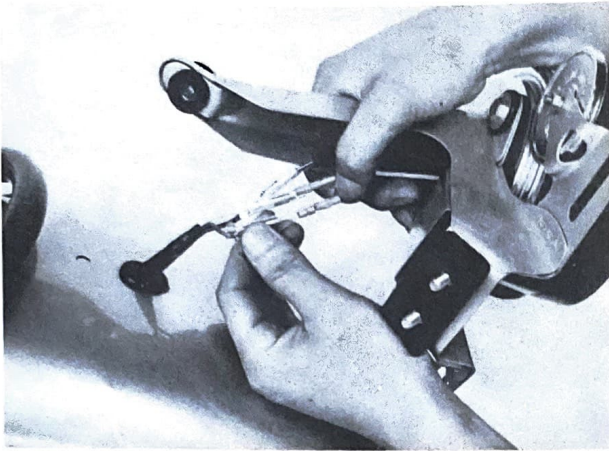

Fig. 36

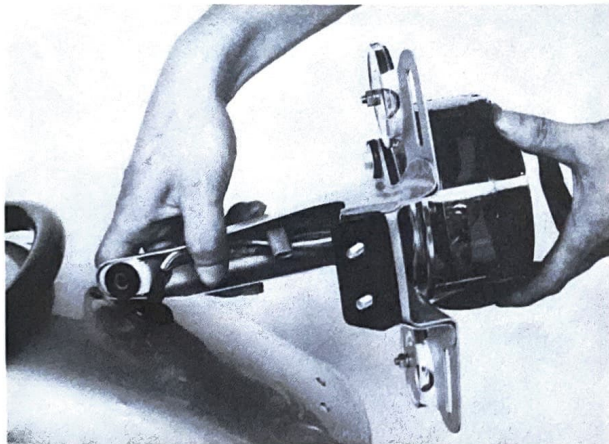

Fig. 37

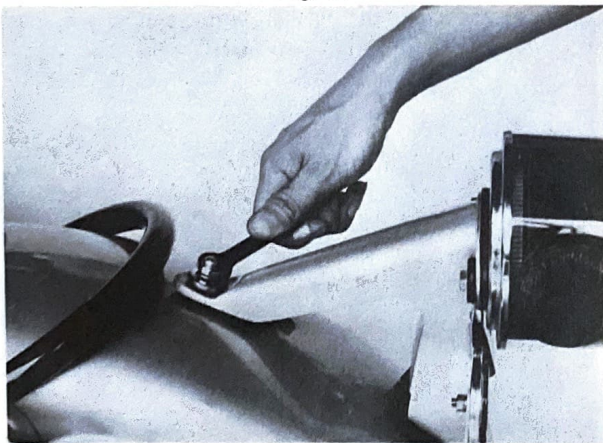

Fig. 38

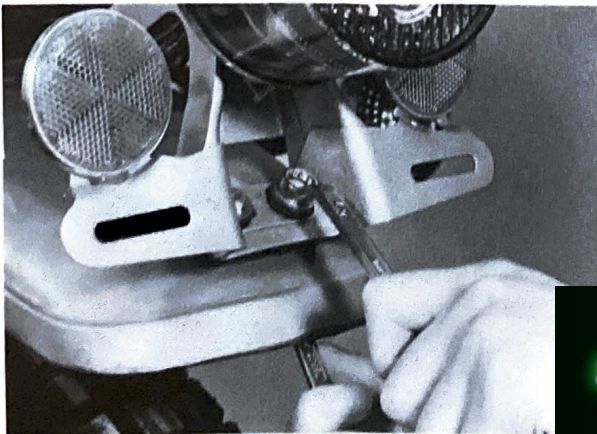

Fig. 39

25. a. Remove the taillamp assembly holding bolt from the taillamp license bracket.
- b. Connect the lead wires of the taillamp ass'y and secure them with the hook. (The lead wires of the same color must be connected to each other.) (Fig. 36) (Fig. 37)

26. Secure the front part of the license bracket using the bolt washer with cover, fender mounting collar. (Fig. 38)

27. Secure the rear part of the license bracket using two shoulder bolts, plain washers. (Fig. 39)

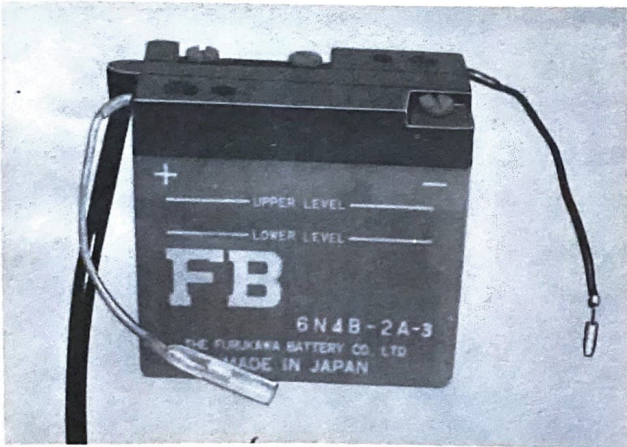

Fig. 40

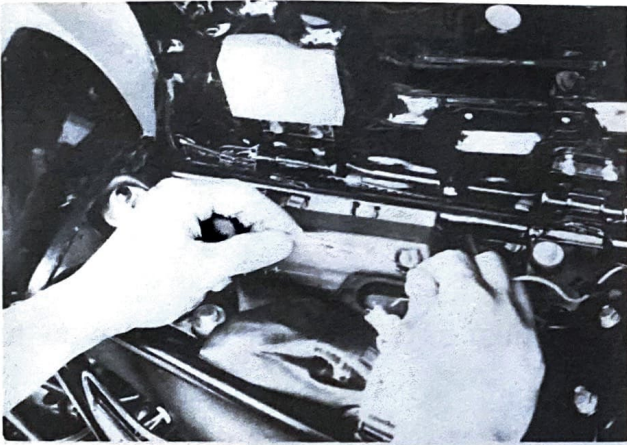

Fig. 41

28.
  - a. Remove the battery band.
  - b. Connect the breather pipe to the battery.
  - c. Remove the battery fill plugs.
  - d. Blow gently through the breather pipe to check for proper internal ventilation.
  - e. Fill each battery cell to the top level line with electrolyte. (Diluted sulphuric acid-specific gravity = 1.260) Take battery to well-ventilated area.
  - f. Place battery on trickle charger (maximum rate of charge = 0.4A), and charge for 10 hours at 6 ~ 7V or until specific gravity within each cell reaches 1.260 at 20° C.
  - g. Clean battery, refill cells, if necessary, and install fill plugs.
  
29.
  - a. Make sure the main switch is in the "OFF" position.
  - b. Install the battery within the battery box. Connect the positive and negative lead wires to the battery. Make sure the negative lead wire is properly grounded.
  - c. Route the breather pipe between the rear fender and the swing arm. Make sure its exit point is away from any of the machine.
  - d. Install the battery securing strap.

[www.legends-yamaha-enduros.com](http://www.legends-yamaha-enduros.com)

Starting at the front of the unit, inspect the following fittings, mounts, and fasteners for correct installation and fastener torque:

1. Front wheel spoke tightness.
2. Front wheel rim deflection and runout.
3. Front wheel tire pressure.
4. Front wheel axle nut, cotter pin.
5. Front wheel axle holder securing nuts.
6. Front fork securing bolts.
7. Steering head lock nuts.
8. Handlebar holder securing bolts.
9. Handle lever, and throttle ass'y mounts.
10. Engine mounting bolts.
11. Cylinder head securing nuts.
12. Carburetor mounting flange screws.
13. Foot rest mounts.
14. Change pedal securing bolt.
15. Brake pedal mount and actuating mechanism.
16. Rear fender and taillight mounts.
17. Rear shock (cushion) mounting nuts.
18. Rear swing arm pivot securing nuts.
19. Rear axle lock nut and cotter pin.
20. Chain adjust bolts and lock nuts.
21. Rear wheel spoke tightness.
22. Rear wheel rim deflection and runout.
23. Rear wheel tire pressure.

THIS CONCLUDES THE ASSEMBLY PORTION. HOWEVER, THE UNIT MUST STILL BE "SET-UP" FOR DELIVERY TO THE CUSTOMER.

For specifications regarding ignition timing, carburetor adjustment, tire pressures, engine oil type and quantity, etc. Refer to appropriate sections of DT250A/360A service manual.

[www.legends-yamaha-enduros.com](http://www.legends-yamaha-enduros.com)

# CABLE ROUTING DIAGRAMS

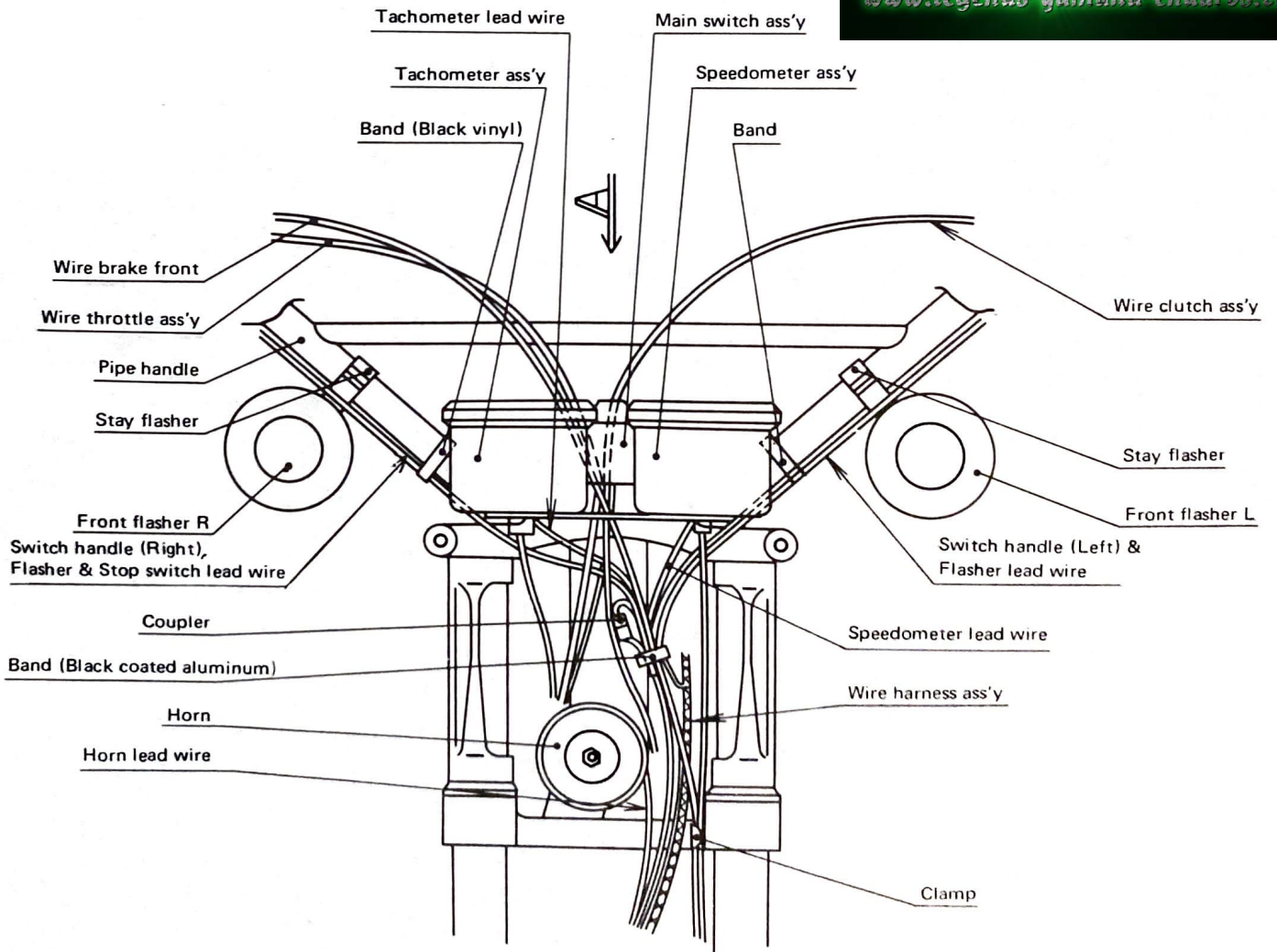
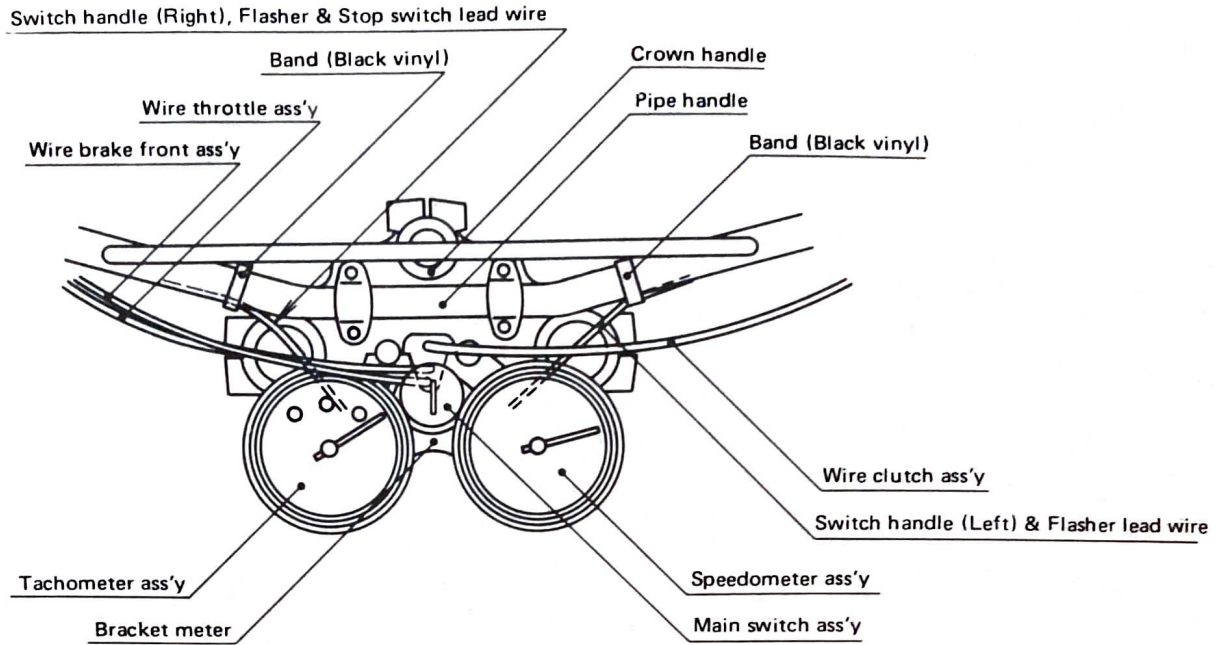



## CABLE ROUTING DIAGRAMS

**Part A View**

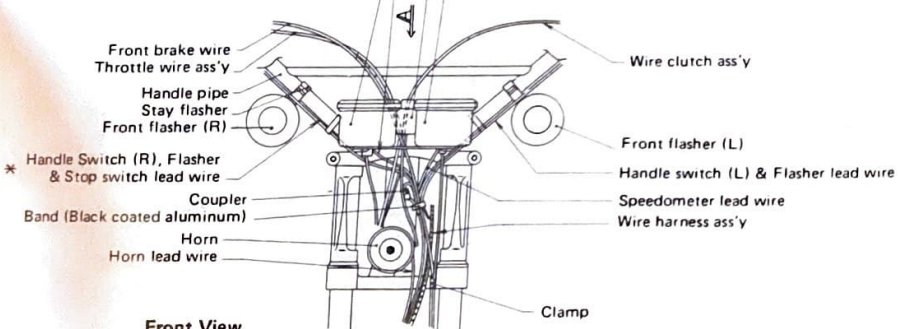
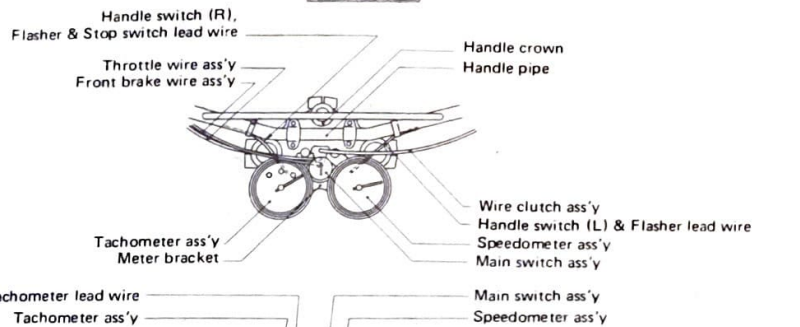

**Front View**

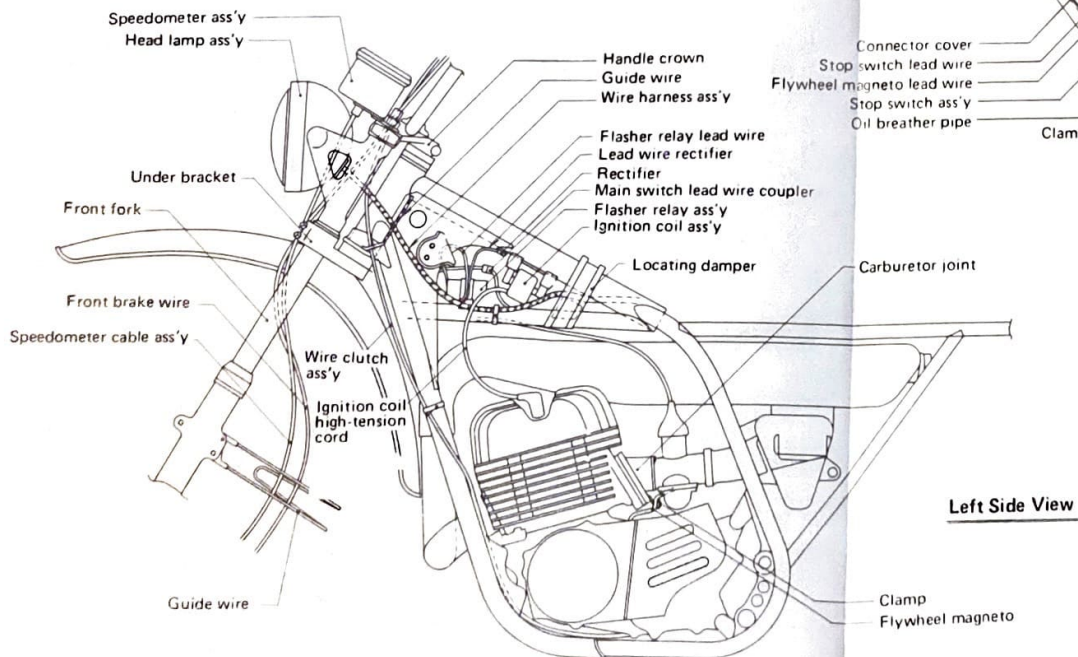

**Left Side View**

**Top View**

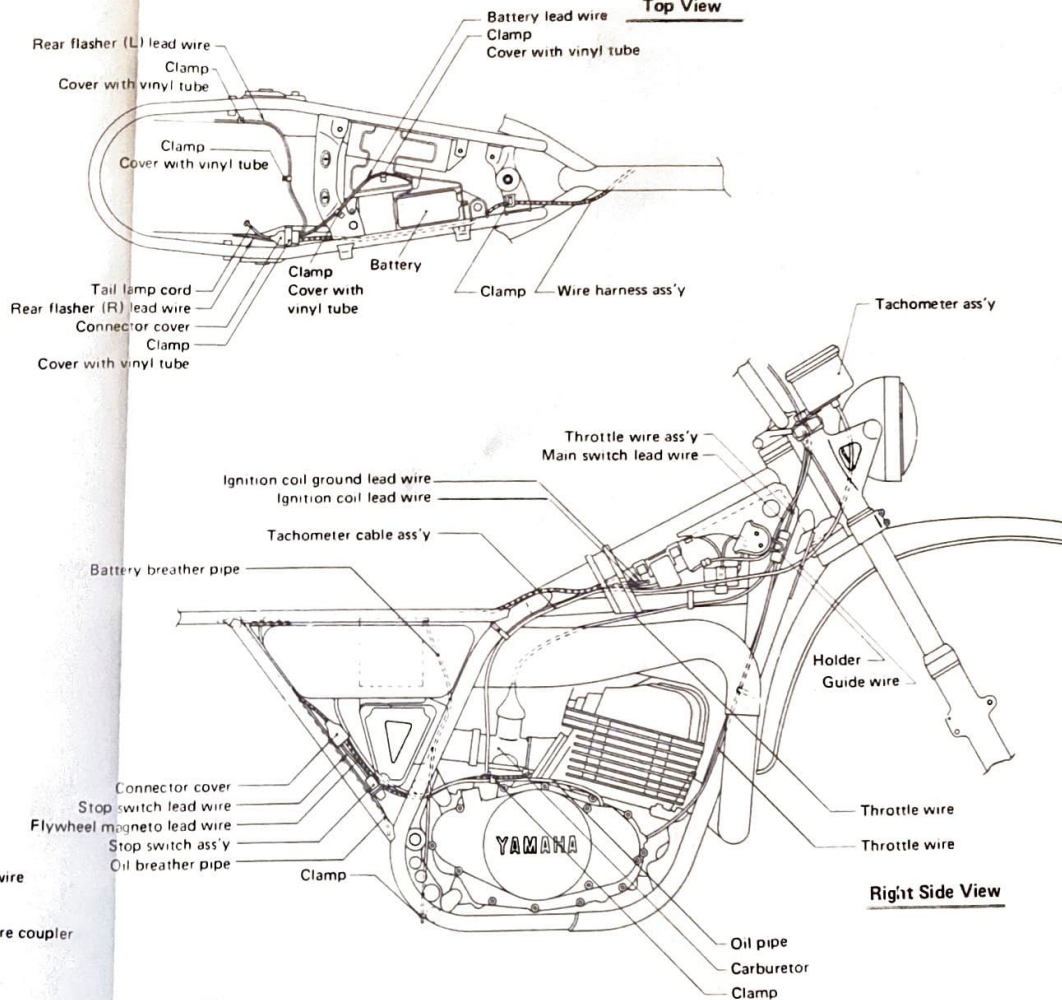

**Right Side View**



\* **Note:**  
 Connect the stop switch lead wire to the harness of lead wire in the head lamp body.



[www.legends-yamaha-enduros.com](http://www.legends-yamaha-enduros.com)



SINCE 1887

**YAMAHA MOTOR CO., LTD.**

IWATA, JAPAN

PRINTED IN JAPAN  
73 · 7 · 3.0 x 1 (G)

LIT-11664-38-00