

YAMAHA

MX

175A

OWNER'S MANUAL

www.legends-yamaha-enduros.com

455-28199-10

Congratulations! You are now the owner of a new Yamaha MX175A. The MX175A is a highperformance, motorcycle manufactured by the leading manufacturer of motorcycles in Japan.

The MX175A the newest and top of the Yamaha line models is designed for competition. It features a rugged, powerful, C.D.I. ignition, 2-stroke single cylinder, reed valve engine, and Autolube, the revolutionary lubricating system developed by Yamaha Technical Research Laboratory and proven in all Yamaha models.

This manual explains some steps necessary for operating and caring for your new motorcycle. Please read it carefully to become thoroughly familiar with all the features and advantages built into your MX175A



CONTENTS

Information	1
Contents	2
Profile	3
What you should know	5
Engine Stop Button	6
How to Start the Engine	6
How to Stop the Engine	7
Break-in	8
Checking and Service Racing	9
Setting to be made at a Racing Circuit	9
Tire Pressure Adjustment	13
Rear Cushion Adjustment	13
Selection of Secondary Reduction Ratio	14
Inspection and Adjustment	15

PROFILE

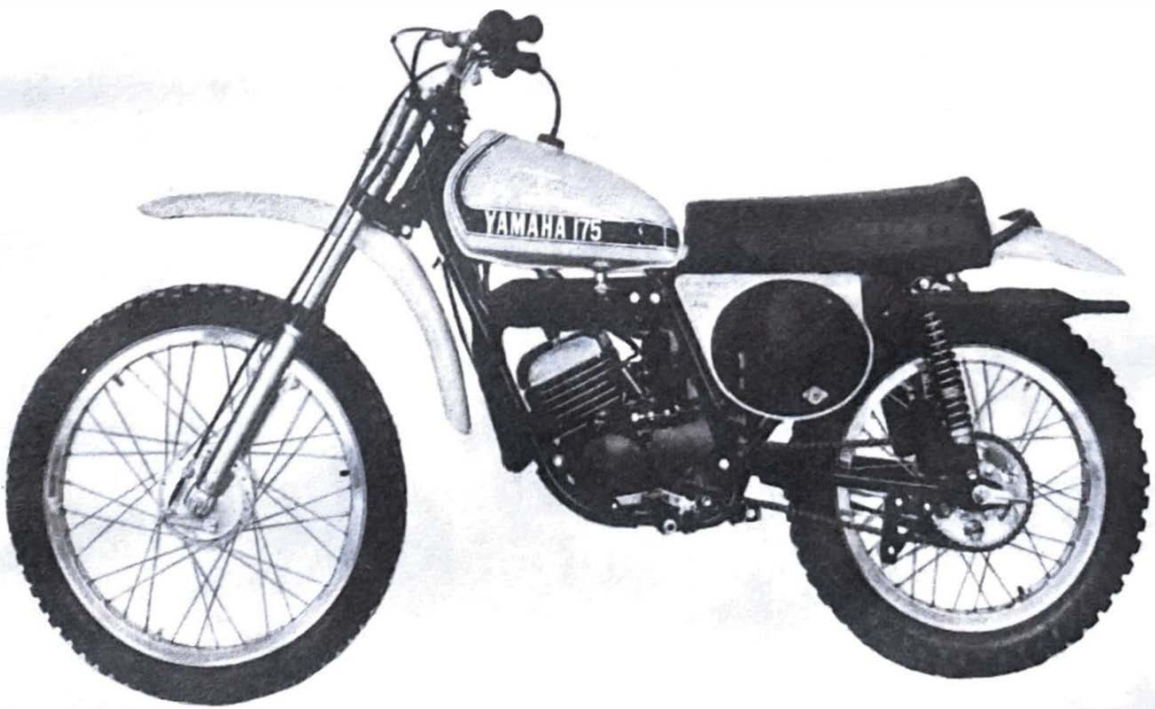

Left hand side

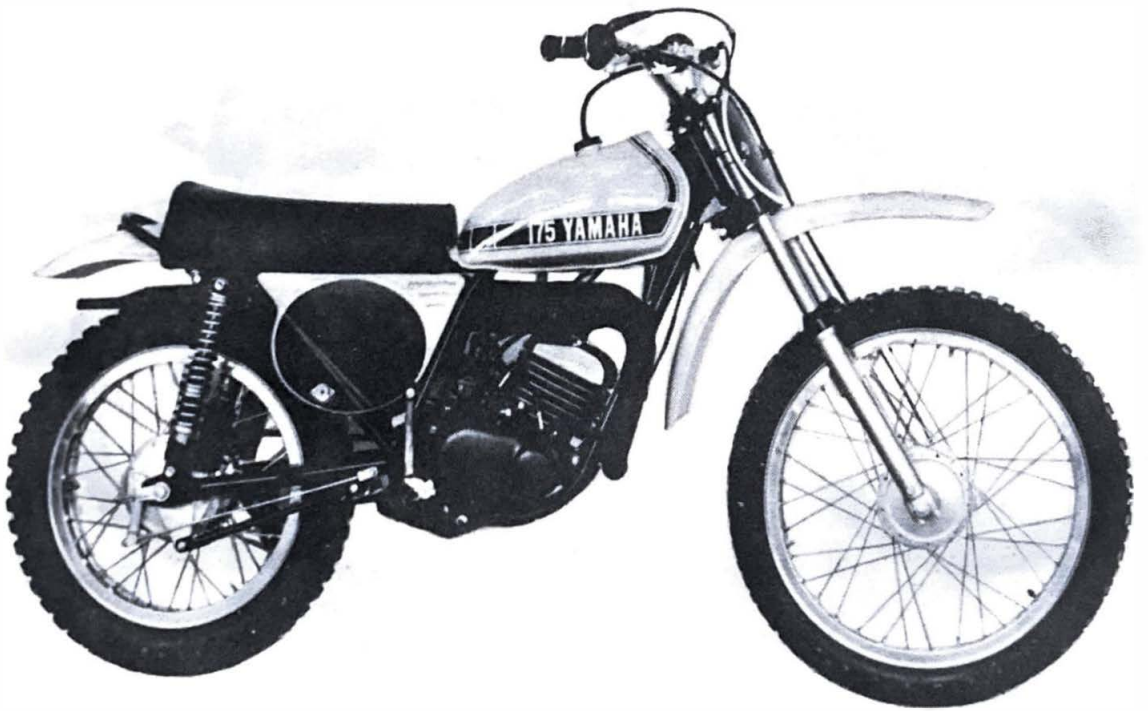

Right hand side

1. What you should know

For the MX175A a gas-oil mixture should be used.

The recommendable gas and oil and mixing ratios are as specified below:

Gasoline	High octane gasoline
Oil	Shell super M, Castrol R-30 Penta lube RX700
Mixing ratio	With Autolube pump used: 30 : 1 With Autolube pump removed: 15 : 1

Note: The pre-mixed gas-oil mixture will become inferior in lubricating property 24 hours after preparation. Avoid using any mixture remaining in the fuel tank.

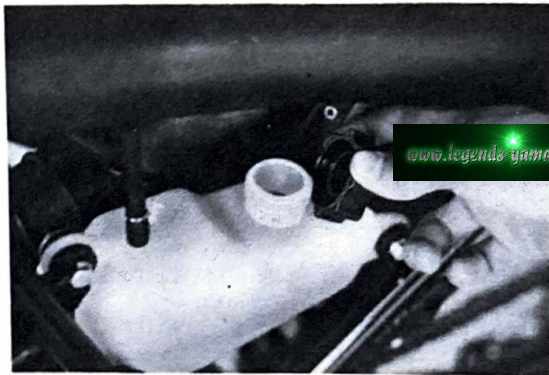
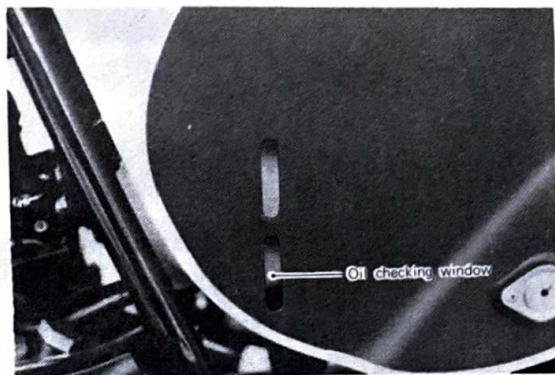

2. Engine Stop Button

This safety device is used when your machine is upset or when you need to stop the engine quickly.

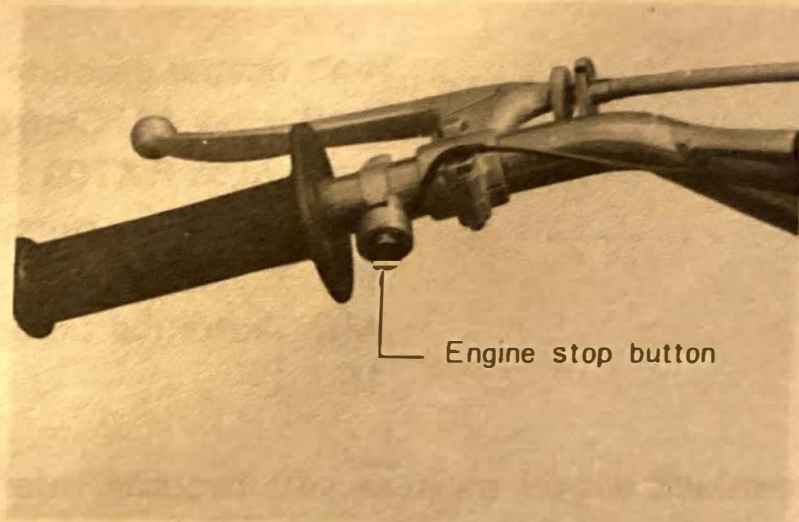

3. How to Start the Engine

(When the engine is cold)

- a. Replace the spark plug with a hotter type (B-7ES or 8ES) for warming up.
- b. Open the fuel petcock.
- c. Push down the starter lever, and fully close the throttle valve. Then, kick the kick crank hard.
- d. After starting the engine, keep it run for a few minutes for warming up. Then, replace the spark plug with the regular type.

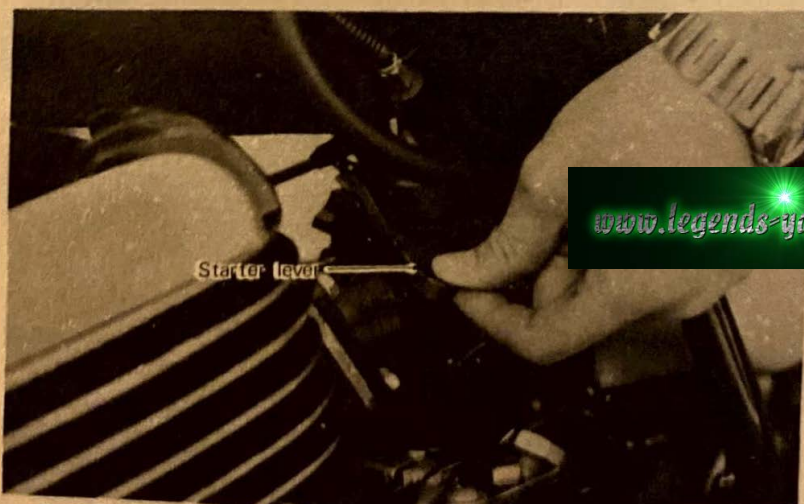

www.legends-yamaha-enduros.com

(When the engine is warm)

Slightly twist the accelerator grip, and kick the kick crank hard.
It is unnecessary to replace the spark plug.

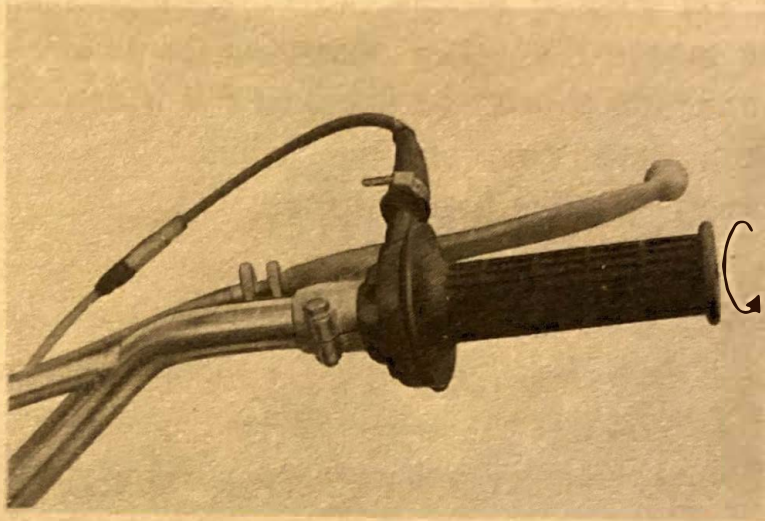

4. How to Stop the Engine

The motocrosser or the scrambler are not equipped with the main switch, but the MX175A is provided with the engine stop button. By depressing the engine stop button, the engine can be stopped, whenever required.

Besides, you can stop the engine without using the engine stop button. First, disengage the clutch, and apply the rear brake at any gear position (except neutral). Release the clutch lever, and the engine will come to stop.

Note:When stopping the engine, take care so that the spark plug will not get wet with the fuel. Make it your habit to close the fuel petcock after stopping the engine.

5. Break-in

Your brand new machine has to be broken in at least for 10 miles. If breaking in the machine is improper, the result may be: (1) Engine noise, (2) Engine seizure, (3) Engine power loss, and (4) Shorter engine service life. After observing the break-in in a correct manner, the machine should be checked for frictional contact between the piston, piston rings and the cylinder. You will end up with a smooth-running, trouble-free machine.

How to Break-in the Machine

Operation:

0
↓
10 MILES, YOU SHOULD KEEP THE THROTTLE OPENING
BELOW HALF IN EACH OF THE GEARS.

Checking:

Remove the cylinder, and check the cylinder wall, piston and piston ring for scratches and contacts between them. If any high spot or any scratch is found, it should be smoothed out with sandpaper (#600). If the scratch by a ring is excessive, replace the ring.

Operation:

10 MILES,
↓ THE MACHINE CAN BE RUN WITH FULL
THROTTLE.

6. Checking and Service Racing

To keep the machine run a race in top condition, routine check-ups and service are very important. Before a race, the following check-ups should be made:

1. Check and adjust the brakes.
2. Check and adjust the clutch.
3. Clean the air cleaner element.
4. Check and adjust the ignition timing.
5. Remove the carbon from the cylinder, cylinder head, and piston, and check the cylinder wall for scratches and high spots.
6. Check the gear oil, and if necessary, replace it.
7. Check the spokes for looseness, and if necessary, retighten them.
8. Lubricate the drive chain, etc.
9. Retighten bolts and nuts.

7. Setting to be made at a Racing Circuit

Whether you will win a race or not depend on your driving skill and your machine performance. It will not be easy for you to snatch a victory in any race, because the performance of your machine will be affected to a large extent by conditions of the racing course, weather and the like.

To keep your machine run at best condition, the machine must be so adjusted as to best suit to the racing course.

a. Selection of Spark Plugs

Standard spark plug is recommended, but you may have to change the spark plug depending on the conditions of running and racing circuits.

Remember that for warming up the engine, hotter type spark plug should be used, and a few minutes of warming up is needed.

After the warming up, replace the spark plug with that you have selected.

Colder type. If the standard type spark plug is found running too hot and white, replace it with a colder type.

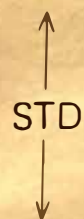

Hotter type If the standard type spark plug is found sooty and oily, replace it with a hotter type.

Heat Range	NGK	Champion	Autolite	Bosch	KLG	Lodge	
Hotter ↑	B-8EN(P)	N62R	AG23	W240T17	FE220	RL47	
	B-85EN(P)	N60R	AG903	W270T17			
	B-9EN(P)	N57R	AG603	W290T17	FE260	RL49	
	B-95EN(P)			W310T17		RL50	
				W340T17			
	B-10EN(P)	N54R	AG403		FE280	RL51	
				W370T17			
	B-105EN(P)						
	B-11EN(P)			AG203	W400T17	FE310	RL52
	Colder ↓	B-12EN(P)	N52R	AG103	W440T17	FE340	RL53

b. Carburetor Adjustment

Carburetor settings should be determined according to the burning condition of the spark plug. Generally speaking, a motocrosser is run with full-throttle, and therefore, the carburetor main jet greatly affects the performance of the engine.

- When the spark plug is in a tan color:
Best. That is, the carburetor settings are the most suitable for the condition of the racing circuit, weather, and operation.
- When the electrodes are white:
The spark plug runs too hot. In this case, the main jet should be replaced with a larger one.
- When the electrodes are sooty and oily:
If the electrodes are sooty and oily, the main jet should be replaced with a smaller one.
- * The larger the main jet calibration No., the more the gasoline is supplied. The calibration Nos. are designated as follows:
Up to No.100 Calibrated by 5
Over No.100 Calibrated by 10

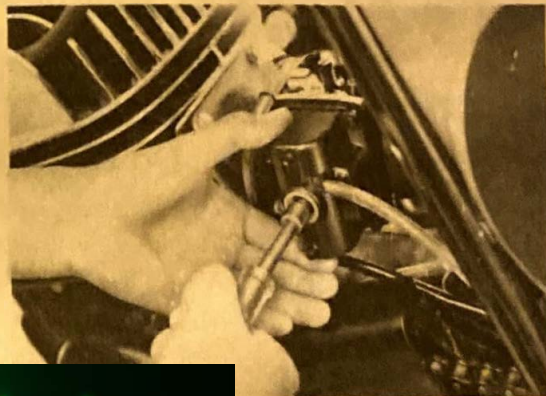

www.legends-yamaha-enduros.com

After replacing the main jet, check the engine operating condition in the following manner. Rapidly open the throttle valve, and observe the increase of the engine speed. If the speed will not increase smoothly, showing irregularity, the position of the jet needle must be changed.

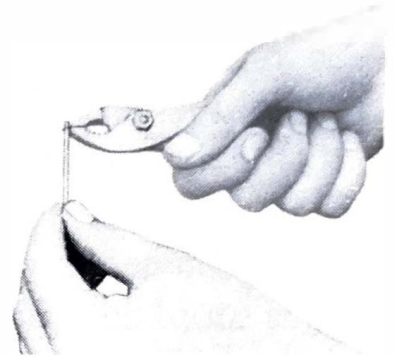
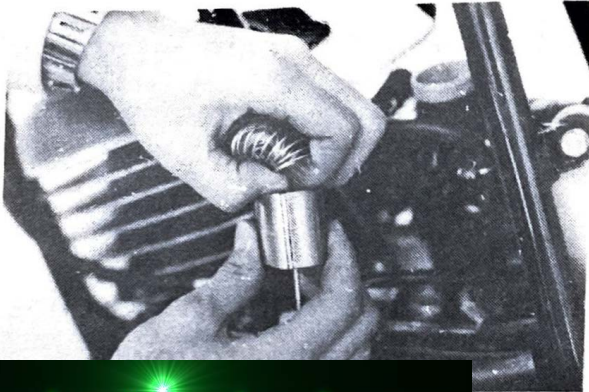
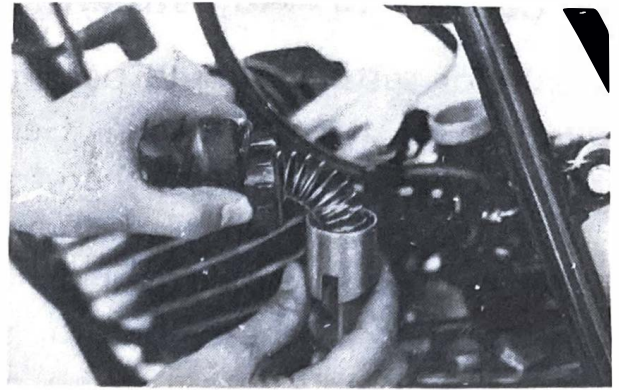
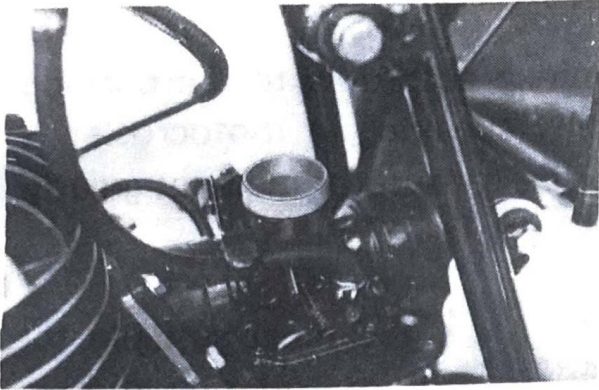

www.legends-yamaha-enduros.com

The position of the jet needle affects the increase of the engine speed in the range of medium to high.

Note:When you select the carburetor main jet, start with a larger one for testing. Do not begin with a smaller one.

8. Tire Pressure Adjustment

Tire pressures are determined depending on the condition of the racing circuit and the choice of the rider.

If the racing course is rough with many pebbles, low tire pressures will result in damage to the tire rims.

9. Rear Cushion Adjustment

The rear cushion can be adjusted in five ways according to the rider's choice.

Note: It is not advisable to remove the rear cushion oil tank cap for oil replacement, because it may damage the cushion.

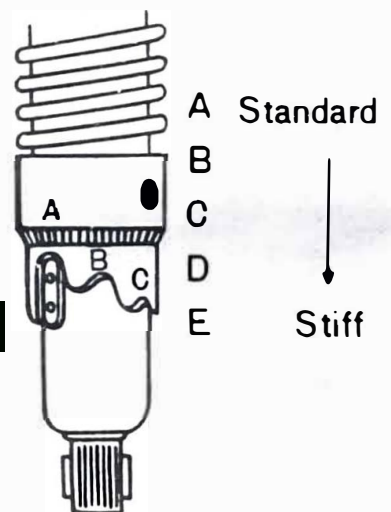
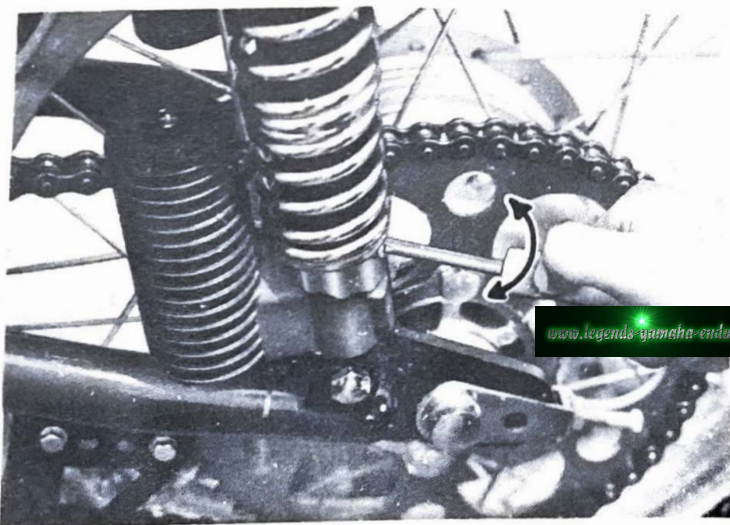

10. Selection of Secondary Reduction Ratio

The secondary reduction ratio must be selected according to the racing circuit condition-bumpy or smooth.

To enable the rider to select the most suitable reduction ratio, a variety of drive sprockets and sprocket wheels are available.

11. Inspection and Adjustment

1. Clutch

If the clutch is adjusted improperly, it may drag or slip. It should be adjusted periodically (particularly before racing).

Adjustments

- Fully tighten the adjusting screw attached to the clutch lever.
- Adjust the play of the clutch lever to 2-3 mm by turning the clutch lever adjusting screw.
- After the adjustment, tighten the lock nut.

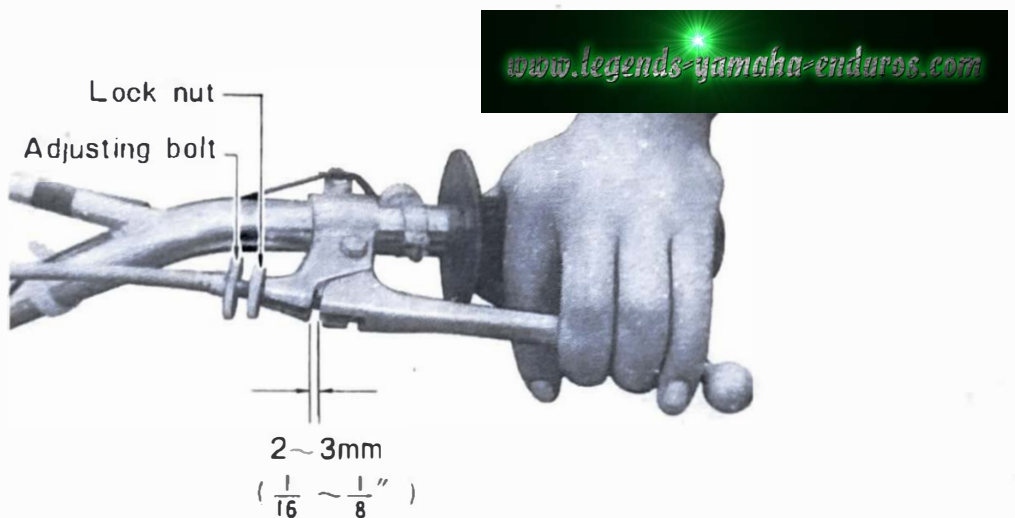

2. Brake Adjustment

To allow the brakes to operate effectively and accurately, the front brake lever should have a play of 5-8 mm, while the rear brake pedal a play of 20-25 mm.

How to Adjust the Brakes

Front Brake

- Adjust the brake lever to 5-8 mm by turning the brake adjusting bolt.
- For easy adjusting, the front brake can be adjusted by brake lever adjusting bolt.
- After the adjustment, be sure to tighten the lock nut.

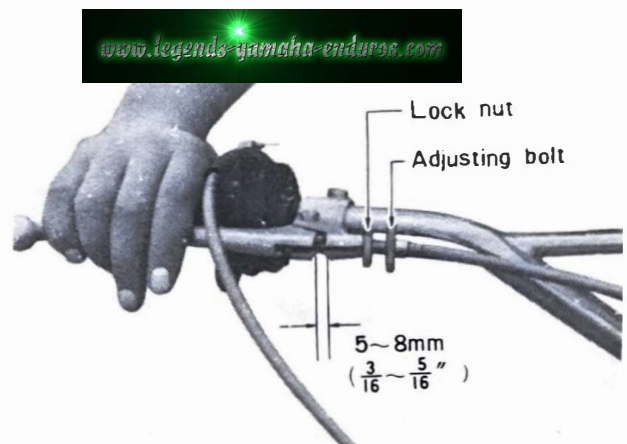
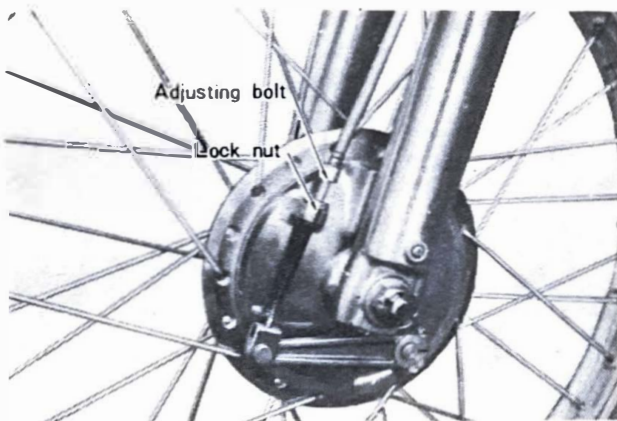

Rear Brake

- Adjust the brake pedal with the rear brake adjusting nut so that the pedal will have a play of 20-25 mm.

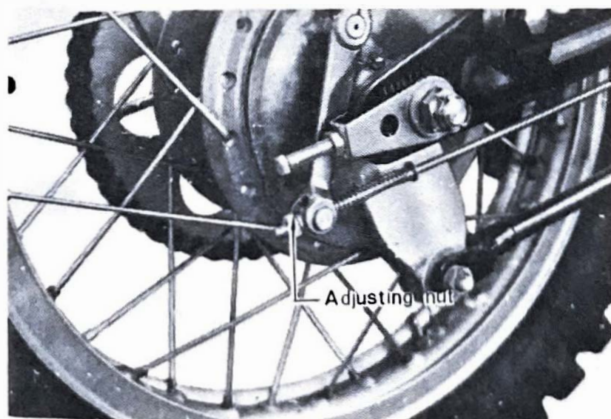

3. Adjusting the Ignition Timing

The MX175A employs the C.D.I for ignition.

- a. Remove the spark plug, and install a dial gauge in the spark plug hole.
- b. Turn the crankshaft to the left and locate TDC.
(When the dial gauge pointer begins to turn in reverse, the piston is at about TDC.)
- c. When TDC is located, turn the dial and set "0" to the pointer.
- d. Turn the crankshaft to the right, and when the dial gauge pointer indicates 2.0 mm before T.D.C. check to see if the mark on the rotor aligns with the mark on the pulser. If they aligns with each other, the ignition is correct.
- e. Adjustment can be made by moving the pulser.

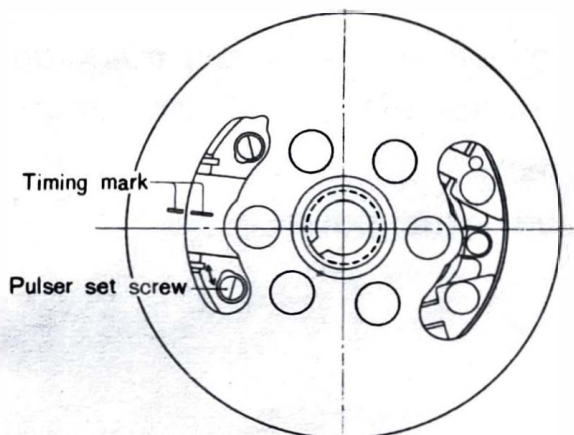
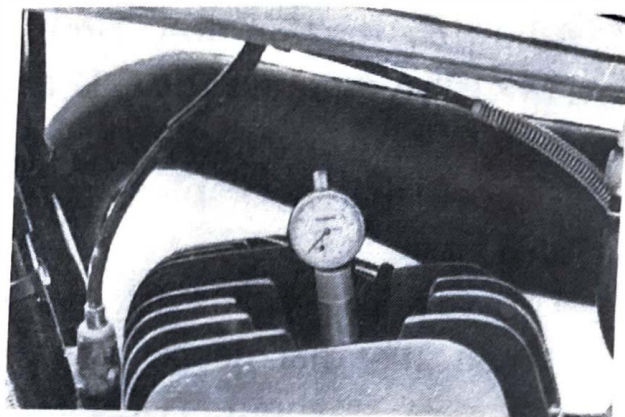
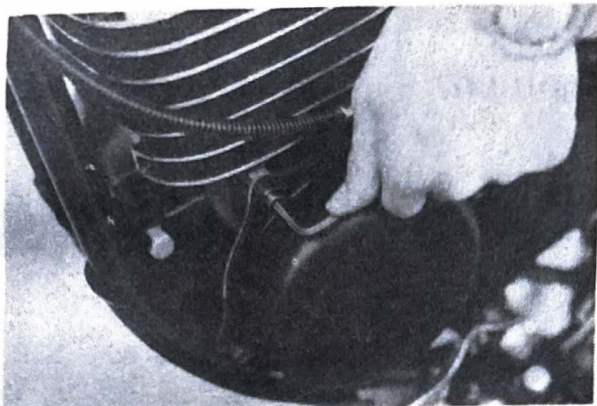

4. Cleaning the Air Cleaner Element

If the air cleaner element is clogged with dust, the performance of the air cleaner will be greatly reduced. Particularly, the air cleaner on a motocrosser tends to be dirty quickly. It should be cleaned as often as possible.

Removing the Air Cleaner Element:

- a. Remove the seat and cleaner case cap.
- b. Take out the element.

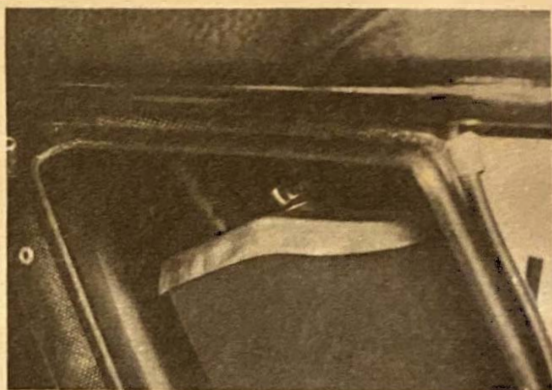
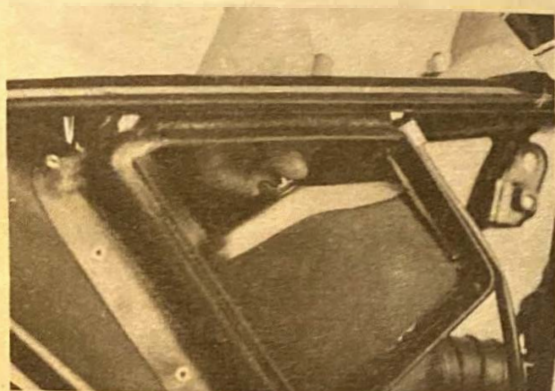

5. Washing

The element removed should be washed thoroughly with an oil mixture and installed after fully squeezed.

6. Checking and Replacing the Gear Oil

Check the gear oil for its level. It should be within the specified range of levels.

Gear oil MOTOR OIL SAE "SE" 10W/30

Amount 650 ± 50 cc

The gear oil tends to deteriorate after a long time of use. It is advisable to replace the gear oil for each race, because the engine will be placed under severe operating condition.

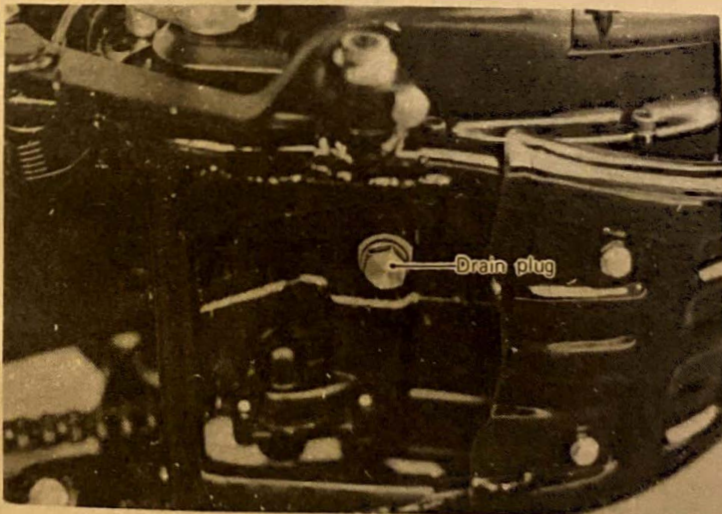
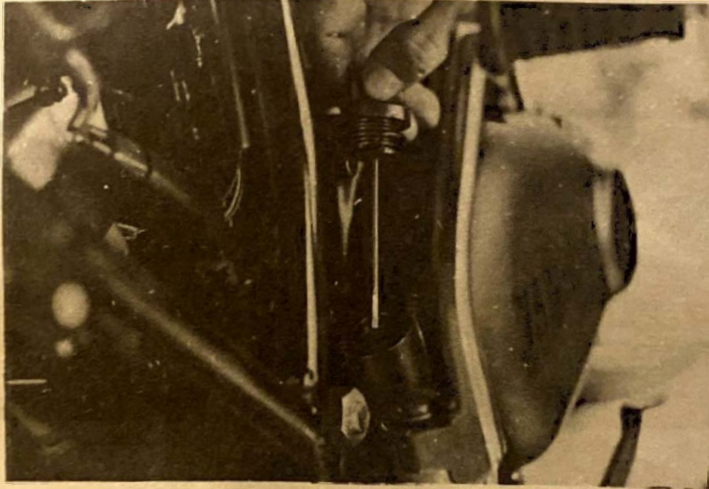

7. Checking the Cylinder and Piston Ring for contact

After the first 10 miles of operation, the contact between the cylinder and piston ring should be checked.

If necessary, any irregularity should be corrected.

- a. Remove the muffler.
- b. Remove the cylinder head nuts.

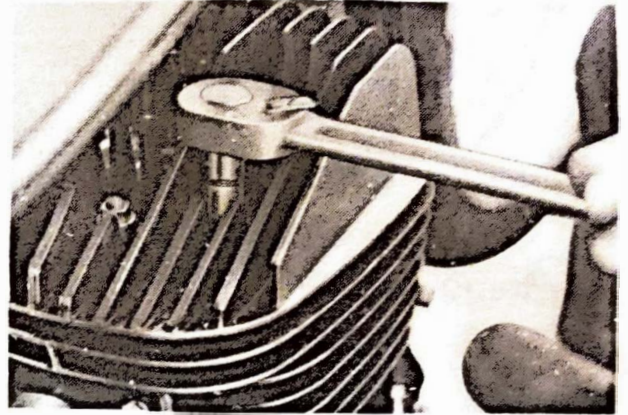
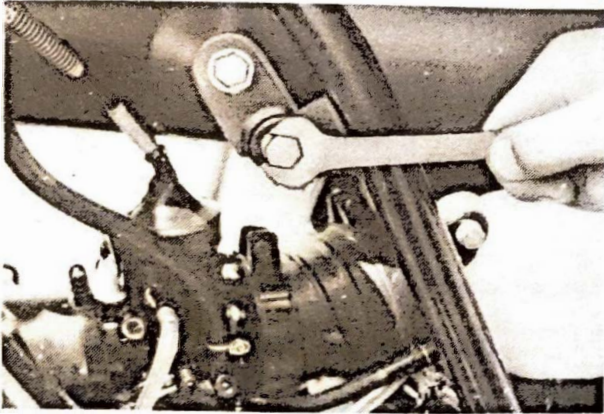

- c. Remove the cylinder head.
- d. Remove the delivery pipe.

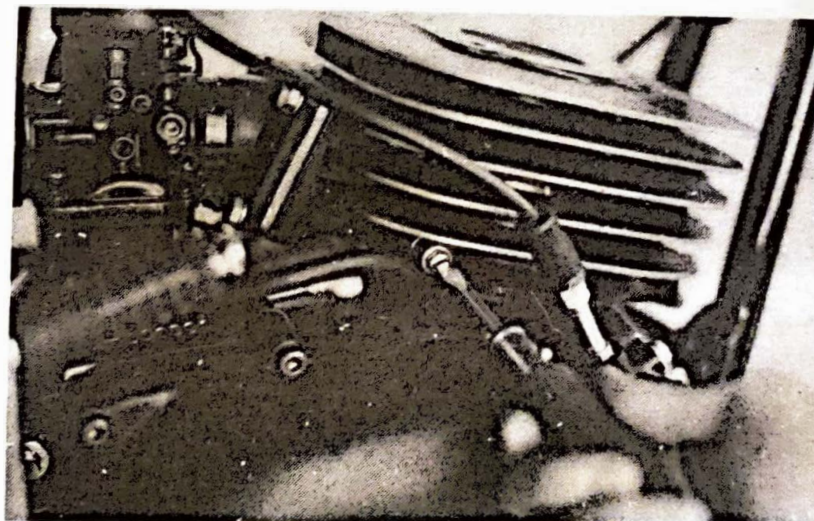

e. Loosen the air cleaner joint band.

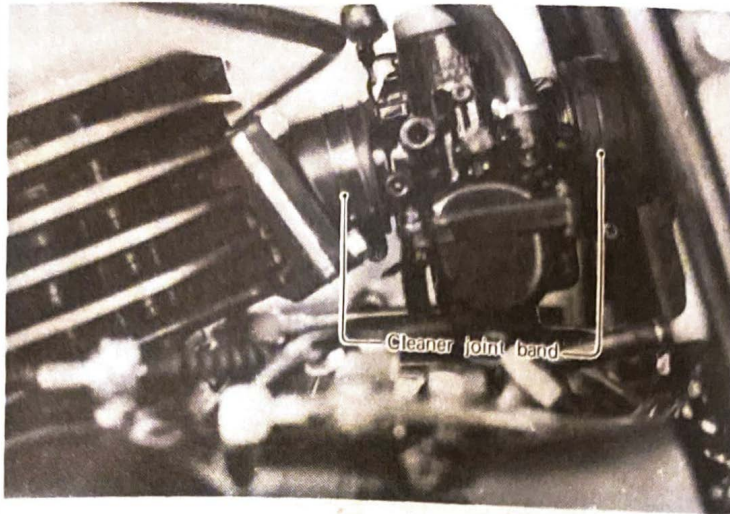

f. Remove the carburetor.

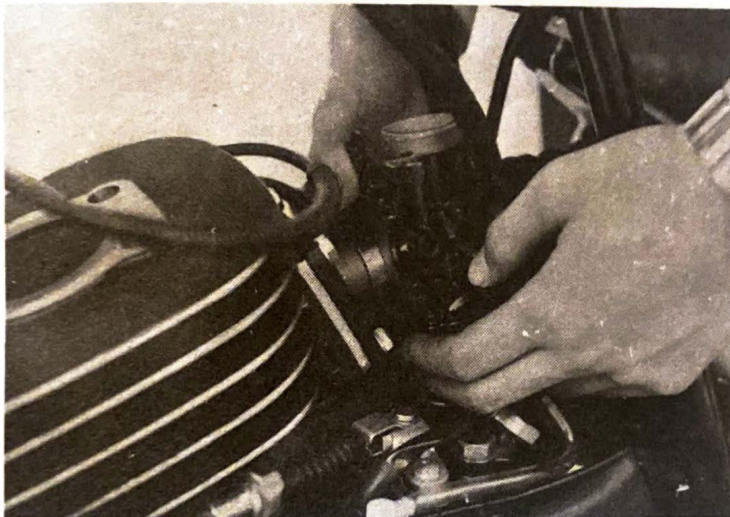

g. Remove the four cylinder mounting bolts so cylinder can be removed.

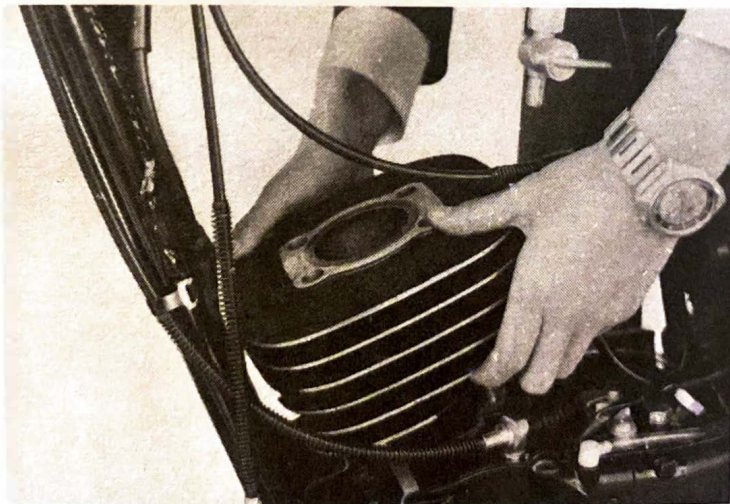

- h. Cover the crankcase with a cloth, and remove the piston clip with a screwing motion.

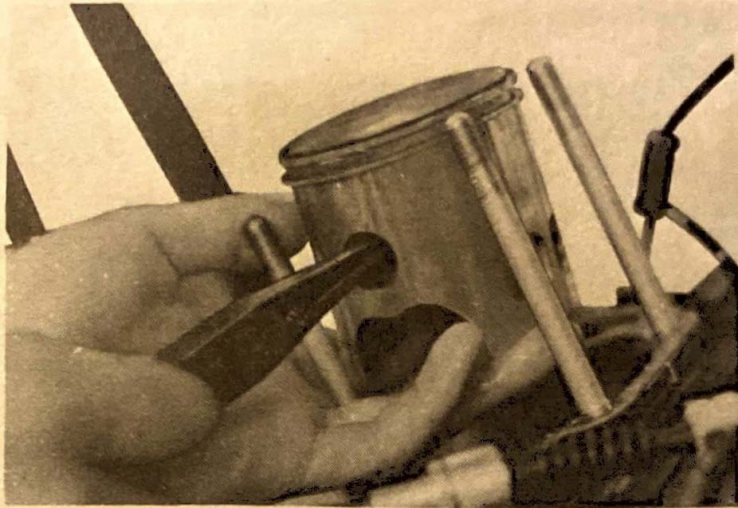

- i. Push out the piston pin, and remove the piston.
(Take care not to drop the small end bearings.)
- j. Check the piston, piston ring and cylinder wall for scratches and high spots.
High spots are bright, and should be smoothed out with oil stone of fine sandpaper.

www.legends-yamaha-enduros.com

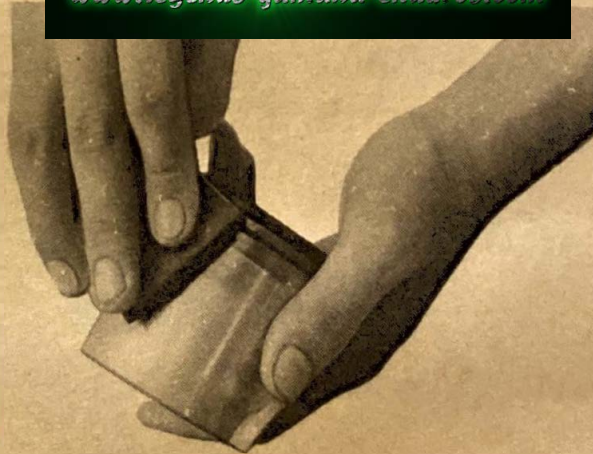

- k. If any piston ring is found stuck or scratched, it should be replaced.

8. Installation

a. Install the piston ring.
Make sure that the ring locating pin is between the ends of the ring.

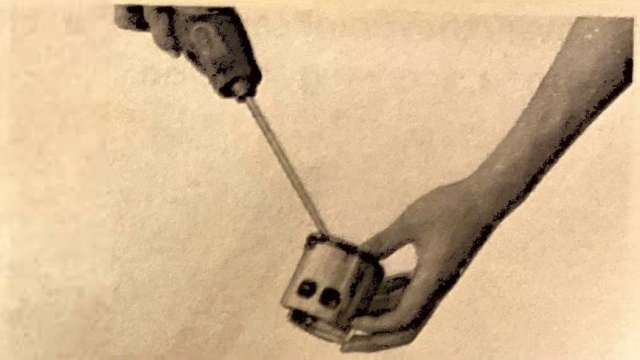

b. Oil the small end bearing, cylinder etc.

c. Cover the crankcase with a cloth.

Be sure to install the piston with the arrow mark (stamped on the piston head) pointing to the exhaust port side.



d. Tighten the cylinder head nuts cross-pattern and in separate steps. Tighten torque must be correct.

Note: Each time the cylinder is removed, use a new cylinder gasket and cylinder head gasket.

Other gaskets should be thoroughly cleaned.

e. Removing the Carbon from Cylinder Head, Cylinder and Piston.

The cylinder should be disassembled in the manner (Refer to page 21 ~ 23.) and remove the carbon.

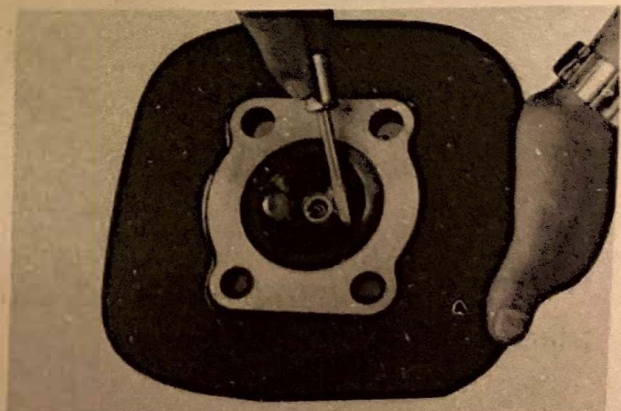

f. Checking the Spokes for Looseness

Check the spokes for looseness by tapping them one by one with a wrench. Any loose spoke should be tightened.

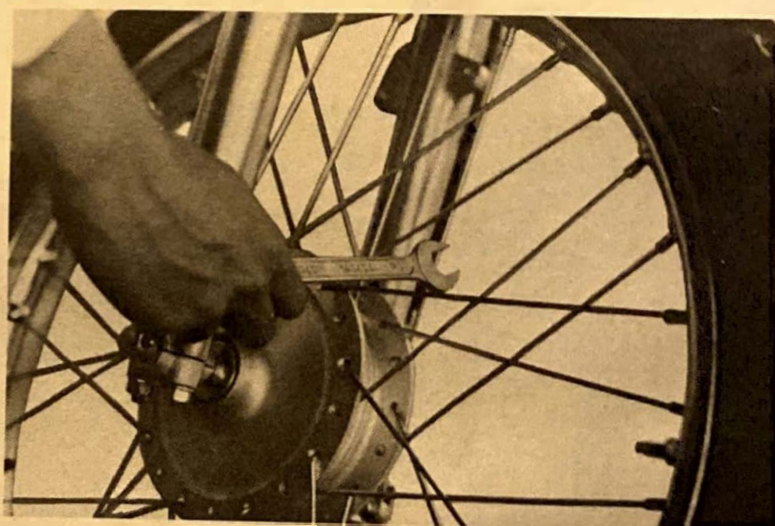
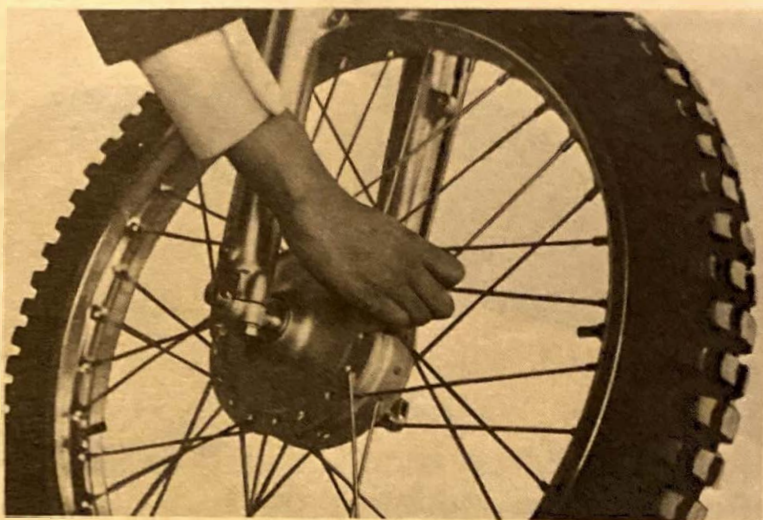

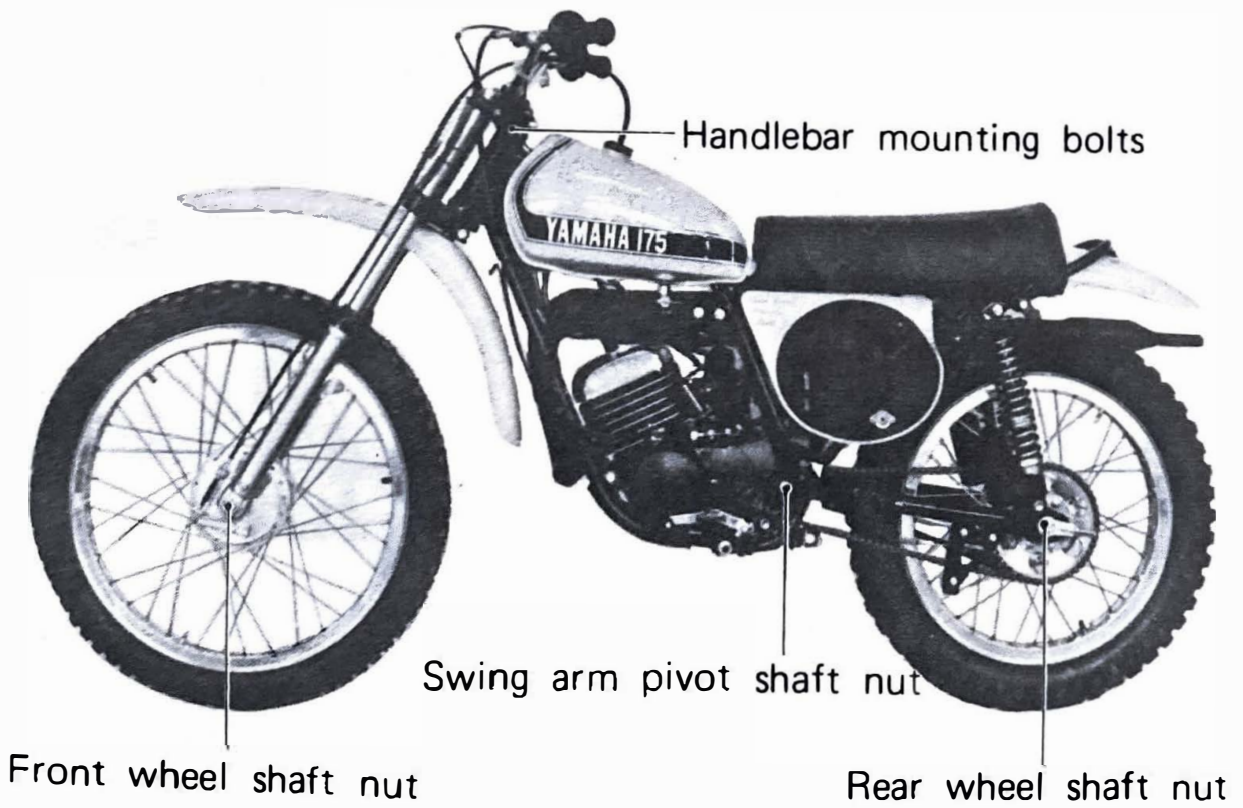
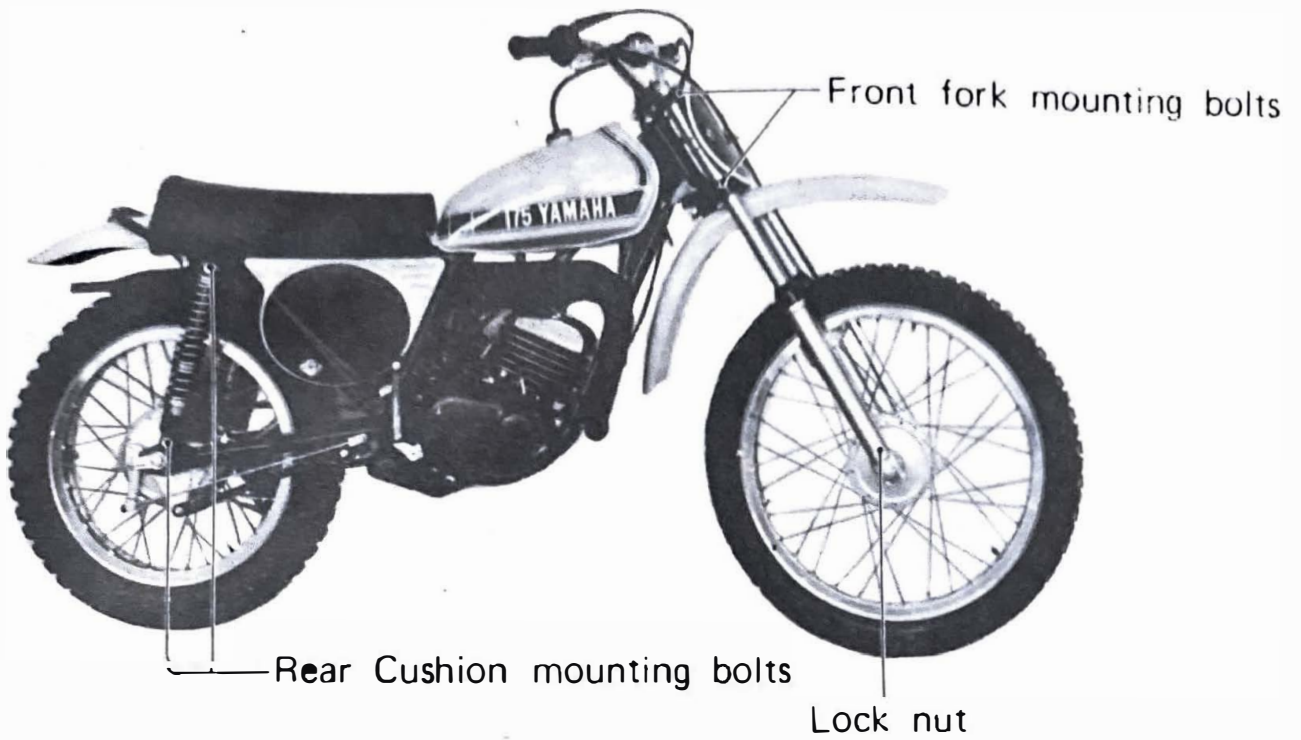

h. Lubricating the Drive Chain

If the drive chain lacks oil, it tends to stretch quickly and shorten its service life. Engine power loss will also result. It should be lubricated periodically.

i. Adjusting the Drive Chain

The drive chain must have an up-and-down movement of 20 mm at the center of the drive chain with the rear wheel on the ground. Adjustment should be in the following manner.

1. Loosen the rear brake adjusting nut.
2. Remove the cotter pin and loosen the rear wheel shaft nut.
3. Loosen the chain adjusting puller lock nuts.
4. Tighten the chain adjusting puller bolts so that the drive chain deflects 20 mm at its center.

The chain adjusting puller bolts both right and left, must be positioned evenly.

5. Tighten the rear wheel nuts and other bolts and nuts.
6. Be sure to bend the cotter pin ends.
7. Adjust the rear brake.

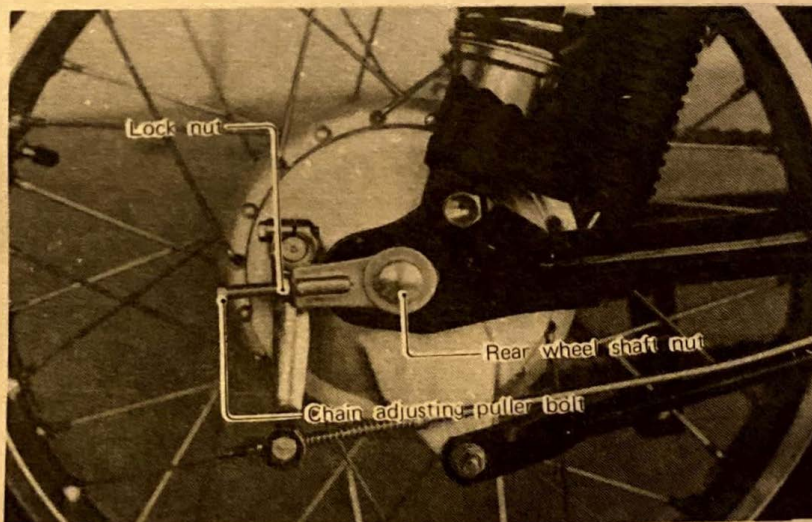

www.legends-yamaha-enduros.com



SINCE 1887

YAMAHA MOTOR CO., LTD.

IWATA, JAPAN

LIT - 11624 - 55 - 00

Printed in Japan

'73- 9.5.0 x 1 