



**YAMAHA**

**DT125E/DT175E**

**ASSEMBLY MANUAL**



90894-07729

## FOREWORD

This motorcycle may be equipped for general off road use. It may be illegal to operate this vehicle off-road when it is equipped for competition use.

Check your state and local riding area regulations. This vehicle is not manufactured for use on public streets, roads or high ways. Such use is prohibited by law. An off-road riding kit is provided with each vehicle to comply with noise level and spark arrester laws and regulations for installation instructions see directions in this manual.

Performance will be substantially decreased. Retuning is not required.

## NOTICE

The service specifications given in this Assembly Manual are based on the model as manufactured. When this model may require improvements, the service specifications may be subject to change in the future. Modifications are inevitable and significant changes in specifications or procedures will be forwarded to Authorized Yamaha dealers. The assembly procedure is described in the order that the mechanic should follow, and the correct service tools should be used in the correct manner. Failure to do this may result in poor performance and harm to the rider.

Particularly important information is distinguished in this manual by the following notations:

**NOTE:** . . . . .A NOTE provides key information to make procedures easier or clearer.

**CAUTION:** . . .A CAUTION indicates special procedures that must be followed to avoid damage to the machine.

**WARNING:** . . .A WARNING indicates special procedures that must be followed to avoid injury to a machine operator or person inspecting or repairing the machine.

YAMAHA DT125E/DT175E  
ASSEMBLY MANUAL  
1st EDITION, MARCH 1977  
OVERSEAS SERVICE DEPARTMENT  
YAMAHA MOTOR CO., LTD.  
IWATA, JAPAN  
LIT-11666-00-70

## PREPARATION

To assemble the machine correctly, the following service tools, supplies and working space are required:

## UNPACKING

### Note on transportation

Use care not to butt the machine packed in the crate against a hard object or give it a heavy shock during transportation or in the service shop.

### Procedure for unpacking

To remove the machine and parts packed in the cardboard crate, cut the vinyl bands around the box using a cutter or scissors. Next, remove the exterior carton by lifting it straight up.

Remove the foam tray, front wheel and seat. Next, remove the nails from each corner of crate, and remove the struts.

Remove the front fender and double seat.

3	1	Taillight assembly
4	1	Front brake shoe plate assembly
5	1	Front flasher light (R)
6	1	Front flasher light (L)
7	1	Rear flasher light (R)
8	1	Rear flasher light (L)
9	1	Rear licence plate
10	1	Rear reflector
11	1	Speedometer cable
12	1	Front brake cable
13	1	Vinyl bag
14	1	Right foot rest
15	1	Left foot rest
16	1	Battery assembly
17	1	Owner's manual
18	1	Service tool assembly
19	1	Wire holder 1
20	1	Wire holder 2
21	1	Rear view mirror
22	1	Fuel tank breather pipe

### Check list

Set position	Q'ty	Parts name
A	1	Foam styrol case
B	1	Front wheel
C	1	Front fender
D	1	Seat

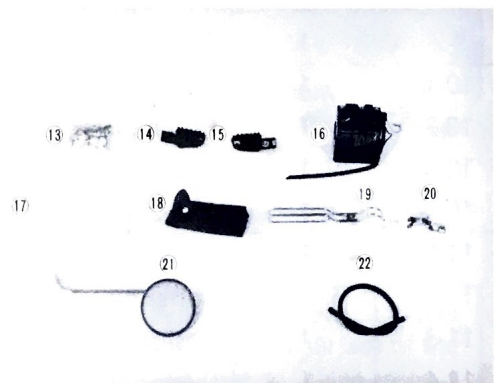
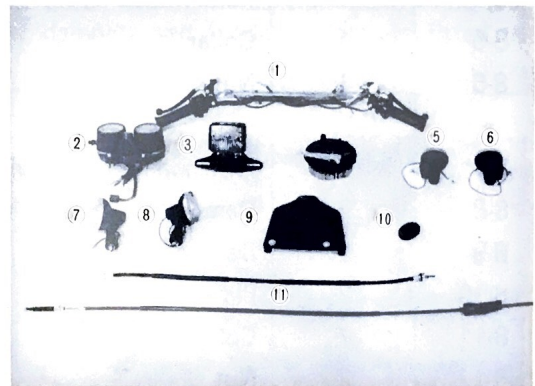
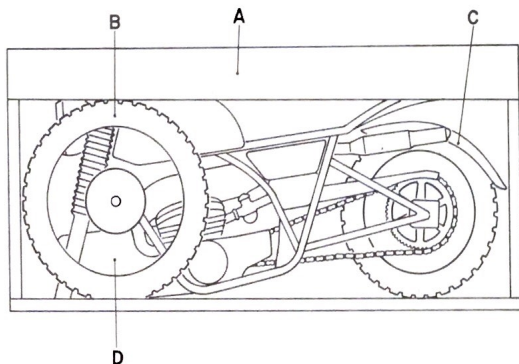

### Details of parts on foam styrol "A"

No.	Q'ty	Parts name
1	1	Handle bar assembly
2	1	Meter panel assembly

Details of parts in vinyl bag

No.	Q'ty	Part name	Remarks
1-1	2	Hexagon head bolt with washer	Double seat
2-1	2	Hexagon head bolt with washer	Rear licence plate
2-2	2	Washer	
2-3	2	Washer	
2-4	2	Nut	
3-1	1	Washer	
3-2	1	Washer	
3-3	1	Nut	
4-1	1	Flasher stay	Front flasher light (R)
4-2	1	Nut	
5-1	1	Flasher stay	Front flasher light (L)
5-2	1	Nut	
6-1	1	Spring washer	Rear flasher light (R)
6-2	1	Nut	
7-1	1	Spring washer	Rear flasher light (L)
7-2	1	Nut	
8-1	1	Hexagon head bolt with washer	Taillight Assembly (Front part)
8-2	1	Damper	
8-3	1	Damper	
8-4	1	Plate washer	
8-5	1	Collar	
8-6	1	Nut	
8-7	2	Hexagon head bolt with washer	Taillight assembly (Rear part)
8-8	2	Damper	
8-9	2	Damper	
8-10	2	Plate washer	
8-11	2	Collar	
8-12	2	Nut	
9-1	1	Cotter pin	Front wheel
9-2	1	Collar	
10-1	1	Torsion spring	Right foot rest
10-2	1	Cotter pin	
10-3	1	Washer	
10-4	1	Clevis pin	
11-1	1	Torsion spring	Left foot rest
11-2	1	Cotter pin	
11-3	1	Washer	
11-4	1	Clevis pin	
12-1	2	Hexagon head bolt with washer	Meter panel Assembly
13-1	1	Hexagon head bolt with washer	Wire holder

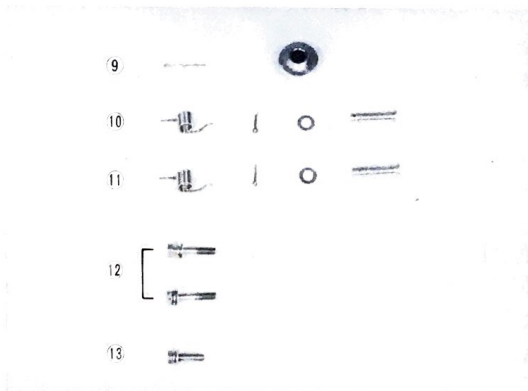
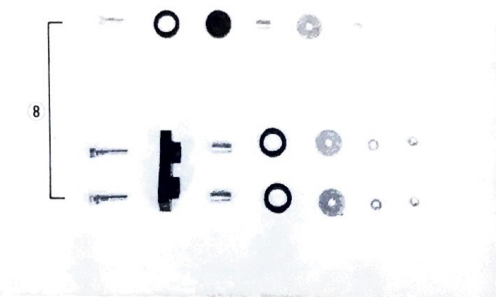
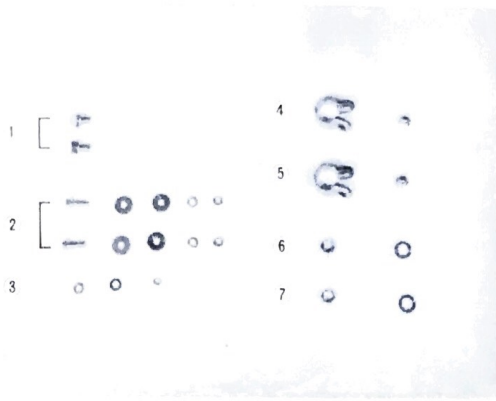

- 1 Bolts: 6 mm x 4 pcs.
- 2 Spring washers: 6 mm x 4 pcs.
- 3 Plain washer : 6.5 mm x 4 pcs.
- 4 Dampers: 8 pcs.
- 5 Fender collars: 4 pcs.

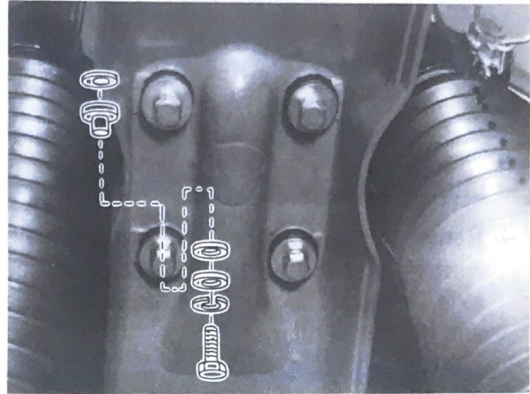

Tightening torque:  
0.45 m-kg (3.25 ft-lb)

- NOTE:**
- a. The front fender should be installed with the arrow mark in the center facing forward.
  - b. Bolts, spring washers, plain washers, dampers and fender collars are fitted to under bracket.

## SET-UP PROCEDURES

1. To install the front fender and front wheel, place a proper-size wooden box or a wooden block under the engine to keep the front of the machine raised off the floor. Take care so that the machine does not fall over.
2. Insert the front fender between the front fork legs, and secure the front fender using the specified number of bolts, spring washers, fender collars, plain washers and dampers.

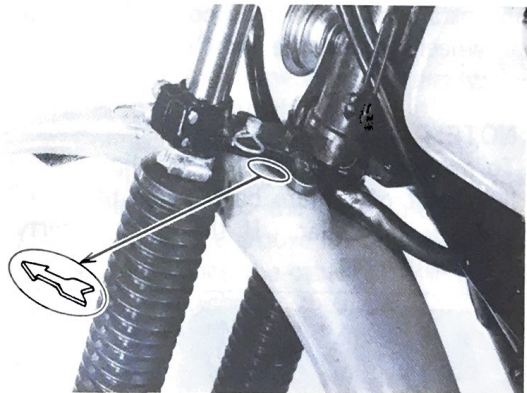

3. Apply a light coat of grease to the speedometer drive gear and oil seal.

**CAUTION:** Take care not to put grease on the brake linings or inner surface of the brake drum. If you do so, clean using a rag dampened with a solvent. Foreign material on braking surface can cause impaired braking action.

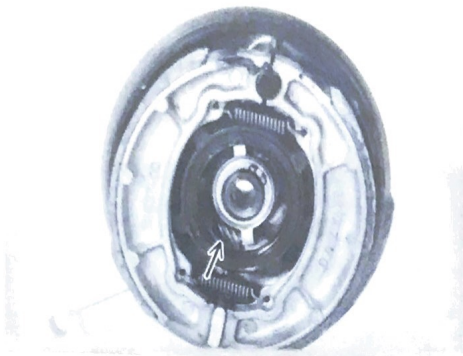

4. Remove the front wheel axle nut and plain washer, and loosen the nuts securing the axle holder. Then remove the wheel axle and distance collar.

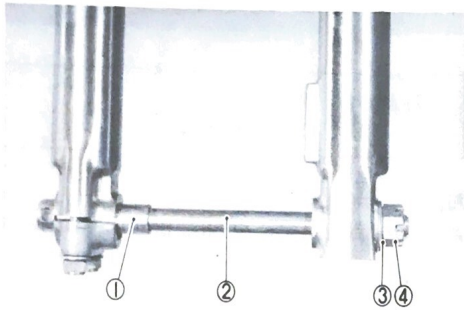

- |                    |                 |
|--------------------|-----------------|
| 1. Distance collar | 3. Plain washer |
| 2. Wheel axle      | 4. Axle nut     |

5. Install the wheel axle collar (9-2) in the wheel hub on the right side of the front wheel.

**NOTE:** \_\_\_\_\_

To avoid damaging the oil seal lip, apply a light coat of lithium base grease to the oil seal lip and collar. If the collar is dirty, clean with a rag.

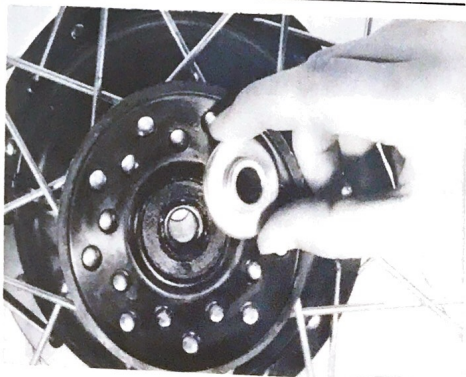

6. Install the brake shoe plate assembly in the front wheel hub.
  - a. Clean the inner surface of the front wheel hub with a clean cloth.

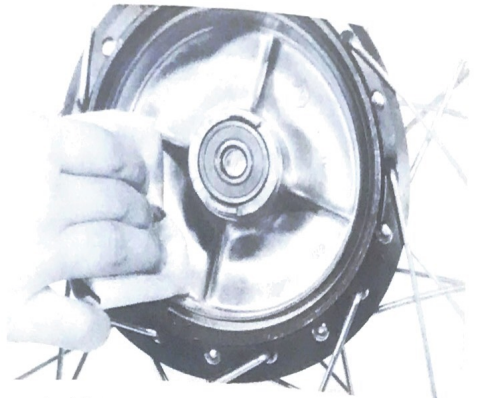

- b. Make sure the brake shoes and springs are correctly installed in the shoe plate assembly. If any one of them is out of plate, correct per the figure.

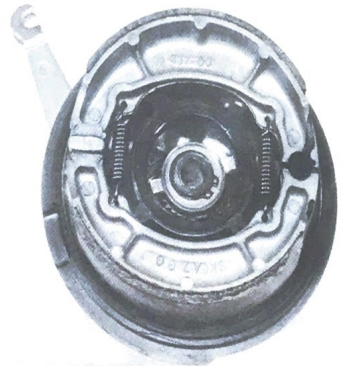

- c. Install the brake shoe plate assembly in the wheel hub.

**NOTE:** \_\_\_\_\_

Make sure the two legs in the wheel hub align with the two slots in the speedometer clutch assembly.

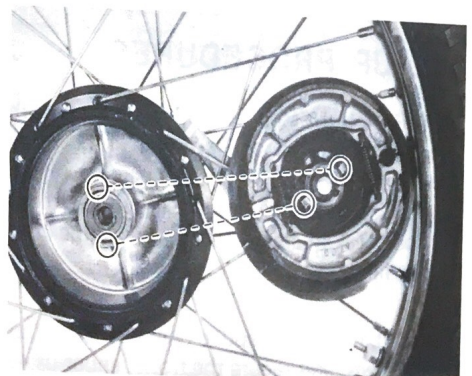

7. Install the front wheel on the front forks.
  - a. Insert the front wheel between the front fork legs so that the stopper (projection) on the front fork end is correctly engaged the slot in the brake shoe plate.



- b. Install the distance collar on the wheel axle. Then, insert the axle, mount the plain washer on the axle, and install the axle nut.
- c. Lightly tighten the axle holder nuts so that the axle does not turn while the axle nut is tightened.
- d. Torque the axle nut to specification.

Tightening torque:  
6.0 m·kg (43ft·lb)

- e. Lock the nut with the cotter pin. (9-1). The pin should be inserted downward, and the pin ends should be bent.

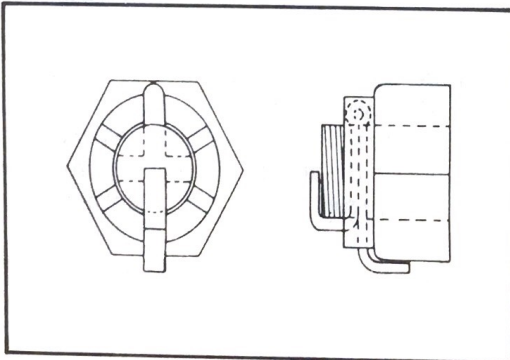

- f. Torque the axle holder nuts to specification.

Tightening torque:  
2.2 m·kg (16ft·lb)

**CAUTION:** Fit the axle holder so the clearance can be provided at the rear. And tight the holder nuts, first the front side and then rear side.

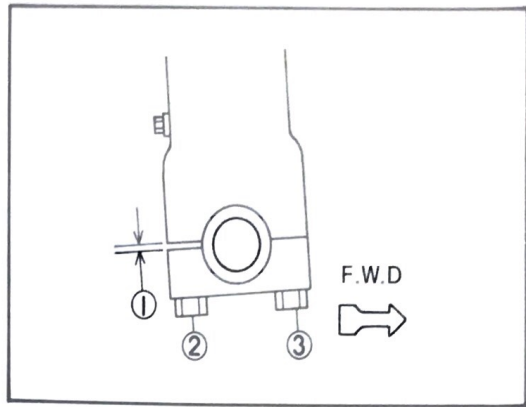

1. Gap 2. 2nd 3. 1st

8. Install the wire holder to the left side projection part of front fork outer tube using damper and bolt with plain and spring washer.

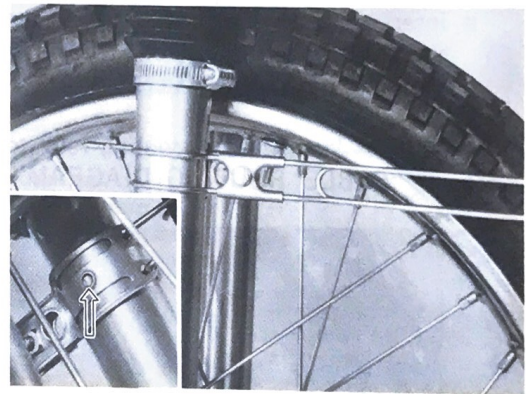

9. Install the speedometer and front brake cables to the front wheel hub.
  - a. Connect the speedometer cable to the front wheel hub gear unit. Insert the cable end into the gear unit, fit the circlip in the groove on the wheel hub side, and lock the cable. (The circlip is already attached to the cable.)

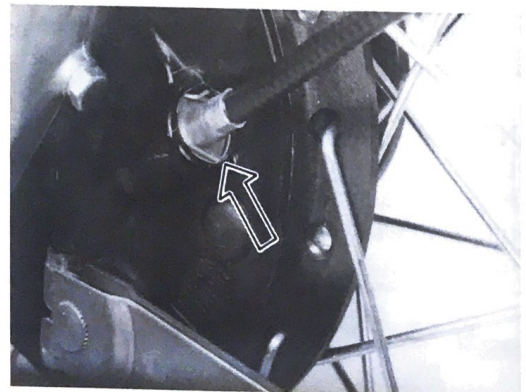

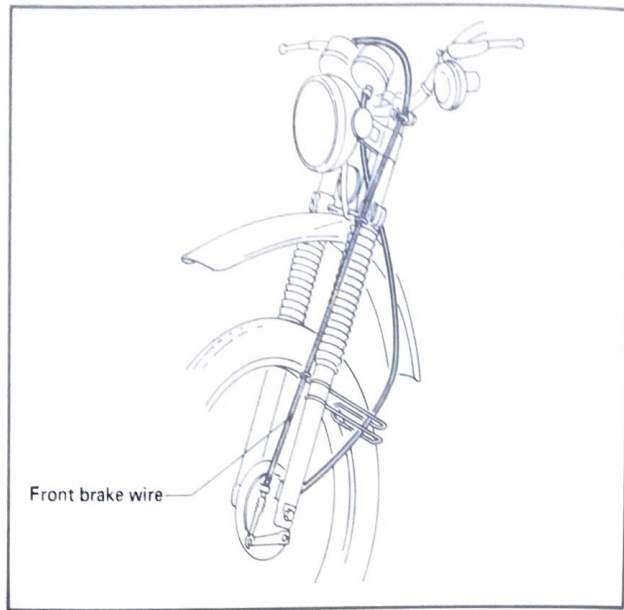

- b. Insert the front brake wire end to the camshaft lever and hook the outer cable end onto the adjuster.

\* For detailed cable routing refer to "CABLE ROUTING DIAGRAM"

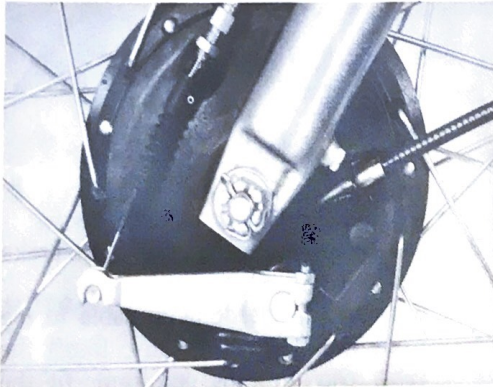

10. Remove the bolt from the bottom of the headlight body. Insert a slotted head screw driver between the headlight body and the headlight Ass'y pry out the lens assembly.

**NOTE:**

During the operation, care should be taken not to scratch the headlight body and lens rim. Also take care so that the anchor screw is not lost.

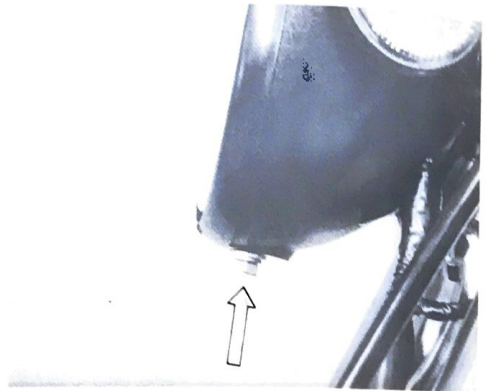

**11. Handlebar installation**

- a. Remove the four hexagon bolts, and remove the two handlebar holders.
- b. Insert the all lead wire coming from the handle switches into the headlight body.
- c. Install the handlebar using the two removed upper holders, four spring washers and hexagon bolts.

Tightening torque:  
1.0 m·kg (7.23ft·lb)

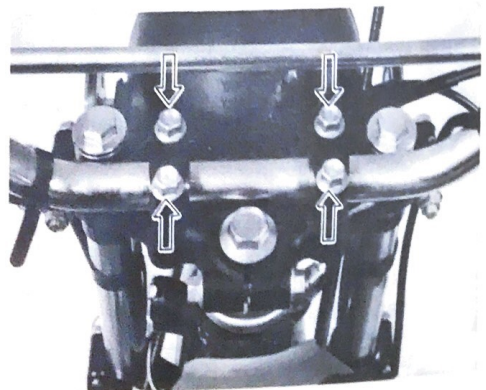



**CAUTION:** First tighten the bolts on the front side of the handlebar holder and tighten the bolts on the rear side.

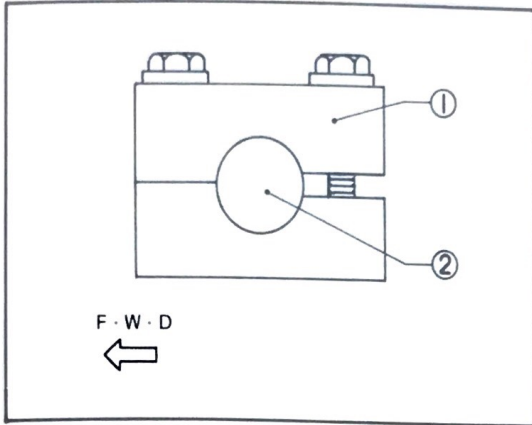

- 1. Holder
- 2. Handlebar

12. Grease the right end of handlebar and the throttle grip housing, and install the throttle grip.

**CAUTION:** Make certain throttle grip rotates on handlebar freely without binding. If not, normal throttle return will be impaired.

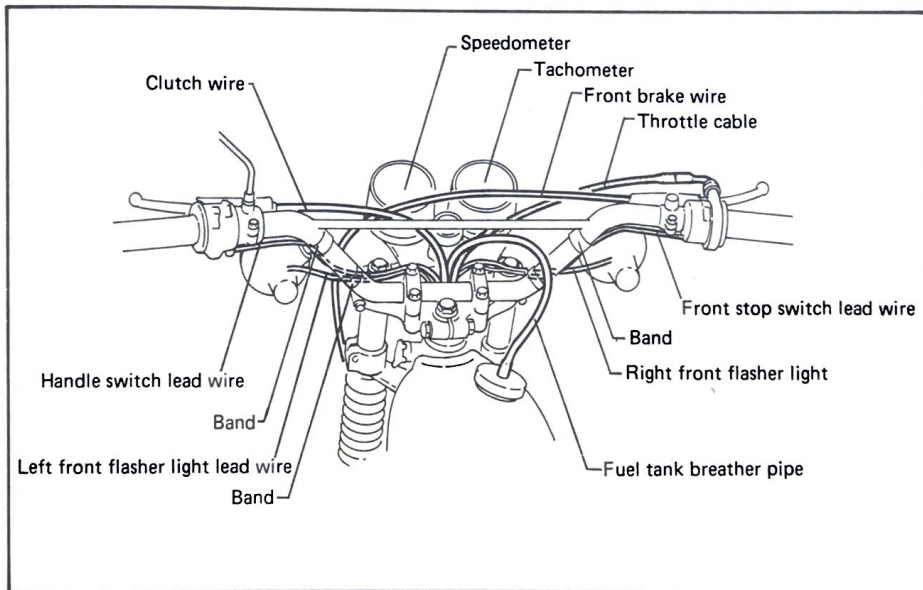
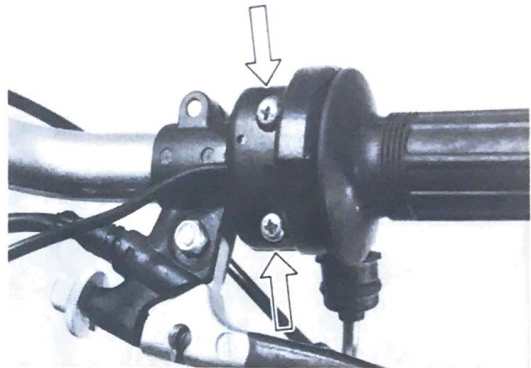

13. Using the bolts with plain and spring washer (12-1) in the vinyl bag install the meter bracket assembly on the handle crown.

**NOTE:** Before securing the meter bracket, all wires should be threaded through the headlight body. Take care not to kink wires by pressure.

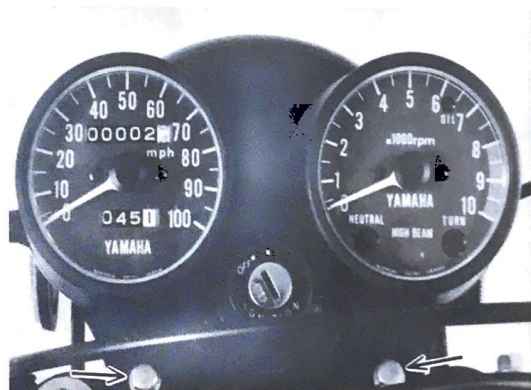

14. Connect the speedometer cable and tachometer cable to the speedometer and tachometer.

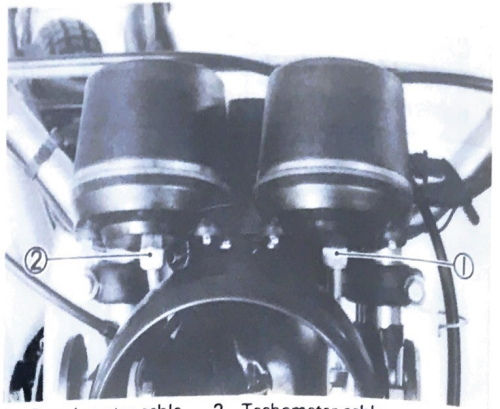

1. Speedometer cable 2. Tachometer cable

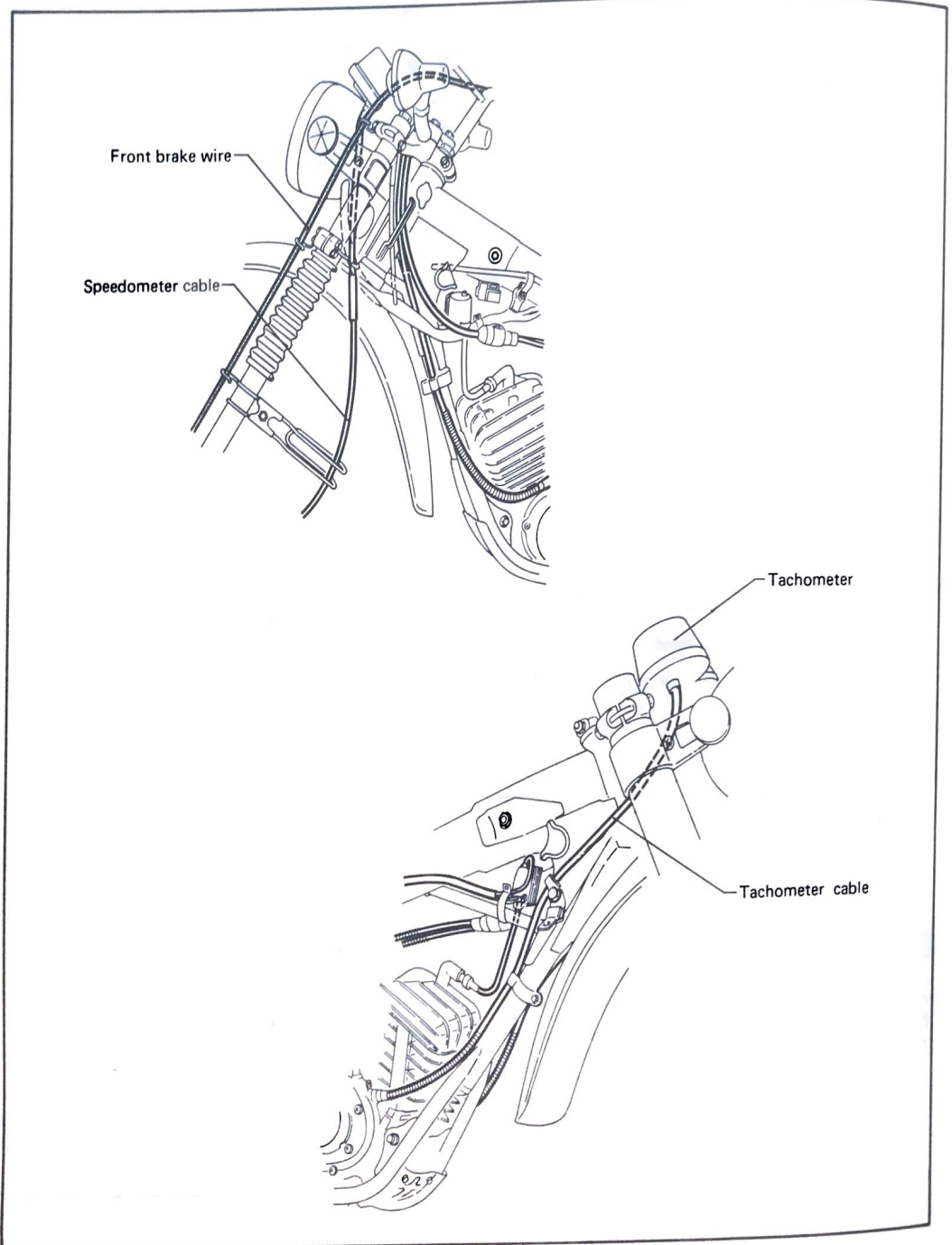

15. Brake wire and clutch wire installation.
  - a. Screw in the cable length adjuster on the front brake shoe plate.
  - b. Fully loosen the lever adjuster locknut, and screw in the adjuster until tight. Next, align the slit in the adjuster and adjuster lock nut with the slit in the lever holder.

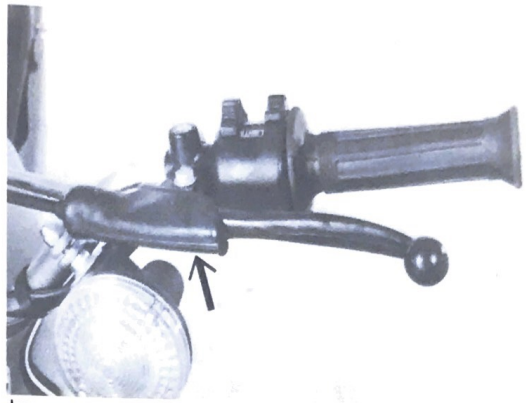
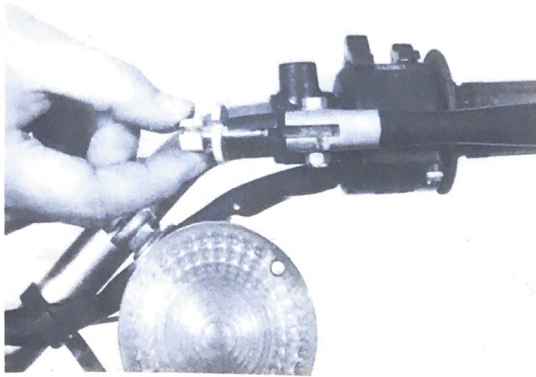

Lever cover

16. Front flasher light installation
  - a. Install the nuts (4-2, 5-2) on the flasher lights.

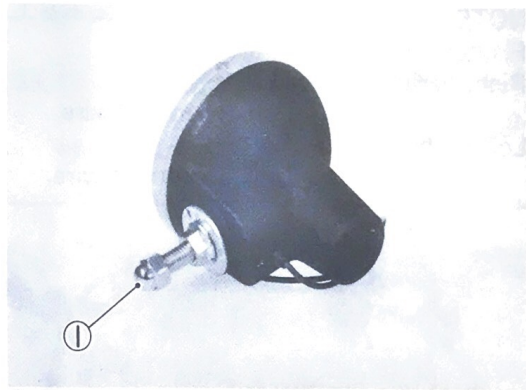

1. Nut

- c. Insert the wire end into the lever hole, and hook the outer cable end onto the adjuster lock nut, then squeeze the lever. Next, while pulling the outer cable in the direction opposite to the lever, release the lever quickly. While releasing it, seat the outer cable into the adjuster.

**CAUTION: Proper cable and wire routing is essential to insure safe vehicle operation. For details of the cable routing, refer to "CABLE ROUTING DIAGRAM".**

- b. Install both right and left front flasher lights to flasher stays of handlebar.
    - c. Lock the nuts.

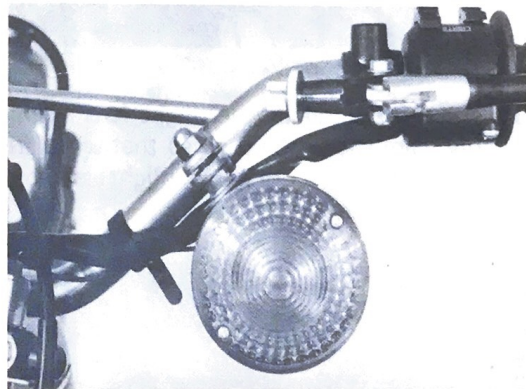
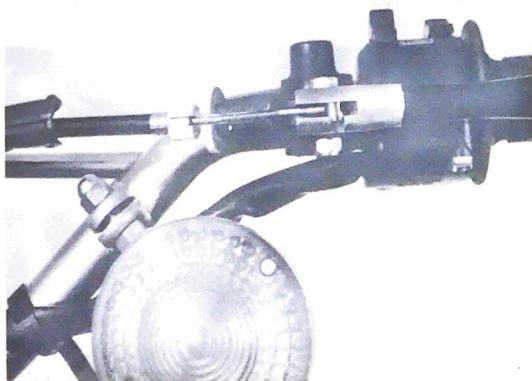

- d. Install the lever covers on clutch and brake wires.

- d. Hold the light lead wire to the handlebar with a rubber band, and insert the lead wire end into the headlight body.

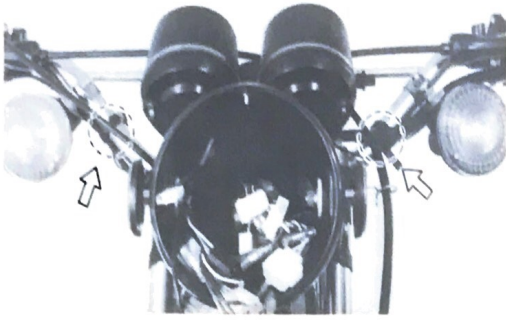

17. Connect all lead wires inside the headlight body. The wires of identical colors should be connected.

**NOTE:** \_\_\_\_\_

Flasher light lead wires are excluded.

Right flasher light lead wire

⇨ Dark green lead wire

Left flasher light lead wire

⇨ Dark brown lead wire

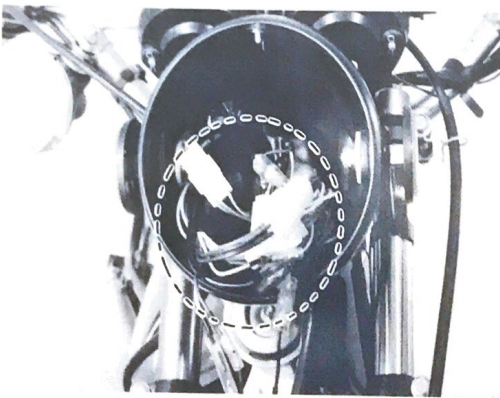

18. When installing the headlight lens assembly, care should be used so that wires are not pinched. Secure the headlight assembly in place with the bolt.

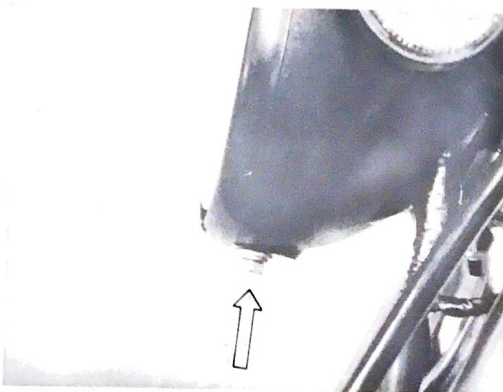

19. Install the rear view mirror on the clutch lever holder (lefthand side), and tighten the lock nut.

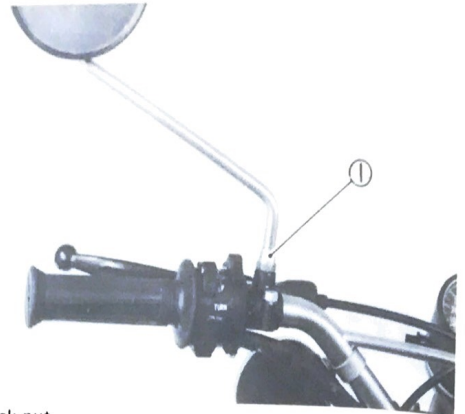

1. Lock nut

20. Fuel tank breather pipe installation

Pass through between the handle crown and meter bracket and let it hang down.

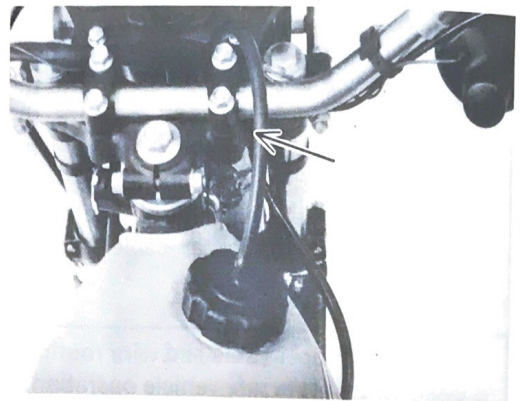

21. Footrest installation

Install the footrest to both right and left sides of the lower part of the frame.

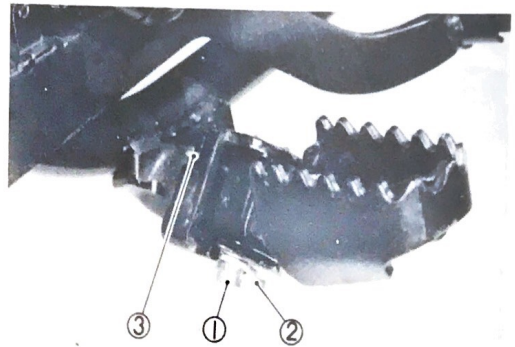

1. Clevis pin    2. Cotter pin    3. Torsion spring

22. Taillight assembly installation

- a. Install the rubber dampers (contained in the vinyl bag) on the taillight bracket.

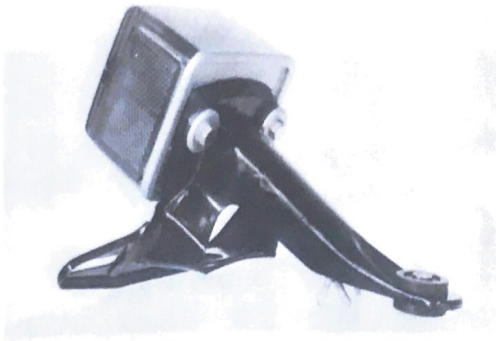

- b. Connect the taillight assembly lead wire to the wire harness, and lock it with the hook. (The wires of identical color should be connected.)

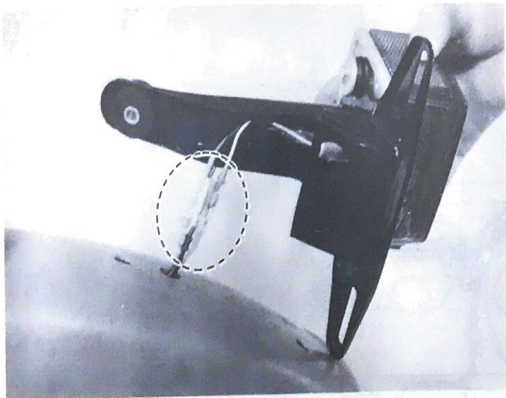

- c. Using the plate washer (8-4), fender mount collar (8-5), bolt (8-1), damper (8-2, 8-3), and crown nut (8-6) contained in the vinyl bag secure the front part of the taillight bracket to the rear fender.

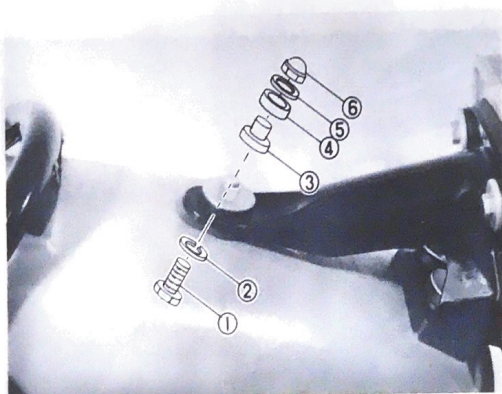

1. Bolt  
2. Spring washer  
3. Damper  
4. Damper  
5. Plate washer  
6. Crown nut

- d. Using the plate washer (8-10), nut (8-12) and bolt (8-7) contained in the vinyl bag secure the rear part of the taillight bracket to the fender.

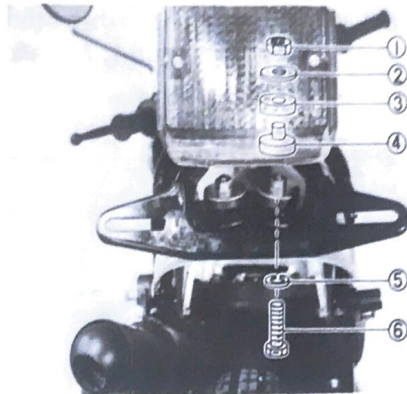

1. Nut  
2. Plate washer  
3. Damper  
4. Damper  
5. Spring washer  
6. Bolt

23. Licence plate installation

Install the license plate to the taillight assembly as shown in the photo.

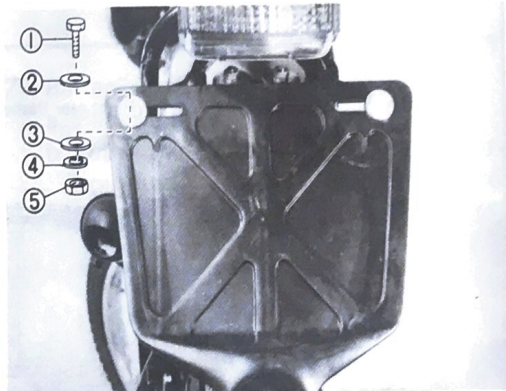

1. Bolt  
2. Plate washer  
3. Plate washer  
4. Spring washer  
5. Nut

24. Rear reflector installation

Install the rear reflector to the license rear plate.

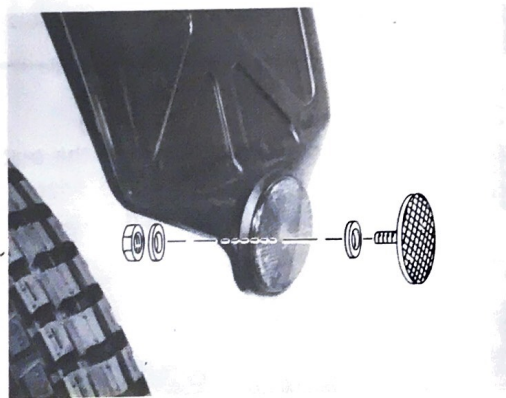

25. Rear flasher light installation

- a. Install the lead wire, with dark brown on the left side. Next, install the other flasher light (dark green lead wire) on the right side.
- b. Install the left and right flasher lights using the spring washer (6-1, 7-1) and nut (6-2, 7-2).

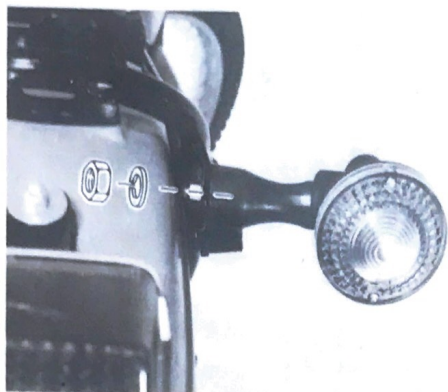

26. Connect the right flasher light lead wire to green lead wire, and left flasher light lead wire to brown lead wire.

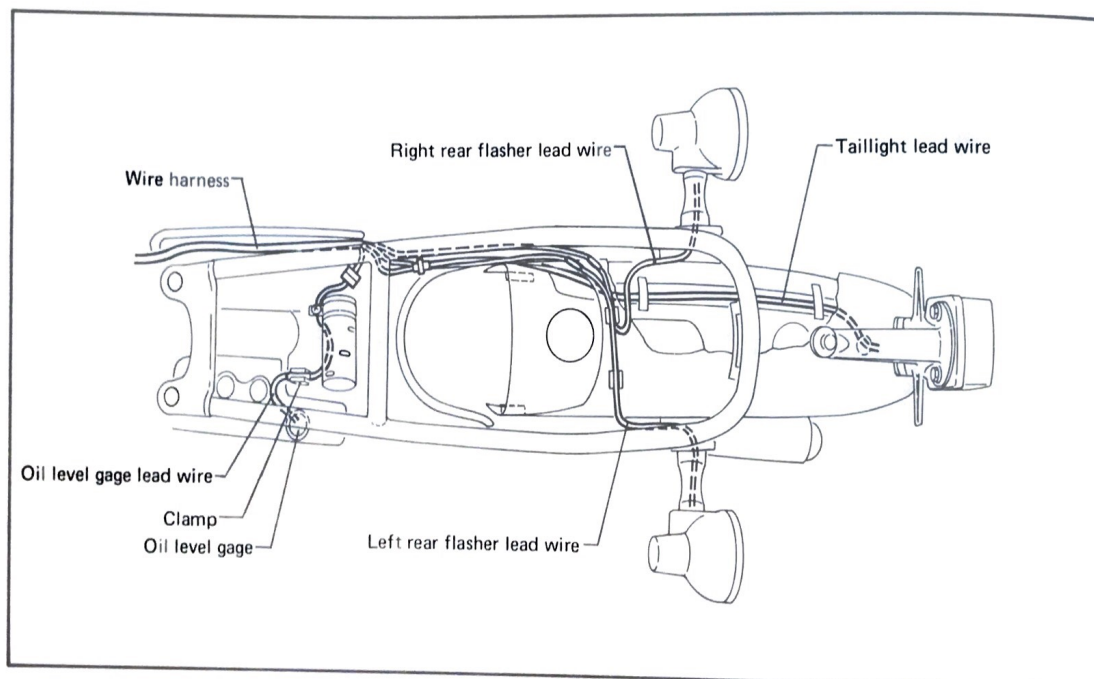

27. Seat installation

Insert the hook on the end of the seat into the frame, and secure both sides of the seat with plain washers and bolts.

Tightening torque:  
1.0 m·kg (7.5 ft·lb)

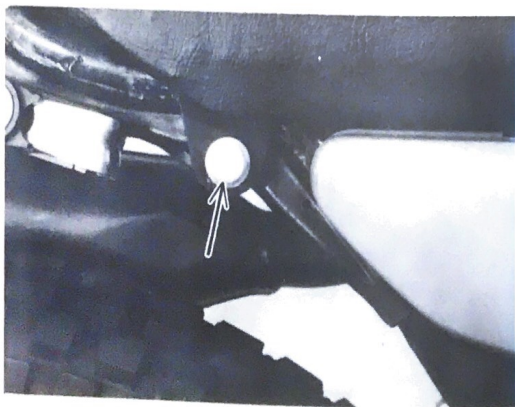

## 28. Battery

- a. Remove the battery from the battery box.

**CAUTION:** Never try to add battery electrolyte (battery acid) to a battery that is installed on a machine. Even skilled mechanic will spill enough acid to damage metal parts. Always remove the battery before filling with electrolyte and during charging. Always completely clean the exterior of the battery before re-installing.

- b. The battery must be charged as much as possible before using for the first time. This initial charge will prolong the life of the battery.

Charging current: 0.6A  
Charging hours: 10 hrs

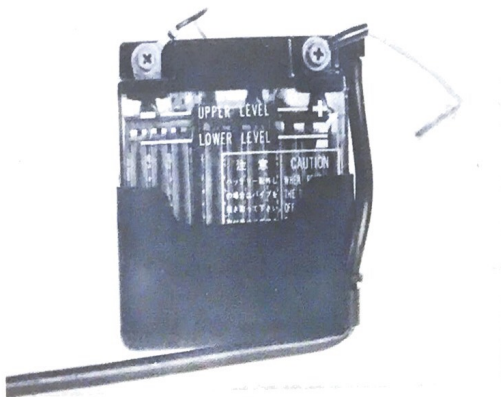

- c. Electrolyte specific gravity

Specific gravity at 20° C  
1.260

- d. Filling the battery with diluted sulfuric acid (electrolyte)

- 1) Remove all filler caps from the battery, and remove the breather pipe cap at the same time.
- 2) Cool the electrolyte down to below 30° C.
- 3) Pour acid into each cell little by little up to the upper level line, and leave it for a while. When the battery fluid permeates the plates and separators, the fluid level begins to lower. Add electrolyte again.

- 4) Charge the battery as required and measure the specific gravity of the fluid. Use a battery hydrometer.
- 5) Install the filler caps, and thoroughly wipe off the fluid around the filler caps. Wipe off the battery completely before installation

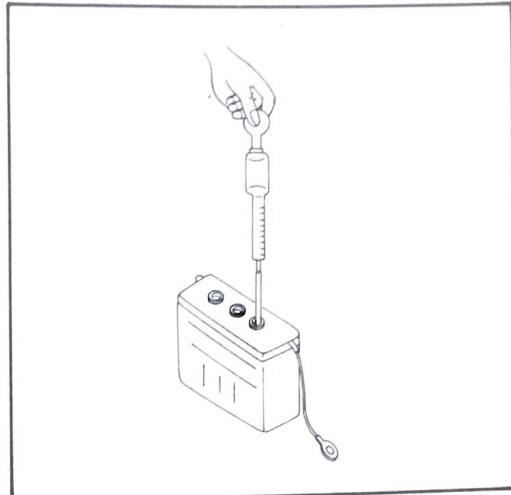

## 29. Battery installation

- a. Remove the right side cover.
- b. Push the battery into the battery box and secure it with the band.

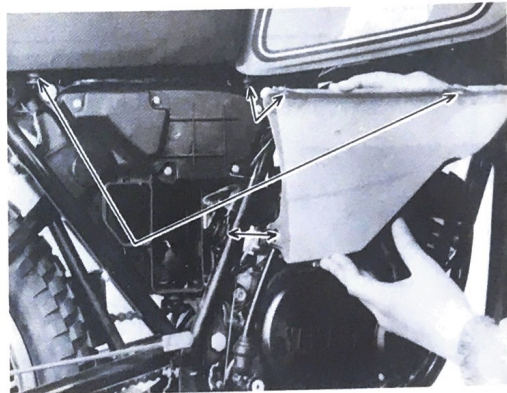

- c. Connect the positive lead wire first, and then connect the negative lead wire.

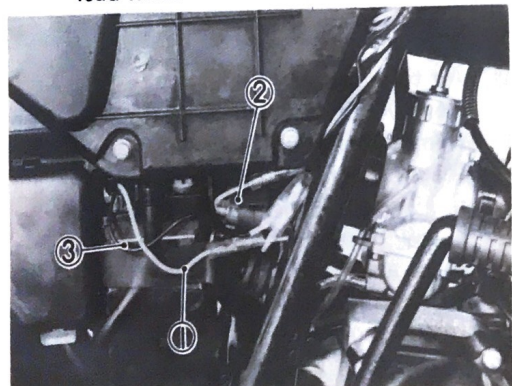

1. Positive lead wire 2. Fuse 3. Negative lead wire

- d. The breather pipe should be passed as illustrated.

**NOTE:**  
Route the breather pipe outlet down and away from any part of the machine.

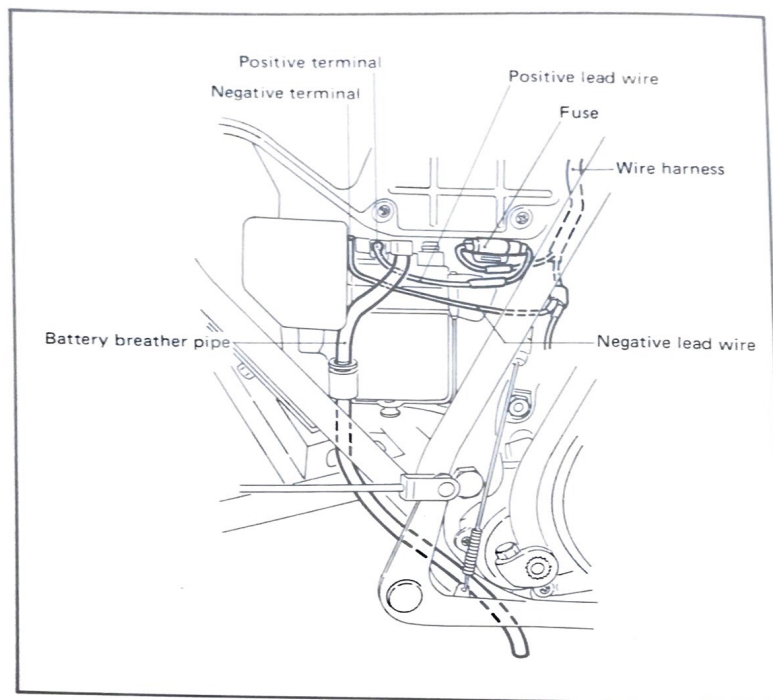

30. Install the service tool assembly as photo.

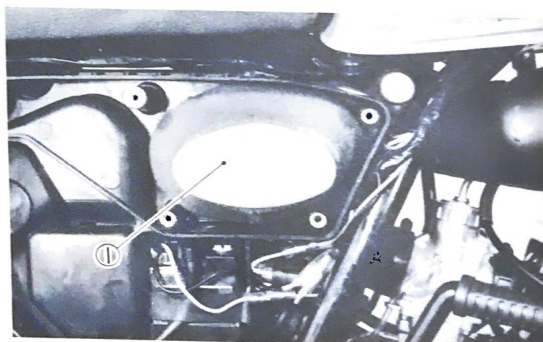
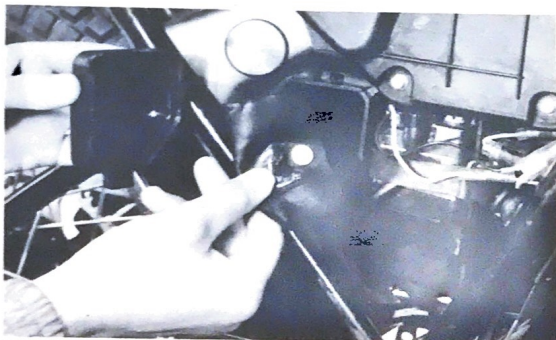

1. Air filter element

31. Air filter preparation

Remove air filter element from the case. Remove foam from wire mesh core. Wash foam clean in solvent. Remove all dirt and oil. Wring out foam until almost dry. Pour a few ounces of 30 wt. motor oil over foam and work it into the entire surface. Wring out gently to remove excess oil (foam should be wet but not dripping).



# INSPECTION AND ADJUSTMENT

## Inspections

After all packed parts are installed check to see that all these parts and other parts (mounted or installed at the Yamaha factory) are correctly mounted or installed, or tighten to specification. This check-up should be started with the front of the machine.

## Item

Front wheel spokes . . . . .	Tension
Front wheel rim . . . . .	Hopping, deflection
Front wheel tire . . . . .	Tire pressure
Front wheel axle nut . . . . .	Cotter pin, tightening torque
Front wheel axle holder lock nuts . . . . .	Tightening torque
Steering head lock nut . . . . .	Tightening torque
Handlebar holder . . . . .	Tightening torque
Clutch lever holder . . . . .	Tightening torque
Brake lever holder . . . . .	Tightening torque
Front flasher light . . . . .	Mounting, wiring
Throttle housing . . . . .	Position, operation, tightness
Engine mounting bolts . . . . .	Tightening torque
Carburetor joint (s) . . . . .	Tightness
Footrests . . . . .	Tightening torque
Change pedal . . . . .	Position, looseness, operation
Brake pedal . . . . .	Position, looseness, operation
Seat . . . . .	Mounting, clevis pin, stoppers
Fuel tank . . . . .	Mounting
Fuel pipe . . . . .	Connection
Battery . . . . .	Mounting, fluid level, wiring
Rear fender . . . . .	Mounting
Taillight . . . . .	Mounting, wiring
Rear flasher light . . . . .	Mounting, wiring
Rear shock absorber . . . . .	Mounting, tightening torque
Rear swing arm pivot shaft . . . . .	Tightening torque
Rear axle nut . . . . .	Cotter pin, tightening torque
Chain puller . . . . .	Lock nut
Rear wheel . . . . .	Spoke tension
Rear wheel rim . . . . .	Hopping, deflection
Rear wheel tire . . . . .	Tire pressure
Transmission oil . . . . .	Oil level
Engine oil . . . . .	Oil level

## Adjustments

### NOTE:

This section deals with the main points only. For details, refer to the service manual for this model.

1. Idling speed adjustment
  - a. Before adjustment, fully warm up the engine.
  - b. Fully tighten the air screw, and turn in and out the throttle stop screw so that the engine runs at the lowest possible speed.
  - c. Slowly back out the air screw, and the engine speed increase. When the engine idles faster, stop turning the air screw.

Standard turns out	
DT125E:	1 - 1/4
DT175E:	1 - 1/2

- d. Next, turn the throttle stop screw so that the engine idles at the specified speed.

Standard speed	
DT125E:	1,450 – 1,550 r.p.m.
DT175E:	1,300 – 1,400 r.p.m.

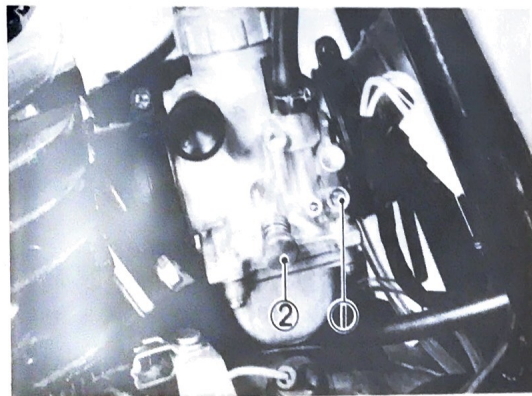

1. Pilot stop screw      2. Throttle stop screw

2. Throttle wire adjustment
  - a. After adjusting the idling speed, adjust the play in throttle wire 2 to 1.0 mm.
  - b. Next, adjust the play to throttle wire 1 to 5 – 8 mm at the throttle grip flange position shown in the figure.

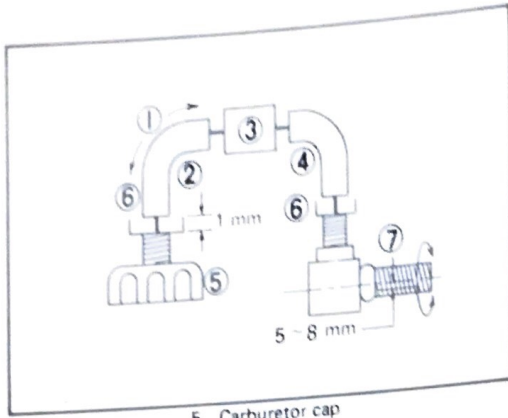

- |                   |                   |
|-------------------|-------------------|
| 1. Slide          | 5. Carburetor cap |
| 2. Wire 2         | 6. Cable adjuster |
| 3. Junction block | 7. Throttle grip  |
| 4. Cable 1        |                   |

### 3. Pump wire adjustment

- Remove pump cover.
- Open throttle slightly to take up all play.
- Loosen wire adjuster lock nut and turn adjuster in or out until the proper mark on the adjusting pulley is aligned with the guide pin.

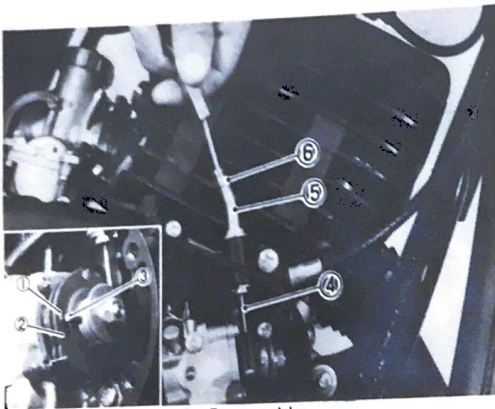

- |                  |                      |
|------------------|----------------------|
| 1. Mark (O)      | 4. Pump cable        |
| 2. Adjust pulley | 5. Adjuster          |
| 3. Pin           | 6. Adjuster lock nut |

### 4. Front brake wire adjustment

Loosen the brake wire adjuster lock nut, and adjust the play of the brake lever (at the position illustrated) to specification. After the adjustment, be sure to screw in the lock nut until tight.

Standard value: 5 - 8 mm

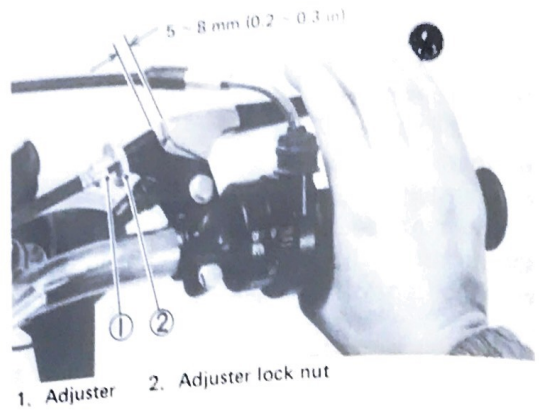

- |             |                      |
|-------------|----------------------|
| 1. Adjuster | 2. Adjuster lock nut |
|-------------|----------------------|

### 5. Clutch wire adjustment

Loosen the clutch wire adjuster lock nut, and adjust the clutch wire by turning the wire adjuster. Turning the adjuster clockwise (the adjuster is tightened) increases clutch wire play, while turning counterclockwise decreases the play. The play should be 2 - 3 mm at the position shown in the figure.

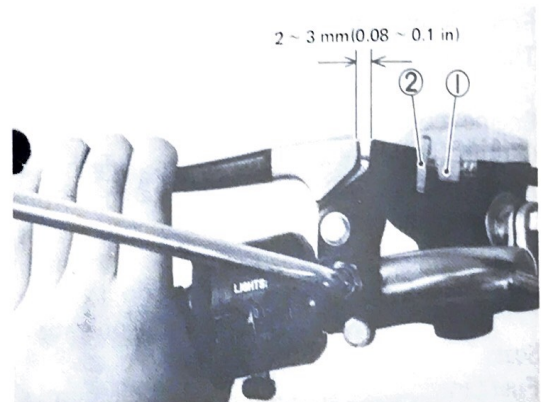

- |             |                      |
|-------------|----------------------|
| 1. Adjuster | 2. Adjuster lock nut |
|-------------|----------------------|

### 6. Rear brake pedal adjustment

Rear brake pedal play can be adjusted by turning the adjusting not on the rear end of the brake rod. Turning clockwise (tightening) decreases play. Turning counterclockwise (loosening) increases play.

Standard value:

20 - 30 mm at the brake pedal

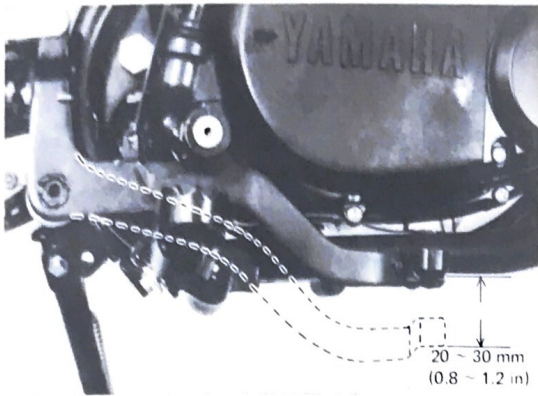

After starting the engine, check the ignition timing, and if necessary, adjust.

Ignition timing:  $1.8 \pm 0.15 \text{ mm}$

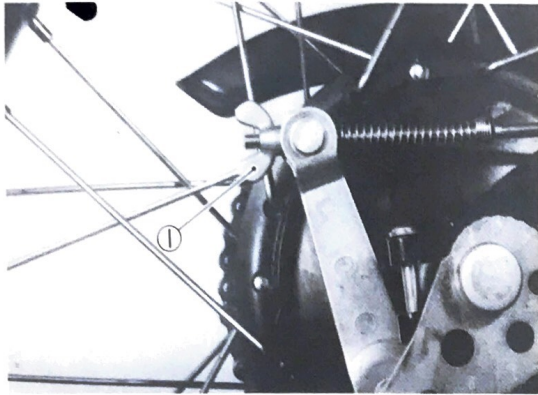
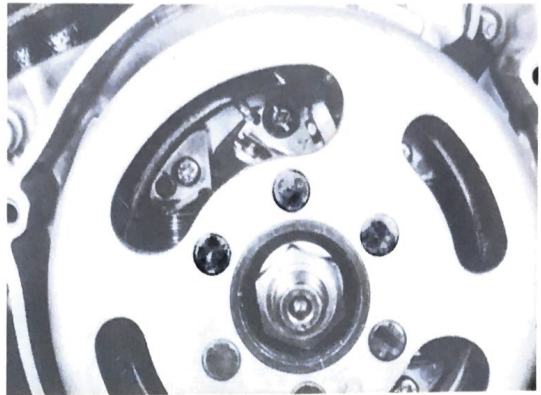

1. Adjusting nut

d. Spark plug – checking and adjustment  
When the machine is stored or not used for a long period of time, the spark plug may get wet with oil. If so, hard starting will result. Remove the spark plug, and clean as required.

7. If the engine will not start or will not start easily after inspection and adjustments are complete, check the following parts.

a. Carburetor

Remove the drain screw attached to the carburetor float bowl, and drain off the gasoline.

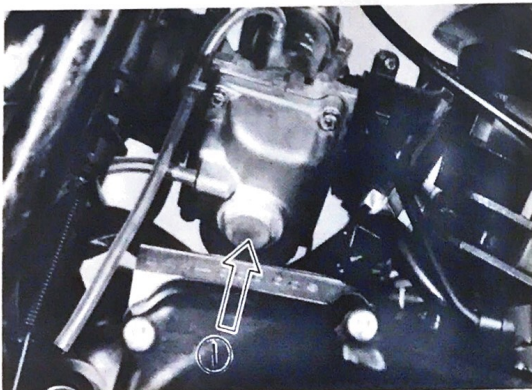
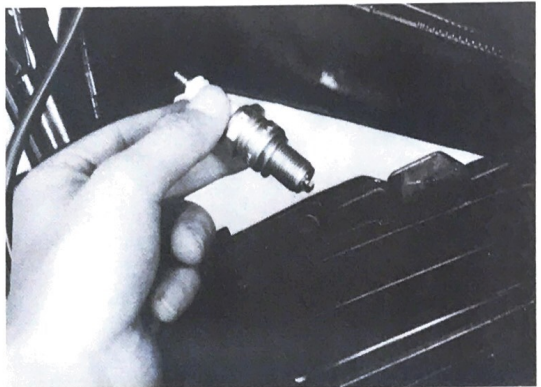

1. Drain screw

- b. Breaker points – checking and cleaning  
If the engine is hard to start, the breaker point surfaces are considered to be dirty. Cleans with a clean cloth damped with a solvent, and try to start the engine.
- c. Ignition timing – checking and adjustment



SINCE 1887

**YAMAHA MOTOR CO.,LTD.**

IWATA, JAPAN

LIT-11666-00-70

PRINTED IN JAPAN  
77-3-2.05x1 ㊞