

YAMAHA

PARTS CATALOGUE

YZ80J (5X2)

125X2-300E1

FOREWORD

This Parts Catalogue is related to the parts in use for the Yamaha YZ 80J (5X2).

When you are ordering replacement parts for the YZ 80J (5X2), refer to this Parts Catalogue and quote both part numbers and part names correctly.

1. Modifications or additions which have been made after issue of the Parts Catalogue will be announced in the Yamaha Parts News.
It is advisable that according to the Yamaha Parts News you make necessary corrections to the Parts Catalogue on hand to keep it up-to-date.

2. Abbreviations

The following abbreviations are used in this Parts Catalogue.

- U.R. Use size (thickness) and/or number as required.
- U.N. Use as many as you need.
- A.P. Alternate Parts
- L.M. Local Made
- F# Frame No. (Applicable machine No.)

3. The parts marked with (+) in the parts number column of this Catalogue are not supplied with by Yamaha, those have to be found locally.
4. Parts, which are to be supplied in the form of assemblies, are listed with an indention of one letter's space, and a dot (.) is put against the name of each part.

EXAMPLE CARBURETOR ASS'Y
 . JET, pilot
 . NOZZLE, main

5. Indication of No. of constituent parts for assembly

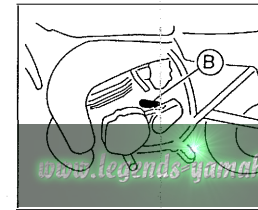
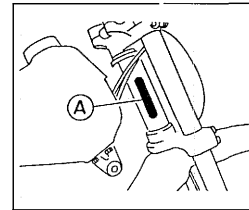
The numeral appearing to the right of each constituent part under the description indicates the quantity of such parts for each individual assembly unit.

EXAMPLE

Part No.	Description	Q'ty	Remarks
2F5-83310-60	FRONT FLASHER LIGHT ASS'Y	2	
115-83311-60	. BULB (6V-18W)	1	
1M1-83309-60	. REFLECTOR	1	

6. Initial Serial No. and Color Code

(A) Frame Serial No.	5X2-000101 and following
(B) Engine Serial No.	5X2-000101 and following



Color Code	Color Name	Abbreviate
36	Clean White	W

7. Applicable colors of graphics are represented in the "Remarks" column by the letter(s) appropriately picked out of the full word(s) showing such colors.

EXAMPLE

Part No.	Description	Q'ty	Remarks
2N4-24110-00-X5	FUEL TANK COMP.	1	MAXIM RED
3J1-24240-10	. GRAPHIC, fuel tank set	1	for MXR

CONTENTS

ENGINE

Fig. 1	Cylinder Head · Cylinder	1
Fig. 2	Crankshaft · Piston	2
Fig. 3	C.D.I. Magneto	3
Fig. 4	Water Pump	4
Fig. 5	Radiator Hose	5
Fig. 6	Intake	6
Fig. 7	Carburetor	7
Fig. 8	Exhaust	9
Fig. 9	Crankcase	10
Fig. 10	Crankcase Cover	11
Fig. 11	Kick Starter	12
Fig. 12	Clutch	13
Fig. 13	Transmission	14
Fig. 14	Shift Cam · Fork	15
Fig. 15	Shift Shaft · Pedal	16

CHASSIS

Fig. 16	Frame · Tool	17
Fig. 17	Front Fender · Rear Fender	18
Fig. 18	Side Cover	19
Fig. 19	Rear Arm	20
Fig. 20	Rear Suspension	21
Fig. 21	Steering	23
Fig. 22	Front Fork	25
Fig. 23	Fuel Tank	26
Fig. 24	Seat	28
Fig. 25	Front Wheel	29
Fig. 26	Rear Wheel	30
Fig. 27	Handlebar · Cable	32
Fig. 28	Stand · Footrest	33
Fig. 29	Electrical 1	35
Fig. 30	Handle Switch · Lever	36

EXCLUSIVE FOR AUSTRALIA, N.S.W.

Fig. 31	Alternate (Engine)	37
---------	--------------------------	----

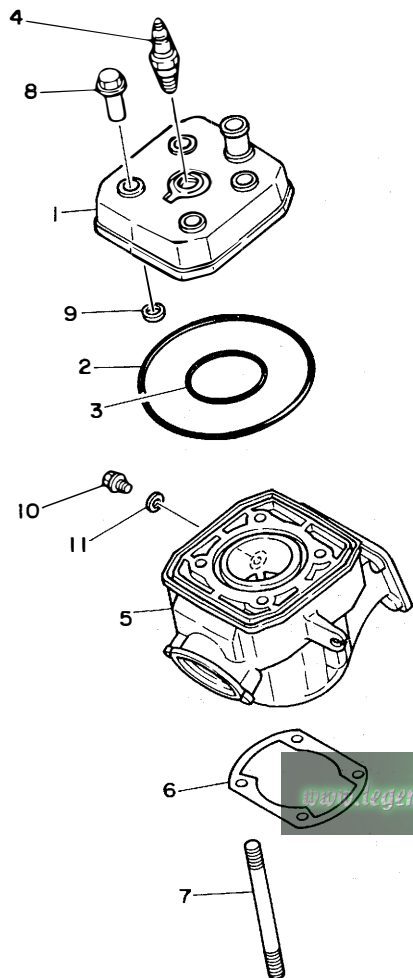
REPAIR KIT

Fig. 32	Repair Kit	38
---------	------------------	----

INDEX

Numerical Index
Parts Name Index

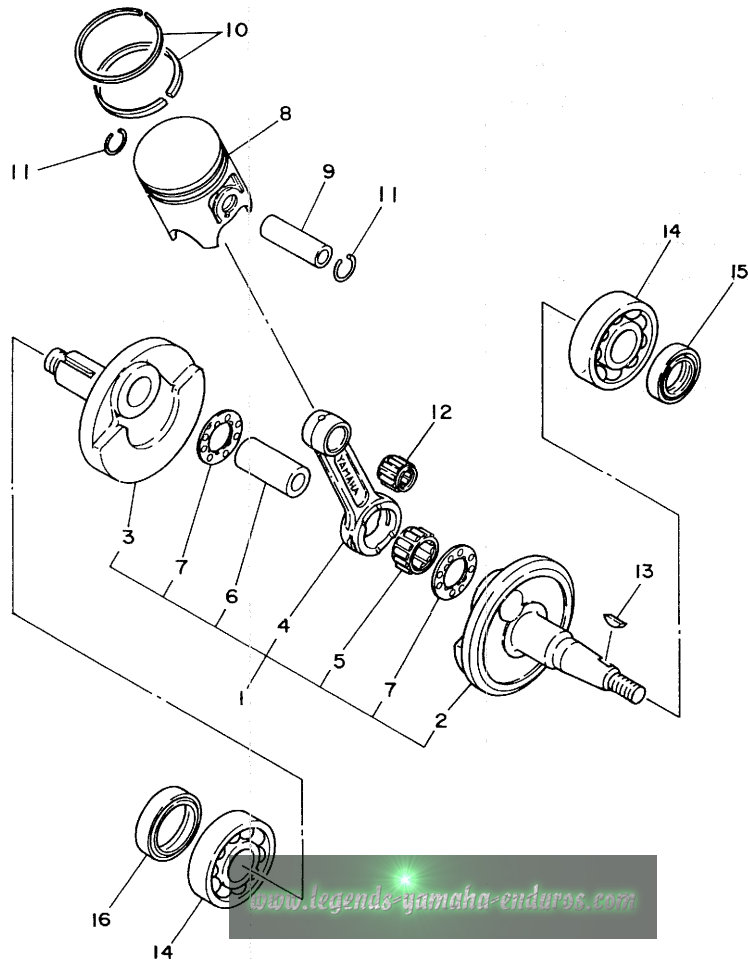
FIG. 1 CYLINDER HEAD. CYLINDER



REF. NO.	PART NO.	DESCRIPTION	Q'TY	REMARKS
1	5X2-11111-00	HEAD, cylinder 1	1	
2	93211-13109	O-RING	1	
3	93210-60538	O-RING	1	
4	* 6723	PLUG, sPark	1	LM
5	5X2-11311-00	CYLINDER 1	1	
6	4V0-11351-00	GASKET, cylinder	1	
7	90116-08368	BOLT, stud	4	
8	90179-08358	NUT	4	
9	90430-12174	GASKET	4	
10	95826-06010	BOLT, flange	1	
11	90430-06166	GASKET	1	



FIG. 2 CRANKSHAFT·PISTON

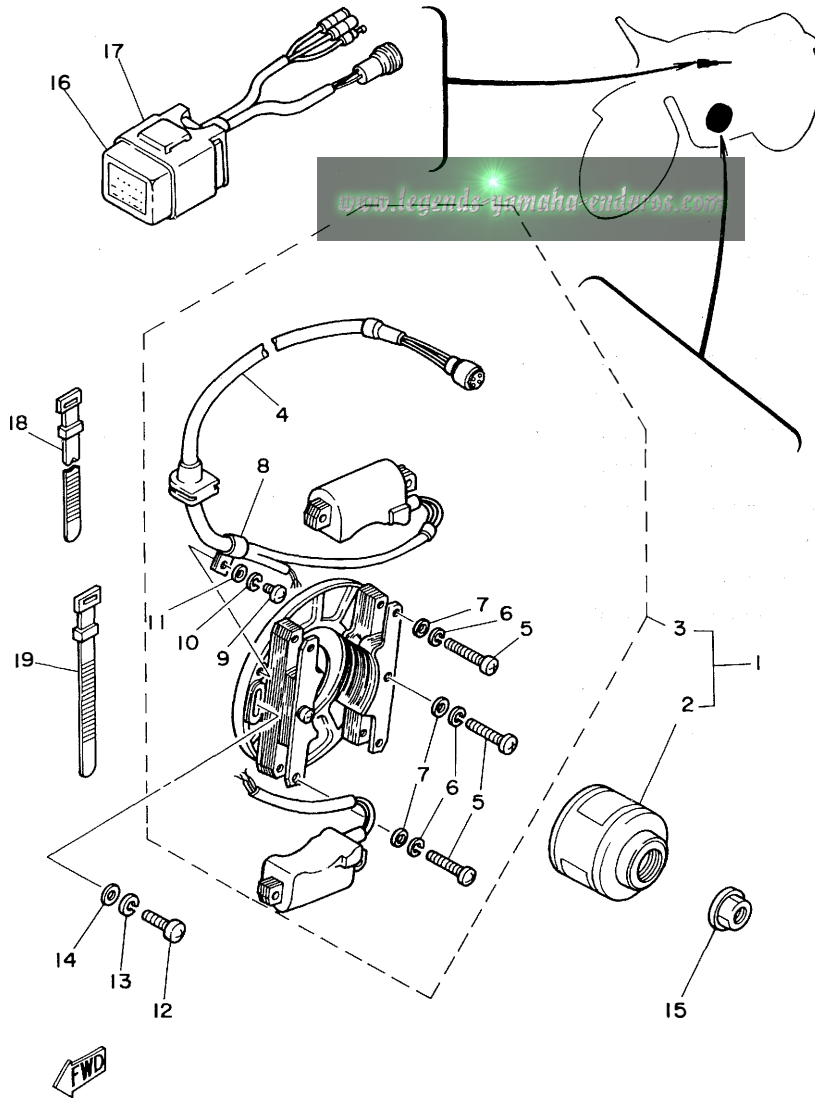


REF. NO.	PART NO.	DESCRIPTION	Q'TY	REMARKS
1	5X2-11400-00	CRANKSHAFT ASSY	1	
2	5X2-11412-00	•CRANK 1	1	
3	5X2-11422-00	•CRANK 2	1	
4	5X2-11651-00	•ROD, connecting	1	
5	93310-418U1	•BEARING, cylindrical	1	
6	4V0-11681-00	•PIN, crank 1	1	
7	90209-18112	•WASHER	2	
8	5X2-11631-00-94	PISTON (STD)	1	UR
	5X2-11631-00-95	PISTON (STD)	1	UR
	5X2-11635-00	PISTON (1ST O/S 0.25MM)	1	AP
	5X2-11636-00	PISTON (2ND O/S 0.50MM)	1	AP
	5X2-11637-00	PISTON (3RD O/S 0.75MM)	1	AP
	5X2-11638-00	PISTON (4TH O/S 1.00MM)	1	AP
9	4V1-11633-00	PIN, Piston	1	
10	5X2-11601-00	PISTON RING SET (STD)	1	
	5X2-11601-10	PISTON RING SET (1ST O/S)	1	AP
	5X2-11601-20	PISTON RING SET (2ND O/S)	1	AP
	5X2-11601-30	PISTON RING SET (3RD O/S)	1	AP
	5X2-11601-40	PISTON RING SET (4TH O/S)	1	AP
11	5X2-11634-00	CLIP, Piston Pin	2	
12	93310-212H4	BEARING, cylindrical	1	
13	90280-03017	KEY, woodruff	1	
14	93306-20438	BEARING	2	
15	93102-20231	OIL SEAL	1	
16	93103-28126	OIL SEAL	1	



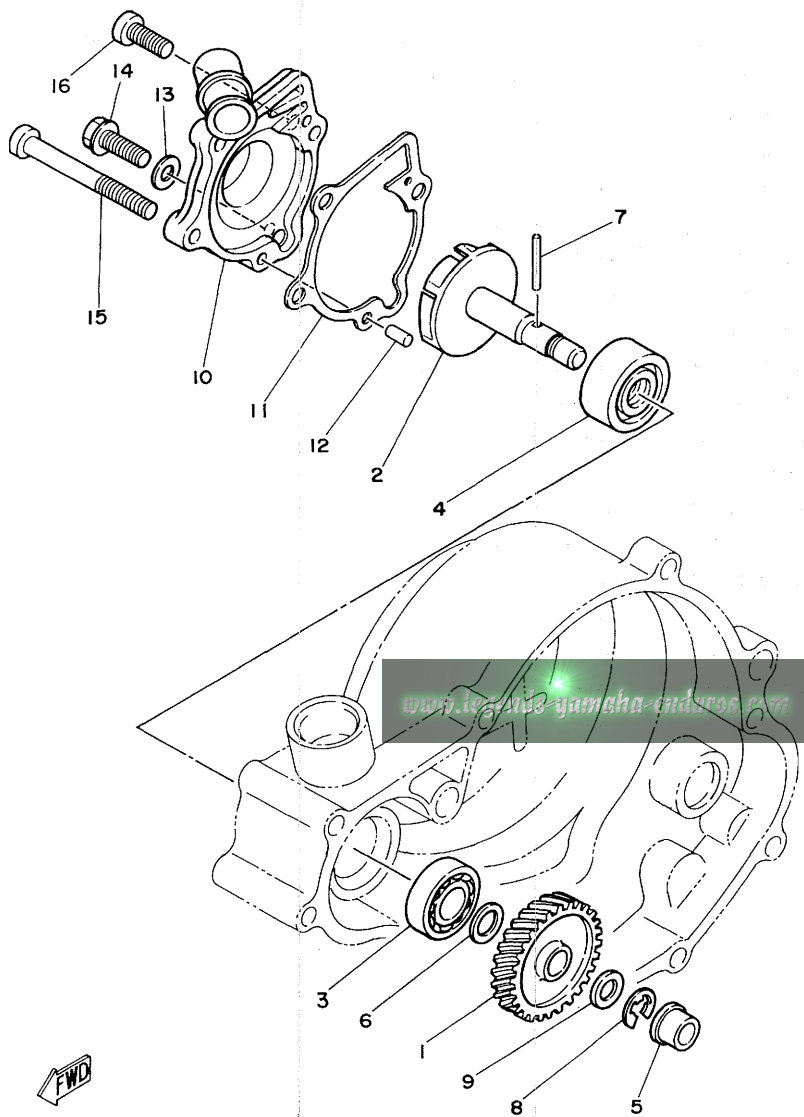
B3

FIG. 3 C.D.I MAGNETO



REF. NO.	PART NO.	DESCRIPTION	Q'TY	REMARKS
1	5X2-85500-10	C.D.I. MAGNETO ASSY	1	
2	5X2-85550-10	•ROTOR ASSY	1	
3	5X2-85510-10	•STATOR ASSY	1	
4	5X2-85520-10	•COIL, charge	1	
5	98501-05030	•SCREW, Pan head	6	
6	92901-05100	•WASHER, sPring	6	
7	92901-05600	•WASHER, Plate	6	
8	109-81328-11	•CLAMP	1	
9	98501-04008	•SCREW, Pan head	1	
10	92901-04100	•WASHER, sPring	1	
11	92901-04600	•WASHER, Plate	1	
12	92501-06020	SCREW, Pan head	2	
13	92901-06100	WASHER, sPring	2	
14	92901-06600	WASHER, Plate	2	
15	90179-10257	NUT	1	
16	5X2-85540-10	C.D.I. UNIT ASSY	1	
17	3R1-85546-00	BAND	1	
18	437-83936-10	BAND, switch cord	1	
19	437-83936-00	BAND, switch cord	1	

FIG. 4 WATER PUMP

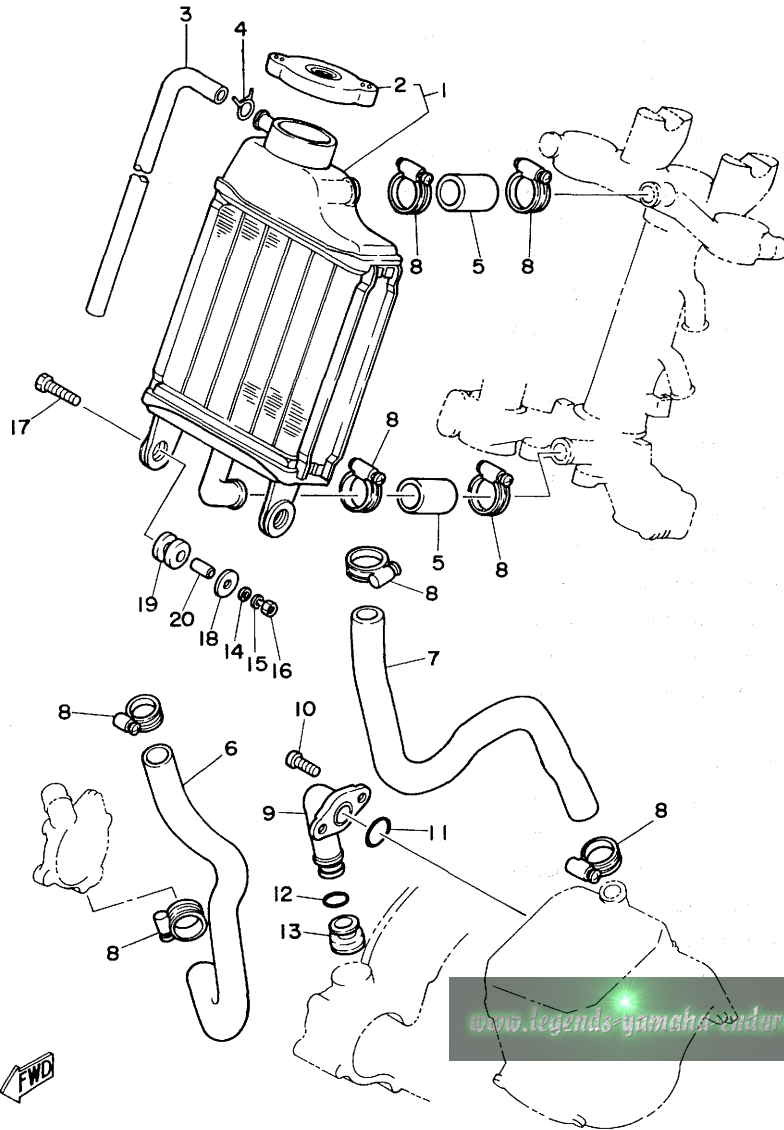


REF. NO.	PART NO.	DESCRIPTION	Q'TY	REMARKS
1	5X2-12459-01	GEAR, imPeller shaft	1	
2	5X2-12450-01	IMPELLER SHAFT ASSY	1	
3	93306-00105	BEARING (B6001)	1	
4	93103-12119	OIL SEAL	1	
5	90381-08002	BUSH, solid	1	
6	90201-10614	WASHER, Plate	1	
7	93603-22028	PIN, dowel	1	
8	93430-07012	CIRCLIP	1	
9	90201-08085	WASHER, Plate	1	
10	5X2-12422-00	COVER, housing	1	
11	5X2-12428-00	GASKET, housing cover 2	1	
12	93604-10011	PIN, dowel	2	
13	90430-06166	GASKET	1	
14	95826-06020	BOLT, flange	1	
15	92506-06060	SCREW, Pan head	2	
16	92506-06016	SCREW, Pan head	1	

FWD

B5

FIG. 5 RADIATOR.HOSE



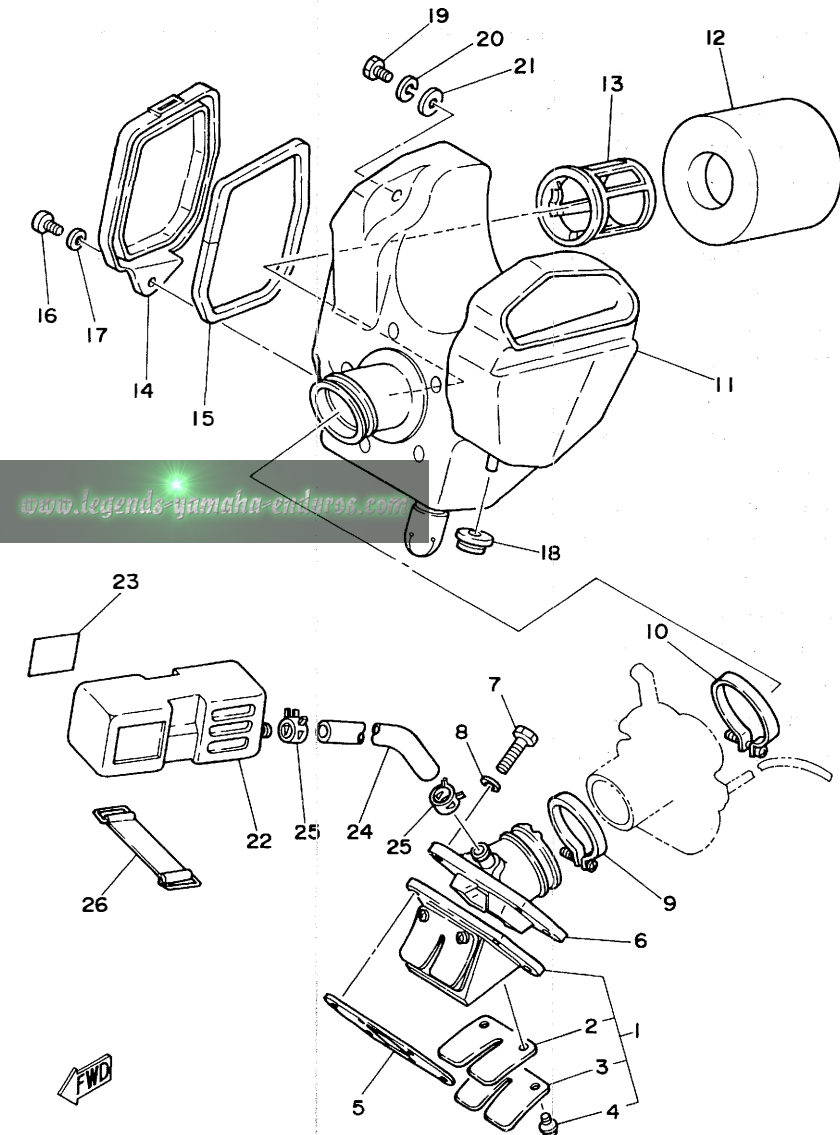
REF. NO.	PART NO.	DESCRIPTION	Q'TY	REMARKS
1	5X2-12460-00	RADIATOR ASSY	1	
2	4V2-12462-00	.CAP, radiator	1	
3	90446-09184	HOSE	1	
4	90467-09006	CLIP	1	
5	5X2-12481-00	PIPE 1	2	
6	5X2-12482-00	PIPE 2	1	
7	5X2-12483-00	PIPE 3	1	
8	90460-16192	CLAMP, hose	8	
9	5X2-12446-00	JOINT	1	
10	92506-06016	SCREW, Pan head	2	
11	93210-19026	O-RING	1	
12	93210-16275	O-RING	1	
13	4V2-12494-00	SEAL, PiPe 1	1	
14	90201-06073	WASHER, Plate	2	
15	92901-06100	WASHER, sPring	2	
16	95301-06600	NUT	2	
17	97301-06030	BOLT	2	
18	90201-06557	WASHER, Plate	2	
19	90480-15064	GROMMET	2	
20	90387-072E7	COLLAR	2	



B6

FIG. 6 INTAKE

REF. NO.	PART NO.	DESCRIPTION	Q'TY	REMARKS
1	1L8-13610-00	REED VALVE ASSY	1	
2	1L8-13613-00	•REED, valve	2	
3	311-13616-01	•STOPPER, reed valve	2	
4	97602-03108	•SCREW, Pan head with washer	4	
5	311-13621-01	GASKET, valve seat	1	
6	5X2-13565-00	JOINT, carburetor	1	
7	97301-06025	BOLT	4	
8	92901-06600	WASHER, Plate	4	
9	90460-43053	CLAMP, hose	1	
10	90460-51059	CLAMP, hose	1	
11	5X2-14401-00	AIR CLEANER CASE ASSY	1	
12	4V1-14451-00	ELEMENT, air cleaner	1	
13	4V1-14458-00	GUIDE	1	
14	4V1-14412-00	CAP, cleaner case 1	1	
15	4V1-14452-00	SEAL	1	
16	92501-06015	SCREW, Pan head	1	
17	92901-06600	WASHER, Plate	1	
18	90480-13197	GROMMET	1	
19	97301-06012	BOLT	2	
20	92901-06100	WASHER, spring	2	
21	90201-06067	WASHER, Plate	1	
22	5X2-13581-00	CHAMBER, air	1	
23	4V3-1441K-00	EMBLEM	1	
24	90445-15612	HOSE	1	
25	90467-16063	CLIP	2	
26	2T4-82131-00	BAND, battery	1	



B7

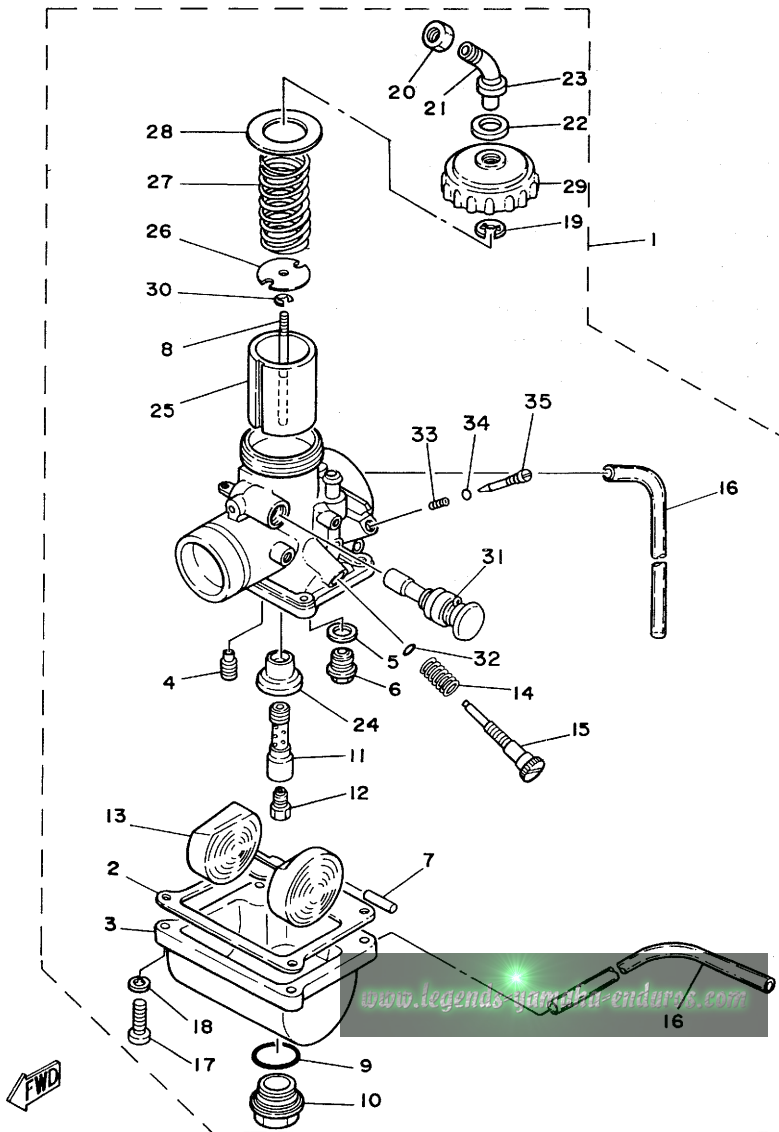
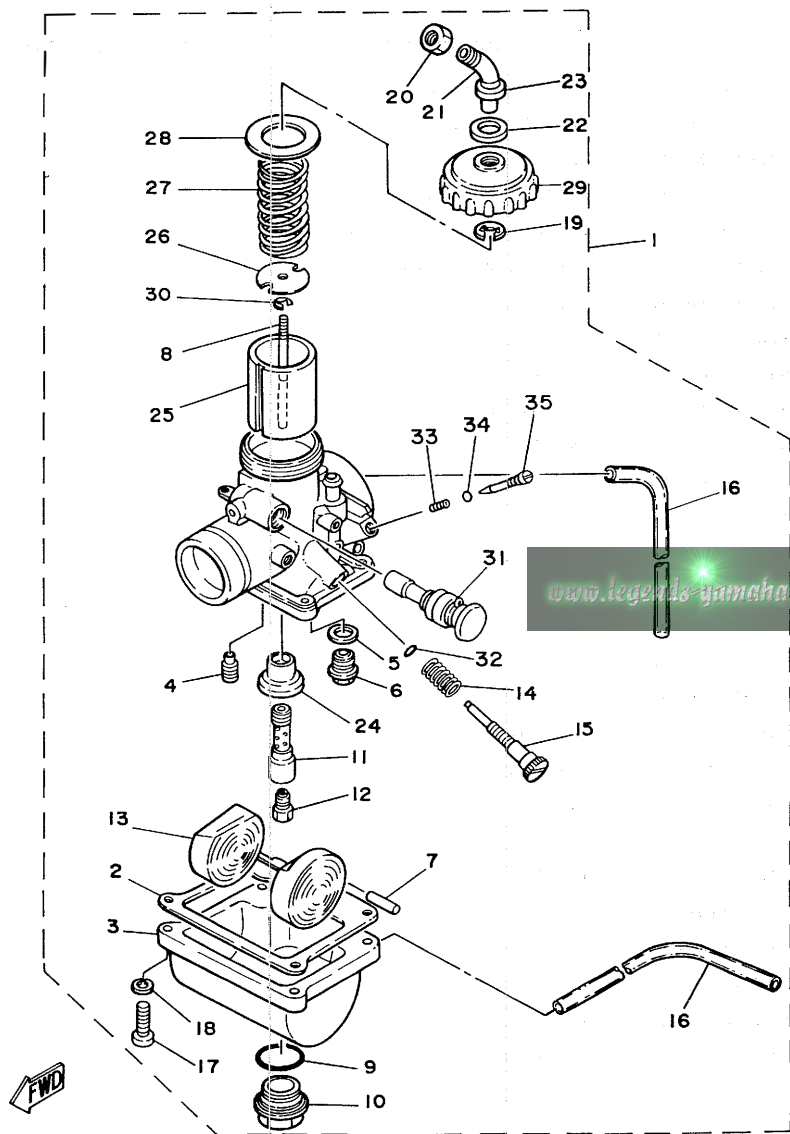


FIG. 7 CARBURETOR

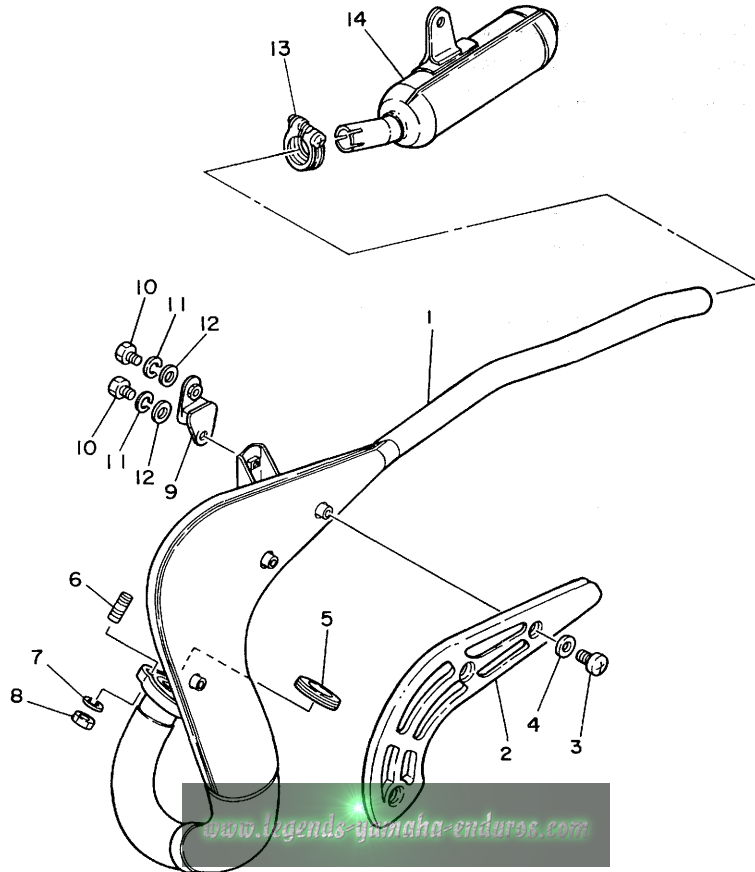
REF. NO.	PART NO.	DESCRIPTION	Q'TY	REMARKS
1	5X2-14101-00	CARBURETOR ASSY 1	1	
2	304-14184-00	•GASKET, float chamber	1	
3	539-14181-08	•BODY, float chamber 1	1	
4	260-14142-35	•JET, Pilot (#35.0)	1	
5	214-14195-00	•WASHER, needle valve	1	
6	168-14190-25	•NEEDLE VALVE ASSY	1	
7	127-14186-00	•PIN, float	1	
8	166-14116-13	•NEEDLE	1	
9	93210-18288	•O-RING	1	
10	3R1-14115-00	•PLUG, screw	1	
11	3R1-14141-30	•NOZZLE, main	1	
12	137-14143-40	•JET, main (#200)	1	UR
	137-14143-42	•JET, main (#210)	1	UR
	137-14143-44	•JET, main (#220)	1	UR
13	314-14185-00	•FLOAT	1	
14	493-14133-00	•SPRING, throttle stop	1	
15	443-14122-00	•SCREW, throttle	1	
16	183-14196-00	•PIPE	2	
17	98501-04016	•SCREW, Pan head	4	
18	92902-04100	•WASHER, spring	4	
19	363-14137-00	•CLIP	1	
20	802-14161-00	•NUT, cable adjusting	1	
21	1T9-14155-00	•GUIDE, cable	1	
22	509-14198-00	•GASKET	1	
23	1M1-14169-00	•CAP	1	
24	3R1-14153-00	•WASHER, main Jet	1	
25	2X6-14112-20	•VALVE, throttle 1	1	
26	246-14132-00	•STOPPER, cable	1	

FIG. 7 CARBURETOR



REF. NO.	PART NO.	DESCRIPTION	Q'TY	REMARKS
27	248-14131-00	•SPRING, throttle valve	1	
28	2A6-14126-00	•GASKET	1	
29	2A6-14158-00	•TOP, mixing chamber	1	
30	164-14137-00	•CLIP	1	
31	4U5-14171-00	•PLUNGER, starter	1	
32	214-14147-00	•O-RING	1	
33	174-14134-00	•SPRING, air adjusting	1	
34	354-14147-00	•O-RING	1	
35	525-14123-00	•SCREW, air adjusting	1	

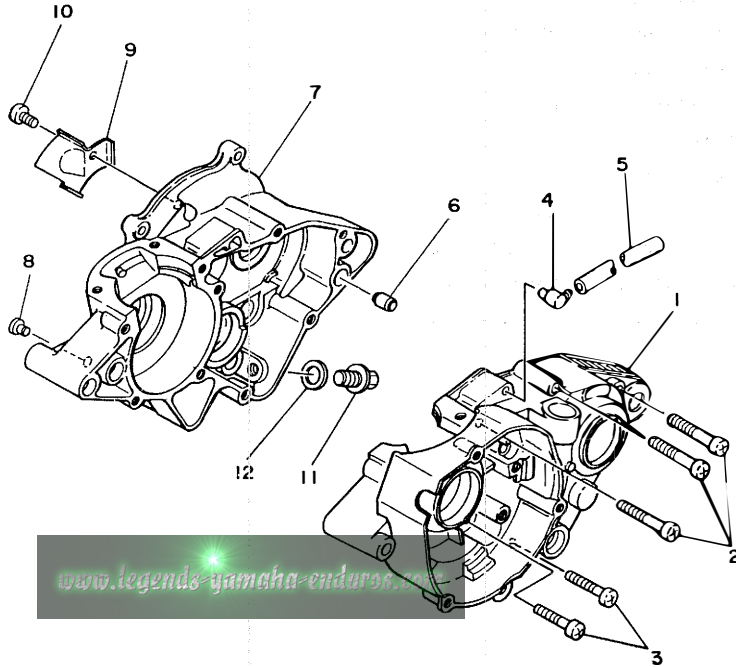
FIG. 8 EXHAUST



REF. NO.	PART NO.	DESCRIPTION	Q'TY	REMARKS
1	5X2-14610-00	EXHAUST PIPE ASSY 1	1	
2	5X2-14718-00	PROTECTOR, muffler 1	1	
3	98903-06008	SCREW, bind	3	
4	90202-06010	WASHER, Plate	3	
5	152-14613-00	GASKET, exhaust Pipe	1	
6	90116-08166	BOLT, stud	2	
7	92901-08100	WASHER, sPring	2	
8	95301-08600	NUT	2	
9	565-14771-00	STAY, muffler 1	1	
10	97301-06016	BOLT	2	
11	92901-06100	WASHER, sPring	2	
12	92901-06600	WASHER, Plate	2	
13	3R0-14788-00	BAND, silencer	1	
14	5X2-14753-00	SILENCER, exhaust	1	



FIG. 9 CRANKCASE

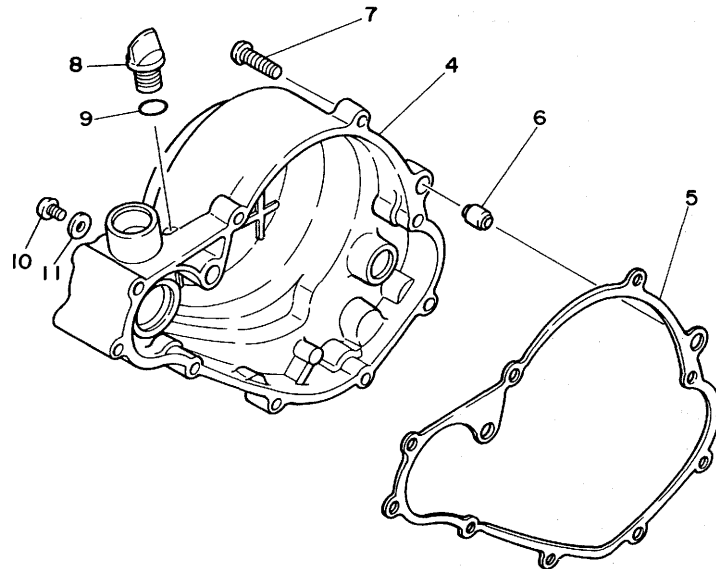


REF. NO.	PART NO.	DESCRIPTION	Q'TY	REMARKS
1	4V0-15111-02	CRANKCASE 1	1	
2	92506-06045	SCREW, Pan head	6	
3	92506-06035	SCREW, Pan head	3	
4	353-13115-01	CONNECTOR, suction PiPe	1	
5	90445-08376	HOSE	1	
6	91830-22016	PIN, dowel	2	
7	5X2-15121-00	CRANKCASE 2	1	
8	90338-07011	PLUG	1	
9	5X2-15113-00	PLATE	1	
10	92501-06010	SCREW, Pan head	1	
11	90340-12059	PLUG, straight screw	1	
12	90430-12038	GASKET	1	

www.legends-yamaha-enduros.com



FIG. 10 CRANKCASE COVER



REF. NO.	PART NO.	DESCRIPTION	Q'TY	REMARKS
1	4V0-15411-00	COVER, crankcase 1	1	
2	4V0-15451-02	GASKET, crankcase cover	1	
3	92506-06030	SCREW, Pan head	3	
4	5X2-15421-00	COVER, crankcase 2	1	
5	5X2-15462-00	GASKET, crankcase cover 3	1	
6	91830-21014	PIN, dowel	2	
7	92506-06025	SCREW, Pan head	7	
8	4J2-15363-00	PLUG, oil	1	
9	93210-14104	O-RING	1	
10	92506-06008	SCREW, Pan head	1	
11	90430-06016	GASKET	1	

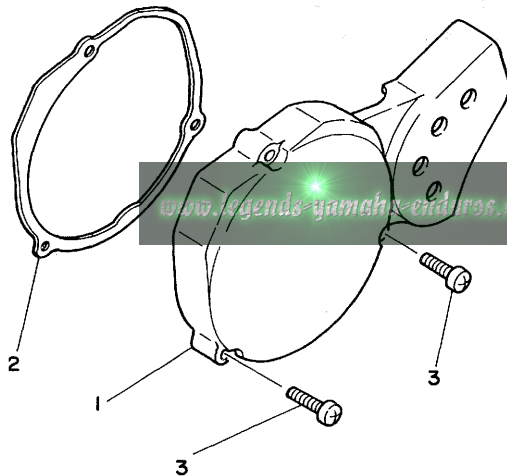
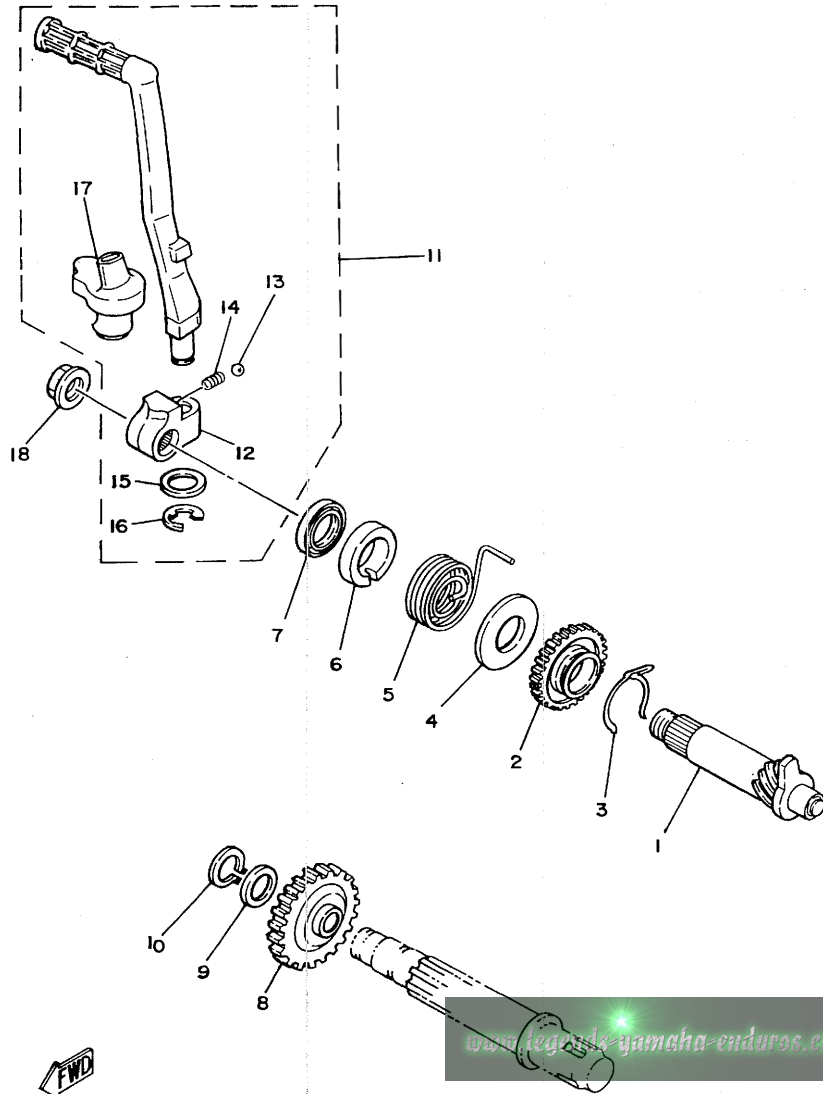


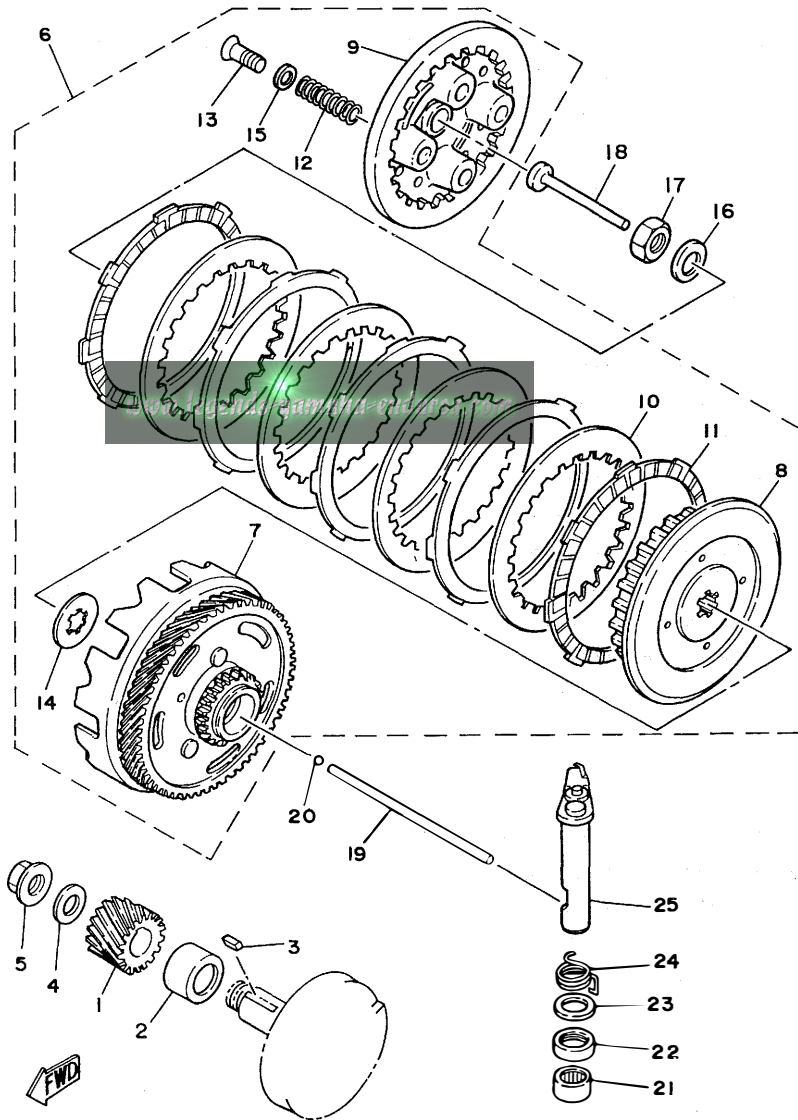
FIG. 11 KICK STARTER



REF. NO.	PART NO.	DESCRIPTION	Q'TY	REMARKS
1	4V0-15660-00	KICK AXLE ASSY	1	
2	4V0-15641-00	GEAR, kick (24T)	1	
3	90468-26046	CLIP	1	
4	90201-154A1	WASHER, Plate	1	
5	90508-26464	SPRING, torsion	1	
6	4V0-15664-00	GUIDE, sPring	1	
7	93109-15001	OIL SEAL	1	
8	4V0-15651-00	GEAR, sPcket idle (25T)	1	
9	102-18137-00-10	WASHER 1	1	
10	93410-12003	CIRCLIP	1	
11	4V0-15620-00	KICK CRANK ASSY	1	
12	4V0-15621-00	•BOSS, kick crank	1	
13	93507-32009	•BALL	1	
14	90501-12081	•SPRING, comPression	1	
15	90201-12631	•WASHER, Plate	1	
16	93430-08007	•CIRCLIP	1	
17	4V0-15618-00	•COVER, kick lever	1	
18	90179-10272	NUT	1	



FIG. 12 CLUTCH

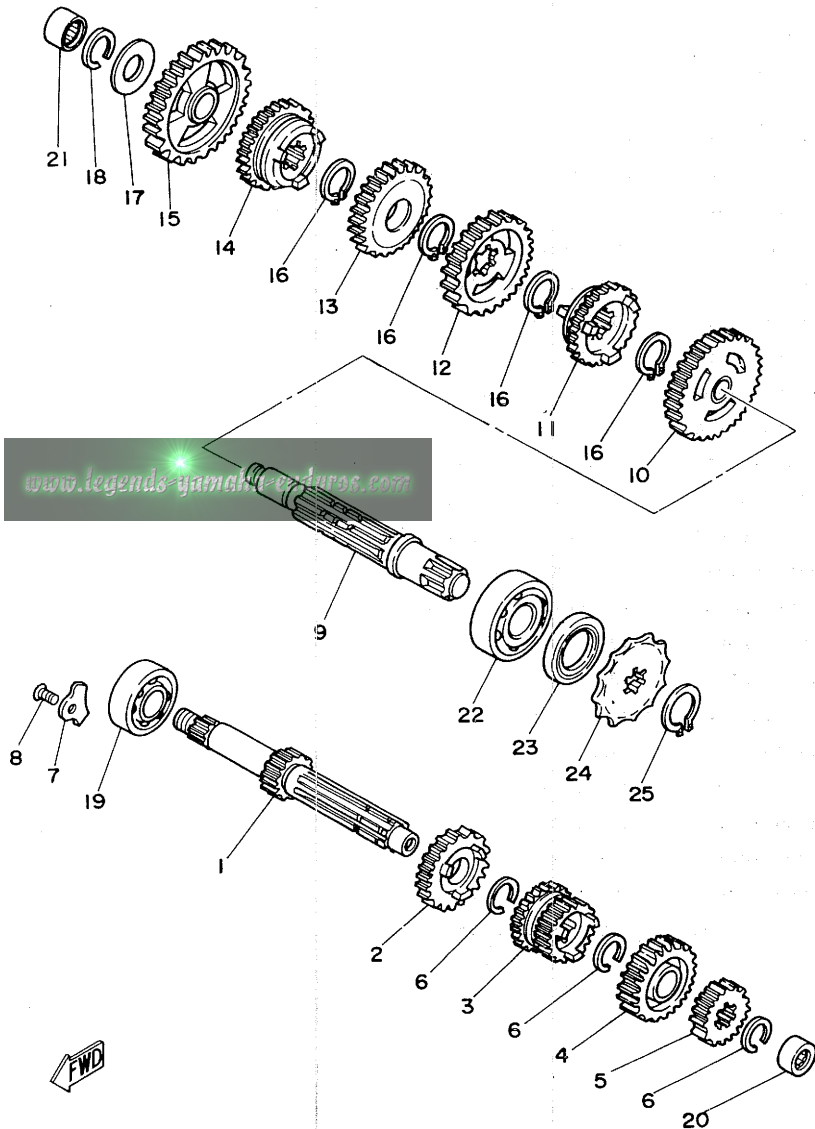


REF. NO.	PART NO.	DESCRIPTION	Q'TY	REMARKS
1	5X2-16111-00	GEAR, Primary drive	1	
2	90387-20163	COLLAR	1	
3	90282-05001	KEY, straight	1	
4	90208-12015	WASHER, conical spring	1	
5	90179-12335	NUT	1	
6	4V1-16300-02	CLUTCH ASSY	1	
7	4V1-16150-01	•PRIMARY DRIVEN GEAR COMP.	1	
8	1V1-16371-01	•BOSS, clutch	1	
9	4Y2-16351-01	•PLATE, Pressure 1	1	
10	598-16324-00	•PLATE, clutch 1	4	
11	4V0-16321-00	•PLATE, friction	5	
12	90501-20125	•SPRING, compression	4	
13	98701-05020	•SCREW, flat head	4	
14	4V0-16154-00	•PLATE, thrust 1	1	
15	90201-05775	•WASHER, Plate	4	
16	90208-12015	WASHER, conical spring	1	
17	90170-12060	NUT	1	
18	137-16356-00	ROD, Push 1	1	
19	2X3-16357-00	ROD, Push 2	1	
20	93503-16010	BALL	1	
21	93315-21429	BEARING, cylindrical	1	
22	93109-14021	OIL SEAL	1	
23	90201-14411	WASHER, Plate	1	
24	90508-18463	SPRING, torsion	1	
25	4V1-16380-00	PUSH LEVER ASSY	1	

B14

FIG. 13 TRANSMISSION

REF. NO.	PART NO.	DESCRIPTION	Q'TY	REMARKS
1	4V0-17411-01	AXLE, main	1	
2	4V0-17151-02	GEAR, 5th Pinion (20T)	1	
3	4V0-17131-00	GEAR, 3rd/4th Pinion (19T,21T)	1	
4	4V0-17161-02	GEAR, 6th Pinion	1	
5	4V0-17121-00	GEAR, 2nd Pinion (16T)	1	
6	93440-16089	CIRCLIP	3	
7	3R4-15383-00	PLATE, bearing cover	2	
8	92701-06012	SCREW, flat head	2	
9	4V0-17421-00	AXLE, drive	1	
10	4V0-17221-00	GEAR, 2nd wheel (33T)	1	
11	4V0-17261-02	GEAR, 6th wheel	1	
12	4V0-17231-00	GEAR, 3rd wheel (31T)	1	
13	4V0-17241-00	GEAR, 4th wheel (28T)	1	
14	4V0-17251-02	GEAR, 5th wheel	1	
15	4V0-17211-00	GEAR, 1st wheel (36T)	1	
16	93410-20038	CIRCLIP	4	
17	164-17427-00-06	SHIM 1 (0.6T)	1	
18	93440-15012	CIRCLIP	1	
19	93306-20303	BEARING (B6203Z)	1	
20	93311-31249	BEARING, cylindrical	1	
21	93315-31502	BEARING, cylindrical	1	
22	93306-20401	BEARING (B6204)	1	
23	93102-20143	OIL SEAL	1	
24	174-17461-30	SPROCKET, drive (13T)	1	STD
	174-17461-20	SPROCKET, drive (12T)	1	AP
	174-17461-40	SPROCKET, drive (14T)	1	AP
25	93410-18062	CIRCLIP	1	



B15

www.legends-yamaha-motor.com

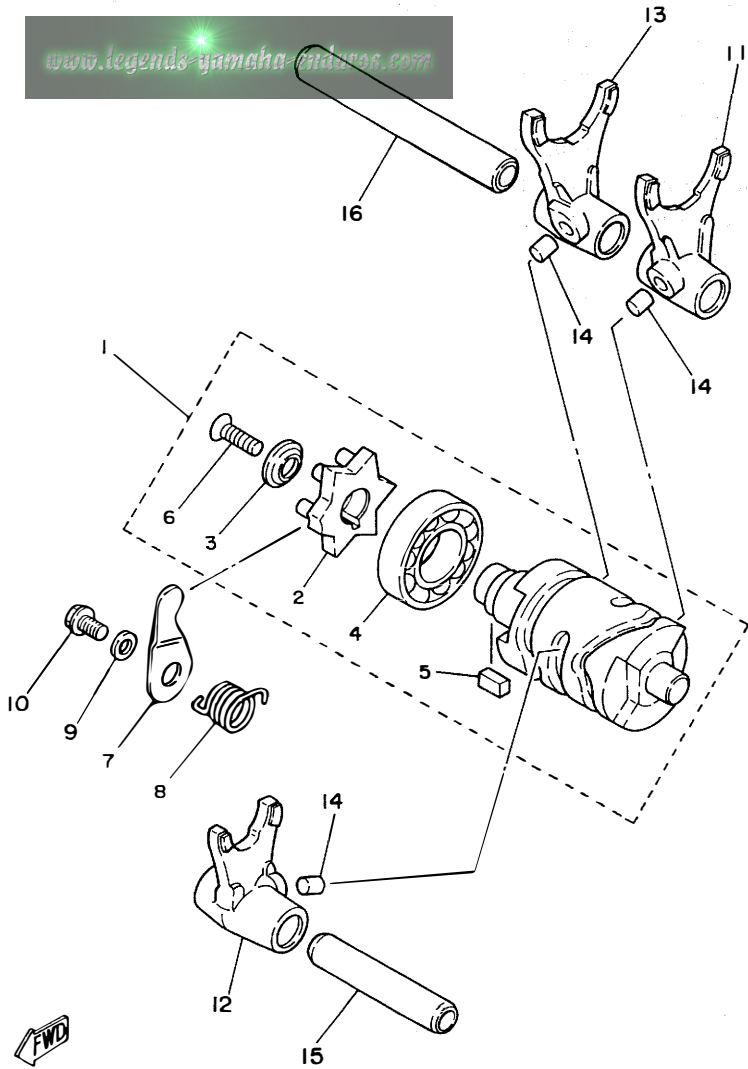
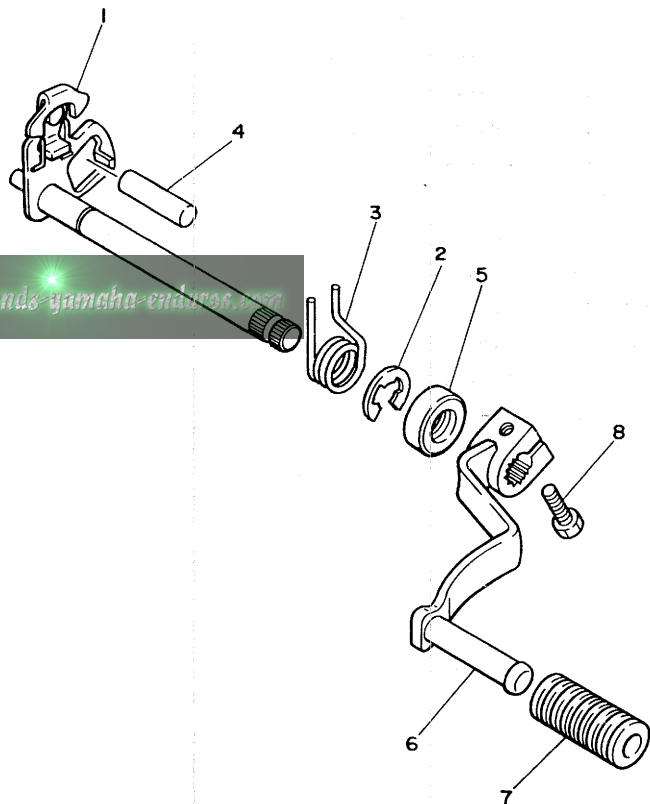


FIG. 14 SHIFT CAM.FORK

REF. NO.	PART NO.	DESCRIPTION	Q'TY	REMARKS
1	4V0-18540-00	SHIFT CAM ASSY	1	
2	3R4-18185-00	•SEGMENT	1	
3	3R4-18561-00	•PLATE, side 1	1	
4	93306-00422	•BEARING	1	
5	90282-04036	•KEY, straight	1	
6	98701-05016	•SCREW, flat head	1	
7	4V0-18148-00	LEVER, stopper	1	
8	90508-26462	SPRING, torsion	1	
9	90201-06655	WASHER, Plate	1	
10	90109-06001	BOLT	1	
11	4V0-18511-00	FORK, shift 1	1	
12	4V0-18512-00	FORK, shift 2	1	
13	4V0-18513-00	FORK, shift 3	1	
14	90250-06013	PIN, straight	3	
15	3R4-18531-00	BAR, shift fork guide 1	1	
16	3R4-18535-00	BAR, shift fork guide 2	1	

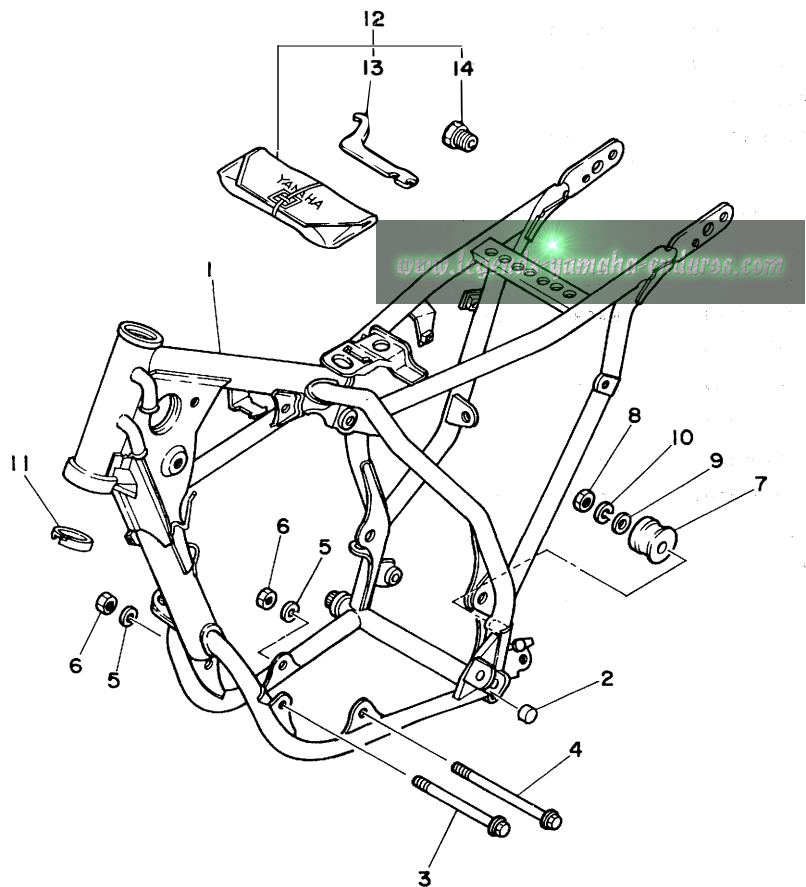
FIG. 15 SHIFT SHAFT.PEDAL

REF. NO.	PART NO.	DESCRIPTION	Q'TY	REMARKS
1	5X2-18101-00	SHIFT SHAFT ASSY	1	
2	93430-10016	CIRCLIP	1	
3	90508-32465	SPRING, torsion	1	
4	93608-30128	PIN, dowel	1	
5	93109-12012	OIL SEAL	1	
6	4V0-18111-00	PEDAL, shift	1	
7	132-18113-01	COVER, shift Pedal	1	
8	97321-06020	BOLT	1	



C3

FIG. 16 FRAME• TOOL



REF. NO.	PART NO.	DESCRIPTION	Q'TY	REMARKS
1	5X2-21110-00-33	FRAME COMP	1	yamaha black
2	90339-11001	PLUG	1	
3	90105-08024	BOLT, washer based	1	
4	90105-08189	BOLT, washer based	1	
5	92901-08200	WASHER, Plain	2	
6	90185-08089	NUT, self-locking	2	
7	2K6-22178-00	TENSIONER	1	
8	95301-08600	NUT	1	
9	90201-08753	WASHER, Plate	1	
10	92901-08100	WASHER, sPring	1	
11	5X2-23462-00	SEAL, steering	1	
12	2X6-28100-10	TOOL KIT	1	
13	1M1-28137-00	•SPRING SEAT WRENCH	1	
14	2K7-85555-00	•PULLER, rotor	1	



FIG. 17 FRONT FENDER•REAR FENDER

REF. NO.	PART NO.	DESCRIPTION	Q'TY	REMARKS
1	5X2-21511-10	FENDER, front	1	clean white
2	90201-06557	WASHER, Plate	4	
3	90209-06187	WASHER	4	
4	97302-06020	BOLT	4	
5	92902-06100	WASHER, sPring	4	
6	4V1-21611-10	FENDER, rear	1	clean white
7	4V1-21621-00	FLAP	1	
8	92502-06016	SCREW, Pan head	3	
9	92902-06100	WASHER, sPring	3	
10	90201-06557	WASHER, Plate	3	
11	90201-08730	WASHER, Plate	2	
12	97301-08020	BOLT	1	
13	97301-08022	BOLT	1	
14	95301-08800	NUT, crown	2	
15	92901-08100	WASHER, sPring	2	

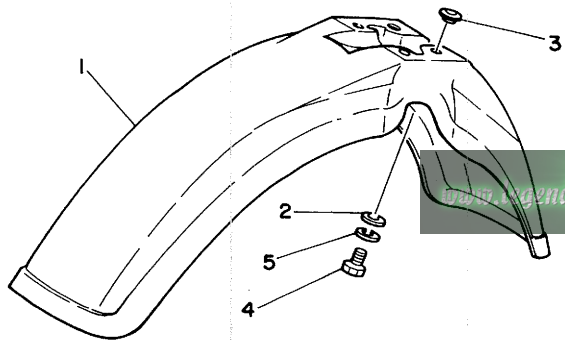
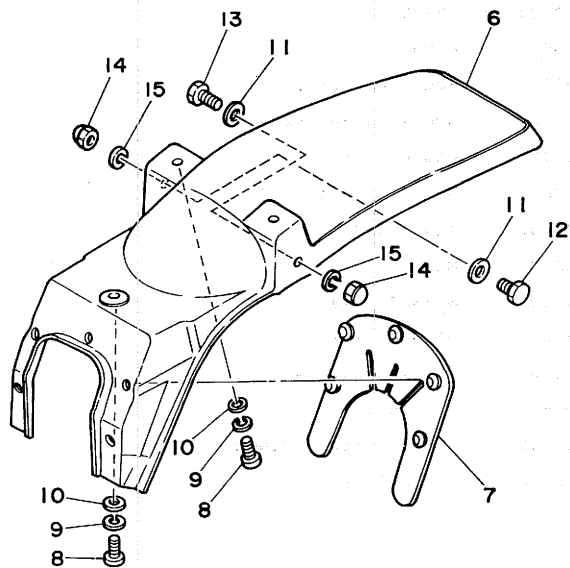


FIG. 18 SIDE COVER

REF. NO.	PART NO.	DESCRIPTION	Q'TY	REMARKS
1	5X2-21711-10	COVER, side 1	1	clean white
2	431-24181-00	DAMPER, locating 1	2	
3	5X2-21781-10	EMBLEM 1	1	
4	92501-06015	SCREW, Pan head	2	
5	92901-06100	WASHER, sPring	2	
6	90201-06557	WASHER, Plate	2	
7	5X2-21721-10	COVER, side 2	1	clean white
8	5X2-21781-10	EMBLEM 1	1	
9	92501-06015	SCREW, Pan head	2	
10	92901-06100	WASHER, sPring	2	
11	90201-06557	WASHER, Plate	2	

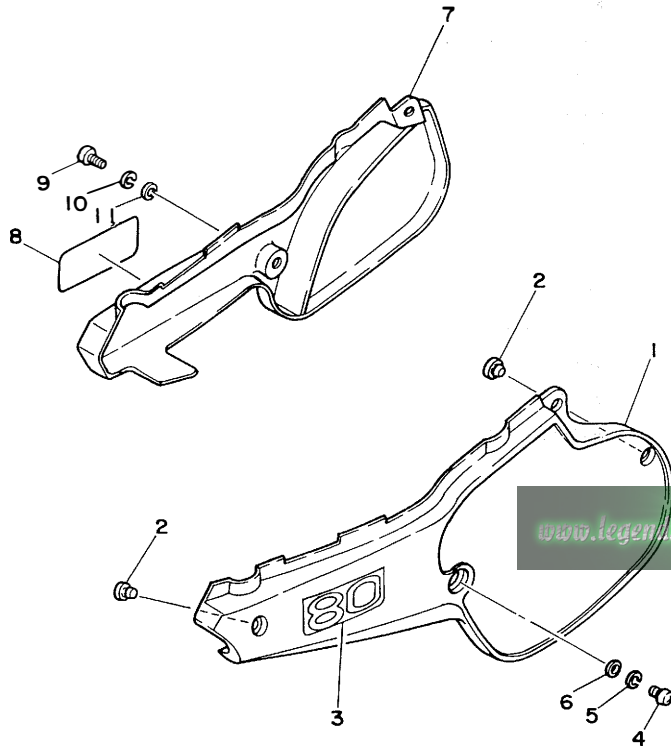
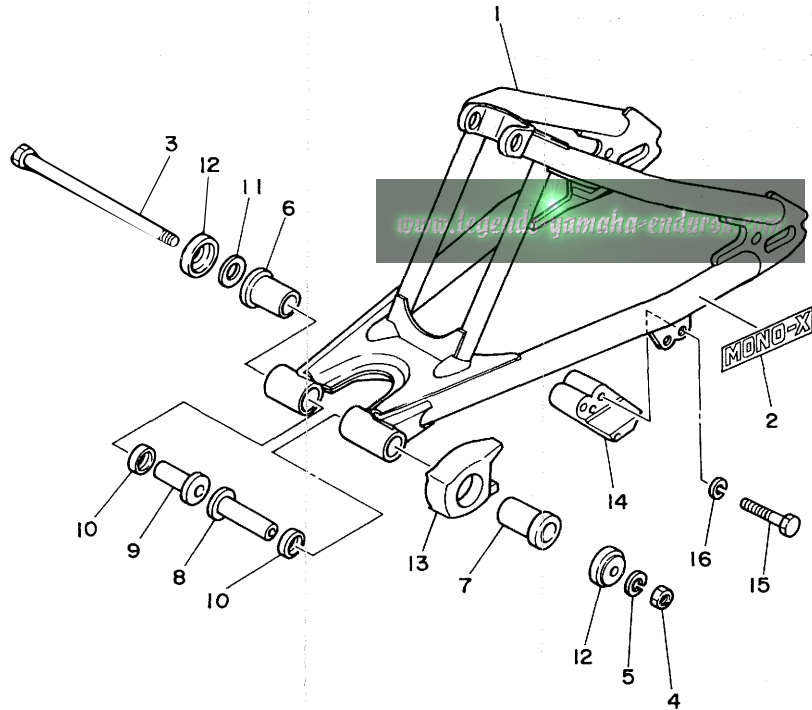


FIG. 19 REAR ARM

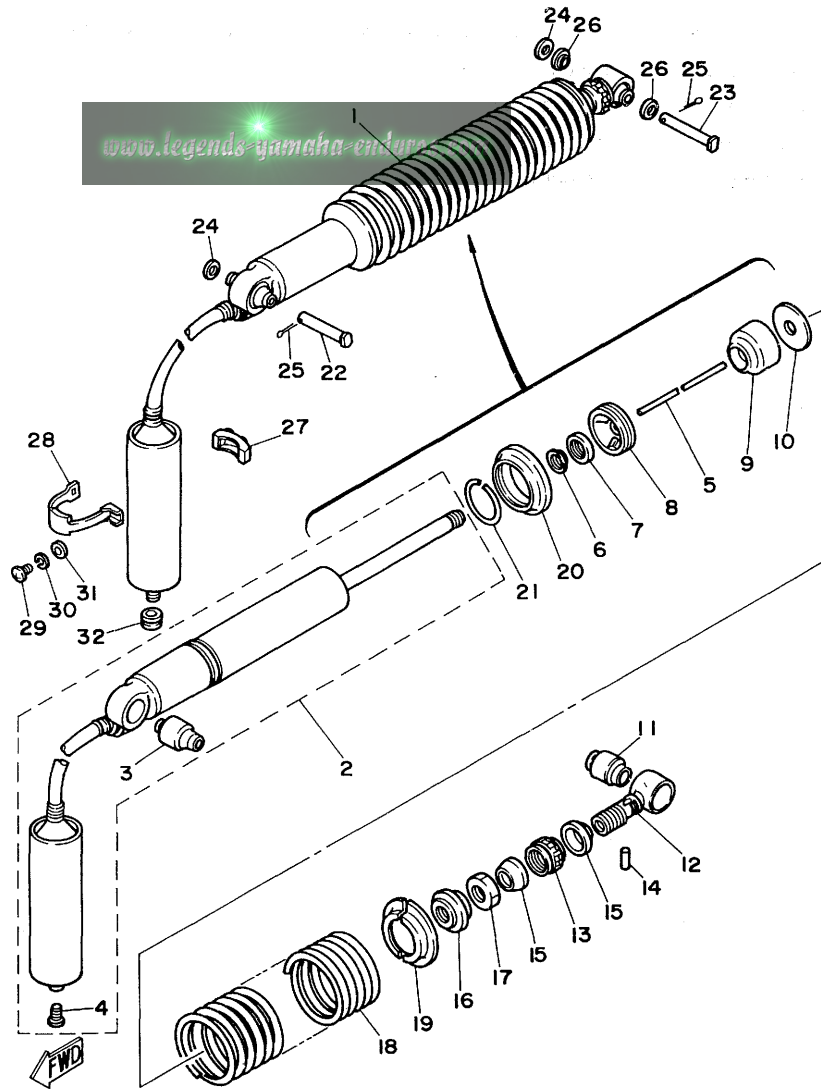


REF. NO.	PART NO.	DESCRIPTION	Q'TY	REMARKS
1	5X2-22110-00-35	REAR ARM COMP.	1	silver
2	4V0-2218A-00	EMBLEM, rear arm	2	for canada
3	4V1-22141-00	SHAFT, Pivot	1	
4	95311-12700	NUT	1	
5	92901-12100	WASHER, sPring	1	
6	90386-18099	BUSH	1	
7	90386-18109	BUSH	1	
8	90387-121F6	COLLAR	1	
9	90387-121F7	COLLAR	1	
10	93109-18020	OIL SEAL	2	
11	401-22127-00	SHIM	1	
12	401-22128-01	SEAL, Guard	2	
13	4V1-22151-00	SEAL, Guard	1	
14	4V0-22199-00	SUPPORT, chain	1	
15	97301-06045	BOLT	2	
16	92901-06100	WASHER, sPring	2	



C7

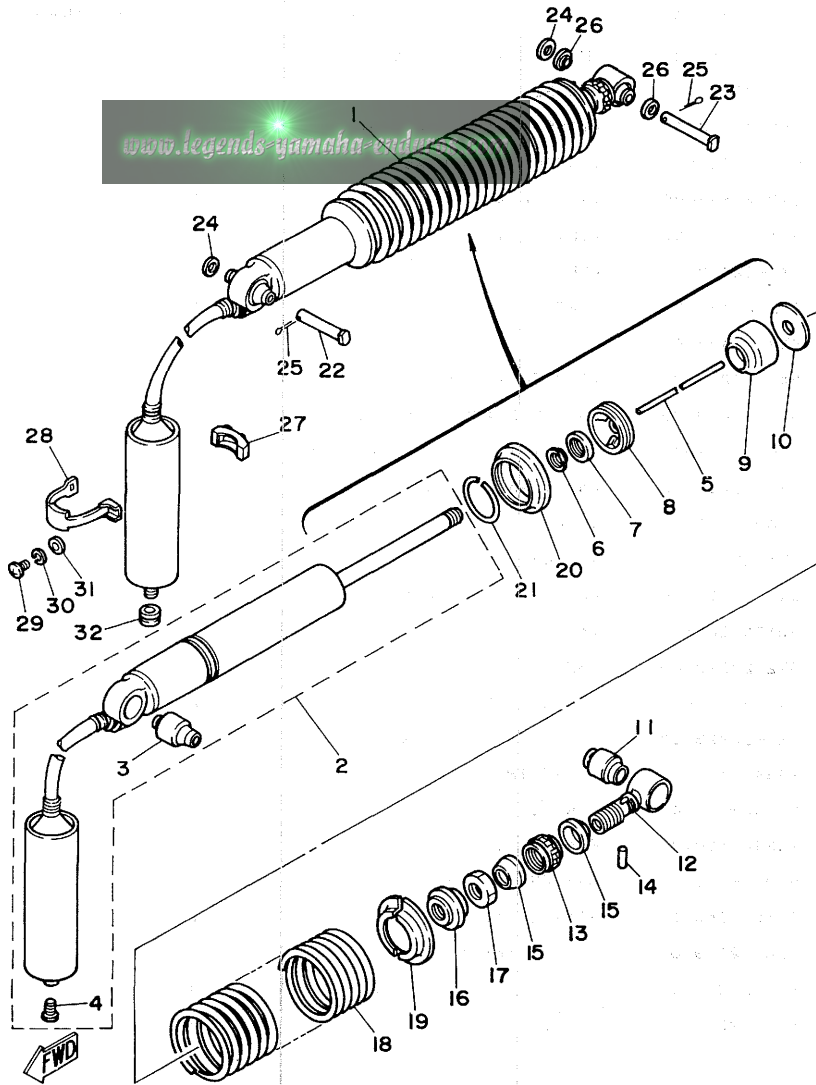
FIG. 20 REAR SUSPENSION



REF. NO.	PART NO.	DESCRIPTION	Q'TY	REMARKS
1	5X2-22210-00	SHOCK ABSORBER ASSY, rear	1	
2	5X2-22401-00	•DUMPER SUB ASSY	1	
3	2X6-22216-00	••BUSH, rear shock absorber	1	
4	98501-04005	••SCREW, Pan head	1	
5	5X2-22489-00	•ROD, Push	1	
6	3R1-22475-00	•SEAL, dust	1	
7	2X6-22473-00	•SEAL, housing	1	
8	5X2-22472-00	•CAP, case	1	
9	5X2-22493-00	•BUMP, stoP	1	
10	5X2-22228-00	•SUPPORT, bump stoP	1	
11	5X2-22409-00	•UPPER BRACKET SUB ASSY	1	
12	2X6-22216-00	•BUSH, rear shock absorber	1	
13	3R4-22497-00	•NUT, adjusting	1	
14	93604-26132	•PIN, dowel	1	
15	3R4-22221-01	•COVER	2	
16	3R4-22213-00	•SEAT, sPring upper	1	
17	90170-20213	•NUT	1	
18	5X2-22212-00	•SPRING	1	
19	5X2-22214-00	•GUIDE, sPring 1	2	
20	5X2-22223-00	•SEAT, sPring lower	1	
21	93440-42101	•CIRCLIP	1	
22	90240-10064	PIN, clevis	1	
23	90240-10073	PIN, clevis	1	
24	92901-10600	WASHER, Plate	2	
25	91401-25020	PIN, cotter	2	
26	2X6-22129-00	COVER, thrust 2	2	
27	5X2-22261-00	DAMPER, sub tank	1	
28	5X2-22262-00	HOLDER, sub tank	1	

FIG. 20 REAR SUSPENSION

REF. NO.	PART NO.	DESCRIPTION	Q'TY	REMARKS
29	92501-06012	SCREW, Pan head	1	
30	92902-06100	WASHER, sPring	1	
31	92902-06600	WASHER	1	
32	90480-17213	GROMMET	1	



C9

www.legends-yamaha-enduros.com

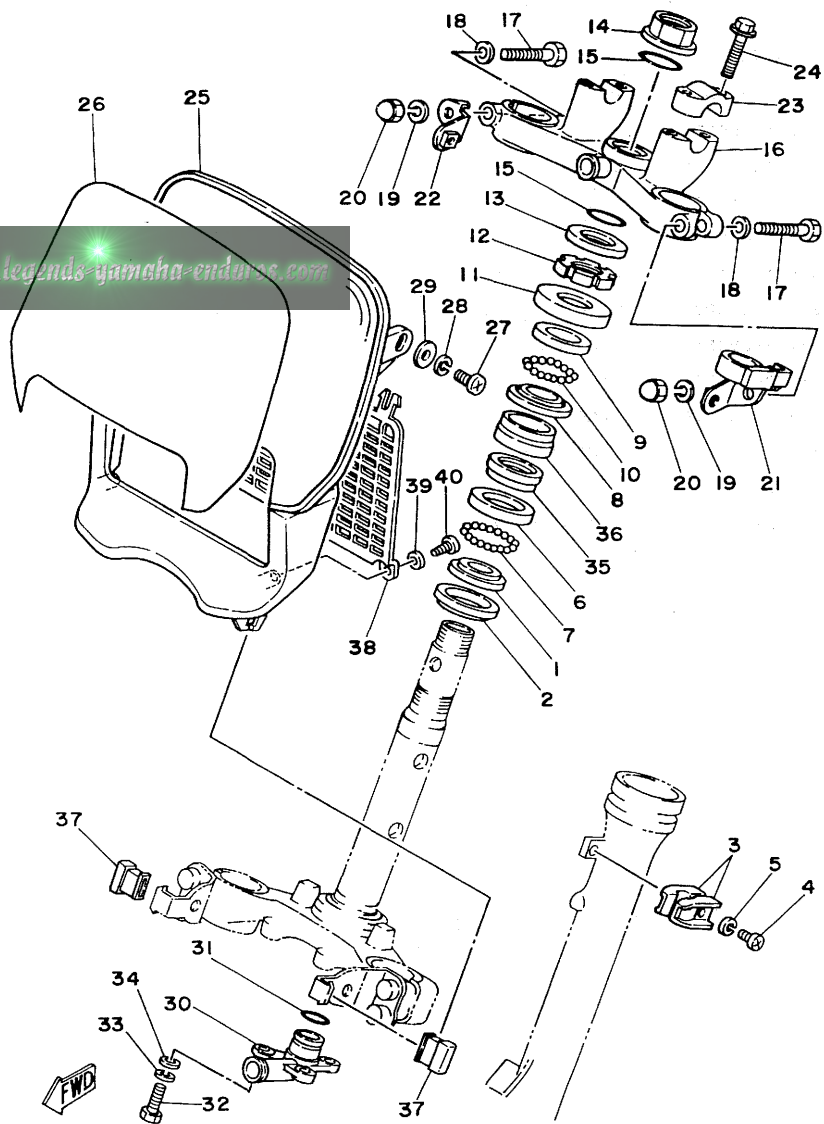


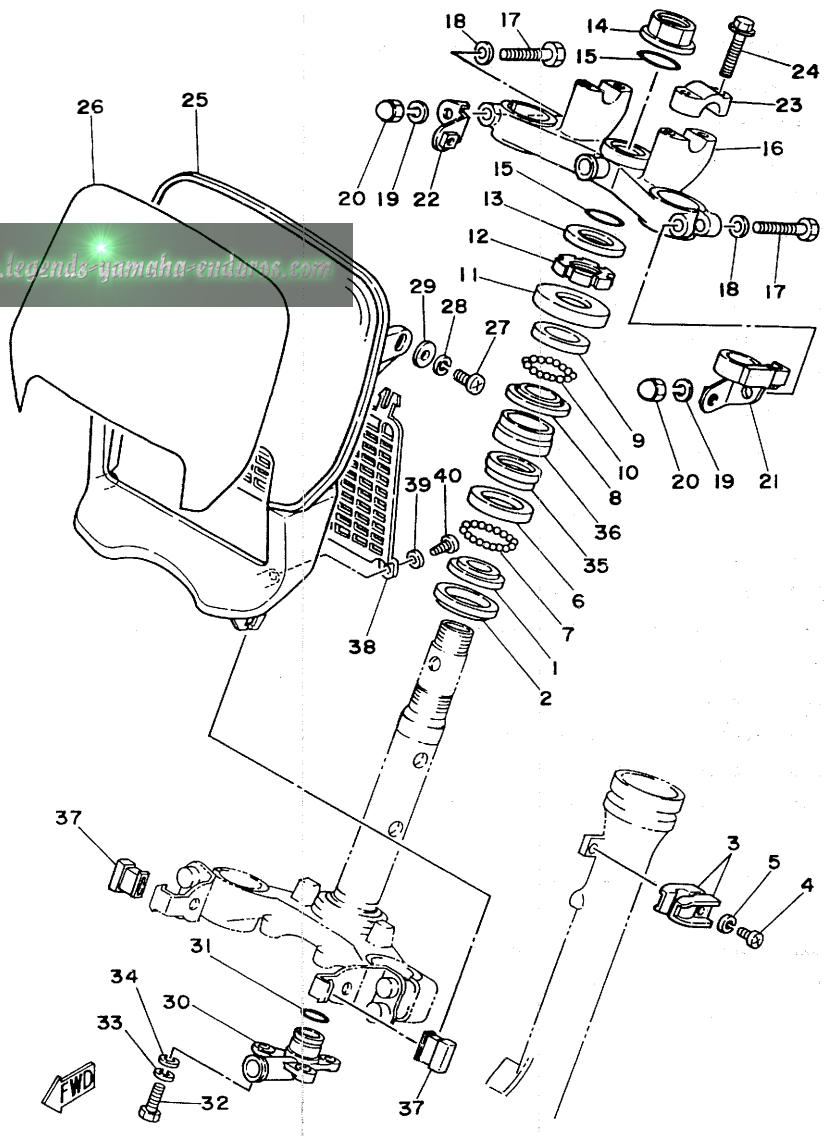
FIG. 21 STEERING

REF. NO.	PART NO.	DESCRIPTION	Q'TY	REMARKS
1	156-23411-00	RACE, ball 1	1	
2	164-23462-00	SEAL, steering	1	
3	90462-14055	CLAMP	2	
4	92501-06012	SCREW, Pan head	1	
5	92901-06100	WASHER, sPring	1	
6	156-23412-00	RACE, ball 2	1	
7	93501-04011	BALL	19	
8	122-23411-00	RACE, ball 1	1	
9	122-23412-00	RACE, ball 2	1	
10	93503-16010	BALL	22	
11	122-23416-00	COVER, ball race 2	1	
12	90179-25033	NUT	1	
13	90201-237E8	WASHER, Plate	1	
14	90179-22330	NUT	1	
15	93210-23505	O-RING	2	
16	5X2-23435-00-98	CROWN, handle	1	low gloss black
17	97301-08050	BOLT	2	
18	92901-08600	WASHER, Plate	2	
19	92901-08100	WASHER, sPring	2	
20	95301-08800	NUT, crown	2	
21	5X2-23318-00	HOLDER, cable 1	1	
22	5X2-23486-00	STAY, Plate	1	
23	1E6-23441-00-98	HOLDER, handle upper	2	low gloss black
24	95821-08035	BOLT, flange	4	
25	5X2-23485-10	PLATE, number	1	
26	5X2-21785-10	EMBLEM 5	1	
27	92501-06015	SCREW, Pan head	2	

FIG. 21 STEERING

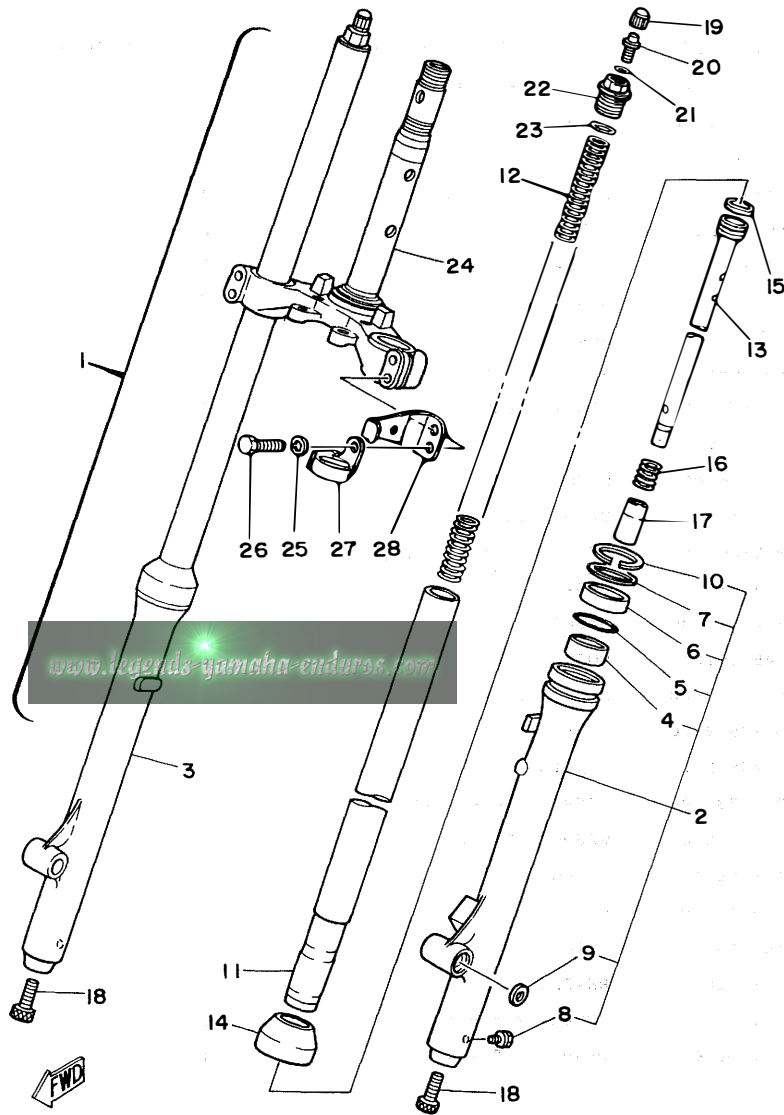
REF. NO.	PART NO.	DESCRIPTION	Q'TY	REMARKS
28	92901-06100	WASHER, sPring	2	
29	90201-06557	WASHER, Plate	2	
30	5X2-23491-00	JOINT	1	
31	93210-21276	O-RING	1	
32	97301-06020	BOLT	3	
33	92901-06100	WASHER, sPring	3	
34	92901-06600	WASHER, Plate	3	
35	93102-29256	OIL SEAL	1	
36	93102-28257	OIL SEAL	1	
37	5X2-23445-00	DAMPER	2	
38	5X2-23472-00	PROTECTOR	1	
39	92902-05200	WASHER	2	
40	97702-50512	SCREW, taPPing	2	

www.legends-yamaha-enduros.com



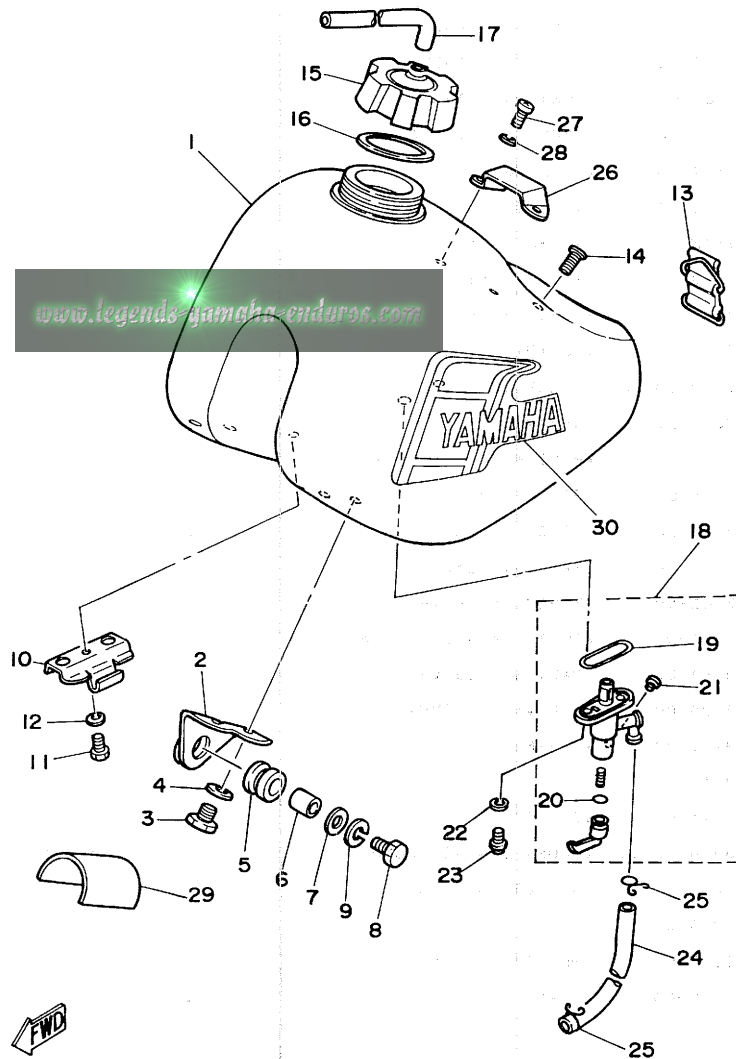
C11

FIG. 22 FRONT FORK



REF. NO.	PART NO.	DESCRIPTION	Q'TY	REMARKS
1	5X2-23101-L0	FRONT FORK ASSY	1	
2	4V1-23140-L0	•FORK UNIT ASSY 2	1	
3	4V1-23130-L0	•FORK UNIT ASSY	1	
4	4V1-23135-L0	••METAL, slide 2	2	
5	4V1-23147-L0	••O-RING	2	
6	4V1-23145-L0	••OIL SEAL	2	
7	4V1-23146-L0	••WASHER, oil seal	2	
8	2A6-23119-00	••PLUG, drain	2	
9	462-23392-02	••WASHER, sPecial	2	
10	4V1-23156-L0	••CLIP, oil seal	2	
11	4V1-23110-L0-93	•INNER TUBE COMP.1	2	chrome-Plated
12	4V1-23351-L0	•SPRING	2	
13	5X2-23171-L0	•PISTON, front fork	2	
14	4V1-23144-L0	•SEAL, dust	2	
15	1E7-23157-00	•RING, Piston	2	
16	2X6-23151-00	•SPRING, rebound	2	
17	1L9-23166-00	•TAPER, sPindle	2	
18	3M7-23181-00	•BOLT, hexa8on socket head	2	
19	4V1-23184-L0	•CAP, air valve	2	
20	5K7-23190-00	•AIR VALVE COMP.	2	
21	3H3-23147-00	•O-RING	2	
22	4V1-23111-L0	•BOLT, caP	2	
23	1E7-23114-00	•GASKET	2	
24	5X2-23340-L0-90	•UNDER BRACKET COMP.	1	uni chrome (bl-ack)
25	92902-08100	•WASHER, sPring	4	
26	97321-08040	•BOLT	4	
27	5X2-23317-00	•HOLDER, cable	1	
28	5X2-2317E-00	•STAY	2	

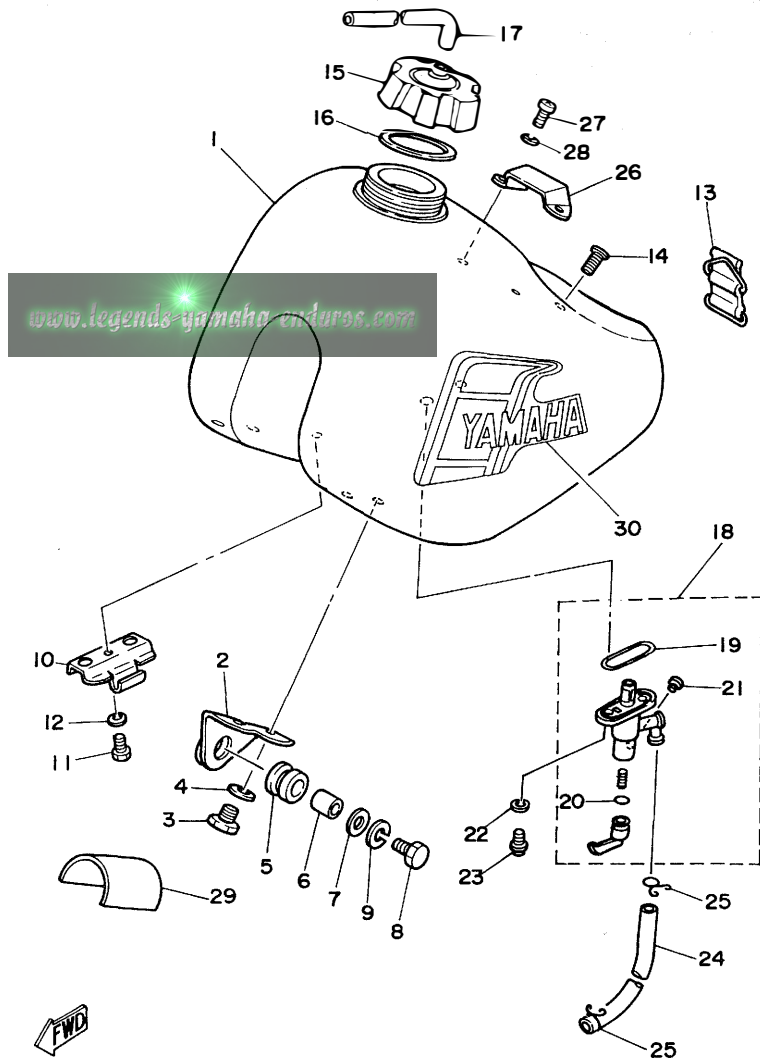
FIG. 23 FUEL TANK



REF. NO.	PART NO.	DESCRIPTION	Q'TY	REMARKS
1	5X2-24110-10	FUEL TANK COMP.	1	clean white
2	5X2-24157-00	STAY, fuel tank 1	2	
3	97301-06012	BOLT	4	
4	92901-06100	WASHER, sPring	4	
5	90480-18290	GROMMET	2	
6	90387-07598	COLLAR	2	
7	90201-06072	WASHER, Plate	2	
8	97321-06030	BOLT	2	
9	92901-06100	WASHER, sPring	2	
10	5X2-2415F-00	STAY, chamber	1	
11	97301-06010	BOLT	1	
12	92901-06100	WASHER, sPring	1	
13	3R3-24173-00	BAND, tank fitting 1	1	
14	98902-06014	SCREW, bind	1	
15	5X7-24611-00	BODY, caP	1	
16	5X7-24612-00	GASKET, caP	1	
17	90445-09104	HOSE	1	
18	2K5-24500-00	FUEL COCK ASSY 1	1	
19	214-24512-00	•GASKET	1	
20	1A0-24512-00	•O-RING	1	
21	619-24535-00	•SCREW, lever fitting	1	
22	90202-06010	WASHER, Plate	2	
23	90149-06011	SCREW	2	
24	90445-11149	HOSE	1	
25	90467-10008	CLIP	2	
26	5X7-2412F-00	BRACKET, seat	1	
27	92501-06012	SCREW, Pan head	2	
28	92901-06100	WASHER, sPring	2	

FIG. 23 FUEL TANK

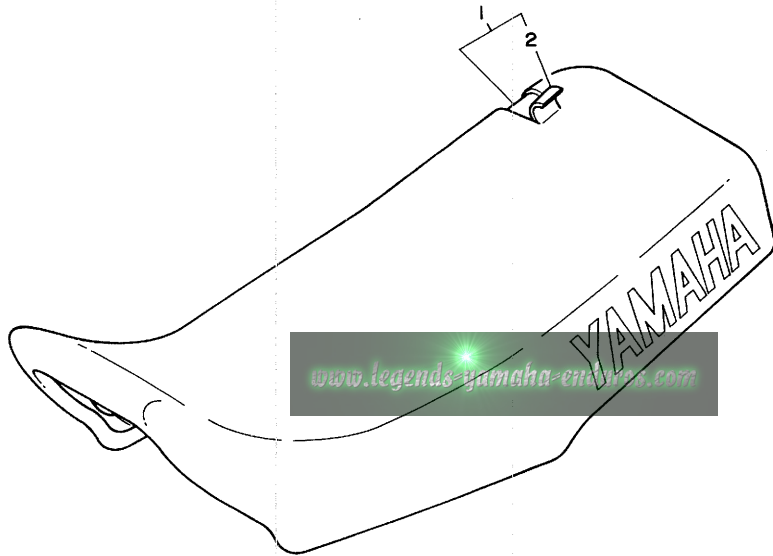
REF. NO.	PART NO.	DESCRIPTION	Q'TY	REMARKS
29	5X2-24183-00	DAMPER, locatin# 3	1	
30	5X2-24240-19	GRAPHIC SET	1	



C14

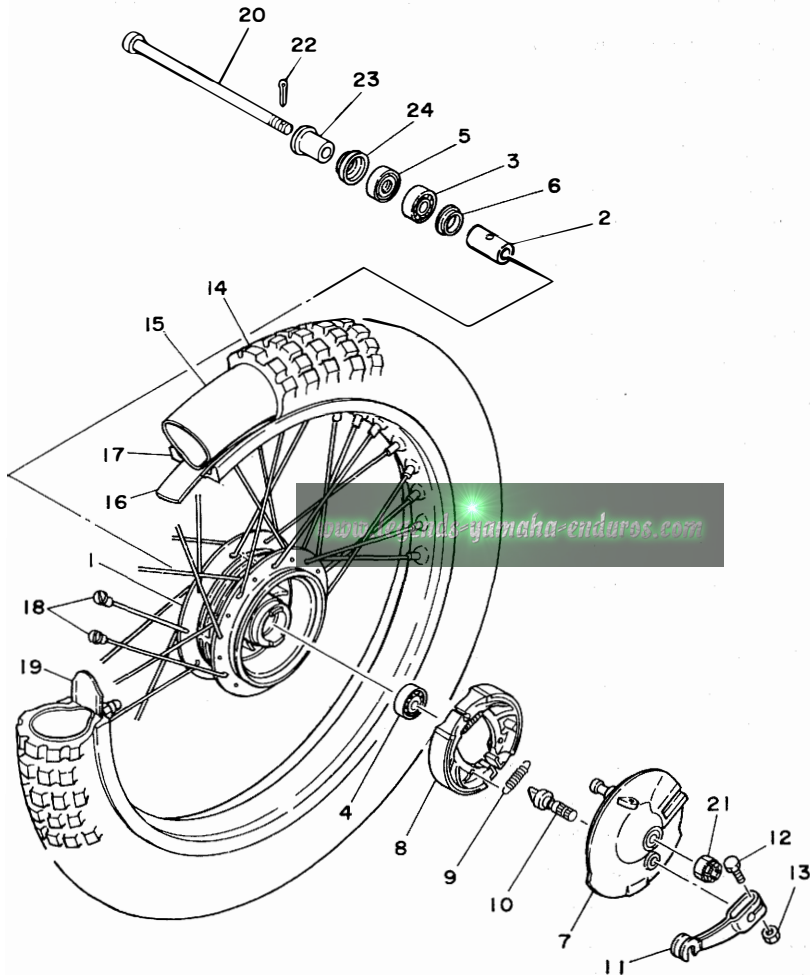
FIG. 24 SEAT

REF. NO.	PART NO.	DESCRIPTION	Q'TY	REMARKS
1	5X2-24770-10	SEMI-DOUBLE SEAT ASSY	1	
2	5X2-24771-10	•COVER, semi-double seat	1	



C15

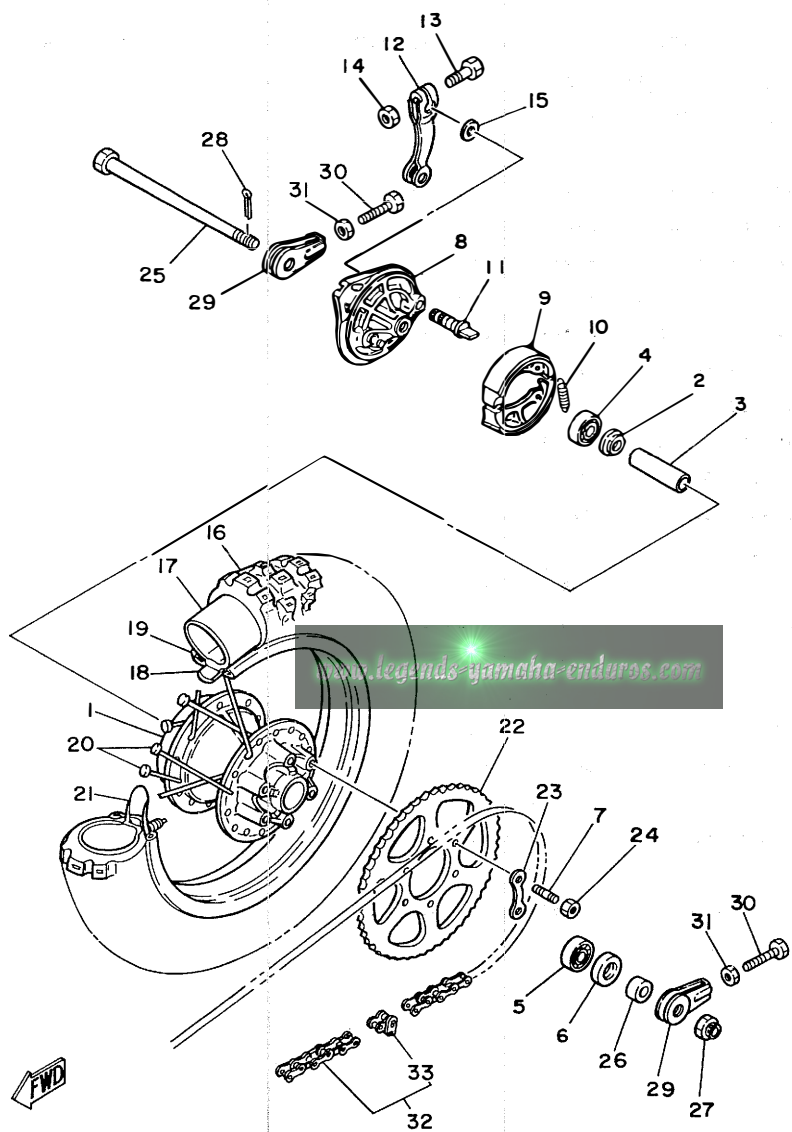
FIG. 25 FRONT WHEEL



REF. NO.	PART NO.	DESCRIPTION	Q'TY	REMARKS
1	462-25111-01-98	HUB, front	1	low gloss black
2	90560-12138	SPACER	1	
3	93306-00105	BEARING (B6001)	1	
4	93306-00104	BEARING (B6001RS)	1	
5	93106-18013	OIL SEAL	1	
6	462-25115-00	FLANGE, sPacer 1	1	
7	2J5-25121-00-98	PLATE, brake shoe	1	low gloss black
8	5X2-25130-00	BRAKE SHOE COMP.	2	
9	90506-14081	SPRING, tension	2	
10	451-25151-00	CAMSHAFT	1	
11	451-25155-00	LEVER, camshaft 1	1	
12	90101-06291	BOLT	1	
13	95301-06600	NUT	1	
14	94127-17723	TIRE (2.75-17)	1	
15	94227-17152	TUBE (2.75-17)	1	
16	94327-17103	BAND, rim (2.75-17)	1	
17	94414-17303	RIM (1.40-17)	1	
18	4V1-25104-00	SPOKE SET, front	1	
19	1T1-25194-00	SPACER, bead	1	
20	90102-12015	BOLT, with hole	1	
21	90171-12005	NUT, castle	1	
22	91401-30025	PIN, cotter	1	
23	2J5-25183-00	COLLAR, wheel	1	
24	462-25118-00	COVER, hub dust	1	

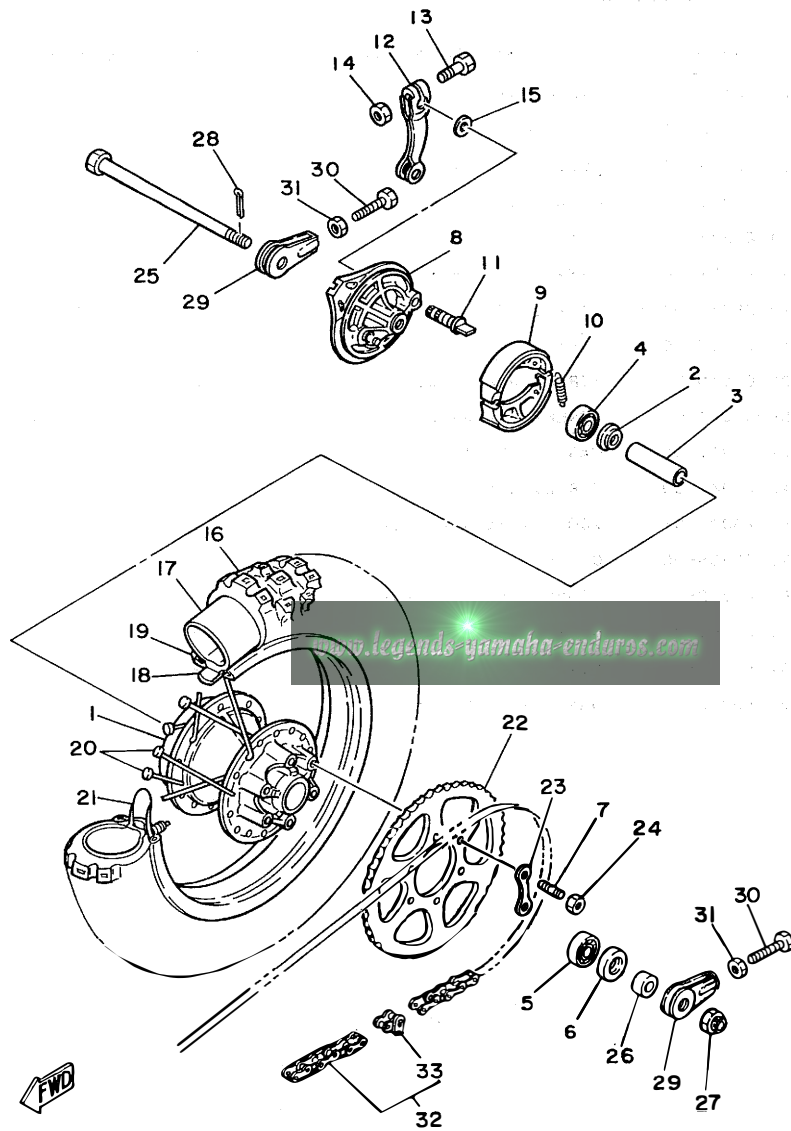


FIG. 26 REAR WHEEL



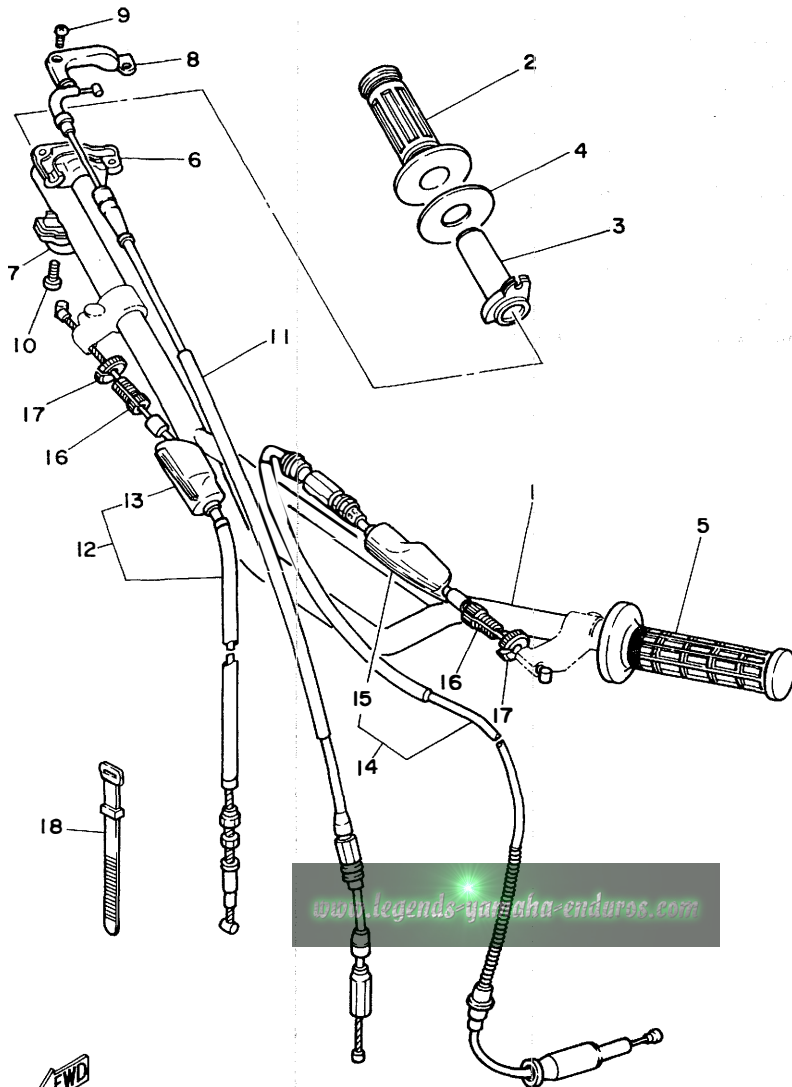
REF. NO.	PART NO.	DESCRIPTION	Q'TY	REMARKS
1	5X2-25311-00-98	HUB, rear	1	low gloss black
2	183-25315-00	FLANGE, spacer	1	
3	5X2-25317-00	SPACER, bearing	1	
4	93306-30203	BEARING (B6302Z)	1	
5	93306-30205	BEARING	1	UR
	93306-30208	BEARING	1	UR
6	93106-26005	OIL SEAL	1	
7	90116-08283	BOLT, stud	6	
8	5X2-25321-00-98	PLATE, brake shoe	1	low gloss black
9	451-25130-00	BRAKE SHOE COMP.	2	
10	90506-14081	SPRING, tension	2	
11	3R0-25351-00	CAMSHAFT	1	
12	3R0-25355-11	LEVER, camshaft	1	
13	90101-06278	BOLT	1	
14	95301-06600	NUT	1	
15	90201-12166	WASHER, plate	1	
16	94141-14724	TIRE (4.10-14)	1	
17	94241-14175	TUBE (4.10-14)	1	
18	94336-14102	BAND, rim (3.60-14)	1	
19	94416-14273	RIM (1.60-14)	1	
20	4V1-25304-00	SPDKE SET, rear	1	
21	2J5-25394-00	SPACER, bead	1	
22	4V1-25444-10-33	SPROCKET, driven (44T)	1	STD yamaha black
	4V1-25442-10-33	SPROCKET, driven (42T)	1	UR yamaha black
	4V1-25446-10-33	SPROCKET, driven (46T)	1	UR yamaha black
23	214-25412-00	WASHER	3	
24	90170-08158	NUT	6	
25	5X2-25381-00	AXLE, wheel	1	

FIG. 26 REAR WHEEL



REF. NO.	PART NO.	DESCRIPTION	Q'TY	REMARKS
26	90387-15115	COLLAR	1	
27	90171-14020	NUT, castle	1	
28	91401-30030	PIN, cotter	1	
29	248-25388-00	PULLER, chain 1	2	
30	90101-08034	BOLT	2	
31	95301-08700	NUT	2	
32	94580-24110	CHAIN	1	
33	94680-24001	JOINT, chain	1	

FIG. 27 HANDLEBAR.CABLE

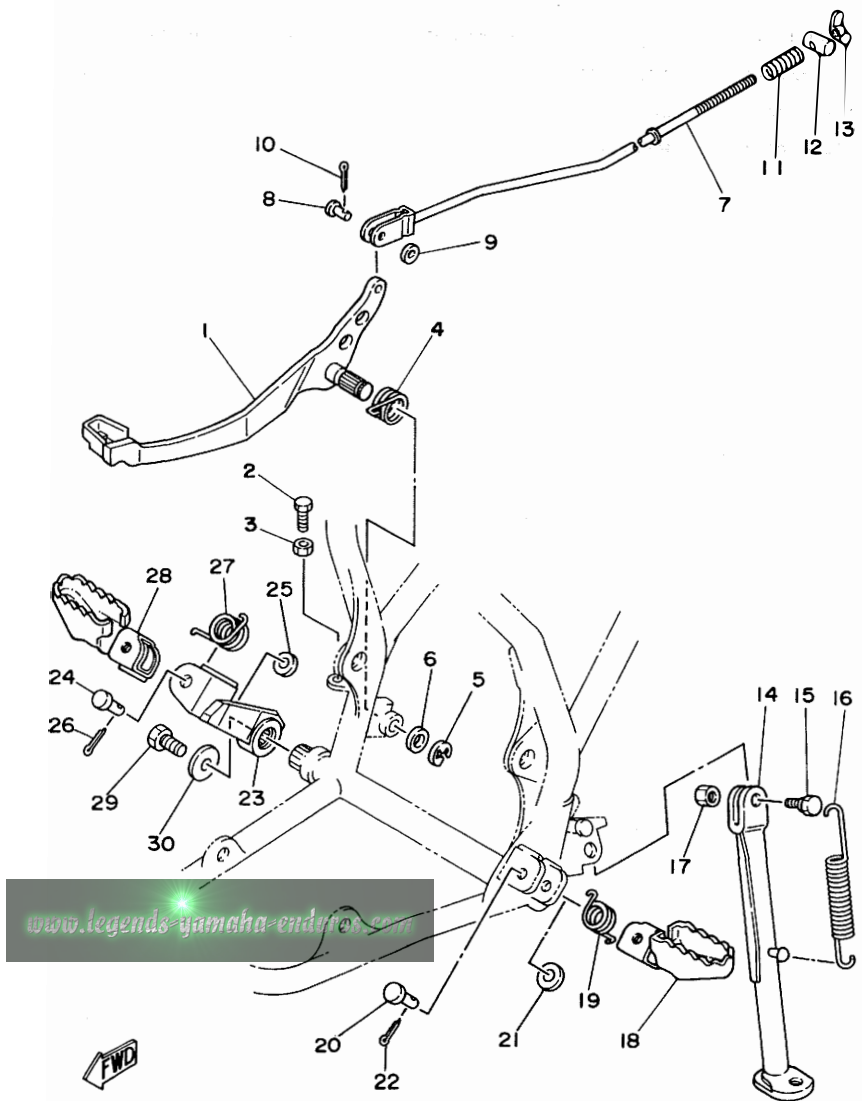


REF. NO.	PART NO.	DESCRIPTION	Q'TY	REMARKS
1	5X2-26111-00	HANDLEBAR	1	
2	3R9-26242-00	GRIP (R.H)	1	
3	322-26243-00	TUBE, throttle guide	1	
4	1W1-26249-00	RING, leaf	1	
5	4V4-26241-00	GRIP (L.H)	1	
6	5X2-26281-00	CAP, grip upper	1	
7	322-26282-00-98	CAP, grip lower	1	low gloss black
8	5X2-2628H-00	CAP, wire	1	
9	98606-04012	SCREW, oval head	2	
10	98506-05016	SCREW, Pan head	2	
11	5X2-26311-00	CABLE, throttle 1	1	
12	5X2-26341-00	CABLE, brake	1	
13	382-26372-01	.COVER, handle lever 1	1	
14	5X2-26335-00	CABLE, clutch	1	
15	382-26372-01	.COVER, handle lever 1	1	
16	90123-08013	BOLT	2	
17	90179-08148	NUT	2	
18	437-83936-10	BAND, switch cord	1	



D5

FIG. 28 STAND.FOOTREST

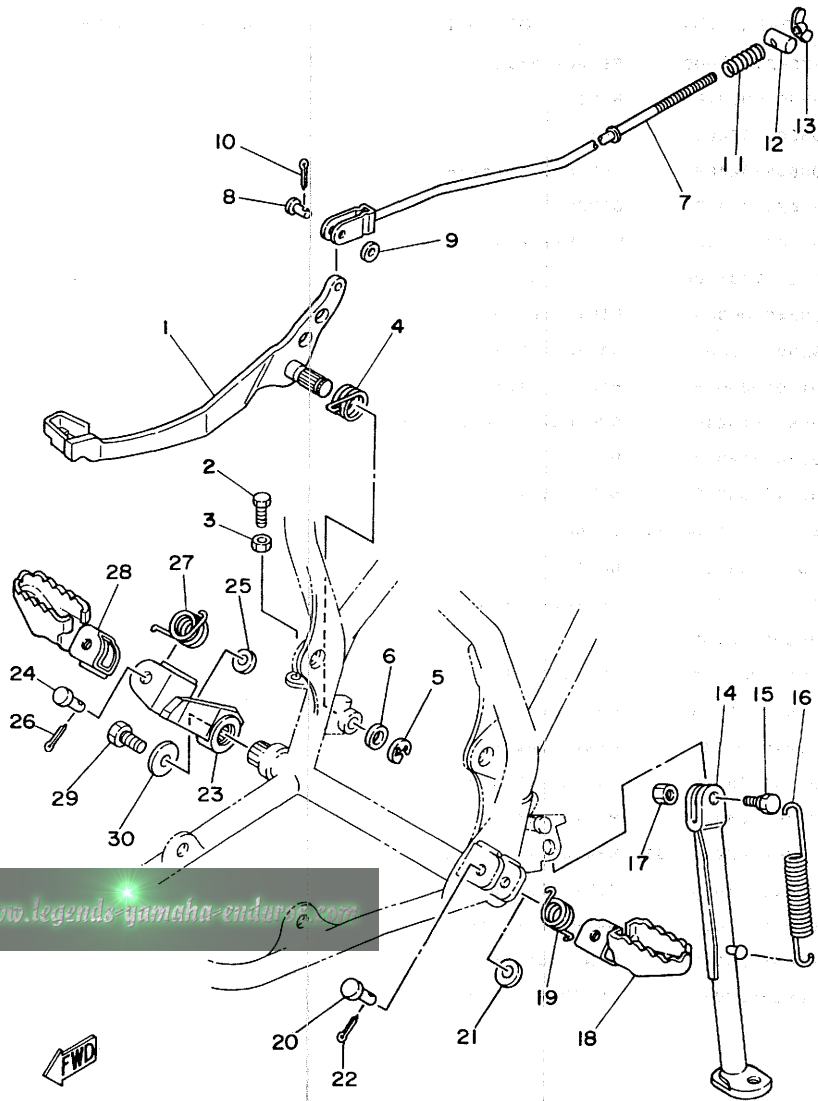


REF. NO.	PART NO.	DESCRIPTION	Q'TY	REMARKS
1	5X2-27211-00	PEDAL, brake	1	
2	97301-06016	BOLT	1	
3	95301-06600	NUT	1	
4	90508-32468	SPRING, torsion	1	
5	93430-09019	CIRCLIP	1	
6	92902-12600	WASHER, Plate	1	
7	5X2-27231-00	ROD, brake	1	
8	90240-06040	PIN, clevis	1	
9	92901-06200	WASHER, Plain	1	
10	91401-20015	PIN, cotter	1	
11	90501-10245	SPRING, compression	1	
12	90249-12008	PIN	1	
13	90175-06013	NUT, wing	1	
14	4V1-27311-00-R4	STAND, side	1	black
15	90109-08063	BOLT	1	
16	90506-26270	SPRING, tension	1	
17	95301-08700	NUT	1	
18	3R1-27411-00	FOOTREST 1	1	uni chrome (black)
19	90508-20023	SPRING, torsion	1	
20	90240-08085	PIN, clevis	1	
21	92901-08600	WASHER, Plate	1	
22	91401-25015	PIN, cotter	1	
23	5X2-27422-00-33	BRACKET, footrest 2	1	yamaha black
24	90240-08085	PIN, clevis	1	
25	92901-08600	WASHER, Plate	1	
26	91401-25015	PIN, cotter	1	
27	90508-20023	SPRING, torsion	1	

D6

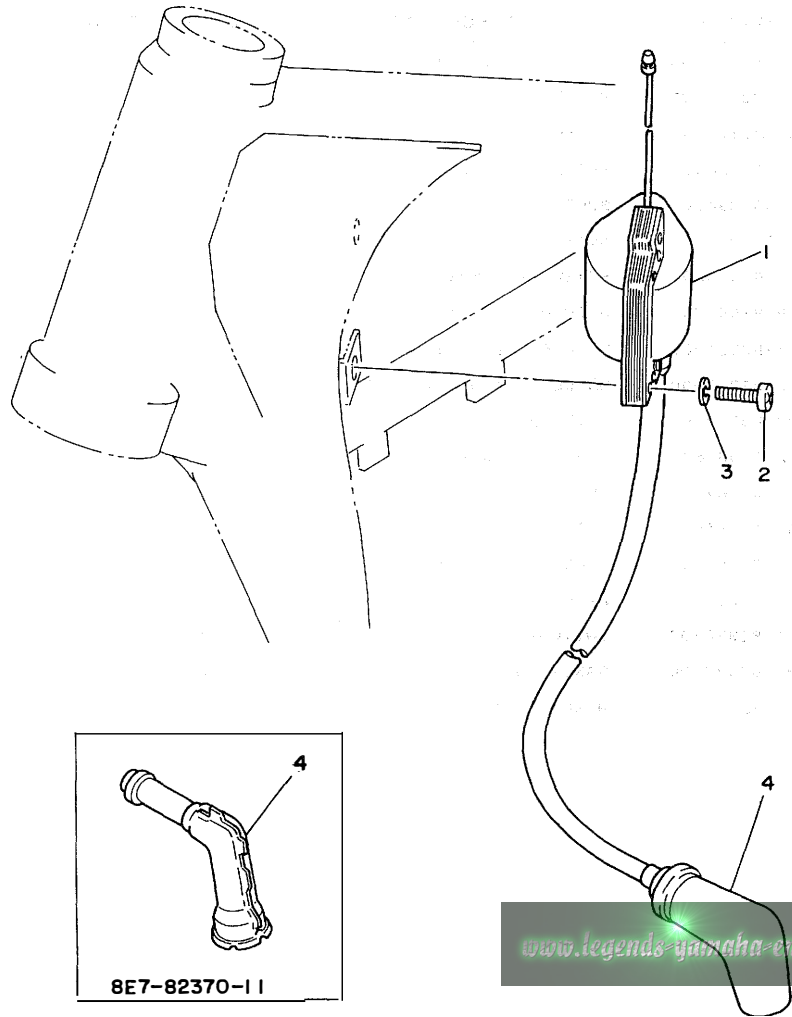
FIG. 28 STAND.FOOTREST

REF. NO.	PART NO.	DESCRIPTION	Q'TY	REMARKS
28	3R1-27421-00	FOOTREST 2	1	uni chrome (black)
29	97311-10016	BOLT	1	
30	90201-10144	WASHER, Plate	1	



D7

FIG. 29 ELECTRICAL 1



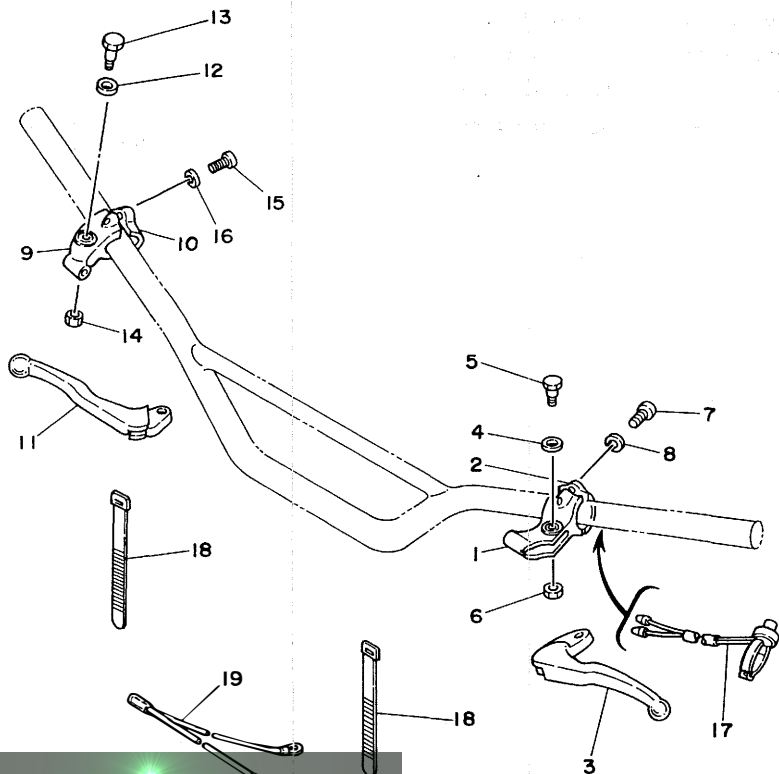
REF. NO.	PART NO.	DESCRIPTION	Q'TY	REMARKS
1	2K7-82310-10	IGNITION COIL ASSY	1	
2	92501-06025	SCREW, Pan head	2	
3	92901-06100	WASHER, sPring	2	
4	3R0-82370-20	PLUG CAP ASSY	1	UR
	8E7-82370-11	PLUG CAP ASSY	1	UR with noise suPPressor



D8

FIG. 30 HANDLE SWITCH-LEVER

REF. NO.	PART NO.	DESCRIPTION	Q'TY	REMARKS
1	4V4-82911-00	HOLDER, lever 1	1	
2	4V4-82913-00	HOLDER, lever lower 1	1	
3	3M2-83912-00	LEVER 1	1	
4	90201-08083	WASHER, Plate	1	
5	90109-06410	BOLT	1	
6	95601-06100	NUT, u	1	
7	98506-05020	SCREW, Pan head	2	
8	92906-05100	WASHER, sPring	2	
9	4V4-82921-00	HOLDER, lever 2	1	
10	4V4-82913-00	HOLDER, lever lower 1	1	
11	3M2-83922-00	LEVER 2	1	
12	90201-08083	WASHER, Plate	1	
13	90109-06410	BOLT	1	
14	95601-06100	NUT, u	1	
15	98506-05020	SCREW, Pan head	2	
16	92906-05100	WASHER, sPring	2	
17	4V1-83976-00	SWITCH, handle 1	1	
18	437-83936-00	BAND, switch cord	2	
19	4V0-82519-00	WIRE, earth lead	1	



www.legends-yamaha-enduros.com

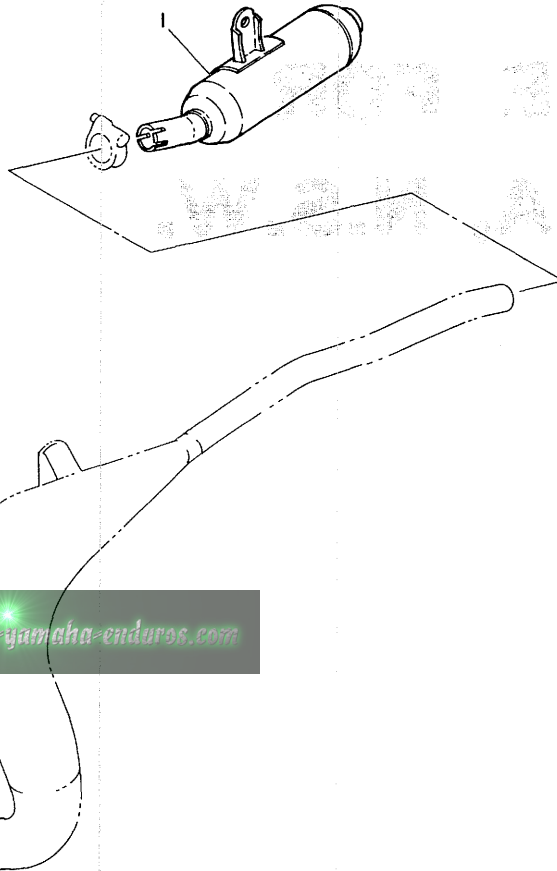


D9

**EXCLUSIVE FOR
AUSTRALIA, N.S.W.**

FIG. 31 ALTERNATE (ENGINE)

REF. NO.	PART NO.	DESCRIPTION	Q'TY	REMARKS
1	4V1-14753-00	SILENCER, exhaust	1	



www.legends-yamaha-enduros.com



D10

REPAIR KIT

www.legends-yamaha-enduros.com

134

FIG. 32 REPAIR KIT

REF. NO.	PART NO.	DESCRIPTION	Q'TY	REMARKS
1	5X2-11630-00	PISTON ASSY (STD)	1	
2	5X2-11631-00-94	•PISTON (STD)	1	
3	5X2-11601-00	•PISTON RING SET (STD)	1	
4	4V1-11633-00	•PIN, Piston	1	
5	5X2-11634-00	•CLIP, Piston Pin	2	
6	5X2-11630-10	PISTON ASSY (1ST O/S)	1	
7	5X2-11635-00	•PISTON (1ST O/S 0.25MM)	1	
8	5X2-11601-10	•PISTON RING SET (1ST O/S)	1	
9	4V1-11633-00	•PIN, Piston	1	
10	5X2-11634-00	•CLIP, Piston Pin	2	
11	5X2-11630-20	PISTON ASSY (2ND O/S)	1	
12	5X2-11636-00	•PISTON (2ND O/S 0.50MM)	1	
13	5X2-11601-20	•PISTON RING SET (2ND O/S)	1	
14	4V1-11633-00	•PIN, Piston	1	
15	5X2-11634-00	•CLIP, Piston Pin	2	
16	5X2-11630-30	PISTON ASSY (3RD O/S)	1	
17	5X2-11637-00	•PISTON (3RD O/S 0.75MM)	1	
18	5X2-11601-30	•PISTON RING SET (3RD O/S)	1	
19	4V1-11633-00	•PIN, Piston	1	
20	5X2-11634-00	•CLIP, Piston Pin	2	
21	5X2-11630-40	PISTON ASSY (4TH O/S)	1	
22	5X2-11638-00	•PISTON (4TH O/S 1.00MM)	1	
23	5X2-11601-40	•PISTON RING SET (4TH O/S)	1	
24	4V1-11633-00	•PIN, Piston	1	
25	5X2-11634-00	•CLIP, Piston Pin	2	
26	5X2-11650-00	CONNECTING ROD ASSY	1	
27	5X2-11651-00	•ROD, connectin	1	



FIG. 32 REPAIR KIT

REF. NO.	PART NO.	DESCRIPTION	Q'TY	REMARKS
28	93310-418U1	•BEARING, cylindrical	1	
29	4V0-11681-00	•PIN, crank 1	1	
30	90209-18112	•WASHER	2	
31	93310-212H4	•BEARING, cylindrical	1	
32	5X2-W0001-00	GASKET KIT	1	
33	93211-13109	•O-RING	1	
34	93210-62323	•O-RING	1	
35	4V0-11351-00	•GASKET, cylinder	1	
36	311-13621-01	•GASKET, valve seat	1	
37	152-14613-00	•GASKET, exhaust pipe	1	
38	90430-12038	•GASKET	1	
39	93210-14104	•O-RING	1	
40	4V0-15451-02	•GASKET, crankcase cover	1	
41	5X2-15462-00	•GASKET, crankcase cover 3	1	



INDEX

NUMERICAL INDEX

PART NO.	REF. NO.	PART NO.	REF. NO.	PART NO.	REF. NO.
3R0-25351-00	26-11	5X2-85510-10	3- 3	90201-08085	4- 9
3R0-25355-11	26-12	5X2-85520-10	3- 4	90201-08730	17-11
5X2-25381-00	26-25	5X2-85540-10	3-16	90201-08753	16- 9
248-25388-00	26-29	3R1-85546-00	3-17	90201-10144	28-30
2J5-25394-00	26-21	5X2-85550-10	3- 2	90201-10614	4- 6
214-25412-00	26-23	2K7-85555-00	16-14	90201-12166	26-15
4V1-25442-10-33	26-22	90101-06278	26-13	90201-12631	11-15
4V1-25444-10-33	26-22	90101-06291	25-12	90201-14411	12-23
4V1-25446-10-33	26-22	90101-08034	26-30	90201-15441	11- 4
5X2-26111-00	27- 1	90102-12015	25-20	90201-237E8	21-13
4V4-26241-00	27- 5	90105-08024	16- 3	90202-06010	8- 4
3R9-26242-00	27- 2	90105-08189	16- 4		23-22
322-26243-00	27- 3	90109-06001	14-10	90208-12015	12- 4
1M1-26249-00	27- 4	90109-06410	30- 5		12-16
5X2-2628H-00	27- 8		30-13	90209-06187	17- 3
5X2-26281-00	27- 6	90109-08063	28-15	90209-18112	2- 7
322-26282-00-98	27- 7	90116-08166	8- 6		32-30
5X2-26311-00	27-11	90116-08283	26- 7	90240-06040	28- 8
5X2-26335-00	27-14	90116-08368	1- 7	90240-08085	28-20
5X2-26341-00	27-12	90123-08013	27-16		28-24
382-26372-01	27-13	90149-06011	23-23	90240-10064	20-22
	27-15	90170-08158	26-24	90240-10073	20-23
5X2-27211-00	28- 1	90170-12060	12-17	90249-12008	28-12
5X2-27231-00	28- 7	90170-20213	20-17	90250-06013	14-14
4V1-27311-00-R4	28-14	90171-12005	25-21	90280-03017	2-13
3R1-27411-00	28-18	90171-14020	26-27	90282-04036	14- 5
3R1-27421-00	28-28	90175-06013	28-13	90282-05001	12- 3
5X2-27422-00-33	28-23	90179-08148	27-17	90338-07011	9- 8
2X6-28100-10	16-12	90179-08358	1- 8	90339-11001	16- 2
1M1-28137-00	16-13	90179-10257	3-15	90340-12059	9-11
109-81328-11	3- 8	90179-10272	11-18	90381-08002	4- 5
2T4-82131-00	6-26	90179-12335	12- 5	90386-18099	19- 6
2K7-82310-10	29- 1	90179-22330	21-14	90386-18109	19- 7
3R0-82370-20	29- 4	90179-25033	21-12	90387-072E7	5-20
8E7-82370-11	29- 4	90185-08089	16- 6	90387-07598	23- 6
4V0-82519-00	30-19	90201-05775	12-15	90387-121F6	19- 8
4V4-82911-00	30- 1	90201-06067	6-21	90387-121F7	19- 9
4V4-82913-00	30- 2	90201-06072	23- 7	90387-15115	26-26
	30-10	90201-06073	5-14	90387-20163	12- 2
	30- 9	90201-06557	5-18	90430-06016	10-11
4V4-82921-00	30- 9		17- 2	90430-06166	1-11
3M2-83912-00	30- 3		17-10		4-13
3M2-83922-00	30-11		18- 6	90430-12038	9-12
437-83936-00	3-19		18-11		32-38
	30-18		21-29	90430-12174	1- 9
437-83936-10	3-18		14- 9	90445-08376	9- 5
	27-18	90201-06655	30- 4	90445-09104	23-17
4V1-83976-00	30-17	90201-08083	30-12	90445-11149	23-24
5X2-85500-10	3- 1				

NUMERICAL INDEX

PART NO.	REF. NO.	PART NO.	REF. NO.	PART NO.	REF. NO.
90445-15612	6-24	92506-06008	10-10	92902-06100	20-30
90446-09184	5- 3	92506-06016	4-16	92902-06600	20-31
90460-16192	5- 8		5-10	92902-08100	22-25
90460-43053	6- 9	92506-06025	10- 7	92902-12600	28- 8
90460-51059	6-10	92506-06030	10- 3	92906-05100	30- 6
90462-14055	21- 3	92506-06035	9- 3		30-16
90467-09006	5- 4	92506-06045	9- 2	93102-20143	13-23
90467-10008	23-25	92506-06060	4-15	93102-20231	2-15
90467-16063	6-25	92701-06012	13- 8	93102-28257	21-36
90468-26046	11- 3	92901-04100	3-10	93102-29256	21-35
90480-13197	6-18	92901-04600	3-11	93103-12119	4- 4
90480-15064	5-19	92901-05100	3- 6	93103-28126	2-16
		92901-05600	3- 7	93106-18013	25- 5
		92901-06100	3-13	93106-26005	26- 6
90480-17213	20-32		5-15	93109-12012	15- 5
90480-18290	23- 4		6-20	93109-14021	12-22
90501-10245	28-11		8-11	93109-15001	11- 7
90501-12081	11-14		18- 5	93109-18020	19-10
90501-20125	12-12		18-10	93210-14104	10- 9
90506-14081	25- 9		19-16		32-39
	26-10		21- 5	93210-16275	5-12
90506-26270	28-16		21-28	93210-18288	7- 9
90508-18463	12-24		21-33	93210-19026	5-11
90508-20023	28-19		23- 4	93210-21276	21-31
	28-27		23- 9	93210-23505	21-15
90508-26462	14- 8		23-12	93210-60538	1- 3
90508-26464	11- 5		23-28	93210-62323	32-34
90508-32465	15- 3		29- 3	93211-13109	1- 2
90508-32468	28- 4	92901-06200	28- 9		32-33
90560-12138	25- 2	92901-06600	3-14	93306-00104	25- 4
91401-20015	28-10		6- 8	93306-00105	4- 3
91401-25015	28-22		6-17		25- 3
	28-26		8-12	93306-00422	14- 4
91401-25020	20-25		21-34	93306-20303	13-19
91401-30025	25-22		8- 7	93306-20401	13-22
91401-30030	26-28	92901-08100	16-10	93306-20438	2-14
91830-21014	10- 6		17-15	93306-30203	26- 4
91830-22016	9- 6		21-19	93306-30205	26- 5
92501-06010	9-10		16- 5	93306-30208	26- 5
92501-06012	20-29	92901-08200	21-18	93310-212H4	2-12
	21- 5	92901-08600	28-21		32-31
	23-27		28-25	93310-418U1	2- 5
92501-06015	6-16		20-24		32-28
	18- 4	92901-10600	19- 5	93311-31249	13-20
	18- 9	92901-12100	7-18	93315-21429	12-21
	21-27	92902-04100	21-39	93315-31502	13-21
92501-06020	3-12	92902-05200	17- 5	93410-12003	11-10
92501-06025	29- 2	92902-06100	17- 9	93410-18062	13-25
92502-06016	17- 8				

NUMERICAL INDEX

PART NO.	REF. NO.	PART NO.	REF. NO.	PART NO.	REF. NO.
93410-20038	13-16	97301-06020	21-32		
93430-07012	4- 8	97301-06025	6- 7		
93430-08007	11-16	97301-06030	5-17		
93430-09019	28- 5	97301-06045	19-15		
93430-10016	15- 2	97301-08020	17-12		
93440-15012	13-18	97301-08022	17-13		
93440-16089	13- 6	97301-08050	21-17		
93440-42101	20-21	97302-06020	17- 4		
93501-04011	21- 7	97311-10016	28-29		
93503-16010	12-20	97321-06020	15- 8		
	21-10	97321-06030	23- 8		
93507-32009	11-13	97321-08040	22-26		
93603-22028	4- 7	97602-03108	6- 4		
93604-10011	4-12	97702-50512	21-40		
93604-26132	20-14	98501-04005	20- 4		
93608-30128	15- 4	98501-04008	3- 9		
94127-17723	25-14	98501-04016	7-17		
94141-14724	26-16	98501-05030	3- 5		
94227-17152	25-15	98506-05016	27-10		
94241-14175	26-17	98506-05020	30- 7		
94327-17103	25-16		30-15		
94336-14102	26-18	98606-04012	27- 9		
94414-17303	25-17	98701-05016	14- 6		
94416-14273	26-19	98701-05020	12-13		
94580-24110	26-32	98902-06014	23-14		
94680-24001	26-33	98903-06008	8- 3		
*	1- 4				
95301-06600	5-16				
	25-13				
	26-14				
	28- 3				
95301-08600	8- 8				
	16- 8				
95301-08700	26-31				
	28-17				
95301-08800	17-14				
	21-20				
95311-12700	19- 4				
95601-06100	30- 6				
	30-14				
95821-08035	21-24				
95826-06010	1-10				
95826-06020	4-14				
97301-06010	23-11				
97301-06012	6-19				
	23- 3				
97301-06016	8-10				
	28- 2				

PARTS NAME INDEX

DESCRIPTION	REF. NO.
AIR CLEANER CASE ASSY	6-11
AIR VALVE COMP.	22-20
AXLE, drive	13- 9
AXLE, main	13- 1
AXLE, wheel	26-25
BALL	11-13
*	12-20
*	21- 7
*	21-10
BAND	3-17
BAND, battery	6-26
BAND, rim (2.75-17)	25-16
BAND, rim (3.60-14)	26-18
BAND, silencer	8-13
BAND, switch cord	3-18
*	3-19
*	27-18
*	30-18
BAND, tank fitting 1	23-13
BAR, shift fork guide 1	14-15
BAR, shift fork guide 2	14-16
BEARING	2-14
*	14- 4
*	26- 5
*	26- 5
BEARING (B6001)	4- 3
*	25- 3
BEARING (B6001RS)	25- 4
BEARING (B6203Z)	13-19
BEARING (B6204)	13-22
BEARING (B6302Z)	26- 4
BEARING, cylindrical	2- 5
*	2-12
*	12-21
*	13-20
*	13-21
*	32-28
*	32-31
BODY, caP	23-15
BODY, float chamber 1	7- 3
BOLT	5-17
*	6- 7
*	6-19
*	8-10
*	14-10
*	15- 8
*	17- 4

PARTS NAME INDEX

DESCRIPTION	REF. NO.
BOLT	17-12
*	17-13
*	19-15
*	21-17
*	21-32
*	22-26
*	23- 3
*	23- 8
*	23-11
*	25-12
*	26-13
*	26-30
*	27-16
*	28- 2
*	28-15
*	28-29
*	30- 5
*	30-13
BOLT, caP	22-22
BOLT, flange	1-10
*	4-14
*	21-24
BOLT, hexagon socket head	22-18
BOLT, stud	1- 7
*	8- 6
*	26- 7
BOLT, washer based	16- 3
*	16- 4
BOLT, with hole	25-20
BOSS, clutch	12- 8
BOSS, kick crank	11-12
BRACKET, footrest 2	28-23
BRACKET, seat	23-26
BRAKE SHOE COMP.	25- 8
*	26- 9
BUMP, stop	20- 9
BUSH	19- 6
*	19- 7
BUSH, rear shock absorber	20- 3
*	20-12
BUSH, solid	4- 5
C.D.I. MAGNETO ASSY	3- 1
C.D.I. UNIT ASSY	3-16
CABLE, brake	27-12
CABLE, clutch	27-14
CABLE, throttle 1	27-11
CAMSHAFT	25-10
*	26-11

PARTS NAME INDEX

DESCRIPTION	REF. NO.
CAP	7-23
CAP, air valve	22-19
CAP, case	20- 8
CAP, cleaner case 1	6-14
CAP, grip lower	27- 7
CAP, grip upper	27- 6
CAP, radiator	5- 2
CAP, wire	27- 8
CARBURETOR ASSY	7- 1
CHAIN	26-32
CHAMBER, air	6-22
CIRCLIP	4- 8
*	11-10
*	11-16
*	13- 6
*	13-16
*	13-18
*	13-25
*	15- 2
*	20-21
*	28- 5
CLAMP	3- 8
*	21- 3
CLAMP, hose	5- 8
*	6- 9
*	6-10
CLIP	5- 4
*	6-25
*	7-19
*	7-30
*	11- 3
*	23-25
CLIP, oil seal	22-10
CLIP, Piston Pin	2-11
*	32- 5
*	32-10
*	32-15
*	32-20
*	32-25
CLUTCH ASSY	12- 6
COIL, charge	3- 4
COLLAR	5-20
*	12- 2
*	19- 8
*	19- 9
*	23- 6
*	26-26
COLLAR, wheel	25-23
CONNECTING ROD ASSY	32-26

PARTS NAME INDEX

DESCRIPTION	REF. NO.
CONNECTOR, suction PiPe	9- 4
COVER	20-15
COVER, ball race 2	21-11
COVER, crankcase 1	10- 1
COVER, crankcase 2	10- 4
COVER, handle lever 1	27-13
*	27-15
COVER, housing	4-10
COVER, hub dust	25-24
COVER, kick lever	11-17
COVER, semi-double seat	24- 2
COVER, shift Pedal	15- 7
COVER, side 1	18- 1
COVER, side 2	18- 7
COVER, thrust 2	20-26
CRANK 1	2- 2
CRANK 2	2- 3
CRANKCASE 1	9- 1
CRANKCASE 2	9- 7
CRANKSHAFT ASSY	2- 1
CROWN, handle	21-16
CYLINDER 1	1- 5
DAMPER	21-37
DAMPER, locating 1	18- 2
DAMPER, locating 3	23-29
DAMPER, sub tank	20-27
DUMPER SUB ASSY	20- 2
ELEMENT, air cleaner	6-12
EMBLEM	6-23
EMBLEM 1	18- 3
*	18- 8
EMBLEM 5	21-26
EMBLEM, rear arm	19- 2
EXHAUST PIPE ASSY 1	8- 1
FENDER, front	17- 1
FENDER, rear	17- 6
FLANGE, sPacer	26- 2
FLANGE, sPacer 1	25- 6
FLAP	17- 7
FLOAT	7-13
FOOTREST 1	28-18
FOOTREST 2	28-28
FORK UNIT ASSY	22- 3
FORK UNIT ASSY 2	22- 2
FORK, shift 1	14-11
FORK, shift 2	14-12
FORK, shift 3	14-13
FRAME COMP	16- 1

PARTS NAME INDEX

DESCRIPTION	REF. NO.
FRONT FORK ASSY	22- 1
FUEL COCK ASSY 1	23-18
FUEL TANK COMP.	23- 1
GASKET	1- 9
*	1-11
*	4-13
*	7-22
*	7-28
*	9-12
*	10-11
*	22-23
*	23-19
*	32-38
GASKET KIT	32-32
GASKET, caP	23-16
GASKET, crankcase cover	10- 2
*	32-40
GASKET, crankcase cover 3	10- 5
*	32-41
GASKET, cylinder	1- 6
*	32-35
GASKET, exhaust PiPe	8- 5
*	32-37
GASKET, float chamber	7- 2
GASKET, housing cover 2	4-11
GASKET, valve seat	6- 5
*	32-36
GEAR, imPeller shaft	4- 1
GEAR, kick (24T)	11- 2
GEAR, Primary drive	12- 1
GEAR, sProcket idle (25T)	11- 8
GEAR, 1st wheel (36T)	13-15
GEAR, 2nd Pinion (16T)	13- 5
GEAR, 2nd wheel (33T)	13-10
GEAR, 3rd wheel (31T)	13-12
GEAR, 3rd/4th Pinion (19T,21T)	13- 3
GEAR, 4th wheel (28T)	13-13
GEAR, 5th Pinion (20T)	13- 2
GEAR, 5th wheel	13-14
GEAR, 6th Pinion	13- 4
GEAR, 6th wheel	13-11
GRAPHIC SET	23-30
GRIP (L+H)	27- 5
GRIP (R+H)	27- 2
GROMMET	5-19
*	6-18
*	20-32
*	23- 5

PARTS NAME INDEX

DESCRIPTION	REF. NO.
GUIDE	6-13
GUIDE, cable	7-21
GUIDE, sPring	11- 6
GUIDE, sPring 1	20-19
HANDLEBAR	27- 1
HEAD, cylinder 1	1- 1
HOLDER, cable	22-27
HOLDER, cable 1	21-21
HOLDER, handle uPPer	21-23
HOLDER, lever lower 1	30- 2
*	30-10
HOLDER, lever 1	30- 1
HOLDER, lever 2	30- 9
HOLDER, sub tank	20-28
HOSE	5- 3
*	6-24
*	9- 5
*	23-17
*	23-24
HUB, front	25- 1
HUB, rear	26- 1
IGNITION COIL ASSY	29- 1
IMPELLER SHAFT ASSY	4- 2
INNER TUBE COMP.1	22-11
JET, main (#200)	7-12
JET, main (#210)	7-12
JET, main (#220)	7-12
JET, Pilot (#35.0)	7- 4
JOINT	5- 9
*	21-30
JOINT, carburetor	6- 6
JOINT, chain	26-33
KEY, straight	12- 3
*	14- 5
KEY, woodruff	2-13
KICK AXLE ASSY	11- 1
KICK CRANK ASSY	11-11
LEVER 1	30- 3
LEVER 2	30-11
LEVER, camshaft	26-12
LEVER, camshaft 1	25-11
LEVER, stopPer	14- 7
METAL, slide 2	22- 4
NEEDLE	7- 8
NEEDLE VALVE ASSY	7- 6
NOZZLE, main	7-11
NUT	1- 8

PARTS NAME INDEX

DESCRIPTION	REF. NO.
NUT	3-15
*	5-16
*	8- 8
*	11-18
*	12- 5
*	12-17
*	16- 8
*	19- 4
*	20-17
*	21-12
*	21-14
*	25-13
*	26-14
*	26-24
*	26-31
*	27-17
*	28- 3
*	28-17
NUT, adjusting	20-13
NUT, cable adjusting	7-20
NUT, castle	25-21
*	26-27
NUT, crown	17-14
*	21-20
NUT, self-locking	16- 6
NUT, u	30- 6
*	30-14
NUT, wing	28-13
O-RING	1- 2
*	1- 3
*	5-11
*	5-12
*	7- 9
*	7-32
*	7-34
*	10- 9
*	21-15
*	21-31
*	22- 5
*	22-21
*	23-20
*	32-33
*	32-34
*	32-39
OIL SEAL	2-15
*	2-16
*	4- 4
*	11- 7

PARTS NAME INDEX

DESCRIPTION	REF. NO.
OIL SEAL	12-22
*	13-23
*	15- 5
*	19-10
*	21-35
*	21-36
*	22- 6
*	25- 5
*	26- 6
PEDAL, brake	28- 1
PEDAL, shift	15- 6
PIN	28-12
PIN, clevis	20-22
*	20-23
*	28- 8
*	28-20
*	28-24
PIN, cotter	20-25
*	25-22
*	26-28
*	28-10
*	28-22
*	28-26
PIN, crank 1	2- 6
*	32-29
PIN, dowel	4- 7
*	4-12
*	9- 6
*	10- 6
*	15- 4
*	20-14
PIN, float	7- 7
PIN, Piston	2- 9
*	32- 4
*	32- 9
*	32-14
*	32-19
*	32-24
PIN, straight	14-14
PIPE	7-16
PIPE 1	5- 5
PIPE 2	5- 6
PIPE 3	5- 7
PISTON (STD)	2- 8
*	2- 8
*	32- 2
PISTON (1ST O/S 0.25MM)	2- 8

PARTS NAME INDEX

DESCRIPTION	REF. NO.
PISTON (1ST O/S 0.25MM)	32- 7
PISTON (2ND O/S 0.50MM)	2- 8
*	32-12
PISTON (3RD O/S 0.75MM)	2- 8
*	32-17
PISTON (4TH O/S 1.00MM)	2- 8
*	32-22
PISTON ASSY (STD)	32- 1
PISTON ASSY (1ST O/S)	32- 6
PISTON ASSY (2ND O/S)	32-11
PISTON ASSY (3RD O/S)	32-16
PISTON ASSY (4TH O/S)	32-21
PISTON RING SET (STD)	2-10
*	32- 3
PISTON RING SET (1ST O/S)	2-10
*	32- 8
PISTON RING SET (2ND O/S)	2-10
*	32-13
PISTON RING SET (3RD O/S)	2-10
*	32-18
PISTON RING SET (4TH O/S)	2-10
*	32-23
PISTON, front fork	22-13
PLATE	9- 9
PLATE, bearing cover	13- 7
PLATE, brake shoe	25- 7
*	26- 8
PLATE, clutch 1	12-10
PLATE, friction	12-11
PLATE, number	21-25
PLATE, Pressure 1	12- 9
PLATE, side 1	14- 3
PLATE, thrust 1	12-14
PLUG	9- 8
*	16- 2
PLUG CAP ASSY	29- 4
*	29- 4
PLUG, drain	22- 8
PLUG, oil	10- 8
PLUG, screw	7-10
PLUG, sPark	1- 4
PLUG, straight screw	9-11
PLUNGER, starter	7-31
PRIMARY DRIVEN GEAR COMP.	12- 7
PROTECTOR	21-38
PROTECTOR, muffler 1	8- 2
PULLER, chain 1	26-29
PULLER, rotor	16-14

PARTS NAME INDEX

DESCRIPTION	REF. NO.
PUSH LEVER ASSY	12-25
RACE, ball 1	21- 1
*	21- 8
RACE, ball 2	21- 6
*	21- 9
RADIATOR ASSY	5- 1
REAR ARM COMP.	19- 1
REED VALVE ASSY	6- 1
REED, valve	6- 2
RIM (1.40-17)	25-17
RIM (1.60-14)	26-19
RING, leaf	27- 4
RING, Piston	22-15
ROD, brake	28- 7
ROD, connecting	2- 4
*	32-27
ROD, Push	20- 5
ROD, Push 1	12-18
ROD, Push 2	12-19
ROTOR ASSY	3- 2
SCREW	23-23
SCREW, air adjusting	7-35
SCREW, bind	8- 3
*	23-14
SCREW, flat head	12-13
*	13- 8
*	14- 6
SCREW, lever fitting	23-21
SCREW, oval head	27- 9
SCREW, Pan head	3- 5
*	3- 9
*	3-12
*	4-15
*	4-16
*	5-10
*	6-16
*	7-17
*	9- 2
*	9- 3
*	9-10
*	10- 3
*	10- 7
*	10-10
*	17- 8
*	18- 4
*	18- 9
*	20- 4
*	20-29

PARTS NAME INDEX

DESCRIPTION	REF. NO.
SCREW, Pan head	21- 4
*	21-27
*	23-27
*	27-10
*	29- 2
*	30- 7
*	30-15
SCREW, Pan head with washer	6- 4
SCREW, tapping	21-40
SCREW, throttle	7-15
SEAL	6-15
SEAL, dust	20- 6
*	22-14
SEAL, Guard	19-12
*	19-13
SEAL, housing	20- 7
SEAL, PiPe 1	5-13
SEAL, steering	16-11
*	21- 2
SEAT, sPring lower	20-20
SEAT, sPring uPPer	20-16
SEGMENT	14- 2
SEMI-DOUBLE SEAT ASSY	24- 1
SHAFT, Pivot	19- 3
SHIFT CAM ASSY	14- 1
SHIFT SHAFT ASSY	15- 1
SHIM	19-11
SHIM 1 (0.6T)	13-17
SHOCK ABSORBER ASSY, rear	20- 1
SILENCER, exhaust	8-14
*	31- 1
SPACER	25- 2
SPACER, bead	25-19
*	26-21
SPACER, bearing	26- 3
SPOKE SET, front	25-18
SPOKE SET, rear	26-20
SPRING	20-18
*	22-12
SPRING SEAT WRENCH	16-13
SPRING, air adjusting	7-33
SPRING, comPression	11-14
*	12-12
*	28-11
SPRING, rebound	22-16
SPRING, tension	25- 9
*	26-10
*	28-16

PARTS NAME INDEX

DESCRIPTION	REF. NO.
SPRING, throttle stoP	7-14
SPRING, throttle valve	7-27
SPRING, torsion	11- 5
*	12-24
*	14- 8
*	15- 3
*	28- 4
*	28-19
*	28-27
SPROCKET, drive (12T)	13-24
SPROCKET, drive (13T)	13-24
SPROCKET, drive (14T)	13-24
SPROCKET, driven (42T)	26-22
SPROCKET, driven (44T)	26-22
SPROCKET, driven (46T)	26-22
STAND, side	28-14
STATOR ASSY	3- 3
STAY	22-28
STAY, chamber	23-10
STAY, fuel tank 1	23- 2
STAY, muffler 1	8- 9
STAY, Plate	21-22
STOPPER, cable	7-26
STOPPER, reed valve	6- 3
SUPPORT, bumP stoP	20-10
SUPPORT, chain	19-14
SWITCH, handle 1	30-17
TAPER, sPindle	22-17
TENSIONER	16- 7
TIRE (2.75-17)	25-14
TIRE (4.10-14)	26-16
TOOL KIT	16-12
TOP, mixing chamber	7-29
TUBE (2.75-17)	25-15
TUBE (4.10-14)	26-17
TUBE, throttle guide	27- 3
UNDER BRACKET COMP.	22-24
UPPER BRACKET SUB ASSY	20-11
VALVE, throttle 1	7-25
WASHER	2- 7
*	17- 3
*	20-31
*	21-39
*	26-23
*	32-30
WASHER 1	11- 9
WASHER, conical sPring	12- 4

PARTS NAME INDEX

DESCRIPTION	REF. NO.
WASHER, conical sPring	12-16
WASHER, main jet	7-24
WASHER, needle valve	7- 5
WASHER, oil seal	22- 7
WASHER, Plain	16- 5
*	28- 9
WASHER, Plate	3- 7
*	3-11
*	3-14
*	4- 6
*	4- 9
*	5-14
*	5-18
*	6- 8
*	6-17
*	6-21
*	8- 4
*	8-12
*	11- 4
*	11-15
*	12-15
*	12-23
*	14- 9
*	16- 9
*	17- 2
*	17-10
*	17-11
*	18- 6
*	18-11
*	20-24
*	21-13
*	21-18
*	21-29
*	21-34
*	23- 7
*	23-22
*	26-15
*	28- 6
*	28-21
*	28-25
*	28-30
*	30- 4
*	30-12
WASHER, sPecial	22- 9
WASHER, sPring	3- 6
*	3-10
*	3-13
*	5-15

PARTS NAME INDEX

DESCRIPTION	REF. NO.
WASHER, sPring	6-20
*	7-18
*	8- 7
*	8-11
*	16-10
*	17- 5
*	17- 9
*	17-15
*	18- 5
*	18-10
*	19- 5
*	19-16
*	20-30
*	21- 5
*	21-19
*	21-28
*	21-33
*	22-25
*	23- 4
*	23- 9
*	23-12
*	23-28
*	29- 3
*	30- 8
*	30-16
*	30-19
WIRE, earth lead	30-19

—MEMO—

A series of horizontal dotted lines for writing, spanning the width of the page.