



YAMAHA MBK

TZR50 '03

X-POWER '03

5WX-AE1

SERVICE MANUAL

**TZR50'03 / X-POWER'03
SERVICE MANUAL**
© 2003 by Yamaha Motor España, S.A.
1st Edition, December 2003
All rights reserved
Any reproduction or non-authorized use of this
material
is expressly prohibited without the consent of
Yamaha Motor España, S.A.

WARNING

This manual has been issued by Yamaha Motor España, S.A., mainly for its use by Yamaha /MBK dealers and their qualified mechanics. It is not possible to include the full training of a mechanic in a manual, for which reason we take it for granted that the persons who use this manual to carry out maintenance and repair work on Yamaha /MBK motorcycles basically understand mechanical concepts and procedures inherent to motorcycle repair technology. Without such knowledge, any attempts to repair or service this model may make it inappropriate for use and/or dangerous.

Yamaha Motor España, S.A. makes a constant effort to improve all the models that it manufactures. Any significant modifications and changes which are brought into the specifications or procedures will be made known to all Authorised Yamaha/MBK dealers and will appear, where applicable, in future editions of this manual.

**TECHNICAL PUBLICATIONS
AFTER-SALES SERVICE
YAMAHA MOTOR ESPAÑA, S.A**

HOW TO USE THIS MANUAL

INFORMATION OF PARTICULAR IMPORTANCE

This material is distinguished by the following annotations:



A danger symbol means: DANGER! TAKE CARE! YOUR SAFETY IS AT RISK!

WARNING

Failure to comply with a WARNING *may lead to serious injuries or death for the rider, a bystander or the person inspecting or repairing the motorcycle.*

CAUTION

CAUTION indicates the special precautions which have to be taken to prevent damage to the motorcycle.

NOTE:

A NOTE provides key information for making procedures easier or clearer.

MANUAL FORMAT

















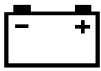



All the procedures included in this manual are arranged in sequential format, divided into stages. The information presented has been grouped together in order to give the mechanic a reference that is easy to read and convenient to handle, containing exhaustive explanations of all the operations for dismantling, repair, assembly and inspection.

In this reviewed format, the condition of each faulty component is followed by an arrow, which will in turn be followed by the operation required; for example:

- Bearing
- Pitting / Deterioration → Replace

EXPLODED VIEWS

Each chapter includes exploded views, before each dismantling section, to facilitate identification of the right procedures for dismantling and assembly.

① GEN INFO 	② SPEC 	
③ INSP/ADJ 	④ ENG 	
⑤ CARB 	⑥ CHAS 	
⑦ ELEC 	⑧ TRBL ?	
⑨ 	⑩ 	
⑪ 	⑫ 	
⑬ 	⑭ 	
⑮ 		
⑯ 	⑰ 	⑱ 
⑲ 	⑳ 	㉑ 
㉒ 	㉓ NEW	

SYMBOLS ILLUSTRATED

(See the illustration)

Symbols ① to ⑧ are designed as thumb tabs, in order to show the number of the chapter and index

- ① General information
- ② Specifications
- ③ Regular inspection and adjustments
- ④ General engine servicing
- ⑤ Carburation
- ⑥ Chassis
- ⑦ Electrical system
- ⑧ Troubleshooting - location and repair of faults









Symbols ⑨ to ⑮ are used to identify the specifications appearing in the text

- ⑨ Filling liquid
- ⑩ Lubricant
- ⑪ Special tool
- ⑫ Tightening
- ⑬ Limit of wear or clearance
- ⑭ Engine speed
- ⑮ Ω, V, A

Symbols ⑯ to ㉓ of the detailed diagrams indicate the grade of lubricant and the location of the lubrication point.

- ⑯ Apply engine oil
- ⑰ Apply gearbox oil
- ⑱ Apply molybdenum bisulphide oil
- ⑲ Apply grease for wheel bearings
- ㉑ Apply lightweight lithium soap-based grease
- ㉒ Apply molybdenum bisulphide grease
- ㉓ Apply locking agent (LOCTITE®)
- ㉔ Use a new one

INDEX

GENERAL INFORMATION	
	GEN/ INFO 1
SPECIFICATIONS	
	SPEC 2
REGULAR INSPECTIONS AND ADJUSTMENTS	
	INSP ADJ 3
DISMANTLING THE ENGINE	
	ENG 4
COOLING SYSTEM	
	COOL 5
CARBURATION	
	CARB 6
CHASSIS	
	CHAS 7
ELECTRICAL SYSTEM	
	ELEC 8

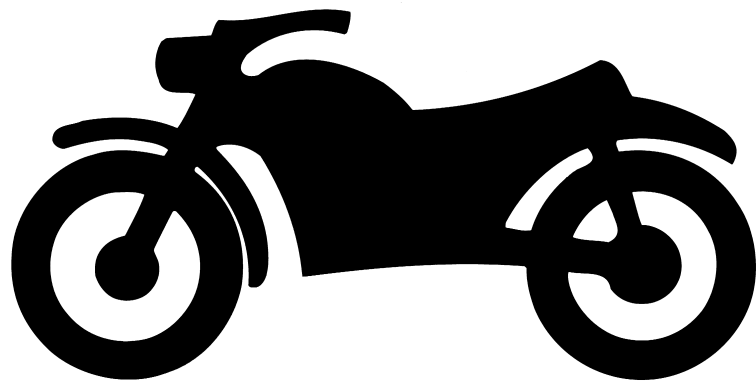

**GEN/
INFO**

1

CHAPTER 1

GENERAL INFORMATION

IDENTIFICATION OF THE MOTORCYCLE	1-1
FRAME SERIAL NUMBER	1-1
ENGINE SERIAL NUMBER.....	1-1
 IMPORTANT INFORMATION	 1-2
PREPARATION FOR REMOVAL AND DISMANTLING	1-2
SPARES	1-3
GASKETS, OIL SEALS AND O RINGS.....	1-3
WASHERS, LOCKING PLATES AND SPLIT PINS	1-3
BEARINGS AND OIL SEALS	1-3
CIRCLIPS	1-4
 SPECIAL TOOLS	 1-4
FOR TUNING	1-4
FOR ENGINE SERVICE	1-4
FOR CHASSIS SERVICE	1-7
FOR ELECTRICAL COMPONENTS	1-8

IDENTIFICATION OF THE MOTORCYCLE

GEN/
INFO

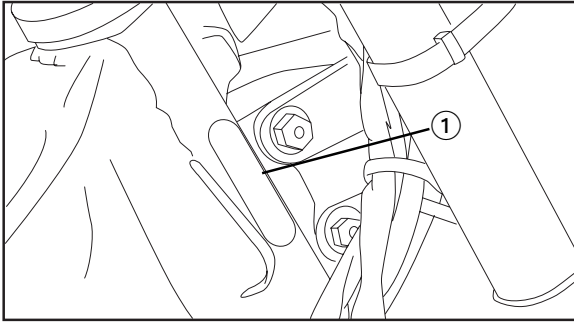

GENERAL INFORMATION IDENTIFICATION OF THE MOTORCYCLE

FRAME SERIAL NUMBER

The chassis serial number ① is printed on the right-hand side of the steering head.

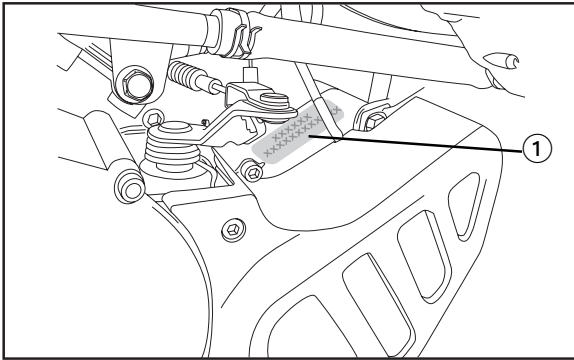

ENGINE SERIAL NUMBER

The engine serial number ① is printed on the left-hand side of the engine.

NOTE:

The first three figures of these numbers are for identifying the model: the others are the machine manufacturing number.

NOTE:

Design and characteristics subject to modification at no prior notice.

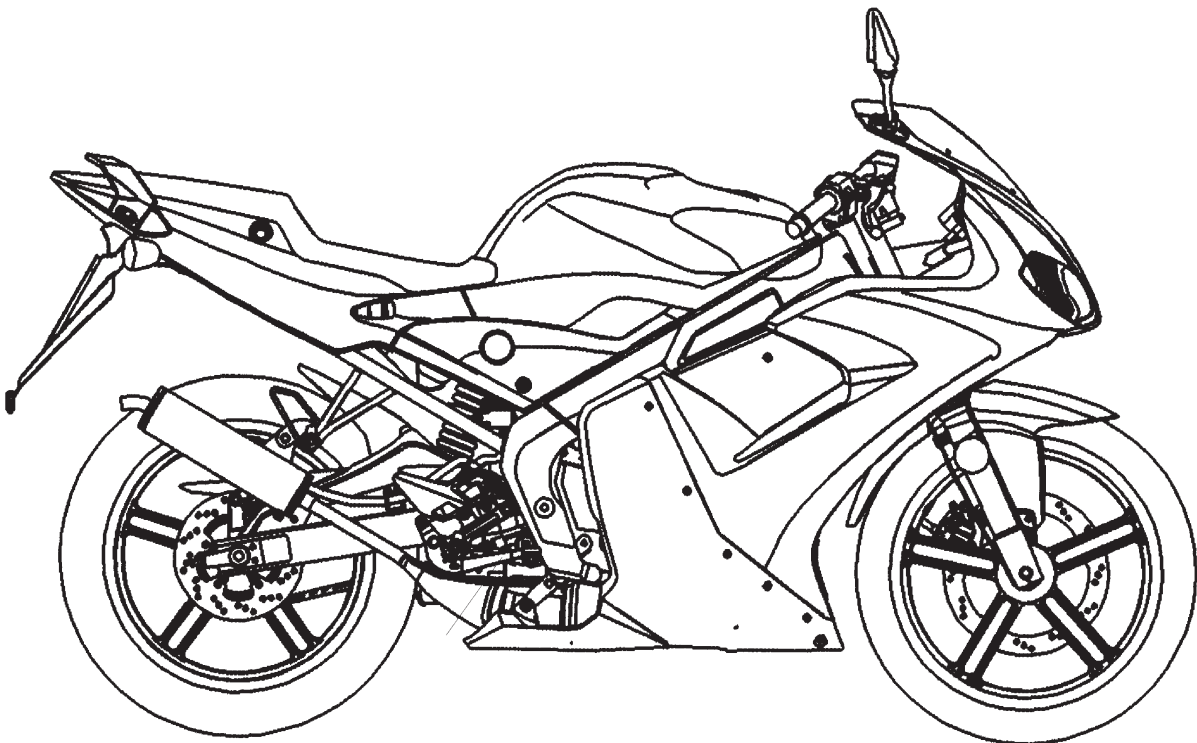

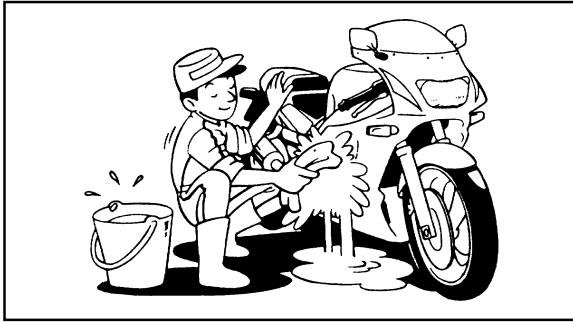

**IMPORTANT INFORMATION
PREPARATION FOR REMOVAL
AND DISMANTLING**

1. Before starting removal and dismantling, remove any dirt, mud, dust and foreign bodies.

2. Use appropriate tools and cleaning equipment
See "SPECIAL TOOLS"

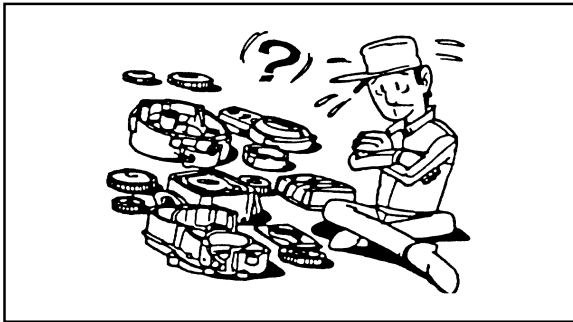

3. When dismantling the motorcycle, keep any matching parts together. This refers to gears, cylinders and pistons and other items which work together and undergo the same normal wear. Matching parts must be assembled or replaced together.

4. As you dismantle the motorcycle, clean all the parts and place them in trays, in the same order in which these are dismantled. This will cut down the time required for assembly and will make it easier to install them all together.

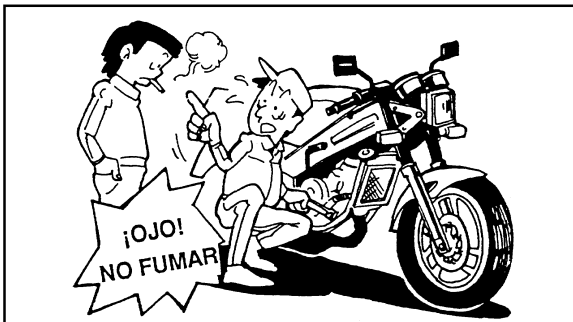

5. Keep any fire well away. **CAREFUL ! NO SMOKING !**

SPARES

1. Use only original Yamaha/MBK spares for all changes. Use the oils and /or greases recommended by Yamaha/MBK for assembly and adjustments. Other makes may have the same function and appearance but nevertheless be of lower quality.

GASKETS, OIL SEALS AND O RINGS

1. When an engine is dismantled, all the gaskets, oil seals and O rings must be replaced. All the surfaces of all the gaskets and the lips of oil seals and O rings must also be cleaned.
2. When assembling, properly lubricate all bearings and matching parts. Apply grease to the lips of oil seals.

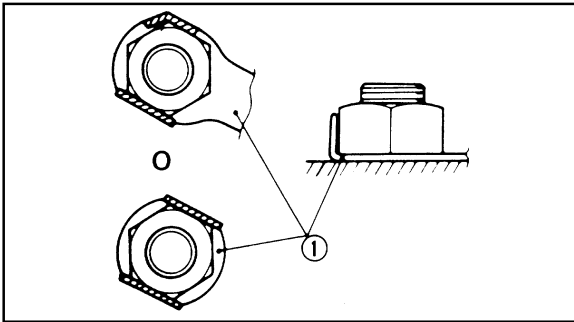

WASHERS AND LOCKING TABS AND SPLIT PINS

1. All washers/locking tabs (1) and split pins have to be replaced and when locking tabs are removed and replaced they must be folded over the sides of the bolts or nuts, after these have been properly tightened.

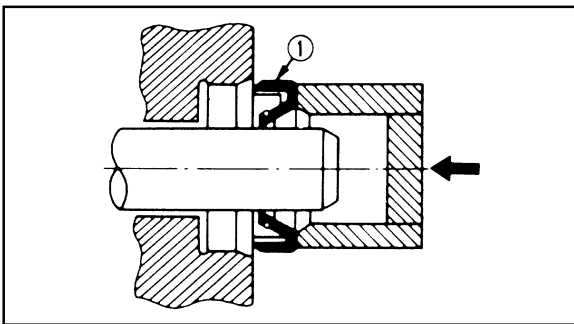

BEARINGS AND OIL SEALS

1. Install the bearings and oil seals with the makes or manufacturer numbers facing outwards. (This means that the printed letters should be visible). When installing oil seals, apply a thin layer of light lithium grease to the lips. Put plenty of oil on bearings when installing these.

① Oil seal

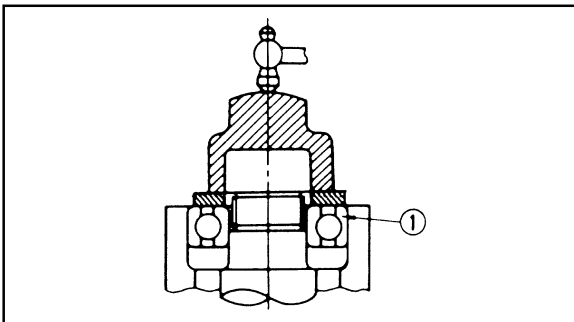

CAUTION

Do not use compressed air to dry bearings. This method damages the surface of these items.

① Bearing

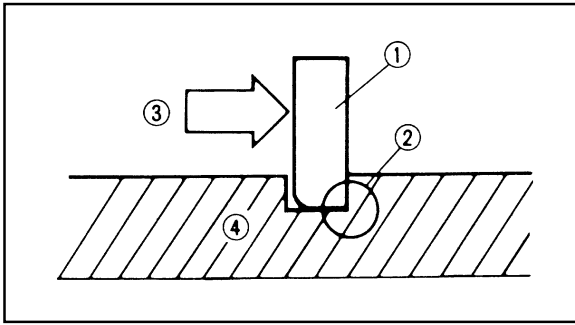

CIRCLIPS

1. All circlips must be carefully inspected before installing these again.
Always change the ones on the piston rods when these are worn. Change any circlip that has become deformed. When installing a circlip ① make sure that the sharp edge ② is facing opposite the direction of the thrust ③ that this receives. See the section drawing.

④ Axis

SPECIAL TOOLS

For full and accurate tuning and installing the appropriate special tools must be used. This will prevent any damage that could arise from using inappropriate tools or improvised techniques.

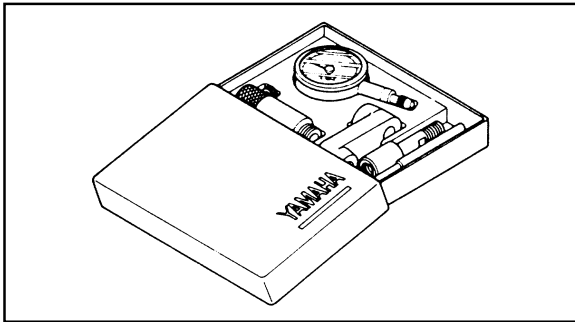

FOR TUNING

1. Comparator set
Ref. 90890-01252

This tool is used for installing the comparator and tune the motor.

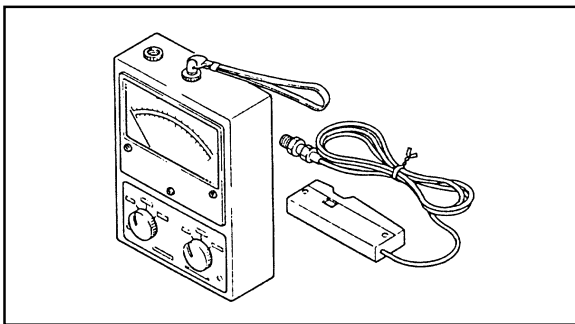

2. Digital tachometer for the engine
Ref. 90890-03113

This tool is required for determining the engine speed in rpm.

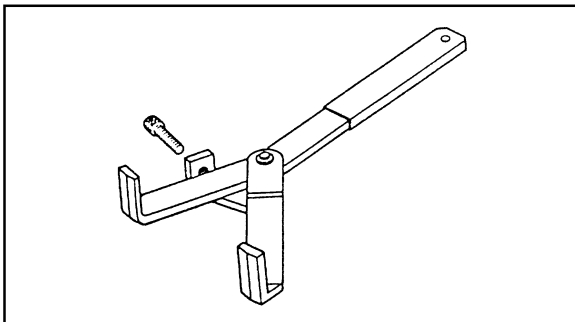

FOR ENGINE SERVICE

1. Universal clutch holder
Ref. 90890-04086

This tool is used for immobilising the clutch when this is loosened or when the boss locking nut is tightened.

SPECIAL TOOLS

GEN/
INFO

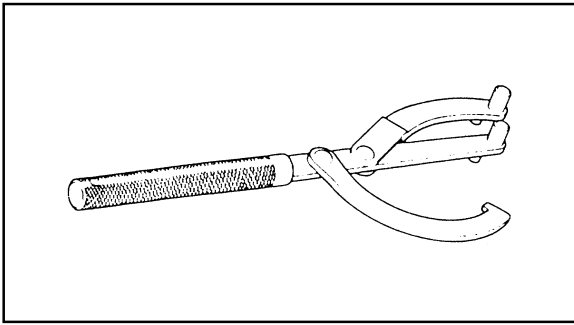

2. Flywheel (rotor) holding tool
Ref. 90890-01235

This tool is used when the securing screw for the magnetic flywheel magneto has to be tightened or loosened.

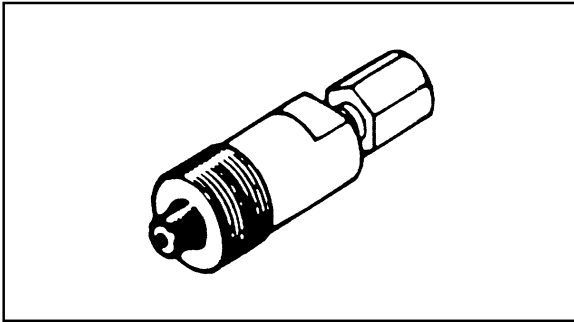

3. Magnetic flywheel extractor
Ref. 90890-11031

This tool is used for dismantling the magnetic flywheel.

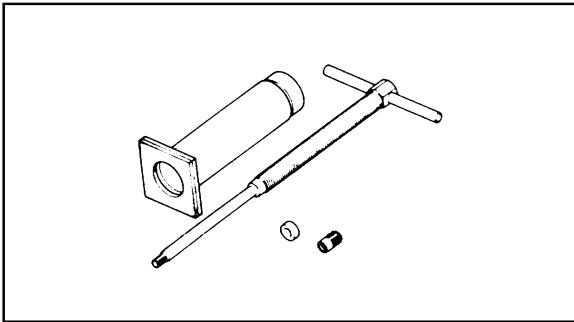

4. Pin extractor
Ref. 90890-01304

This tool is used for removing the piston pin.

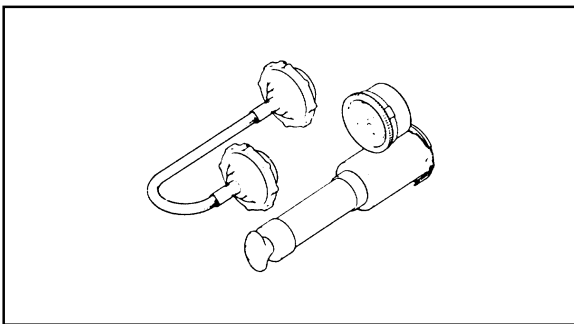

5. Cooling system checker
Ref. 90890-01325

This tool is required for checking the cooling system.

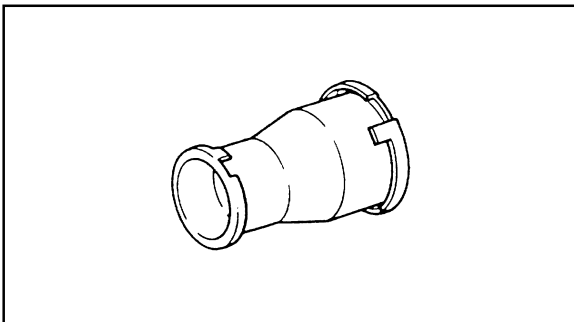

6. Adapter
Ref. 90890-01352

This system is used for checking the cooling system.

SPECIAL TOOLS

GEN/
INFO

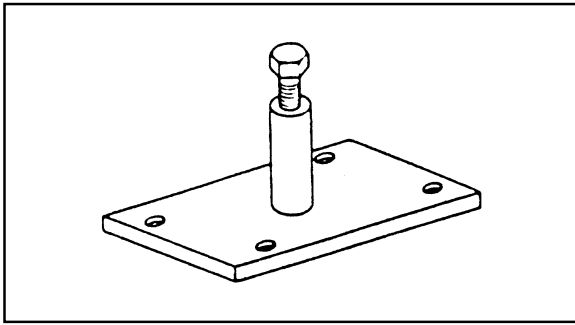

7. Crankcase remover tool
Ref. 90890-11030

This tool is used for dismantling the crankshaft or removing the crankcase.

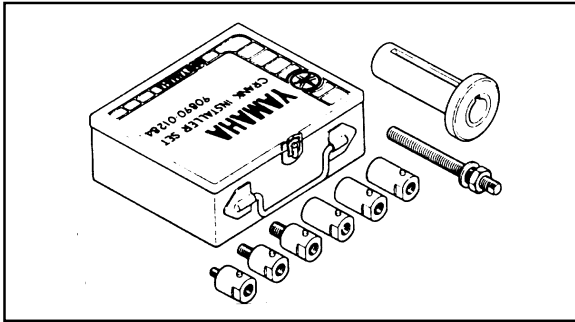

8. Tools for installing the crankshaft.
Ref. 90890-01284

These tools are used for installing the crankshaft.

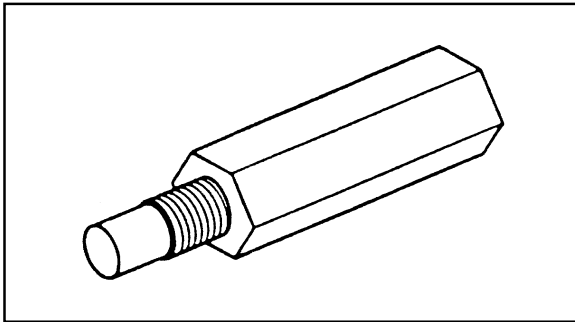

9. Crankcase installer
(Magnetic flywheel side)
Ref. 90890-11032

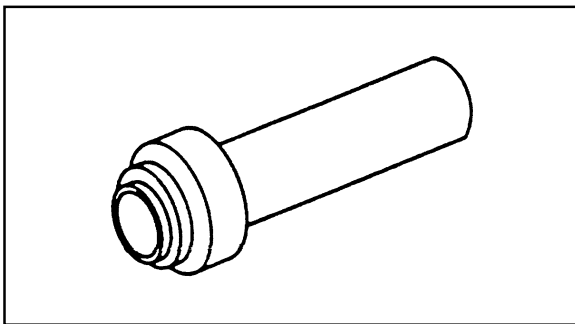

10. Seal installer
(Selector axle)
Ref. 90890-11033

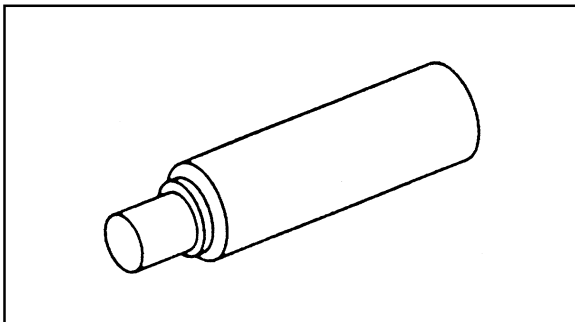

11. Seal installer
(Water pump)
Ref. 90890-11034

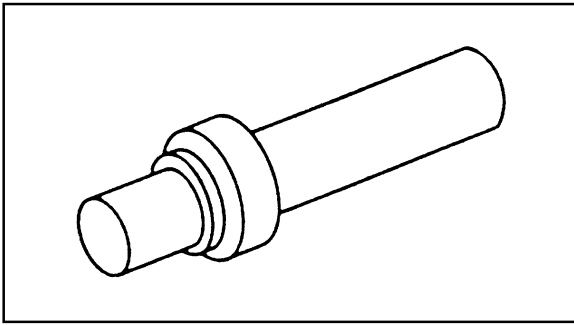

12. Seal installer
(Clutch lever)
Ref. 90890-11035

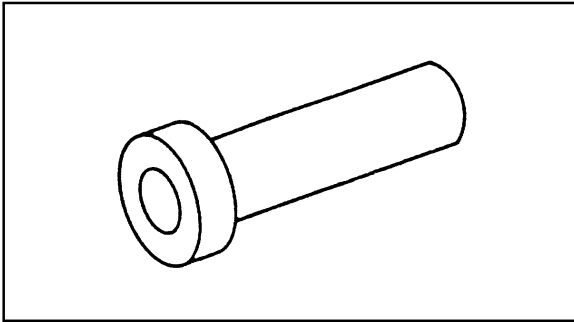

13. Seal installer
(Clutch side of crankshaft)
Ref. 90890-11036)

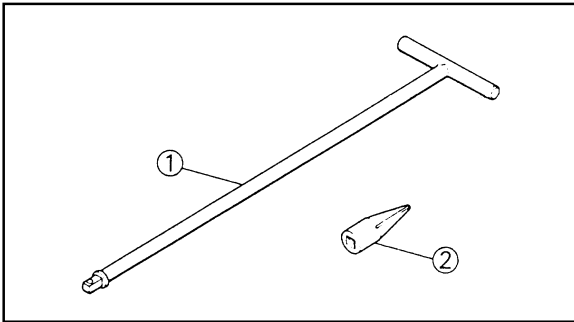

FOR CHASSIS SERVICE

1. "T" tool _____ ①
Ref. 90890-01326 _____
Front fork cylinder holder _____ ②
Ref. 90890-01294

This tool is used to loosen and tighten the fixing bolts for the cylinders of the front fork.

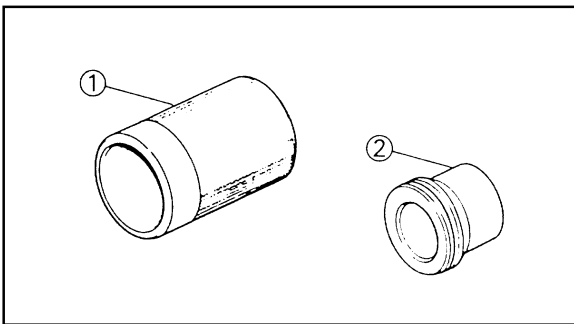

2. Front fork seal fitter (weight) _____ ①
Ref. 90890-01367 _____
Adapter _____ ②
Ref. 90890-01400

These tools are used for installing the seals on the front fork.

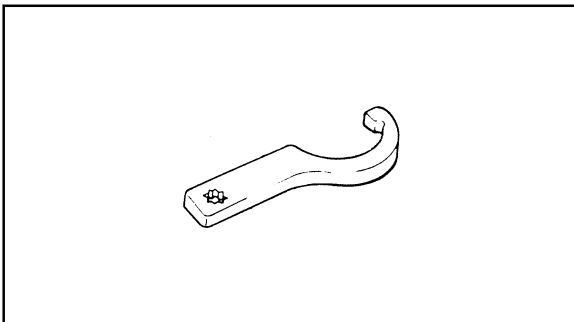

3. Wrench for circular nuts
Ref. 90890-01403

This tool is used for loosening and tightening the circular steering nut.

SPECIAL TOOLS

GEN/
INFO

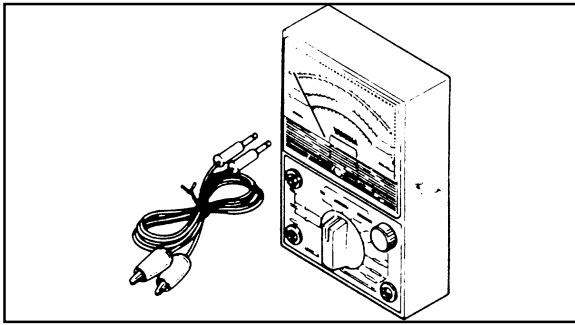

FOR ELECTRICAL COMPONENTS

1. Pocket tester
Ref. 90890-03112

This tester is an invaluable help for checking the electrical system.

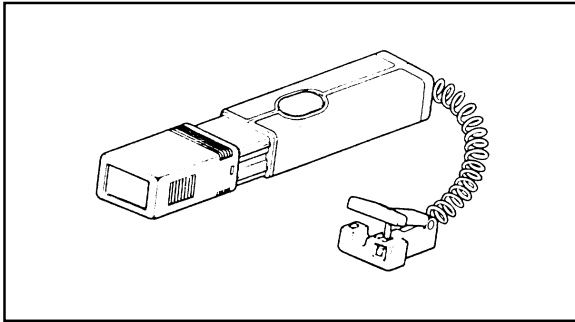

2. Stroboscopic lamp
Ref. 90891-03141

This tool is required for checking the ignition advance.

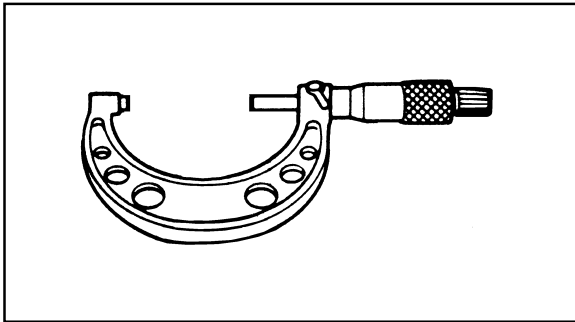

OTHER TOOLS

1. Micrometer
Ref. 90896 - 03008

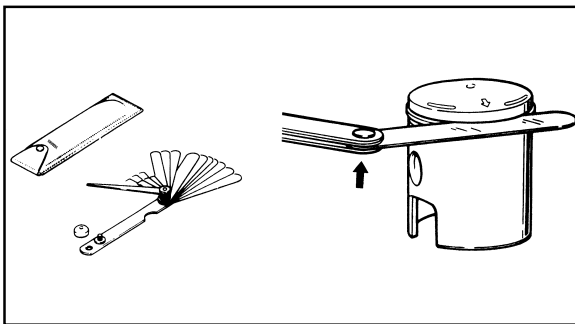

2. Feeler gauge
Ref. 90890-03079

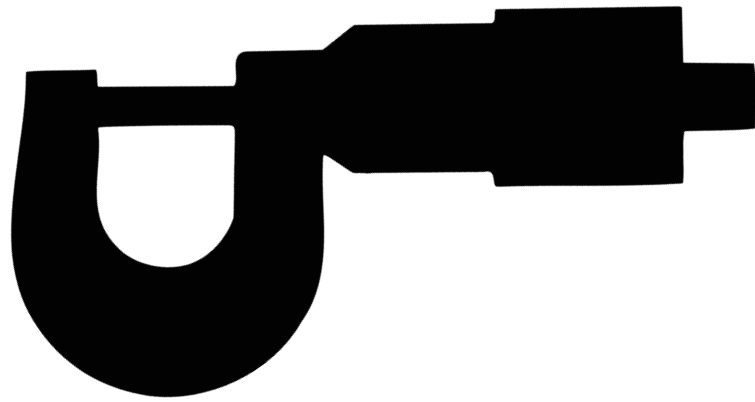

SPEC

2

CHAPTER 2
GENERAL SPECIFICATIONS

SPECIFICATIONS2-1

GENERAL SPECIFICATIONS2-1

MAINTENANCE SPECIFICATIONS2-4

 ENGINE2-4

 CHASSIS2-7

 TIGHTENING TORQUES2-9

 ELECTRICAL SYSTEM2-11

**GENERAL SPECIFICATIONS OF TIGHTENING TORQUES/
DEFINITION OF THE UNITS**2-13

LUBRICATION POINTS AND TYPE OF LUBRICANT2-14

 ENGINE2-14

 CHASSIS2-15

CABLE ROUTING2-16



SPECIFICATIONS
GENERAL SPECIFICATIONS

Model	TZR50 / X-POWER
Model code number	5WX
Frame serial number Yamaha MBK	UTLRA031000000001 UTLRA032000000001
Dimensions: Total length Total width Total height Height of the seat Distance between axles Minimum ground clearance	2007 mm 675 mm 1065 mm 815 mm 1330 mm 144 mm
Basic weight: With oil and full fuel tank	124.2 kg.
Minimum turning radius	2900 mm
Engine: Type of engine Admission system Cylinder arrangement Cylinder capacity Bore x stroke Compression ratio Starting system Lubrication system	2 stroke, petrol, liquid cooled Reed valve Single cylinder, slanting forwards 49.7 cm ³ 40.3 x 39 mm 6.85:1 Electric Independent lubrication
Motor oil Type Capacity	Yamaha 2 stroke oil or oil for air-cooled 2 stroke engines 1.35 L
Transmission oil: Type Capacity: Regular oil change Total amount	Engine oil SAE 10W30 SE type 0.75 L 0.82 L
Capacity of coolant: Including all routes	0.7 L
Air filter: Type	Damp element

GENERAL SPECIFICATIONS

SPEC



Model	TZR50 / X-POWER	
Fuel: Type Capacity of the fuel tank: Full Reserve	Unleaded gasoline 13.8 L 2.2 L	
Carburettor : Type / Number Manufacturer	PHBN 16 NS/1 DELLORTO	
Spark plug Type / Number Manufacturer Spark plug gap	BR9ES/1 piece N.G.K. 0.6 ~ 0.7 mm	
Clutch: Type	Wet, multi disc	
Transmission: Type Primary reduction system Primary reduction ratio Secondary reduction system Secondary reduction ratio Action Gear reduction ratio: 1st 2nd 3rd 4th 5th 6th	6 gears constant mesh Helical gear 71/20 (3,550) Drive chain 47/12 (3.916) Left foot 36/12 (3,000) 33/16 (2,062) 29/19 (1,526) 27/22 (1,227) 25/24 (1,041) 24/25 (0,960)	
Chassis: Frame type Caster angle Trail	Double cradle (Deltabox) 25° 92 mm	
Tyres: Type: Dimensions: Front Rear	Tubeless 100/80-17 52H 130/70-17 62H	
Maximum load*	183 kg.	
Cold tyre pressure: Up to 90 kg. (198 pounds) load* From 90 kg. (198 pounds) up to max. load	FRONT	REAR
	1.8 kg/cm ²	2.0 kg/cm ²
	1.9 kg/cm ²	2.3 kg/cm ²

GENERAL SPECIFICATIONS

SPEC



Model	TZR50 / X-POWER
Brakes: Type of front brake Front brake action Type of rear brake Rear brake action	Single disc Right hand Single disc Right foot
Suspension: Front suspension type Rear suspension type	Telescopic fork Swinging arm (Monocross suspension)
Damping: Front shock absorber Rear shock absorber	Spiral spring / oil shock absorber Spiral spring and gas/oil damping
Wheel travel: Front wheel Rear wheel	130 mm 102 mm
Electrical system Ignition system Charging system	C.D.I. AC Magneto
Battery: Type Capacity	YT4L-BS 12V, 3A
Headlights: Type	Dual filament bulb
Bulb voltage, wattage x quantity Headlight Tail and brake light Indicators Instrument panel light Neutral indicator light "NEUTRAL" "OIL" indicator "TURN" indicator Coolant temperature indicator	25/25W x 2 5/21Wx 1 10Wx 4 1.2W x 2 LED x 1 LED x 1 LED x 1 LED x 1
General voltage:	12V

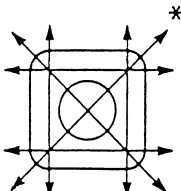
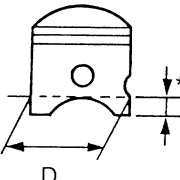
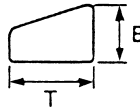
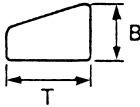

**MAINTENANCE SPECIFICATIONS
ENGINE**

Model	TZR50 / X-POWER
Cylinder head: Max. waparge 	0.03 mm * Lines indicate straightedge measurement.
Cylinder: Bore size Taper limit Out of round limit	40,293 ~40,312 mm <Limit> <40.4mm> 0.05 mm 0.01 mm
Piston: Piston size "D" Measurement point "*" 	40.237 ~ 40.257 mm 12 mm
Piston to cylinder clearance 1st oversize 2nd oversize	0.049 ~0.062 mm <Limit> <0.1 mm> 40.60 mm 40.80 mm
Rings: Top ring  Second ring  End gap (installed) Top ring 2nd ring Side clearance Upper ring 2nd ring	Chrome plated type B = 1.2 mm T = 1.6 mm Chromed type B = 1.2 mm T = 1.6 mm 0.15 ~ 0.30 mm 0.15 ~ 0.30 mm 0.03 ~ 0.06 mm 0.03 ~ 0.06 mm

MAINTENANCE SPECIFICATIONS

SPEC



Model	TZR50 / X-POWER
<p>Crankshaft:</p> <p style="padding-left: 20px;">Crank width "A"</p> <p style="padding-left: 20px;">Runout limit "B"</p> <p style="padding-left: 20px;">Small end free play "D"</p> <p style="padding-left: 20px;">Big end side clearance "C"</p> <div style="text-align: center; margin-top: 20px;"> </div>	<p>41.90 ~ 42.0 mm</p> <p>0.03 mm</p> <p>0.20 ~ 0.61 mm</p> <p>0.015 ~ 0.026 mm</p>
<p>Clutch:</p> <p style="padding-left: 20px;">Friction plate:</p> <p style="padding-left: 40px;">Thickness</p> <p style="padding-left: 40px;">Number</p> <p style="padding-left: 40px;">Wear limit</p> <p style="padding-left: 20px;">Clutch plate:</p> <p style="padding-left: 40px;">Thickness</p> <p style="padding-left: 40px;">Number</p> <p style="padding-left: 40px;">Wear limit</p> <p style="padding-left: 20px;">Clutch spring:</p> <p style="padding-left: 40px;">Free length</p> <p style="padding-left: 40px;">Number</p> <p style="padding-left: 20px;">Clutch release method:</p> <p style="padding-left: 40px;">Pushrod bending limit</p>	<p>2.9 ~ 3.1 mm</p> <p>4 pieces</p> <p>2.7 mm</p> <p>1.05 ~ 1.35 mm</p> <p>3 pieces</p> <p>0.05 mm</p> <p>30.0 mm</p> <p>4 pieces</p> <p>Internal pusher, cam pusher</p> <p>0.15 mm</p>
<p>Transmission:</p> <p style="padding-left: 20px;">Eccentricity limit of the primary shaft</p> <p style="padding-left: 20px;">Eccentricity limit of the secondary shaft</p>	<p>0.08 mm</p> <p>0,08 mm</p>
<p>Selector:</p> <p style="padding-left: 20px;">Type</p>	<p>Drum</p>
<p>Air filter:</p> <p style="padding-left: 20px;">Oil type</p>	<p>Oil for foam filter or SAE 10W30SE</p>

MAINTENANCE SPECIFICATIONS

SPEC



Model	TZR50 / X-POWER
Carburettor: Identification mark Main jet Air screw turns Fuel level Float height Idling speed Idling jet Starter jet Air jet Needle jet Jet needle Section Bypass 1 Valve seat size	PHBN12HS/Dellorto (M.J.) # 88 2-1/8 5 mm (F.H.) 14.3 ± 0.5 mm 1850 ± 150 rpm # 32 # 45 100 A13 210FQ 4 0.80 150
Reed valve: Valve thickness Valve stopper height Valve bending limit	0.3 mm 6.28 mm 0.1 ~ 0.7 mm
Lubrication system: Autolube pump: Piston diameter Minimum flow at 3000 rpm Maximum flow at 3000 rpm Pulley adjusting wark	2.5 mm 6 cc/h 28 cc/h By keeping the throttle twist grip closed
Cooling system: Radiator core width Radiator core height Radiator core thickness Radiator cap opening pressure Reservoir tank capacity Water pump type	160.0 mm 160.0 mm 32.0 mm 0.9 kg/cm ² 0.71 L Single-suction centrifugal pump



CHASSIS

Model	TZR50 / X-POWER
Steering system: Steering type Size of the balls (number): Upper Lower	Ball bearings 1/4 inch (19 units) 1/4 inch (19 units)
Front suspension: Front fork travel Fork free leng 515.1 mm <Limit> Spring rate (K1) (K2) Spiring stroke (K1) (K2) Optional spring Oil capacity Oil level Oil type	130.0 mm <508 mm> 0.4 kg/mm 0.55 kg/mm 0.0 ~ 70 mm 70 ~ 130 mm No 254 cm ³ 150 mm From the top edge of the lower tube, fully compressed, without spring. Fork oil 10W or equivalent
Rear suspension: Rear shock absorber assembly travel Spring free lenght <Limit> Installed lenght Spring rate (K1) Spring stroke (K1) Optional spring	102 mm 147 mm <132> mm 134 mm 14 kg/mm 28 mm No
Swingarm: Limit of free play (end of the swingarm)	1.0 mm Move the swingarm from side to side
Front wheel: Type Wheel size Wheel material Runout limit Vertical Lateral	Cast MT2.75 x 17 Aluminium 2.0 mm 2.0 mm

MAINTENANCE SPECIFICATIONS

SPEC



Model	TZR50 / X-POWER
Rear wheel: Type Wheel size Wheel material Runout limit Vertical Lateral	Cast MT3.50 x 17 Aluminium 1.0 mm 1.0 mm
Drive chain: Type / Manufacturer Number of links Chain slack	415H90R/Regina 133 20 ~ 25mm
Front disc brake: Type Thickness Brake pad thickness <Wear limit> Master cylinder inside diameter Caliper cylinder inside diameter Recomended fluid	Single disc 280.0 x 4,0 mm 4.3 mm <0.5mm> 12.0 mm 25.0 mm DOT 4
Rear disc brake: Type Thickness Brake pads thickness <Wear limit> Master cylinder inside diameter Caliper cylinder inside diameter Recomended fluid	Single disc 220.0 x 4,0 mm 4 mm <0.5 mm> 12.0 mm 30.0 mm DOT 4
Front lever brake/Rear brake pedal: Free play front lever brake Brake pedal free play	2 ~ 5 mm At the end of the brake handle 45 mm Under the top side of the footrest
Clutch lever and throttle twist grip: Clutch lever free play Throttle cable free play	2 ~ 3 mm 2 ~ 5 mm



TIGHTENING TORQUES

Items to tighten	Number	Thread pitch	Tightening torque		Observations
			Nm	m•kg	
Spark plug	1	M14 x 1.25	23	2.3	
Cylinder head Nuts	4	M7 x 1.0	17	1.7	
Cylinder Bolts	4	M8 x 1.25	18	1.8	
Coolant draining plug	1	M6 x 1.0	5	0.5	
Water pump cover Screw	3	M6 x 1.0	5	0.5	
Thermostat bolt	2	M4 x 0.7	2	0.2	
Water pump Bolt	2	M5 x 0.8	7	0.7	
Carburetor joint Screw	4	M6 x 1.0	10	1.0	
Crankcase (left right) Screw	13	M6 x 1.0	10	1.0	
Bolt	4	M7 x 1.0	12	1.2	
Crankcase cover 1 Bolt	5	M5 x 0.8	5	0.5	
Crankcase cover 2 Bolt	4	M6 x 1.0	10	1.0	
Crankcase cover 3 Crankcase cover 1	2	M5 x 98	4.5	0.45	
Oil drain plug	1	M8 x 1.25	17	1.7	
Intermediate shaft Nut	1	M12 x 1.0	60	6.0	
Clutch Nut	1	M12 x 1.25	75	7.5	
Screw	4	M5 x 0.8	4	0.4	
Push rod nut	1	M14 x 1.25	27	2.7	
Shift pedal Screw	1	M8 x 1.25	30	3.0	
Starter motor Screw	2	M6 x 1.0	10	1.0	
Flywheel	1	M10 x 1.25	52	5.2	



TIGHTENING TORQUES

Items to tighten	Number	Thread pitch	Tightening torque		Observations
			Nm	m•kg	
Upper bracket and forks Allen screw	2	M8 x 1.25	22	2.2	
Upper bracket and shaft	1	M14 x 1.25	56	5.6	
Steering shaft and nut	1	M25 x 1.0	6	0.6	Initial 37 Nm Loosen and tighten
Handlebar to forks	2	M8 x 1.25	22	2.2	
Handlebar to upper bracket	2	M6 x 1.0	10	1.0	
Handlebar to brake pump	2	M6 x 1.0	10	1.0	
Front fairing bracket	2	M8 x 1.25	23	2.3	
Engine to frame holder	2	M8 x 1.25	25	2.5	
Engine to front holder	2	M8 x 1.25	25	2.5	Lower
Engine to rear holder frame	1	M8 x 1.25	25	2.5	Upper
Engine to rear frame holder	1	M8 x 1.25	25	2.5	Lower
Swing arm to frame	1	M8 x 1.25	60	6.0	
Shock absorber to swingarm	1	M8 x 1.25	60	6.0	
Shock absorber to frame	1	M8 x 1.25	40	4.0	
Fuel tank cap to fuel tank	1	M6 x 1.0	6.5	0.65	
Front wheel axle to fork	1	M12 x 1.25	65	6.5	
Rear wheel axle and nut	1	M14 x 1.25	90	9.0	
Disc brake to wheel	5	M6 x 1.0	12	1.2	
Brake caliper to bracket	2	M8 x 1.25	35	3.5	
Rear sprocket to wheel	4	M8 x 1.25	48	4.8	
Brake line	1	M10 x 1.25	63	6.3	
Front caliper bleed screw	1	M10 x 1.0	14	1.4	
Rear caliper bleed screw	1	M10 x 1.0	14	1.4	
Fork tightening screw	1	M8 x 1.25	24	2.4	
Rear brake pump and support	2	M10 x 1.25	24	2.4	
Axle to support 3	1	M10 x 1.25	36	3.6	
2/3 support to frame	2	M8 x 1.25	30	3.0	



ELECTRICAL SYSTEM

Model	TZR50 / X-POWER																						
Voltage:	12 V																						
<p>Ignition system</p> <div style="text-align: center;"> <table border="1"> <caption>Ignition Advance Data</caption> <thead> <tr> <th>Rotar shaft (RPM)</th> <th>Advance (Rotar shaft degree)</th> </tr> </thead> <tbody> <tr><td>500</td><td>24</td></tr> <tr><td>2000</td><td>24</td></tr> <tr><td>4000</td><td>24</td></tr> <tr><td>6000</td><td>22</td></tr> <tr><td>8000</td><td>20</td></tr> <tr><td>10000</td><td>18</td></tr> <tr><td>12000</td><td>16</td></tr> </tbody> </table> </div> <p>Ignition data:</p> <table border="0"> <tr> <td>Type of advance arrangement:</td> <td>Electronic</td> </tr> <tr> <td>Ignition:</td> <td>14°/2000 r/min</td> </tr> <tr> <td>Advance:</td> <td>24°/2000 r/min</td> </tr> </table>		Rotar shaft (RPM)	Advance (Rotar shaft degree)	500	24	2000	24	4000	24	6000	22	8000	20	10000	18	12000	16	Type of advance arrangement:	Electronic	Ignition:	14°/2000 r/min	Advance:	24°/2000 r/min
Rotar shaft (RPM)	Advance (Rotar shaft degree)																						
500	24																						
2000	24																						
4000	24																						
6000	22																						
8000	20																						
10000	18																						
12000	16																						
Type of advance arrangement:	Electronic																						
Ignition:	14°/2000 r/min																						
Advance:	24°/2000 r/min																						
<p>CDI:</p> <table border="0"> <tr> <td>Magneto model / manufacturer</td> <td>MORIC 5WX</td> </tr> <tr> <td>Pickup resistance (color)</td> <td>350 ± 20% Ω(WR-WL)</td> </tr> <tr> <td>Charge coil resistance (color)</td> <td>0.36 ± 20% Ω(W)</td> </tr> <tr> <td>Lighting coil resistance (color)</td> <td>0.28 ± 20% Ω(YR)</td> </tr> </table>	Magneto model / manufacturer	MORIC 5WX	Pickup resistance (color)	350 ± 20% Ω(WR-WL)	Charge coil resistance (color)	0.36 ± 20% Ω(W)	Lighting coil resistance (color)	0.28 ± 20% Ω(YR)															
Magneto model / manufacturer	MORIC 5WX																						
Pickup resistance (color)	350 ± 20% Ω(WR-WL)																						
Charge coil resistance (color)	0.36 ± 20% Ω(W)																						
Lighting coil resistance (color)	0.28 ± 20% Ω(YR)																						
<p>Ignition coil:</p> <table border="0"> <tr> <td>Model / Manufacturer</td> <td>MORIC 5WX</td> </tr> <tr> <td>Secondary coil resistance</td> <td>7.9 KΩ</td> </tr> </table>	Model / Manufacturer	MORIC 5WX	Secondary coil resistance	7.9 KΩ																			
Model / Manufacturer	MORIC 5WX																						
Secondary coil resistance	7.9 KΩ																						
<p>Spark plug pipe:</p> <table border="0"> <tr> <td>Type</td> <td>Resin</td> </tr> <tr> <td>Resistance</td> <td>5 K W at 20 °C</td> </tr> </table>	Type	Resin	Resistance	5 K W at 20 °C																			
Type	Resin																						
Resistance	5 K W at 20 °C																						

MAINTENANCE SPECIFICATIONS

SPEC



Model	TZR50 / X-POWER
Charge system:	Flywheel magneto
Voltage regulator: Model / manufacturer	SH 671 - 12/SHIN DEN GEN
Battery: Type	MF (no maintenance)
Horn: Type Amount Model/Manufacturer Maximum amperage	Plain type 1 GH/12/NIKKO 1.5A
Flasher relay: Model / Manufacturer Self-cancelling device Flashing frequency Power in watts	0.1 - 2336/GUILERA No 60 ~ 120 cycles per minute 10W + 16W + 1.2 W
Oil level switch: Model / Manufacturer	21.57.057.A/PAIOLI
Temperature sensor: Model / Manufacturer	5017520 / Anglí
Starter relay: Model / Manufacturer	12V - 50A / Guilera
Circuit breaker: Type	Fuse
Circuit (fuse) MAIN	10 A
Electrical start system: Type	Constant mesh
Starter motor: Manufacturer Power output	MISTUBA 0.13 KW

GENERAL CHARACTERISTICS OF TIGHTENING TORQUES

This table specifies the tightening torques for ordinary fixings with standard ISO pitch threads. The characteristics of the tightening torques of special components or assemblies are stated in the relevant sections of this manual. To avoid any deformation, tighten the assemblies with several fixing points in a cross pattern and in gradual stages, until the final tightening torque is reached. Unless specified otherwise, the characteristics of the tightening torque refer to clean dry threads. The components must be at ambient temperature.

A (nut)	B (bolt)	General characteristics of the tightening torques		
		Nm	m • kg	lb•foot
10 mm	6 mm	6	0.6	4.3
12 mm	8 mm	15	1.5	11
14 mm	10 mm	30	3.0	22
17 mm	12 mm	55	5.5	40
19 mm	14 mm	85	8.5	61
22 mm	16 mm	130	13.0	94

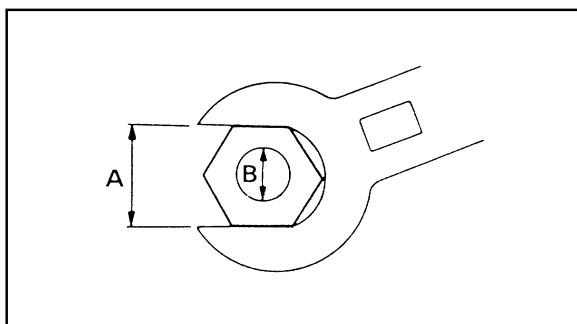

A: Distance between sides
B: Outer thread diameter

Unit	Denomination	Definition	Dimension
mm	Milimeter	10^{-3} meters	Length
cm	Centimeter	10^{-2} meters	Length
kg	Kilogram	10^3 grams	Weight
N	Newton	$1 \text{ kg} \times \text{m}/\text{sec}^2$	Force
Nm	Newton meter	$\text{N} \times \text{m}$	Tightening torque
m•kg	Kilogram-meter	$\text{m} \times \text{kg}$	Tightening torque
Pa	Pascal	N/m^2	Pressure
N/mm	Newton per millimeter	Nmm	Spring rating
L	Litre		Volumen
cm ³	Cbic centimeter		or capacity
R/min	Revolutions per minute		Engine revolution speed



**LUBRICATION POINTS AND TYPE OF LUBRICANT
ENGINE**

Lubrication point (name of the part)	Type of lubricant
Oil seal lips (all)	
“O” rings (all)	
Bearing seals	
Crankshaft bearings (left and central)	
Needle bearings (con rod)	
Primary shaft bearings	
Secondary shaft bearings	
Thrust cam bearing	
Crankshaft journals	
Rings, pins and pistons	
Drive shaft (water pump)	
Shaft (mixing pump)	
Clutch casing	
Thrust rod	
Thrust lever shaft	
Sliding gear (transmission)	
Free gear (transmission)	
Guide bar (transmission forks)	
Connection ball (shift pedal)	
Rotation points (shift pedal)	
Crankcase matching surfaces	Yamaha n° 4 adhesive



CHASSIS

Lubrication point (name of the part)	Type of lubricant
Ball bearings (steering column)	
Lips of the oil seals (front and rear wheels)	
Rotation points (brake pedal)	
Rotation points (side stand)	
Right end of handlebar	
End of the throttle cable (throttle twist grip)	
Rotation axle (clutch lever)	
Rotation axle (brake handle)	
Anchorage (rear shock)	
Swingarm	
Bearing (swingarm)	
Front wheel axle	
Rear wheel axle	
Bush (front wheel)	
Speedometer gear unit	



CABLE ROUTING

- ① DC-CDI
- ② Regulator-rectifier
- ③ Battery
- ④ Starter relay
- ⑤ Fuse box
- ⑥ Horn
- ⑦ Flasher relay
- ⑧ Neutral relay

- A Thread the horn cable through the support of the air filter casing
- B Thread the installation through the clamps or bridles on the frame
- C Thread the left-hand switch cable through the frame clamps
- D The mark for installing the system must coincide with the frame clamp

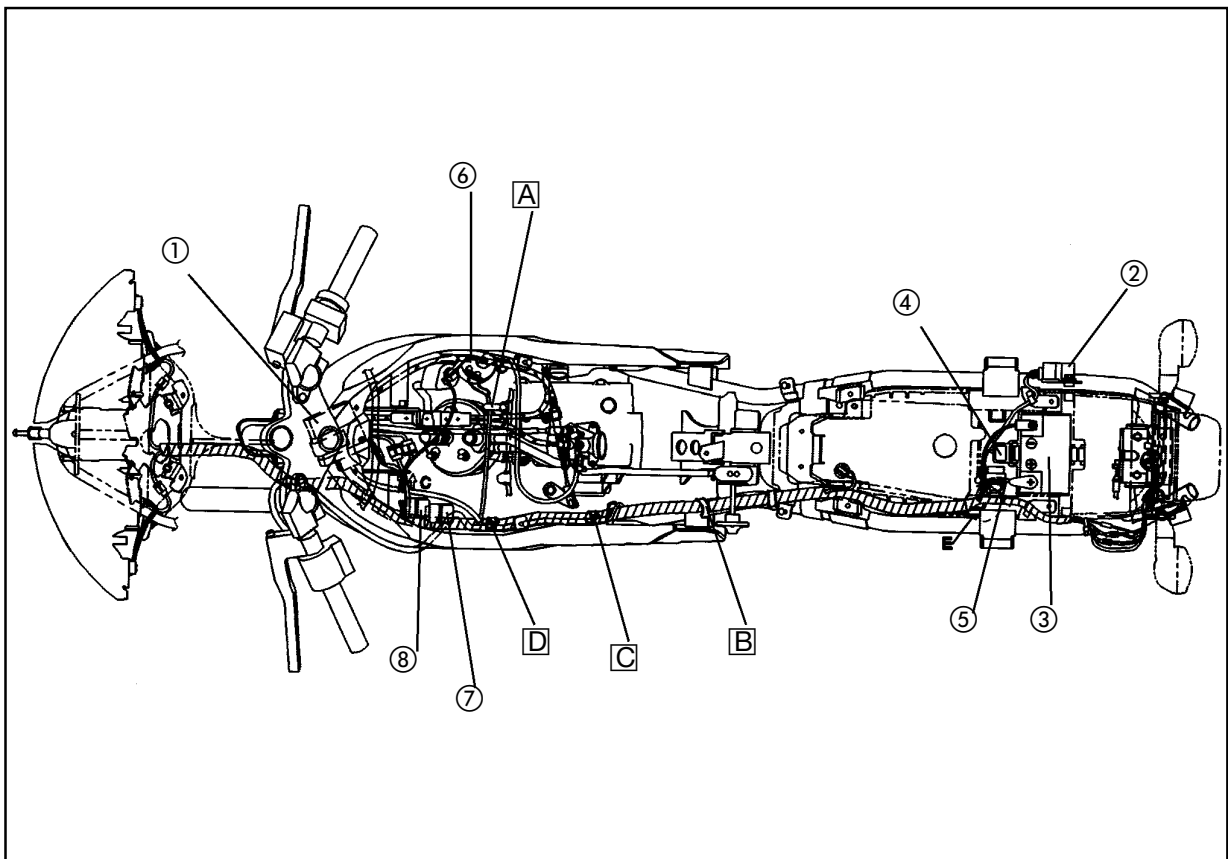

CABLE ROUTING

SPEC



- ① Speedometer connector
- ② Connector for headlight and front indicator lights
- ③ Connector for the speedometer sensor
- ④ Ground cable
- ⑤ Electrical installation
- ⑥ Tank overflow pipe
- ⑦ Carburettor overflow pipe
- ⑧ Engine breather pipe

- A Clamp the generator cable to the frame
- B Clamp the neutral switch cable to the frame
- C Thread the stand and neutral cables through the frame clamps
- D Thread the following cables through the frame clamp:
Rear brake switch
Stand switch
Neutral switch
Starter motor
- E Thread the cables described in point D plus the engine breather pipe through the frame clamp

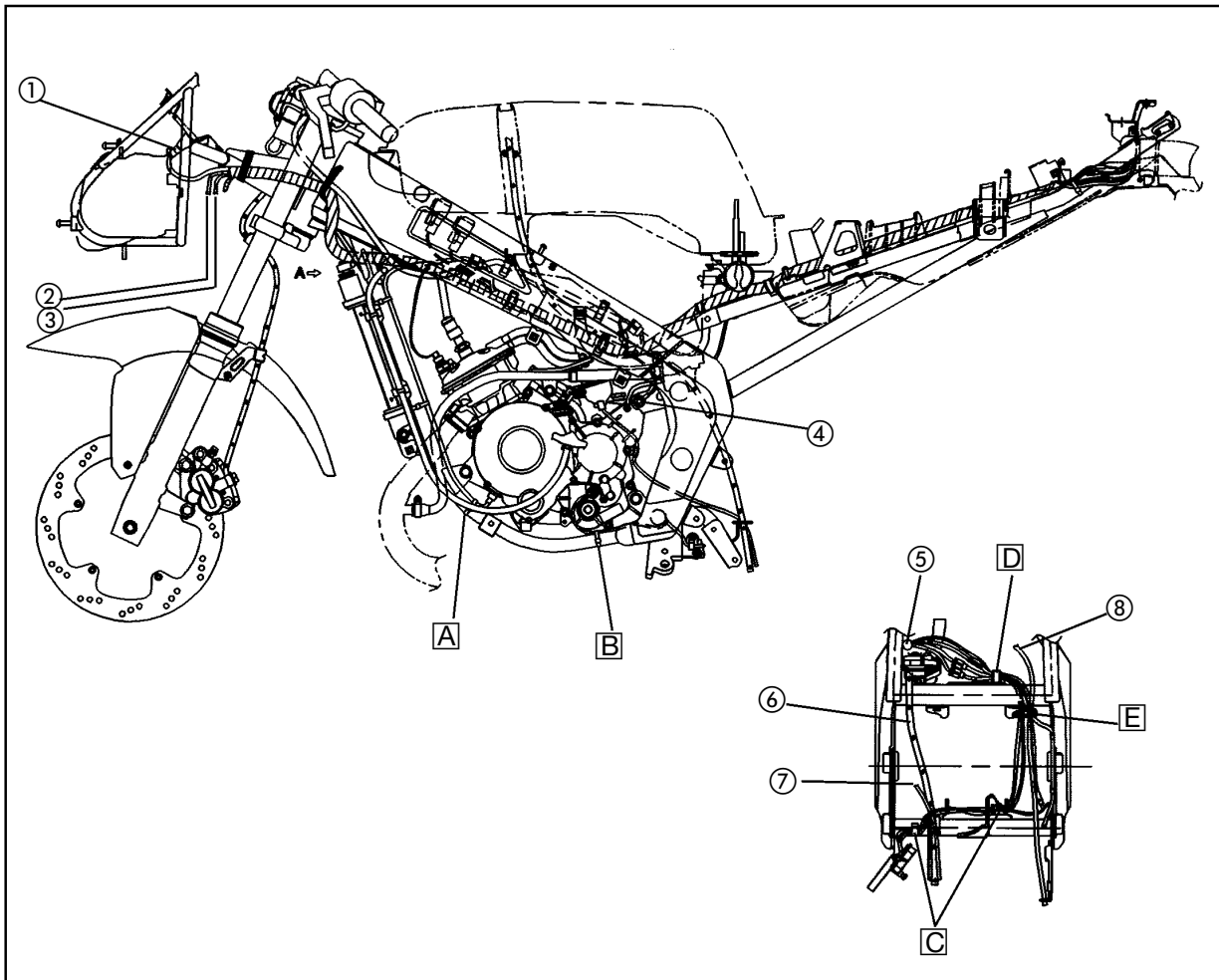



- A Thread the oil pipe through the frame clamps
- B Clamp the starter motor cable to the frame
- C Clamp the cable of the speedometer sensor through the rubber
- D Clamp the main switch cable, the head of the clamp must be at the bottom

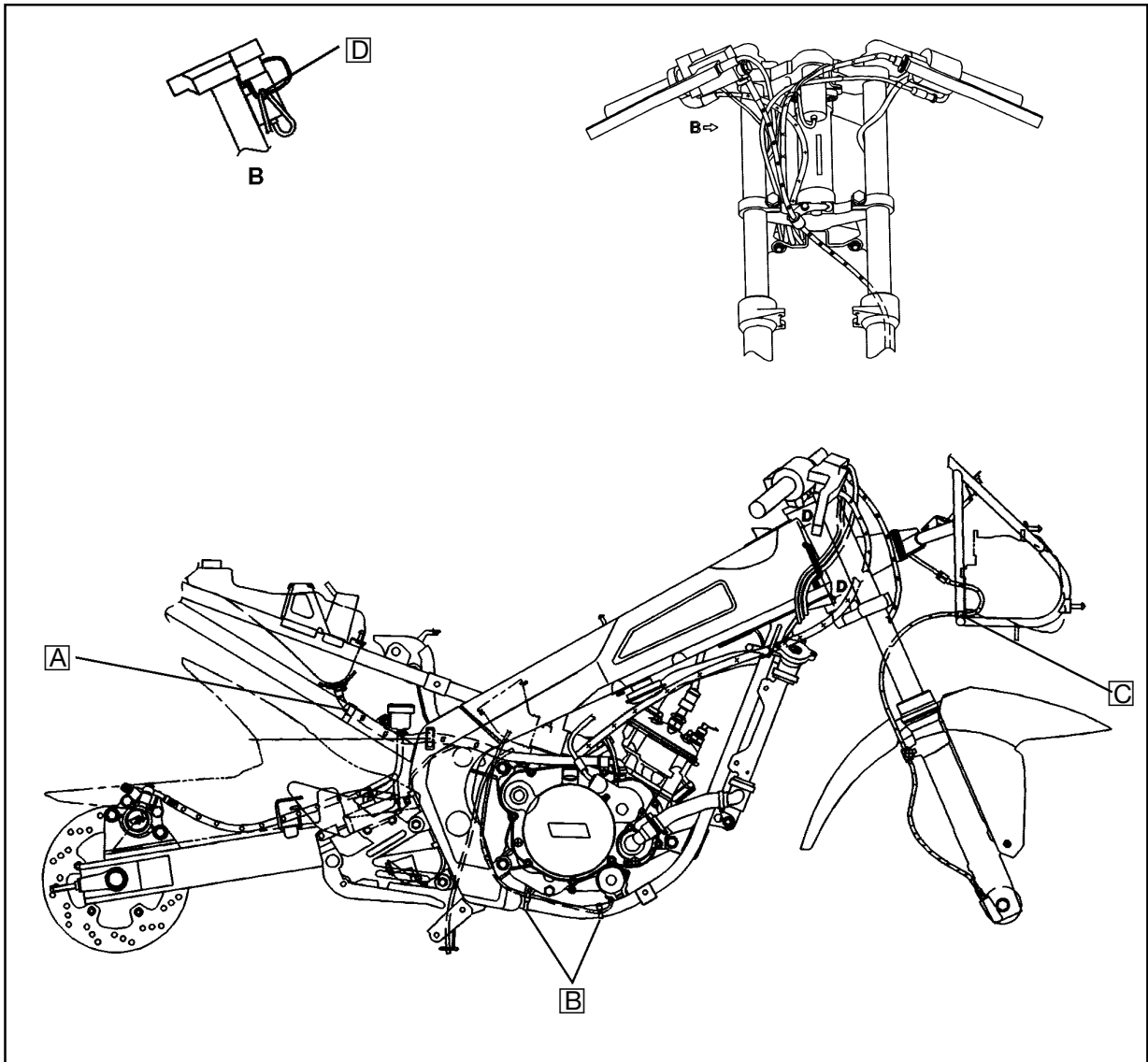



INSP



ADJ

3

CHAPTER 3

REGULAR INSPECTION AND ADJUSTMENTS

INTRODUCTION/REGULAR MAINTENANCE/LUBRICATION	3-1
SIDE COVERS	3-2
DISMANTLING	3-2
ASSEMBLY	3-2
ENGINE	3-3
ADJUSTING THE IDLING SPEED	3-3
ADJUSTING THE AUTOLUBE PUMP CABLE	3-4
ADJUSTING THE FREE PLAY OF THE THROTTLE CABLE	3-5
BLEEDING THE AUTOLUBE PUMP	3-6
ADJUSTING THE FREE PLAY OF THE STARTER CABLE	3-7
INSPECTING THE SPARK PLUG	3-7
INSPECTING THE ENGINE OIL LEVEL	3-9
INSPECTING THE TRANSMISSION OIL LEVEL	3-10
CHANGING THE TRANSMISSION OIL	3-10
ADJUSTING THE CLUTCH	3-11
CLEANING THE AIR FILTER	3-12
INSPECTING THE CARBURETTOR GASKET	3-14
INSPECTING THE FUEL HOSES	3-15
INSPECTING THE EXHAUST SYSTEM	3-16
INSPECTING THE LEVEL OF THE COOLANT	3-16
CHANGING THE COOLANT LIQUID	3-17
INSPECTING THE COOLING SYSTEM	3-21
CHASSIS	3-21
ADJUSTING THE REAR BRAKE	3-21
INSPECTING THE BRAKE LIQUID	3-21
BLEEDING THE AIR	3-22
INSPECTING THE BRAKE PADS	3-23
ADJUSTING THE BRAKE LIGHT SWITCH	3-24
INSPECTING THE BRAKE HOSES	3-24
ADJUSTING THE VOLTAGE OF THE TRANSMISSION CHAIN	3-25
LUBRICATING THE TRANSMISSION CHAIN	3-27
ADJUSTING THE STEERING	3-27
CHANGING THE FORK OIL	3-29
INSPECTING THE TYRES	3-31
INSPECTING THE WHEELS	3-32
INSPECTING THE CABLES	3-32
LUBRICATION	3-33
ELECTRICAL SYSTEM	3-34
INSPECTING THE BATTERY	3-34
INSPECTING THE FUSES	3-36
ADJUSTING THE HEADLIGHT BEAM	3-37
CHANGING THE HEADLIGHT BULB	3-37

REGULAR INSPECTION AND ADJUSTMENT

INTRODUCTION

This chapter contains all the information required to carry out the recommended services and adjustments. By following these preventive maintenance procedures you will ensure greater operating reliability for the vehicle and a longer useful life, considerably reducing the need for costly repairs. This information is applicable to both vehicles already in service and ones that are being prepared for sale. All service technicians should be completely familiar with this chapter.

No	ITEM	CHECK OR MAINTENANCE OPERATION	KILOMETRE CLOCK READING (x 1.000 km)					ANNUAL CHECK
			1	6	12	18	24	
1	* Petrol line	• Check to see if the petrol hose is cracked or damaged		√	√	√	√	√
2	Spark plug	• Check its condition • Clean and adjust space between electrodes • Change		√	√	√	√	
3	Air filter	*Clean • Change		√	√	√	√	
4	Clutch	• Check operation • Adjust	√	√	√	√	√	
5	Front brake	• Check operation, liquid level and to see if there are leaks on the vehicle • Check the brake pads	√	√	√	√	√	√
6	Rear brake	• Check operation, liquid level and to see if there are leaks on the vehicle • Check the brake pads	√	√	√	√	√	√
7	Brake tubes	*Check to see if these are cracked or damaged • Change		√	√	√	√	√
8	Wheels	• Check eccentricity and whether these are damaged		√	√	√	√	
9	Tyres	• Check the depth of the tread pattern and whether they are damaged • Change if necessary • Check the air pressure • Correct if necessary		√	√	√	√	√
10	Wheel bearings	• Check to see if the bearings are weak or damaged		√	√	√	√	
11	Swinging arm	• Check operation and to see if play is excessive • Lubricate with molybdenum bisulphide grease		√	√	√	√	
12	Transmission chain	• Check the chain tension • Check that the rear wheel is properly aligned • Clean and grease		Every 500 km and after washing the motorcycle or using in rain				
13	Steering bearings	• Check the bearing play and to see if the steering is stiff • Lubricate with lithium soap-based grease	√	√	√	√	√	
14	Chassis fixings	• Check that all the nuts, bolts and screws are properly tightened		√	√	√	√	√
15	Side stand	• Check operation • Grease		√	√	√	√	√
16	Stand switch	• Check operation	√	√	√	√	√	√
17	Front fork	• Check operation and whether oil is leaking		√	√	√	√	
18	Shock absorber assembly	• Check operation and to see if the shock absorber is leaking oil		√	√	√	√	
19	Carburettor	• Check the choke operation • Adjust the engine idling speed	√	√	√	√	√	√
20	Autolube pump	• Check operation • Bleed if necessary	√		√		√	√
21	Transmission oil	• Check the oil level • Change	√	√	√	√	√	√
22	Cooling system	• Check the coolant level and to see if there are leaks from the vehicle • Change	√	√	√	√	√	
23	Brake switches	• Check operation	√	√	√	√	√	√
24	Moving parts and cables	• Grease		√	√	√	√	√
25	Throttle twist grip box	• Check operation and play • Adjust the throttle cable play and to see if this is precise • Grease the throttle twist grip box and cable		√	√	√	√	√
26	Lights, signals and switches	• Check operation • Adjust the headlight beam	√	√	√	√	√	√

* We recommend these articles being serviced by an authorised Yamaha/MBK distributor.
** Apply medium weight bearing oil

NOTE:

- The air filter requires more frequent servicing when the vehicle is used in particularly wet or dusty areas.
- Hydraulic brake servicing
- Regularly check the brake liquid level and correct this as necessary
- Every two years change the internal components of the brake pump and calliper, as well as the brake liquid
- Change the brake tubes every four years and whenever these are cracked or damaged.

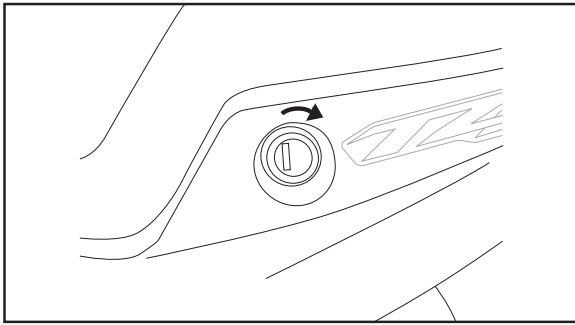

SIDE COVERS

DISMANTLING

1. Take off:
 - The seat

NOTE: _____

To open the seat lock, insert the key into this and turn clockwise

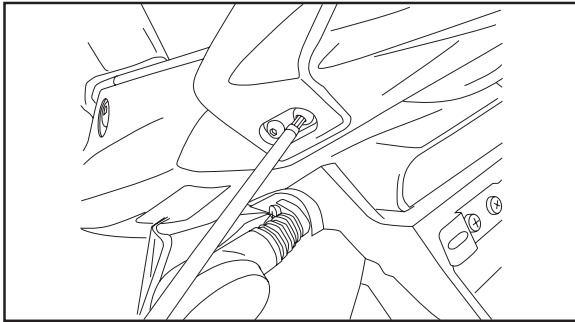

2. Dismantle:
 - The grip strap

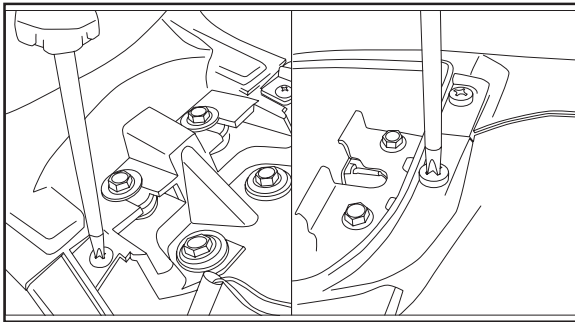

3. Remove:
 - Screws that secure each side cover and take these out

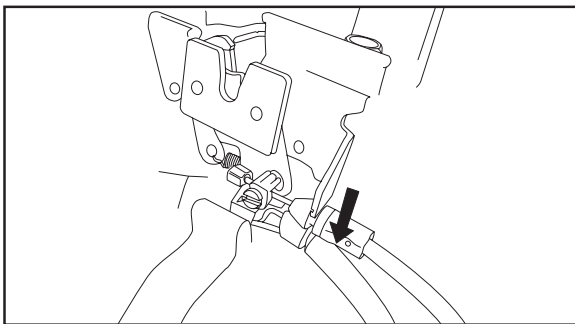

4. Release:
 - The seat locking cable

ASSEMBLY

Follow the same procedure as in “DISMANTLING” but inversely. Observe the following points:

1. Install:
 - The side covers (left and right-hand side), and tighten the screws.
 - The seat locking cable
2. Install:
 - The seat

NOTE: _____

Insert the projection of the seat into the recess made in the chassis for this purpose and press the seat downwards.

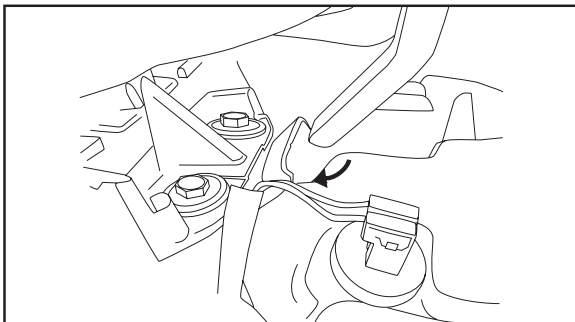

ADJUSTING THE IDLING SPEED

INSP
ADJ

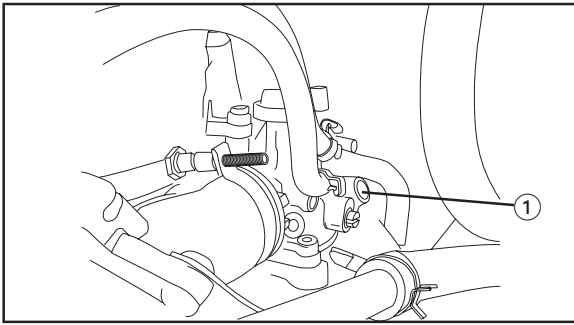

ADJUSTING THE IDLING SPEED

1. Tighten
 - The air screw ①
Tighten the screw until it gently abuts the end of its travel
2. Loosen:
 - The air screw ①
Partly unscrew this from its slightly abutting position



Turns the screw should be loosened:
2 1/8 turns

3. Start the engine up and let this warm up.
4. Connect:
 - The engine tachometer to the spark plug cable



Engine tachometer:
90890-03113

5. Check:
 - The engine idling speed
Out of specification → Adjust



Engine idling speed:
TZR50
1700 ~ 2000 r/min

ADJUSTING THE AUTOLUBE PUMP CABLE

INSP
ADJ

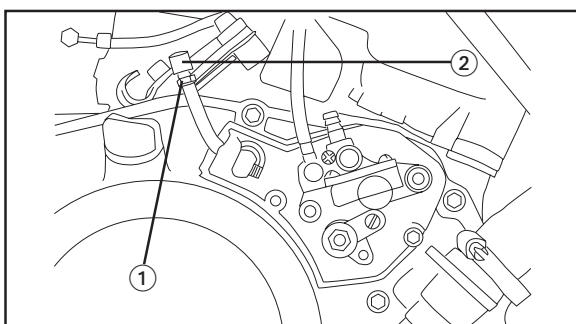
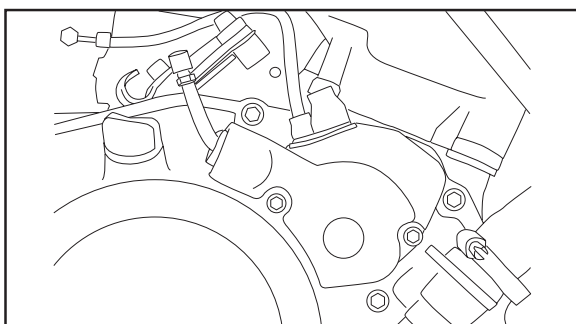

ADJUSTING THE AUTOLUBE PUMP CABLE

NOTE:

Before adjusting the automatic mixture pump cable, you must first adjust the free play of the throttle cable.

1. Remove:

- Cowlings
See the section on “FAIRING”, “DISMANTLING”
- The oil pump cover

2. Adjust:

- The throttle cable

3. Check:

- The free play while keeping the throttle in the idle position.
This is not adjusted → Adjust the pump cable

4. Adjust:

- The pump cable

Stages in the Adjustment:

- Loosen the locknut ①
- Tighten or loosen the tensor ② until getting the minimum play in operation
- Tighten the locknut

5. Check:

- Adjust the cable of the lubrication pump

ADJUST THE FREE PLAY OF THE THROTTLE CABLE

INSP
ADJ

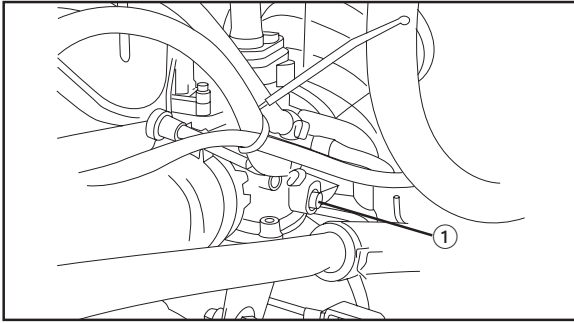

6. Adjust:
- The engine idling speed ①.

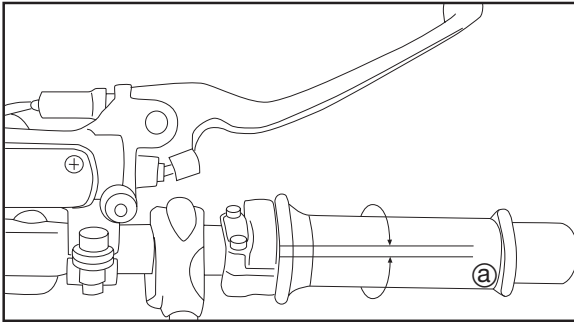

ADJUSTING THE FREE PLAY OF THE THROTTLE CABLE

1. Check:
- The free play (a) of the throttle cable
Out of specification → Adjust



Free play of throttle cable:
2 ~ 5 mm

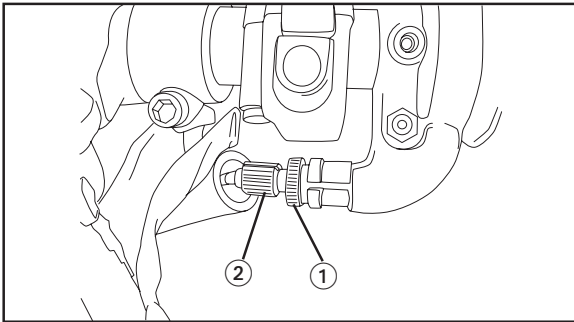

2. Adjust:
- Throttle cable free play

Adjustment steps:

- Loosen the locknut ①
- Loosen or tighten the tensor ② until you get the right free play

Tighten → Increases the free play

Loosen → Reduces the free play

- Loosen the locknut



BLEEDING THE AUTOLUBE PUMP

NOTE:

The automatic mixing pump and its hoses must be bled in the following cases:

- When taking a new motorcycle out of its packaging.
- Whenever the oil tank is completely emptied
- Whenever any part of the engine oil supply system is disconnected.

1. Remove:
 - The oil pump cover

2. Bleed the air:
 - From the pump casing and/or the oil hose

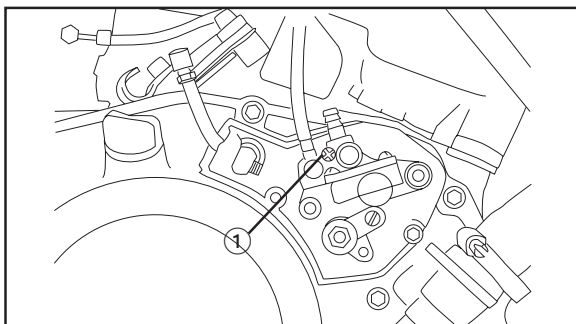

Bleeding air steps:

- Loosen the bleeding screw ①
- Start the engine up
- Let the oil out until the air bubbles disappear
- After the air bubbles have been completely removed, tighten the bleeding screw
- Stop the engine

NOTE:

Check the O ring of the bleeding screw and if any damage can be seen, change it for a new one

3. Install:
 - The oil pump cover



Screw (Autolube pump cover):
0.4 kg • m

ADJUSTING THE FREE PLAY OF THE CHOKE CABLE / INSPECTING THE SPARK PLUG

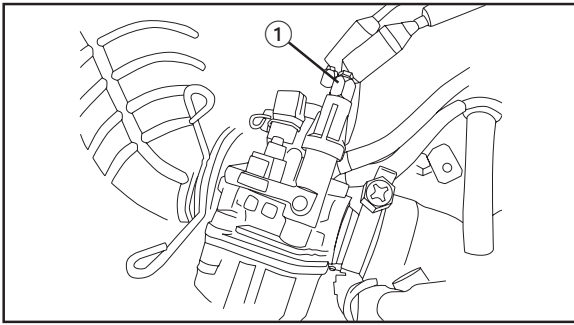

ADJUSTING THE FREE PLAY OF THE CHOKE CABLE / INSPECTING THE SPARK PLUG

1. Check
 - Free play of the choke cable ①
 - Out of specification → Adjust



Free play:
1.5 ~ 3.5 mm



Adjustment steps:

- Remove the right-hand side fairing
- Remove the tensor casing on the carburettor
- Turn the tensor inwards or outwards until getting the free play specified

Turning inwards → increases the play
Turning outwards → reduces the play

- Install the tensor casing



INSPECTING THE SPARK PLUG

1. Remove:
 - The spark plug
2. Inspect:
 - The type of spark plug
 - Incorrect → Change

Standard spark plug:
BR9ES

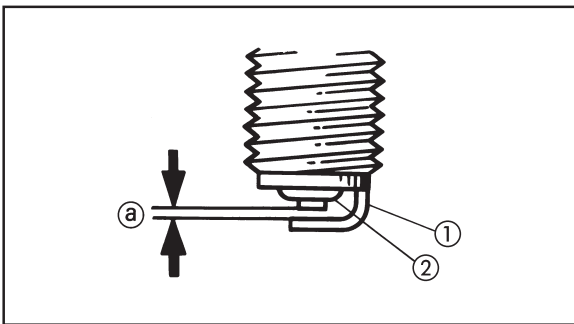

3. Inspect:
 - The electrode ①
 - Wear/damage → replace
 - The insulation ①
 - Abnormal colour → Replace
 - The normal colour is a medium-light beige
4. Clean the spark plug with a special tool for this or with a metal brush.
5. Measure:
 - The gap between electrodes (a)
 - Use a wire or feeler gauge
 - This does not match the value specified → Correct the distance.



Spark plug gap:
0.7 ~ 0.8 mm.

INSPECTING THE SPARK PLUG

INSP
ADJ



6. Tighten:
- The spark plug
Before installing a spark plug, clean the surfaces of the gasket and of the spark plug itself



Tightening torque:
23 Nm (2.3 m • kg)

NOTE: _____
Make the sparkplug finger-tight before tightening this to the specified degree.

INSPECTING THE ENGINE OIL LEVEL (MIXTURE)

1. Check:
 - The oil level
 Oil level low → top up with sufficient oil.



Recommended oil:
Yamaha 2 stroke oil
Capacity of the oil tank:
1.2 L

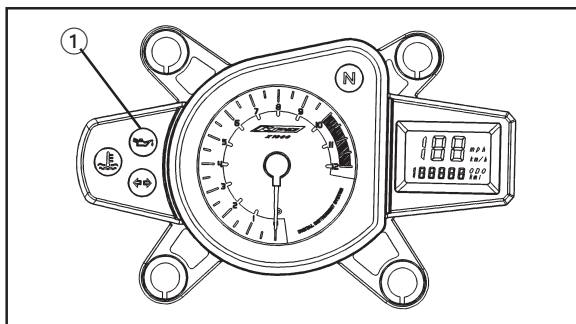
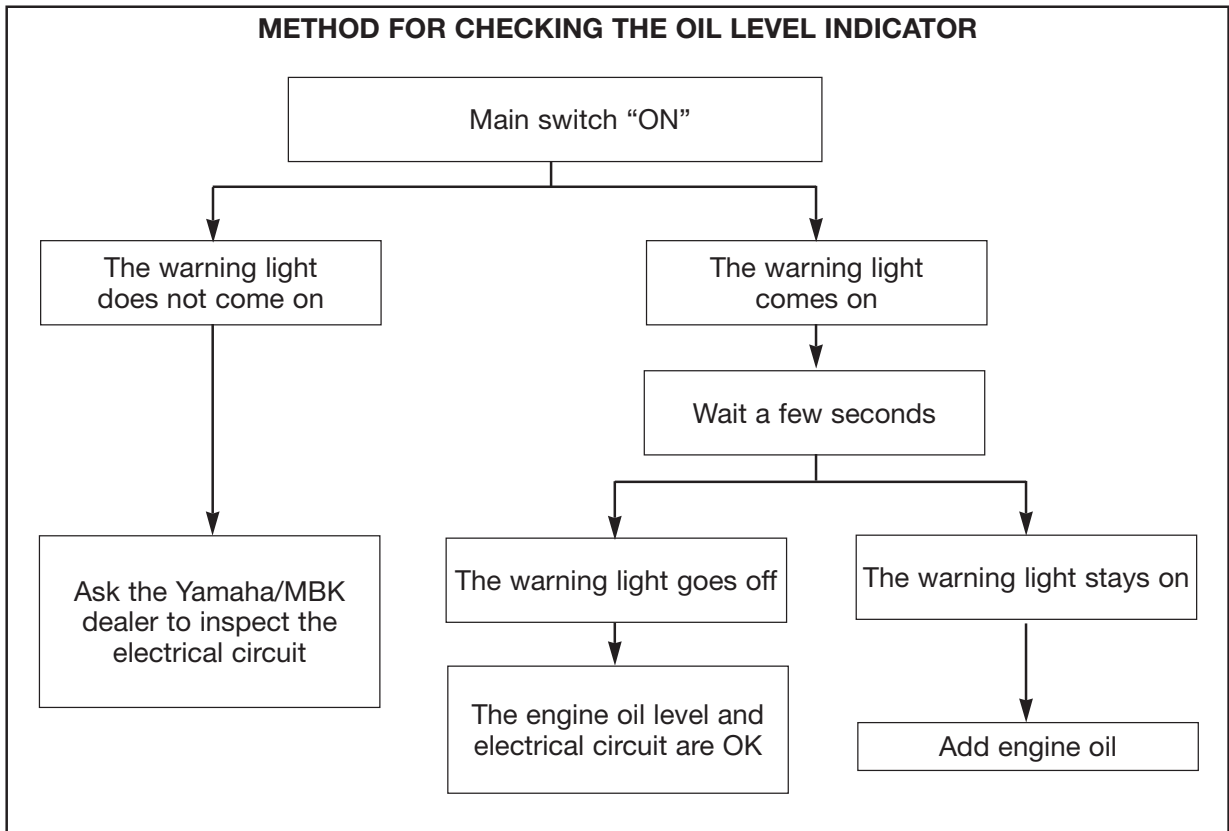

① "OIL" level indicator

CAUTION

Always use the same type of engine oil: Mixtures of different oils may give rise to detrimental chemical reactions and reduce efficiency.

INSPECTING THE OIL LEVEL OF THE TRANSMISSION/CHANGING THE TRANSMISSION OIL

INSP
ADJ

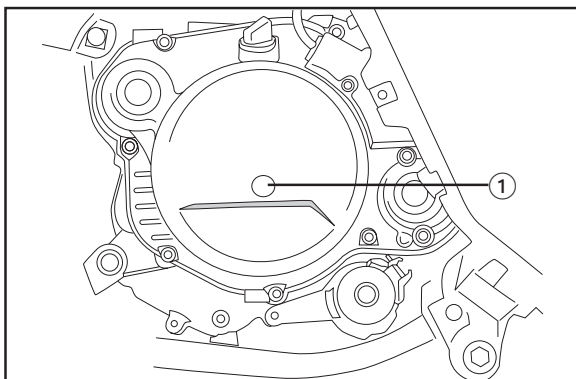

INSPECTING THE OIL LEVEL OF THE TRANSMISSION

1. Heat up the engine for one minute and then stop this
2. Keep the motorcycle horizontal and take out the level screw ①
3. Inspect:
 - The oil level
The oil level must be enough to overflow when taking out the level screw ①
Oil level too low → top up with sufficient oil to re-establish the right level.



Recommended oil:
SAE 10W 30 SE type engine oil.

CAUTION

- Do not add chemical additives. The transmission oil also lubricates the clutch and the additives could make it slip.
- Make sure that no foreign bodies get into the crankcase.

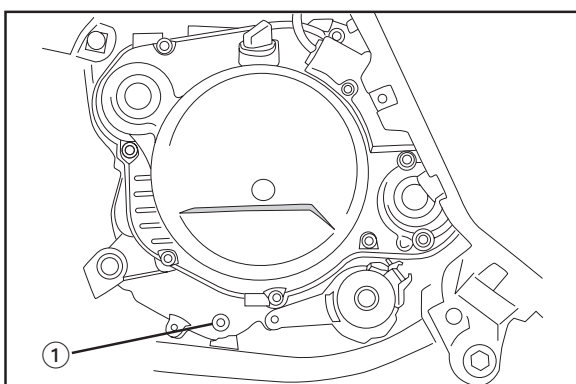

CHANGING THE TRANSMISSION OIL

1. Warm up the engine for a few minutes.
2. Place an open recipient under the engine
3. Remove:
 - The oil filler cap
 - Oil drain plug ①
4. Empty:
 - The transmission oil

NOTE:

Empty out the transmission oil when the motorcycle is completely vertical.

CHANGING THE TRANSMISSION OIL/ ADJUSTING THE CLUTCH

INSP
ADJ

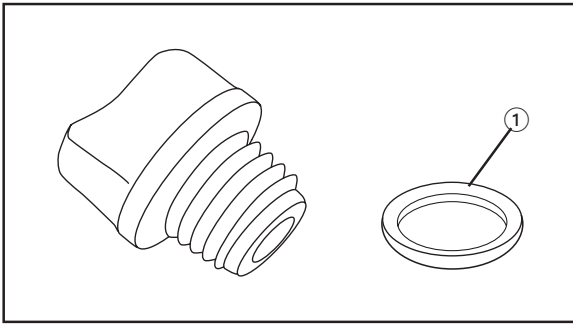

5. Inspect:
 - The O ring (of the oil filling cap) ①
Damage → replace
6. Install:
 - The drainage cap gasket

NOTE:

Always use a new gasket

- Oil drain plug



Oil draing plug:
1.7 kg • m

7. Fill up with:
 - The transmission oil



Recommended oil:
SAW/0W30 SE type engine oil
Total amount:
0.82 L
Regular oil change:
0.75 L

8. Install:
 - The O ring of the filling cap
 - The oil filler cap

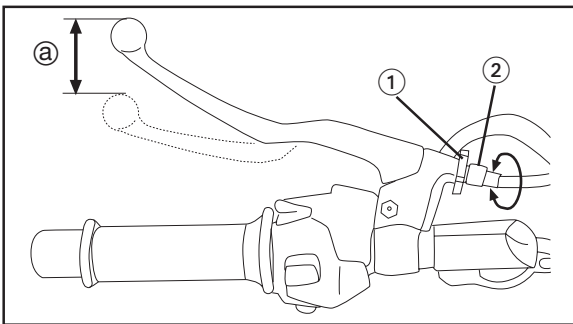

ADJUSTING THE CLUTCH

1. Check:
 - The clutch lever free play (a)
Out of specified value → Adjust



Free play:
10 ~ 15 mm

2. Adjust:
 - The free play of the clutch lever

Adjustment steps

- Loosen the locknut ①
- Turn the tensor ② in one direction or the other until getting the specified free play



Tightening → increases free play

Loosening → reduces free play

- Tighten the locknut

NOTE: _____

Normally, after properly adjusting the regulator for the length of the clutch cable (crankcase) the only adjustment required is to keep the right free play by means of the clutch cable tensor (handlebar lever).

NOTE: _____

The procedure described will enable you to get the maximum free play of the clutch cable to be able to adjust the clutch action mechanism properly.

See the section “DISMANTLING THE ENGINE - ASSEMBLING AND ADJUSTING THE ENGINE” in CHAPTER 4.

CLEANING THE AIR FILTER

1. Remove:
 - The seat
 - The side covers (left and right-hand)
See the section on “SIDE COVERS - DISMANTLING”

2. Dismantle:
 - The fuel tank
See the section “REMOVING THE ENGINE” in CHAPTER 4.

CLEANING THE AIR FILTER

INSP
ADJ

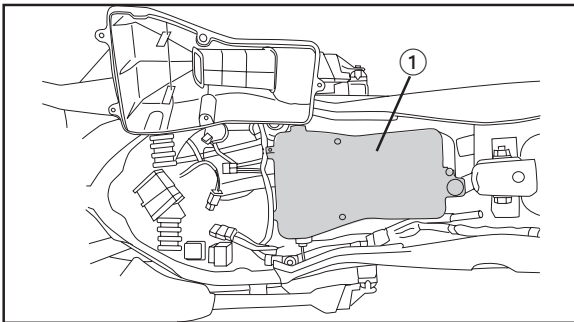
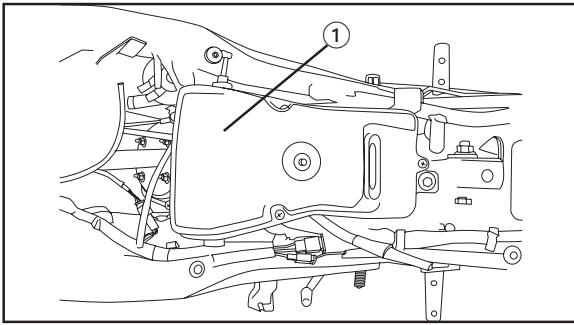

3. Remove:
 - The cover of the air filter case ①

4. Take out:
 - The filter element ①

CAUTION

Never let the engine run without the filter element of the air filter as unfiltered air would get into the engine, which would lead to early wear and possible motor faults. Apart from this, running without the filter element affects the tuning of the carburation, thus reducing the efficiency and possibly making the engine overheat.

5. Inspect:
 - The filter element
 - Damage → replace

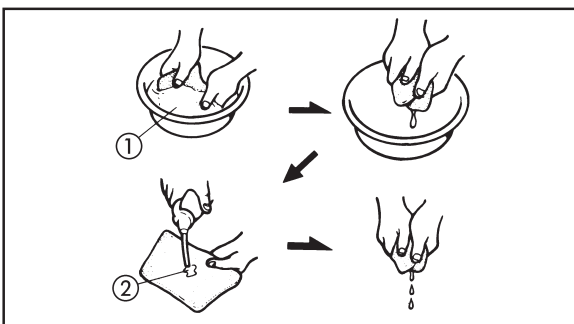

6. Clean:
 - The air filter element

Cleaning steps:

- Wash the element carefully but thoroughly, with solvent ①

⚠ WARNING

Never use solvent with an excessively low flash point, like petrol, to clean the filter element. This kind of solvents may lead to fires or explosions.

- Drain off the surplus solvent and leave it to dry

CAUTION

Do not wring out the filter element to drain this



- Apply SAE 10 W30 engine oil ②
- Drain off any excess oil

NOTE: _____

The element should be damp but not soaked.

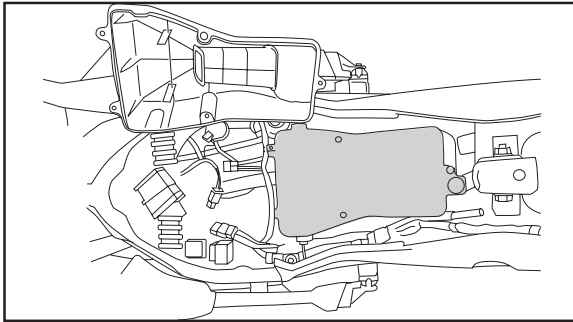

7. Install:
- The filter element of the air filter

CAUTION _____

Make sure that the edge of the element fits in the corresponding slot of the filter box

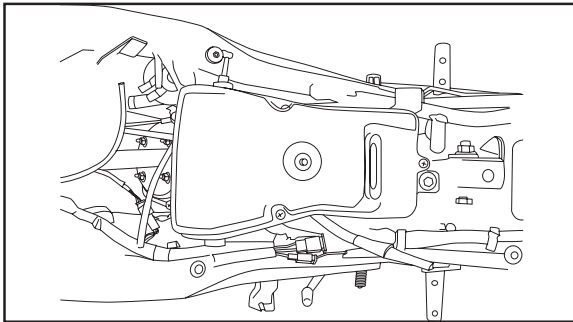

8. Install:
- Air filter case cover
 - The fuel tank

9. Install:
- The side covers (left and right-hand)
 - The tank
 - The seat
- See the section on "SIDE COVERS - ASSEMBLY"

INSPECTING THE CARBURETTOR GASKET

1. Dismantle:
- The seat
 - The side covers (left and right hand)
- See the section on "SIDE COVERS - DISMANTLING"

2. Dismantle:
- The fuel tank
 - The air filter case
- See the section on "REMOVING THE ENGINE" in CHAPTER 4.

INSPECTING THE CARBURETTOR GASKET / INSPECTING THE FUEL HOSES

INSP
ADJ

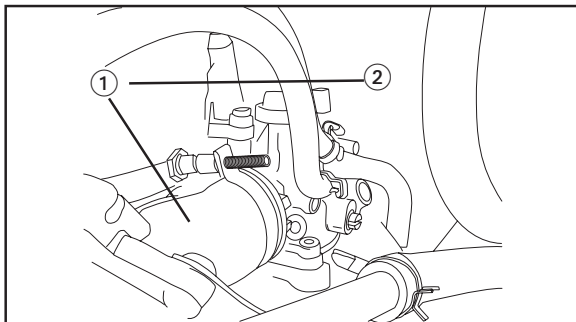

3. Inspect:
 - The carburettor joint ①Cracks/damage → Replace
See the section on “CARBURETTOR” -
DISMANTLING THE ENGINE in CHAP-
TER 4

4. Install:
 - The air filter case
 - The fuel tank
5. Install:
 - The side covers (left and right-hand)
 - The seatSee the section on “SIDE COVERS -
ASSEMBLY”

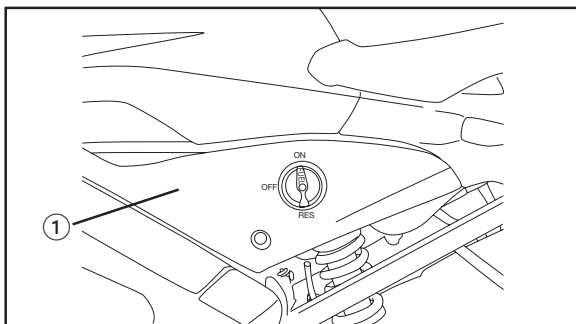

INSPECTING THE FUEL HOSES

1. Dismantle:
 - The seat
 - The small left-hand side cover ①

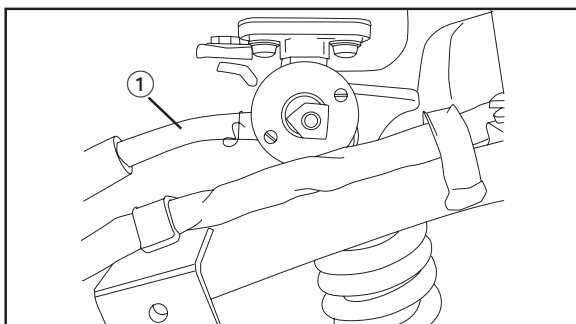

2. Inspect:
 - The fuel inlet pipe ①Cracks / Damage → Replace
3. Install:
 - The small left-hand side cover
 - The seat

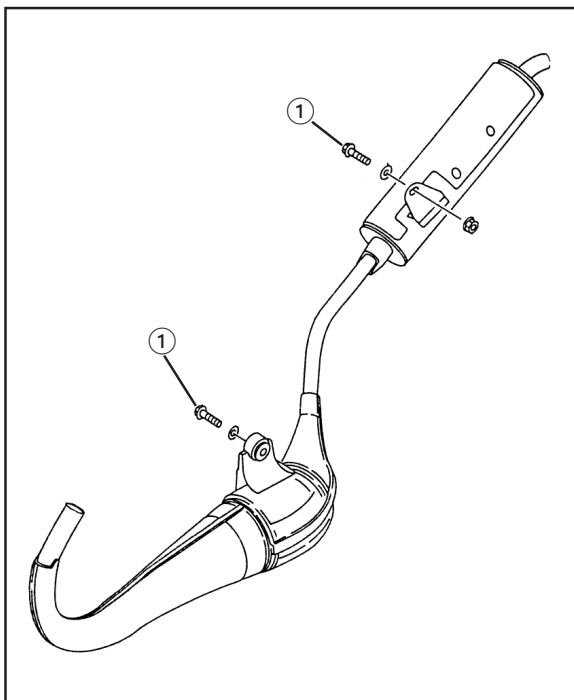

INSPECTING THE EXHAUST SYSTEM

1. Inspect:
 - The exhaust pipe
 - The muffler
 Cracks / Damage → Replace gaskets ①
 Leakages of exhaust gases → Replace

Replacement steps:

Dismantle the exhaust assembly
 Install a new exhaust assembly



Screw ①:
1.5 kg • m



Screw ②:
2.3 kg • m

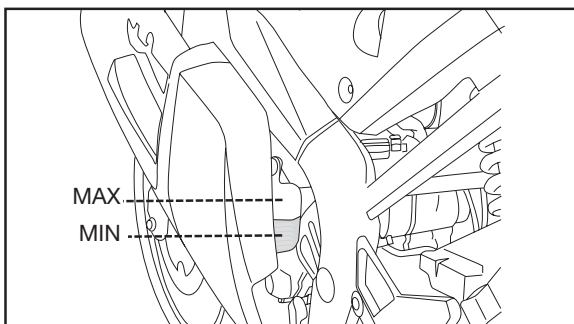

INSPECTING THE COOLANT LEVEL

1. Place the motorcycle on a level surface.
2. Inspect:
 - The level of coolant
 - The level of coolant is under the minimum mark
 - Remove panel ①
 - Add water (for the cooling circuit)

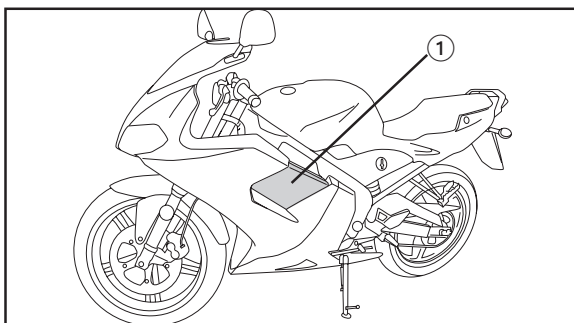



NOTE:

To check the level of coolant, place the motorcycle in a vertical position; if it leans to one side, however little this may be, the readings may be false.

CAUTION

Water with impurities is damaging for the engine components. You can use boiled or distilled water

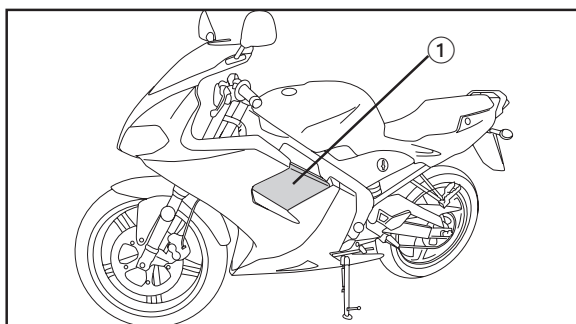
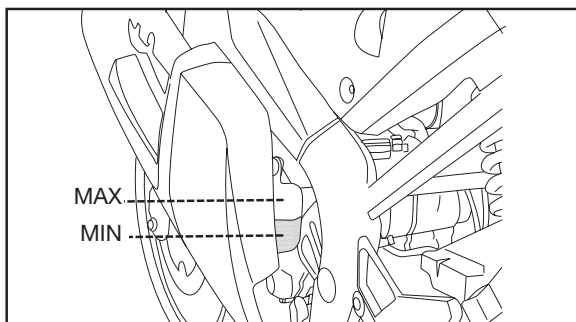

3. Add:

- Water to the cooling circuit
Until the level of liquid reaches the "MAX" maximum mark



Capacity of the reservoir tank:

Total:

0.71 L

From the "MIN" minimum mark to
the "MAX" maximum mark:

0.18 L

4. Install:

- Panel ①

CHANGING THE COOLANT

⚠ WARNING

Do not remove the radiator cap while this and the engine are hot. Hot vapour and liquid could emerge with consequent danger of serious injury. When the engine has cooled off, open the radiator tap as follows: place a thick cloth, for example a towel, over the cap and turn this as far as it will go, slowly, anti-clockwise. This procedure will let any residual pressure release. When the whistling sound has stopped, tighten the cap downwards making it turn at the same time anti-clockwise, and remove it.

CHANGING THE COOLANT

INSP
ADJ

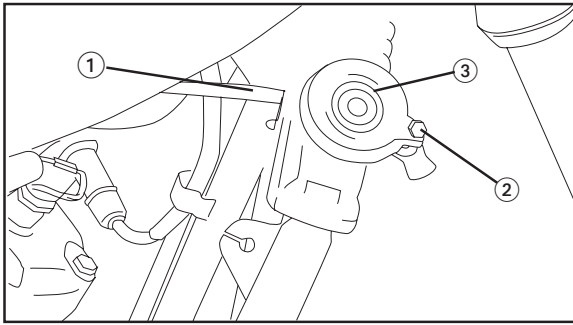

1. Disconnect:
 - The breather pipe ①
2. Drain the coolant reservoir tank.
3. Remove:
 - The securing screw ②
 - The radiator cap ③

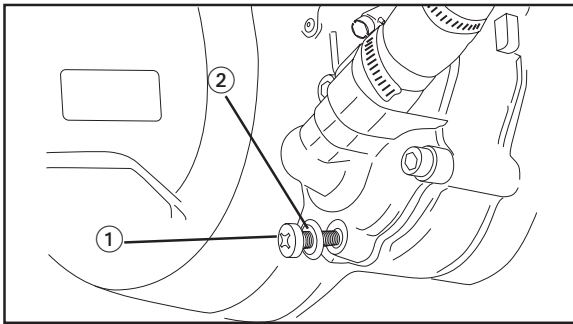

4. Remove:
 - The drainage screw ①
5. Drain:
 - The coolant

NOTE:

Empty out the coolant with the motorcycle slightly tilted to the right.

6. Install:
 - The gasket (new) ②
 - The drainage screw ①



Drainage screw:
0.5 kg • m

CAUTION

- Always install a new gasket
- Install the gasket as shown in the illustration

7. Install:
 - The radiator
 - The engine



Coolant recommended:
high quality ethylene glycol anti-freeze, containing corrosion inhibitors for aluminium engines.
Coolant and distilled water.
Mixing proportion:
50 % / 50 %
Total amount:
0.7 L
Capacity of reservoir tank:
0.47 L

Notes on handling the coolant liquid:
The coolant is harmful and should thus be handled with special care.

⚠ WARNING

- If the coolant liquid gets in someone's eyes, wash these out thoroughly with water and see a doctor.
- If the coolant splashes clothing wash this immediately with water and then with soap.
- If coolant is swallowed make the person affected vomit immediately and see a doctor.

CAUTION

- Water with minerals is damaging for the engine components: use boiled or distilled water.
- Do not use water containing impurities or oil.
- Take care that the coolant does not splash any painted surface. If there is any splashing, wash the surfaces with water.

CHANGING THE COOLANT

INSP
ADJ

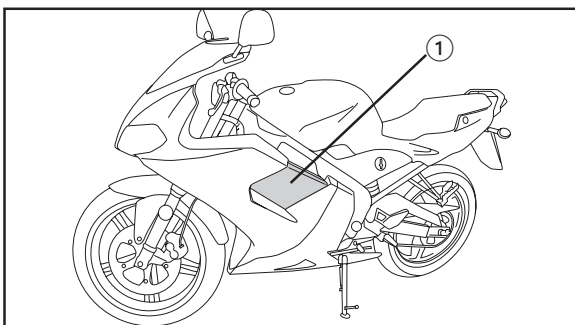
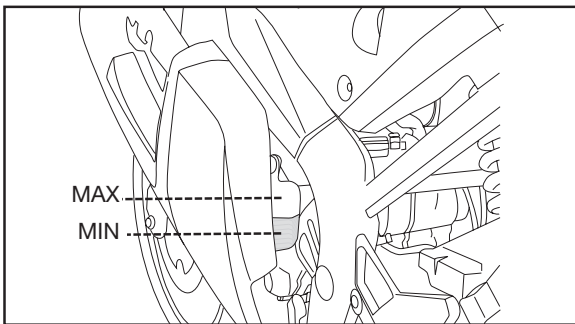
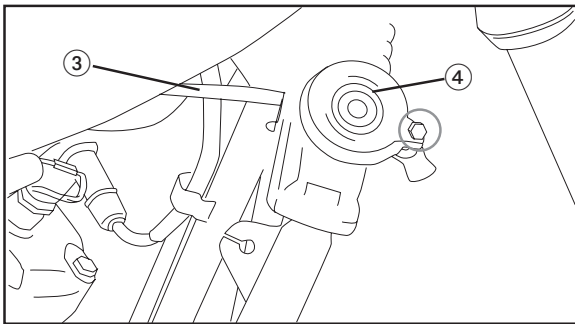
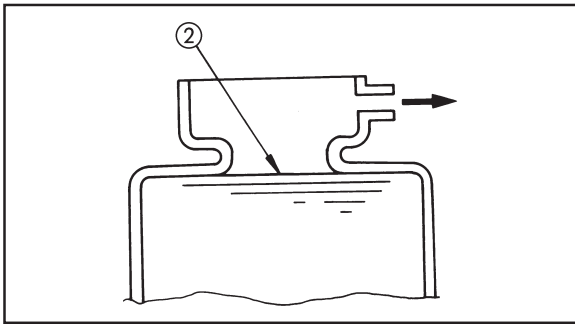
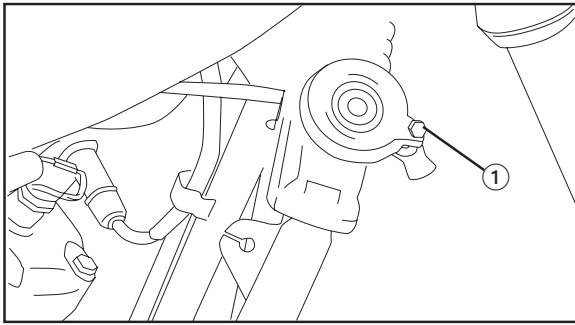

Stages in filling with coolant:

- Remove the screw of the radiator cap ①
- Pour the coolant into the radiator



Drainage screw:
0.5 kg • m

- Pour the coolant into the radiator until the level specified is reached ②

- Connect the breather pipe ③
- Install the radiator cap ④

- Fill the reservoir tank with coolant until the level reaches the "MAX" maximum mark
- Start the engine and leave it to warm up
- Stop the engine and check the coolant liquid level

NOTE: _____

Wait a few minutes until the coolant liquid level has stabilised, before making the check.

8. Install:
- The panel ①

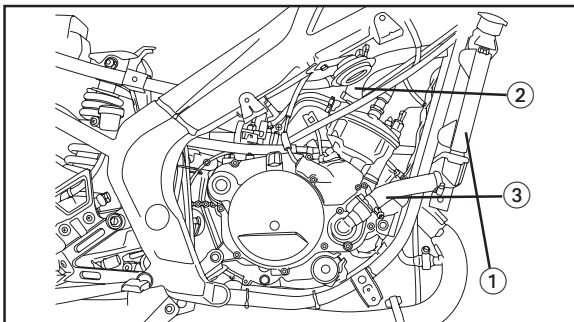

INSPECTING THE COOLING SYSTEM

1. Inspect:
 - The radiator ①
 - The inlet hose ②
 - The outlet hose ③Cracks / Damage → Replace
See the section on “COOLING SYSTEM”
in CHAPTER 5

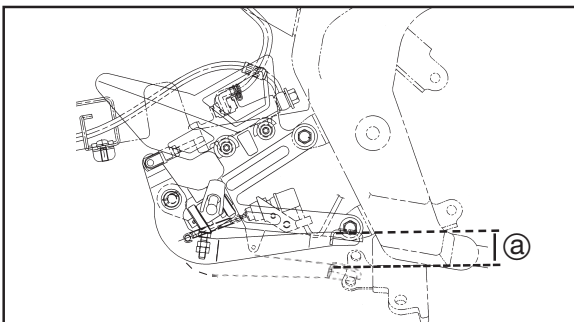

ADJUSTING THE REAR BRAKE

Adjusting the free play of the rear brake pedal

1. Check:
 - The free play of the brake pedal (a)Out of specification → Adjust



**Free play of the brake pedal:
10 ~ 15 mm**

2. Adjust
 - Free play of the rear brake pedal

Adjustment steps

- Turn the adjustment device located in the lever pusher by means of the nut and lock-nut system

Tighten → Increases the free play of the pedal

Loosen → Reduces the free play of the pedal

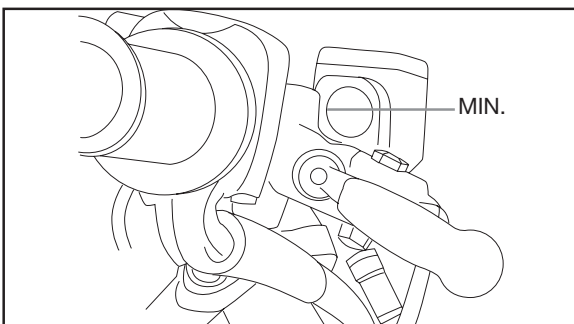

INSPECTING THE BRAKE LIQUID

1. Place the motorcycle on a flat surface
2. Check:
3. Brake liquid level
 - The level is under the “MIN” mark → fill up



**Brake liquid recommended:
DOT n° 4**



NOTE:

- Place the motorcycle vertically to check the level of the brake liquid
- When checking the front brake liquid level, make sure that the top side of the master cylinder is horizontal, moving the handlebar if necessary

CAUTION

The brake liquid can erode the painted surfaces and the plastic parts: always immediately clean any liquid spilt.

⚠ WARNING

- Use only brake liquid of the specified quality; otherwise the rubber seals might deteriorate, which would give rise to leakages and a reduction in the effectiveness of the brakes
- Fill up again with liquid of the same type; the mixture of different liquids might give rise to detrimental chemical reactions and a consequent drop in efficiency. Take care that water does not get into the master cylinder when filling up.
- Water makes the boiling point of the liquid drop considerably and may give rise to an obstruction through vapour.

BLEEDING THE AIR

⚠ WARNING

The brake system must be bled in the following cases:

- When the system has been dismantled
- When a brake sleeve has been loosened or dismantled
- When the brake liquid level is too low
- When the brake operation is faulty
- There may be a dangerous drop in braking capacity if the system has not been properly bled.

1. Bleed:
 - The brake liquid

BLEEDING THE AIR / INSPECTING THE BRAKE PADS

INSP
ADJ

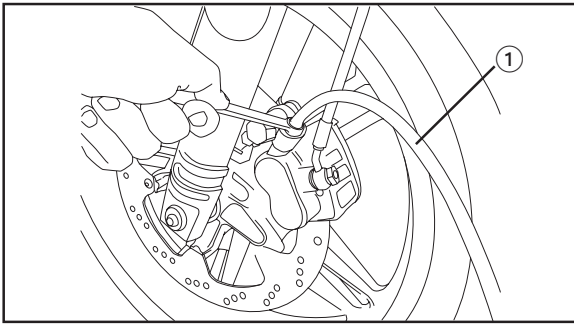

Bleeding air steps:

- a. Add brake liquid of the appropriate type to the tank
- b. Install the diaphragm. Take care not to spill the liquid and for the tank not to overflow
- c. Connect the transparent plastic tube ① firmly to the calliper bleeding screw
- d. Install the other end of the tube into a recipient
- e. Activate the brake lever slowly several times
- f. Pull the handle. Keep it in this position.
- g. Loosen the bleed screw and let the lever move to the end of its travel.
- h. Tighten the drain screw when the lever has reached the limit; then release the lever.



Bleed screw:
0.6 kg • m

- i. Repeat stages (e) to (h) until any air bubbles have disappeared from the system.

NOTE:

If you have trouble bleeding the system, you might need to leave all the brake system liquid to stand for a few hours. Repeat the bleeding procedure when the tiny bubbles contained in the system have disappeared.

- j. Add brake liquid up to the level line marked on the tank.

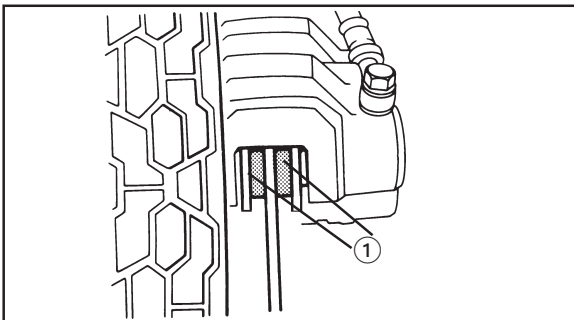

INSPECTING THE BRAKE PADS

1. Push the brake lever.
2. Inspect:
 - The brake pads ①If the thickness of the pads is under 0.5 mm → Replace the set of brake pads. See the section on “CHANGING THE BRAKE PADS” in CHAPTER 7.

ADJUSTING THE BRAKE LIGHT SWITCH / INSPECTING THE BRAKE HOSES

INSP
ADJ



ADJUSTING THE BRAKE LIGHT SWITCH

NOTE:

The brake light switch is activated by the movement of the brake pedal. This is properly adjusted when the brake light comes on immediately before the brake starts to work.

1. Hold the switch body still with your hand so that this does not rotate and turn the adjustment nut in direction (b).

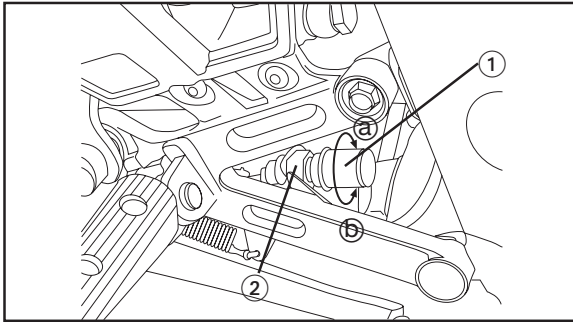

CAUTION

After adjusting make sure that this comes on.

INSPECTING THE BRAKE HOSES

1. Inspect:
 - The brake hoses
Cracks/Wear/Damage → Replace



ADJUSTING THE DRIVE CHAIN SLACK

NOTE:

Before checking and/or adjusting the chain, make the rear wheel turn several times and check the tension at several points until you find the place where this is most tense. Check and /or adjust the chain with the rear wheel in this position of maximum tension.

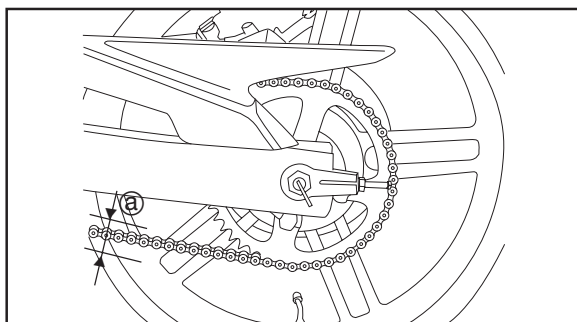

1. Place the motorcycle on a flat surface and in vertical position.

NOTE:

Both wheels must be supported on the ground and with no rider seated.

2. Check:
 - The drive chain slack
 - (a) This does not match the specified value → Adjust



Chain (a) slack:
20 ~ 25 mm

with the rear wheel resting on the ground.

3. Adjust:
 - The drive chain slack

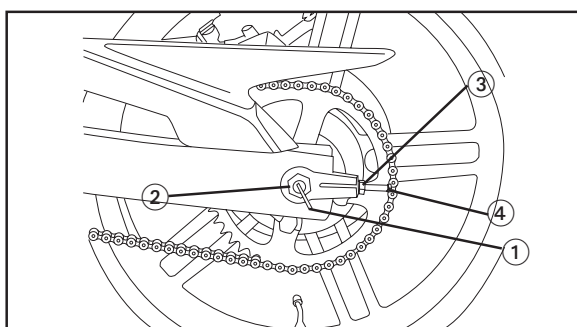

Adjustment steps

CAUTION

If the chain is too taut the loads on the engine and other vital components increase excessively, so keep the chain slack within the limits specified.

- Remove the pin (1)
- Loosen the axle nut 2 and the locknut (3)
- Turn the tensor 4 in one direction or the other until the tension specified is obtained.

Tighten → Increases the free play

Loosen → Reduces the free play

NOTE:

Turn both tensors to exactly the same extent, to keep the axle properly aligned. (There are marks on both sides of the swingarm and on each chain tensor: use these to make sure that the alignment is correct.)

ADJUSTING THE DRIVE CHAIN SLACK

INSP
ADJ

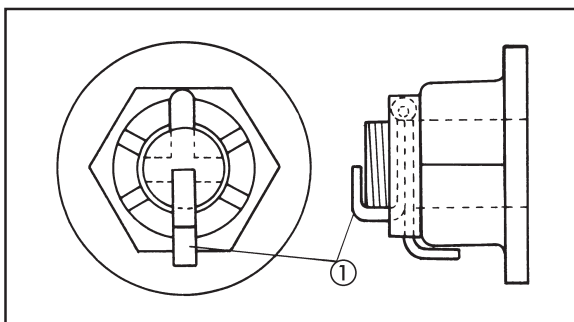
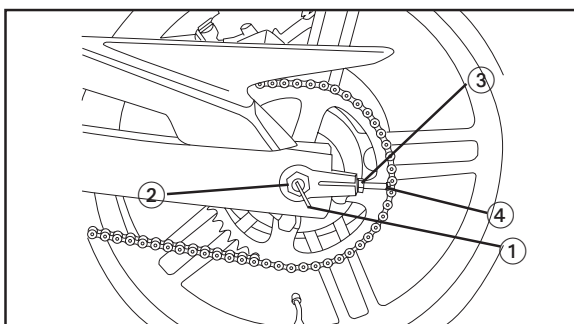

- Tighten the axle nut (2)



Axle nut:
85 Nm (8.5 kg • m)

NOTE: _____

Tighten the axle nut while keeping the chain taut with your hand so as to keep the proper play of the chain.

- Tighten the tensor (4)



Tensor:
0.5 kg • m

- Tighten the locknut (3)



Locknut:
1.5 kg • m

- Tighten the securing screw of the brake calliper
- Install the pin (1) (use a new one)
- Adjust the free play of the brake pedal
See "ADJUSTING THE REAR BRAKE"

NOTE: _____

Do not loosen the axle nut after tightening to the specified torque. If the nut slot does not coincide with the hole for the pin found in the axle, line both of these up by tightening the nut.

⚠ WARNING _____

- Always use a new pin for the axle nut
- Check the operation of the brake light after adjusting the rear brake.



LUBRICATING THE DRIVE CHAIN

The chain consists of a large number of parts that work in constant contact with each other. If it does not get proper maintenance it will wear quickly. This is why one should acquire the habit of checking the chain regularly. These checks are particularly necessary when driving through dusty areas.

1. Use a chain lubricant in aerosol form. First remove any dirt and mud from the chain with a brush or cloth; then spray the lubricant between both rows of side plates, above all the central rollers.
2. To clean the chain, take this off the machine, submerge it in solvent and get rid of all the dirt possible. Take the chain out of the solvent and dry it. Immediately lubricate this to prevent it from rusting.



**Recommended lubricant:
SAE 10W30 SE type**

ADJUSTING THE STEERING

Inspecting the steering head

⚠ WARNING

Stand the motorcycle in a safe place to avoid any danger of it falling over

1. Lift the front wheel, placing a suitable support under the engine.
2. Check:
 - The bearings of the steering assembly. Twist grip the ends of the fork arms and gently rock the assembly forwards and backwards.
Play → Adjust the steering head

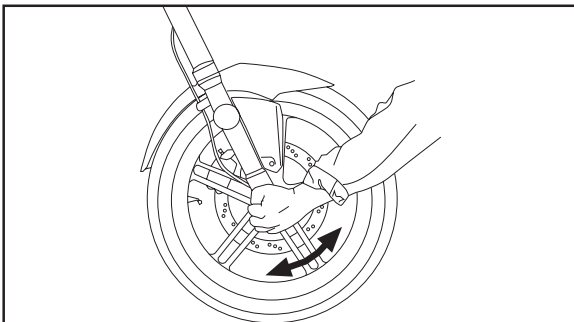

ADJUSTING THE STEERING

INSP
ADJ

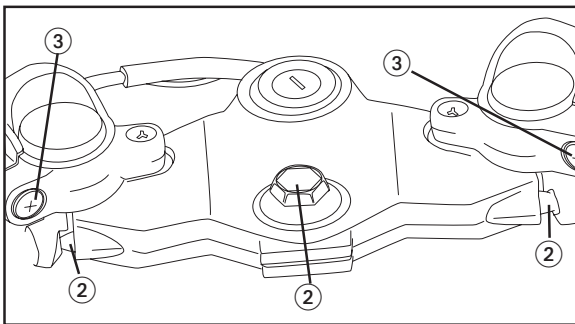
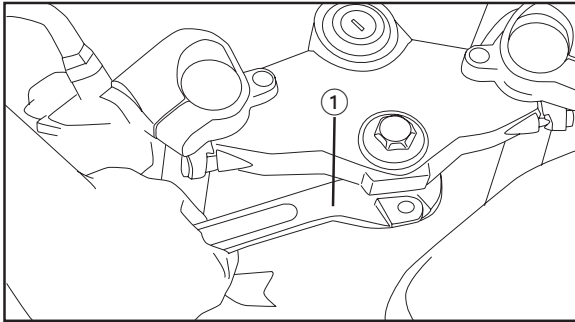
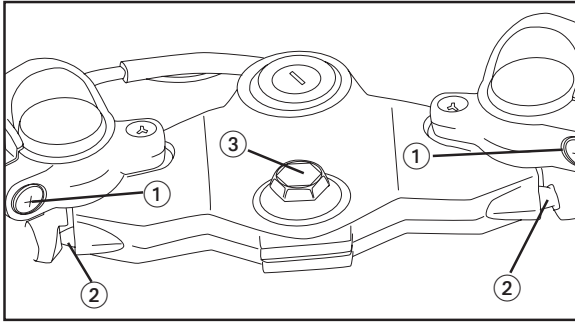

Adjusting the steering head

- Adjust:
 - The steering head

Adjustment steps:

- Loosen the screw ① of the handlebar clamp, the screw ② of the upper steering shank and the screw ③ of the steering shaft.
- Take off the fuel tank.
- Tighten the ring nut with the wrench designed for this ①.



Wrench for ring nut:
90890 - 01403

NOTE:

Apply the torque wrench to the ring nut wrench so that both form a right angle.



Ring nut (initial tightening):
2.0 kg • m

- Loosen the ring nut one turn.
- Retighten the ring nut using the special wrench for this.

⚠ WARNING

Do not tighten excessively



Ring nut (final tightening):
0.6 kg • m

- Tighten screw ① (steering shaft), screw ② (upper shank) and screw ③ (handlebar).



Screw (steering shaft):
5.6 kg • m
Clamp screw (upper shank):
2.2 kg • m
Clamp screw (handlebar):
2.2 kg • m



CHANGING THE FORK OIL

⚠ WARNING

- Leaks of oil from the fork may give rise to drops in stability and reduce driving safety. Any problems found must be corrected before using the motorcycle.
- Stand the motorcycle up firmly to avoid any danger of it falling over.

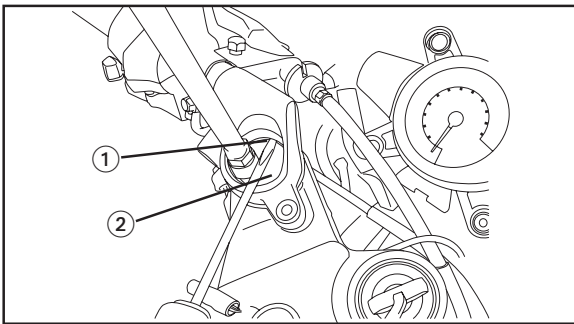
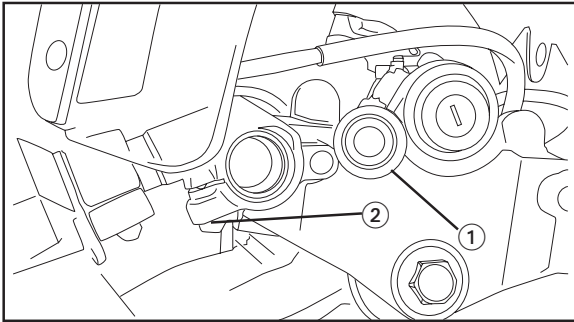

1. Lift up the front wheel placing a suitable support under the engine.
2. Remove:
 - The rubber cover ①
3. Loosen:
 - The clamp screw (handlebar) ②
4. Remove:
 - The circlip ①
 - The plug ②

NOTE:

Press the plug ② with an appropriate bar and remove the circlip 1 with a fine screwdriver.

5. Remove:
 - Forks
6. Drain:
 - Oil

⚠ WARNING

Do not let the oil get in touch with the components of the disc brake. If oil gets on the brake components remove this before using the motorcycle. Oil reduces the braking capacity and damages the rubber items in the brake assembly.

CHANGING THE FORK OIL

INSP
ADJ



7. After removing most of the oil, pump up and down with the fork to get any remaining oil out.

8. Inspect:
 - The O ring (plug)Damages → Replace

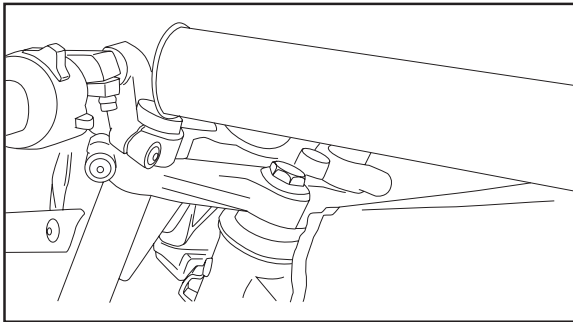

9. Fill up with:
 - Fork oil



Oil capacity of the front fork (each arm):
235 cm³
Recommended oil:
10W fork oil or equivalent

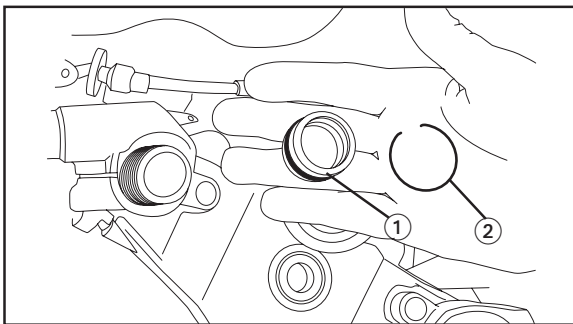

10. After filling this, pump the fork up and down slowly, to distribute the oil.

11. Install:
 - The plug ①
 - The circlip ②

⚠ WARNING

Always use a new circlip

12. Tighten:
 - The clamp screw (upper and lower steering shank)



Clamp screw (upper steering shank):
2.2 kg • m

INSPECTING THE TYRES

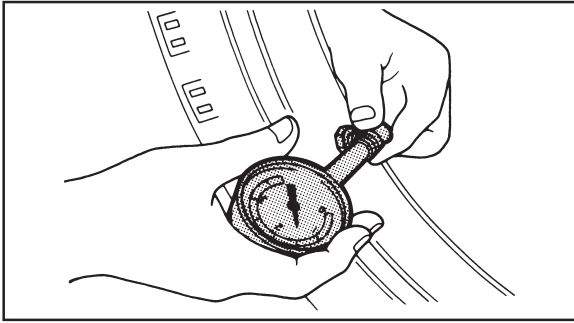

INSPECTING THE TIRE

- Measure:
 - The air pressure
 Out of specification → Adjust

Basic weight: With oil and fuel tank full	124.2 kg.	
Maximum load*	195 kg.	
Cold tyre pressure Up to 90 kg. (198 lb) load	Front (1.8kg/cm ²)	Rear (2.0kg/cm ²)
From 90 kg (198 lb) up to maximum load*	(1.9kg/cm ²)	(2.3kg/cm ²)

* The load is the total weight of the equipment, driver, passenger and accessories

⚠ WARNING

The tire pressure must be checked and adjusted when the tire is at ambient temperature. This must be adjusted depending on the total weight of the equipment, driver and accessories (fairing, cases, etc. if these have been approved for this model) as well as on the speed of the vehicle.

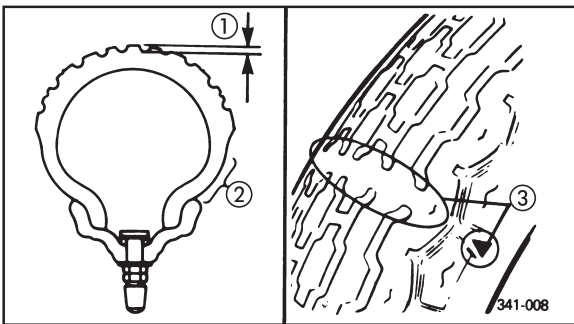

- Inspect:
 - The surfaces of the tires
 Wear/damage → replace

**Minimum depth of the tire tread pattern:
(front and rear)
1.6 mm (0.06 inch)**

- (1) Depth of the tread
- (2) Lateral
- (3) Wear indicator

⚠ WARNING

It is dangerous to drive the motorcycle with excessively worn tyres. When bands start to be seen in the tread of a tire change this immediately



INSPECTING WHEELS

1. Inspect:
 - The wheels
Damage / deformations → Replace

NOTE: _____

After changing the tire or the wheel always balance the wheel.

⚠ WARNING _____

Do not attempt to repair a defective wheel.

INSPECTING CABLES

1. Inspect:
 - The throttle cable
 - The tachometer cable
 - The clutch cable
 - The speedometer cableCheck any damage in the cable sheaths.

Corrosion / Damage → Replace

Obstruction → Change the route

Lack of smoothness → Lubricate



LUBRICATION

Lubrication of cables

Lubricating steps:

- Keep the cable in vertical position
- Apply lubricant to the upper end of the cable
- Keep this in a vertical position until the oil comes out of the other end
- Leave any excess oil to drain off and then reinstall the cable.



Engine oil:
SAE 10W30 of SE type

Lubrication of levers and pedals

Lubricate the rotating parts of each lever and pedal.



Engine oil:
SE type SAE 10W30

Lubrication of the side stand

Lubricate the rotating parts.



Engine oil:
SE type SAE 10W30

Lubricating the swingarm

Lubricate the rotating points of the swingarm



Grease
Light with lithium soap base



ELECTRICAL SYSTEM

INSPECTING THE BATTERY

1. Remove:
 - The seat

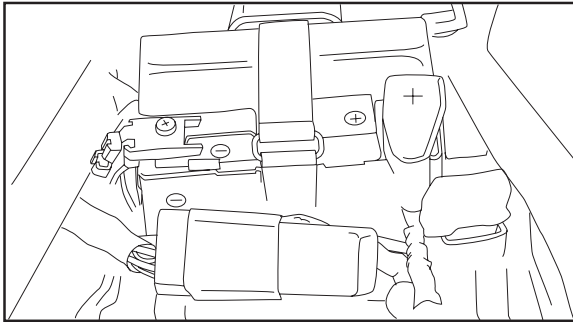

2. Inspect:
 - The battery terminals

Dirty terminals → Clean with a metal brush

Bad connection → Correct

NOTE: _____

After cleaning the terminals, apply grease lightly

Change the battery in the following case:

- When the voltage does not reach the value specified, even after many hours charging.

 **M/F battery charger:**
90890-03150

CAUTION _____

This battery is the M/F no maintenance type. Never take the cover off. After sealing when inserting the electrolyte, this should never be opened again.

**⚠ WARNING**

The electrolyte in the battery is dangerous: it contains sulphuric acid and is consequently poisonous and very caustic.

Always observe the following preventive measures:

- Avoid any physical contact with the electrolyte as it may cause serious burns or permanent eye injuries:
- Use protective goggles when you handle batteries or work close to these.

Antidote (external):

- SKIN - Wash with water
- EYES - Wash off with water for 15 minutes and immediately consult the doctor.

Antidote (INTERNAL):

- Drink large amounts of water or milk, followed by milk of magnesia, beaten egg or vegetable oil.
- Immediately see a doctor.

Batteries ALSO generate explosive hydrogen gas, for which reason the preventive measures must always be taken:

- Charge batteries in a well-ventilated area.
- Keep batteries away from fire, sparks or flames (for example, welding equipment, lighted cigarettes, etc.)
- DO NOT SMOKE while batteries are being charged or handled.

KEEP BATTERIES AND ELECTROLYTE OUT OF CHILDREN'S REACH

INSPECTING THE FUSES

INSP
ADJ

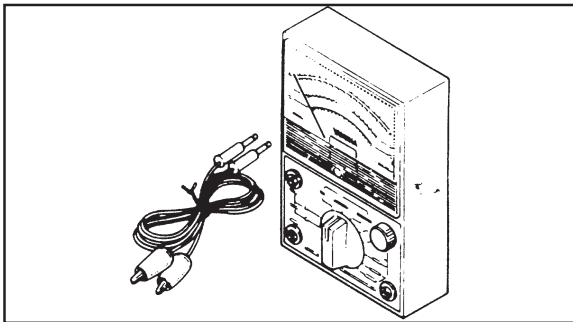
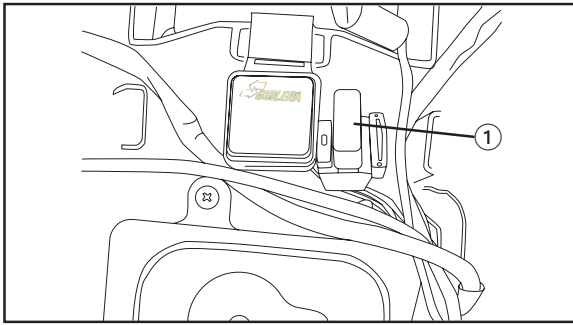

INSPECTING THE FUSES

1. Remove:
 - The seat
2. Remove:
 - The fuse ①
3. Inspect:
 - The fuse

Stages in inspection

- Connect the pocket tester to the fuse and check if the continuity is correct.

NOTE:

Place the tester selector in position “ Ω X 1”



Pocket tester:
90890 - 03112

- If the tester indicates ∞ the fuse will have blown - change this.

4. Replace:
 - The blown fuse

⚠ WARNING

Do not use fuses with a higher amperage than the value specified.

Installing a fuse with the wrong amperage could cause damage to the electrical system and even fires.

ADJUSTING THE HEADLIGHT BEAM / CHANGING A HEADLIGHT BULB

INSP
ADJ

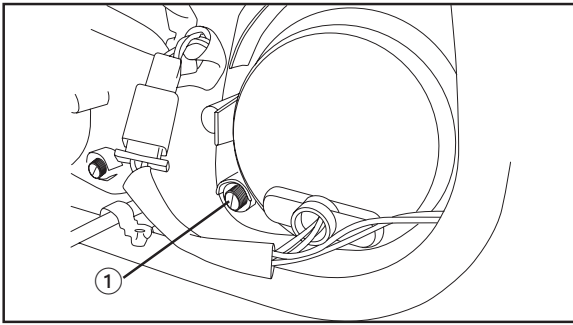

ADJUSTING THE RIGHT-HAND HEADLIGHT BEAM

1. Adjust :
 - The headlight beam (vertical)

To raise beam	Turn the adjustment screw ① clockwise
To lower the beam	Turn the adjustment screw ① anti-clockwise

ADJUSTING THE LEFT-HAND HEADLIGHT BEAM

1. Repeat the same operations as for the right-hand headlight

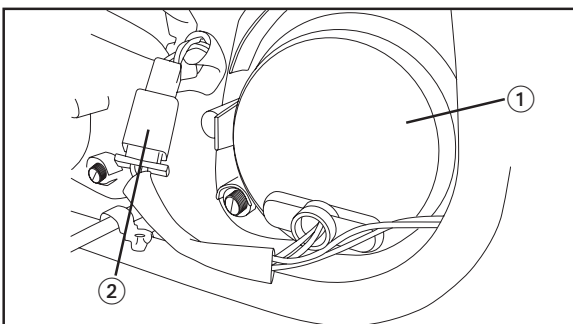

CHANGING A HEADLIGHT BULB

1. Remove:
 - The dust cover ① and the connection ②.
2. Take out:
 - The bulb

⚠ WARNING

Keep the bulb away from inflammable products and the hands while this is on, since it will be hot. Do not touch the bulb until it has gone cold.

3. Install:
 - The bulb (a new one)
Install the bulb in the bulb socket
4. Connect:
 - Connection of the headlight cables
5. Install:
 - Dust cover

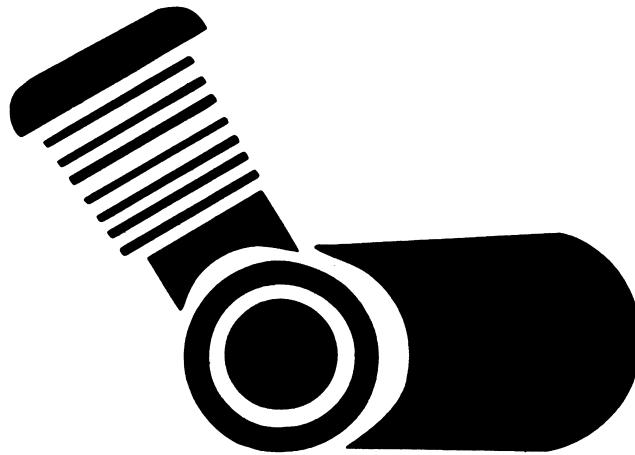

ENG

4



CHAPTER 4 ENGINE

REMOVING THE ENGINE	4-1
PREPARING FOR REMOVAL	4-1
PETROL TANK	4-2
AIR FILTER	4-3
EXHAUST PIPE	4-4
COOLANT PIPES	4-4
SPARK PLUG AND THERMOCONTACT CABLE	4-5
NEUTRAL SWITCH CABLE	4-5
OIL PUMP	4-5
CARBURETTOR	4-6
SHIFT LEVER, DRIVE CHAIN AND CLUTCH CABLE	4-6
ENGINE REMOVAL	4-7
DISMANTLING THE ENGINE	4-7
OIL PUMP	4-7
WATER PUMP COVER	4-7
RIGHT CRANKCASE COVER, OIL PUMP SHAFT AND WATER PUMP SHAFT	4-7
PRIMARY TRACTION GEARING AND CLUTCH	4-8
CDI MAGNETO	4-10
STARTER MOTOR	4-10
CYLINDER HEAD AND CYLINDER	4-11
PISTON PIN AND PISTON	4-12
CRANKCASE	4-12
SELECTOR AND SHIFT	4-13
CRANKSHAFT	4-13
BEARINGS AND OIL SEALS	4-14
INSPECTION AND REPAIR	4-14
CYLINDER HEAD	4-14
PISTON	4-15
CYLINDER	4-16
PISTON RINGS	4-17
PISTON PIN AND BEARING	4-17
AUTOLUBE PUMP	4-18
CLUTCH	4-18
SELECTOR	4-20
SHIFT	4-20
CRANKSHAFT	4-21
REVOLUTION COUNTER SENDER	4-21
BEARINGS AND OIL SEALS	4-22
CRANKCASE	4-22
ASSEMBLING AND ADJUSTING THE ENGINE	4-23
CRANKSHAFT	4-23
SHIFT AND SELECTOR	4-25
CRANKCASE	4-27
STARTER MOTOR	4-29
CDI MAGNETO	4-30
CLUTCH AND PRIMARY TRACTION GEARING	4-31
WATER PUMP SHAFT, OIL PUMP SHAFT AND RIGHT-HAND CRANKCASE COVER	4-35
WATER PUMP COVER	4-36
OIL PUMP	4-36
PISTON PIN AND PISTON	4-37
CYLINDER HEAD AND CYLINDER	4-38
INSTALLING THE ENGINE	4-40



ENGINE

REMOVING THE ENGINE

NOTE:

It is not necessary to remove the engine to take out the following components:

- Cylinder head
- Cylinder
- Piston

PREPARATION FOR REMOVAL

1. Remove all the dirt, mud, dust and foreign bodies before removing and dismantling the engine.
2. Use the proper tools and cleaning materials. See "CHAPTER 1. GENERAL INFORMATION - SPECIAL TOOLS".

NOTE:

When the engine is dismantled keep associated parts together. This includes gears, cylinder, piston and other items that have been coupled due to common wear. These items must be installed as an assembly or should be replaced by new ones.

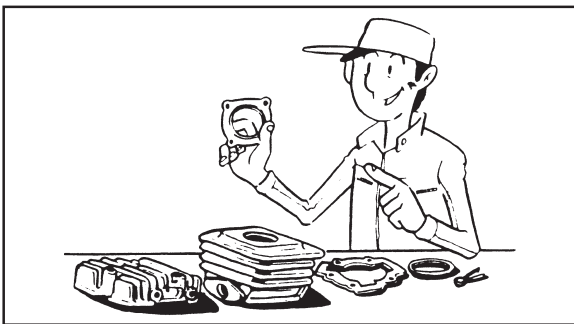

3. When dismantling the engine, clean all the parts and place these in trays in the dismantling order. This will reduce the assembly time and ensure that all the parts removed are properly fitted in the engine again.
4. Remove the lower fairing. Place the engine on a suitable support.
5. Start the engine and let it warm up.
6. Completely drain the transmission oil. See the section on "CHANGING THE TRANSMISSION OIL in CHAPTER 3, REGULAR INSPECTIONS AND ADJUSTMENTS".
7. Completely drain the coolant. See the section on "CHANGING THE COOLANT in CHAPTER 3. COOLING SYSTEM".

REMOVING THE ENGINE

ENG

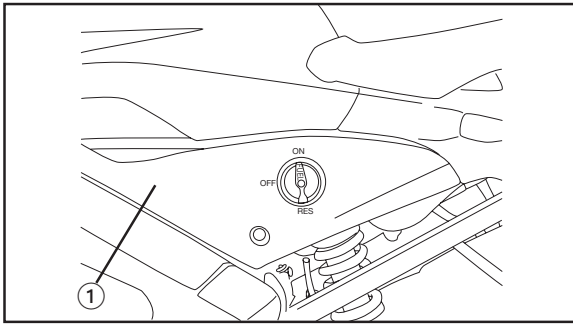

PETROL TANK

1. Remove:
 - Seat
 - Grip strap
 - Side covers (left ① / right)

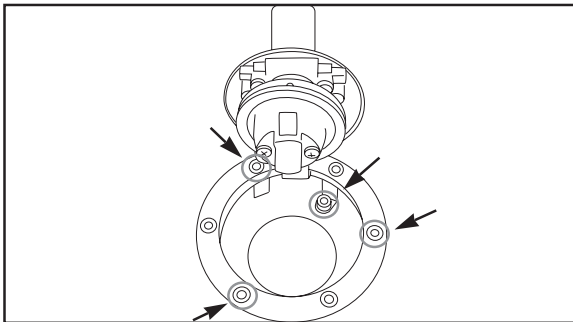

2. Remove the fuel tank cap

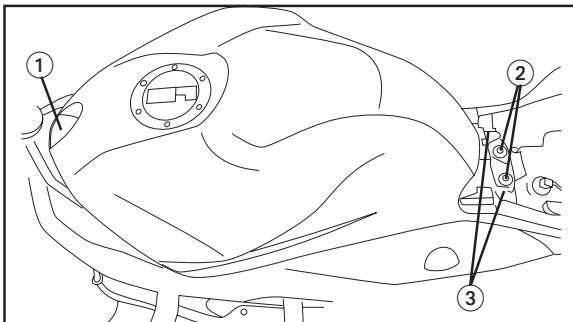

3. Remove the bolts of the fuel tank ① and ② and of its cover ③.

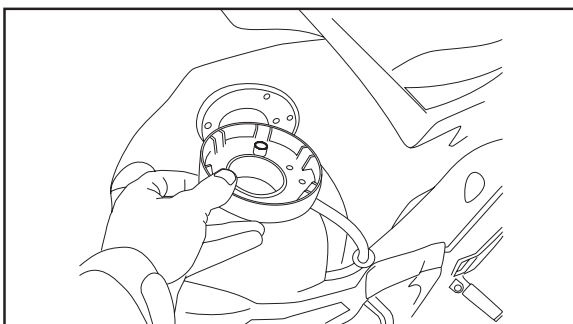

4. Lift up the cover of the fuel tank as shown in the drawing and remove the tray and the fuel overflow pipe from its original position.

NOTE:

Do not remove the lower part of the overflow pipe from its original position

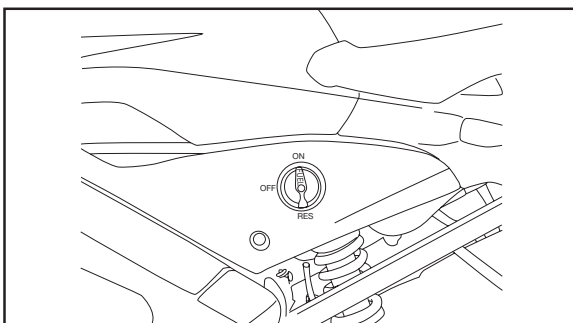

5. Locate the fuel tap in the closed position (OFF) and take the lever out of this.
6. Provisionally lift up the fuel tank and its cover, disconnect the fuel pipe and remove the tank and the cover.

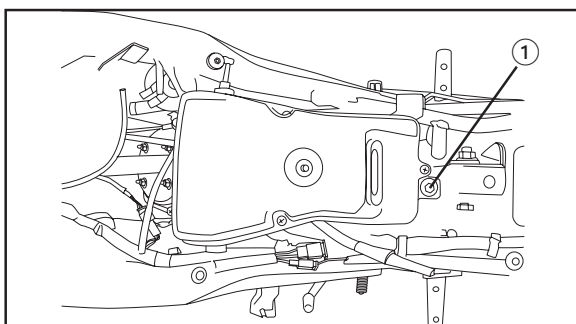

AIR FILTER

1. Remove:
 - Securing screw ①

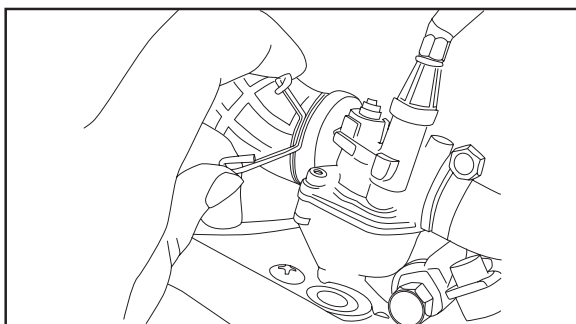

2. Take out:
 - Clip

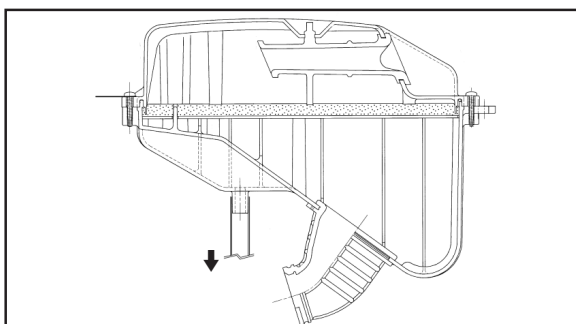

3. Disconnect:
 - Rubber pipe

4. Remove
 - Filter casing

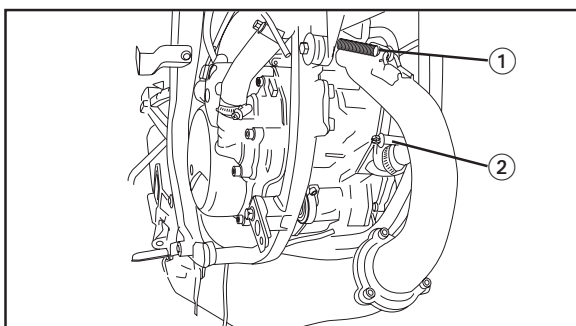

EXHAUST PIPE

1. Remove:
 - Springs ①
 - Clamp of the AIS system ②

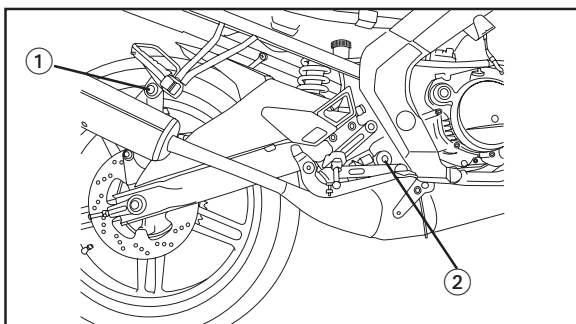

2. Remove:
 - Exhaust pipe screws ① and ②
 - Exhaust pipe

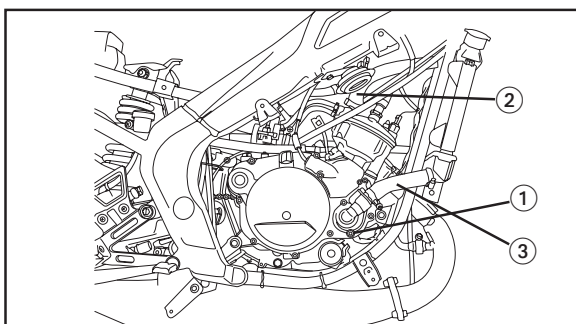

COOLANT PIPES

1. Remove:
 - Fairing
 - Drainage screw ①
2. Drain:
 - Coolant liquid
3. Disconnect:
 - Coolant pipe (inlet) ②
 - Coolant pipe (outlet) ③

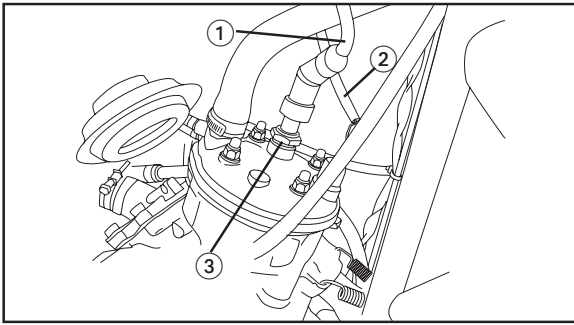

SPARK PLUG AND THERMOCONTACT CABLE

1. Disconnect
 - Spark plug cable ①
 - Thermocontact cable ②
2. Loosen:
 - Spark plug ③

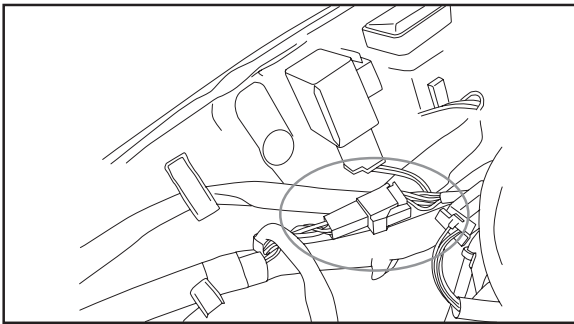

CDI CABLE

1. Disconnect:
 - CDI cable

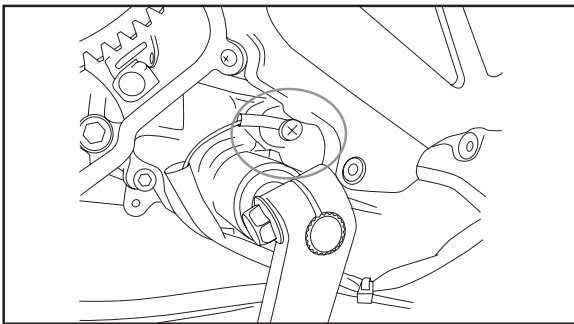

NEUTRAL SWITCH CABLE

1. Disconnect:
 - Neutral switch cable

OIL PUMP

1. Remove:
 - Cover of the oil pump

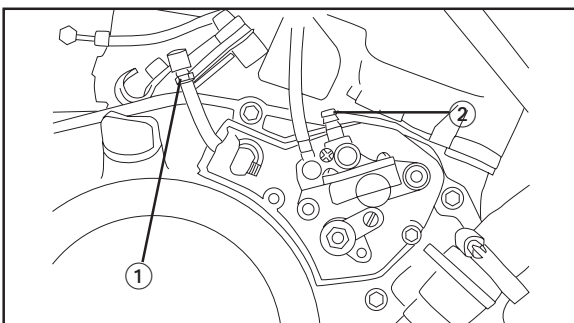

2. Remove:
 - Cable of the oil pump ①
3. Disconnect:
 - Oil inlet tube to the pump ②

NOTE:

Plug the oil inlet pipe to the pump so the oil from the tank does not get out.

REMOVING THE ENGINE

ENG

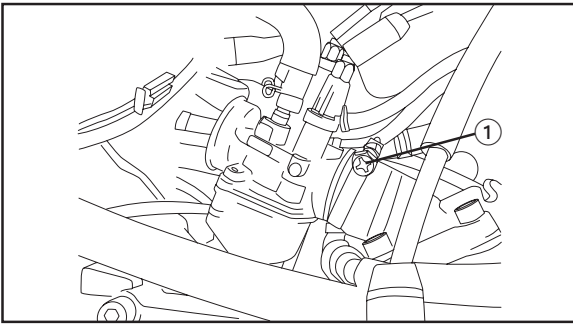

CARBURETTOR

1. Loosen:
 - Carburettor securing screw ①
2. Remove:
 - Upper carburettor cover ①
 - Throttle cable ②
 - Tube for supplying the oil pump ③
 - Coolant pipes ④
 - Starter cover ⑤
 - Starter cable ⑥
3. Remove:
 - Carburetor
 - Carburetor joint
 - Plate casing

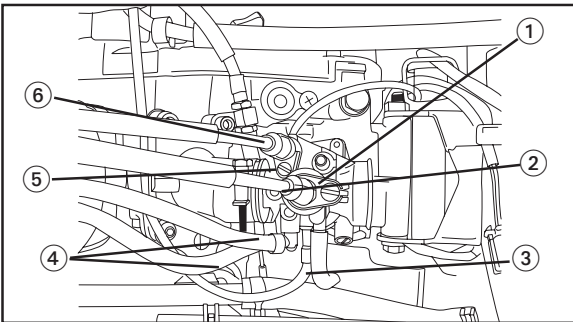

NOTE:

Cover the carburetor with a clean cloth to prevent dirt from getting into this.

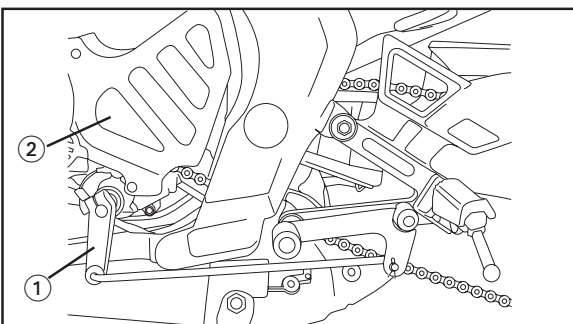

SHIFT CAM, DRIVE CHAIN AND CLUTCH CABLE

1. Remove:
 - Shift cam ①
 - Pinion cover ②
2. Loosen:
 - Rear axle nut
 - Chain tensor
 - Drive chain
3. Remove:
 - Drive chain ①

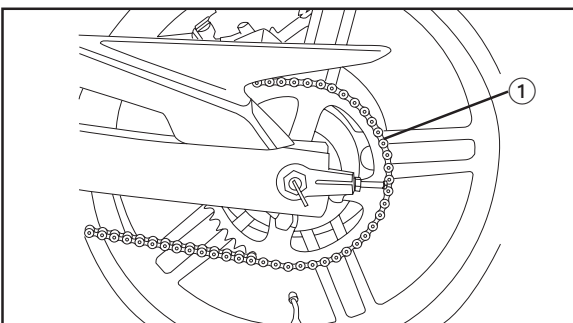

REMOVING THE ENGINE / DISMANTLING THE ENGINE

ENG

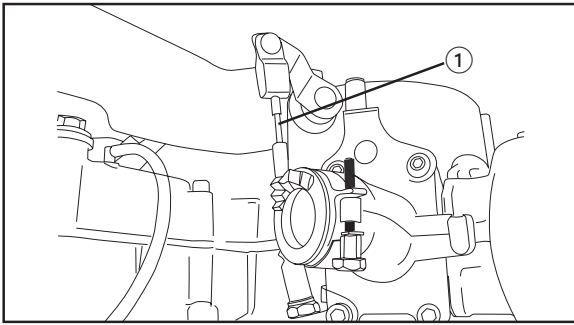

4. Disconnect:
 - Clutch cable ①First disconnect the cable of the crankcase side and then the end at the handlebar lever

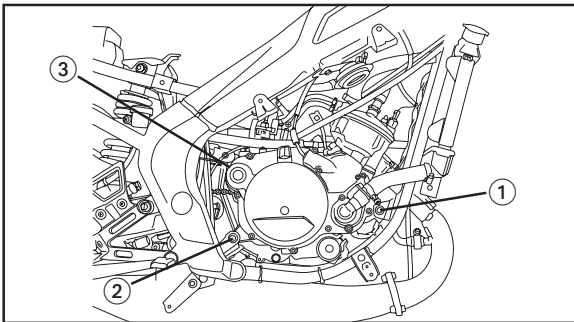

REMOVING THE ENGINE

1. Remove:
 - Front engine mounting screw ①
 - Rear lower engine mounting screw ②
 - Rear upper engine mounting screw ③
 - Engine assembly

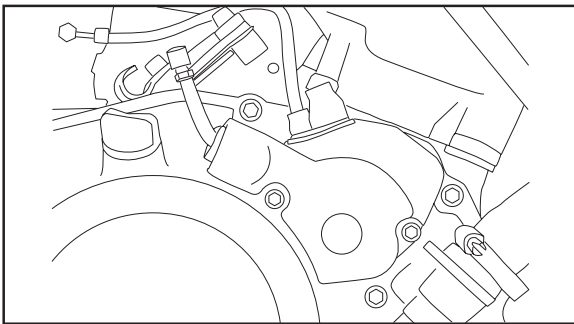

OIL PUMP

1. Remove:
 - Oil pump cover
 - Oil pump assembly

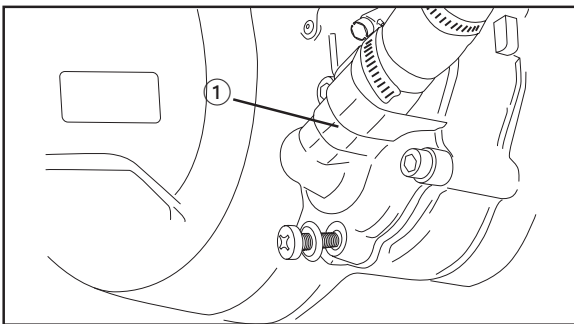

WATER PUMP COVER

1. Remove:
 - Water pump cover ①
 - Water pump cover gasket

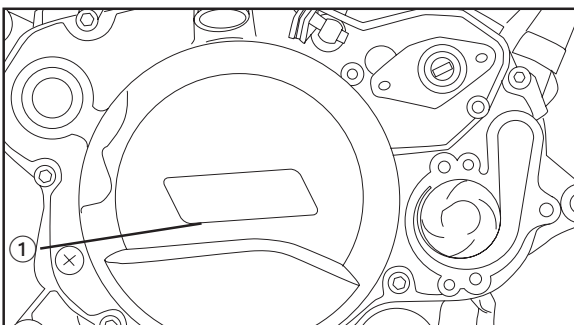

RIGHT CRANKCASE COVER, OIL PUMP SHAFT AND WATER PUMP SHAFT

1. Remove:
 - Right-hand oil pump cover ①

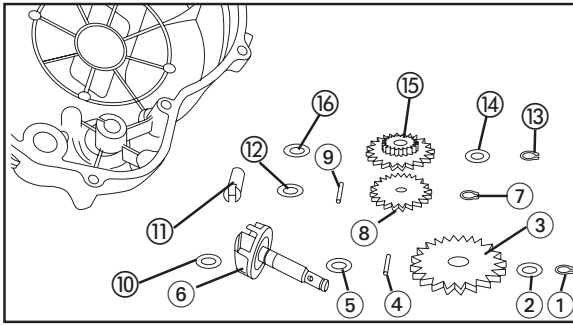

2. Remove
 - Clip ①
 - Washer ②
 - Water pump driven gear ③
 - Pin ④
 - Washer ⑤
 - Water pump shaft ⑥
 - Clip ⑦
 - Oil pump driven gear ⑧
 - Pin ⑨
 - Washer ⑩
 - Oil pump shaft ⑪
 - Washer ⑫
 - Clip ⑬
 - Washer ⑭
 - Intermediate gear ⑮
 - Washer ⑯

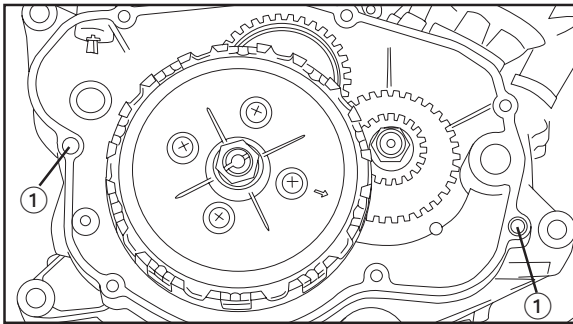

3. Remove:
 - Locators ①
 - Gasket

CLUTCH AND PRIMARY TRACTION GEARING

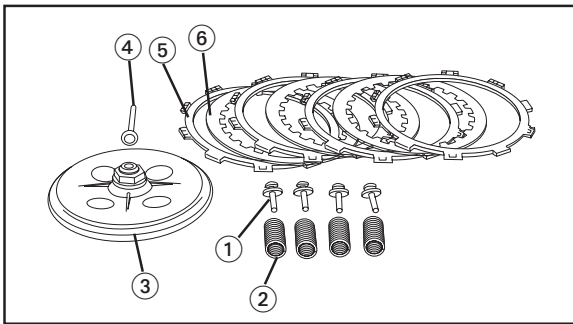

1. Remove:
 - Securing screws for the clutch springs ①
 - Clutch springs ②
 - Pressure plate ③
 - Push rod n° 1 ④
 - Friction discs ⑤
 - Clutch discs ⑥

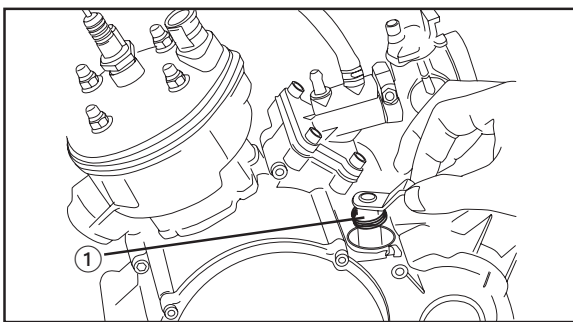

2. Remove:
 - Push rod ball
 - Push rod N° 2
 - Shaft set of the clutch push lever ①

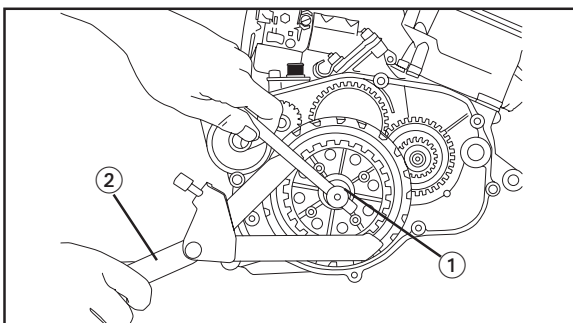

3. Loosen:
 - Safety nut of the clutch casing ①
 Use the universal clutch holder ② (90890-04086) to hold the clutch cone

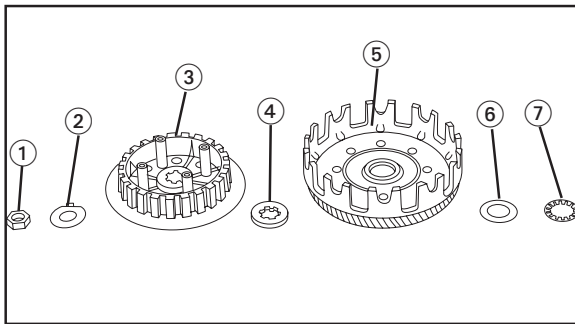

4. Remove:
 - Clutch boss safety nut ①
 - Washer ②
 - Clutch boss ③
 - Washer ④
 - Clutch housing ⑤
 - Washer ⑥
 - Conical spring washer ⑦

⚠ WARNING

Pay attention to the position of the conical spring washer. Install as shown in the figure.

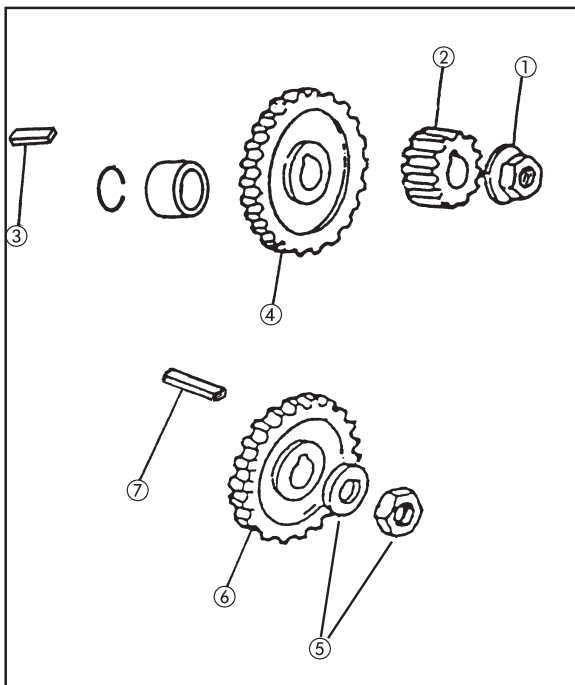
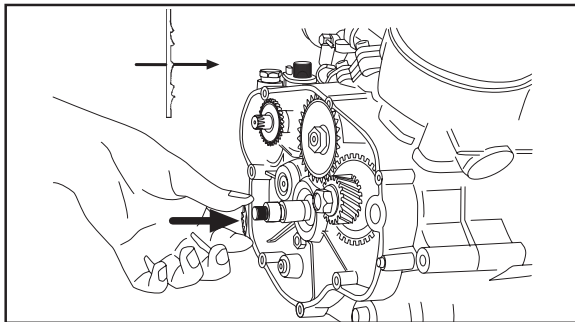

5. Loosen:
 - Balancer shaft nut
6. Remove:
 - Primary traction gear nut ①
 - Primary traction gear ②
 - Key ③
 - Balancer shaft drive gear ④
 - Balancer shaft washer and nut ⑤
 - Balancer shaft driven gear ⑥
 - Key ⑦

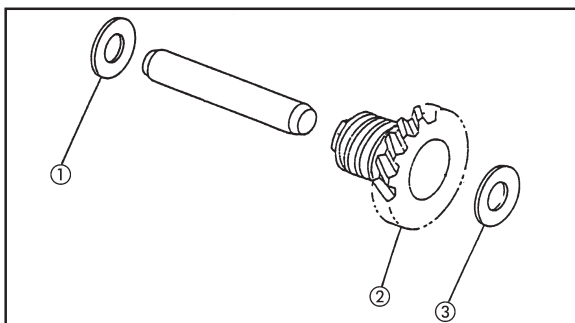

7. Remove:
 - Washer ①
 - Tachometer worm gear ②
 - Washer ③

8. Remove:
 - Magnetic flywheel cover
 - Neutral switch

REMOVING THE ENGINE

ENG

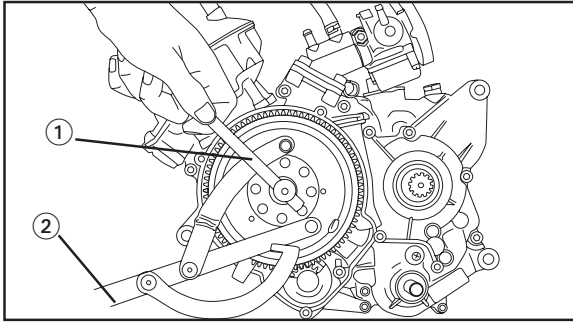

CDI MAGNETO

1. Remove:
 - Left-hand crankcase cover and gasket
 - Flywheel securing nut.



Use the flywheel-holding tool
90890-01235 ①

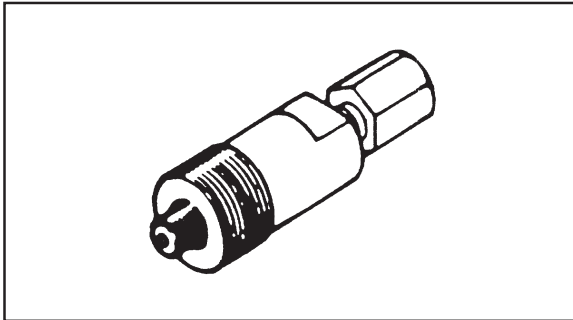

2. Remove:
 - CDI flywheel



Use the flywheel extractor tool
90890 - 01189 ②
and the flywheel fixer
90890-01235 ①

- Crankshaft key
- Stator coils
- Coil holder plate

NOTE:

Mark the coil holder plate and the crankcase with a pointed instrument

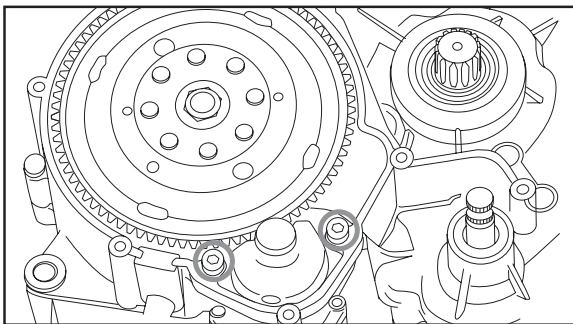

STARTER MOTOR

1. Remove:
 - Securing screws

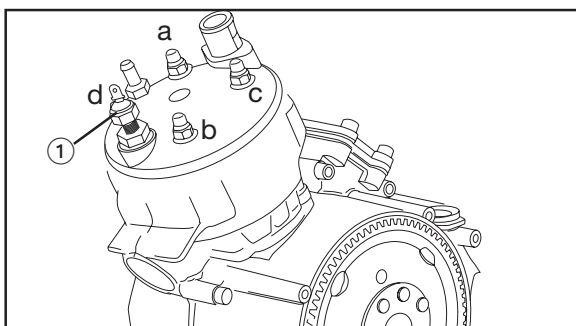
**CYLINDER HEAD AND CYLINDER**

1. Remove:
 - Spark plug
 - Nuts and washers
 - Thermocontact ①

NOTE: _____

Following the order stated in the drawing (a, b, c,d), loosen each screw " of a turn and then fully unscrew them.

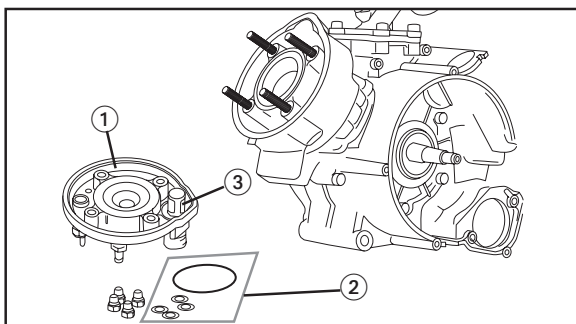

2. Remove:
 - Cylinder head ①
 - O rings ②
 - Thermostat ③

⚠ WARNING _____

Handle the thermocontact with special care. Do not grip it too tightly or drop it. If it is dropped it must be replaced with a new one.

3. Remove:
 - Cylinder

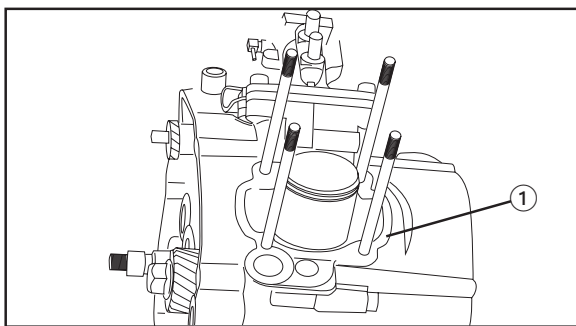

4. Remove:
 - Cylinder gasket ①
5. Remove:
 - Reed valve assembly

DISMANTLING THE ENGINE

ENG

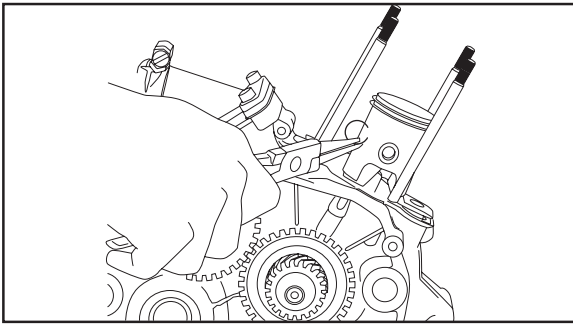

PISTON PIN AND PISTON

1. Take out:
 - Piston pin clip ①

NOTE:

Before removing the pin clip from the piston, cover the crankcase with a clean cloth to prevent the clip from falling into the crankcase.

2. Take out:
 - The piston pin
 - Piston
 - Bearing

NOTE:

Before taking out the pin, remove any burrs from the slot of the clip and the pin hole. If it were still difficult to take out the pin after removing any burrs, use the piston pin extractor (90980 - 01304)

CAUTION

Do not use a hammer to take out the piston pin

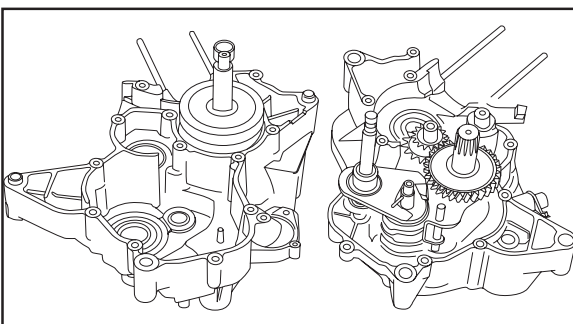
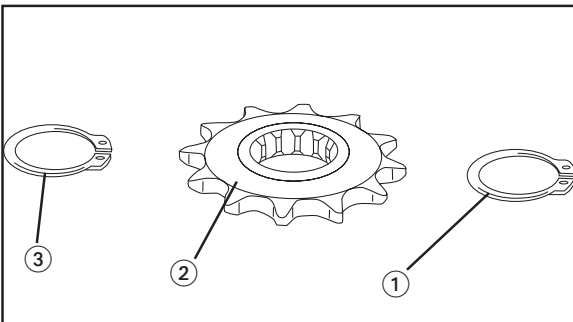

CRANKCASE

1. Take out:
 - Circlip ①
 - The output gear ②
 - Circlip ③
2. Take out:
 - The crankcase securing screws

NOTE:

Loosen each of the screws a quarter of a turn. Then unscrew them completely and take them out.

3. Separate
 - Crankcase

NOTE:

Tap these gently and alternately

**CAUTION**

Use a soft hammer to hit the crankcase lightly. Only tap the reinforced parts. Do not tap the closing surface. Work slowly and carefully. Make sure that the crankcase comes apart gently. If the crankcase does not come apart, make sure that no screws or locator have been left in. Do not force this.

4. Take out:
 - Locators
5. Take out:
 - Balancing shaft

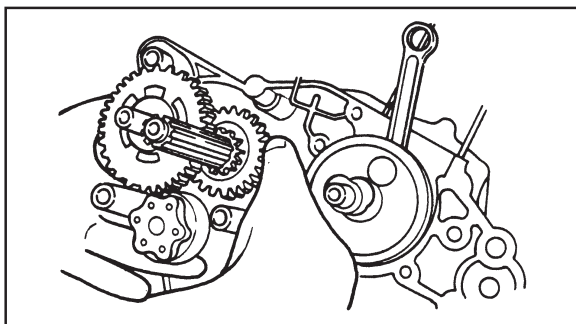
**SELECTOR AND SHIFT**

1. Take out:
 - Guide bars
 - Secondary shaft, primary shaft, selector cam and set of selector forks.
 - Shift selector

NOTE:

Take note of the position of each part. Pay special attention to the location and direction of the selector forks.

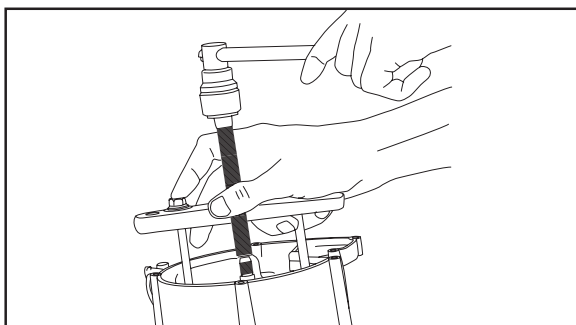
**CRANKSHAFT**

1. Take out:
 - Crankshaft
 - Crankshaft extractor 1 (90890-11030)



BEARINGS AND OIL SEALS

NOTE: _____

- It is not necessary to take out the bearings and oil seals unless these are damaged. See the section on “BEARINGS AND OIL SEALS” in CHAPTER 1.

1. Take out:
 - The oil rings

CAUTION _____

- Use a screwdriver to take out the seal.
- Place a piece of wood under the screwdriver so as not to damage the crankcase

2. Take out:
 - The bearings

NOTE: _____

- To facilitate removal and installing first heat up the crankcase to roughly 95 ~125°C. Heat it up slowly to this temperature.

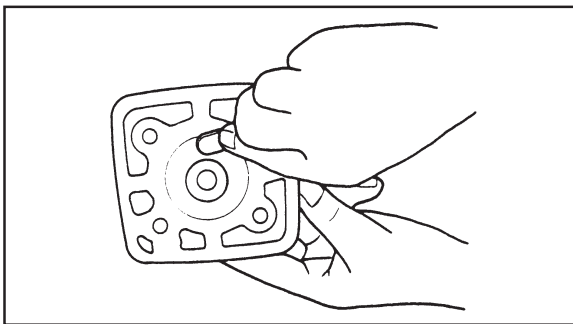

INSPECTION AND REPAIR

CYLINDER HEAD

1. Eliminate:
 - Any carbon deposited.
Use a rounded scrap

NOTE: _____

Do not use any sharp tool and avoid damaging or scratching the :

- Spark plug thread
- Cylinder head

2. Inspect
 - Cylinder head (inside)
Remains of any material deposited /rust
→ remove
 - Deformation of the cylinder head
Out of specification → Sand down

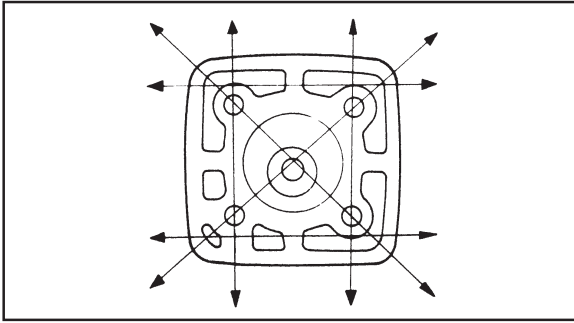

Measuring warping and steps for sanding the surface:

- Put a straightedge and a thickness gauge on the cylinder head
- Measure the warpage
Outside specifications → Sand / Replace



Maximum cylinder head warpage:
0.03 mm

- Place n° 400~600 wet sandpaper on the surface and sand this down in a figure eight shape.

NOTE

Turn the cylinder head round several times so as not to take too much material off only one side.

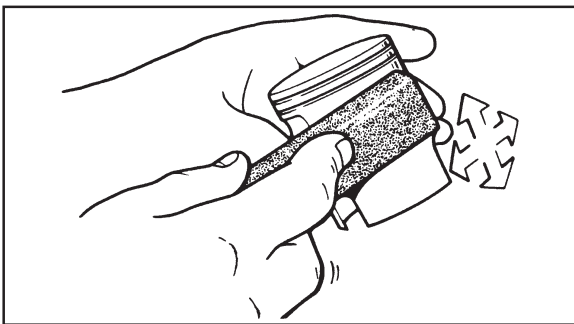
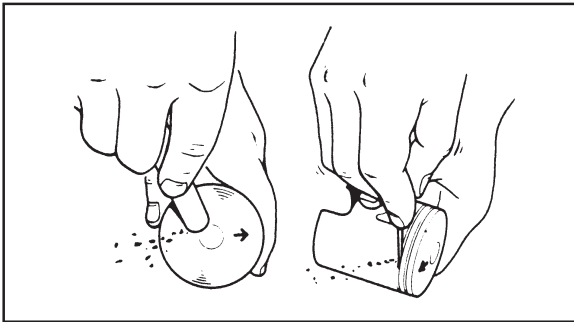

PISTON

1. Eliminate:
 - Any carbon deposited (on the piston and the ring slots)
2. Eliminate:
 - Scratches and deposits found (on the wall of the piston)
 - Use n° 600~800 water sandpaper

NOTE:

Sand this in a cross shape and do not sand excessively.

3. Inspect:
 - The piston wall
 - Wear / Scratching / damaged → Replace

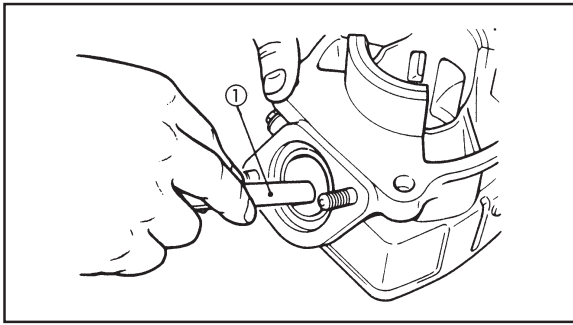

CYLINDER

1. Eliminate:
 - Any carbon deposits
Use a rounded scrap ①
2. Inspect:
 - The cylinder
Mineral deposited / rust → Remove
 - Wall of the cylinder
Wear / scratches → grind or replace
3. Measure:
 - Diameter of the cylinder "C"
Outside specifications → Grind
Use internal gauge ①

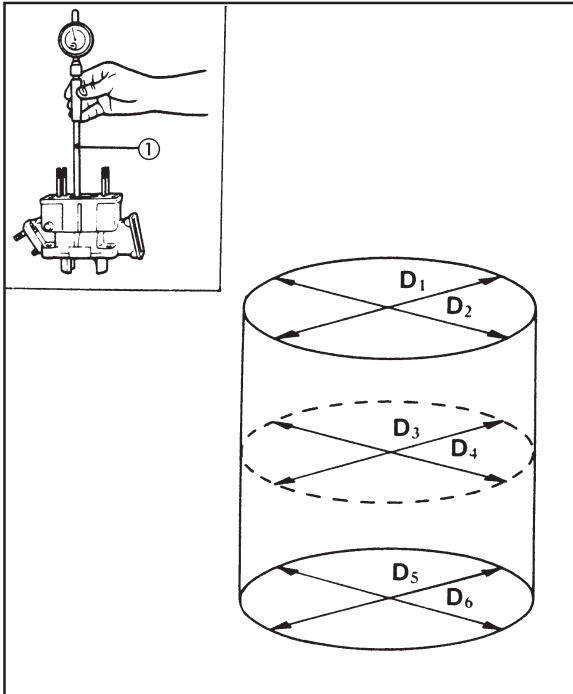

Standard	Standard	Wear limit
Diameter of cylinder "C"	40.293 ~ 40.312	40.4 mm
Diameter of cylinder "T"	—	0.05 mm
Ovalling "R"	—	0.01 mm

C = D maximum

T = (D₁ or D₂ maximum) - (D₅ or D₆ minimum)

R = (D₁ D₃ or D₅ maxim) - (D₂ D₄ or D₆ minimum)

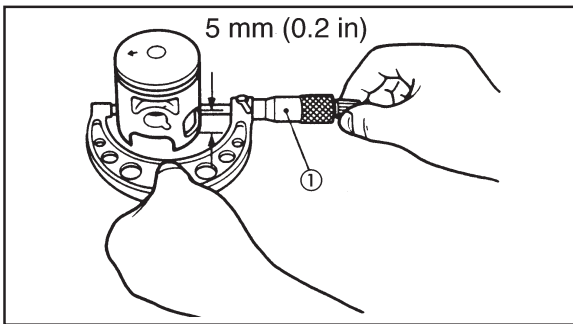

4. Measure:
 - Outside piston diameter "P"
 - Outside specifications → Replace
Use the micrometer ①

	Micrometer: 90896 - 03008
--	-------------------------------------

NOTE: _____

The measurement should be taken 5 mm from the lower edge of the piston

	Size
Standard	40.25 mm
Oversize 1	40.6 mm
Oversize 2	40.8 mm



5. Measure
 - Piston free play:
Outside specifications → Grind the cylinder or replace the piston



Piston clearance = C- P:
0.049 ~ 0.062 mm

C: Internal cylinder diameter
P: External piston diameter

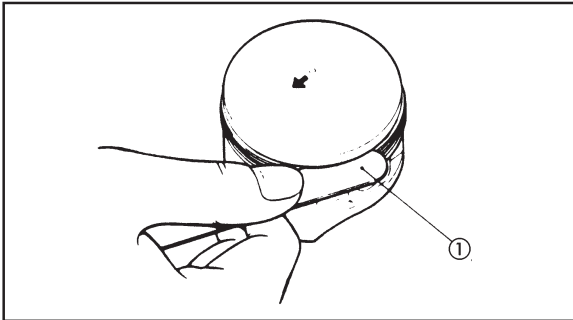

PISTON RINGS

1. Measure:
 - Lateral clearance
Out of specifications → Replace the piston and/or rings
Use the thickness gauge ①



Feeler gauge:
90890 - 03079



Lateral clearance:
Upper ring / 2nd ring
0.03 ~ 0.06 mm

2. Install:
 - The piston ring (in the slot for the ring)
 - Push the ring with the piston crown.
3. Measure:
 - Clearance between ends
Out of specifications → Change set of rings.
Use the feeler gauge ①

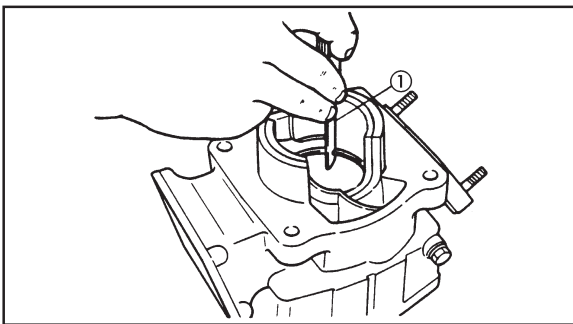

Clearance between ends:
Upper ring / 2nd ring
0.15 ~ 0.30 mm

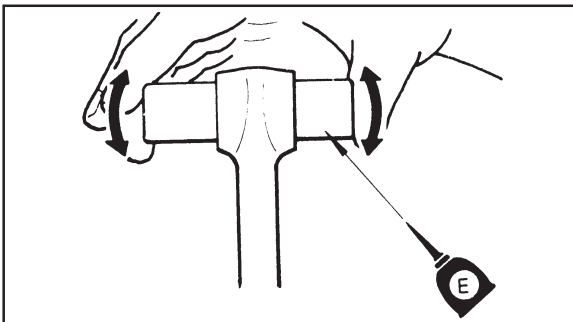

PISTON PIN AND BEARING

1. Lubricate:
 - The piston pin
 - The bearing
2. Install:
 - The piston pin
 - Bearing (on the little end)

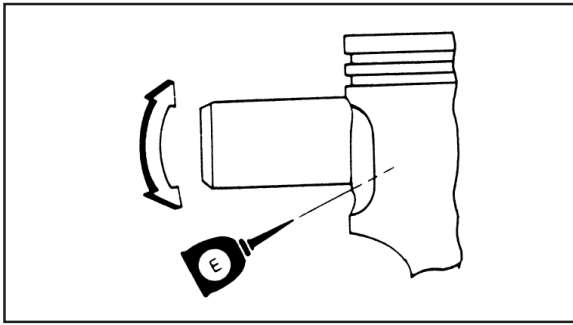

3. Check:
 - Free play
There should not be any considerable play
Free play exists → check to see if the con rod is worn / change the pin, bearing and/or con rod, if necessary.
4. Install:
 - Piston pin (on the piston)
5. Check:
 - Free play (after the pin has been fitted on the piston)
There should not be any considerable free play
There is free play → change the pin, and/or piston.
6. Inspect:
 - Piston pin and bearing
Blued by heat → Replace

AUTOLUBE PUMP

Wear or an internal malfunction may alter the factory-set flow of the pump. However, this is not a very common situation.

If you suspect the flow is incorrect check the following items:

1. Check:
 - Feed pipe
Obstruction → Clear
 - Supply pipe
Obstruction → Unblock
 - Autolube pump
Damaged → Change
2. Inspect:
 - If there is air
There is air → Bleed
 - Flow:
 - Minimum outlet / 200 stroke 6 cc/h at 3000 rpm
 - Maximum outlet /200 stroke 28 cc/h at 3000 rpm

NOTE

The marks should coincide when the throttle is closed.

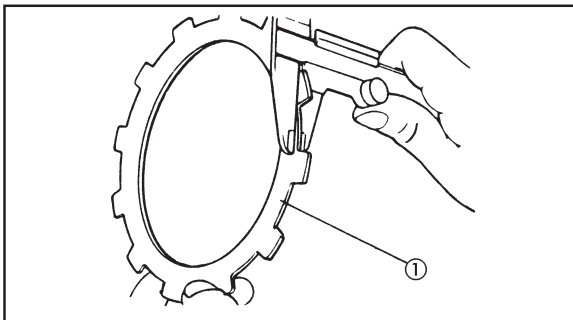

CLUTCH

1. Inspect
 - Friction disc ①
Damaged / Worn → Change the full set of friction discs



2. Measure:
- Thickness of the friction disc
Out of specifications → Change the full set of friction discs.
Measure at 4 points



Wear limit :
2.7 mm

3. Inspect:
- Clutch disc
Damaged → change the full set of clutch discs

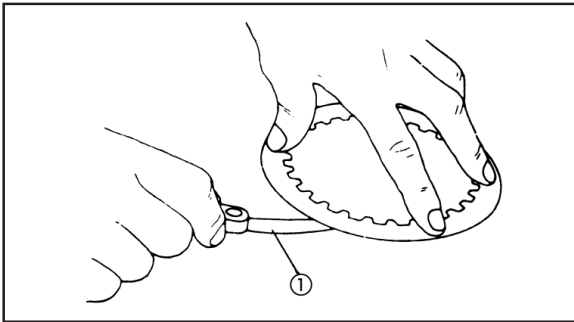

4. Measure:
- Warpage of the clutch disc
Out of specifications → Change the full set of clutch discs.
Use the surface and feeler gauge ①



Warpage limit:
0.05 mm (0.002 inches)

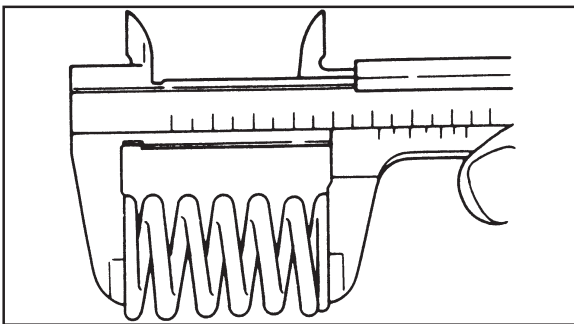

5. Measure:
- Free length of the clutch spring
Out of specifications → Change the full set of springs



Minimum length of clutch spring :
30.0 mm

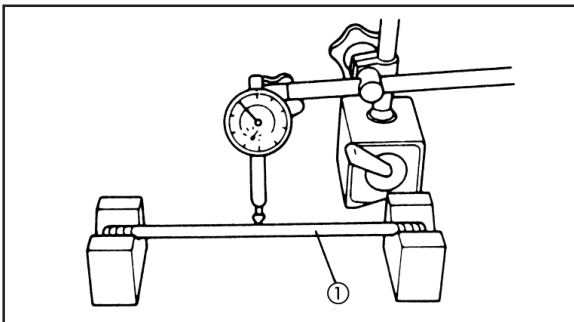

6. Measure:
- Run out (long rod) ①
Out of specifications → Replace
Use V blocks and a comparator (90890 - 03097)



Warpage to limit:
0.15 mm

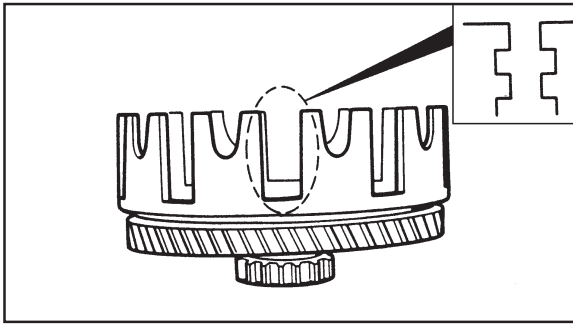

7. Inspect:
 - Slots in the clutch drum
Cracks / wear / damaged → remove
deburr or change
 - Bearing of the clutch drum
Scraping / Wear / Damaged → Replace

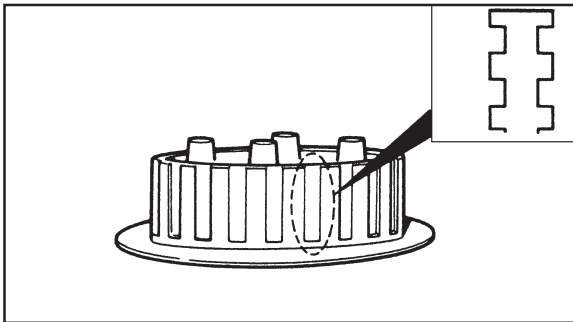

8. Inspect:
 - Splines in the clutch boss
Scratches/Wear/Damaged → Change
the clutch boss

NOTE: _____
 Scratching in the clutch boss splines will
 cause faulty operation

SELECTOR

1. Inspect:
 - Return spring of the selector
Damaged → Change
 - Shift shaft
Damaged / Curved / Worn → Change

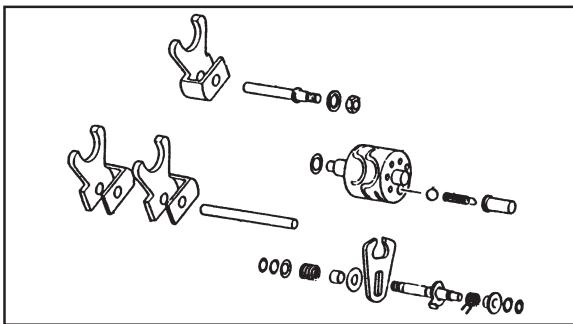

CHANGE

1. Inspect:
 - Forks of the selector (contact surface of
the gearing and the selector cam)
Wear / Scraping / Curved / Damaged →
Change
 - Guide bars
Curved / Worn → Change
2. Check:
 - Movement of the selector forks (in their
respective guide bar)
Operation not smooth → Change selec-
tor fork and/or bar guide.
3. Inspect
 - Slots in the selector cam
Wear / Damaged / Scratching →
Change
 - Ring of the selector cam
Damaged / Worn → Change

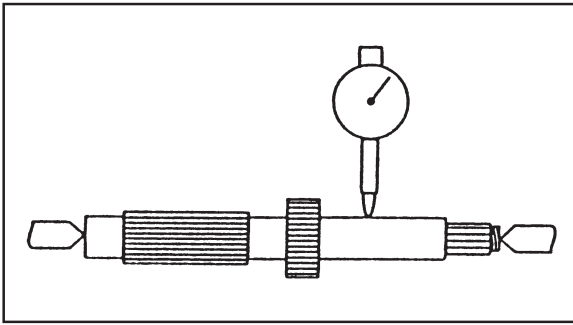

4. Measure:
 - Run out of the shaft
Outside specifications → Change
Use the centring tool and the comparator (90890 - 03097)



Eccentricity limit:
0.08 mm

5. Inspect:
 - Gearing
Damaged / Wear → Change
6. Check:
 - Operation of the gearing
Operation stiff → Change
7. Inspect:
 - Coupling lugs
Cracks / Wear / Damaged → Change

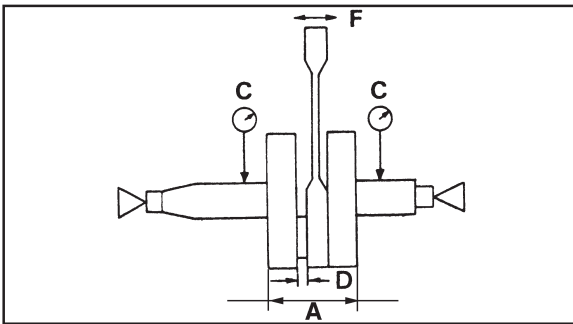

CRANKSHAFT

1. Measure:
 - Run out limit "C"
 - Clearance of the con rod big end "D"
 - Limit of play of the con rod little end "F"
Outside specifications → Change
Use V blocks, the Comparator (90890 - 03097) and a feeler gauge.



Width between blades "A":

41.90 ~ 42.00 mm

Eccentricity limit "C":

0.03 mm

Clearance of con rod big end "D":

0.015 ~ 0.026 mm

Free play of the con rod little end "F"

0.20 ~ 0.61 mm

TACHOMETER GEAR

1. Inspect:
 - Drive gear and driven gear
Damaged / worn → Change
2. Check:
 - Operation of the sender
Operation stiff → Change

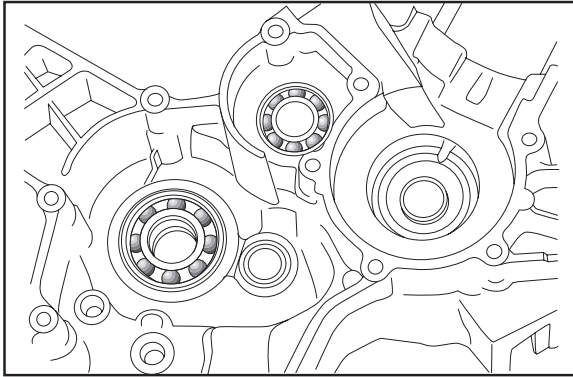

BEARINGS AND OIL SEALS

1. Inspect:
 - Bearing
Perforated / Damaged → Change
 - Oil seal lips
Damaged / Worn → Change

CRANKCASE

1. Thoroughly wash the halves of the crankcase with mild solvent.
2. Clean the whole surface of the joints and the crankcase.
3. Inspect:
 - Crankcase
Cracks / Damaged → Change
 - Oil supply conduits blocked → Unblock with compressed air



ASSEMBLING AND ADJUSTING THE ENGINE CRANKSHAFT

- | | | |
|--------------|--------------------|------------|
| ① Crankshaft | ⑧ Rings | ⑮ Balancer |
| ② Con rod | ⑨ Pin | ⑯ Bearing |
| ③ Bearing | ⑩ Circlip | ⑰ Bearing |
| ④ Bearing | ⑪ Bearing | ⑱ Gear |
| ⑤ Seal | ⑫ Key | ⑲ Key |
| ⑥ Seal | ⑬ Key | |
| ⑦ Piston | ⑭ Traction gearing | |

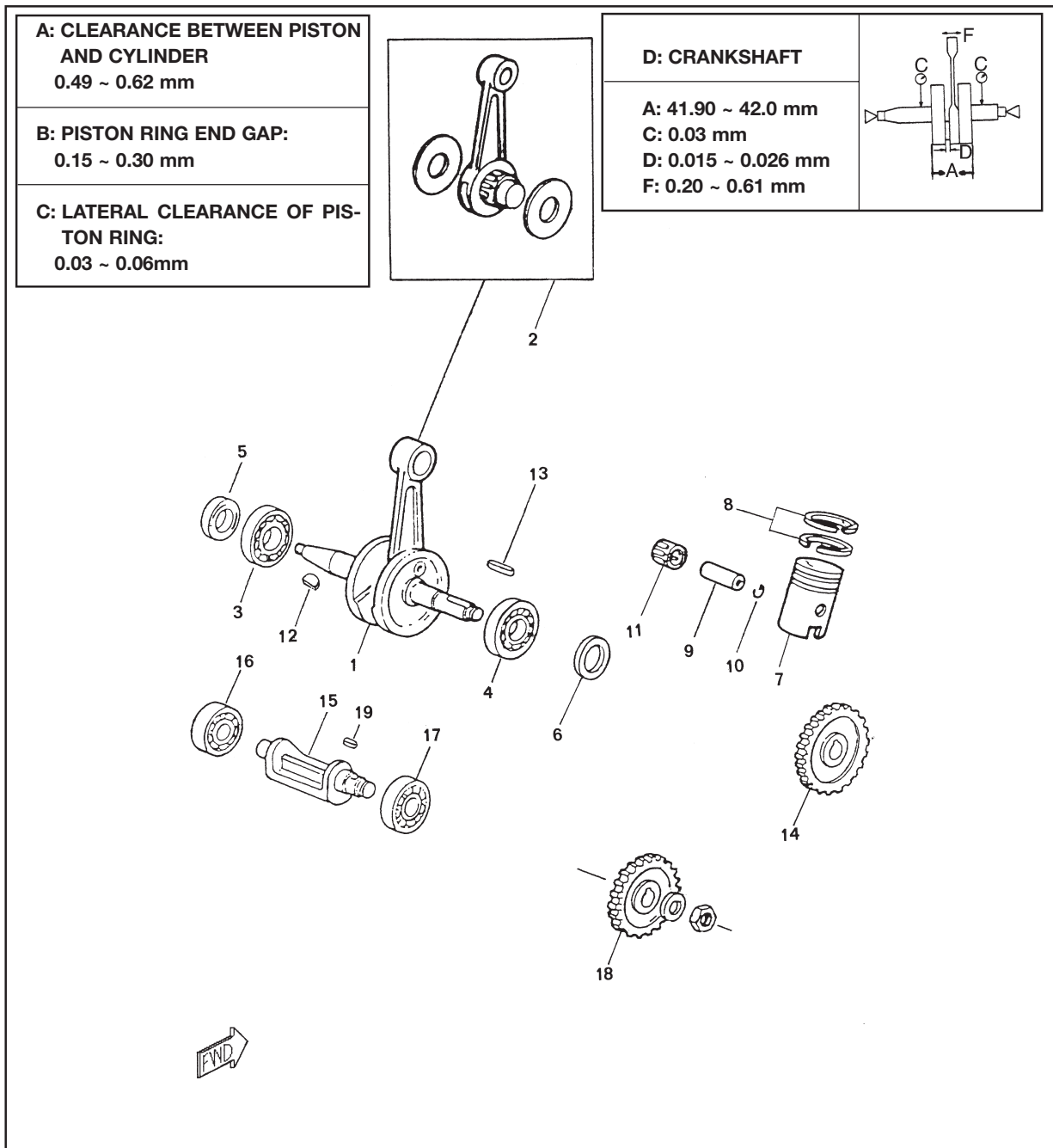

**CAUTION**

To protect the crankshaft from scratching or facilitate the installation operation, apply grease to the lips of the oil ring and engine oil on each bearing

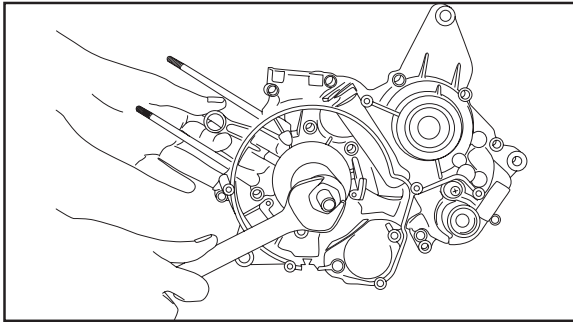

1. Position:
 - Crankshaft installing tool
(90890 - 01274, 90890 - 01278)
2. Assemble:
 - Crankshaft on the left-hand side of the crankcase.

NOTE:

Hold the con rod at top dead centre with one hand while you use your other hand to turn the nut of the tool until the crankshaft has gone all the way and touches the bearing.



SHIFT AND SELECTOR

SHIFT

- | | | |
|------------|------------------|------------|
| ① Primary | ⑩ Secondary | ⑲ Circlip |
| ② 5th gear | ⑪ 1st wheel gear | ⑳ Washer |
| ③ 3rd gear | ⑫ 5th wheel gear | ㉑ Washer |
| ④ 6th gear | ⑬ 4th wheel gear | ㉒ Circlip |
| ⑤ 2nd gear | ⑭ 3rd wheel gear | ㉓ Bearing |
| ⑥ Circlip | ⑮ 6th wheel gear | ㉔ Bearing |
| ⑦ Circlip | ⑯ 2nd wheel gear | ㉕ Seal |
| ⑧ Bearing | ⑰ Circlip | ㉖ Sprocket |
| ⑨ Bearing | ⑱ Washer | ㉗ Circlip |

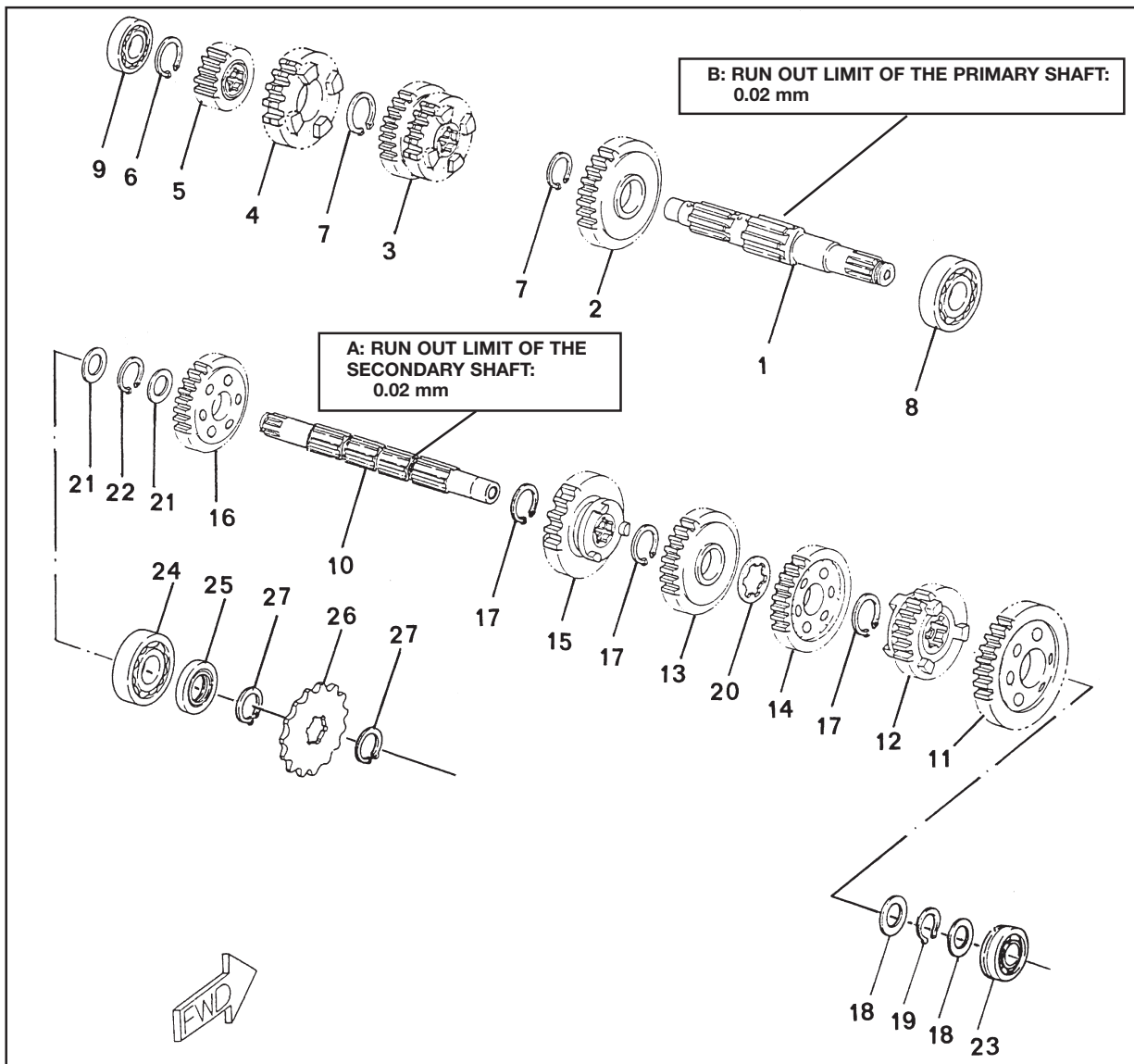



SELECTOR

- ① Shift drum
- ② Washer
- ③ Neutral
- ④ Spring
- ⑤ Ball
- ⑥ Shift fork 1
- ⑦ Shift fork 2
- ⑧ Shift fork 3
- ⑨ Shift fork guide bar 1
- ⑩ Shift fork guide bar 2
- ⑪ Washer
- ⑫ Nut

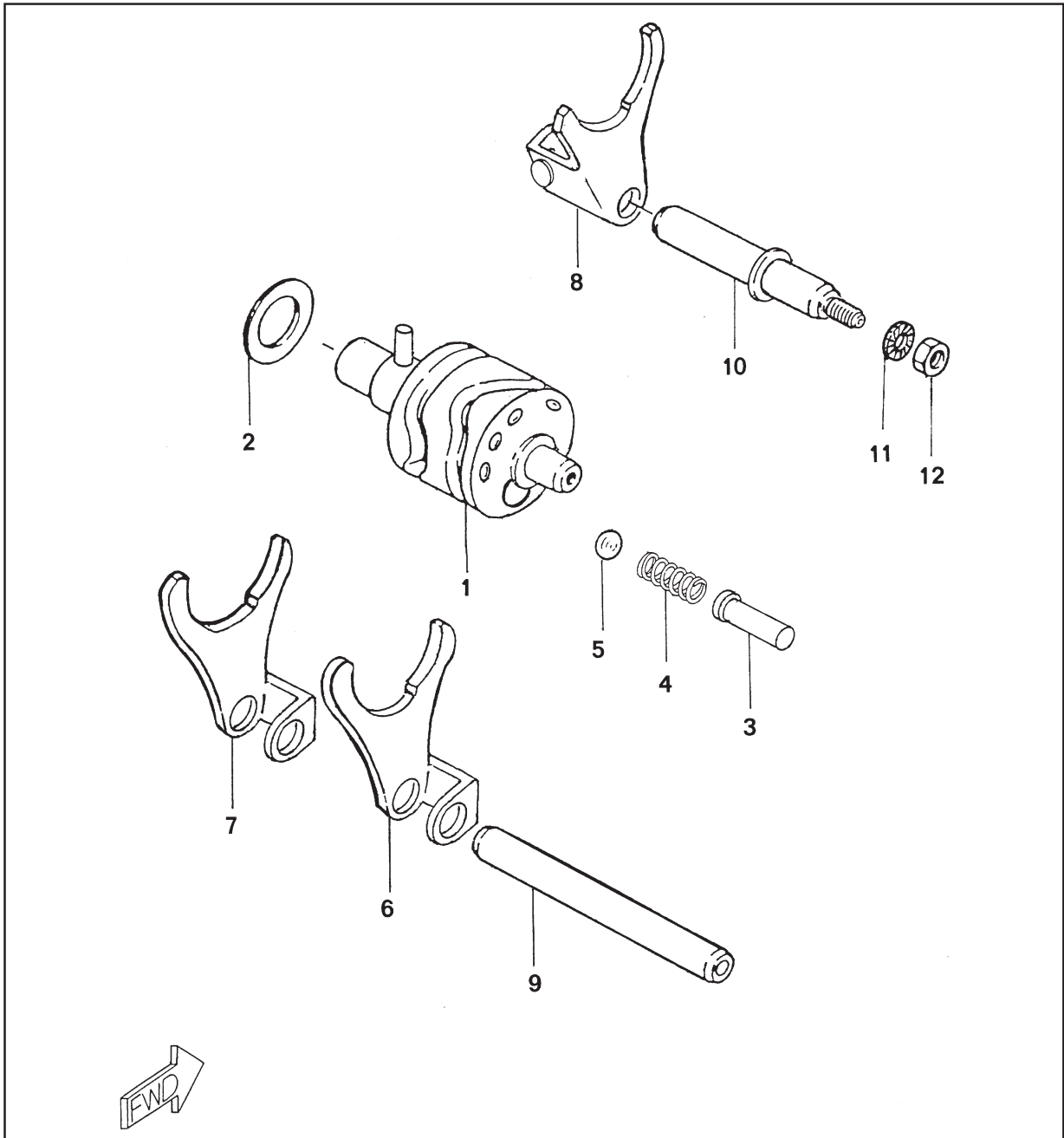

**NOTE:**

When you install the secondary shaft on the crankcase pay attention to the lip of the oil seal of the crankcase.

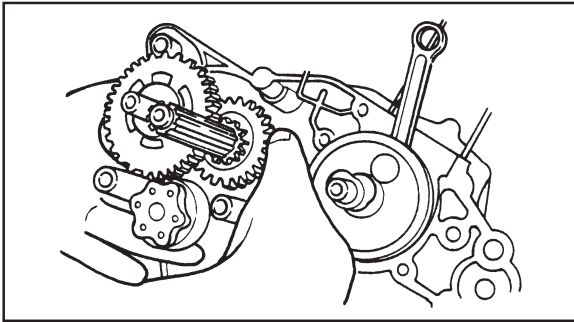

2. Install:
 - Secondary shaft, primary shaft, cam of the shift shaft, selector fork set, guide bars, selector and balancer shaft in the right-hand half of the crankcase.

NOTE:

It is highly important to follow the assembly sequence as stated in the breakdown of the "SHIFT AND SELECTOR" section.

3. Check:
 - Operation of the selector
 - Operates incorrectly → Repair

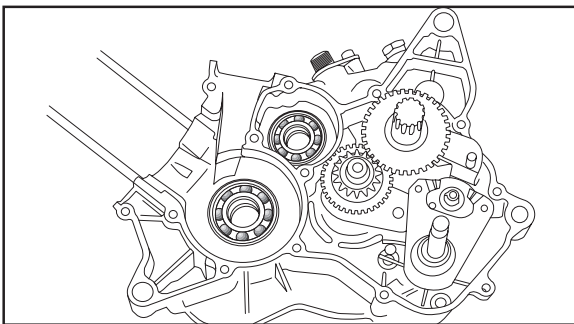
**CRANKCASE**

1. Apply:
 - Yamaha Bond n° 4 paste (90890-05143) on the sealing surfaces of the two halves.
2. Install
 - Locators ①
3. Install the left hand crankcase gently into the right. Gently tap the case in with a soft hammer.



CAUTION

Before installing and tightening the crankcase securing screws, do not forget to check if the shift works properly by manually turning the selector cam in both directions

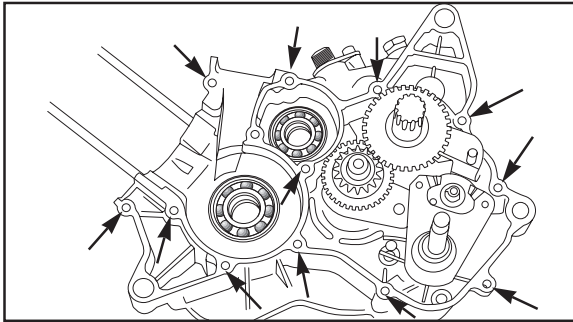

4. Tighten
 - Crankcase securing screws (following a crisscross pattern)



Crankcase securing screws :
1.0 m • kg

5. Apply:
 - 2 stroke engine oil to the crankshaft pin, bearing and oil feed bore.
6. Check:
 - Operation of the crankshaft and shift.
This works incorrectly → repair
7. Install:
 - Neutral switch

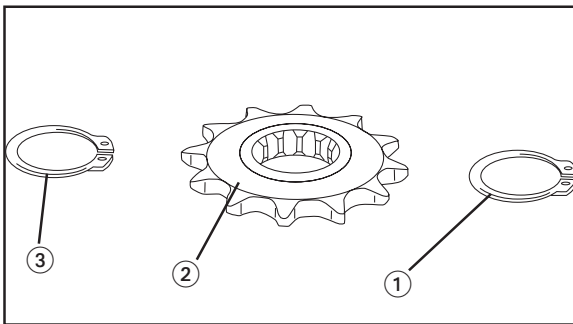

8. Install:
 - Circlip ①
 - Sprocket ②
 - Circlip ③



STARTER MOTOR

- ① Starter motor
- ② Screw
- ③ Magnetic flywheel
- ④ Screw
- ⑤ Nut

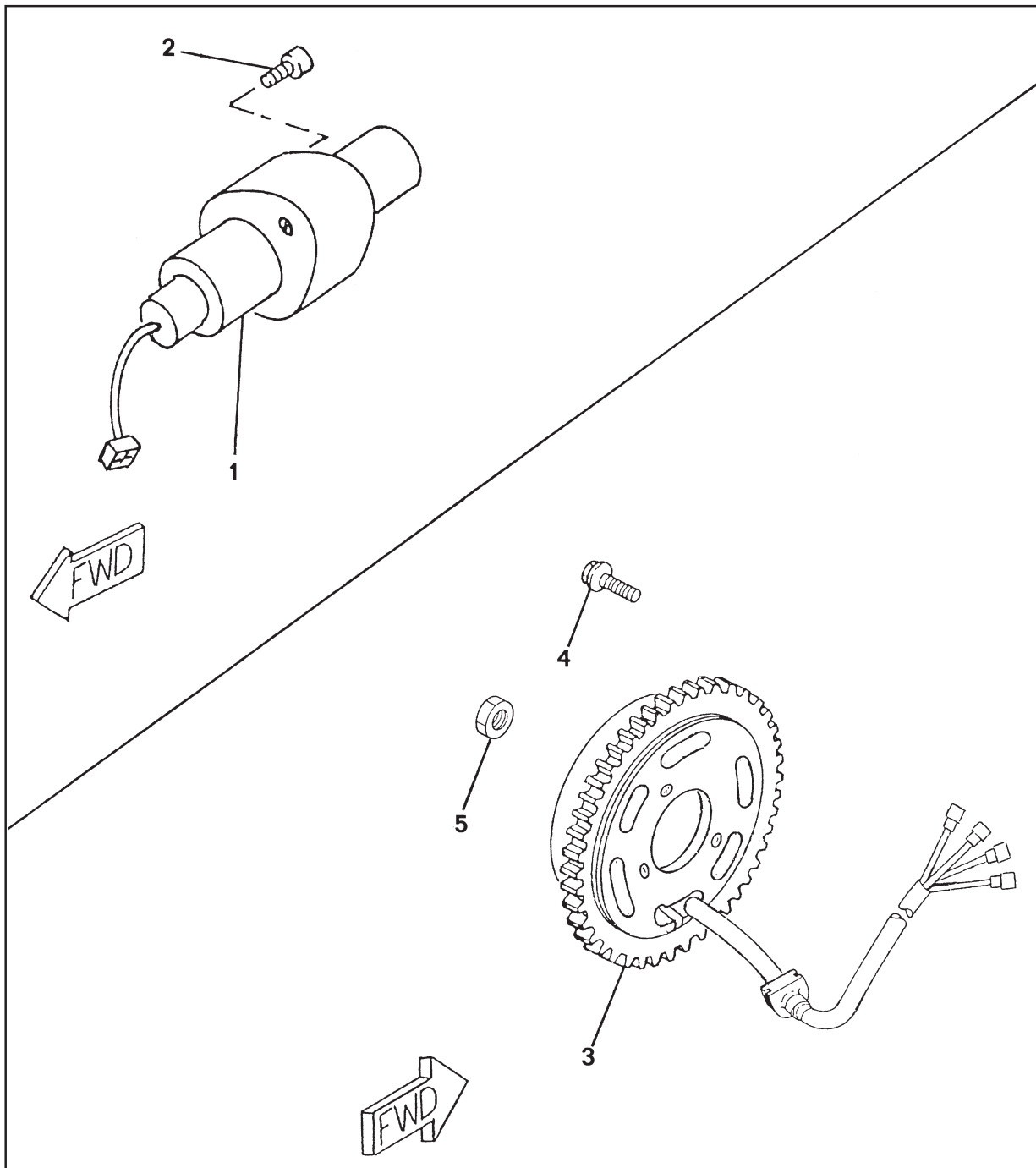

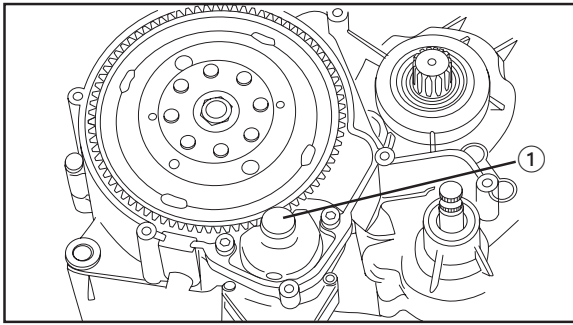

STARTER MOTOR

1. Install:
 - Starter motor ①

2. Install:
 - Coil plate in the crankcase



CAUTION

Install the coil holder plate so that the marks on the plate and on the crankcase, made during the dismantling process, coincide.

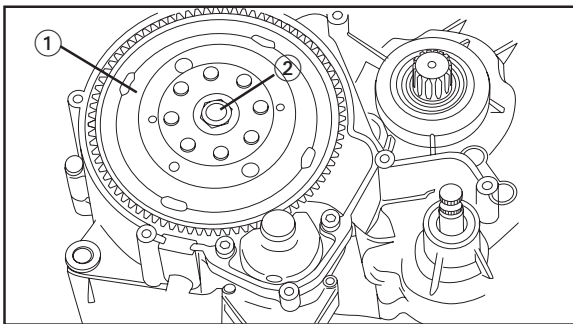

CDI MAGNETO

1. Install:
 - Coil plate
2. Install:
 - Key
 - CDI flywheel ①
 - Nut ②



CLUTCH AND PRIMARY DRIVE GEARING

- | | | |
|-------------------------|---------------------|--------------------|
| ① Primary drive gearing | ⑩ Pressure plate | ⑲ Tensor |
| ② Bush | ⑪ Spring | ⑳ Nut |
| ③ O ring | ⑫ Screw with washer | ㉑ Ball |
| ④ Nut | ⑬ Pusher plate | ㉒ Push rod 2 |
| ⑤ Clutch housing | ⑭ Conical washer | ㉓ Push lever shaft |
| ⑥ Thrust washer | ⑮ Conical washer | ㉔ Spring |
| ⑦ Clutch boss | ⑯ Nut | ㉕ Flat washer |
| ⑧ Friction disc | ⑰ Pusher plate | ㉖ Seal |
| ⑨ Clutch disc | ⑱ Push rod 1 | |

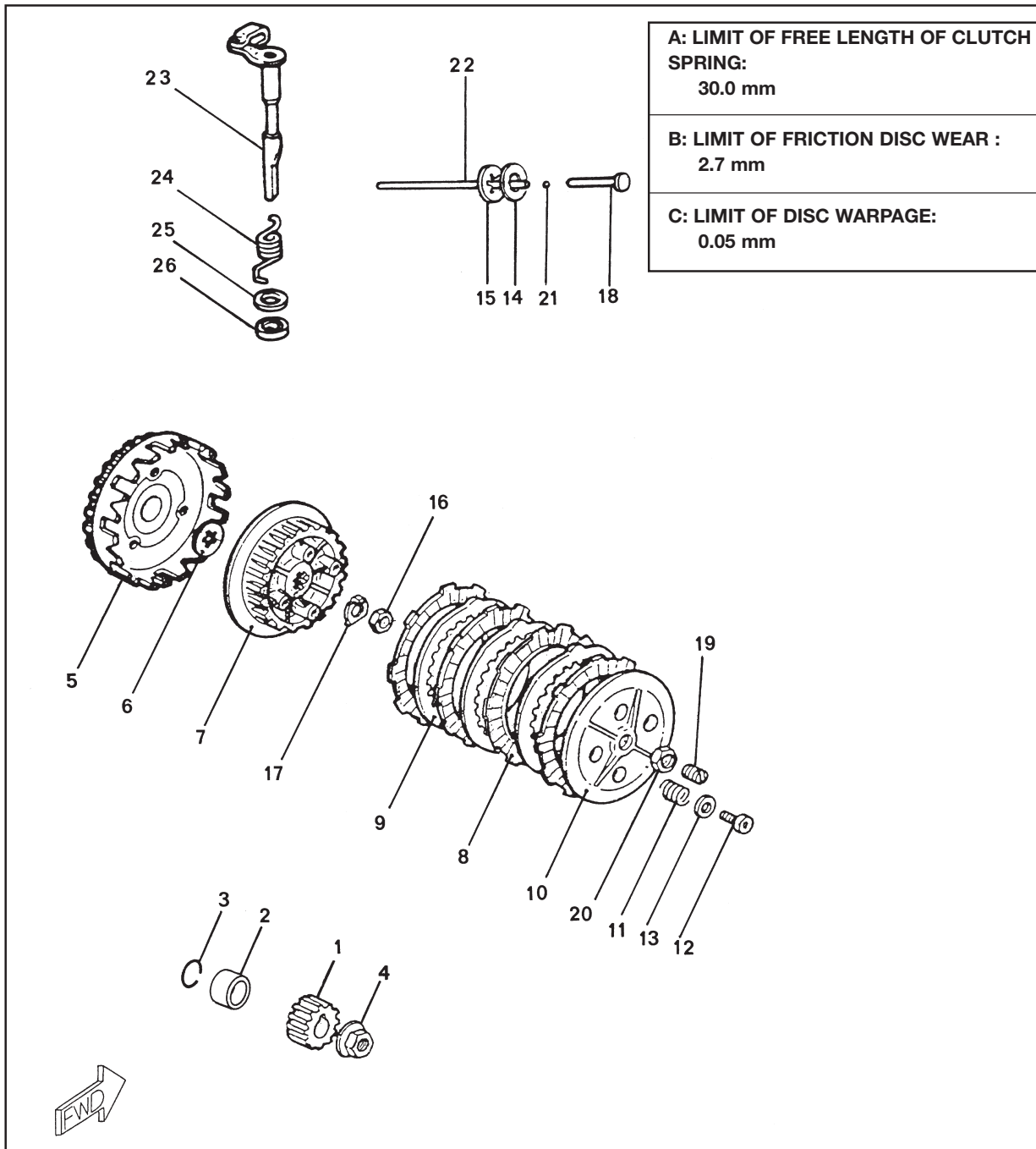



NOTE:

To tighten the CDI magneto nut use the flywheel holder 90890-01235 and without releasing this also tighten the nuts of the balancer shaft and that of the crankshaft gear



CDI magneto nut:
5.2 m • kg

Crankshaft gear nut:
6.0 m • kg

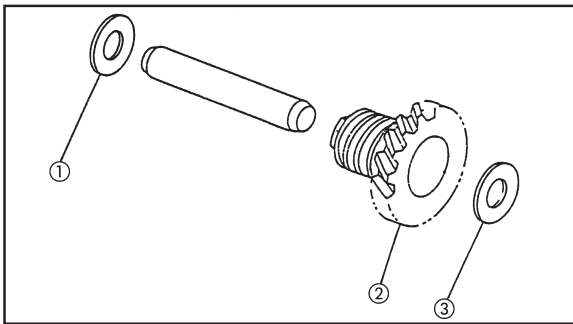

1. Install:
 - Washer ①
 - Tachometer gear ②
 - Washer ③

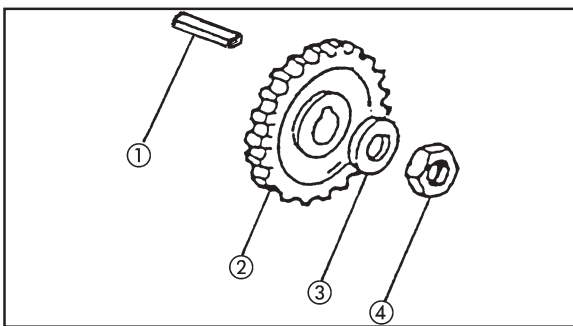

2. Install:
 - Key ①
 - Driven gear of balancer ②
 - Washer ③
 - Nut ④

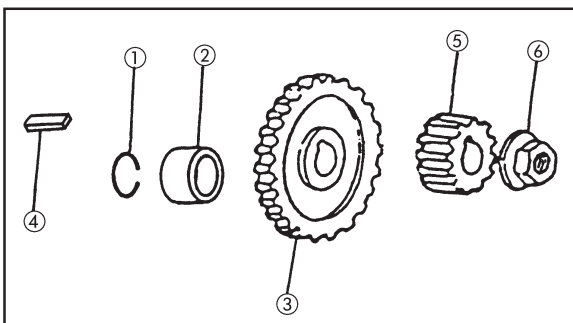

3. Install:
 - O ring ①
 - Bush ②
 - Drive gear ③
 - Key ④
 - Primary transmission gear ⑤
 - Nut ⑥

NOTE:

The driven and drive gears must have the two marks aligned

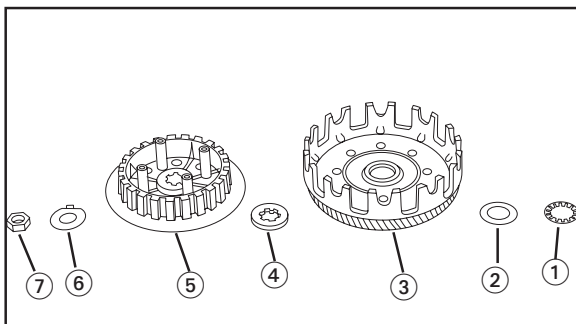

4. Install:
- Conical spring washer ①
 - Washer ②
 - Primary drive gear ③
 - Washer ④
 - Clutch boss ⑤
 - Washer ⑥
 - Clutch boss nut ⑦

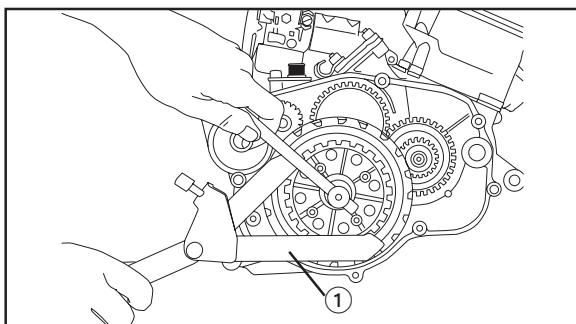

5. Tighten:
- Clutch boss nut
- Use the universal clutch holder ①



Clutch holder:
90890 - 04086
 To hold the clutch boss



Clutch boss nut
7.5 m • kg

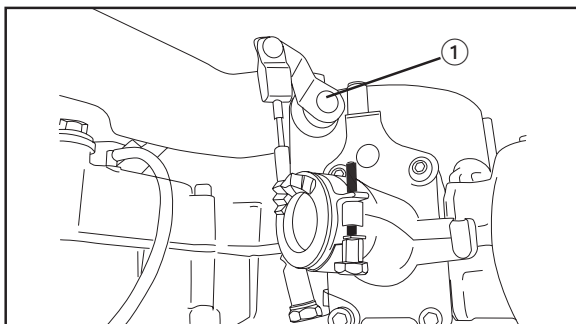

6. Install:
- Shaft assembly of the clutch push lever ①
 - Push rod n° ②
 - Ball of the push rod

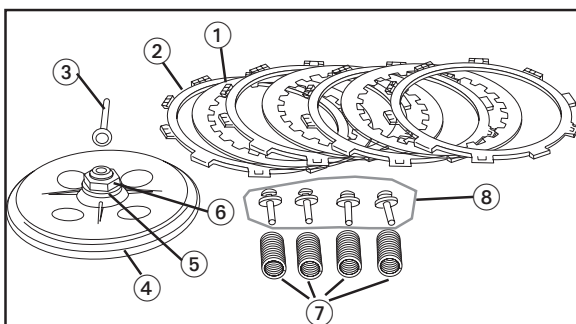

7. Install:
- Clutch discs ①
 - Friction discs ②
 - Push rod n° 1 ③
 - Pressure plate ④
 - Washer ⑤
 - Nut ⑥
 - Clutch springs ⑦
 - Screws for securing the clutch spring ⑧

NOTE: _____

- Install the clutch discs and the friction discs alternately in the clutch boss starting and ending with a friction disc
- Install the clutch discs so that each of these is 120° offset with the previous one.

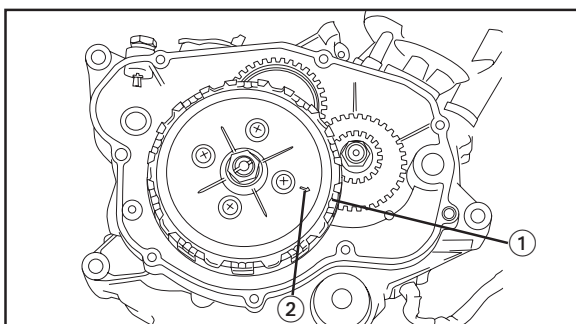

NOTE: _____

Line up the engraved mark ① of the clutch boss with the arrow ② of the clutch pressure plate.

	<p>Clutch spring securing screw: 0.4 m • kg</p>
--	--

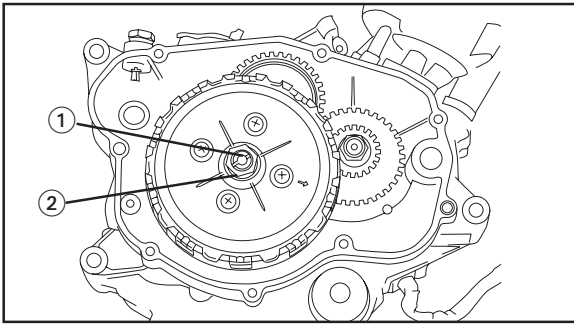

8. Adjusting the clutch lever:
 - Loosen locknut ②
 - Tighten the screw ① until it reaches the end
 - Loosen the screw ① 1/4 turn
 - Tighten the locknut ②

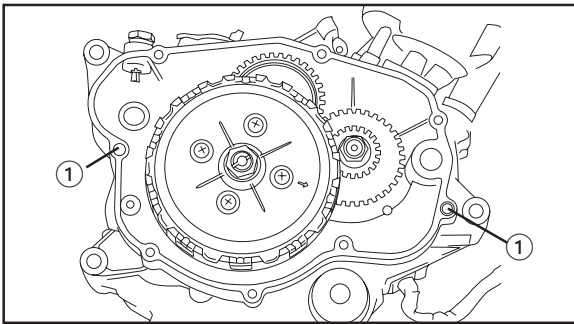

SHAFT OF THE WATER PUMP, SHAFT OF THE OIL PUMP AND RIGHT-HAND CRANK-CASE COVER

1. Install:
 - Locators ①
 - Gasket

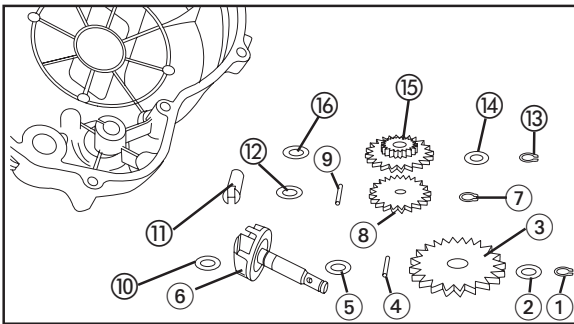

2. Install:
 - Washer ⑬
 - Intermediate gearing ⑮
 - Washer ⑭
 - Clip ⑬
 - Washer ⑫
 - Oil pump shaft ⑪
 - Washer ⑩
 - Pin ⑨
 - Driven gear of oil pump ⑧
 - Clip ⑦
 - Water pump shaft ⑥
 - Washer ⑤
 - Pin ④
 - Driven gear of water pump ③
 - Washer ②
 - Clip ①

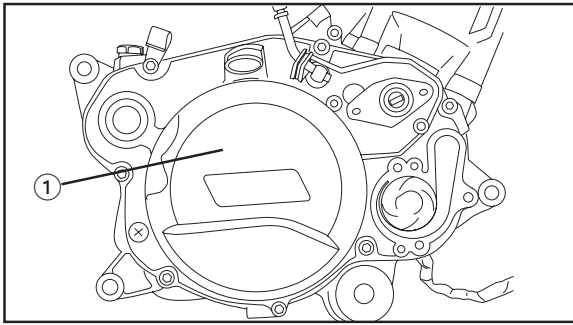

3. Install:
 - Right-hand crankcase cover ①
 - Screws

NOTE: _____

Tighten the securing screws of the crankcase cover following a crisscross pattern

	Screws of the crankcase cover: 1.0 m • kg.
--	--

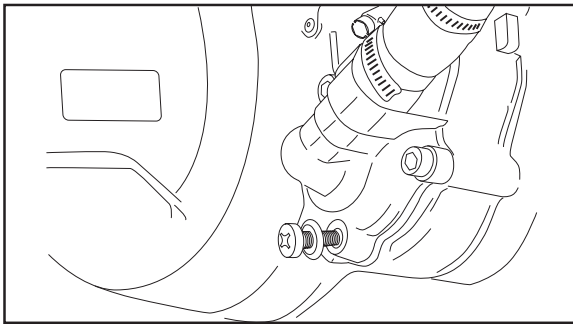

WATER PUMP COVER

1. Install:
 - Water pump cover gasket
 - Water pump cover
2. Install:
 - Screws for water pump cover

	Screws for the water pump cover: 0.5 m • kg
--	---

NOTE: _____

Use a new washer on the coolant drain screw

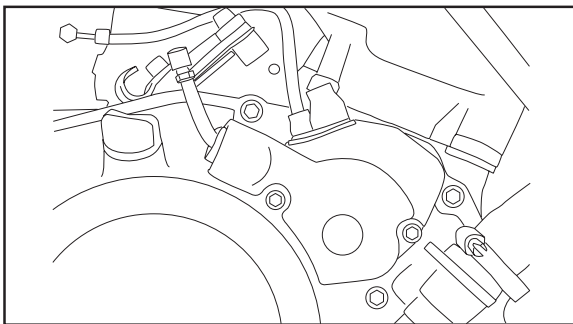

OIL PUMP

1. Install:
 - Oil pump assembly

	Pump securing screw: 0.7 m • kg
--	---

- Oil pump cover

	Cover securing screw: 0.7 m • kg
--	--

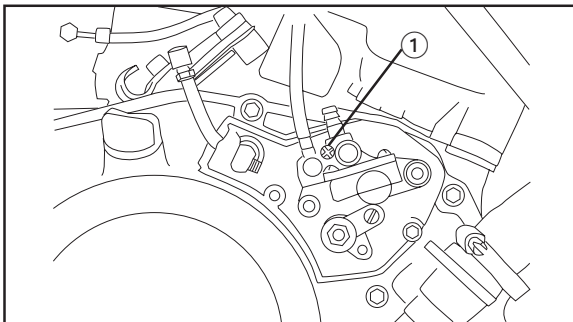

2. Connect:
 - Tube for oil supply to the carburettor
 - Tube for oil inlet to the pump
3. Bleed:
 - Lubrication pump (bleed screw ①)



PISTON PIN AND PISTON

1. Apply:
 - 2 stroke engine oil
To the piston pin, bearing, piston ring slots and piston

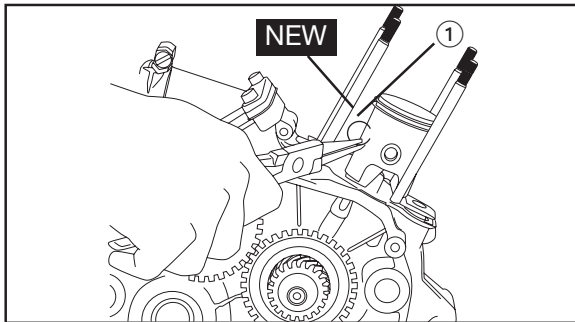

2. Install:
 - Con rod little end bearing
 - Piston
 - Piston pin
 - Piston pin clip ①

NOTE:

- The arrow marked on the piston must point to the front of the engine
- Before installing the piston pin clip, cover the crankcase with a clean cloth so that neither the piston clip nor anything else can fall inside the crankcase.
- Always use a new piston pin clip



CYLINDER HEAD AND CYLINDER

- ① Cylinder
- ② Spark plug
- ③ Water pipe
- ⑦ Head gasket
- ⑧ Head gasket
- ⑨ Nut
- ⑩ Flat washer
- ⑪ Cylinder
- ⑫ Cylinder gasket
- ⑬ Thermostat

A: SPARK PLUG GAP: 0.6 ~ 0.7 mm
B: STANDARD SPARK PLUG: BR9ES (NGK)
2.0 m • kg

C: LIMIT OF CYLINDER HEAD WAR- PAGE: 0.03 mm
--

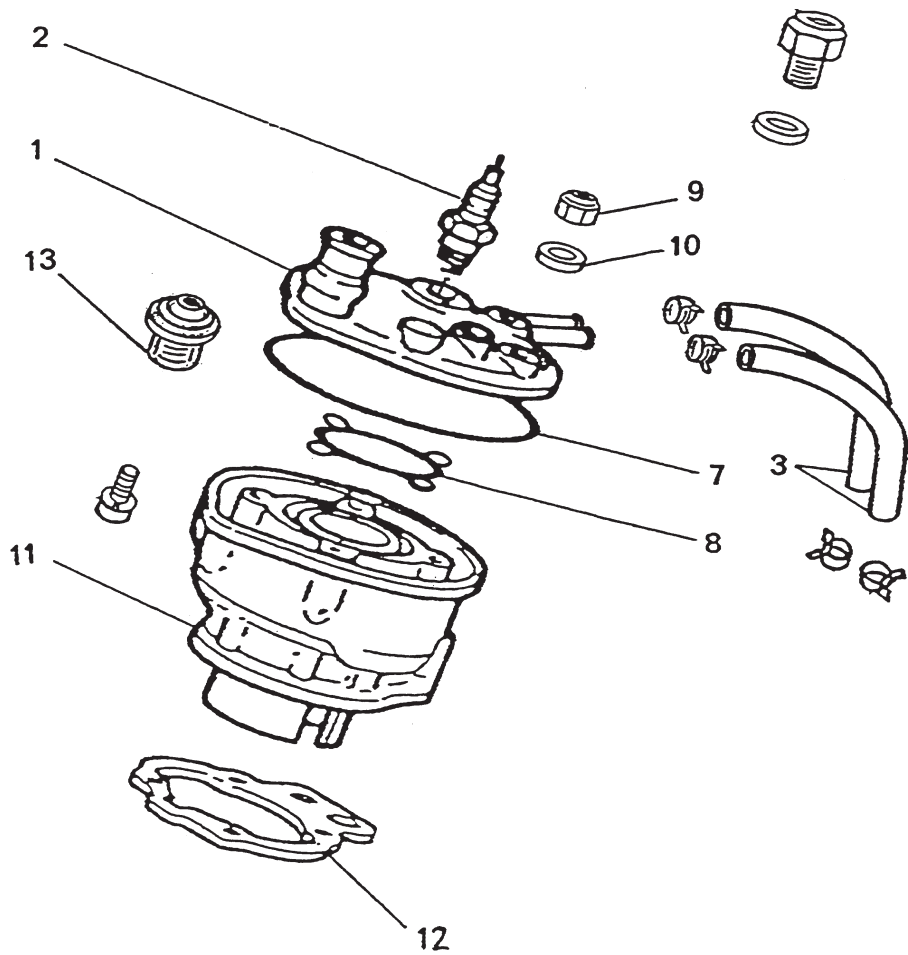

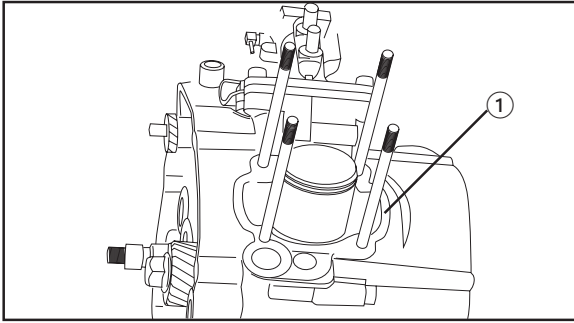

1. Install:
 - Cylinder head gasket ①

NOTE: _____

- Make sure that the mark and manufacturer number engraved on the rings are on the top side of these.
- Before installing the cylinder, apply a good layer of 2 stroke engine oil to the piston rings.

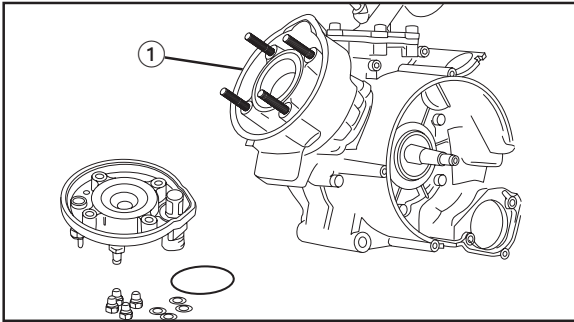

2. Install:
 - Cylinder ①

NOTE: _____

Install the cylinder with one hand while you tighten the piston rings with the other.

3. Install:
 - Locators (2 units)
 - O rings
 - Thermostat



⚠ WARNING

Handle the thermostat with special care. Never hold this tightly or drop it. If it falls replace it with a new one.

5. Install:
 - Cylinder head
 - Washers
6. Tighten:
 - Cylinder head nuts

	Tightening torque for cylinder head nuts: 2.2 m • kg
---	---

NOTE:

Tighten the cylinder head nuts in a crisscross pattern.

7. Install:
 - Thermocontact
8. Install:
 - Reed valve assembly

NOTE:

Tighten the screws for securing the reed valve in a crisscross pattern

	Reed valve securing screw: 0.8 m • kg
---	--

9. Install:
 - Carburetor
 - Connect all the pipes (oil, water, etc.).
 - Starter cable
10. Install:
 - C.D.I. magnetic flywheel cover

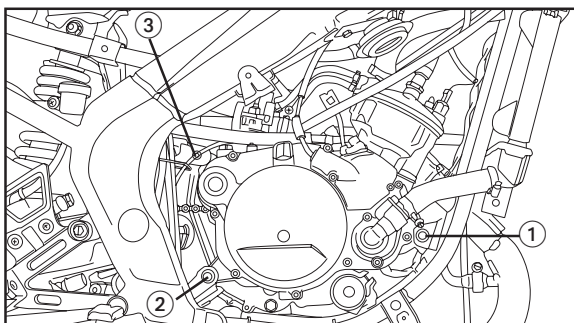

INSTALLING THE ENGINE

When you install the engine, follow the removal process inversely. Pay attention to the following points.

1. Install:
 - Engine assembly screws

	Engine assembly screws ①, ②, ③: 3.0 m • kg
---	---

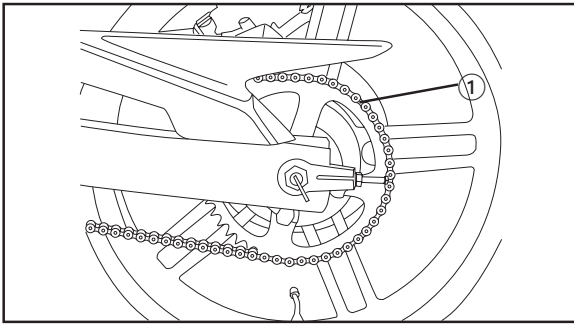

2. Install:
 - Drive chain ①

NOTE: _____

After installing the drive chain adjust the tension of the chain. See “ADJUSTING CHAIN” in Chapter 6.

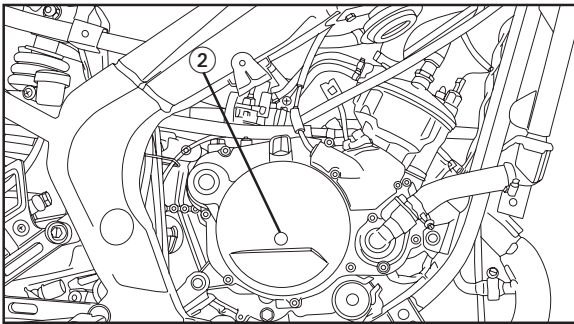

3. Install:
 - Crankcase cover 2 (left)

	Screws for securing crankcase cover 2 0.5 m • kg
--	--

- Output gear cover

	Screws for securing output gear cover 0.5 m • kg
--	--

- Shift cam

	Shift cam screw. 0.6 m • kg
--	---------------------------------------

4. Install:
 - Oil pump cover

	Pump cover securing screw: 0.4 m • kg
--	---

- Spark plug

	Spark plug: 2.0 m • kg
--	----------------------------------

- Exhaust pipe

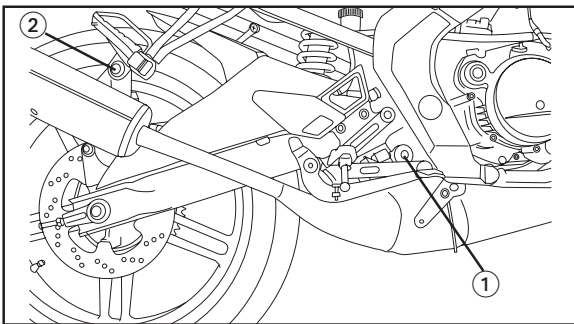

	Screws for securing the exhaust pipe to the chassis: 2.1 m • kg ① 3.0 m • kg ②
--	---

- Springs ③
- AIS pipe ④

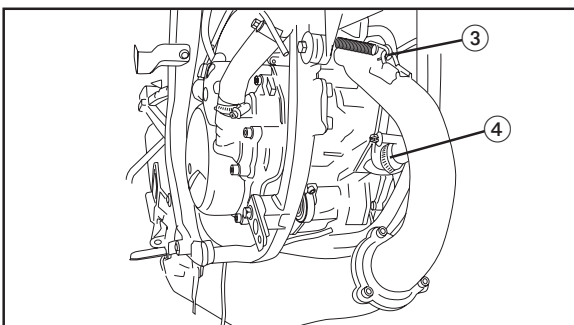

	Screw for the clamp of the AIS tube: 0.4 m • kg
--	---

5. Add:
 - Transmission oil
 - Coolant

	Transmission oil: total: 0.82 L Total amount of coolant: 0.7 L
--	---



6. Inspect:
 - Oil leaks
 - Coolant leaks
7. Connect:
 - Neutral cable

NOTE: _____

Before starting the engine up, bleed the lubrication system.

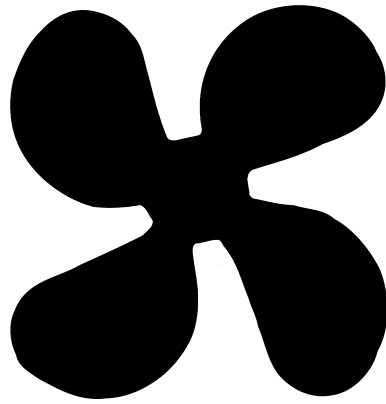

COOL

5



CHAPTER 5 COOLANT SYSTEM

CHANGING THE COOLANT5-1

WATER PUMP5-3

 DISMANTLING5-4

 INSPECTION.....5-5

 ASSEMBLY5-6

THERMOSTAT AND RADIATOR5-8

 INSPECTION5-9

 ASSEMBLY5-10



COOLING SYSTEM

COOLANT

CHANGING THE COOLANT

⚠ WARNING

Do not remove the radiator cap while this and the engine are hot. Boiling liquid and vapour could emerge with consequent danger of serious injury. When the engine has cooled off, open the radiator tap as follows: place a thick cloth, for example a towel, over the cap and turn this as far as it will go, slowly, to the left. This procedure will let any residual pressure release. When the whistling sound has stopped, tighten the cap downwards making it turn left at the same time to open it

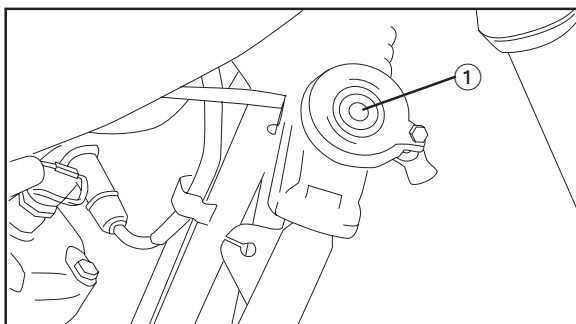

1. Place an open recipient under the engine.
2. Wait until the radiator cools down.
3. Take off:
 - Radiator cap ①
4. Remove:
 - Drain screw ②
5. Drain:
 - Coolant (completely)

NOTE:

Fully wash out the cooling system with clean water.

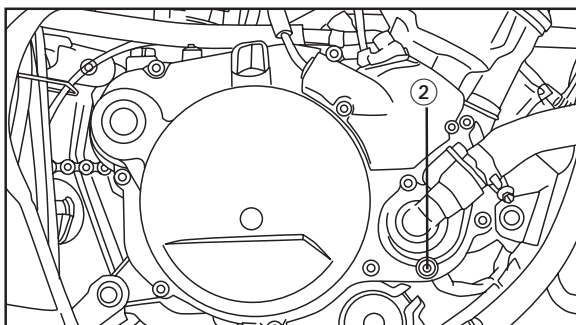

6. Inspect:
 - Gaskets (drain screw)
Damaged → Change
7. Tighten:
 - Drain screw (water pump cover)



Drain screw (water pump cover):
1.4 m • kg

8. Fill up with:
- Coolant liquid (in the radiator)



Recommended coolant:
High quality ethylene glycol anti-freeze solution containing anti-corrosive materials for aluminium alloy engines.
Proportion for mixing coolant and water:
50% / 50%
Total volume:
0.71 L
Capacity of expansion tank:
0.42 L
From “LOW” level to “FULL” level:
0.18 L

CAUTION

Water with impurities is harmful for the engine. If you cannot get distilled water, use boiled water.

Do not mix more than one type of ethylene glycol antifreeze containing anti-corrosives for aluminium engines.

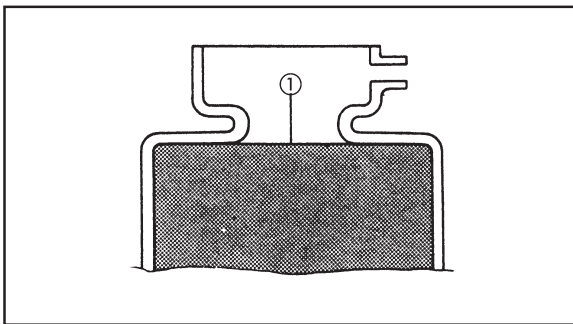

9. Install:
- Radiator cap
10. Start the engine up for a few minutes.
11. Inspect:
- Coolant level ① in the radiator
Low level → Fill up (to the top of the radiator)
12. Fill up with:
- Coolant
 - Top up the coolant up to the “FULL” level in the expansion tank.
13. Install:
- Radiator cap
14. Inspect:
- Coolant system
Leakage of coolant → Repair

CAUTION

Before starting up the engine, always check the coolant level and see if there are any leakages of this.



**COOLING SYSTEM
WATER PUMP**

- ① Impeller shaft
- ② Oil seal
- ③ Pin
- ④ Washer
- ⑤ Circlip
- ⑥ Impeller shaft gear
- ⑦ Cover of the water pump body
- ⑧ Locator
- ⑨ Gasket
- ⑩ Screw
- ⑪ Screw
- ⑫ Drain screw
- ⑬ Gasket
- ⑭ Connection
- ⑮ O ring
- ⑯ Screw

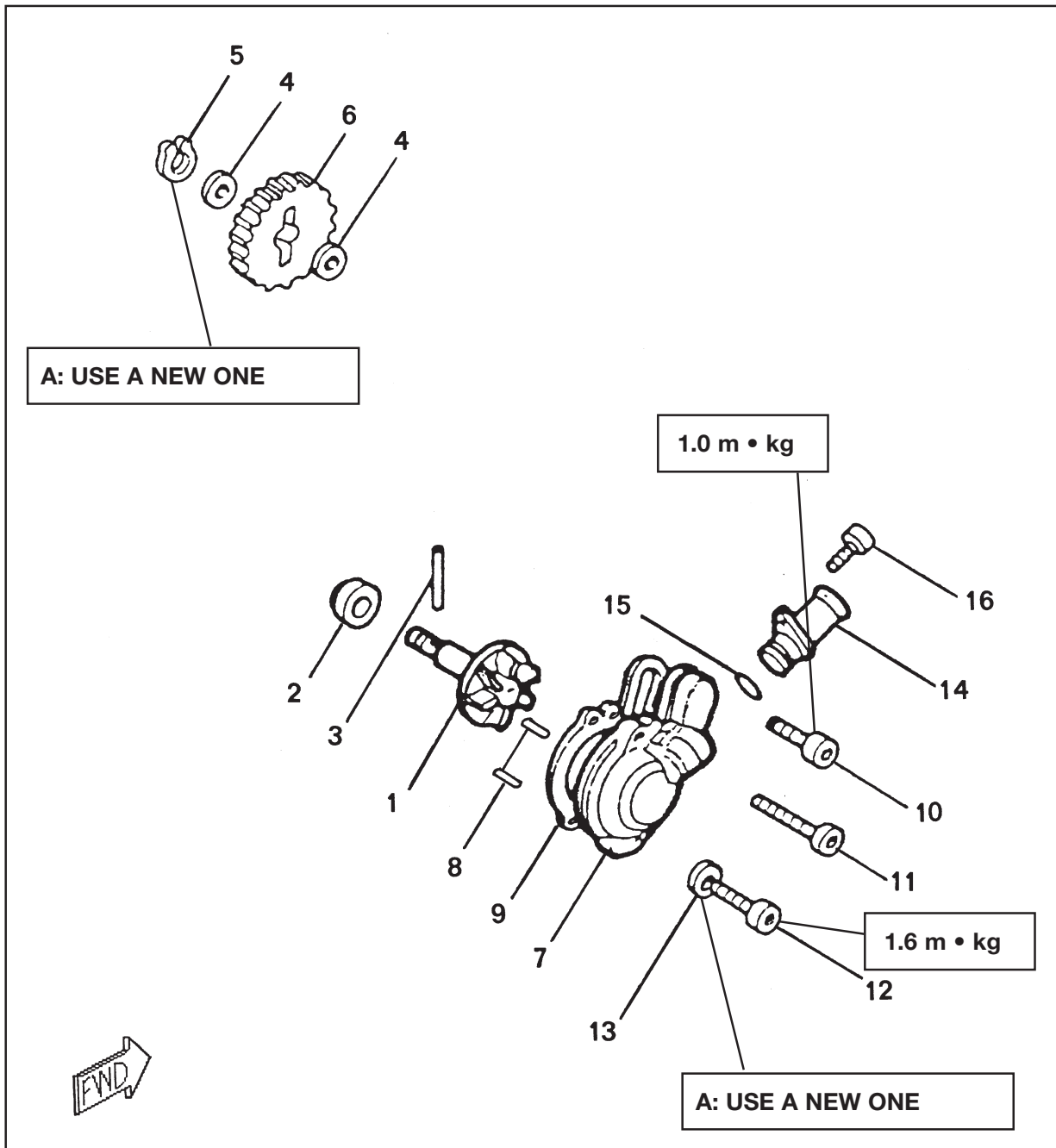



DISMANTLING

NOTE:

There is no need to dismantle the water pump unless anomalies have been observed, such as excessive variations in temperature and/or volume of the coolant liquid, its decolouring or a milky look to the transmission oil.

1. Drain:

- Crankcase
See the section on “CHANGING THE TRANSMISSION OIL” in CHAPTER 3.
- Cooling system
See the section on “CHANGING THE COOLANT” in CHAPTER 3.

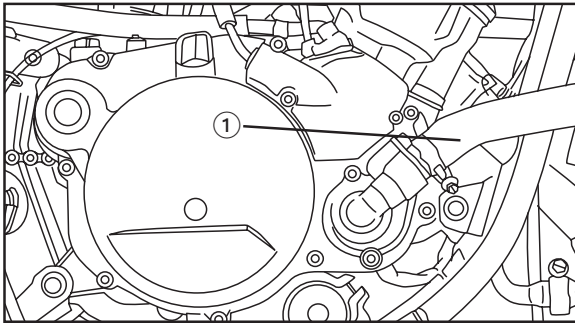

2. Remove:

- The output hose ①

WATER PUMP

COOL

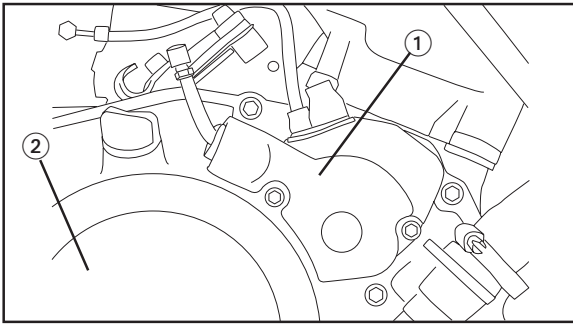

3. Dismantle:
 - The cover of the water pump body (1)
 - The crankcase cover (2)

CAUTION

Remove the coolant from the water pump taking care that this does not splash the autolube pump.

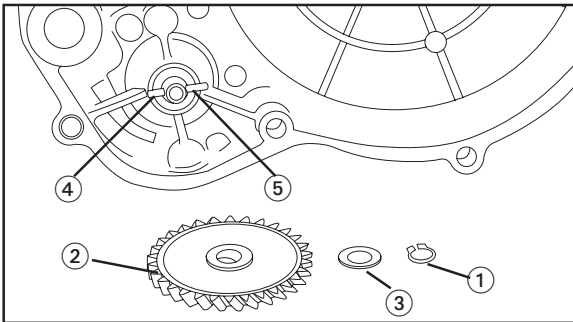

4. Dismantle:
 - The circlip (1)
 - The gear of the impeller shaft (2)
 - The flat washer (3)

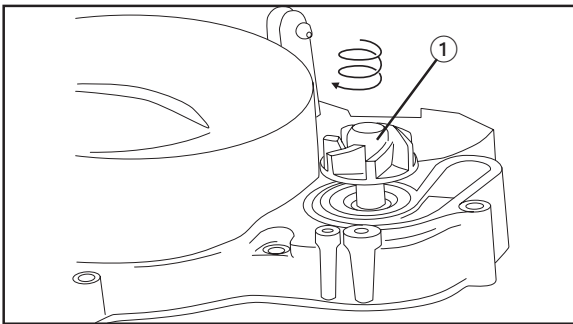

5. Dismantle:
 - The pin (4)
 - The flat washer (4)
6. Dismantle:
 - The impeller shaft (1)
7. Eliminate any deposits incrustated on the shaft and the body of the water pump

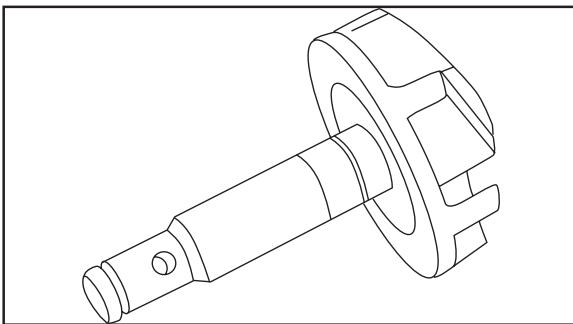

INSPECTION

1. Inspection
 - The impeller
 - Cracks/wear/damage → replace

WATER PUMP

COOL

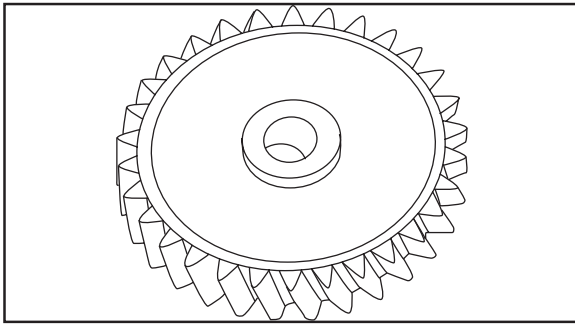

2. Inspect:
 - The gear of the impeller shaft
Cracks/Wear/Damage → replace

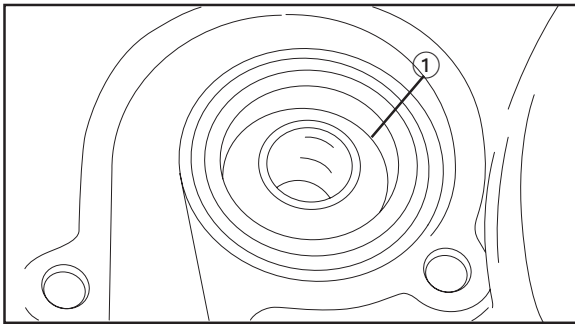

3. Inspect:
 - The seal ①
Wear / Damage → Replace

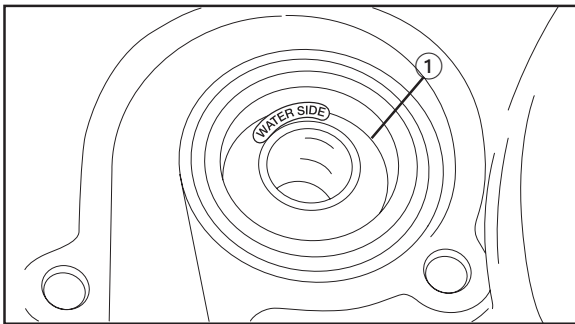

Replacement steps:

- Remove the seal from the crankcase cover, tapping this lightly outwards.
- Install the new seal, with the “WATER SIDE” mark ① outwards.

NOTE:

- Apply light lithium grease to the outside of the oil seal.
- Press install the seal until it comes into contact with the base

ASSEMBLY

Apply the “DISMANTLING” procedure inversely, bearing in mind the following points:

1. Apply:
 - Light lithium grease to the lips of the seal and to the impeller shaft

WATER PUMP

COOL

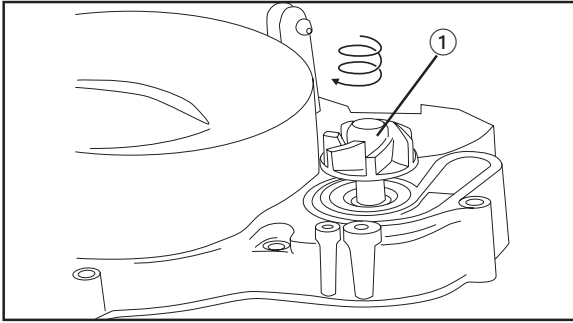

2. Install:
 - The impeller shaft ①Turn the shaft during assembly

NOTE: _____

Proceed with care so as not to damage the lip of the seal and so that the spring does not come out of position

3. Install:
 - The crankcase cover (right hand)
 - The cover of the water pump body



Screw (crankcase cover):

0.5 kg • m

Screw (water pump body cover):

0.5 kg • m

CAUTION _____

Always use new gaskets

4. Fill up:
 - The transmission oil
See the section on “CHANGING THE TRANSMISSION OIL” in CHAPTER 3.
 - The coolant. See the section on “CHANGING THE COOLANT” in Chapter 3.
5. Bleed the air:
 - Autolube pump
 - See the section on “BLEEDING THE AIR FROM THE AUTOMATIC MIXING PUMP” in CHAPTER 3.



THERMOSTAT AND RADIATOR

- ① Radiator
- ② Cap
- ③ Stop
- ④ Bolt
- ⑤ Washer
- ⑥ Protector ring
- ⑦ Bush
- ⑧ Protector ring
- ⑨ Screw
- ⑩ Washer

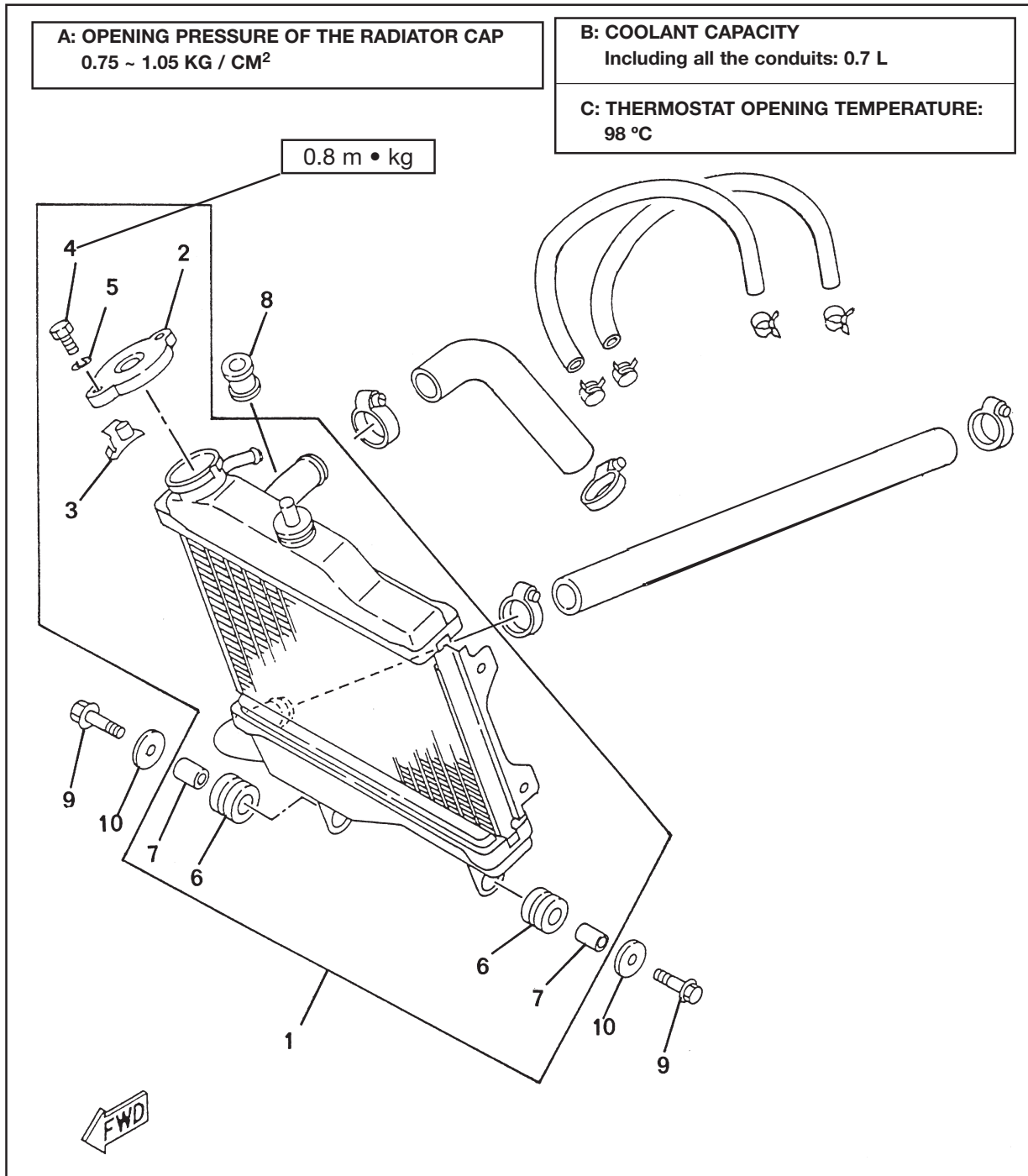

THERMOSTAT AND RADIATOR

COOL

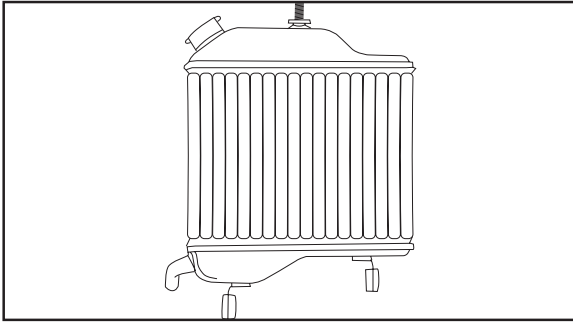

INSPECTION

1. Inspect:
 - The radiator core
 - Obstruction → Eliminate this with compressed air, blowing from the rear of the radiator.
 - Squashed fins → repair / replace
2. Inspect:
 - The inlet hose
 - Cracks / damage → Replace
 - Output sleeve
 - Cracks / Damage → Replace
3. Measure:
 - The opening pressure of the radiator cap

Radiator cap opening pressure:
0.75 ~ 1.05 kg/cm²

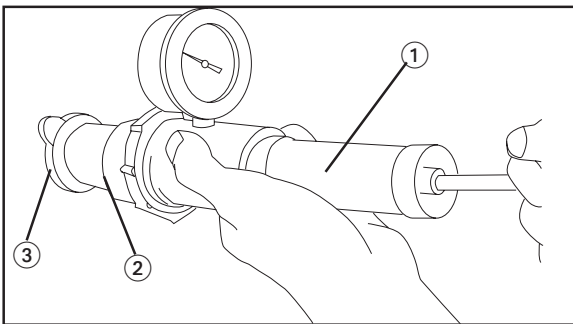

Measurement steps:

- Connect the tester ① of the cooling system and the adapter ② to the radiator cap ③.



Cooling system tester:
90890 - 01325
Adapter:
90890 - 01352

- Apply the specified pressure for ten seconds and make sure that this does not drop.

4. Inspect:
 - The thermostat
 - See the section on “DISMANTLING THE ENGINE” in CHAPTER 4 CYLINDER HEAD AND CYLINDER
 - The valve does not open → replace

THERMOSTAT AND RADIATOR

COOL

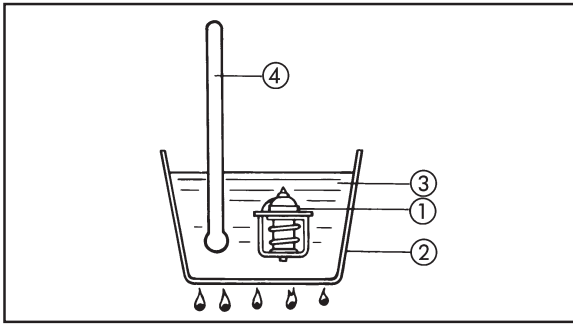

Inspection steps:

- Hang the thermostat ① in a recipient ②
- Submerge a reliable thermometer in water ③
- Heat up the water slowly
- Observe the thermometer ④ without ceasing to agitate the water

NOTE:

The thermostat is sealed and rating this is a job for a specialist. If you have any doubts about its accuracy, replace it. A faulty valve could cause very harmful overheating or overcooling.



Screws (of the thermostat):
2.0 kg • m

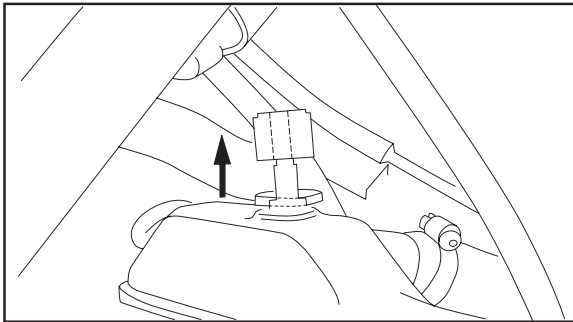

ASSEMBLY

Follow the same procedure as in “DISMANTLING” but inversely.

Take into account the following points.

1. Tighten:
 - The screws (of the thermostat)

2. Assemble:
 - The radiator

3. Tighten:
 - The screws (radiator)



Screws (radiator):
0.6 kg • m

THERMOSTAT AND RADIATOR

COOL



4. Fill up:
 - The coolant
See the section on “CHANGING THE COOLANT” in CHAPTER 3.
5. Inspect:
 - The cooling system
Reduce the pressure (leaks) → Repair as required.

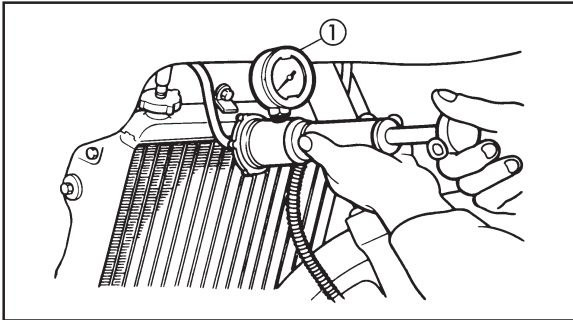

Inspection steps:

- Connect the cooling system tester ① to the radiator



Cooling system tester:
90890 - 01325

- Apply 1.0 kg/cm² pressure
- Measure the pressure with the manometer.

6. Install:
 - The seat

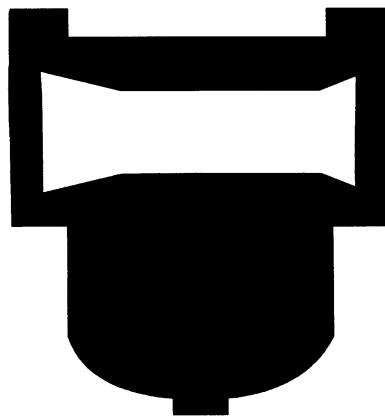

CARB

6



CHAPTER 6 CARBURATION

CARBURETOR6-1
 REMOVAL6-2
 DISMANTLING6-2
 INSPECTION.....6-2
 ASSEMBLY6-3
 INSTALLATION6-3
 ADJUSTING THE PETROL LEVEL6-3

REED VALVE6-4
 REMOVAL6-4
 DISMANTLING6-4
 INSPECTION.....6-4
 ASSEMBLY6-5
 INSTALLATION6-6



CARBURATION
CARBURETOR

- ① Carburetor
- ③ Carburetor cover
- ④ Needle valve
- ⑦ Float chamber
- ⑧ Main jet
- ⑨ Diffuser
- ⑩ Idling jet
- ⑭ Spring
- ⑬ Casing
- ⑮ Choke jet
- ⑲ Idling screw
- ⑳ Float pin
- ㉑ Float

SPECIFICATIONS	
Main jet (M.J.)	# 88
Pilot air screw (P.A.S.)	2 1/8
Fuel level (F.L.)	13 ~14 mm
Idling speed	1850 ± 150

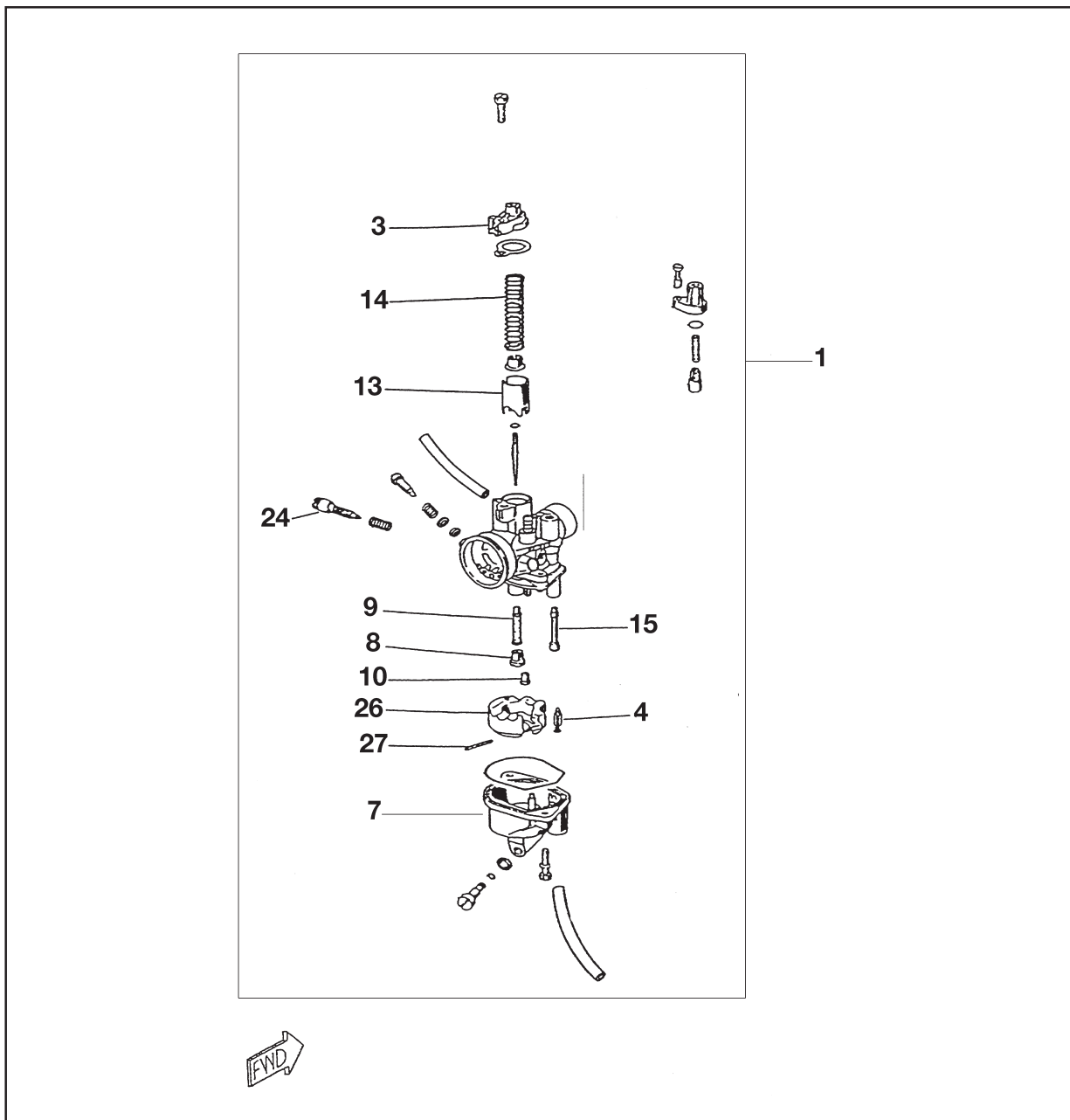



REMOVAL

- Remove:
 - Carburetor assembly
 See the section on engine removal

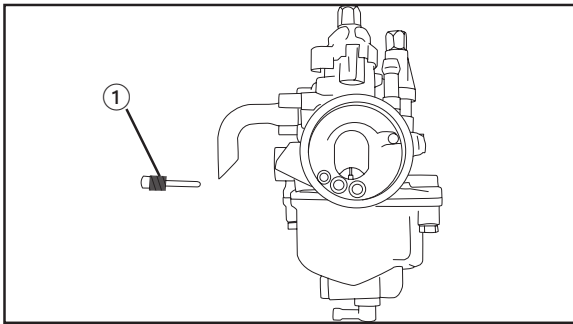

DISMANTLING

- Remove:
 - Idling stop screw (1)

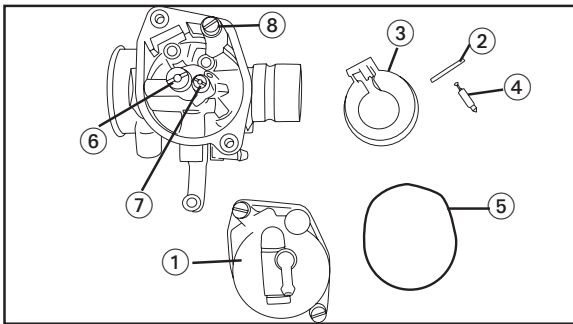

- Remove:
 - Float chamber (1)
 - Float pin (2)
 - Float (3)
 - Water valve (4)
 - Gasket (5)
 - Main jet (6)
 - Idling jet (7)
 - Choke jet (8)

INSPECTION

- Inspect:
 - Carburetor body
 Dirty → clean

NOTE:

Use a petroleum type solvent for cleaning. Clean all the holes and jets with compressed air.

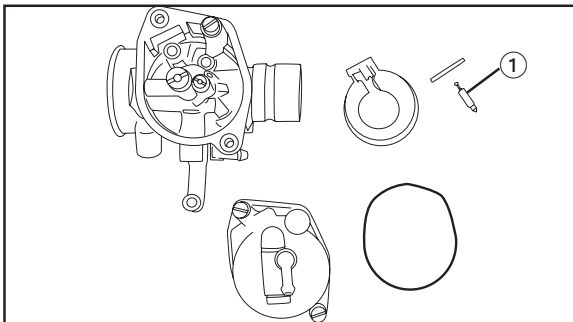

- Inspect:
 - Valve seat / float valve (1)
 Wear / Dirt → Change

NOTE:

Always change the float chamber valve and valve seat as a set.

CARBURETOR

CARB

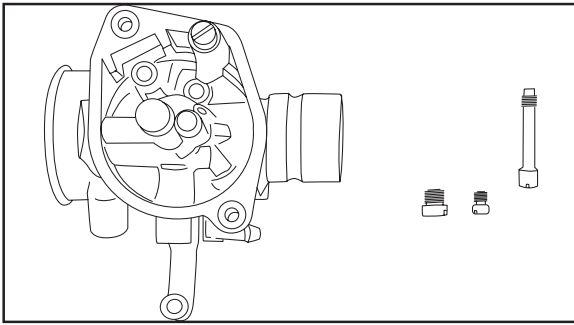

3. Inspect
 - JetsWear / Dirt → Change / Clean

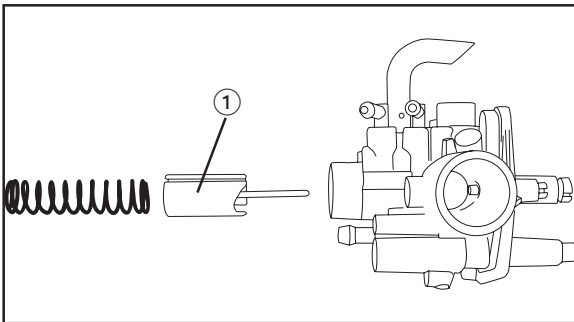

4. Inspect:
 - Plunger ①
 - Wear/damage → Replace
5. Check:
 - Free movementDifficulty → Change
Insert the plunger into the carburetor body.
6. Inspect
 - FloatDamaged → Change
 - O ringDamaged → Change

ASSEMBLY

1. Install:
 - Follow the dismantling procedure inversely

INSTALLATION

1. Install:
 - Carburetor assemblyApply the removal procedure inversely

ADJUSTING THE FUEL LEVEL

1. Measure:
 - Float heightOutside specifications → Service



Float height (FH) :
13 -14 mm



Adjustment steps:

- Take out the carburetor
- Inspect the valve seat and the float chamber valve.
- If either of the two parts is worn, change both.
- Check the petrol level again

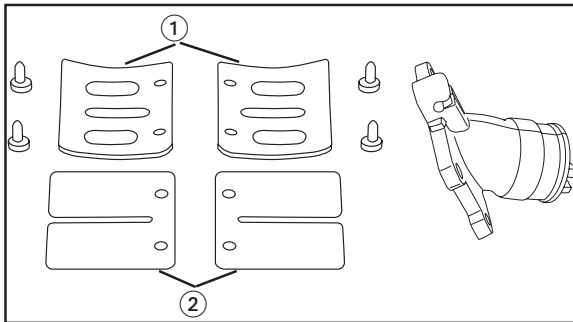

REED VALVE

REMOVAL

1. Remove:
 - Reed valve assembly
 See the engine removal section

DISMANTLING

1. Remove:
 - Reed valve stop ①
 - Reed valve ②

INSPECTION

1. Inspect:
 - Rubber gasket
Deteriorated → Change
 - Reed valve
Ageing / cracks → Change

Inspection steps:

- Visually inspect the reed valve

NOTE

A proper reed valve should install in aligned or almost aligned with the neoprene base.

- In the event of any doubt about sealing apply suction to the part in the carburetor mounting
- Any leaks must be moderate

REED VALVE

CARB

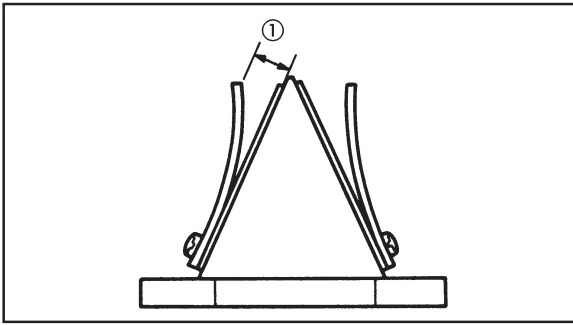

2. Measure:
 - Height of the valve stop ①Outside specifications → Adjust/ change the stop of the valve



Height of the valve stop:
6.28 mm

NOTE:

If the height is 0.4 mm greater or lower than what is specified, change the valve stop.

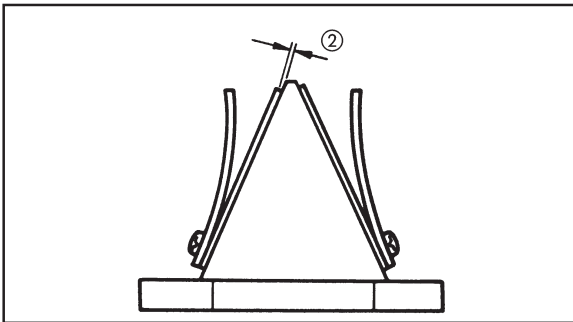

3. Measure:
 - Curve limit of the reed valve ②Outside specifications → Change



Curve limit of the reed valve:
0.4 ± 0.3 mm

ASSEMBLY

When the reed valve is fitted, apply the dismantling procedure inversely.

1. Install:
 - The reed valve
 - The reed valve stop.

NOTE:

Pay attention to the cut at the lower corner of the reed and the reed stop.

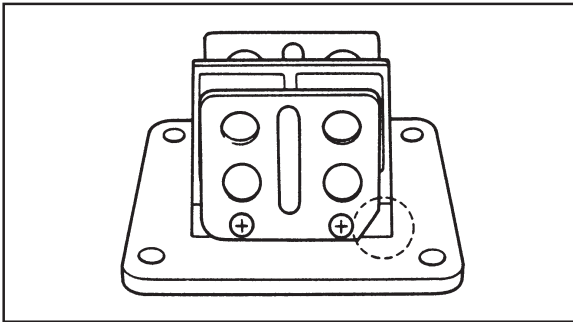

2. Tighten:
 - Safety screws of the reed valve



Safety screws of the reed valve:
0.1 m • kg
LOCTITE ®

NOTE:

Tighten each screw gradually to prevent deformations

**INSTALLATION**

To install the reed valve, follow the procedure for removal inversely. Pay attention to the following points.

1. Install:
 - A new gasket
2. Tighten:
 - Safety screws of the reed valve body.



Safety screws of the reed valve body:
0.8 m • kg

NOTE: _____

Tighten each screw gradually to prevent deformation

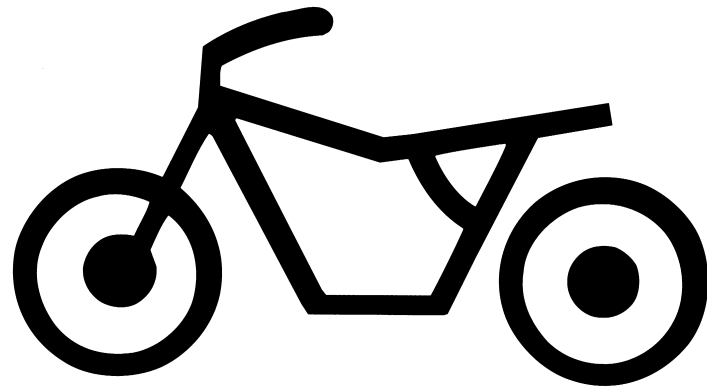

CHAS

7

CHAPTER 7 CHASSIS

FRONT WHEEL	7-1
DISMANTLING	7-2
INSPECTION.....	7-2
ASSEMBLY	7-5
REAR WHEEL	7-6
DISMANTLING	7-7
INSPECTION.....	7-7
ASSEMBLY	7-8
FRONT BRAKE	7-10
CHANGING THE BRAKE PADS	7-11
DISMANTLING THE CALIPER.....	7-13
DISMANTLING THE BRAKE PUMP	7-14
INSPECTING AND REPAIRING THE BRAKE	7-15
ASSEMBLY	7-17
FRONT FORK	7-20
REMOVAL	7-21
DISMANTLING	7-22
INSPECTION	7-22
ASSEMBLY	7-24
INSTALLATION	7-28
STEERING HEAD AND HANDLEBARS	7-29
DISMANTLING	7-31
INSPECTION	7-31
ASSEMBLY	7-34
REAR SHOCK ABSORBER AND SWINGING ARM	7-40
OBSERVATIONS ON HANDLING	7-41
OBSERVATIONS ON ELIMINATION	7-41
DISMANTLING	7-42
INSPECTION	7-44
ASSEMBLY	7-44
CHAIN AND TRANSMISSION CROWN WHEEL	7-46
DISMANTLING	7-47
INSPECTION	7-48
ASSEMBLY	7-49



CHASSIS

FRONT WHEEL

- ① Front wheel
- ② Spacer
- ③ Bearing
- ④ Bearing
- ⑤ Seal
- ⑥ Bush
- ⑦ Axle

AIR PRESSURE IN THE TIRES		
BASIC WEIGHT: WITH OIL AND FULL TANK	124.2 kg. (272 pounds)	
MAXIMUM LOAD *	195 kg. (428 pounds)	
COLD TIRE PRESSURE	FRONT	REAR
UP TO 90 KG (198 pounds) load *	1.8 kg/cm ²	2.0 kg/cm ²
FROM 90 kg (198 pounds) ~ MAX. LOAD	1.9 kg/cm ²	2.3 kg/cm ²

* Load means the total weight of equipment, driver and accessories

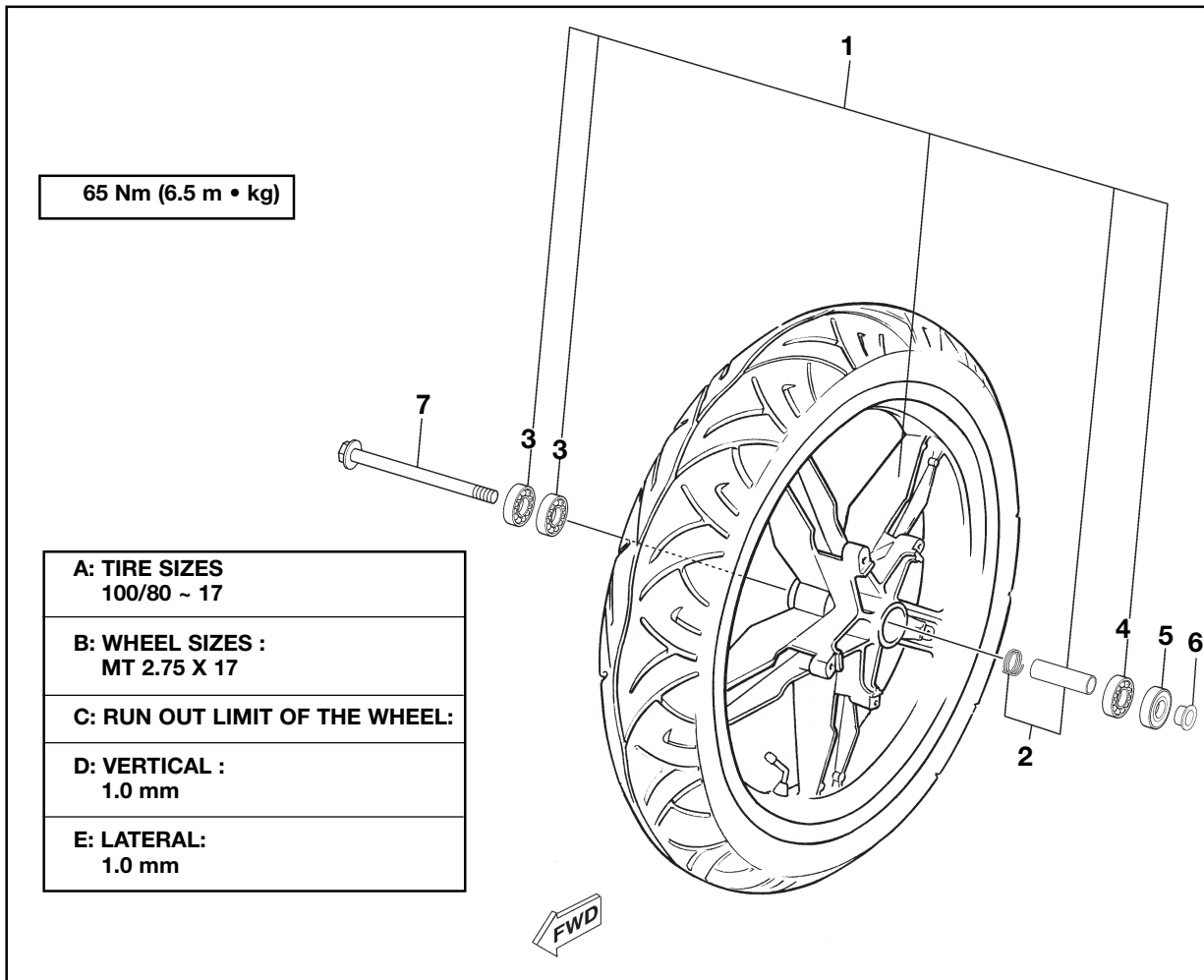



DISMANTLING

WARNING

Support the motorcycle firmly to avoid any risk of falling over.

1. Lift up the front wheel, placing an appropriate support under the engine.

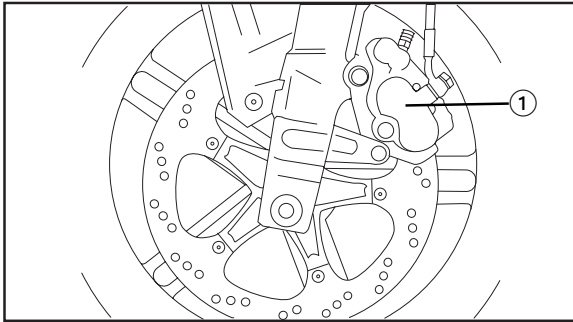

2. Remove :
 - The screws (brake caliper) ①

NOTE:

Do not press the brake lever without the wheel being fitted on the motorcycle since if you do the pads would be in contact.

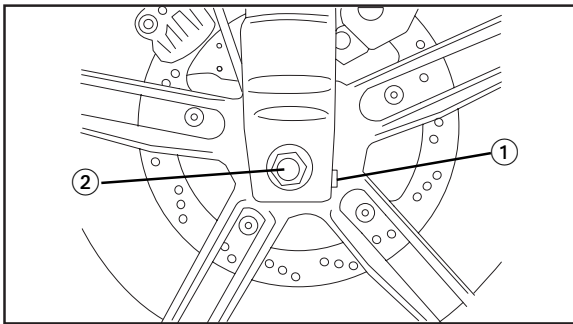

3. Loosen:
 - The pressure bolt ①
 - The screw (wheel axle) ②
4. Dismantle
 - The axle of the front wheel
 - The front wheel

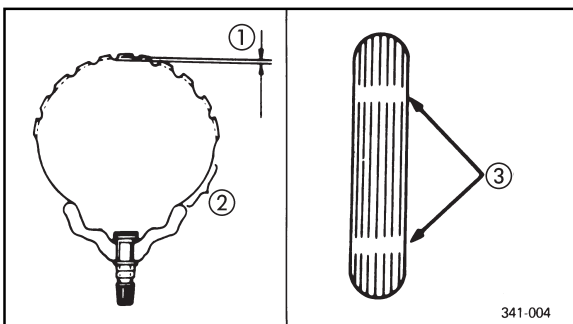
**INSPECTION**

1. Inspect
 - The tire
 - The running strip of the tire has transversal strips (minimum tread pattern depth) / Cracks → Replace



**Minimum depth of wear:
1.6 mm**

- ① Depth of tread pattern
- ② Lateral wall
- ③ Wear indicator

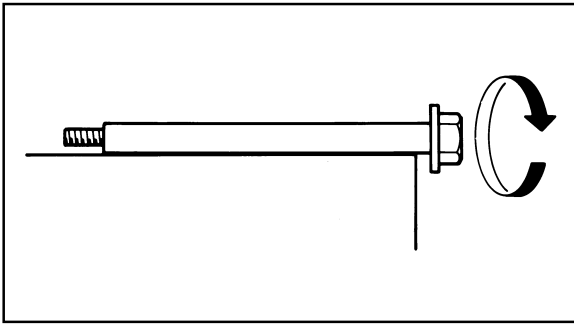

2. Get rid of any corrosion on the parts.
3. Inspect:
 - The front axle
 Make the axle turn on a flat surface
 Deformations → Replace

⚠ WARNING

Do not attempt to straighten the axle if this is deformed

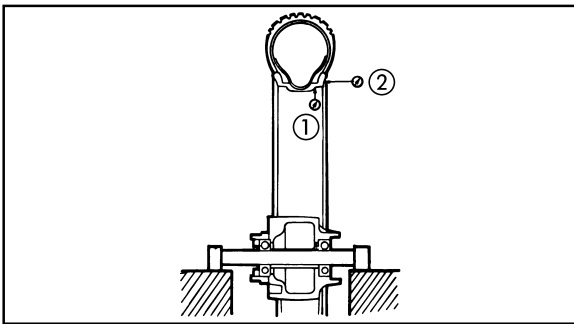

4. Inspect:
 - The wheel
 Cracks/Deformations/Warping → Replace

5. Measure:
 - The run out of the wheel
 This does not coincide with what is specified → Check the play of the wheel and bearing.

	Run out limit of the wheel:
	Radial ①: 2.0 mm
	Lateral ②: 2.0 mm

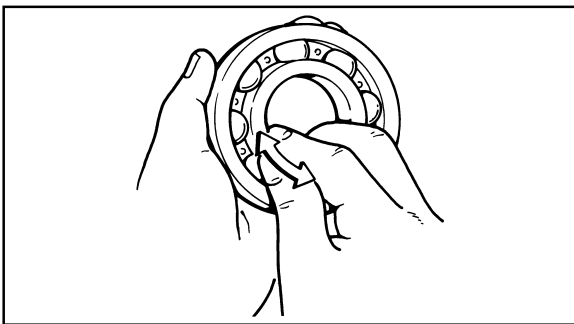

6. Check
 - The wheel bearings
 The bearings have some play at the wheel hub or are hard to turn → Replace

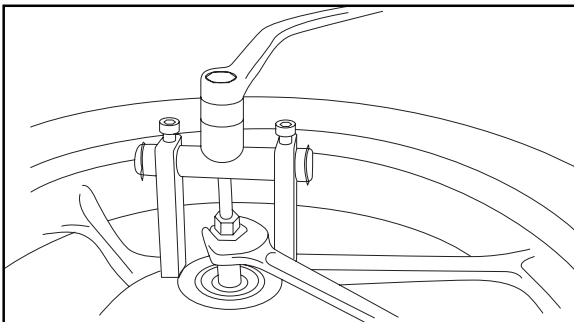

Replacing steps:
<ul style="list-style-type: none"> • Clean the outside of the wheel hub • Dismantle the bearing with a universal extractor • Install the new bearing
NOTE:
Use a socket wrench the right size for the outer diameter of the bearing race.

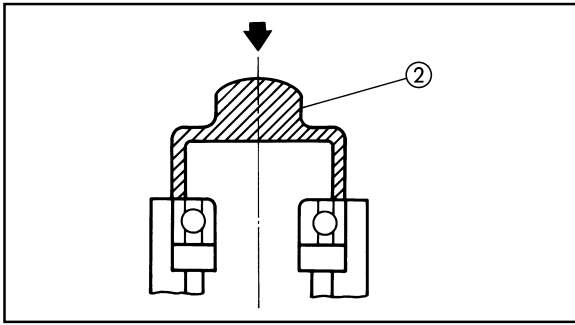

CAUTION _____

Do not tap the inner race of the bearing. Contact should only be with the outer race.

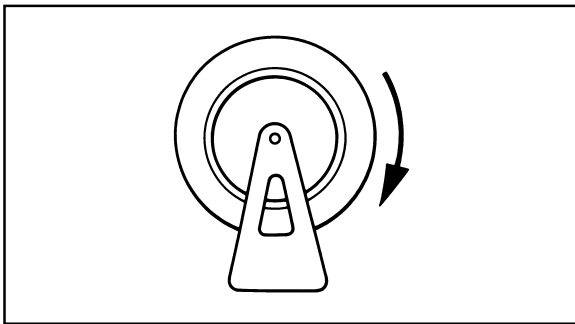

7. Check:
- The wheel balance
If the wheel stops at the same point again, after several light turns, the static balance is not correct. Wheel unbalanced. Install the relevant balancing counterweights at the lightest part (top).

NOTE: _____

Balance the wheel with the brake disc fitted.

⚠ WARNING _____

- After installing a tire, drive carefully until it adapts to the wheel properly. If this is not done there could be an accident possibly damaging the motorcycle and injuring the rider.
 - After repairing or replacing a tire, tighten the locknut ① of the valve to the specified torque
- _____

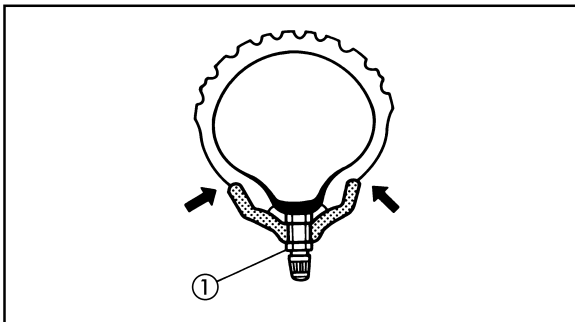

 **Valve locknut:**
0.15 kg • m

**INSTALLING**

Repeat the dismantling procedure, inversely.
Take into account the following points:

1. Apply:
 - Lithium grease
Lightly grease the oil seal and the gearing unit

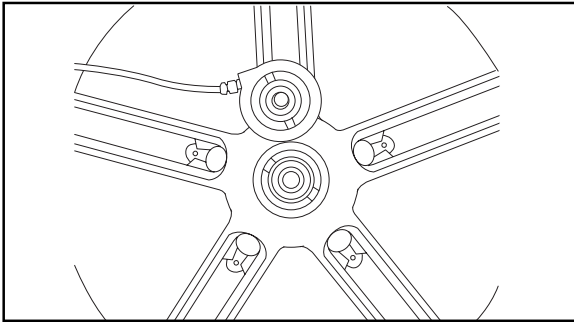

2. Assemble:
 - The speedometer sensor.

NOTE: _____

Make sure that the projections on the inside of the sensor coincide with the flat sides of the wheel hub.

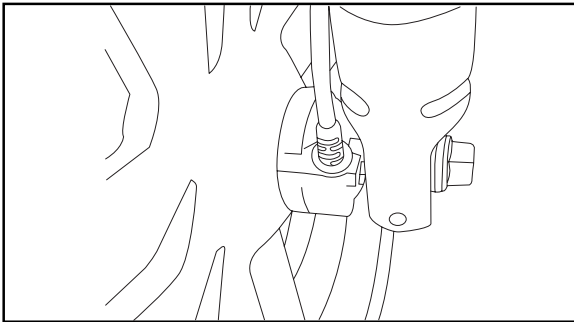

3. Assemble:
 - The front wheel assembly

NOTE: _____

Make sure that the projection of the fork cylinder fits in correctly with the sensor positioning slot.

4. Tighten:
 - The wheel axle
 - The pressure bolt
 - The screws (brake caliper)

**Wheel axle:**

6.5 m • kg

Pressure bolt:

2.3 km • kg

Screws (brake caliper):

3.5 m • kg



REAR WHEEL

- | | | |
|-----------------------|-------------------|--------|
| ① Rear wheel | ⑩ Chain | ⑲ Bush |
| ② Spacer | ⑪ Coupling | |
| ③ Bearing | ⑫ Wheel axle | |
| ④ Bearing | ⑬ Chain tensioner | |
| ⑤ Rear wheel sprocket | ⑭ Screw | |
| ⑥ Washer | ⑮ Nut | |
| ⑦ Screw | ⑯ Nut | |
| ⑧ Seal | ⑰ Key | |
| ⑨ Seal | ⑱ Bush | |

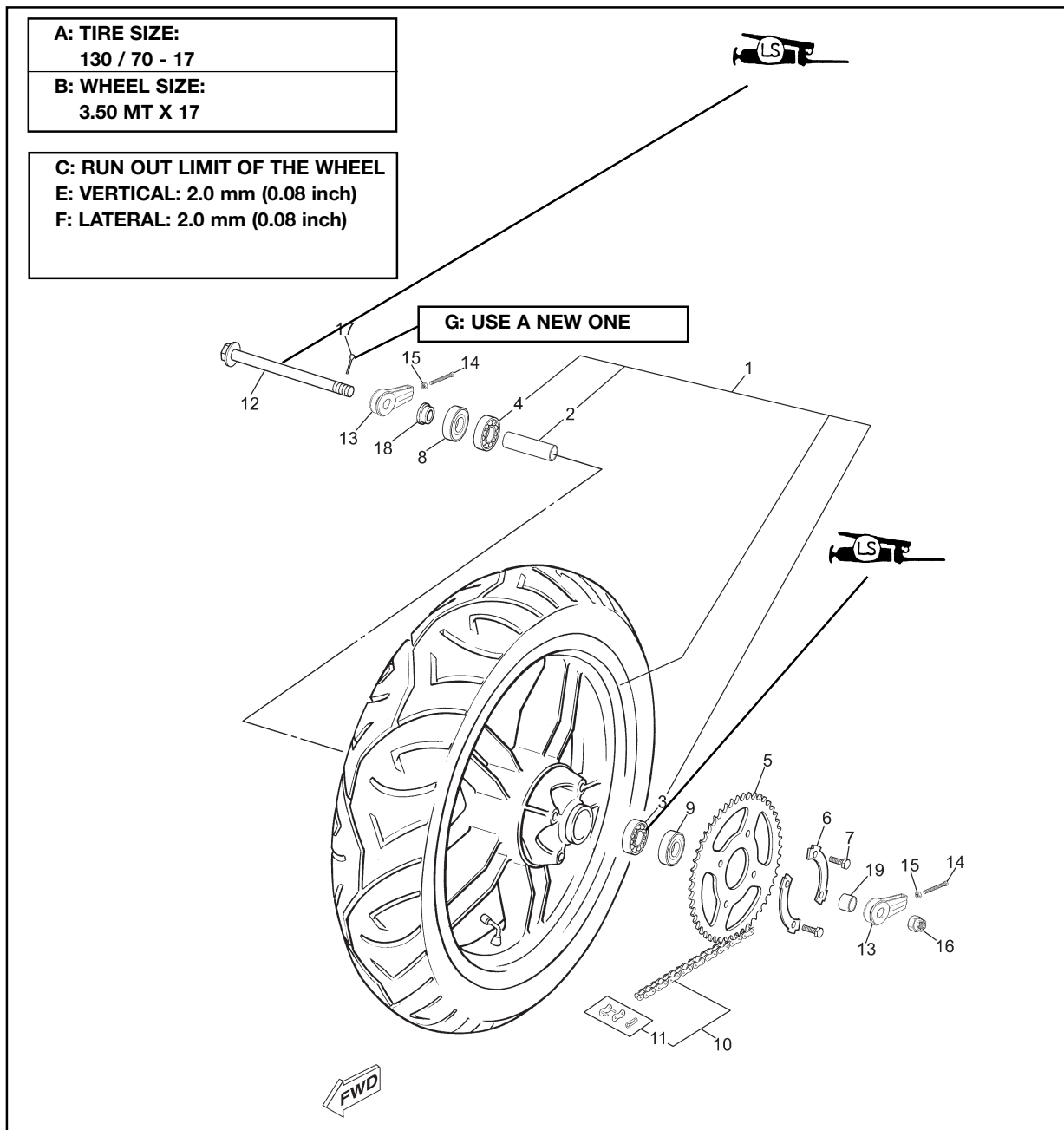



DISMANTLING

⚠ WARNING

Support the motorcycle firmly so it does not fall over

1. Lift the rear wheel and place a suitable support under the engine.

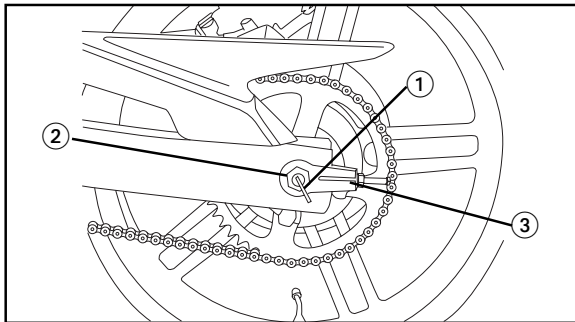

2. Dismantle:
 - The pin ①
 - The nut (wheel axle) ②
 - The chain tensioner ③
 - The wheel axle

3. Dismantle:
 - The rear wheel

NOTE: _____

Before removing the rear wheel, push this forwards and dismantle the transmission chain.

NOTE: _____

Do not press the brake lever without the wheel being fitted as this would mean the pads would be in contact

INSPECTION

1. Inspect:
 - The tire
 - The rear wheel axle
 - The wheel

See the section on "FRONT WHEEL - INSPECTION"



2. Measure:
 - The run out of the wheel
See the section on "FRONT WHEEL - INSPECTION"
3. Check:
 - The wheel bearings
 - The wheel balancing
See the section on "FRONT WHEEL - INSPECTION"
 - The brake disc
See the section "FRONT WHEEL - INSPECTION"

ASSEMBLY

Apply the same procedure as for dismantling but inversely.

Take into account the following points:

1. Apply:
 - Lithium grease
Apply the grease lightly to the lips of the oil seal
2. Adjust:
 - The transmission chain tension with the rear wheel resting on the ground



Transmission chain tension:
20 ~ 25 mm

See the section on "TIGHTENING THE TRANSMISSION CHAIN" in CHAPTER 3.

3. Tighten:
 - The axle nut
 - The locknut (wheel axle)



Nut (wheel axle)
9.0 m • kg
Screws (brake caliper):
3.0 m • kg

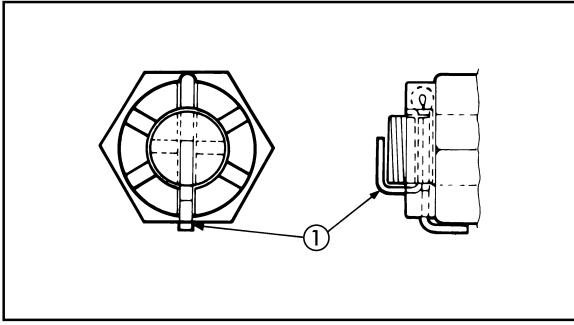

4. Install:
 - The pin (a new one) ①

⚠ WARNING

Always use a new pin for the wheel axle.

5. Adjust:
 - The free play of the brake pedal
See the section on “ADJUSTING THE REAR BRAKE” in CHAPTER 3.



**Free play of the brake pedal:
10 ~ 15 mm**



FRONT BRAKE

- ① Disc brake
- ② Screw
- ③ Complete brake caliper
- ④ Complete pistons
- ⑤ Brake pads
- ⑥ Drain screw
- ⑦ Pin
- ⑧ Through screw
- ⑨ Seal
- ⑩ Screw

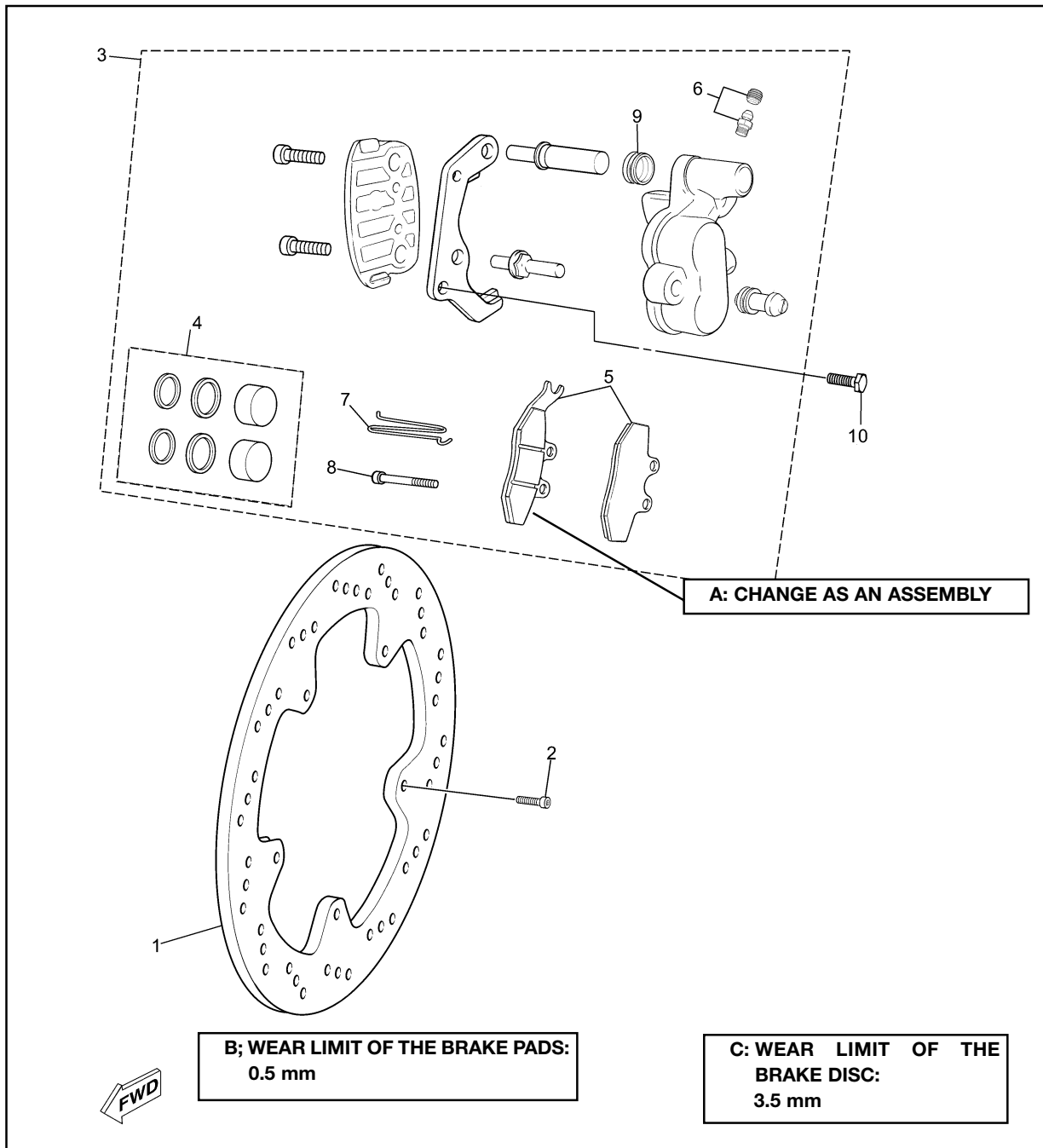

**CAUTION**

The components of the disk brake rarely need to be dismantled. Do not do so unless this is absolutely necessary. If any of the hydraulic coupling components of the system is disconnected the whole system must be dismantled to drain this, clean it and then fill it and bleed it properly. Do not use solvents to clean the components.

Solvents make seals swell and deform. Only use clean brake liquid for cleaning. Take care with brake liquid, as this is harmful for the eyes and damages painted surfaces and plastic parts.

CHANGING THE BRAKE PADS**NOTE:**

To change the brake pads the line does not need to be taken off.

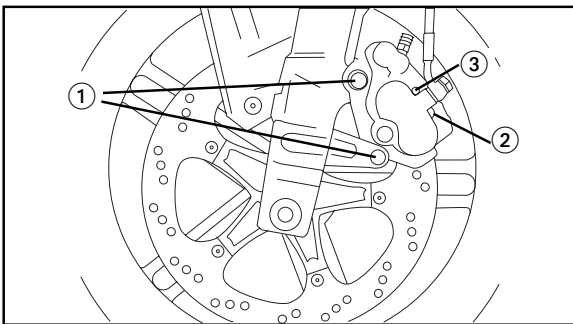

1. Dismantle:
 - The screws (brake caliper) ①
 - The retaining screw ②
 - The retaining pin ③
 - The pads

FRONT BRAKE

CHAS

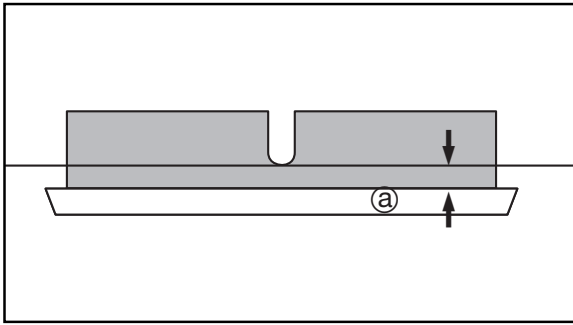

2. Measure:
 - The thickness (a) of the pads:
If this does not match the value specified
→ replace

NOTE:

- Replace the pads as a set, if you find that any of them is worn beyond the limit.



Wear limit:
0.5 mm

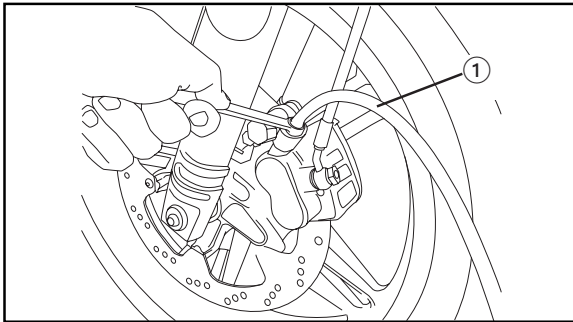

3. Firmly connect a suitable tube 1 to the caliper bleeding screw. Then insert the other end of the tube into an open recipient.
4. Unscrew the bleed screw of the caliper and press the piston with your finger to make it go into this.

5. Tighten:
 - The caliper bleeding screw



Caliper bleeding screw:
0.5 m • kg

6. Assembly:
 - The brake pads (new)
 - The retaining screw
 - The retaining pin

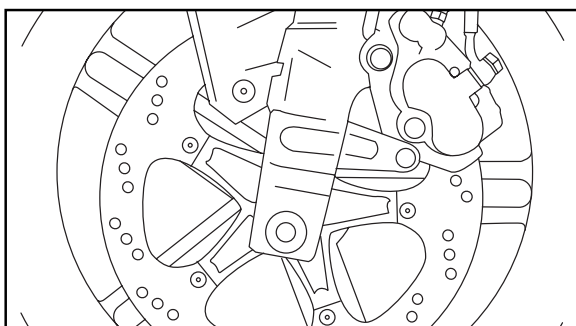

7. Install:
- The screws (brake caliper)



Screws (brake caliper):
3.5 kg • m

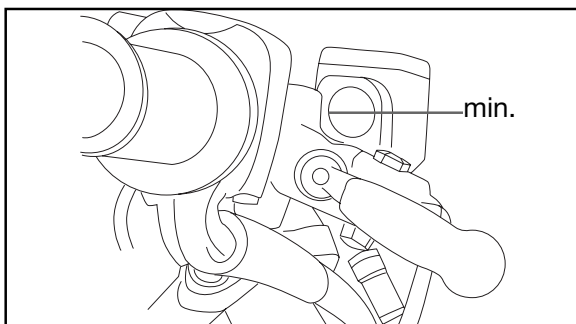

8. Inspect:
- The level of the brake liquid
See the section on "INSPECTING THE BRAKE LIQUID" in CHAPTER 3.

9. Check:
- The operation of the brake lever. If this is soft or spongy → bleed the brake system.
See the section on "BLEEDING THE AIR" in CHAPTER 3.

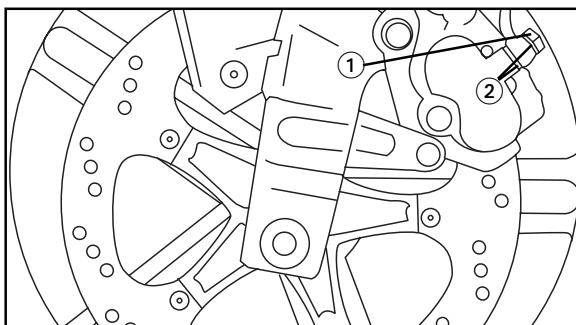

DISMANTLING THE CALIPER

1. Remove:
- The coupling screw ①
 - The copper washers ②

NOTE:

Place the open end of the line in a recipient and carefully pump to remove the old liquid.



2. Dismantle:
 - The screws (brake caliper)
 - The brake pads
 - See the section on "CHANGING THE BRAKE PADS"

3. Dismantle:
 - Pistons

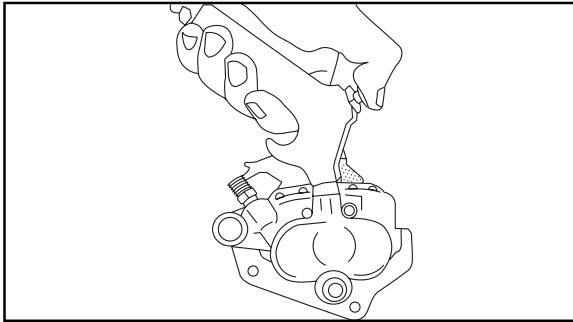
**Dismantling steps:**

- Use a cloth to block the piston on the right-hand side.
- Blow compressed air in through the coupling hole of the line to force the piston on the left-hand side out of the caliper.
- Insert the piston a few mm and lock it with a cloth to prevent it from getting out.
- Repeat the previous steps with the piston for the right-hand side, to force it out of the caliper.

⚠ WARNING

- **Never attempt to take the piston out of the caliper by levering this with a tool.**
- **Cover the piston with a cloth**
- **Take care to avoid injuries by the piston being ejected out of the cylinder.**

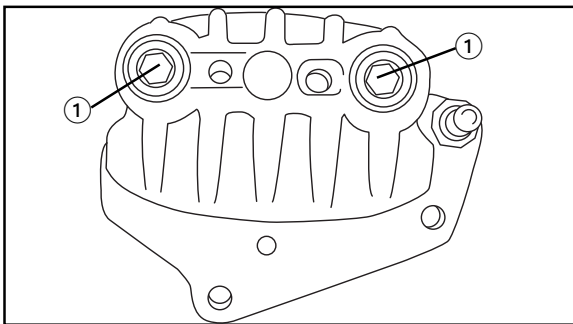

4. Remove:
 - The screws ①
 - The pistons
 - The seals

DISMANTLING THE BRAKE PUMP**NOTE:**

Remove the brake liquid before dismantling the brake pump.

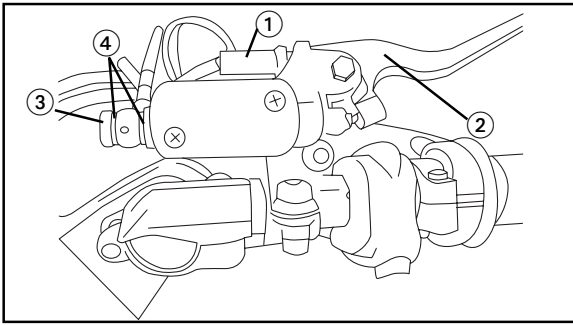

1. Dismantle:
 - The brake switch ①
 - The brake lever ②
 - The coupling screw ③
 - The copper washers ④

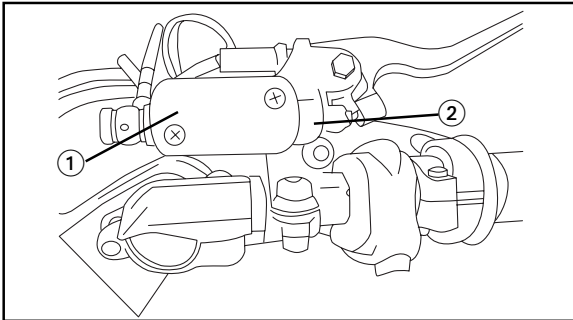

2. Dismantle:
 - The pump cover ①
 - The rubber seal
 - The pump ②

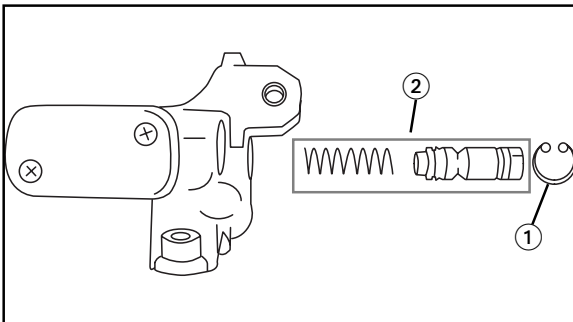

3. Dismantle:
 - The circlip ①
 - The set of pump components ②

INSPECTION AND REPAIR

Recommended schedule for replacing the brake components:	
Pads	As required
Piston seals and dustcover	Every two years
Lines	Every four years
Brake lines	Change only when the brake is dismantled

⚠ WARNING

The internal items should be cleaned only with unused brake liquid. Do not use solvents because these would make the seals expand and deform

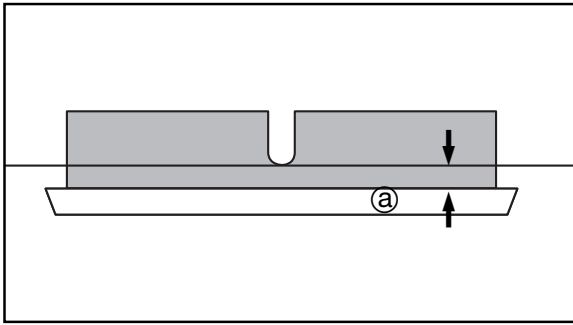

1. Measure:
 - The brake pads (thickness) (a)
 - Out of specification → replace

NOTE: _____

- Change the pads as a set, whenever any of these is worn down beyond the limit.



Wear limit:
0.5 mm

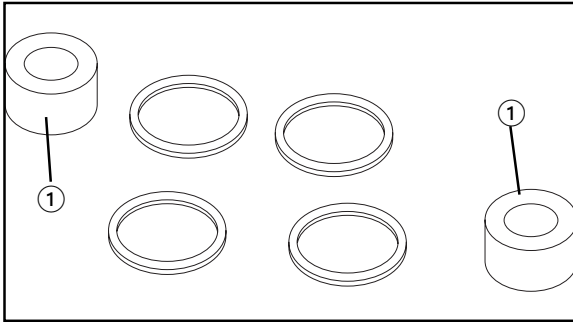

2. Inspect:
 - The pistons of the caliper ①
 - Rusting / Wear / Damage → Replace

⚠ WARNING _____

Change the piston seals whenever the caliper is dismantled.

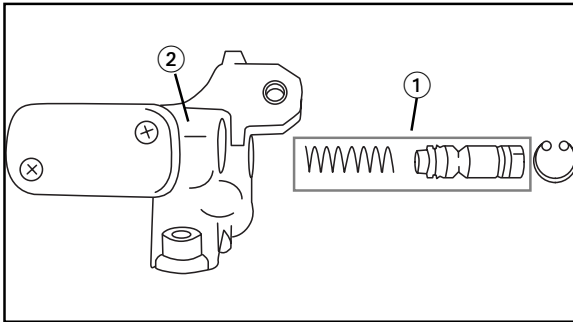

3. Inspect:
 - Set of pump components ①
 - Pump body ②
 - Scratching / Wear → Replace
 - Brake line
 - Cracks / Wear / Damage → Replace



Maximum deviation /A/:
0.15 mm
Minimum disc thickness /B/:
3.5 mm

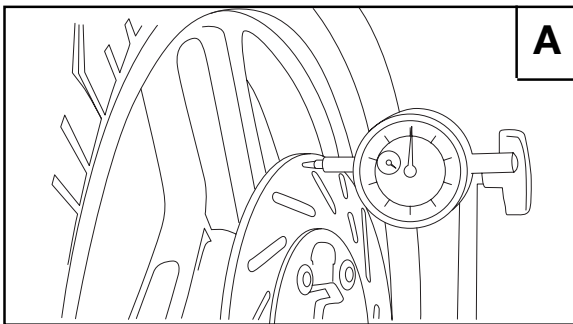

4. Inspect:
 - The brake disc
 - If this does not match the value specified → Replace

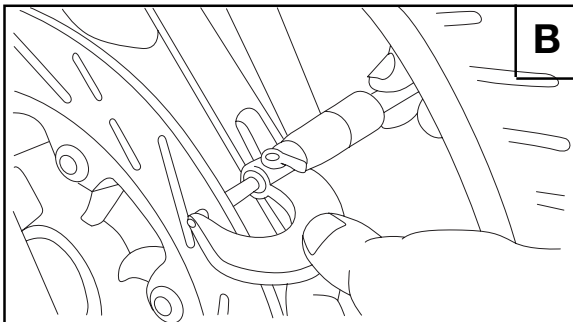



ASSEMBLY

⚠ WARNING

- All the internal components must be cleaned only with new brake liquid.
- The internal items must be lubricated with brake liquid when assembled.



Brake liquid:
DOT n° 4

- Change the piston seals whenever the caliper is dismantled.

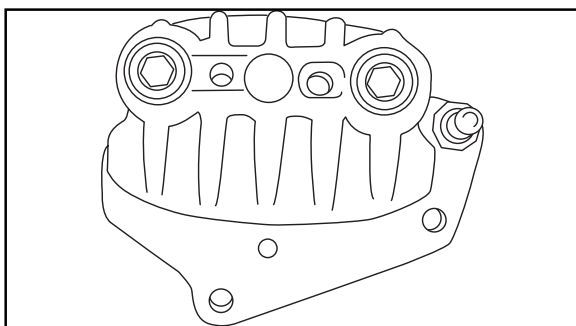

1. Assemble:
 - The seals
 - The pistons
 - The screws

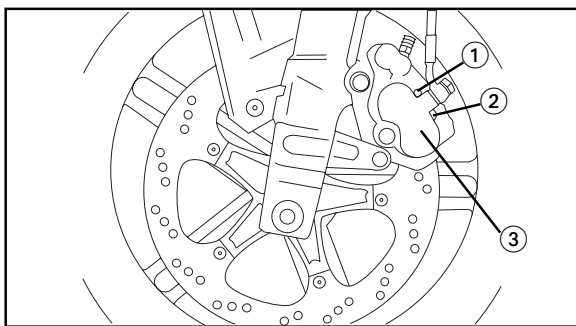

2. Assemble:
 - The retaining pin ①
 - The retaining screw ②
 - The brake caliper ③

See the section on “CHANGING THE BRAKE PADS”



Screw (brake caliper):
3.5 kg • m

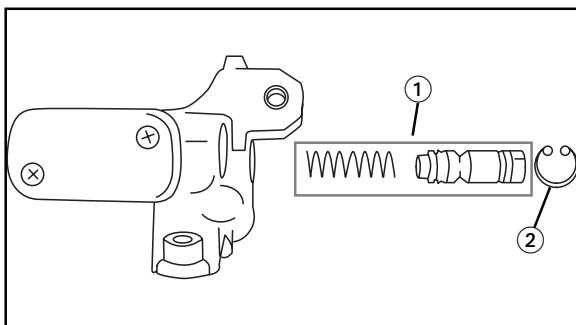

3. Assemble:
 - The set of pump components ①
 - The circlip ②



4. Assemble:
 - The dust seal ①
 - The brake pump ②

	Screws (pump support) : 0.9 kg • m
--	--

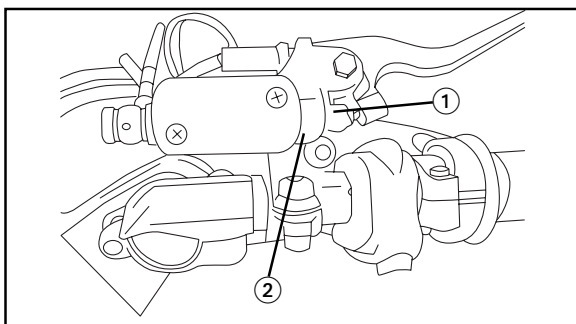

5. Assemble:
 - The line ①
 - The copper washers ②
 - The coupling screw ③

	Coupling screws: 2.6 kg • m
--	---------------------------------------

⚠ WARNING _____
Always use new copper washers

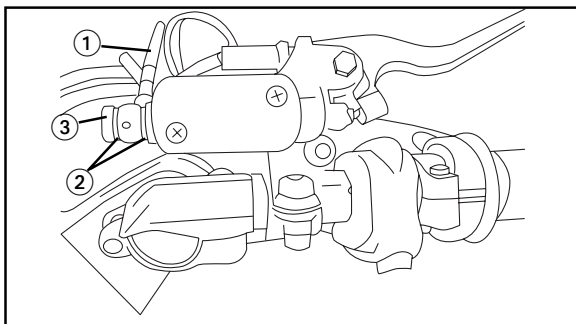

6. Assemble:
 - The brake switch ①
 - The brake lever ②

NOTE: _____
 Apply lithium soap grease to the brake lever rotation spindle

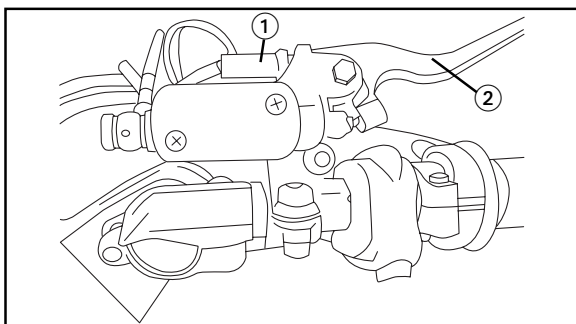



7. Fill up:
- Brake liquid



Recommended brake liquid:
DOT n° 4

CAUTION

The brake liquid could erode painted surfaces and plastic parts. Always clean any liquid spilt.

WARNING

- Use only brake liquid of the specified quality: otherwise the rubber seals could deteriorate and give rise to leaks and reduction of the braking efficiency.
- Always fill up with brake liquid of the same type: mixing liquids could give rise to harmful chemical reactions and reduce efficiency.
- Take care that water does not get into the master cylinder when filling up. Water considerably reduces the boiling temperature of the liquid and could give rise to obstruction through bubbles.

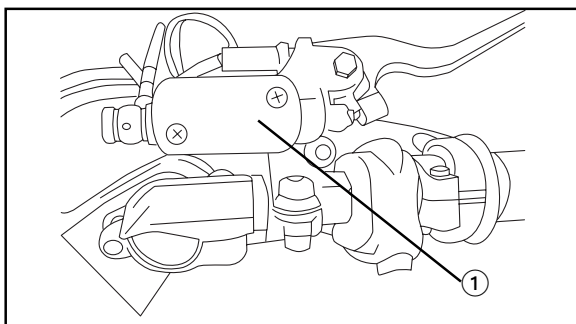

8. Assemble:
- The rubber seal
 - The pump cover ①



Screw (pump cover):
0.2 kg • m

9. Bleed:
- The air
- See the section on “BLEEDING THE AIR” in CHAPTER 3.

FRONT FORK

- ① Rubber plug
- ② Circlip
- ③ Plug screw
- ④ O ring
- ⑤ Fork spring
- ⑥ Ring of the damper rod
- ⑦ Damper rod (full cylinder)
- ⑧ Rebound spring
- ⑨ Inner tube
- ⑩ Tapered spindle
- ⑪ Dust sealing plug
- ⑫ Retaining clip
- ⑬ Oil seal
- ⑭ Guide bush
- ⑮ Outer pipe
- ⑯ Draining screw
- ⑰ Screw (Damper rod)
- ⑱ Steering axle

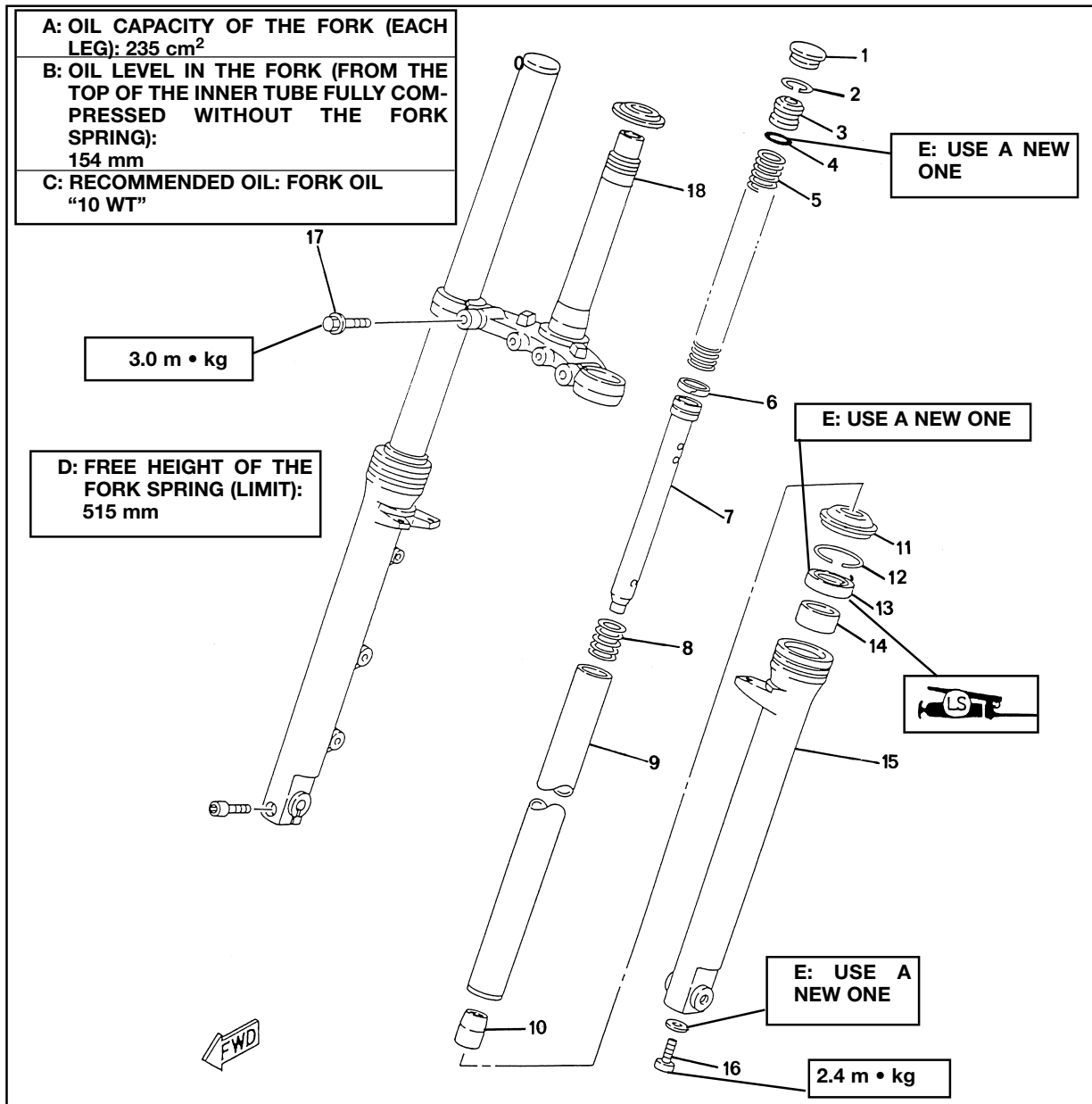

REMOVAL

⚠ WARNING

Stand the motorcycle up firmly so that there is no risk of it falling over.

1. Lift up the front wheel placing an appropriate support under the engine.
2. Dismantle:
 - The front wheel
See the section on "DISMANTLING THE FRONT WHEEL"
3. Dismantle:
 - The front mudguard

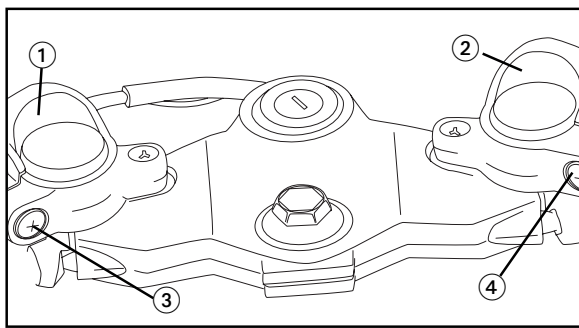
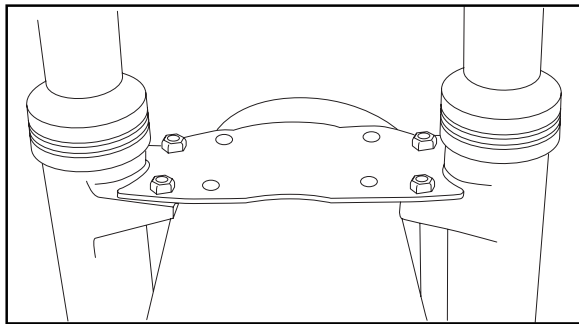

4. Dismantle:
 - The lever (left-hand) ①
 - The lever (right-hand) ②
5. Loosen:
 - The clamp screw (left-hand) ③
 - The clamp screw (right-hand) ④

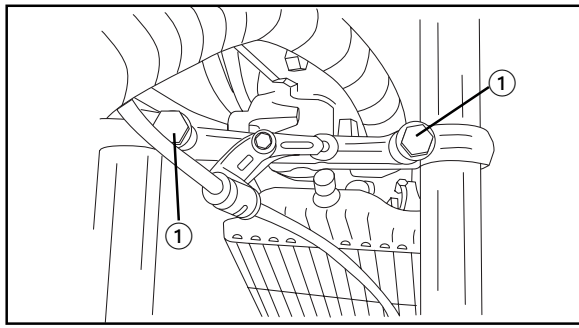

6. Loosen:
 - The clamp screw ① (lower shank)

⚠ WARNING

Hold the fork before loosening the clamp screw

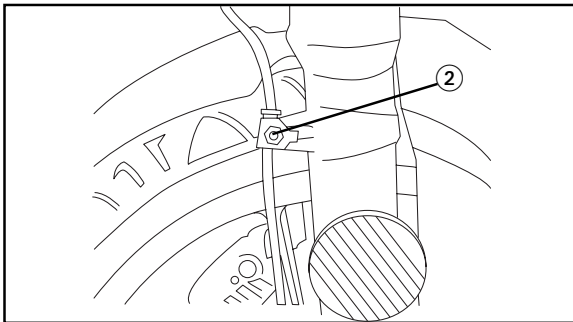
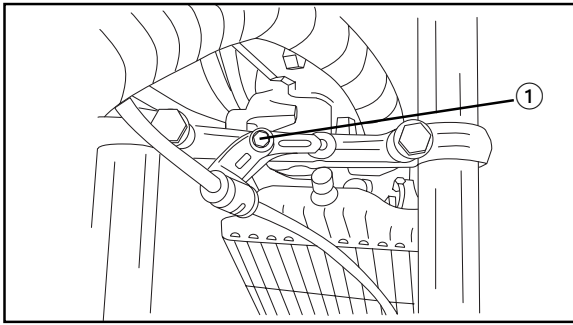

NOTE:

When the fork legs are dismantled, also remove the screws ① (brake line clamp) and ② odometer cable.

7. Dismantle:
 - The front fork

DISMANTLING

1. Remove:
 - The rubber plug
 - The clip
 - The plug
 - The fork spring

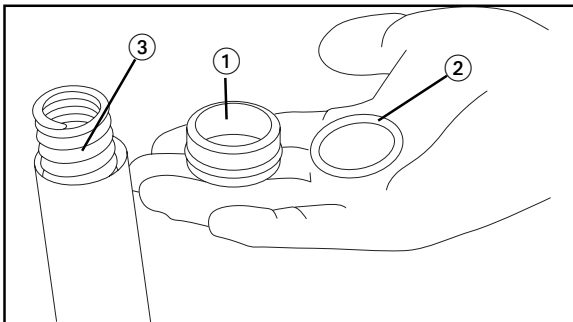
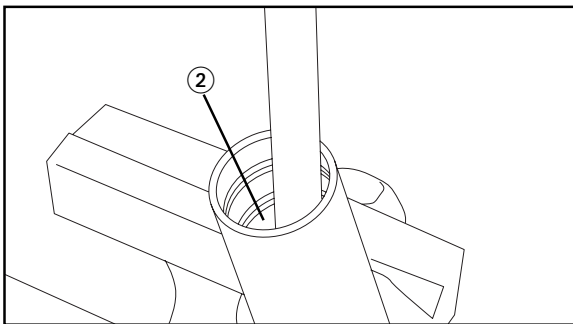

Dismantling steps:

- Hold the fork leg in a vertical position
- Hold the inner tube in a vice with soft clamps

CAUTION

Do not damage the surface of the internal tube.

- Apply pressure to the plug ① with a suitable bar
- Keep the plug ① in position and remove the clip ② with a fine screwdriver.
- Remove the plug ① and the fork spring ③.
- Install a tray for the oil under the fork, place this upside down and drain out the oil.

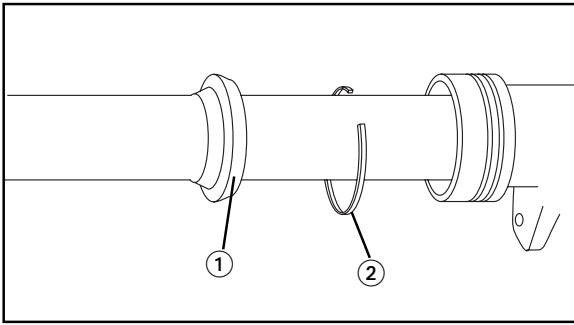

2. Drain:
 - The oil out of the fork
3. Remove:
 - The dust sealing cover ①
 - The retainer clip ②
 Use a fine screwdriver and take care not to scratch the inner tube.

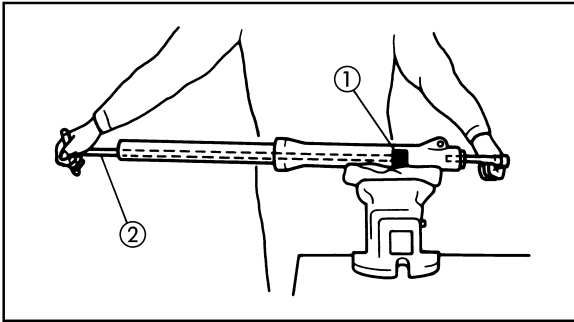

4. Remove:
 - The screw (damper rod)
 Use the fixing tool ① and the "T" tool ② to lock the damper rod.



"T" tool
 90890 - 01326
Fixing tool:
 90890 - 01294

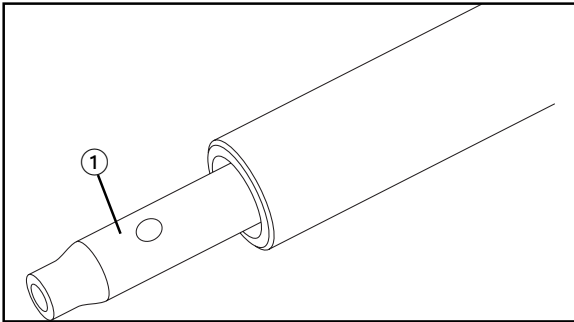

5. Dismantle:
 - The inner tube
 - The damper rod ①

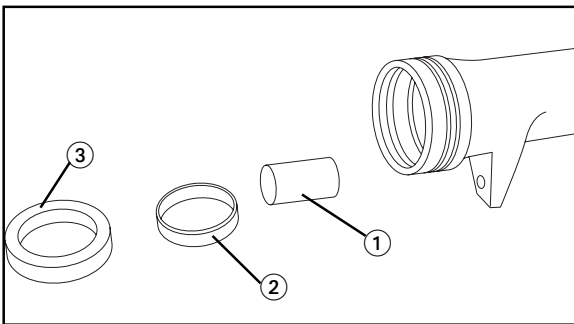

6. Dismantle:
 - The conical spindle ①
 - Guide bush ②
 - Oil seal ③

CAUTION

When dismantling the oil seal and the guide bush, do not scratch the wall of the outer tube.

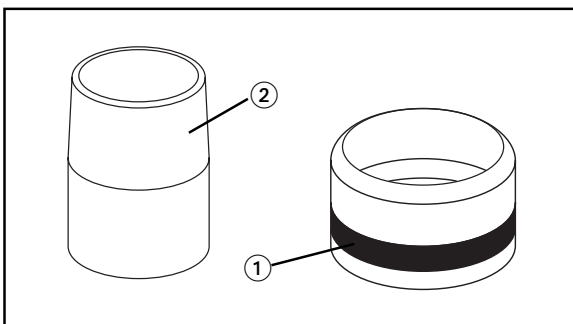
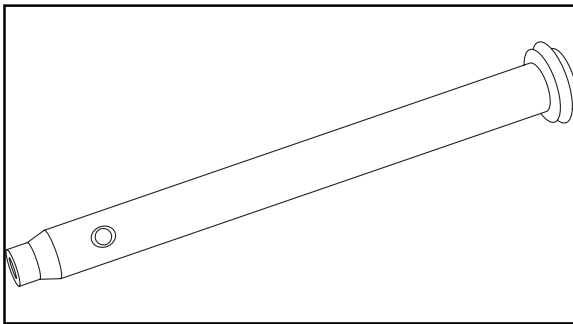
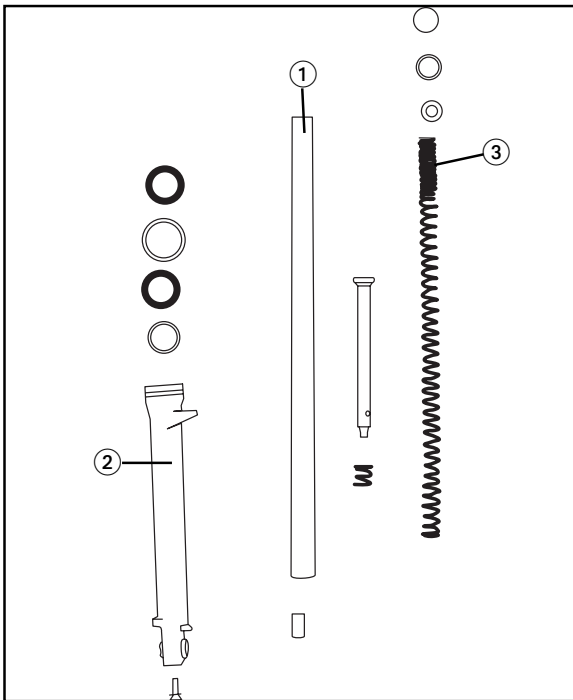

INSPECTION

1. Inspect:
 - The inner tube ①
Scratching / Deformations → Replace

⚠ WARNING

Do not try to straighten the inner tube if this is bent, as it could be dangerously weakened.

- Outer tube ②
Scratching / Deformations / Damage → Replace
- Fork spring ③
If this exceeds the limit specified → Replace



**Free height of the fork spring:
(limit): 508 mm**

2. Inspect:
 - The damper rod
Wear / Damage → Replace
 - Dirt → Blow all the items with compressed air

3. Inspect:
 - The O ring (of the plug) ①
 - The tapered spindle ②
Damage → Replace

ASSEMBLY

Apply the same procedure as for “DISMANTLING” but inversely.
Take into account the following points.



NOTE:

- When putting the fork back on, make sure that you replace the following items with new ones.
- Guide bush
- Oil seal
- Dust protection seal
- Make sure that all the components are clean before installing these again.

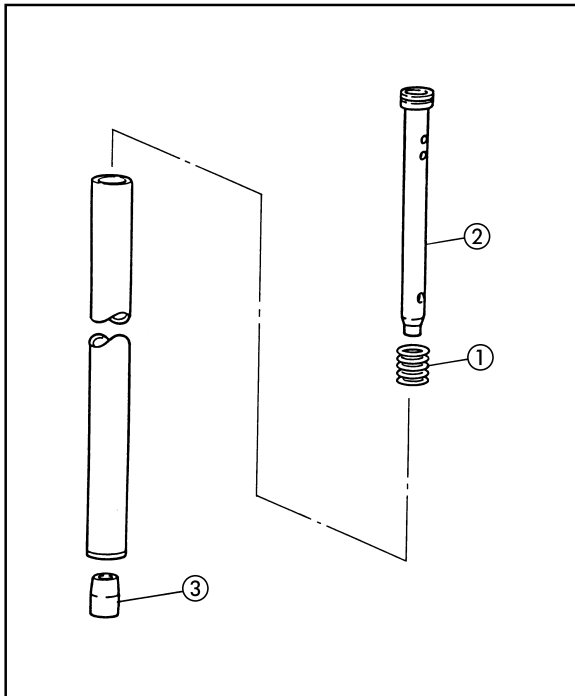

1. Install:
 - The fork spring ①
 - The damper rod ②
Let the rod slide slowly along the tube until it comes out of the bottom.
 - Tapered spindle ③
Install the tapered spindle over the damper rod coming out at the end of the inner tube.

2. Install:
 - The inner tube in the cylinder (outer tube)

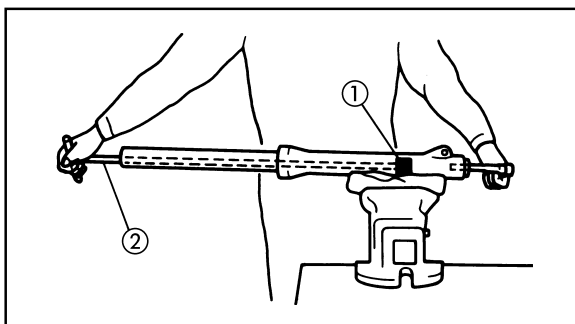

3. Tighten:
 - The screw (damping pipe)
Use the fixing tool ① and the "T" tool ② to lock the damper rod.

	<p>"T" tool : 90890 - 01326</p> <p>Fixing tool: 90890 - 01294</p>
--	---

	<p>Screw (damper rod): 2.4 kg • m LOCTITE®</p>
--	---

FRONT FORK

CHAS

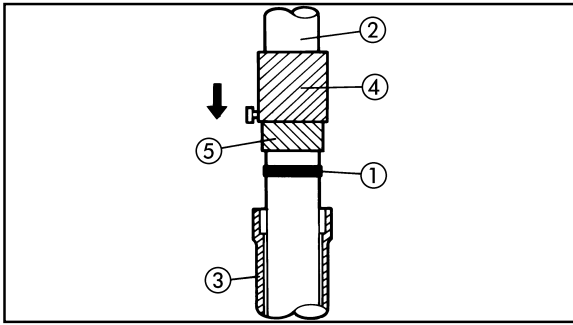

4. Install:
- The guide sleeve ①
Use the counterweight for installing fork 4 seals and the adapter 5.

- ② Inner tube
- ③ Outer tube



Counterweight for installing the fork seals:
90890 - 01367
Adapter:
90890 - 01400

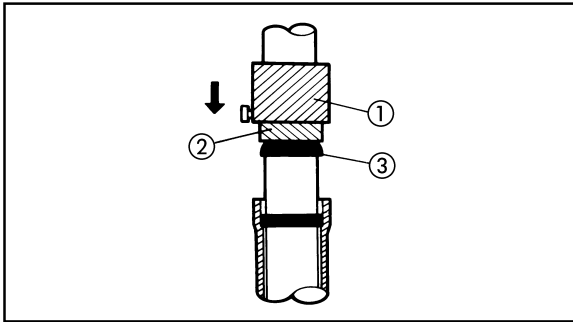

5. Install:
- The oil seal ③ (new)
Use the counterweight for installing the fork ① seals and the adapter ②.



Counterweight for installing the fork seals:
90890 - 01367
Adapter:
90890 - 01400

6. Fill up:
- the fork



Capacity of fork oil:
235 cm²
Type:
10W or equivalent fork oil

NOTE: _____

After filling the fork up with oil, pump this slowly up and down to distribute this.

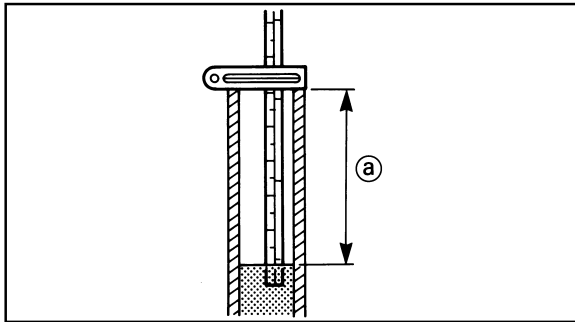

7. Measure:
- The oil level (a)
If this does not coincide with the value specified → add or remove oil.



Oil level:
154 mm
Measurements from the top of the inner tube.

- NOTE:** _____
- To measure the oil level, thoroughly check the inner tube, without the fork spring.
 - Install the fork in vertical position.

8. Install:
- The fork spring
 - The stop ring

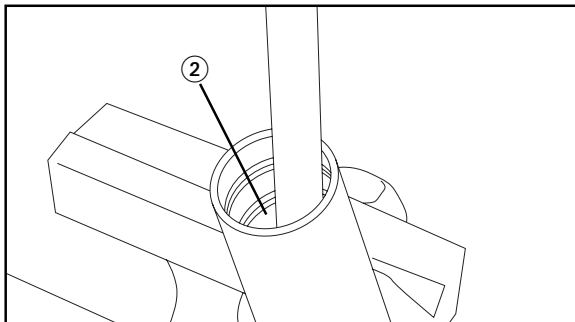
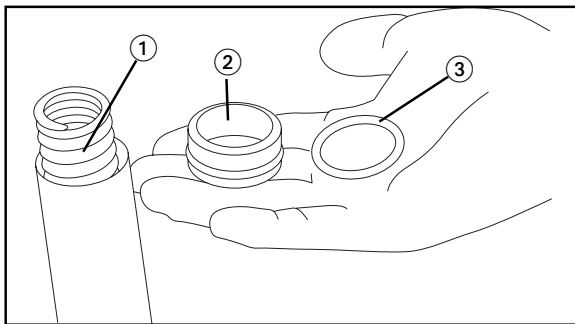

Installation steps:

- Hold the fork leg up vertically
- Set the inner pipe in a vice with soft clamps

CAUTION _____

Avoid damaging the surface of the inner tube.

- Install the fork spring 1 in the inner tube.

NOTE: _____

Install the fork spring with the side with narrower aperture upwards.

- Inspect the O ring (of the plug). If this is damaged, replace this.
- Install the plug ② onto the spring; press the plug with a suitable bar.
- Install the plug and place the elastic ring ③ in the inner tube.



INSTALLING

Use the "EXTRACTION" procedure inversely. Take into account the following points.

1. Install:
 - The fork
Provisionally tighten the clamp screws of the handlebars.

NOTE:

Maintain the inner tube.

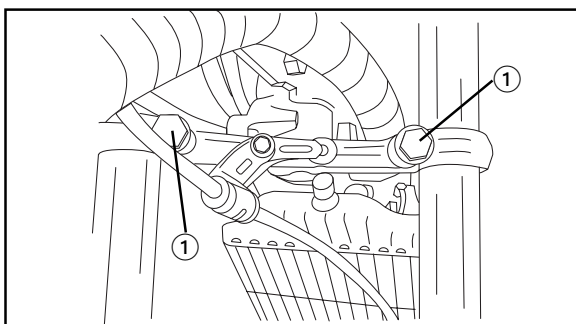
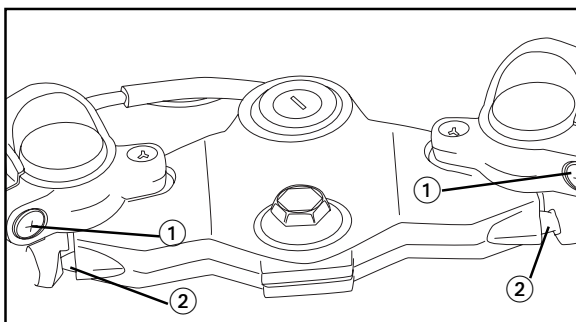

2. Tighten:
 - The (handlebar) clamp screws ①
 - The clamp screws (upper shank of the handlebar) ②

	(Handlebar) clamp screws: 2.0 kg • m Clamp screws (upper shank of the handlebar): 2.0 kg • m
--	---

3. Tighten:
 - The clamp screw (lower shank) ①

	Clamp screw (lower shank): 3.0 kg • m
--	--

4. Install:
 - The front mudguard

	Screws (front mudguard): 0.8 kg • m
--	--

5. Install:
 - The front wheel
See the section on "FRONT WHEEL - FITTING"

	Wheel axle: 7.4 kg • m Screws (brake caliper): 3.5 kg • m
--	--

STEERING HEAD AND HANDLEBARS
HANDLEBARS

- ① Handlebar (left-hand)
- ② Handlebar (right-hand)
- ⑥ Handlebar counterweight
- ⑦ Guide tube of the acceleration cable
- ⑧ Rubber twist grip
- ⑨ Set of throttle cable and mixing pump
- ⑩ Clutch cable
- ⑬ Tensor
- ⑭ Locknut

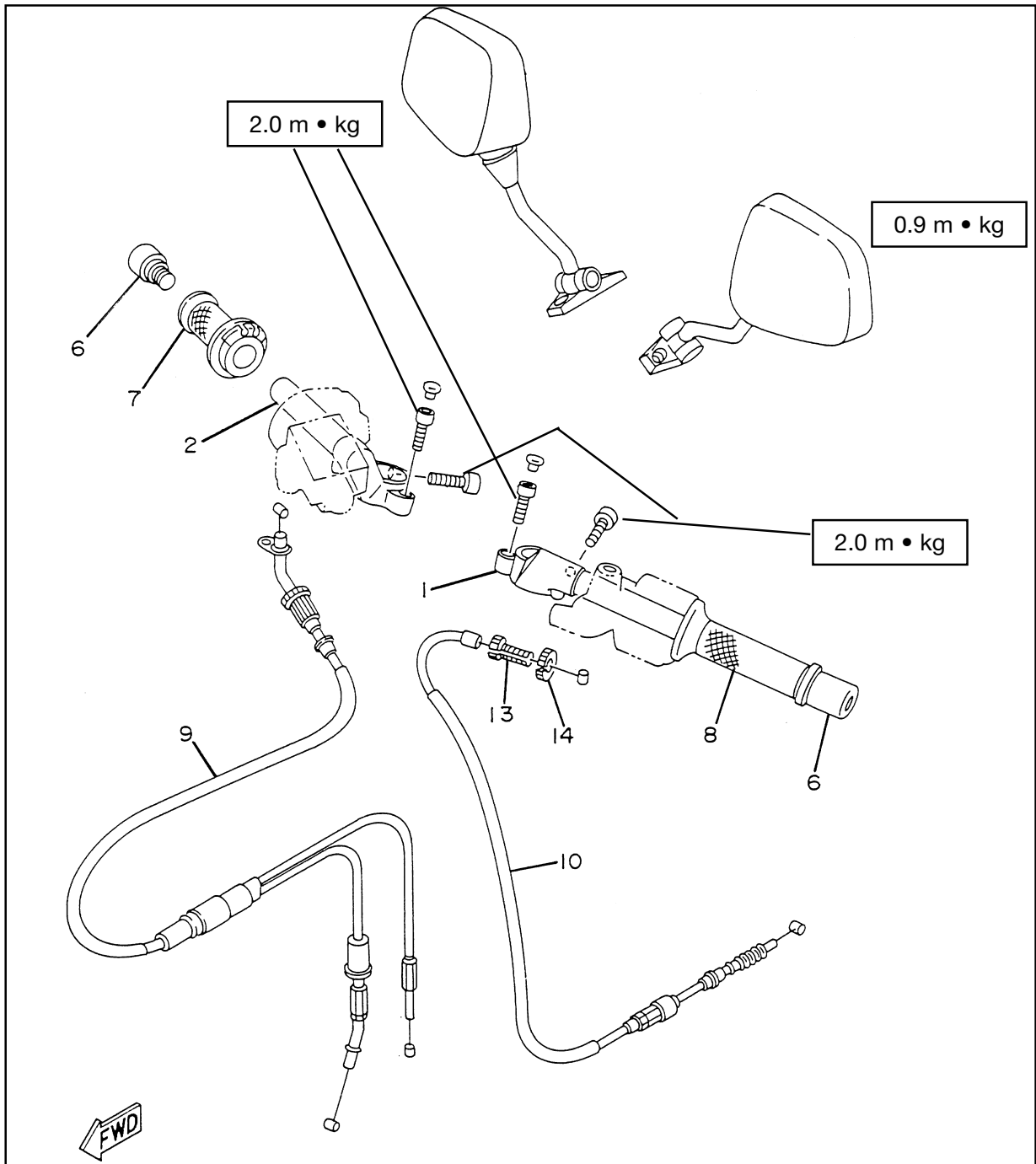



STEERING HEAD

- ② Upper race of the bearing
- ③ Lower race of the bearing
- ④ Ball bearing
- ⑤ Cover of the ball bearing race
- ⑥ Steering adjustment nut
- ⑦ Upper shank of the handlebar
- ⑧ Steering nut

A: BEARING DIMENSIONS:
 1/4 inch
NUMBER OF BALLS:
 LOWER: 19 units
 UPPER: 19 units

B: TIGHTENING STAGES:

- Tighten the annular nut:
2.0 kg • m
- Unscrew one turn
- Tighten this again:
1.0 kg • m

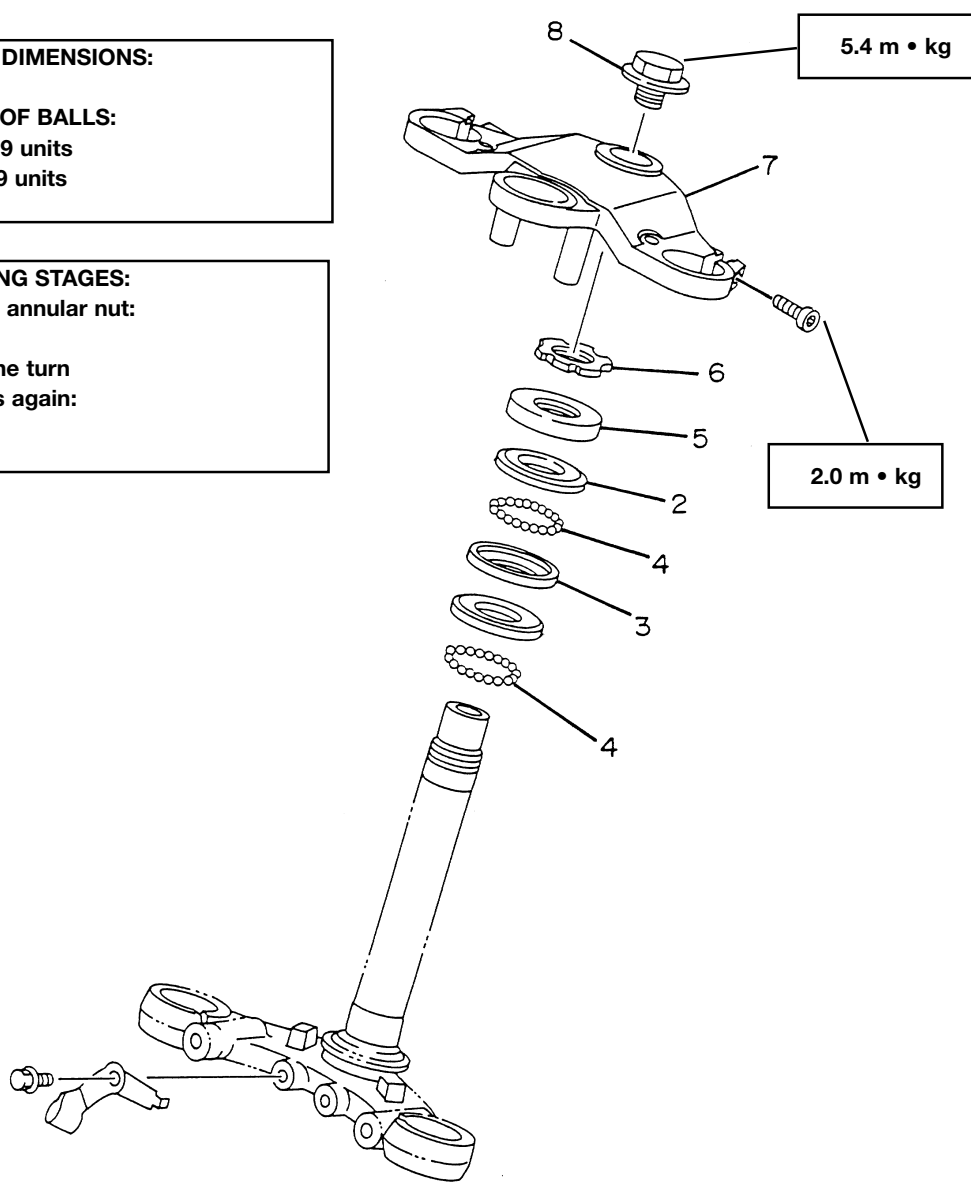



DISMANTLING

⚠ WARNING

Stand the motorcycle up firmly to prevent it from falling over

1. Lift the front wheel up installing an appropriate support under the engine.
2. Dismantle:
 - The front wheel
 - See the section on "FRONT WHEEL - DISMANTLING"

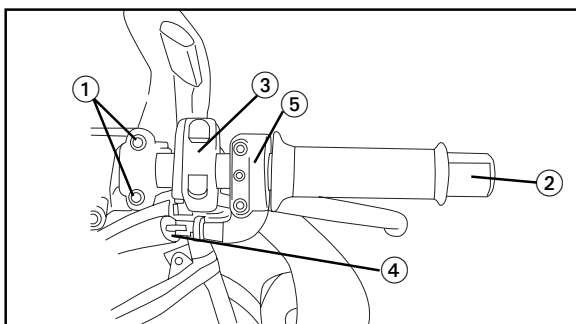

3. Remove:
 - The screws (brake pump support) ①
4. Dismantle:
 - The counterweight of the end of the handlebar (right-hand) ②
 - The switch of the handlebar on the right-hand side ③
 - The throttle cable ④
 - The throttle twist grip (right-hand) ④

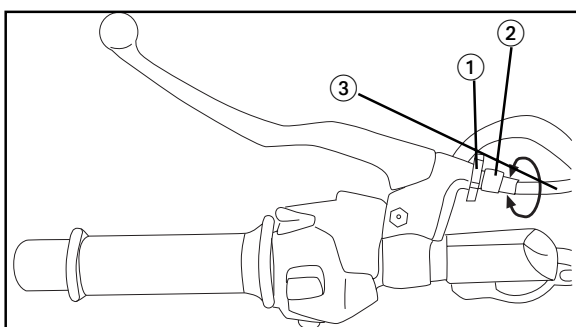

5. Loosen:
 - The locknut ①
 - The tensor ②
6. Dismantle:
 - The clutch cable ③

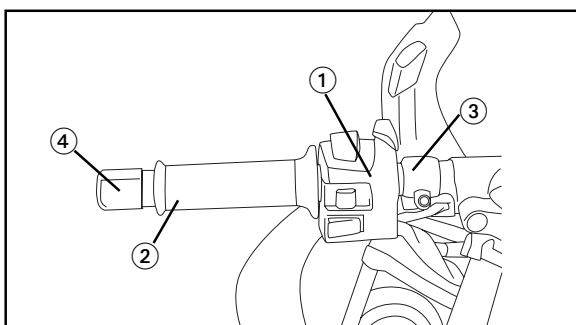

7. Dismantle:
 - The switch of the handlebar on the left-hand side ①
 - Twist grip (left-hand) ②
 - Support of the clutch lever ③
 - The handlebar counterweight (left-hand) ④

STEERING HEAD AND HANDLEBAR

CHAS

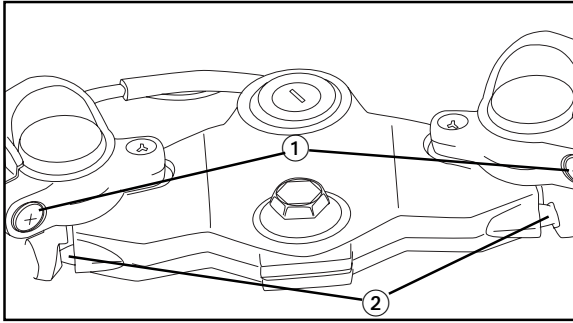

8. Loosen:
 - The clamp screws (handlebars) ①
9. Remove:
 - The screws (handlebars) ②
10. Dismantle:
 - The handlebars (left and right-hand)
11. Dismantle:
 - The fairing
See the section on “REMOVING THE FAIRING”
12. Dismantle:
 - The fork
See the section on “FRONT FORK - REMOVAL”
13. Dismantle:
 - The rear-view mirrors
14. Disconnect:
 - The headlight connectors
15. Remove:
 - The front of the fairing

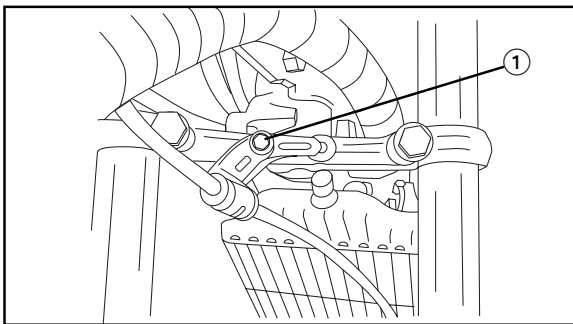

16. Dismantle:
 - The clamp of the brake line ①

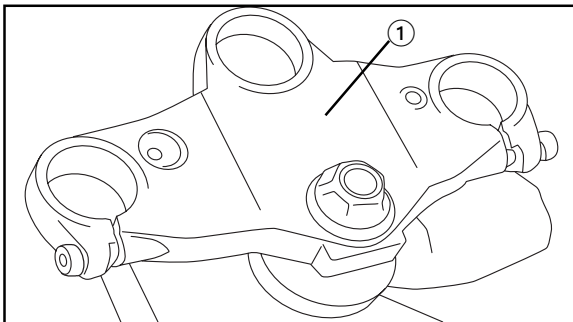

17. Dismantle:
 - The upper crown ①

STEERING HEAD AND HANDLEBARS

CHAS

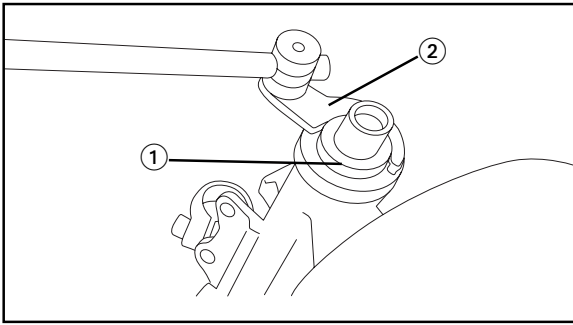

18. Remove:
- The ring nut ①
- Use the wrench for ring nuts ②



Wrench for annular nuts :
90890 - 01403

WARNING

Support the steering axle so that this cannot fall

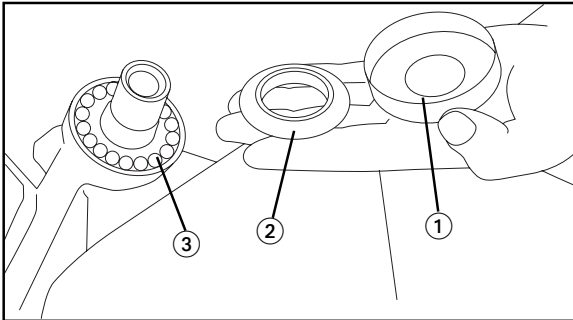

19. Dismantle:
- The cover of the bearing races ①
 - The upper race of the bearing ②
 - The balls ③

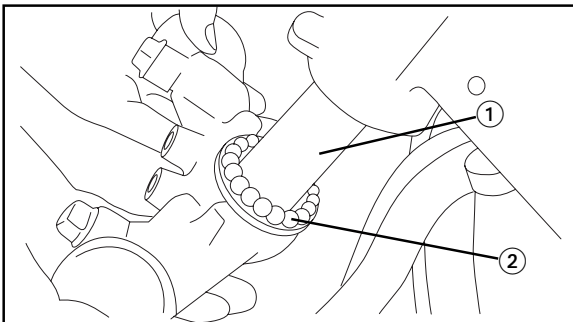

20. Dismantle:
- The steering axle ①
 - The ball bearings ②



INSPECTION

1. Wash the ball bearings and races with solvents.
2. Inspect:
 - The ball bearings
 - The bearing races
 Pitting / Damage → Replace

NOTE:

Always replace the bearings and races as a set

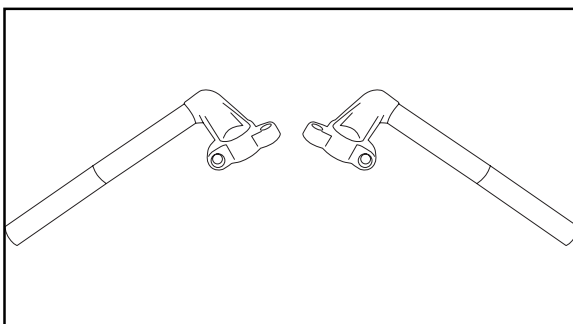
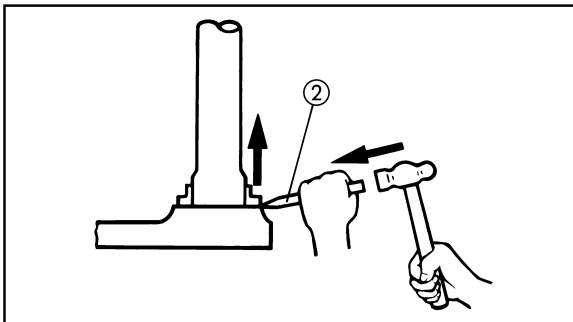
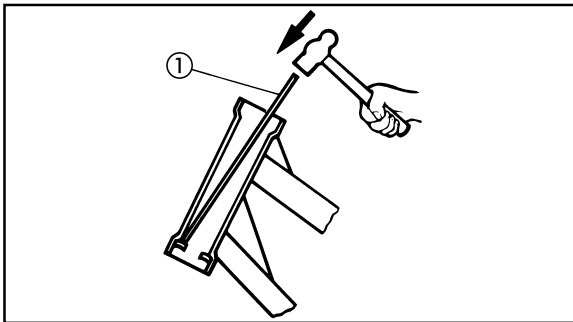

Replacement steps:

- Dismantle the bearing races from the steering arm with a long rod 1 and a hammer, as shown in the figure.
- Dismantle the bearing race fitted on the lower support with a chisel 2 and a hammer, as shown in the illustration.
- Install the new dust cover seal and the new races.

3. Inspect:
 - The handlebars
 Deformations / Cracks / Damage → Replace

⚠ WARNING

Do not attempt to straighten the handlebars if these are deformed as this could considerably weaken them

ASSEMBLY

Apply the procedure for “DISMANTLING” inversely.

Take into account the following points.

1. Apply :
 - Lithium soap grease to the bearing races

STEERING HEAD AND HANDLEBARS

CHAS

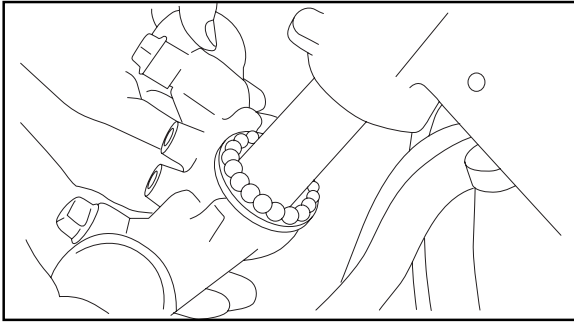

2. Install:
- The bearings
Install the balls on the race and apply more grease

N° and dimensions of the balls:
19 units above / 1/4 inch
19 units below 1/4 inch

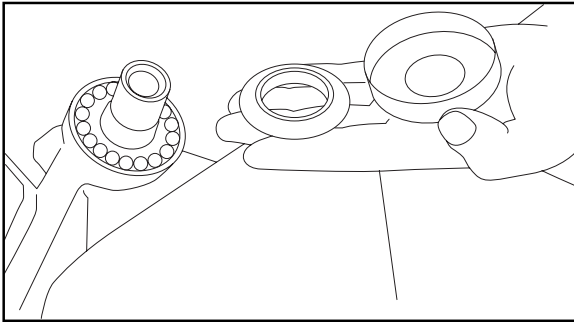

3. Install:
- The steering axle

⚠ WARNING

Immobilise the steering axle until this is fixed.

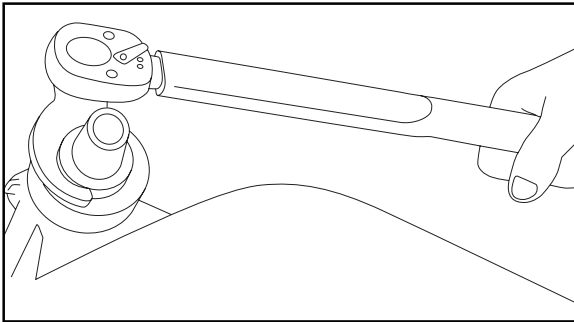

4. Tighten:
- The ring nut

Tightening steps:

- Tighten the annular nut using the wrench for annular nuts



Wrench for annular nuts:
90890 - 01403

NOTE:

Couple the torque wrench to the wrench for annular nuts so that these form a right angle.



Ring nut (initial tightening):
3.8 kg • m

- Turn the steering 2 or 3 times
- Loosen the nut half a turn
- Tighten the annular nut again with the special wrench

⚠ WARNING

Do not tighten excessively



Wrench for annular nuts:
0.7 kg • m

STEERING HEAD AND HANDLEBARS

CHAS

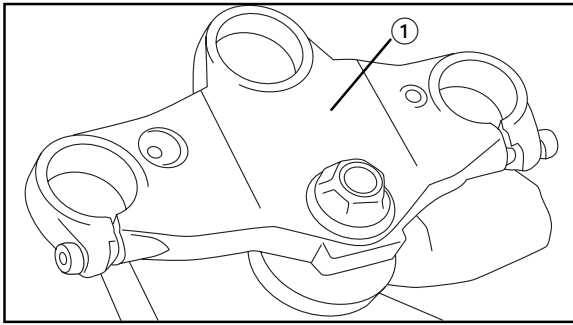

5. Install:
- The upper crown



Screw (steering axle):
5.4 kg • m

NOTE:

Provisionally tighten nut 2 of the steering axle.

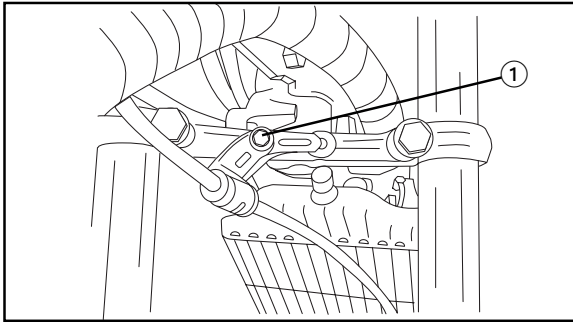

6. Install:
- The headlight support
 - The clamp of the brake line (1)



Screw (headlight support):
1.0 kg. • m

7. Install:
- The fork
- See the section on "FITTING THE FORK"



Clamp screw (steering axle):
3.0 kg • m
Clamp screw (upper shank of the handlebar):
2.0 kg • m

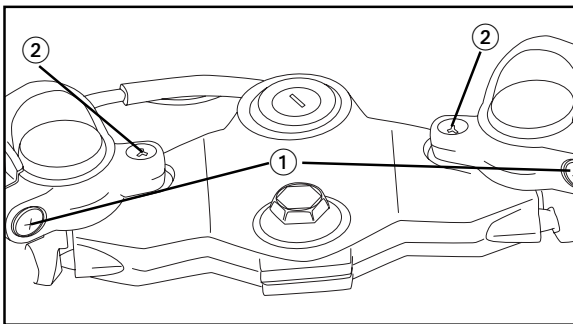

8. Install:
- The handlebars



Clamp screw (handlebar) (1)
2.0 kg • m
Screws (handlebar) (2):
0.9 kg • m

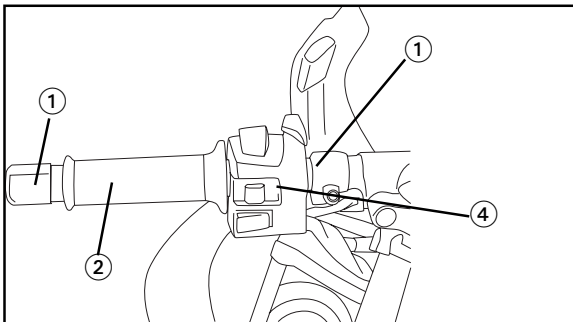

9. Install:
- The support of the clutch lever (1)
 - The twist grip (2) (left-hand)
 - The twist grip counterweight (left-hand) (3)
 - The control unit 4 of the left-hand twist grip

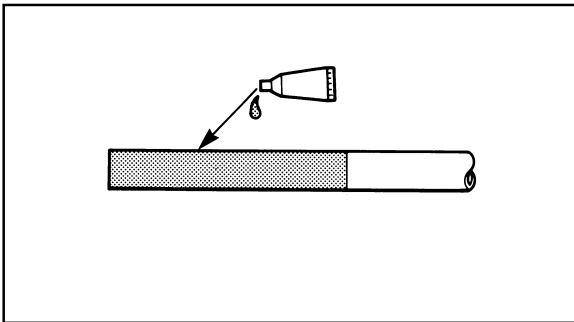
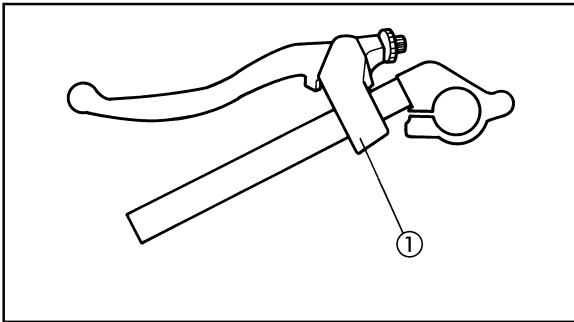

Stages in replacing the left-hand handlebar:

- Couple the lever support ① to the handlebar, as shown in the illustration.
- Align the mark of the handlebar with the support of the clutch lever.



Screw (handlebar support):
0.9 kg • m

- Apply a light layer of some special adhesive for rubber to the end of the handlebar, as shown in the illustration.
- Insert the twist grip into the end of the handlebar as far as it will go.

NOTE: _____

Clean off the excess adhesive with a clean cloth.

⚠ WARNING _____

Do not touch the handlebar until the adhesive has dried enough to ensure the twist grip is firmly adhered.

- Install the counterweight of the handlebar twist grip (left-hand)



Counterweight of the handlebar twist grip:
20 Nm (2.0 kg • m)

- Install the switches of the left-hand handlebar

10. Install:
- The twist grip (right-hand)
 - The throttle cable
 - The switches of the right-hand handlebar

NOTE: _____

Before installing the twist grip (right-hand), apply a light layer of lithium soap grease to the end of the handlebar.

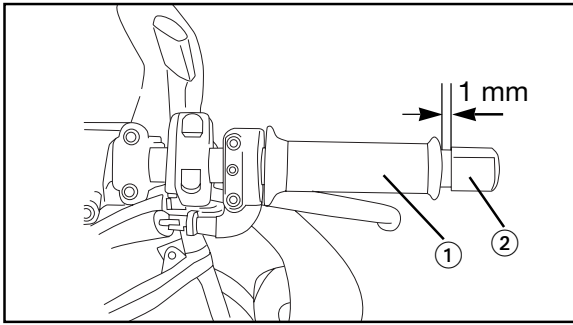

⚠ WARNING

Leave a space of 1 mm between the twist grip ① and the counterweight ②. Otherwise the twist grip could stick.

11. Install:
- The counterweight of the twist grip (right-hand) ②

	Counterweight of the twist grip: 2.0 kg • m
--	---

12. Install:
- The front brake pump

	Screw (brake pump support): 0.8 kg • m
--	--

13. Install:
- The front mudguard

	Screw: (Front mudguard): 0.8 kg • m
--	---

14. Install:
- The front wheel
See the section on "FRONT WHEEL - FITTING"

	Wheel axle: 6.5 kg • m
	Screw (brake caliper): 3.5 kg • m

15. Install:
- The clutch cable

NOTE:

Apply a light layer of lithium soap grease to the end of the clutch cable.

16. Install:
- The front of the fairing
17. Connect:
- The headlight connectors
18. Install:
- The rear view mirrors

STEERING HEAD AND HANDLEBARS

CHAS



19. Adjust:

- The free play of the clutch cable
See the section on “ADJUSTING THE CLUTCH” in CHAPTER 3



Free play:
10 ~ 15 mm

20. Install:

- The fairing
See the section on “FAIRING - FITTING”.



REAR SHOCK ABSORBER AND SWINGARM

- ① Swingarm
- ② Roller bearing
- ③ Thrust cover
- ④ Hub
- ⑤ Swinging arm axle
- ⑥ Self-locking nut
- ⑦ Cover
- ⑧ Chain protector
- ⑨ Bush
- ⑩ Flat washer
- ⑪ Bolt with washer
- ⑫ Full shock absorber
- ⑬ Bolt
- ⑭ Bush
- ⑮ Flat washer
- ⑯ Self-locking nut
- ⑰ Screw
- ⑱ Washer

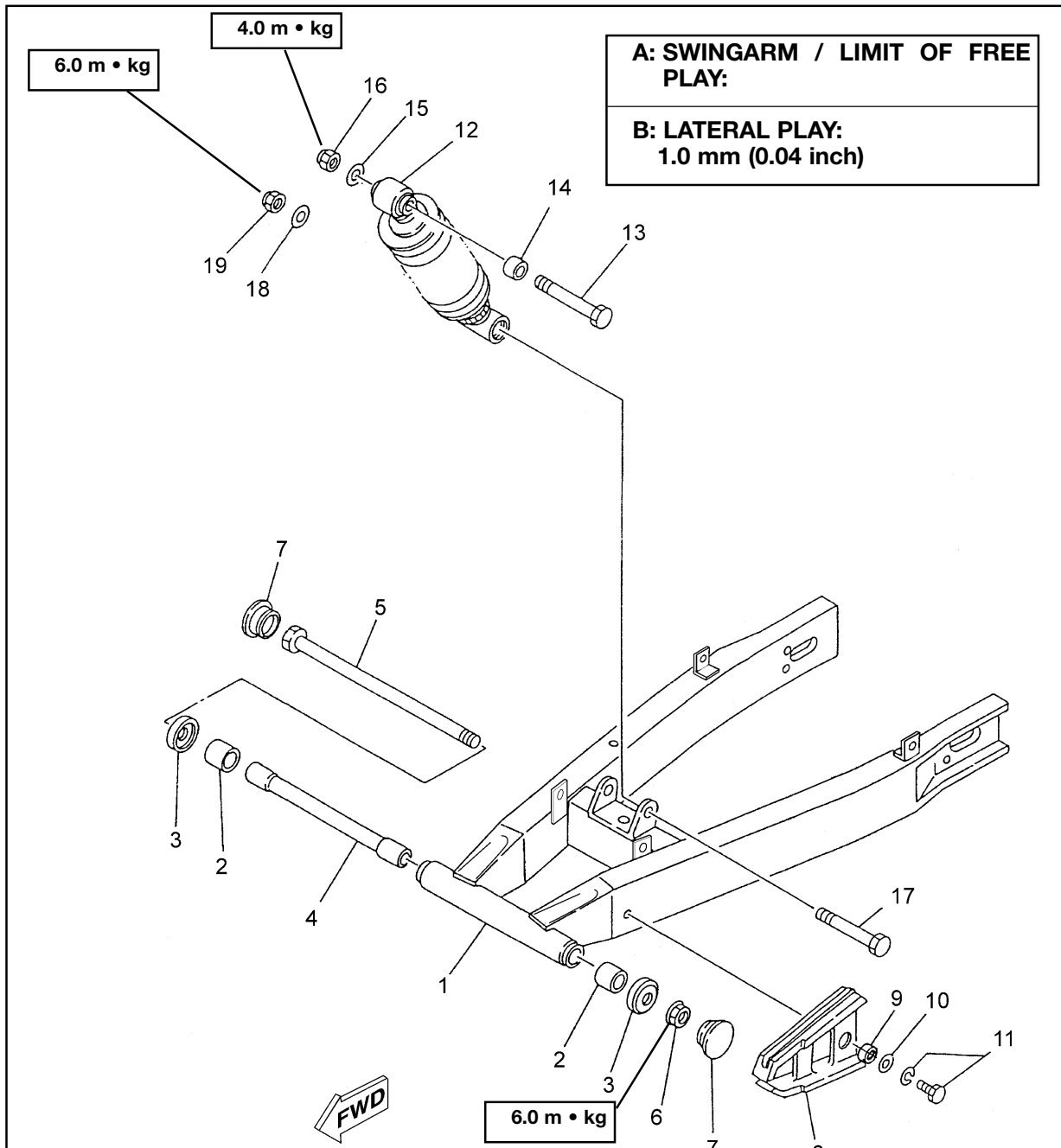



OBSERVATIONS ON HANDLING

⚠ WARNING

This shock absorber contains gaseous nitrogen at high pressure. Before handling it, read and understand the following information. The manufacturer will not accept any liability for damage to property or personal injuries stemming from improper handling.

- Do not tamper with or attempt to open the cylinder assembly.
- Do not let the shock absorber get in contact with flames or other sources of intense heat.
This could cause an explosion through excessive pressure.
- Do not deform the cylinder or allow this to deteriorate in any way. Any damage to the cylinder will reduce the efficiency of damping.
- Take care not to scratch the contact surface of the piston with the cylinder as there could be oil leaks.
- If you wish to get rid of the shock absorber see the section on "OBSERVATIONS ON ELIMINATION"

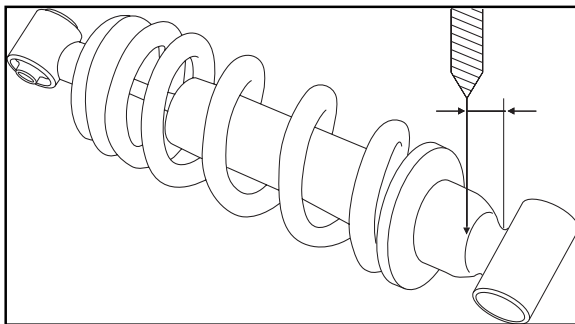

OBSERVATIONS ON ELIMINATION

Elimination steps:

Before throwing the shock away the gas under pressure should be released. Do this by making 1 a 2 ~ 3 mm hole in the wall of the cylinder at a point located 15 ~ 20 mm from the end of the gas chamber.

⚠ WARNING

Use protective glasses to prevent eye injuries caused by the escaping gas and/or shreds of metal.



DISMANTLING Rear swingarm

⚠ WARNING

Stand the motorcycle up firmly so that it does not fall over.

1. Dismantle:
 - The seat
 - The side covers or cowlings (left and right-hand)
See the section on "SIDE COVERS - DISMANTLING" in CHAPTER 3.
2. Lift up the rear wheel, installing an appropriate support under the engine.

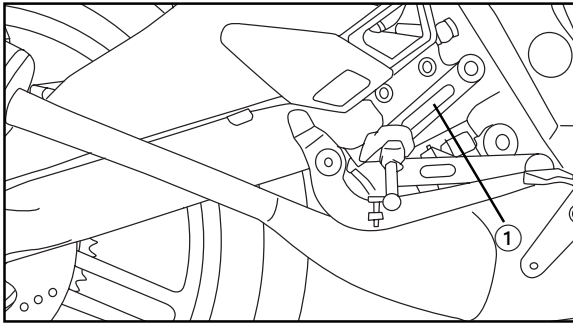

3. Dismantle:
 - The rear wheel
See section on "REAR WHEEL - DISMANTLING"
4. Dismantle:
 - The footrest support (left and right-hand) ①
 - The chain guard

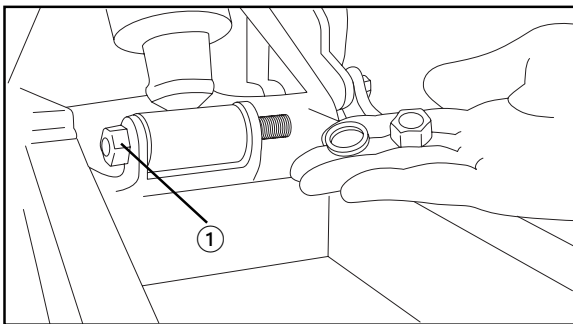

5. Remove:
 - The screw (rear-lower shock absorber) ①

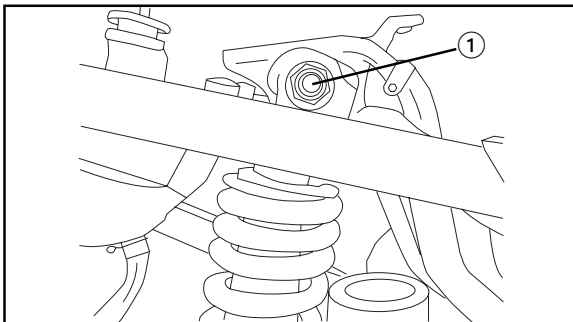

6. Remove:
 - The screw (rear- upper shock absorber) ①



Swingarm

⚠ WARNING

Stand the motorcycle up firmly so that it does not fall over.

1. Lift up the rear wheel, installing an appropriate support under the engine.
2. Dismantle:
 - The rear shock absorber
3. Dismantle:
 - The rear wheel

See the section on "REAR WHEEL - DISMANTLING"

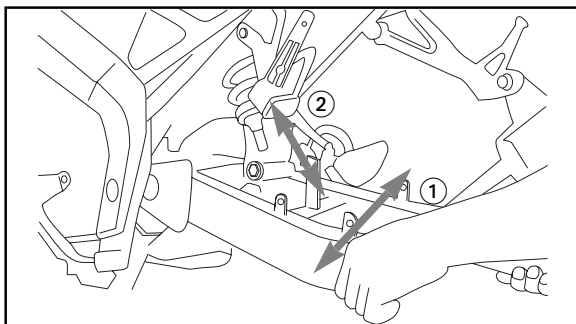

4. Check:
 - The swingarm (lateral play) ①
Move the swinging arm from one side to another.
Out of specification → Change the bearings



Lateral play (at the end of the swinging arm):
1.0 mm

5. Check:
 - The swingarm (vertical oscillation) ②.
Move the swingarm up and down.
Difficult to move / sticking / scraping → replace the bearings

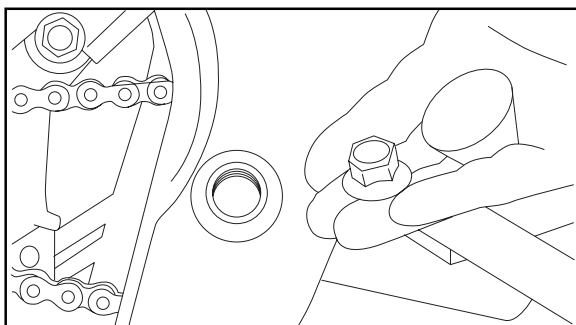

6. Dismantle:
 - The covers of the swingarm axle
 - The swingarm axle
7. Dismantle:
 - The swingarm

REAR SHOCK ABSORBER AND SWINGARM

CHAS

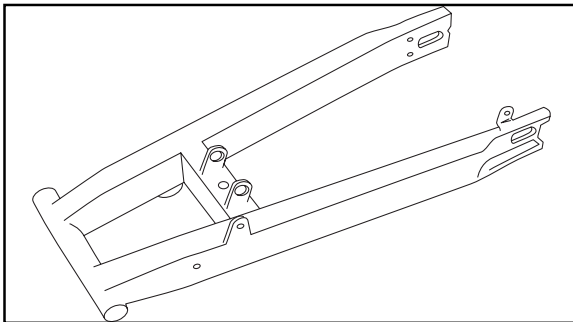
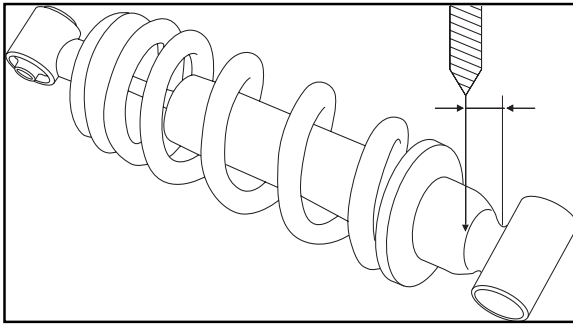

INSPECTION

1. Inspect:
 - The shock absorber
Oil leaks / damage → replace
2. Inspect:
 - The swingarm
Deformations / Cracks / damage → replace
3. Inspect:
 - The oil seals
Damage → Replace
 - The thrust covers
Damage → Replace
 - The bushes
Scratches / Damage → Replace
 - The bushes
Pitting / Damage → Replace

INSTALLING

Swingarm

Apply the same procedure as for “DISMANTLING” but inversely.

Take into account the following points:

1. Apply:
 - Lithium soap grease
to the oil seals, the bushes and the inside of the thrust covers.
2. Install:
 - The swingarm



Swingarm axle:
7.4 kg • m



Rear shock absorber

Apply the same procedure as in “DISMANTLING” but inversely.

Take into account the following points:

1. Apply:
 - Lithium soap grease to the oil seals and bush

2. Install:
 - The rear shock absorber



Rear shock absorber - upper:

6.0 kg • m

Rear shock absorber- lower:

6.0 kg • m

3. Install:
 - The rear wheel
See the section on “REAR WHEEL - FITTING”



Nut (wheel axle):

9.0 kg • m

4. Adjust:
 - The tension of the drive chain. See the section on “TIGHTENING THE TRANSMISSION CHAIN” in CHAPTER 3.



Tension of drive chain

20 ~ 25 mm

REAR WHEEL SPROCKET AND DRIVE CHAIN

- ⑤ Rear sprocket
- ⑥ Holder
- ⑩ Drive chain
- ⑪ Chain coupling

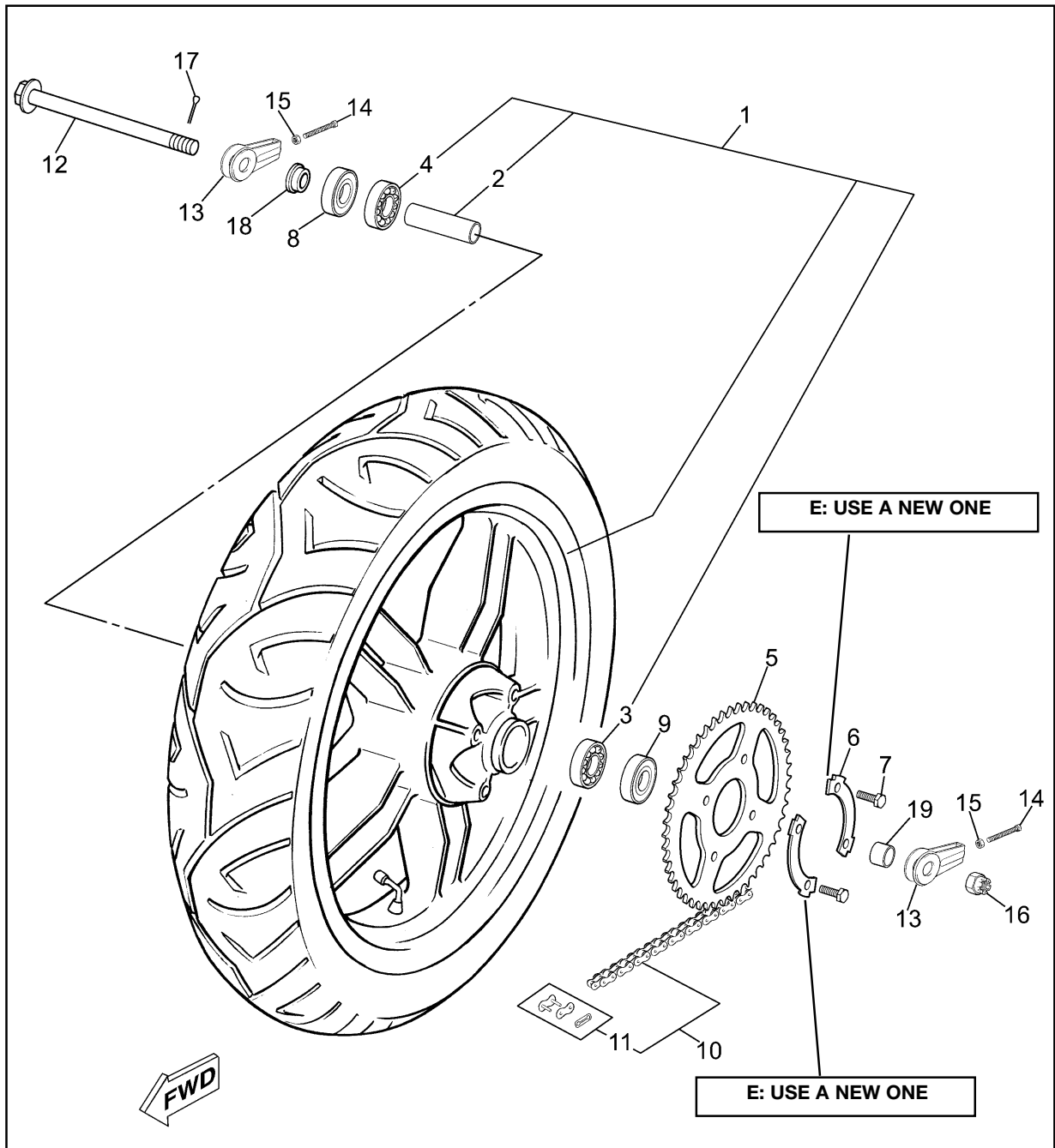

REAR WHEEL SPROCKET AND DRIVE CHAIN

CHAS



NOTE:

Before dismantling the sprocket, the chain and the rear wheel sprocket, the chain slack should be checked.

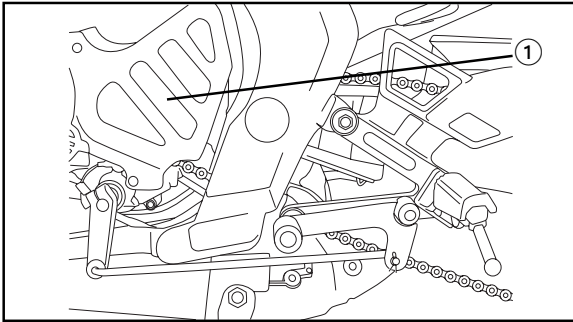

DISMANTLING

1. Dismantle:
 - The cover of the output sprocket (1)

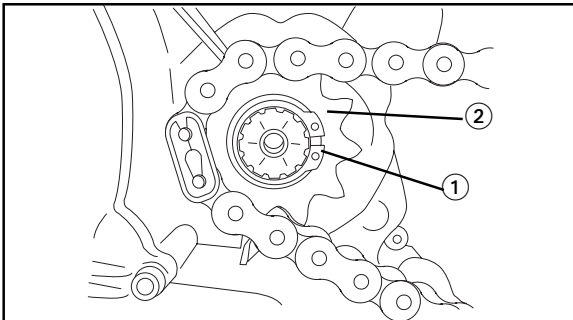

2. Dismantle
 - The circlip (1)
 - The sprocket (2)

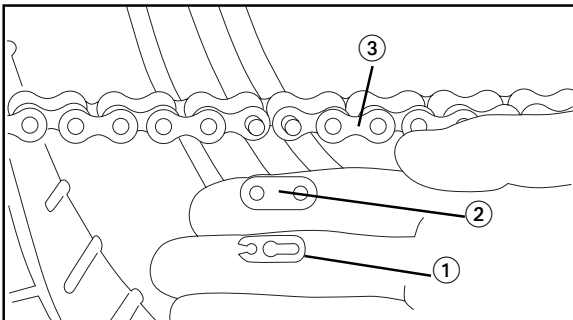

3. Dismantle:
 - The retaining clip (1)
 - The coupling plate (2)

4. Dismantle:
 - The drive chain (3)

5. Dismantle:
 - The rear wheel
See the section on "REAR WHEEL - DISMANTLING"

REAR WHEEL SPROCKET AND DRIVE CHAIN

CHAS

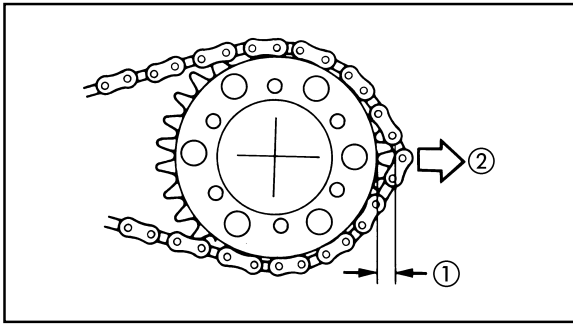

INSPECTION

1. Check:
 - The chain stretching
Pull the chain to separate this from the crown wheel.
Distance between chain/crown wheel greater than half the tooth ① → replace the chain.

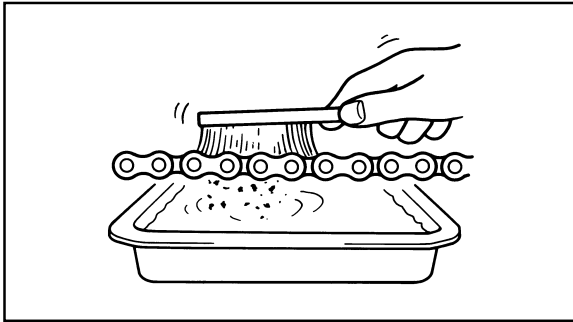

2. Clean:
 - The drive chain
Submerge this in solvent and use a brush to clean off as much dirt as possible. Then take the chain out of the solvent and dry it.

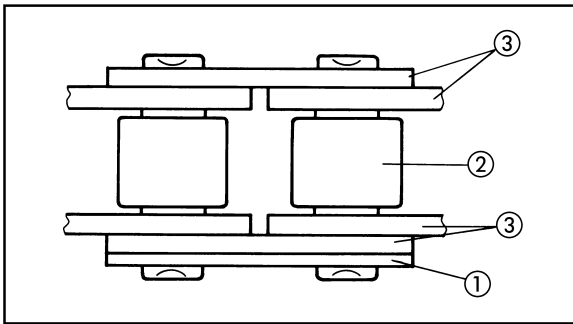

3. Inspect:
 - The clip ① (Drive chain)
Damage → Replace the drive chain
 - The rollers ②
 - The side plates ③
Damage / Wear → Replace the drive chain

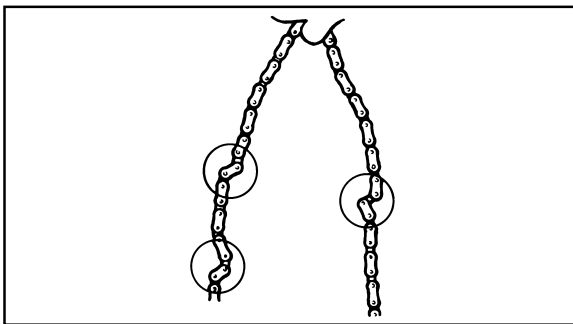

4. Check:
 - Chain sticking
Clean and grease the chain and hold this as shown in the illustration.
Sticking → Replace the chain

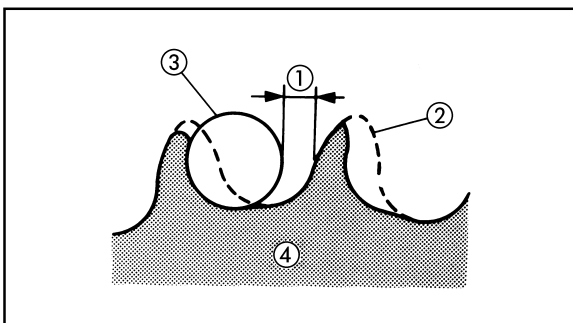

5. Inspect:
 - The sprocket and rear wheel sprocket
Wear / damage → replace

- ① 1/4 tooth
- ② Correct
- ③ Roller
- ④ Rear wheel sprocket

REAR WHEEL SPROCKET AND DRIVE CHAIN

CHAS

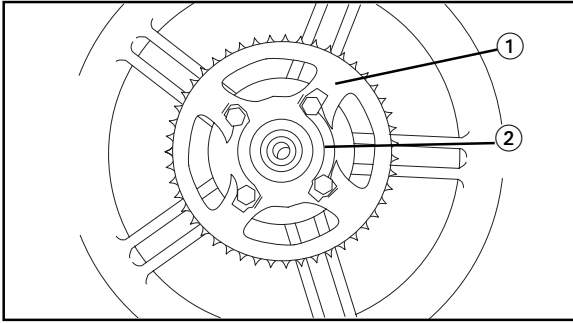

Replacing steps:

- Straighten the tab of the locknut and take off the crown wheel ①
- Install the new rear wheel sprocket and the locknut ②



Nut (rear crown wheel sprocket):
6.3 kg • m

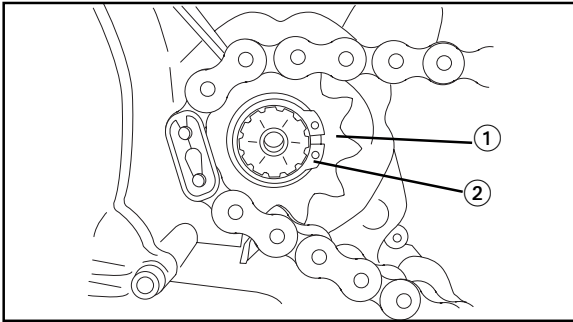

ASSEMBLY

Apply the procedure for “DISMANTLING” inversely.

Bear in mind the following points:

1. Install:
 - The sprocket ①
 - The circlip ②
2. Install:
 - The sprocket cover ①

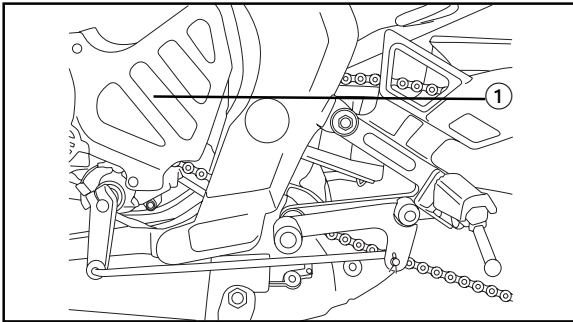

Screw (sprocket cover):
0.5 kg • m
Screw (sender)
1.0 kg • m

3. Install:
 - The rear wheel
See the section on “REAR WHEEL - FITTING”



Nut (wheel axle):
9.0 kg • m

REAR WHEEL SPROCKET AND DRIVE CHAIN

CHAS

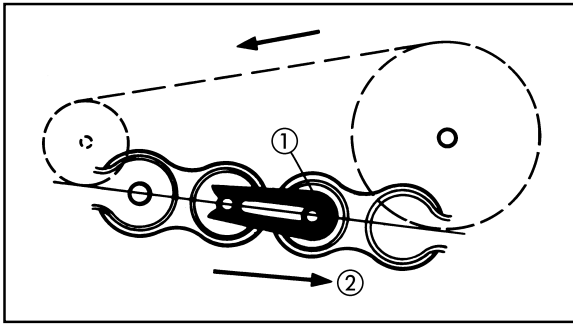

4. Install:
 - The drive chain
 - The coupling link of the chain
 - The chain clip ①

② Rotation direction

⚠ WARNING

Make sure that the clip is installed in the right position. Otherwise the transmission chain would open.

5. Adjust:
 - The chain slack
See the section on “TIGHTENING The TRANSMISSION CHAIN” in CHAPTER 3.



Drive chain slack:
20 ~ 25 mm

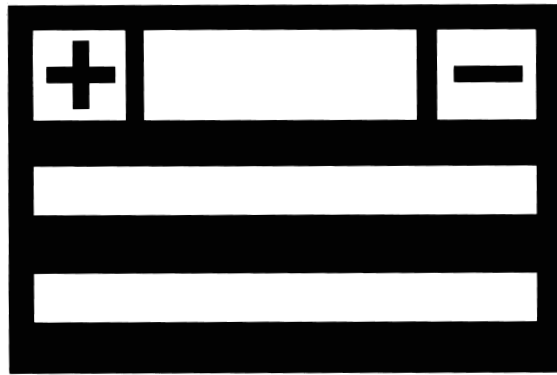

ELEC

8

CHAPTER 8
ELECTRICAL SYSTEM

ELECTRICAL DIAGRAM8-2

ELECTRICAL COMPONENTS8-4

IGNITION AND STARTING SYSTEM8-6

ELECTRIC STARTING SYSTEM8-8
TROUBLESHOOTING8-9

CHARGING SYSTEM8-12
TROUBLESHOOTING8-14

LIGHTING SYSTEM8-18
LOCATING BREAKDOWNS8-20
CHECKING AND TESTING THE LIGHTING SYSTEM8-23

SIGNALING SYSTEM8-28
TROUBLESHOOTING8-30
CHECKING AND TESTING THE SIGNALING SYSTEM8-32

COOLING SYSTEM8-46
TROUBLESHOOTING8-48

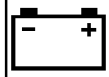

ELECTRICAL DIAGRAM

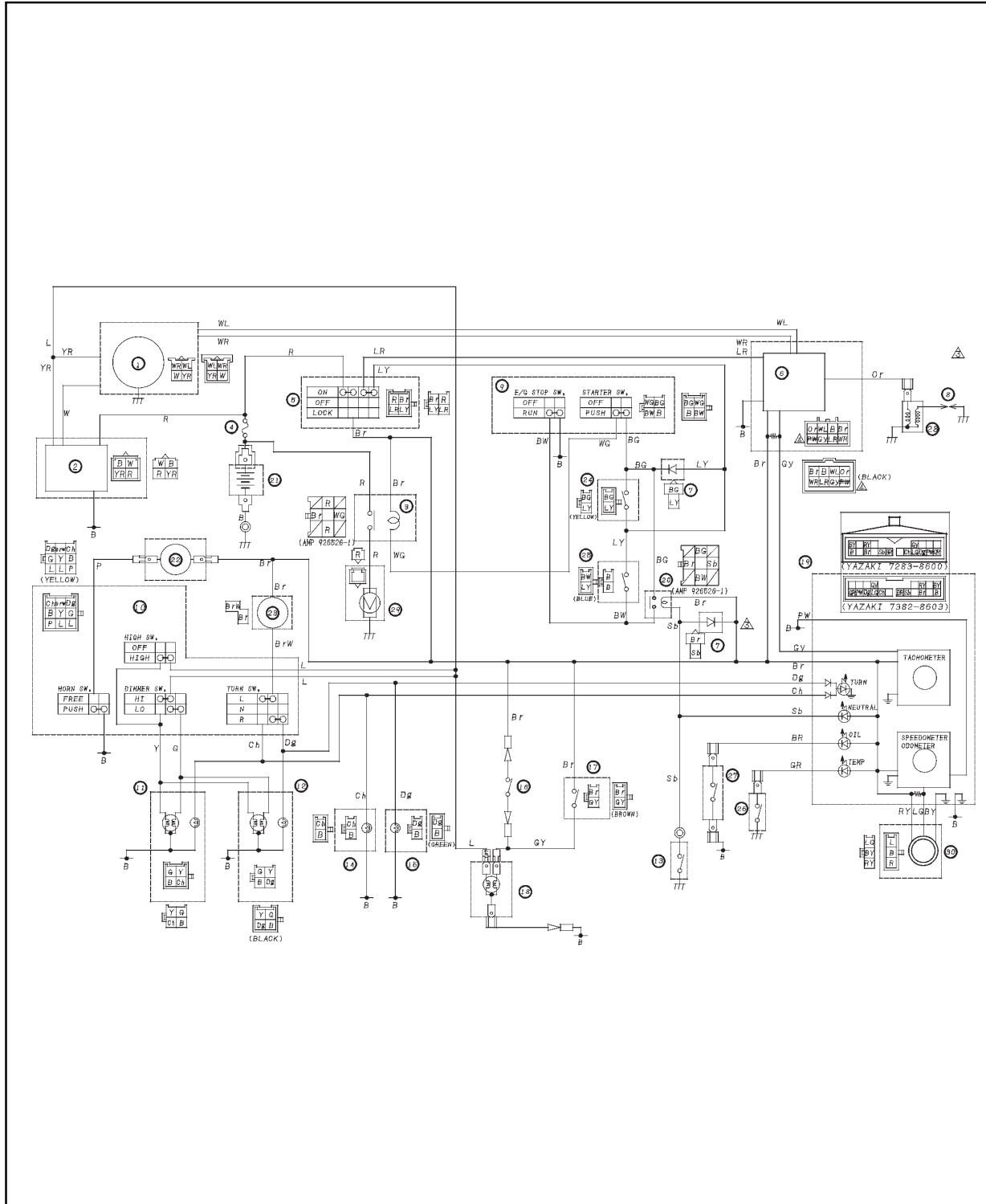

ELECTRICAL DIAGRAM

ELEC

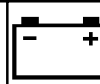

- | | |
|---|--|
| <ul style="list-style-type: none"> ① Magnetic flywheel ② Regulator / Rectifier ③ Starting relay ④ Fuse ⑤ Main switch ⑥ CDI ⑦ Diode x 2 ⑧ Spark plug ⑨ Handlebar switch (rh) ⑩ Handlebar switch (lh) ⑪ Front headlight / flasher (lh) ⑫ Front headlight (flasher rh) ⑬ Neutral switch ⑭ Rear indicator (lh) ⑮ Rear indicator (rh) | <ul style="list-style-type: none"> ⑯ Front brake switch ⑰ Rear brake switch ⑱ Tail light ⑲ Instrument panel ⑳ Neutral relay ㉑ Battery ㉒ Horn ㉓ Flasher relay ㉔ Clutch switch ㉕ Side stand switch ㉖ Thermocontact ㉗ Oil level switch ㉘ Coil ㉙ Starter motor ㉚ Speedometer sensor |
|---|--|

B	Black	B/Br	Black/(brown	W/R	White/Red
R	Red	Sb	Sky blue	W/B	White/Black
O	Orange	Br	Brown	W/G	White/Green
L	Blue	L/B	Blue/Black	Y/L	Yellow/Blue
P	Pink	L/W	Blue/White	Y/R	Yellow/Red
Y	Yellow	L/Y	Blue/Yellow	G/R	Green/Red
G	Green	B/Y	Black/Yellow	G/Y	Green/Yellow
W	White	B/W	Black/White	Br/W	Brown/White
Ch	Chocolate	B/R	Black/Red	L/R	Blue/Red
Dg	Dark green	B/L	Black/Blue	Y/B	Yellow/Black

ELECTRICAL COMPONENTS (1)

- ① CDI
- ⑤ Spark plug pipe
- ⑥ Neutral switch
- ⑦ O ring
- ⑧ Thermostat switch
- ⑨ Starter motor
- ⑫ Battery
- ⑮ Regulator/Rectifier
- ⑰ Main switch
- ⑳ Rear brake light switch

STARTER COIL
PRIMARY COIL RESISTANCE:
 0.23 W + 20°C
SECONDARY COIL
RESISTANCE:
 7.9 K W

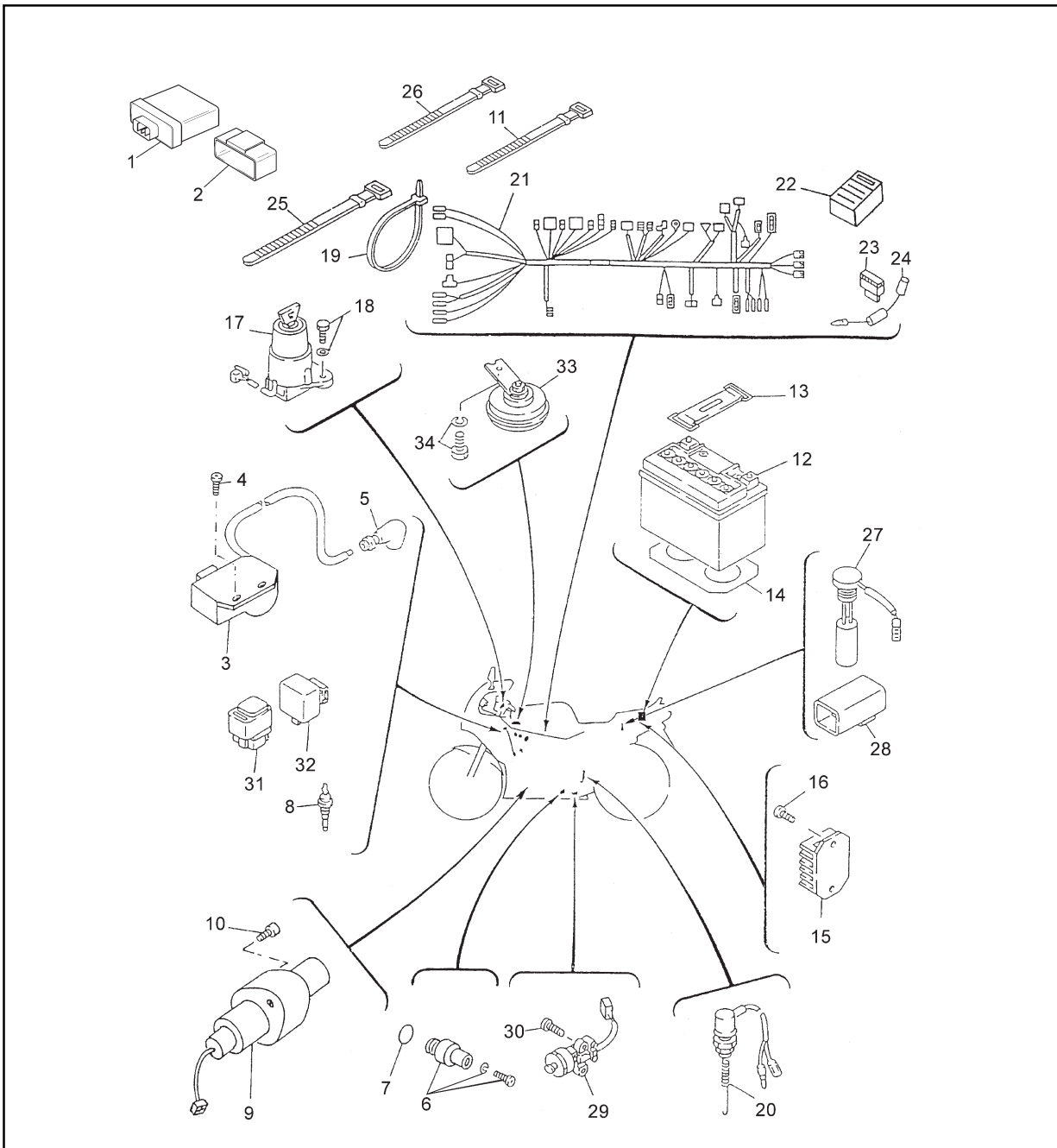

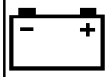

ELECTRICAL COMPONENTS (1)

- ②① Electrical installation
- ②③ Fuse
- ②④ Diode
- ②⑦ Oil level switch
- ②⑨ Side stand switch
- ③① Relay
- ③② Indicator flasher relay
- ③③ Horn

BATTERY:
CAPACITY:
 12 V 3AH
NO MAINTENANCE

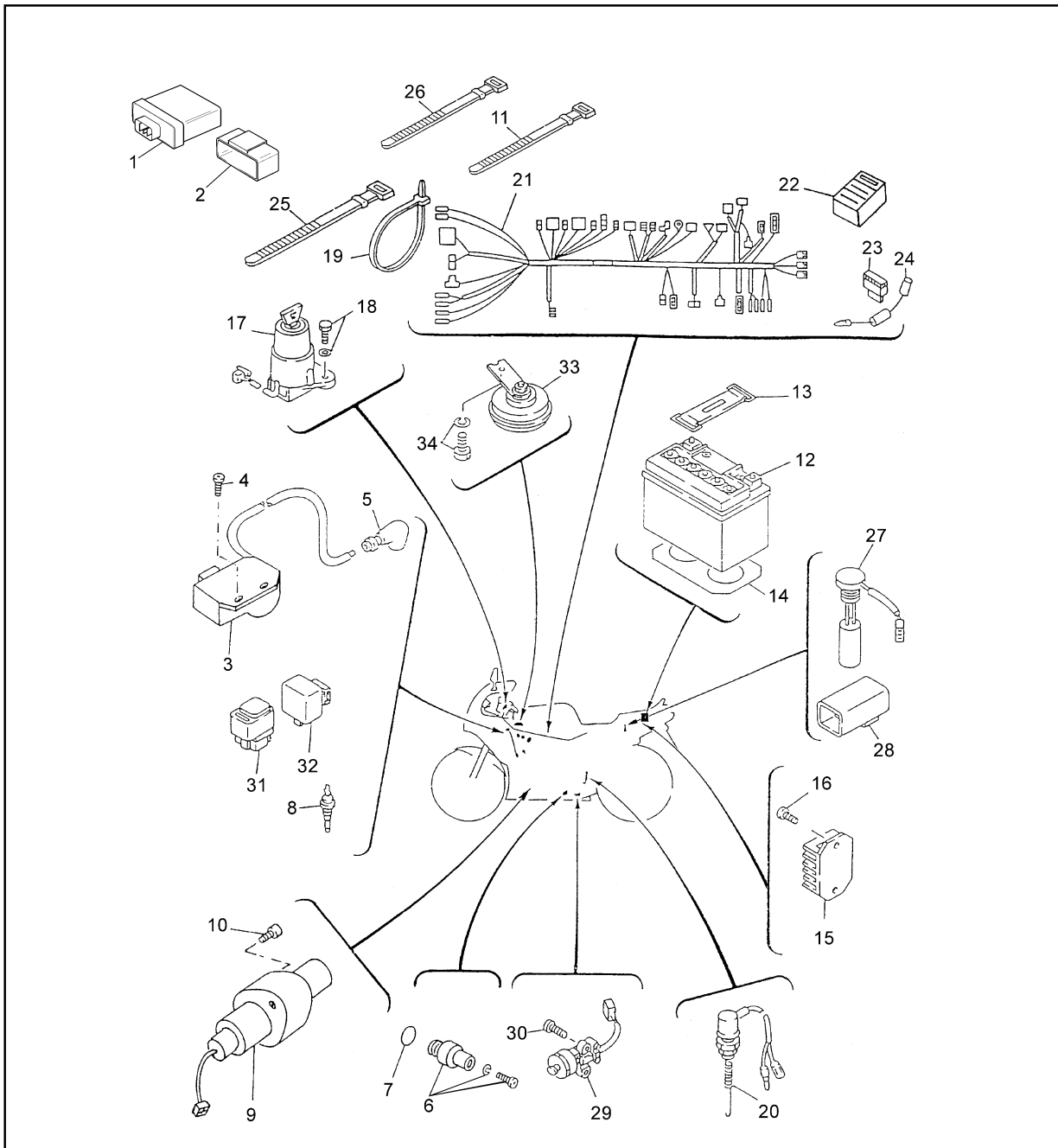

IGNITION AND STARTING SYSTEM

ELEC

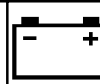

NOTE: _____

For the colour codes, please see the electrical diagram

- ① C.D.I. magneto
- ③ Starter relay
- ⑤ Main switch
- ⑥ C.D.I.
- ⑧ Spark plug
- ⑨ Handlebar switch (RH)
- ⑲ Battery
- ⑳ Coil
- ㉑ Starter motor

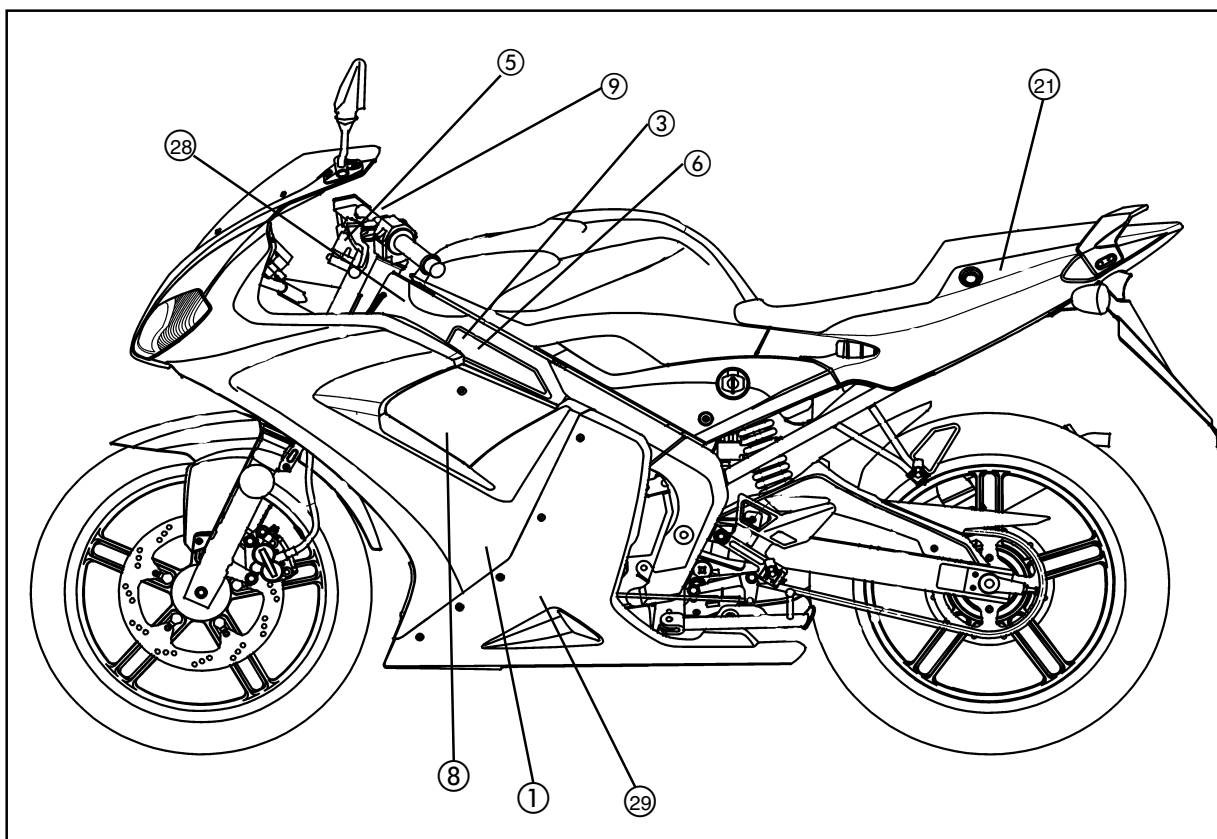



**ELECTRIC START SYSTEM
CIRCUIT DIAGRAM**

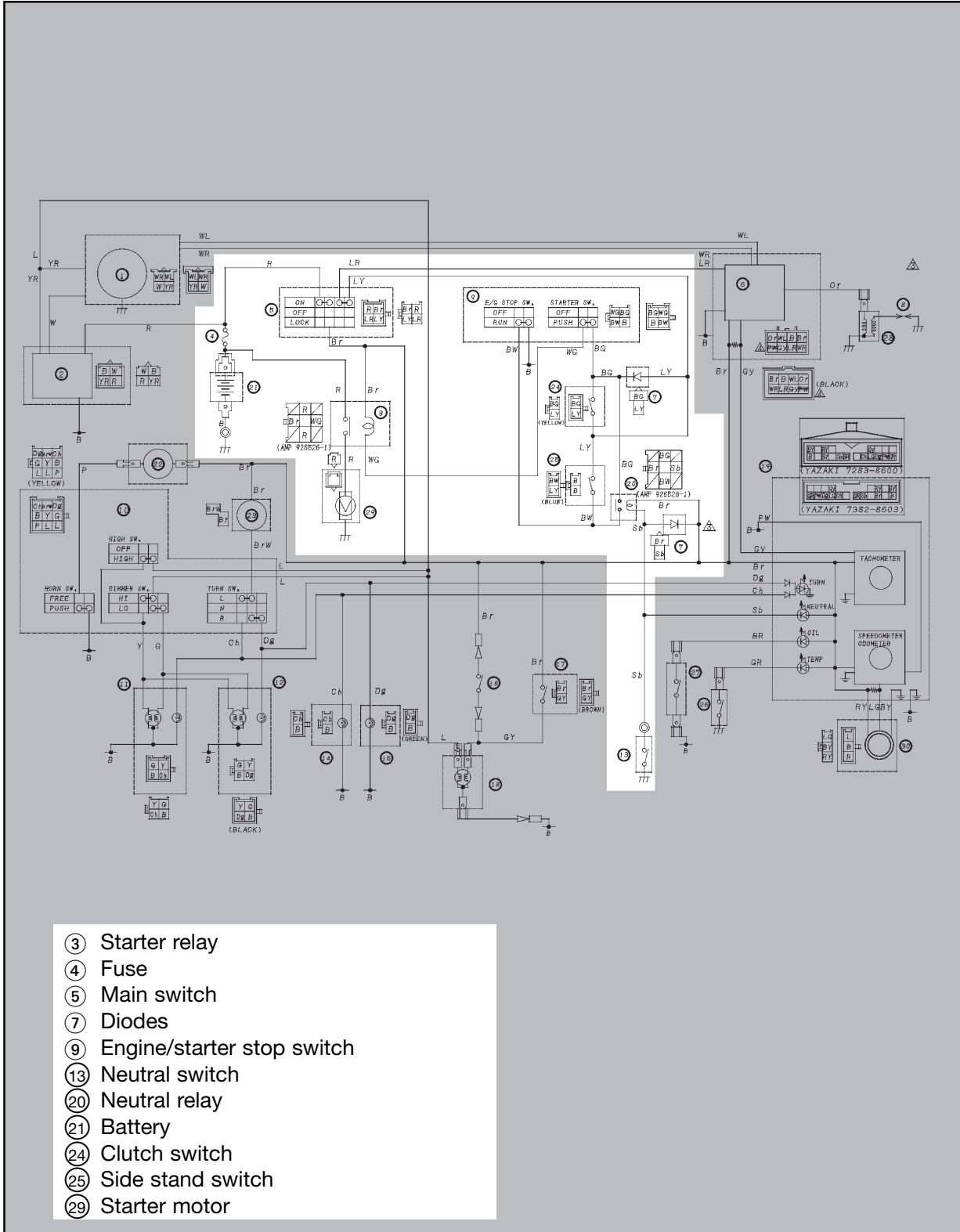

- ③ Starter relay
- ④ Fuse
- ⑤ Main switch
- ⑦ Diodes
- ⑨ Engine/starter stop switch
- ⑬ Neutral switch
- ⑳ Neutral relay
- ㉑ Battery
- ㉔ Clutch switch
- ㉕ Side stand switch
- ㉙ Starter motor

TROUBLESHOOTING



THE STARTER MOTOR DOES NOT WORK

NOTE: _____

- Use the following tools in this fault location



	Pocket tester: 90890 -03112
---	--

1. Fuse (main) <ul style="list-style-type: none"> • Check the condition of the fuse. See "INSPECTING THE FUSE" in CHAPTER 3.

OK  NOT OK 

Change the fuse

2. Battery <ul style="list-style-type: none"> • Check the condition of the battery. See "INSPECTING THE BATTERY" in CHAPTER 3.

OK  NOT OK 

Charge or change the battery

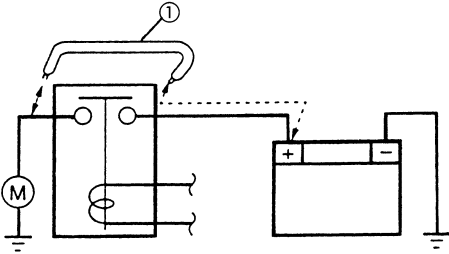
3. Starter motor 
<ul style="list-style-type: none"> • Connect a bridge ① • Check the operation of the starter motor



OK  NOT OK 

Repair or change the starter motor

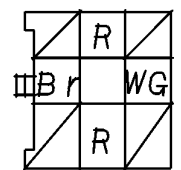
4. Neutral relay <ul style="list-style-type: none"> • Remove the relay

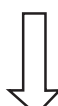

- Use the battery to supply terminals Br and Sb.
- Then check the continuity between GB and BW



OK  NOT OK 

Change the neutral relay

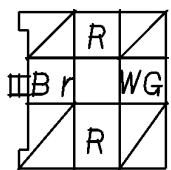
5. Starter relay <ul style="list-style-type: none"> • Remove the relay



- Use the battery to supply terminals Br and WG.
- Check the continuity between R and R

OK  NOT OK 

Change the starter relay

ELECTRIC START SYSTEM

ELEC

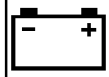

6. Main switch

- Place in the ON position

- Separate the connections
- Check the continuity between R and Br

OK ↓ NOT OK ↓

Repair the main switch

8. Neutral switch

- Check the continuity:
- Light blue ① → ground

OK ↓ NOT OK ↓

Change the neutral switch

7. Engine kill switch

- Place in RUN position (not pressed)

- Separate connections
- Check the continuity between BW and B.

OK ↓ NOT OK ↓

Repair the handlebar switch (Right)

9. Side stand switch

- Separate the blue connection
- Fold up the side stand

- Check the continuity between B and B

OK ↓ NOT OK ↓

Repair the side stand switch

10. Clutch switch

- Separate the yellow connection

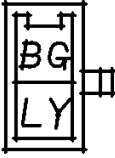

- Press the clutch
- Check the continuity between BG and LY

OK  NOT OK 

Repair the side stand switch

11. Starter switch

- Separate the connection
- Press the switch

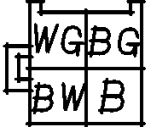

- Check the continuity between WG and BG

OK  NOT OK 

Change the handlebar switch (right hand)

12. Connections of the system

- Check all the connections of the starting system.
See "CIRCUIT DIAGRAM"

OK  NOT OK 

Correct

CHARGING SYSTEM

ELEC

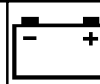

NOTE: _____

For the colour codes please see the electrical diagram

- ① C.D.I. magneto
- ② Regulator / Rectifier
- ④ Fuse
- ⑥ CDI
- ⑧ Spark plug
- ⑳ Battery
- ㉘ Coil

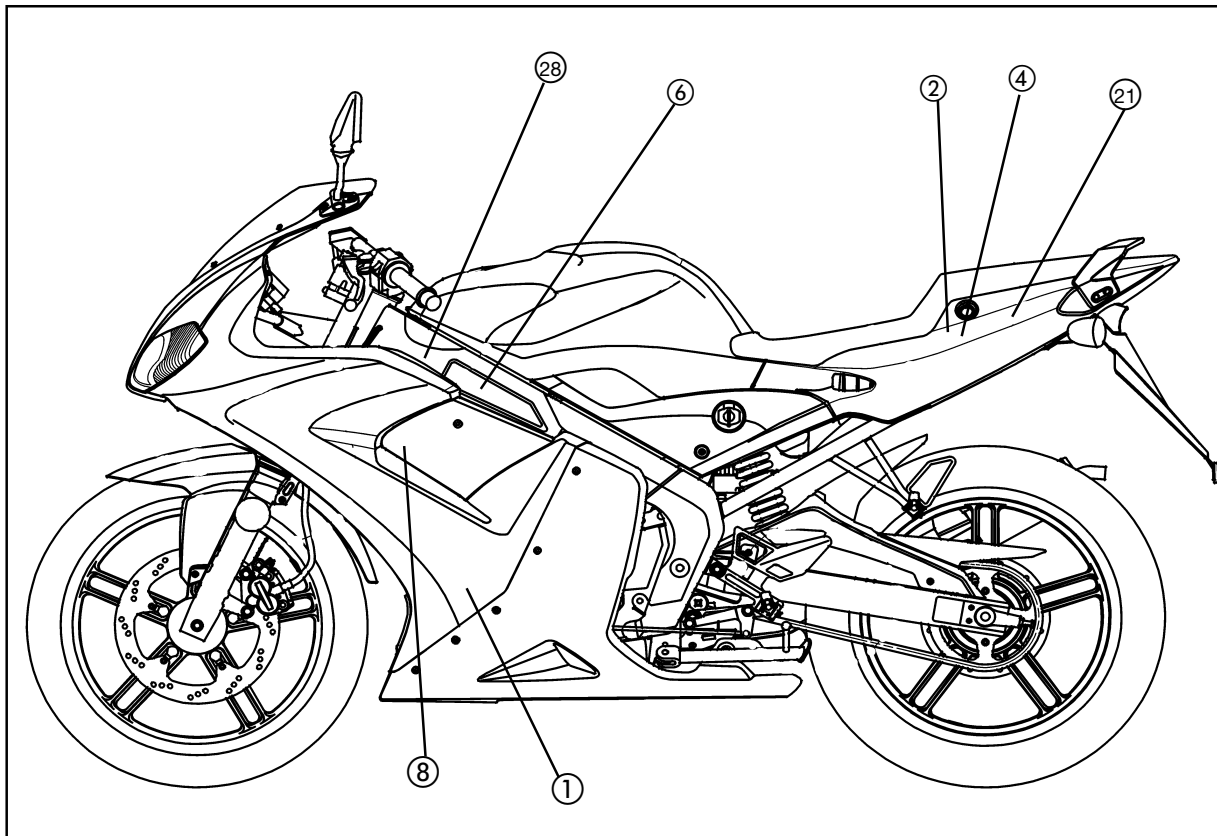

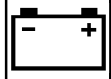

TROUBLESHOOTING

THE BATTERY IS FLAT

Procedure (1)

Check:

- | | |
|-------------------------|--|
| 1. The fuse | 4. The resistance of the stator coil |
| 2. The battery | 5. The cable connections (charge system) |
| 3. The charging voltage | |

NOTE:

- Dismantle the following components, before locating the fault.
 - 1) The seat
 - 2) The fuel tank
- To solve these problems use the following special tools:



Pocket tester:
90890-03112



Tachometer for engine:
90890 - 03113

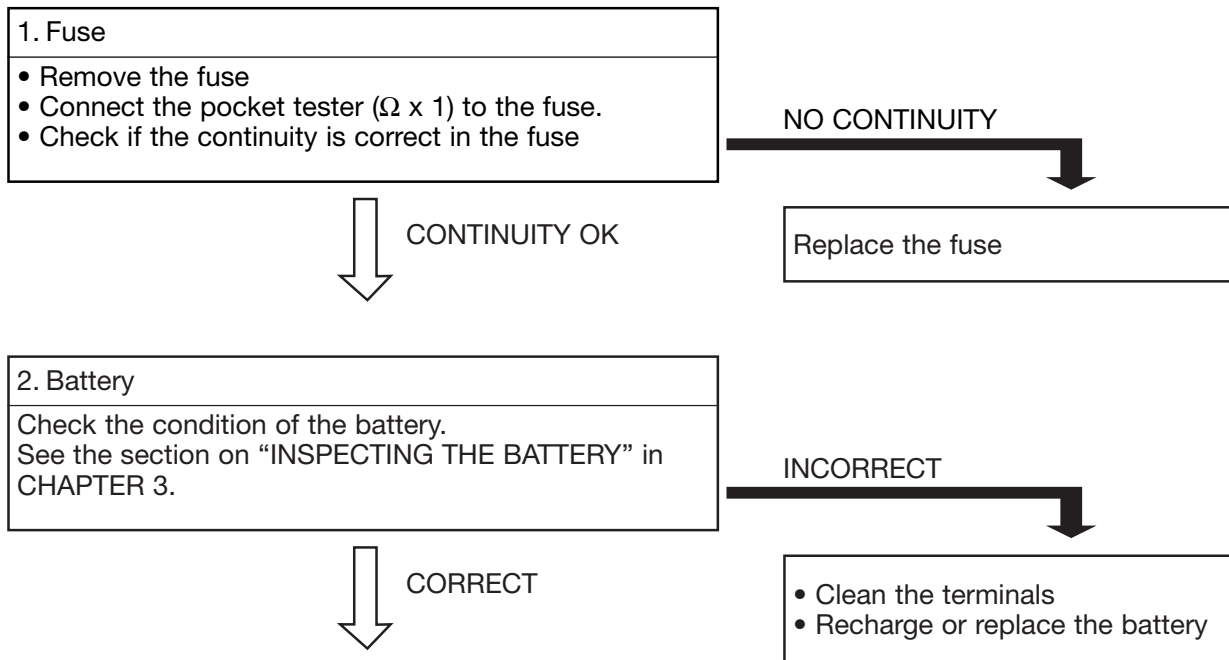

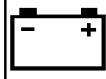

*



3. Charging voltage	
<ul style="list-style-type: none"> • Connect the engine tachometer to the spark plug cable • Connect the pocket tester (DC, 20V) to the battery 	
<p>(+) probe of tester → (+) terminal of the battery (-) probe of tester → (-) terminal of the battery</p>	
<ul style="list-style-type: none"> • Start the engine up and rev. up to about 3.000 r/min. • Check the charge voltage 	
	<ul style="list-style-type: none"> • Charge voltage: 14.0 V at 5000 rpm

MATCHES SPECIFICATION

Replace the battery



DOES NOT MATCH SPECIFICATIONS

4. Resistance of the stator coil.	
<ul style="list-style-type: none"> • Disconnect the stator coil coupler from the connector. • Connect the pocket tester ($\Omega \times 1$) to the stator coil. 	
<p>Stator coil: (+) probe of tester → Yellow-black terminal (-) probe of tester → White terminal</p>	

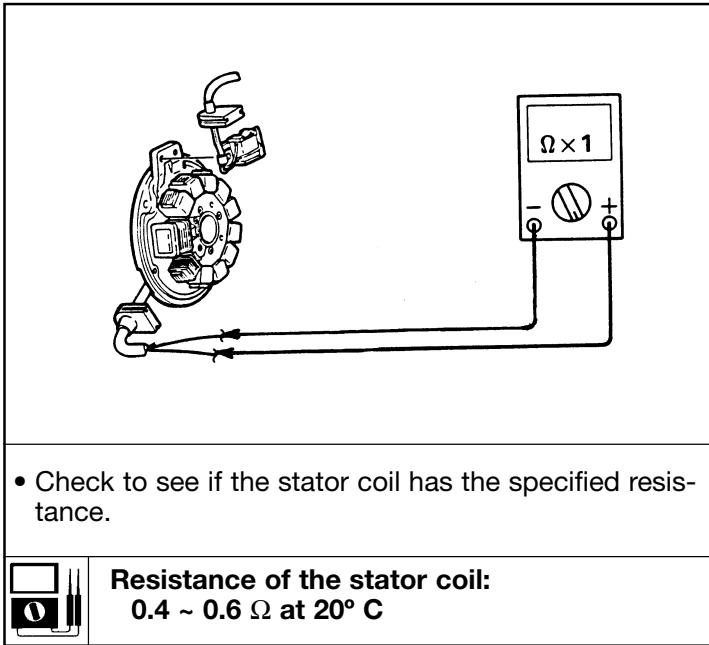
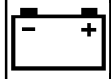

DOES NOT MATCH SPECIFICATION

Replace the stator coil

MATCHES SPECIFICATION

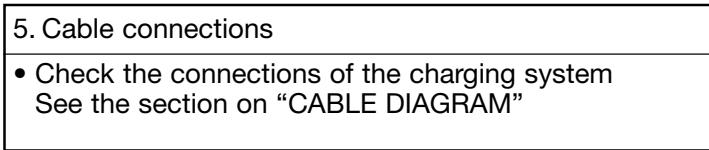

BAD CONNECTIONS

Correct these.

CORRECT

Change the rectifier / regulator

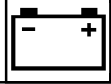

LIGHTING SYSTEM CIRCUIT DIAGRAM

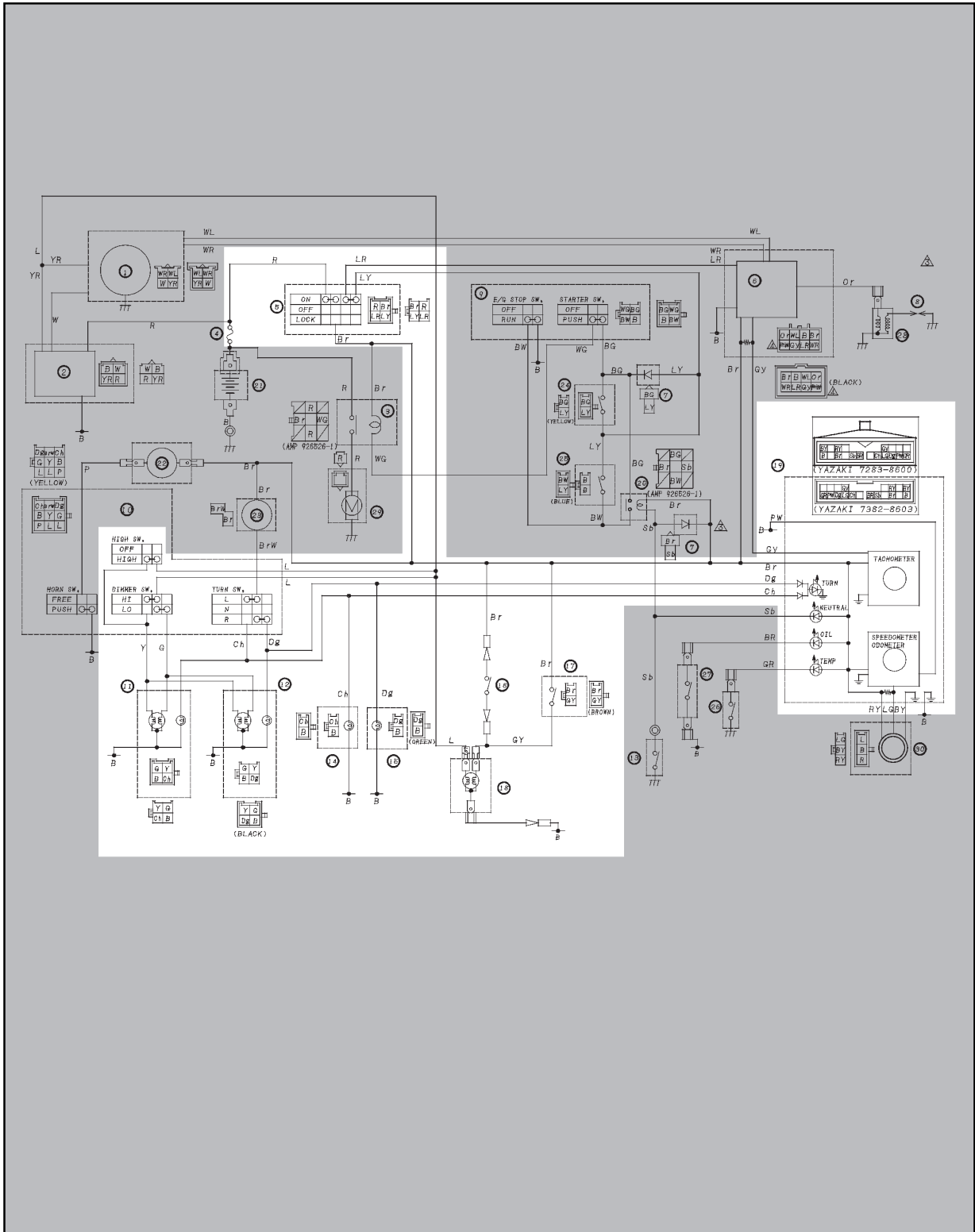

LIGHTING SYSTEM

ELEC

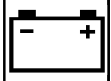

NOTE: _____

For colour codes please see the electrical diagram

- ④ Fuse
- ⑤ Main switch
- ⑪ Front headlight / indicator (LH)
- ⑫ Front headlight / indicator (RH)
- ⑭ Rear indicator (LH)
- ⑮ Rear indicator (RH)
- ⑯ Front brake switch
- ⑰ Rear brake switch
- ⑱ Tail light
- ⑲ Instrument panel

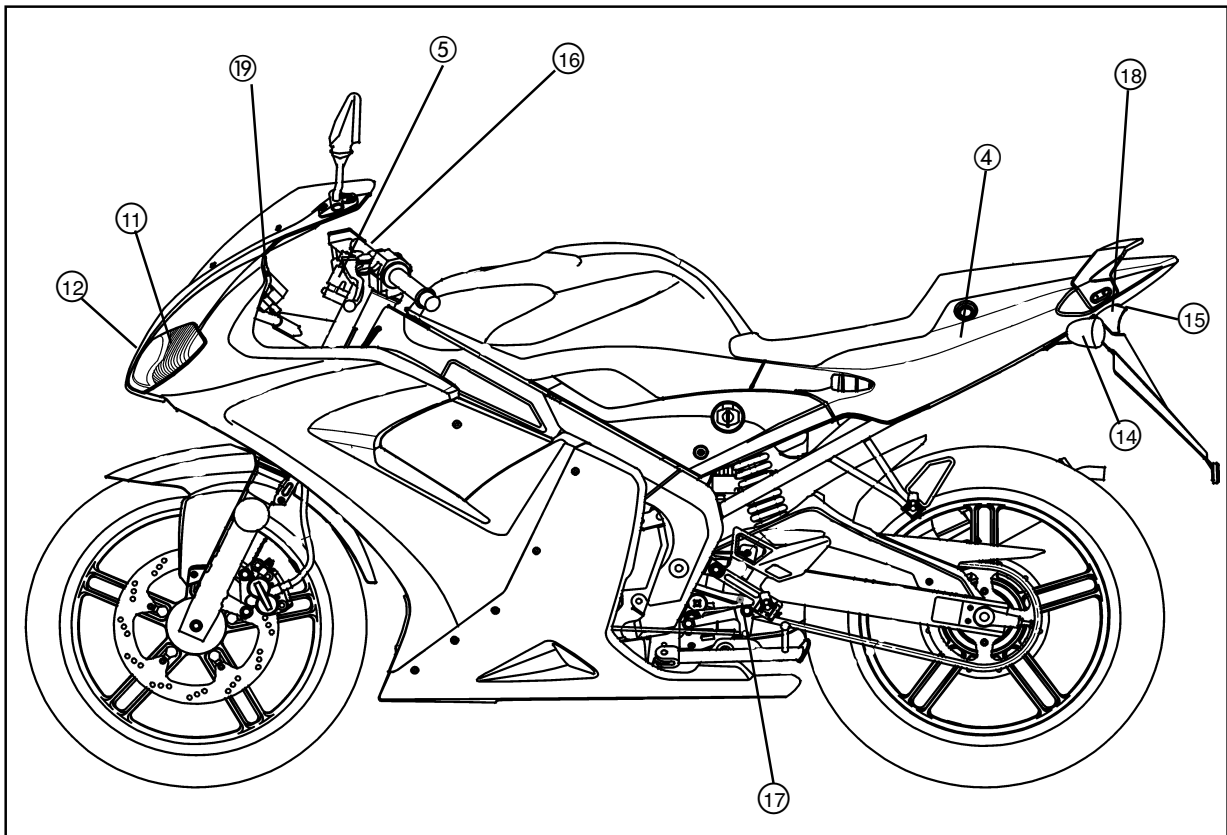

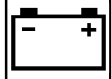

TROUBLESHOOTING

THE HEADLIGHTS, THE SIDE LIGHTS OR THE INSTRUMENT PANEL DO NOT LIGHT UP

Procedure

Check:

1. The fuse
2. The light switch "LIGHTS"
3. The cable connections (lighting system)

NOTE:

- Dismantle the following components before locating the fault.
 - 1) The seat
 - 2) The fuel tank
 - 3) The front bulb holders
- Use the following special tool for solving this fault.



Pocket tester:
90890 - 03112

1. Fuse

- Remove the fuse
- Connect the pocket tester ($\Omega \times 1$) to the fuse.
- Check to see if the continuity is correct in the fuse



CONTINUITY OK

NO CONTINUITY



Replace the fuse.

2. Light switch "LIGHTS"

- Disconnect the coupling of the light switch "LIGHTS" from the connector (yellow).

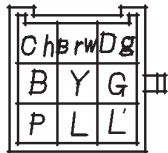

- Check (low beam headlights):
 - Place the switch in LOW position (≡D)
 - Check the continuity between L' and G.
- Check (high beam headlights):
 - Place the switch in HIGH position (≡D)
 - Check the continuity between L' and Y.
- Check (headlight flash):
 - Hold the headlight flash switch down
 - Check the continuity between L and G.

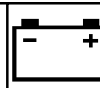

(+) probe of tester → Red / yellow terminal ①
 (-) probe of tester → Blue terminal ③

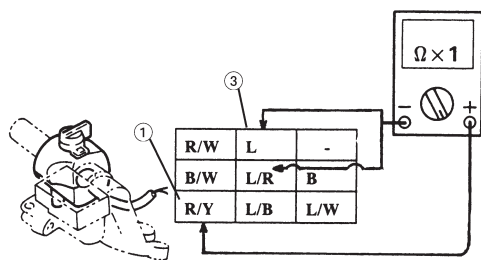

- Place the lights switch “LIGHTS” in positions “POS” and “OFF”, successively.
- Check to see if the continuity is correct in the lights switch.

Position of the switch	In good condition			In bad condition		
Activated	○	X	X	X	X	○
Deactivated	X	○	X	○	X	○
○: Continuity	X: no continuity					

- Check (main beam):

(+) probe of tester → Red / yellow terminal ①
 (-) probe of tester → Blue terminal ②

(+) probe of tester → Red / yellow terminal ①
 (-) probe of tester → Blue/black terminal ③

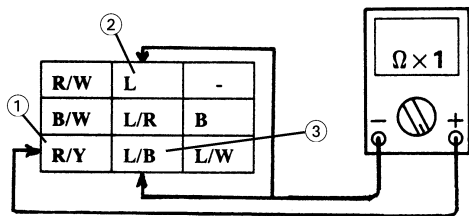

- Place the lights switch “LIGHTS” in positions “ON” and “OFF”, successively.
- Check to see if the continuity is correct in the lights switch.

Position of the switch	In good condition			In bad condition		
Activated	○	X	X	X	X	○
Deactivated	X	○	X	○	X	○
○: Continuity	X: no continuity					

↓ IN GOOD CONDITION
 *

IN BAD CONDITION ↓

Replace the light switch “LIGHTS”

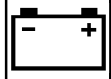

*



3. Cable connections

- Check the cable connections of the whole light system
See the section on "WIRING DIAGRAM"

CONNECTIONS IN BAD CONDITION



Correct these.



CORRECT

See the section on "CHECKING AND TESTING THE LIGHT SYSTEM"

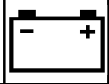

CHECKING AND TESTING THE LIGHT SYSTEM

1. Headlight do not come on

1. Headlight bulb

- Check the continuity between B and Y and between B and G

THERE IS NO CONTINUITY



Replace the headlight bulb.

2. The headlights do not come on

1. Check the bulbs (see previous point).

2. Voltage

- Place the main switch in the ON position
- Place the light change switch in the LOW (LO) beam position
- Connect the pocket tester (DC; 20V) to the headlight coupler

(+) probe of tester → Green terminal ①
 (-) probe of tester → Black terminal ②

MATCHES SPECIFICATIONS

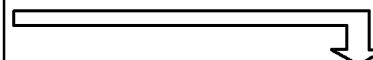

The light system is in good condition.

- Check the headlight voltage



Headlight voltage:
12.0 V



**DOES NOT MATCH
THE SPECIFICATION**

3. Headlight change switch “LIGHTS”

- Disconnect the connectors of the handlebar switches and the connector cables
- Connect the pocket tester ($\Omega \times 1$) to the headlight change switch (“LIGHTS”)

With the headlight change switch “LIGHTS” in position “HI” :

(+) probe of tester → Blue terminal
(-) probe of tester → Yellow terminal

With the headlight change switch “LIGHTS” in position “LO” :

(+) probe of tester → Blue terminal
(-) probe of tester → Green terminal

- Place the headlight change switch “LIGHTS” in positions “HI” high beam “LO” low beam, successively.
- Check to see if the continuity is correct in the switch

Switch position	In good condition	In bad condition		
“HI” high beam	○	X	○	X
“LO” low beam	○	○	X	X
○: Continuity	X: There is no continuity			

IN BAD CONDITION



Replace the handlebar switch

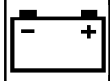

*



4. Cable connections

- Check the wiring connections of the whole lighting system.
See the “ELECTRICAL DIAGRAM” section

3. The tail light does not come on

1. Brake light tail light bulb
<ul style="list-style-type: none"> • Remove the bulb of the brake light tail light • Connect the pocket tester ($\Omega \times 1$) to the bulb of the brake light tail light
<p>(+) probe of tester → Terminal ① (-) probe of tester → Terminal ②</p>
<p>(+) probe of tester → Terminal ① (-) probe of tester → Terminal ③</p>
<ul style="list-style-type: none"> • Check if the continuity is correct in the bulb of the brake light tail light

NO CONTINUITY

Replace the bulb of the brake light tail light.



CONTINUITY OK

2. Voltage
<ul style="list-style-type: none"> • Disconnect the connector of the tail light • Start the engine • Connect the pocket tester (20 VDC) to the tail light connector
<p>(+) probe of tester → Blue terminal ① (-) probe of tester → Black terminal ②</p>

LIGHTING SYSTEM

ELEC

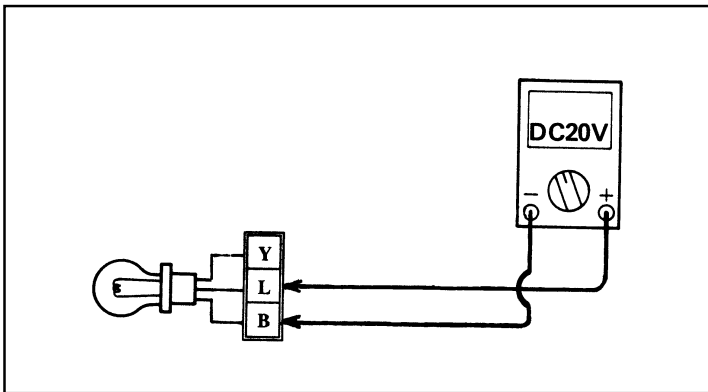
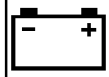

- Check the voltage of the tail light



Voltage of the tail light:
12.0 V

MATCHES THE SPECIFICATION

Replace / service the tail light.

DOES NOT MATCH THE SPECIFICATION

3. Cable connections

Check the connections of the whole light system. See the section on "ELECTRICAL DIAGRAM"

4. The instrument lights do not come on

1. Instrument light bulb

- Remove each bulb from the instrument panel
- Connect the pocket tester ($\Omega \times 1$) to the bulb.

(+) probe of tester → Terminal ①
(-) probe of tester → Terminal ②

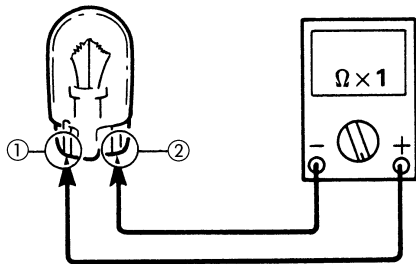

- See if the continuity is correct in the bulb of the instrument panel

CONTINUITY OK

*

NO CONTINUITY

Replace the bulb of the instrument light.

*



2. Voltage

- Disconnect the coupler of the instrument panel
- Place the main switch in the ON position.
- Connect the pocket tester (DC 20V) to the instrument light coupler.

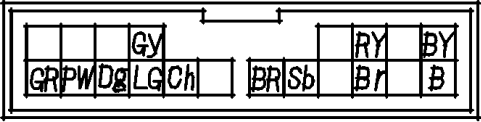

- Check the voltage between Br and B

 **Voltage of the instrument panel:**
12.0 V

DOES NOT MATCH SPECIFICATION



MATCHES SPECIFICATION

Replace the instrument panel.

3. Cable connections

- Check the connections of the whole light system. See the "ELECTRICAL DIAGRAM" section

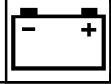

SIGNALING SYSTEM
CIRCUIT DIAGRAM

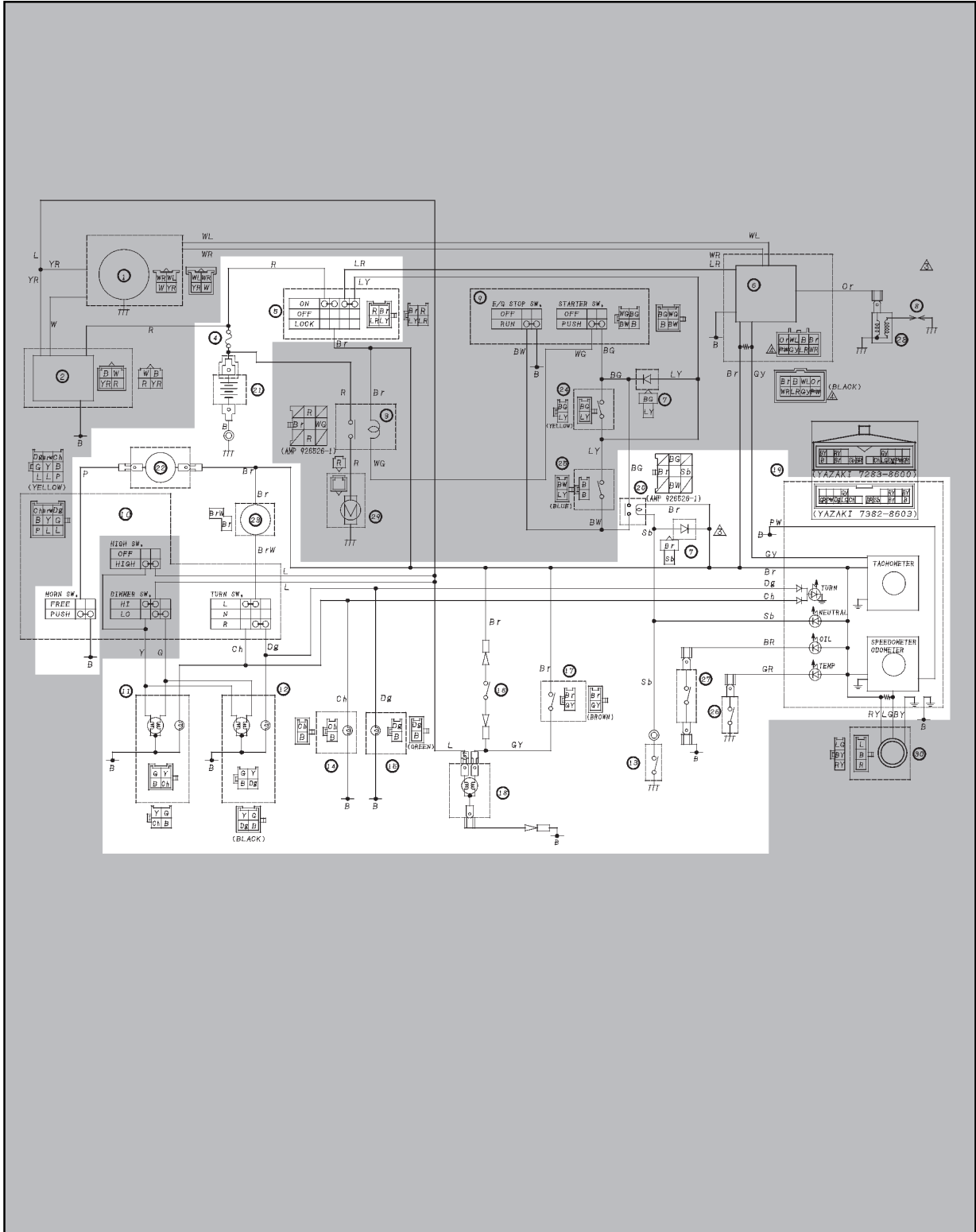

SIGNALING SYSTEM

ELEC

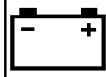

NOTE: _____

For the colour codes please see the electrical diagram

- | | |
|----------------------------------|-----------------------------|
| ④ Fuse | ①⑦ Rear brake switch |
| ⑤ Switch | ①⑧ Tail light / Brake light |
| ⑩ Handlebar switch | ①⑨ Instrument panel |
| ⑪ Front headlight/indicator (LH) | ②⑩ Neutral relay |
| ⑫ Front headlight/indicator (RH) | ②① Battery |
| ⑬ Neutral switch | ②② Horn |
| ⑭ Rear indicator (LH) | ②③ Indicator relay |
| ⑮ Rear indicator (RH) | ②⑥ Thermocontact |
| ⑯ Front brake switch | ②⑦ Oil level switch |

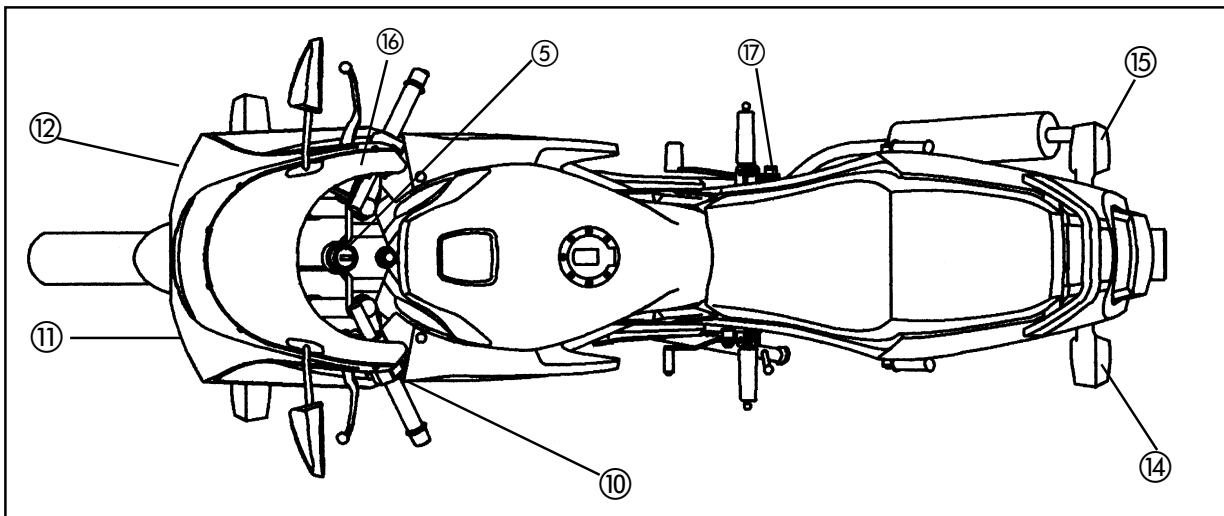
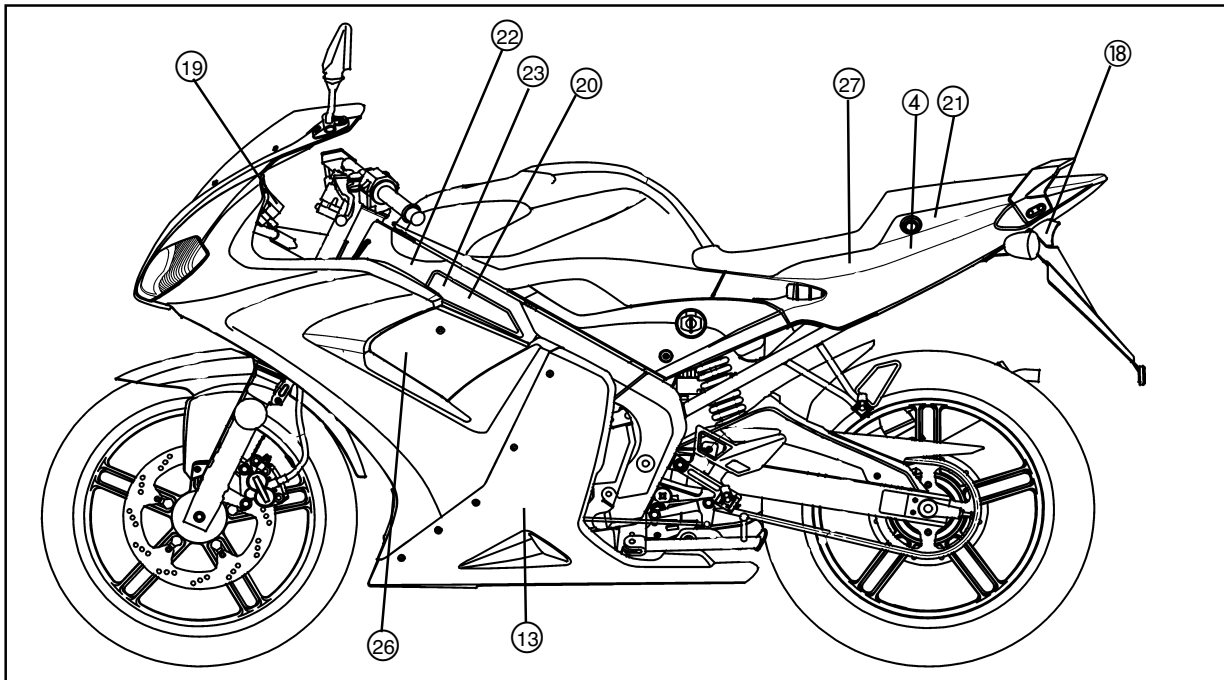

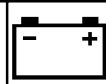

TROUBLESHOOTING

THE INDICATORS, THE BRAKE LIGHT, THE “NEUTRAL” INDICATOR PILOT LIGHT, “TURN” INDICATOR PILOT LIGHT AND THE OIL PRESSURE INDICATOR “OIL” DO NOT COME ON AND THE HORN DOES NOT WORK

Procedure

Check:

1. The fuse
2. The battery
3. Main switch
4. Wiring connections (signalling system)

NOTE:

- Remove the following items before locating the fault.

1 The seat	3 The front fairing
2 The tank	
- To repair these faults use the following special tool:



Pocket tester:
90890 - 03112

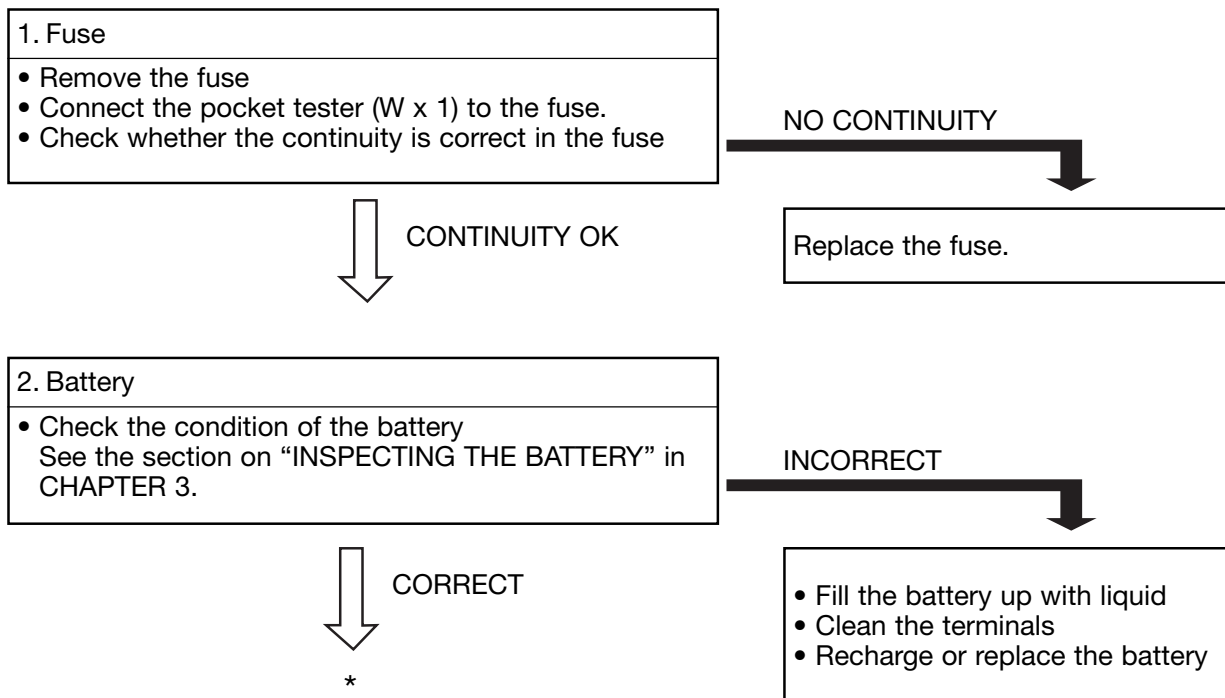

*



3. Main switch

- Disconnect the connector of the main switch
- Connect the pocket tester ($\Omega \times 1$) to the main switch
- Place the main switch in positions "ON" and "OFF" successively.
- Check if the continuity is correct between the red and brown cables only in the "ON" position.

IN BAD CONDITION

Replace the main switch.



IN GOOD CONDITION

4. Cable connections

- Check the connections of the full signalling system
See the section on "WIRING DIAGRAM"

CONNECTIONS INCORRECT

Correct these.



CORRECT

See the section on "CHECKING AND TESTING THE SIGNALLING SYSTEM"



CHECKING AND TESTING THE SIGNALING SYSTEM

1. The indicators do not flash

1. Indicator bulb

- Remove the indicator bulb
- Connect the pocket tester ($\Omega \times 1$) to the bulb

(+) probe of tester → Terminal ①
 (-) probe of tester → Terminal ②

- Check whether the continuity is correct in the head-light bulb

NO CONTINUITY

Replace the indicator bulb.

CONTINUITY OK

2. Bulb holder bush of the indicator

- Place the bulb in the holder
- Disconnect the indicator wires (chocolate and black) or (dark green and black).
- Connect the pocket tester ($\Omega \times 1$) to the indicator cables

To check the right indicator:
 (+) probe of tester → Dark green cable ①
 (-) probe of tester → Black cable ②

To check the left-hand indicator:
 (+) probe of tester → Chocolate cable ①
 (-) probe of tester → Black cable ②

NO CONTINUITY

Check/replace the indicator.



- Check if the continuity is correct in the bulb holder bush of the indicator.

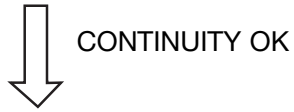

3. Turning switch "TURN"

- Disconnect the large coupler (yellow) from the left-hand switch on the handlebars
- Connect the pocket tester ($\Omega \times 1$) to the turning switch "TURN"

With the "turn" switch in position "☉":
(+) probe of tester → Brown/white terminal
(-) probe of tester → Dark green terminal

With the "turn" switch in position "☾":
(+) probe of tester → Brown/white terminal
(-) probe of tester → Chocolate terminal

- Place the TURN switch in positions "☾" and "☉" successively
- Check if the continuity is correct in the "TURN" switch.

Switch position	In good condition		In bad condition	
	○	×	○	×
"☉" (right)	○	×	○	×
"☾" (left)	○	○	×	×

○: Continuity ×: There is no continuity



Replace the handlebar switch.



*

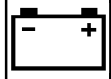

4. Voltage

- Place the main switch in the "ON" position
- Connect the pocket tester (DC, 20 V) to the coupler of the indicator relay.

(+) probe of tester → brown terminal ①
 (-) probe of tester → to ground

- Check the voltage of the indicator relay

Voltage of the indicator relay:
12.0 V

DOES NOT MATCH THE SPECIFICATION



5. Cable connections

Check the connections of the whole light system.
 See the "ELECTRICAL DIAGRAM" section

MATCHES THE SPECIFICATION

Replace the indicator relay

2. The brake light does not come on when the front or rear brake is activated.

1. Tail light/brake light bulb

- Remove the bulb of the tail light / brake light.
- Connect the pocket tester ($\Omega \times 1$) to the bulb

(+) probe of tester → Terminal ①
 (-) probe of tester → Terminal ③

(+) probe of tester → Terminal ②
 (-) probe of tester → Terminal ③

SIGNALING SYSTEM

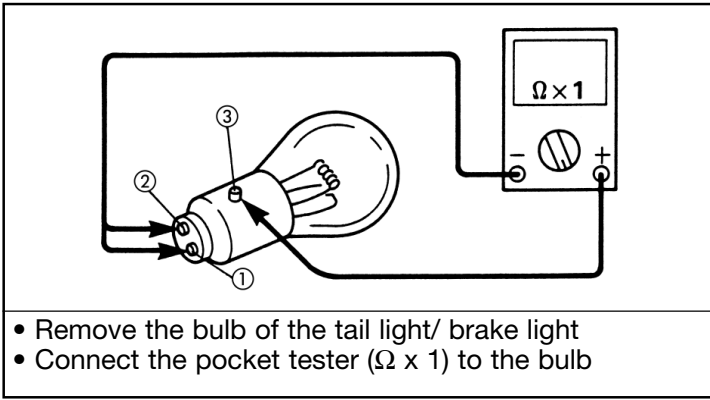

- Remove the bulb of the tail light/ brake light
- Connect the pocket tester ($\Omega \times 1$) to the bulb

CONTINUITY OK

NO CONTINUITY

Replace the tail light / brake light bulb

2. Front brake switch

- Disconnect the coupler of the front switch (brown and green/yellow) of the connector.
- Connect the pocket tester ($\Omega \times 1$) to the cables of the brake switch

(+) probe of tester → Brown terminal ①
 (-) probe of tester → Green/yellow terminal ②

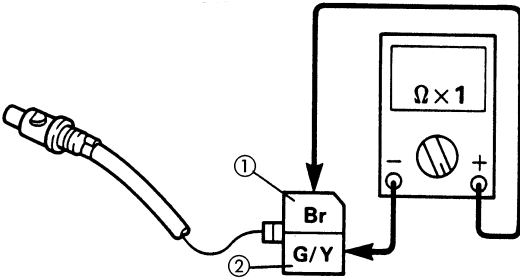

- Check whether the continuity is correct in the brake switch

Switch position	In good condition		In bad condition	
	○	×	○	×
Applying front brake	○	×	×	○
Not applying front b.	×	○	×	○

○: Continuity ×: There is no continuity

IN GOOD CONDITION

IN BAD CONDITION

Replace the front brake switch.

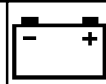

3. Voltage

- Place the main switch in the ON position.
- Apply the front brake
- Connect the pocket tester (DC, 20V) to the front brake switch.

(+) probe of tester → Brown terminal ①
 (-) probe of tester → To ground

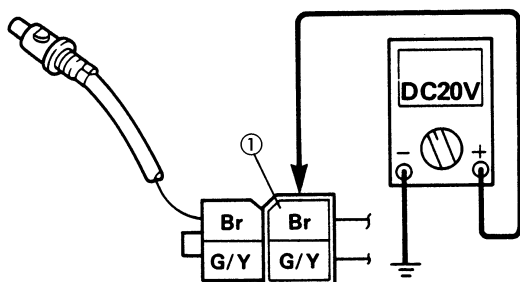

- check the front brake voltage.



Sidelight voltage:
 12.0v

DOES NOT MATCH SPECIFICATION



4. Cable connections

Check the connections of the whole system. See the "ELECTRICAL DIAGRAM" section



MATCHES SPECIFICATION

5. Rear brake switch

- Disconnect the cables of the rear brake switch (brown and green/yellow) of the connector.
- Connect the pocket tester ($\Omega \times 1$) to the cable of the brake switch

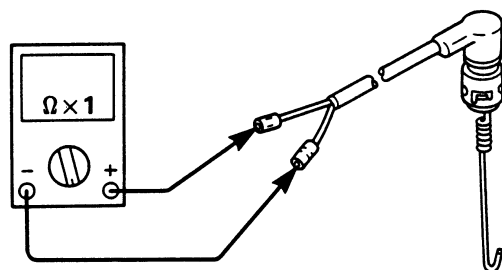

SIGNALING SYSTEM



• Check whether the continuity is correct in the brake switch

Switch position	In good condition	In bad condition		
Applying rear brake	○	X	X	○
Not applying rear b.	X	○	X	○

○: Continuity X : There is no continuity

IN BAD CONDITION

Replace the rear brake switch.

IN GOOD CONDITION

6. Voltage

- Apply the rear brake
- Connect the pocket tester (DC, 20V) to the rear brake switch.

(+) probe of tester → Brown terminal ①
 (-) probe of tester → To ground

• Check/ replace the rear brake light

Rear brake voltage:
12.0v

DOES NOT MATCH SPECIFICATION

7. Cable connections
 Check the connections of the whole system. See the "ELECTRICAL DIAGRAM" section

MATCHES SPECIFICATION

Replace the bulb holder bush of the tail light/brake light

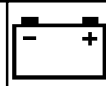

3. The NEUTRAL indicator does not come on

1. Neutral switch
- Disconnect the cable of the neutral switch (light blue) of the connector
 - Connect the pocket tester ($\Omega \times 1$) to the neutral switch.

(+) probe of tester → Light blue terminal ①
 (-) probe of tester → To ground

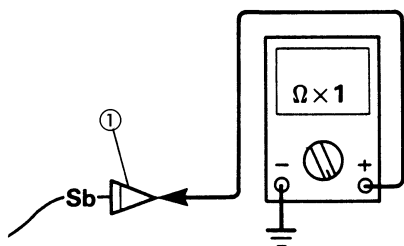

- Put the transmission successively into neutral and then into gear
- Check whether the continuity is correct in the “NEUTRAL” switch

Switch position	In good condition	In bad condition		
		X	X	○
Neutral	○	X	X	○
In gear.	X	○	X	○

○: Continuity X : There is no continuity

IN BAD CONDITION

Replace the neutral switch

IN GOOD CONDITION

*

*



2. Voltage

- Disconnect the instrument panel coupler.
- Place the main switch in the "ON" position
- Connect the pocket tester (DC, 20V) to the instrument panel coupler.

(+) probe of tester → Brown terminal ①
(-) probe of tester → Black terminal ②

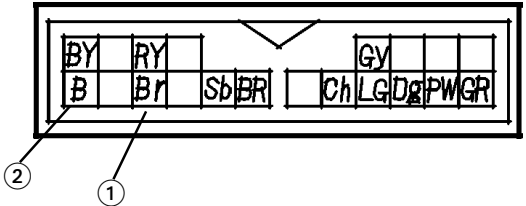

- Check the voltage of the front brake.

 **Instrument panel voltage:**
12.0 V

DOES NOT MATCH SPECIFICATION



3. Cable connections

Check the connections of the whole system.
 See the "ELECTRICAL DIAGRAM" section



MATCHES SPECIFICATION

Change the instrument panel.

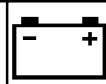

4. The turning indicator pilot light “TURN” does not come on

1. Turning switch “TURN”

- Disconnect the large coupler (yellow) from the left-hand switch on the handlebars.
- Connect the pocket tester ($\Omega \times 1$) to the turning switch “TURN”

With the TURN switch in position “ ϕ ”:

(+) probe of tester → **Brown/white terminal**
 (-) probe of tester → **Dark green terminal**

With the TURN switch in position “ \rightarrow ”:

(+) probe of tester → **Brown/white terminal**
 (-) probe of tester → **Chocolate terminal**

- Place the “TURN” switch in positions “ ϕ ” and “ \leftarrow ” successively.
- Check if the continuity is correct in the TURN switch

Switch position	In good condition	In bad condition		
“ ϕ ” (right)	○	X	○	X
“ \leftarrow ” (left)	○	○	X	X

○: Continuity **X**: No continuity



IN BAD CONDITION

↓
IN GOOD CONDITION
*

Replace the handlebar switch.

*

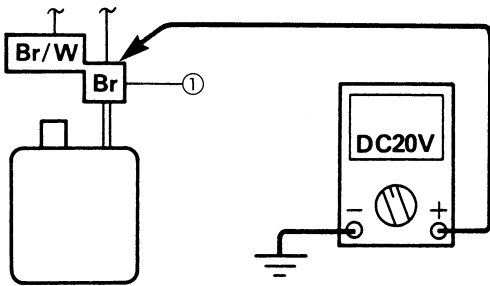

2. Voltage	
<ul style="list-style-type: none"> Place the main switch in the "ON" position Connect the pocket tester 	
<p>(+) probe of tester → Brown terminal ① (-) probe of tester → Ground</p>	
	
<ul style="list-style-type: none"> Check the voltage of the front brake. 	
	<p>Indicator voltage: 12.0 V</p>

DOES NOT MATCH SPECIFICATION



3. Cable connections
<p>Check the connections of the whole system. See the "ELECTRICAL DIAGRAM" section</p>



MATCHES SPECIFICATION

4. Indicator relay	
<ul style="list-style-type: none"> Line up the relay 	
<p>(+) probe of tester → Brown terminal (-) probe of tester → Brown/white terminal</p>	
<p>The indicator can be heard to operate</p>	

DOES NOT MATCH SPECIFICATION



<p>Replace the indicator relay.</p>



MATCHES SPECIFICATION

<p>Change the instrument panel</p>

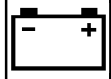

5. The oil level indicator light does not come on

<p>1. Oil level switch</p> <ul style="list-style-type: none"> Remove the oil level switch from the oil tank Disconnect the switch coupler (black, black/red) from the connector. Connect the pocket tester ($\Omega \times 1$) to the oil level switch.
<p>Check 1</p> <p>(+) probe of tester → Black/red terminal</p> <p>(-) probe of tester → Black terminal</p>
<ul style="list-style-type: none"> Check if the continuity is correct in the oil level switch

NO CONTINUITY



Replace the oil level switch.



CONTINUITY OK

<p>2. Voltage</p> <ul style="list-style-type: none"> Disconnect the instrument panel coupler. Place the main switch in the "ON" position Connect the pocket tester (DC, 20V) to the instrument panel coupler.
<p>(+) probe of tester → Brown terminal ①</p> <p>(-) probe of tester → Black terminal ②</p>
<ul style="list-style-type: none"> Check the voltage of the front brake.
<div style="display: flex; align-items: center;"> <p>Instrument panel voltage: 12.0 V</p> </div>

DOES NOT MATCH SPECIFICATION



3. Cable connections

Check the connections of the whole system.
See the "ELECTRICAL DIAGRAM" section



MATCHES SPECIFICATION

Change the instrument panel.

6. The horn does not sound when the HORN switch is pressed

1. HORN switch

- Disconnect the handlebar switch connector from the connector
- Connect the pocket tester ($\Omega \times 1$) to the HORN switch.

(+) probe of tester → Pink terminal
(-) probe of tester → Black terminal

- Check if the continuity is correct in the HORN switch

Switch position	In good condition	In bad condition		
Horn switch on	○	X	X	○
Horn switch not on	X	○	X	○

○: Continuity **X**: No continuity

↓ CONTINUITY OK

↓ IN BAD CONDITION

Replace the handlebar switch.

2. Voltage

- Connect the pocket tester (DC, 20V) to the horn connector.

(+) probe of tester → Brown terminal ①
(-) probe of tester → To ground

- Check the voltage of the horn.

Horn voltage:
12.0 V

↓ MATCHES SPECIFICATION

↓ DOES NOT MATCH SPECIFICATION

3. Cable connections

Check the connections of the whole system.
 See the "ELECTRICAL DIAGRAM" section

*

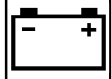

*



4. Horn

- Disconnect the pink cable from the horn terminal
- Connect a bridge cable ① to the horn terminal and lead this to ground.

THE HORN SOUNDS

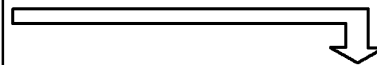

The horn is in good condition



THE HORN DOES NOT SOUND

5. Voltage

- Connect the pocket tester (DC, 20V) to the pink horn terminal.

(+) probe of tester → Pink terminal ①
 (-) probe of tester → To ground

- Check the voltage of the pink terminal.

Horn voltage:
12.0 V

DOES NOT MATCH SPECIFICATION



Replace the horn.



MATCHES SPECIFICATION

Adjust or replace the horn.

COOLING SYSTEM

ELEC

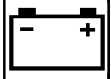

NOTE: _____

For the colour codes please see the electrical diagram

- ④ Fuse
- ⑤ Main switch
- ⑱ Instrument panel
- ⑳ Battery
- ㉔ Thermocontact

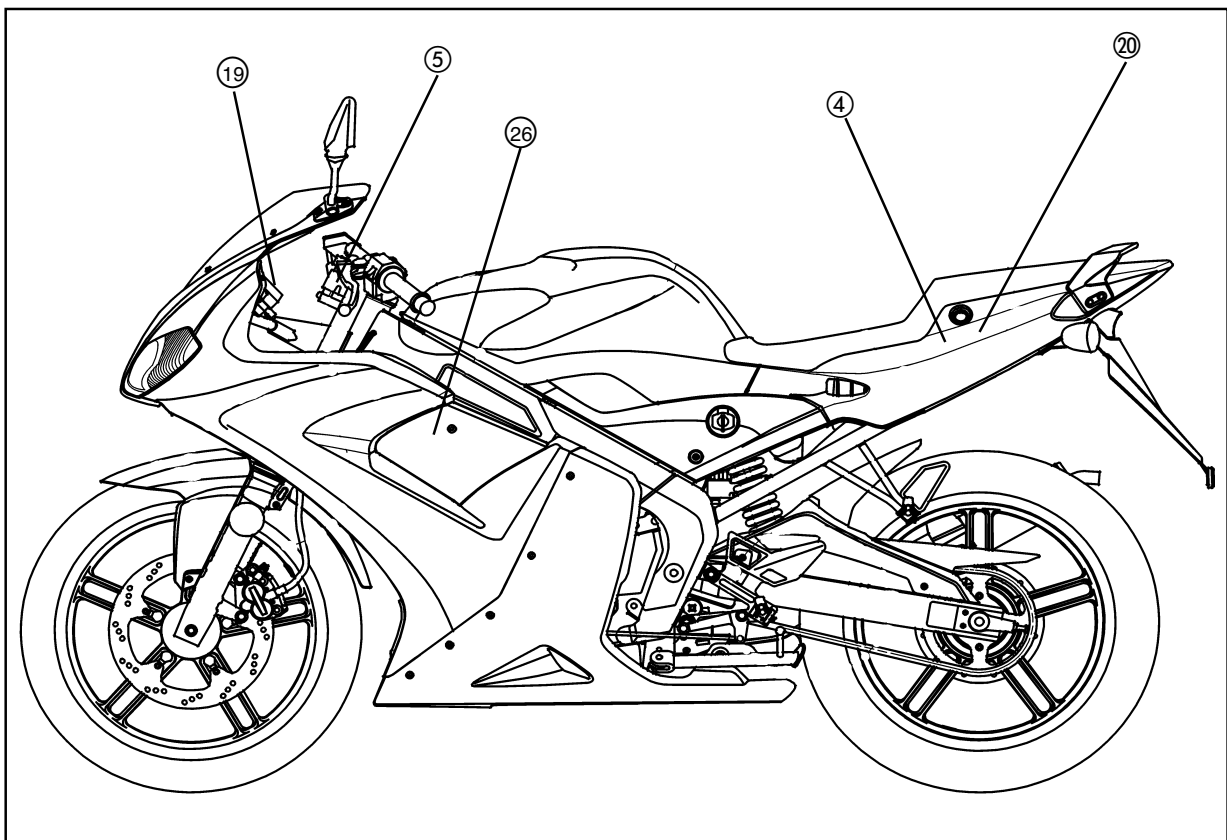

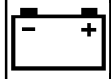

TROUBLESHOOTING

THE TEMPERATURE LIGHT DOES NOT COME ON WHEN THE ENGINE IS HOT

Procedure

Check:

- 1. The seat
- 2. The tank
- 3. The front fairing

NOTE:

- Remove the following items before locating the fault.
 - 1) The seat
 - 2) The side fairing (left)
 - 3) The side fairing (right)
 - 4) The headlight assembly
- To solve this breakdown, use the following special tool:



Pocket tester:
90890 - 03112

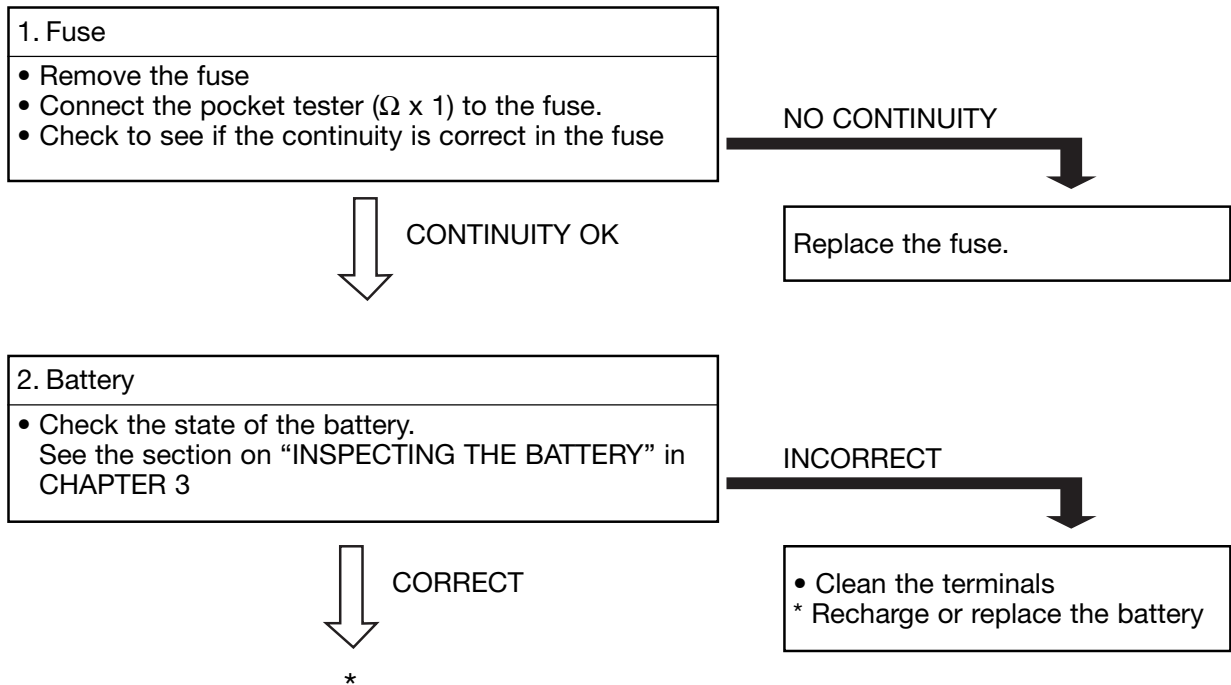

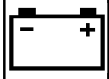

*



3. Main switch

- Disconnect the coupler from the main switch
- Connect the pocket tester ($\Omega \times 1$) to the main switch

(+) probe of tester → Red terminal ①
 (-) probe of tester → Brown terminal ②

- Put the main switch into the “ON” and “OFF” positions alternatively.
- Check to see if there is continuity in the main switch.

Switch position	In good condition	In bad condition		
ON	○	X	X	○
OFF	X	○	X	○

○: Continuity X : No continuity



IN GOOD CONDITION

4. Temperature indicator

- Disconnect the thermosensor cable (green/red) ① from the connector
- Connect the cable to ground (chassis) with a bridge cable
- Place the main switch in ON position
- Check whether the temperature indicator comes on



CORRECT

IN BAD CONDITION

Replace the main switch.

INCORRECT

5. Cable connections

- Check the connections of the whole system. See the “ELECTRICAL DIAGRAM” section



CORRECT

Replace the instrument panel.

COOLING SYSTEM

ELEC

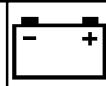

6. Thermosensor

- Remove the thermosensor from its housing.
- Connect the pocket tester ($\Omega \times 1$) to the thermosensor
- ①
- Submerge the thermosensor in water ②
- Measure the resistances.
- Take note of the temperatures while the water is heated up with the thermosensor in 3.

Up to 115°C
No continuity

From 115°C
Continuity

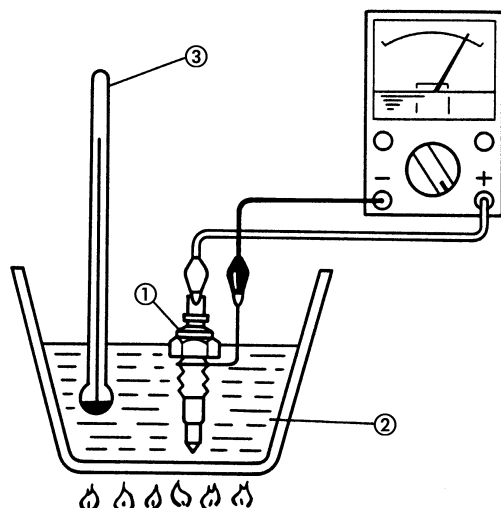

↓
THE RESISTANCES
MATCH
SPECIFICATIONS

7. Cable connections

- Check the connections of the whole cooling system
See the "ELECTRICAL DIAGRAM" section

⚠ WARNING

Handle the thermostat with special care. Never let this receive any impacts or fall. If it does accidentally fall, replace it.

UNDER 115 °C OVER 115 °C

Replace the thermosensor.

CAUTION

After replacing the thermosensor, check the level of the coolant liquid in the radiator and see if there are any leaks.

BAD CONNECTIONS

Correct.

ELECTRICAL DIAGRAM TZR50

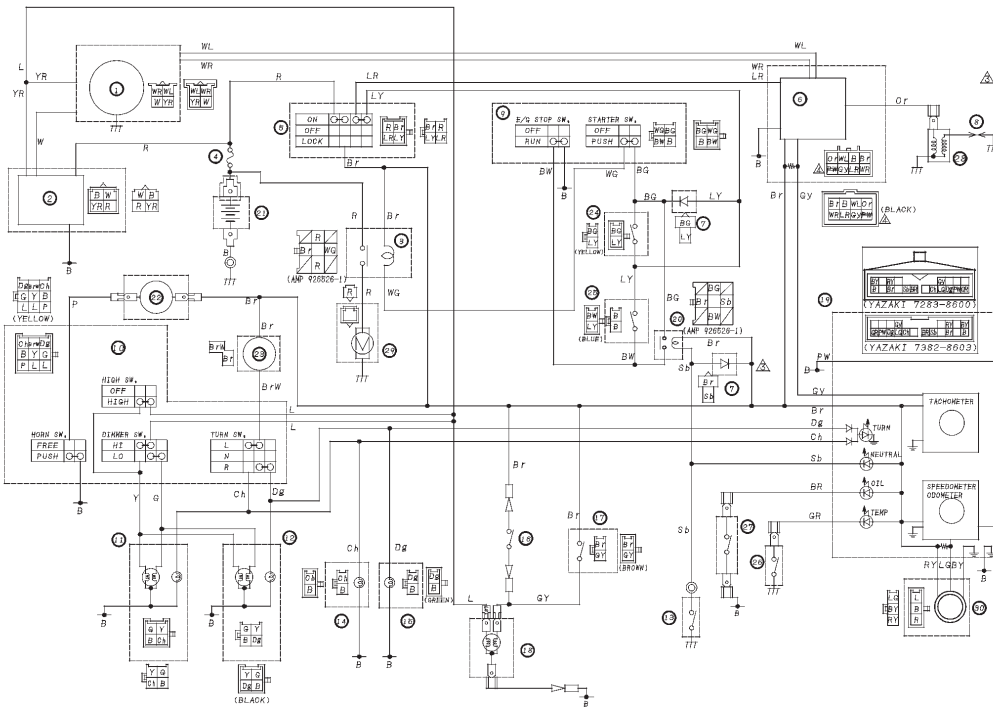

COLOUR CODE

B	Black	B/R	Black/red
R	Red	B/W	Black/white
L	Blue	G/R	Green/red
G	Green	G/Y	Green/yellow
O	Orange	Br/W	Brown/white
Y	Yellow	W/R	White/red
P	Pink	W/B	White/black
Br	Brown	W/G	White/green
Ch	Chocolate	Y/L	Yellow/blue
Sb	Sky blue	Y/R	Yellow/red
Dg	Dark green	L/B	Blue/Black
W	White	L/R	Blue/red
B/Y	Black/brown	L/W	Blue/white
B/Y	Black/yellow	L/Y	Blue/yellow

- ① Magnetic flywheel
- ② Regulator/ rectifier
- ③ Starter relay
- ④ Fuse
- ⑤ Main switch
- ⑥ CDI
- ⑦ Diode x 2
- ⑧ Spark plug
- ⑨ Handlebar switch (RH)
- ⑩ Handlebar switch (LH)
- ⑪ Front headlight/Flasher ó turn signal indicator light (LH)
- ⑫ Front headlight/Flasher ó turn signal indicator right (RH)
- ⑬ Neutral switch
- ⑭ Rear Flasher (LH)
- ⑮ Rear Flasher (RH)
- ⑯ Front brake switch
- ⑰ Rear brake switch
- ⑱ Tail light
- ⑲ Instrument panel
- ⑳ Neutral relay
- ㉑ Battery
- ㉒ Horn
- ㉓ Flasher relay ó turn signal indicator light
- ㉔ Clutch switch
- ㉕ Side stand switch
- ㉖ Thermocontact
- ㉗ Oil level switch
- ㉘ Coil
- ㉙ Starter motor
- ㉚ Speedometer sensor