

# YAMAHA AT1-C/MX

[www.legends-yamaha-enduros.com](http://www.legends-yamaha-enduros.com)



[www.legends-yamaha-enduros.com](http://www.legends-yamaha-enduros.com)

## SERVICE MANUAL

**\*\*\*\*\* NOTICE \*\*\*\*\***

This manual has been written by Yamaha Motor Company for use by Authorized Yamaha Dealers and their qualified mechanics. In light of this purpose it has been assumed that certain basic mechanical precepts and procedures inherent to our product are already known and understood by the reader.

Without such basic knowledge, repairs or service to this model may render the machine unsafe, and for this reason we must advise that all repairs and/or service be performed by an Authorized Yamaha dealer who is in possession of the requisite basic product knowledge.

Other information is produced by the U.S. distributor, Yamaha International Corporation, and is necessary to provide total technical coverage regarding the product.

**\*\*\*\*\***

The Research, Engineering, and Service Departments of Yamaha are continually striving to further improve all models manufactured by the company. Modifications are therefore inevitable and changes in specifications or procedures will be forwarded to all Authorized Yamaha Dealers and will, where applicable, appear in future editions of this manual.

**\*\*\*\*\***

[www.legends-yamaha-enduros.com](http://www.legends-yamaha-enduros.com)

**YAMAHA AT1-C(MX) SERVICE MANUAL**

1st Edition

JULY 1970

SERVICE DEPARTMENT  
YAMAHA MOTOR COMPANY  
HAMAMATSU, JAPAN

---

## FOREWORD

The Yamaha 125 AT1-C is originally designed for off-the-road riding as a trials machine or a scrambler, but it is also built to excel in high speed performance over the road or highways.

Not only that, it is equipped with the safety parts required for a street touring model. Another attractive feature is its ready convertibility to a high-power motocrosser with tuning parts. (The AT1-MX is equipped with the GYT parts as standard equipment.)

This manual is offered so that all Yamaha dealers and service engineers will become familiar with the technical information and service instructions essential to the AT1-C.

[www.legends-yamaha-enduros.com](http://www.legends-yamaha-enduros.com)

**YAMAHA MOTOR CO., LTD.**  
**SERVICE DIVISION**

---

## Contents

<b>Chapter I General</b> .....	5
I – 1 Profile .....	5
I – 2 Features .....	6
I – 3 Specifications .....	8
I – 4 Performance Curves.....	10
I – 5 Tools and Instruments for Shop Service .....	12
<b>Chapter II Yamaha Autolube</b> .....	14
II – 1 What is Yamaha Autolube? .....	14
II – 2 Features of Yamaha Autolube .....	14
II – 3 Handling the Oil Pump .....	15
<b>Chapter III 5-Port Cylinder Induction System</b> .....	20
III– 1 Description of 5-Port Cylinder Induction System .....	20
III– 2 Construction and Features Design of the 5-port Induction System .....	20
<b>Chapter IV Engine</b> .....	22
IV– 1 Engine Removal .....	22
IV– 2 Cylinder Head.....	26
IV– 3 Cylinder .....	27
IV– 4 Piston Pin .....	29
IV– 5 Piston Ring.....	30
IV– 6 Piston.....	32
IV-7-1 Flywheel Magneto .....	33
IV-7-2 Starter Dynamo .....	34
IV– 8 Crankcase Cover (R.H.).....	36
IV– 9 Clutch.....	38
IV–10 Primary Drive Gear.....	43
IV–11 Kick Starter Mechanism .....	44
IV–12 Shift Mechanism.....	47
IV–13 Drive Sprocket .....	49

---

IV-14 Crank Case .....	51
IV-15 Transmission Assembly .....	52
IV-16 Crank Shaft.....	56
IV-17 Bearings and Oil Seals .....	59
IV-18 Carburetor .....	60
IV-19 Air Cleaner.....	64
<b>Chapter V Chassis .....</b>	<b>65</b>
V- 1 Front Wheel.....	65
V- 2 Rear Wheel.....	70
V- 3 Rear Wheel Sprocket .....	75
V- 4 Tires and Tubes .....	76
V- 5 Front Forks.....	76
V- 6 Rear Shocks .....	80
V- 7 Gas Tank.....	81
V- 8 Rear Swing Arm .....	83
V- 9 Steering Head.....	85
V-10 Oil Tank, Battery Box and Tool Box.....	86
V-11 Frame.....	86
V-12 Handlebars .....	86
V-13 Miscellaneous .....	86
<b>Chapter VI Electrical System for AT1-MX .....</b>	<b>87</b>
VI- 1 Description.....	87
VI- 2 Ignition System—Function and Service.....	88
VI- 3 Ignition Timing .....	88
VI- 4 Ignition Coil .....	89
VI- 5 Condenser.....	89
VI- 6 Spark Plug .....	90

---

Chapter VII Electrical System for AT1-C ..... 92

    VII- 1 Description..... 92

    VII- 2 Table of Component parts..... 92

    VII- 3 Main Components ..... 92

    VII- 4 Connection Diagram ..... 93

    VII- 5 Starter Dynamo ..... 93

    VII- 6 Regulator ..... 102

    VII- 7 Ignition Coil ..... 104

Chapter VIII Conversion of the YAMAHA AT1-C for racing ..... 106

    VIII- 1 Engine Tune-up ..... 106

    VIII- 2 Modification of the chassis ..... 109

    VIII- 3 Service Data ( AT1-MX Specifications)..... 111

    VIII- 4 Change in Specifications ..... 111

    VIII- 5 Miscellaneous Notes ..... 112

[www.legends-yamaha-enduros.com](http://www.legends-yamaha-enduros.com)

---

## Chapter I General

### I-1 Profile

AT1-C



AT1-MX



---

## I-2 Features of Yamaha 125AT1-C

### 1. High-performance Single Cylinder Engine

The Yamaha 125 AT1-C utilizes a powerful two-stroke 123 cc engine. The new five-port cylinder, which is another Yamaha technical development, greatly improves engine efficiency and is responsible for high power output throughout a broad RPM range.

### 2. Highly-dependable Yamaha Autolube

Yamaha Autolube provides superior engine lubrication that extends the life of the engine.

### 3. Easy Starting

The engine can be started by simply disengaging the clutch and kicking the kick pedal without shifting gears back to neutral. This is a valuable convenience to the rider. The AT1-C also has an electric starter dynamo for easier starting. The AT1-MX is equipped with a magneto. To start the engine, kick the kick pedal.

### 4. Powerful Brakes

Patented waterproof, dustproof brake drums provide safe, fade-free braking on wet or dusty roads.

### 5. Adjustable Rear Cushion

The rear cushions are adjustable for three positions. The rider can adjust spring tension to compensate for varying weight, speed, and road conditions.

### 6. Front Fork Design

[www.legends-yamaha-enduros.com](http://www.legends-yamaha-enduros.com)

The Yamaha 125 AT1-C employs a front fork design well-known for its strength and superior handling characteristics. Its use assures the rider of the ultimate suspension for even the roughest terrain. The AT1-MX also employs an oil damper for better driving stability.



---

## **7. Speedometer and Tachometer**

Both speedometer and tachometer are standard equipment. Individual units are separately mounted for maximum visibility. An additional feature of the speedometer is an odometer which can be reset to zero for trip or enduro purposes.

## **8. Tires**

The YAMAHA AT1-C is fitted with Dunlop Trials Universal as standard equipment. This particular tread is one of the most versatile available. It gives maximum trail traction and yet is compatible with road usage.

## **9. Carburetor Starter Feature**

Yamaha's starter feature is already well-known for its easy starting. Equipped with this unique carburetor, the Yamaha AT1-C is quick starting under all conditions.

## **10. GYT (Genuine Yamaha Tuning) Kit**

The AT1-MX is furnished with the GYT kit so that it can be used as a fully-equipped motocrosser.

[www.legends-yamaha-enduros.com](http://www.legends-yamaha-enduros.com)

### I-3 Specifications & Performance AT1-C & AT1-MX

Model:	YAMAHA 125 AT1-C	YAMAHA 125 AT1-MX
<b>Dimensions:</b> Overall length Overall width Overall height Wheelbase Min. ground clearance	77.2 in. 35.8 in. 42.9 in. 50.6 in. 8.9 in.	76.4 in. 35.8 in. 43.1 in. 50.8 in. 9.1 in.
<b>Weight:</b> Net Gross <b>Performance:</b> Max. speed Fuel consumption (on paved level roads) Climbing ability Min. turning radius Braking distance	218 lbs. 234 lbs. 60 mph plus 141.1 mpg at 25 mph 30 degrees 75.1 in. 58.3 ft at 31 mph	202 lbs. 218 lbs. 70 mph plus 74.8 in. 58.3 ft at 31 mph
<b>Engine:</b> Model Type Lubricating system  Cylinder Displacement Bore × Stroke Compression ratio Max. power Max. torque Starting system Ignition system Ignition timing	AT1 2 stroke, gasoline Separate lubrication (YAMAHA Autolube) Single, forward inclined, 5port 7.51 cu. in. (123 c.c.) 2.205 in. × 1.969 in. (56 mm × 50 mm) 7.1 : 1 11.5 BHP/7,500 r.p.m 8.5 ft-lb/6,000 r.p.m Electric & kick starter Battery ignition <small>enduros.com</small> 1.8 mm. B.T.D.C	Same as left Same as left YAMAHA Autolube & Gas/oil mixture Same as left Same as left Same as left 8.0 : 1 18 BHP/8,500 r.p.m 11.4 ft-lb/7,500 r.p.m Kick starter Magneto ignition 2.0 mm. B.T.D.C.
<b>Carburetor:</b> Type M. J. J. N.	VM24SH #150 4D3-3 Stages	VM26SH #190 4F15-2 Stages
<b>Air cleaner:</b>	Wet, foam rubber	Same as left
<b>Transmission:</b> Clutch Primary reduction system Primary reduction ratio	Wet, multiple-disk Gear 3.894 (74/19)	Same as left Same as left Same as left

<b>Gear box:</b> Type Reduction ratio 1st 2nd 3rd 4th 5th Secondary reduction system Secondary reduction ratio	Constant mesh, 5-speed forward 3.182 (35/11) 2.000 (30/15) 1.368 (26/19) 1.000 (23/23) 0.800 (20/25) Chain 3.214 (45/14)	Same as left 2.833 (34/12) 1.875 (30/16) 1.368 (26/19) 1.091 (24/22) 0.957 (22/23) Same as left 3.000 (45/15)
<b>Chassis:</b> Frame Suspension system, front Suspension system, rear Cushion system, front Cushion system, rear	Tubular-Double loop Telescopic fork Swinging, arm Coil spring, oil damper Coil spring, oil damper	Same as left Same as left Same as left Same as left Same as left
<b>Steering system:</b> Steering angle Caster Trail	49° both right and left 60.5° 4.72 in. (120 mm)	Same as left Same as left 4.84 in. (123 mm)
<b>Braking system:</b> Type of brake Operation system, front Operation system, rear	Internal expansion Right hand operation Right foot operation	Same as left Same as left Same as left
<b>Tire size:</b> Front Rear	3.00-18-4PR 3.25-18-4PR	3.25-18-4PR 3.50-18-4PR
<b>Dynamo:</b> Model Manufacturer	GS114 HITACHI Ltd.	F130 Same as left
<b>Battery:</b> Model Manufacturer Capacity	12N7-3B (BRT3-12E) FURUKAWA Battery. 12V 7AH	
<b>Lighting:</b> Head light Tail light Stop light Meter light Flasher light High beam indicator light	12V 25WD 12V 7W 12V 23W 12V 3W×2 12V 8W×2 12V 1.5W	
<b>Tanks:</b> Gasoline tank capacity Oil tank capacity	1.9 US gals. 1.3 US	1.9 US gals. 1.3 US qts.

# I-4 PERFORMANCE CURVES

## 125 AT1-C ENGINE PERFORMANCE CURVES

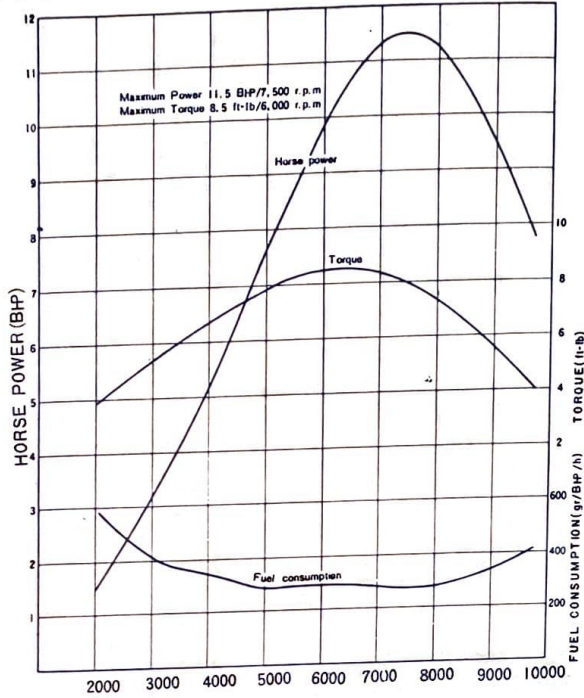

## 125AT1-C DRIVING PERFORMANCE CURVES

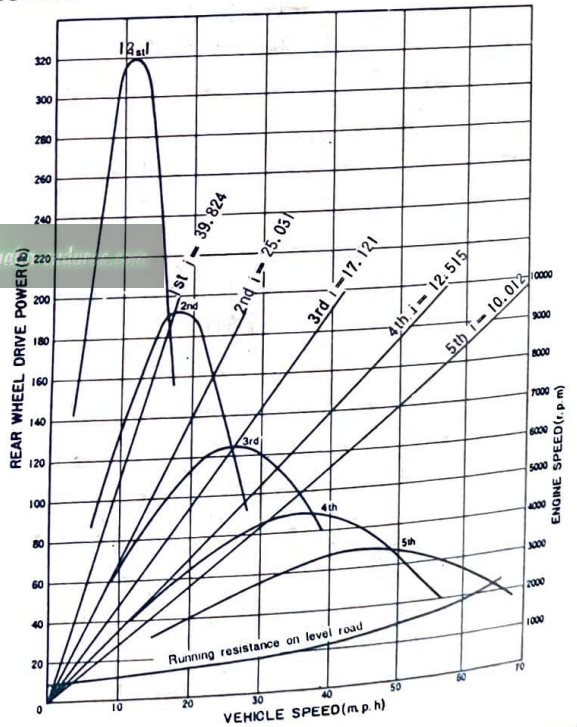

## 125 AT1-MX ENGINE PERFORMANCE CURVES

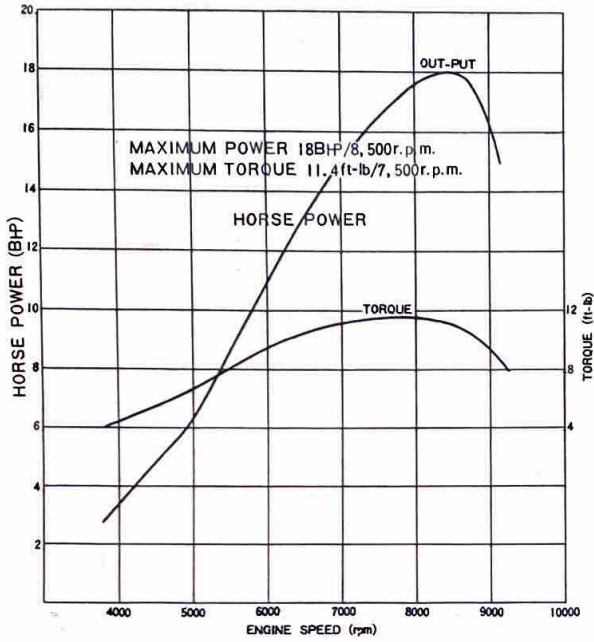

## 125AT1-MX DRIVING PERFORMANCE CURVES

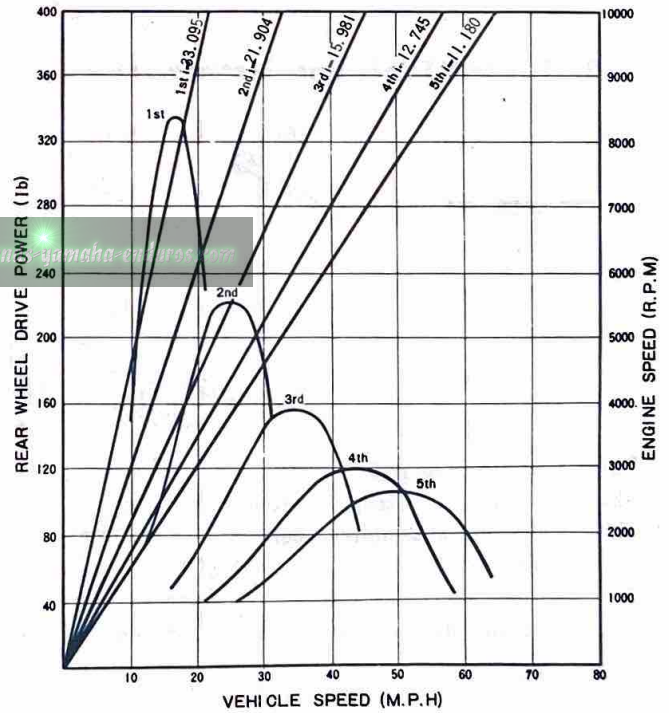

## I-5 Tools and Instruments for Shop Service

The following tools and instruments are required to service the AT1-C & AT1-MX

### 1. General Tools

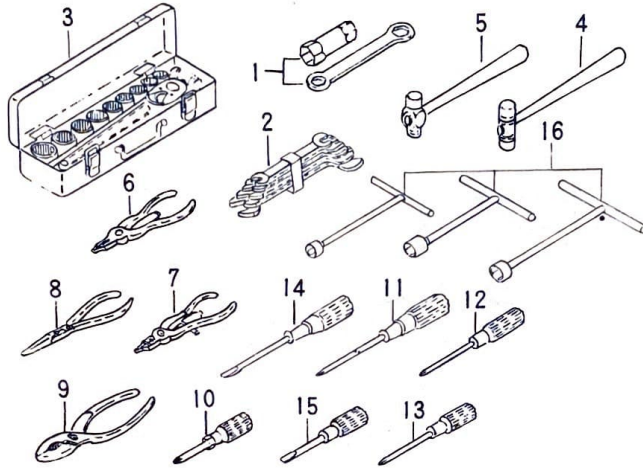

- |                             |                                   |                                   |
|-----------------------------|-----------------------------------|-----------------------------------|
| 1) Plug wrench 23×29 mm.    | 7) Circlip pliers (TR type)       | 13) Phillips-head screwdriver (S) |
| 2) A set of wrenches        | 8) Needle nose pliers             | 14) Slot-head screwdriver (M)     |
| 3) A set of socket wrenches | 9) Pliers                         | 15) Slot-head screwdriver (S)     |
| 4) Plastic tip hammer       | 10) Phillips-head screwdriver     | 16) T-handle socket wrench        |
| 5) Steel hammer             | 11) Phillips-head screwdriver (L) |                                   |
| 6) Circlip pliers (ST type) | 12) Phillips-head screwdriver (M) |                                   |

Fig. I-5-1

### 2. Special Tools and instruments

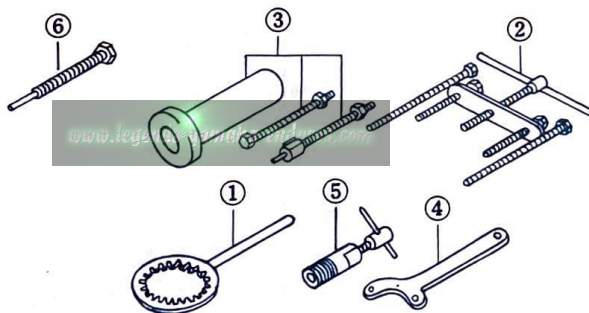

- |   |                                     |
|---|-------------------------------------|
| 1) Clutch holding tool                    | 5) Flywheel magneto puller (AT1-MX) |
| 2) Crankcase disassembling tool           | 6) Armature puller bolt (AT1-C)     |
| 3) Crankshaft assembling tool             |                                     |
| 4) Flywheel magneto holding tool (AT1-MX) |                                     |

In addition, an electro-tester, tachometer (engine rpm meter) hydrometer, etc. will be furnished.

Fig. I-5-2

---

### 3. Other Materials

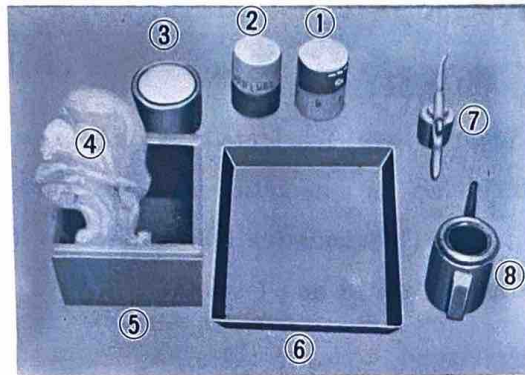

- |                        |                                   |
|------------------------|-----------------------------------|
| 1) Grease              | 5) Overhauling stand (Wooden box) |
| 2) Autolube oil        | 6) Parts tray                     |
| 3) Yamaha Bond (No. 5) | 7) Oiler                          |
| 4) Wiping material     | 8) Oil jug                        |

Fig. I-5-3

The use of a wooden box as shown in the above photo will facilitate engine service and overhaul. Consumable parts (such as gaskets) and replacement parts must also be on hand.

## Chapter II. YAMAHA Autolube (Automatic, Separate Lubricating System)

### II-1. What is YAMAHA Autolube?

Conventional 2-stroke engines are lubricated by oil premixed in gasoline, but YAMAHA's Autolube furnishes an automatic, separate lubrication system. That is, the oil in a separate oil tank is automatically regulated by the oil pump and fed to the engine according to engine speed and load.

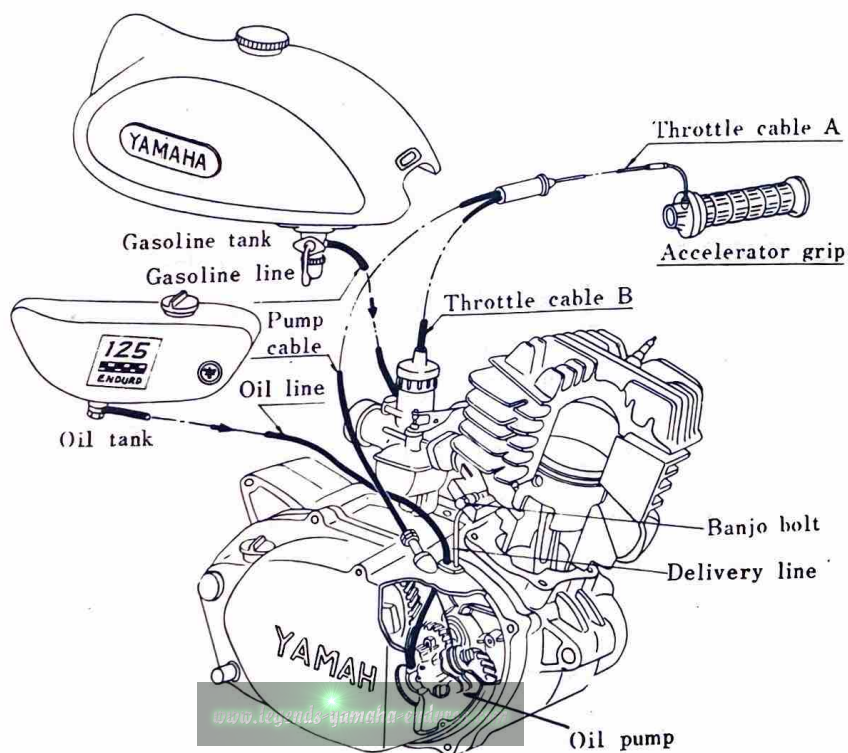

Fig. II-1-1

### II-2. Features of YAMAHA Autolube

The oil pump is driven by the engine through a reduction gear, and is connected to the carburetor throttle cable, which in turn is controlled by the accelerator grip. The oil pump automatically regulates the volume of lubricating oil according to engine speed and throttle valve opening, thus pumping the optimum amount of oil for engine lubrication under any operating condition.

This "automatic, separate lubrication" does not merely eliminate disadvantages in



---

the conventional pre-mix system, but it further improves the performance and efficiency of 2-stroke designs by eliminating certain oil-starvation conditions which formerly existed.

A) The Autolube feeds an optimum amount of lubricating oil to the engine under any operating condition, thus featuring:

- Less oil consumption.
- Less carbon accumulation.
- Less exhaust smoke.
- Improved lubricating efficiency.

B) The Autolube simplifies fuel supply, thus featuring:

- Using straight gasoline directly in the gas tank.
- Less fuel contamination.

C) The Autolube improves the reliability of lubrication, thus eliminating:

- Special care concerning oil/fuel mixing ratio.

### II-3. Handling the Oil Pump

The oil pump is a precision-machined assembly. Make no attempt to disassemble it. When you remove the oil pump from the engine, protect it from dust, dirt, etc., and after reinstalling it, bleed and adjust the pump correctly. Proper handling will keep the pump free from trouble.

The oil pump is similar in both construction and operation to other Autolube systems. The only difference is the employment of a 5.5  $\phi$  plunger because of larger consumption of oil by a 125 c.c. single cylinder engine.

#### II-3-A. Checking Minimum Pump Stroke

##### 1) Checking

- a. Fully close the accelerator grip.
- b. Turn the oil pump starter plate in the direction of the arrow marked on the plate. Then measure the gap between the adjustment pulley and the adjustment plate. Keep the gap as wide as possible by observing it with the eye.

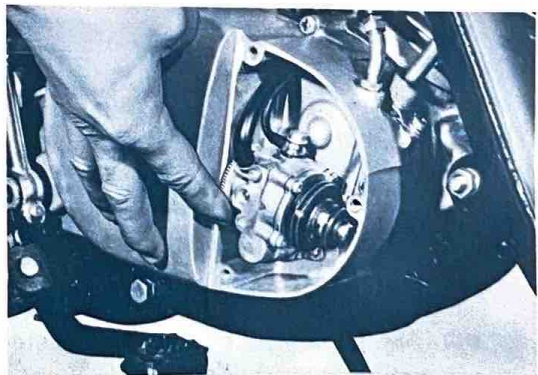

Fig. II-3-1

c. Insert a feeler gauge (0.15 mm.) into the gap.

When the gap allows it to enter  
.....Stroke is correct.

When the gap does not allow  
.....Stroke is insufficient.

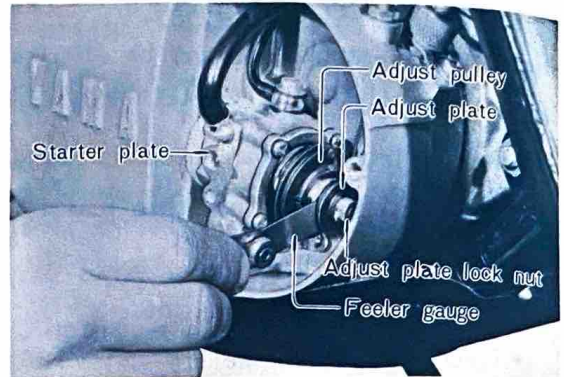

Fig. II-3-2

## 2) Adjustment

a. Remove the adjustment plate lock nut, and then remove the adjustment plate.

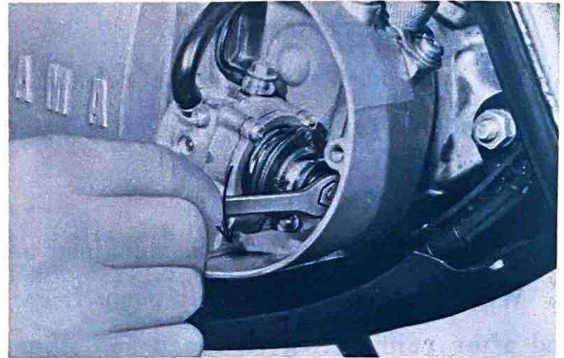

Fig. II-3-3

b. Install a 0.1 mm. adjustment shim where the adjustment plate was.

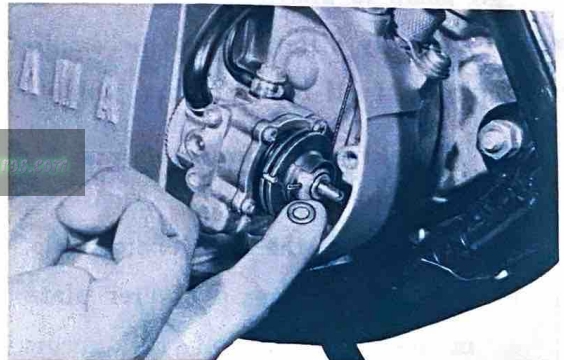

Fig. II-3-4

c. Reinstall the adjustment plate lock nut, and measure minimum stroke. When the gap allows a 0.20 mm. feeler gauge to enter but does not allow a 0.25 mm, the stroke is correctly adjusted.

Stroke adjustment tolerance.....0.20 to 0.25 mm.

### II-3-B. Carburetor and Autolube Cable Adjustments

Follow the preceding in section II-3-A steps to check minimum stroke, and adjust it if incorrect. Then adjust the pump and carburetor as described in the steps below.

#### 1) Throttle Cable Adjustment

- a. Adjust the carburetor with the engine at idle, and remove all but 1 mm of slack from throttle cable B.

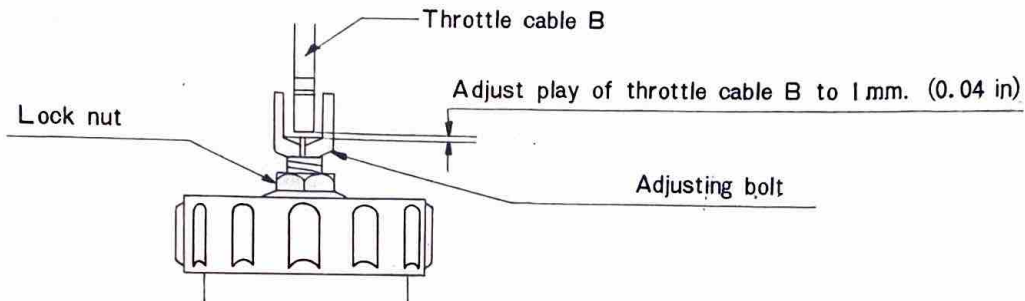

Fig. II-3-5

- To bring the play of the throttle cable into correct adjustment, loosen or tighten the throttle cable adjustment screw.
  - To check this adjustment, lightly pull throttle cable B, and engine speed should slightly increase from idling r.p.m.
- b. Next, adjust throttle cable(A) so that the gap as shown in Fig. II-3-6 below will be between 0.5 and 1.0 mm. (0.02~0.04 in.)

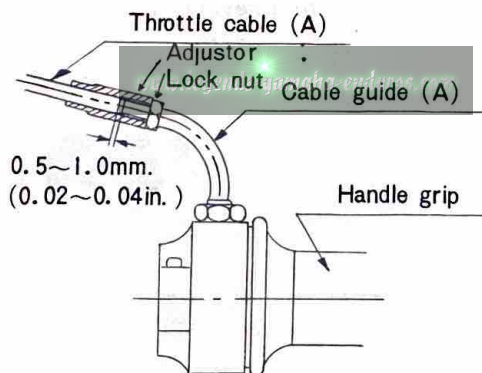

Fig. II-3-6

- Check the play of the throttle cable(A) by pulling the outer part of the throttle grip. If the play is excessive or insufficient, adjust the play with the adjustment screw.

## 2) Autolube Cable Adjustment

- a. Adjust the pump cable so that the marking (arrow) on the Autolube pump adjustment pulley is aligned with the guide pin (see Fig. II-3-8). Begin by fully closing the accelerator grip, then slowly turning it back again so that the slack in the throttle cable is completely taken up. Next, adjust the pump cable so that the marking on the pump adjustment pulley will be aligned with the guide pin, as shown in Fig. II-3-7. The point of adjustment is at the end of the cable, just before it enters the case. Loosen the lock nut and screw the adjustor in or out, whichever direction is necessary to obtain the correct adjustment.

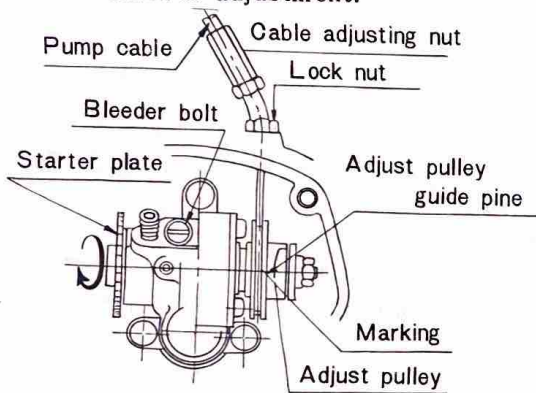

Fig. II-3-7



Fig. II-3-8

### II-3-C Bleeding

When the pump has been removed or the Autolube oil has run out, air will enter the pump. The air will cause an irregular flow of oil after the pump is mounted again or the oil is refilled. In order to prevent such an irregular flow of oil, bleed the pump in the following manner.

- 1) Remove the bleeder bolt.

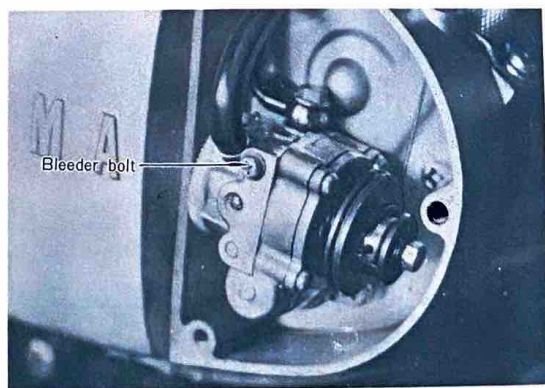

Fig. II-3-9

- 
2. Next, rotate the starter plate in the direction of the arrow marked on the plate. Continue turning the plate until no air comes out with the oil and tighten the bleeder bolt. To facilitate this bleeding, fully open the accelerator grip and rotate the starter plate. As the plunger stroke becomes greater, the air can be quickly bled.

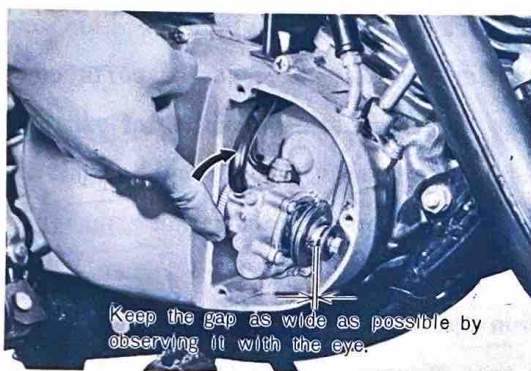

Fig. II-3-10

---

## Chapter III 5-Port Cylinder Induction System

### III-1 Description of 5-Port Cylinder Induction System.

The schnuerle loop scavenging system is the most commonly used induction system for the two-stroke engines. In the schnuerle loop system, two transfer ports on the right and left sides of the cylinder are employed to transfer 2 streams of fresh fuel in the loop design. This has proved to be the most effective induction system until the innovation of Yamaha's five-port cylinder. This conventional schnuerle loop system had a design limit in that the transfer ports could not be made large enough to completely clear the combustion chamber of exhaust gases because of the position of the intake and exhaust ports. This would result in a portion of exhaust gas remaining in the central area of the combustion chamber that would contaminate the fresh fuel charge.

The rotary valve induction system incorporates the use of a 3rd transfer port at the back of the cylinder that directs a fresh fuel charge to the dead area containing the remaining exhaust gases. But to incorporate the rotary valve system into the 125 c.c. single engine would result in physical design limitations of the engine. The physical limitations of excessive engine width and unattractive appearance restricts such an engine design.

Yamaha's Research and Engineering Departments, therefore, designed and perfected the five-port cylinder induction system that is used on the AT1-C and AT1-MX. This new five-port system, with the incorporation of two additional specially designed transfer ports, completely removes all the exhaust gases previously left in the dead area of the cylinder.

Engine performance is greatly increased with the use of this five-port system.

### III-2 Construction and Design of the 5-port Induction System

The 2 additional transfer passages are placed to the immediate rear of the standard transfer ports. These two additional ports run from the bottom of the cylinder up to the same height as the standard transfer ports. These additional ports are designed to direct the fresh charge at the area containing the remaining exhaust gases. As the fresh fuel charge enters the combustion area, the remaining exhaust gas is forced out the exhaust port, thus leaving the combustion area with an uncontaminated, full, fresh fuel charge. Therefore, these additional transfer ports

---

perform with equivalent efficiency the task so well done by the additional third port of the rotary valve induction system. This assures constant and equal performance, both at low engine speeds and high engine speeds.

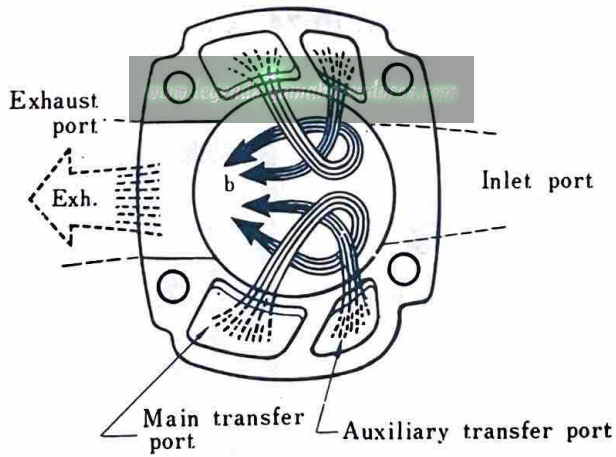
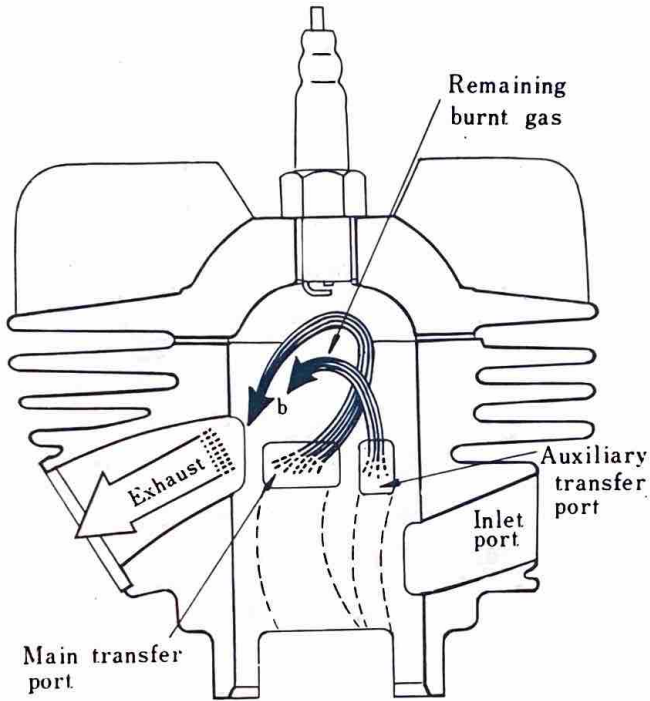

Fig. IV-2-1

---

## Chapter IV Engine

This chapter describes the disassembly and reassembly of the engine, its removal from the chassis, and the necessary service data. However, except when overhauling the crankshaft assembly, transmission, shifter mechanism, or bearings and oil seals in the crankcase, it is suggested that engine be serviced without removing it from the chassis. This will save a lot of time and labor.

### Preparation for disassembly of the engine:

- 1) All dirt, mud, dust, and foreign material should be thoroughly removed from the exterior of the engine assembly before removal and disassembly. This will prevent any harmful foreign material from entering the interior of the engine assembly.
- 2) Before engine removal and disassembly, be sure you have proper tools and cleaning equipment so you can perform a clean and efficient job.
- 3) During disassembly of the engine, clean all parts and place them in trays in order of disassembly. This will make assembly time faster and easier, and insure correct installation of all engine parts.

### IV-1 Engine Removal

1. Start the engine and warm it up for a few minutes, then turn off the engine and drain the transmission oil. (Fig. IV-1-1)

**Volume of oil: 700~800 c.c. (0.74~0.85 USqt.)**

**(SAE10W/30)**

[www.legenis-yamaha-enduros.com](http://www.legenis-yamaha-enduros.com)

2. Remove the muffler.
  - 1) Remove the two springs and two bolts. (Figs. IV-1-2 and 3)
  - 2) Remove the muffler holding bolts. (Fig. IV-1-4)

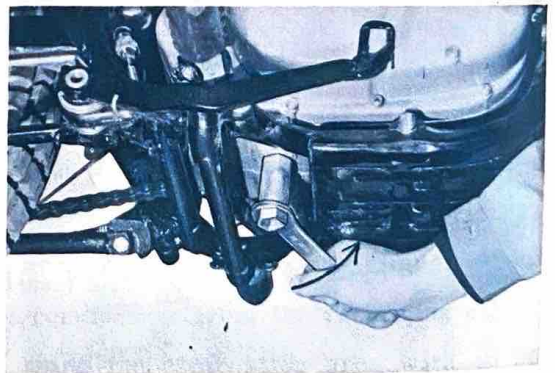

Fig. IV-1-1



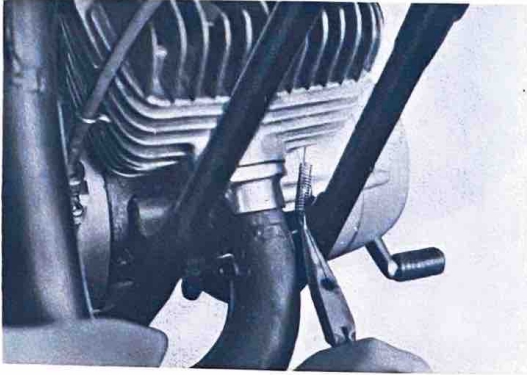

Fig. IV-1-2

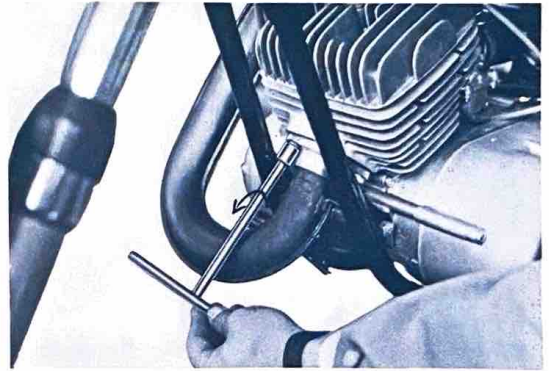

Fig. IV-1-3

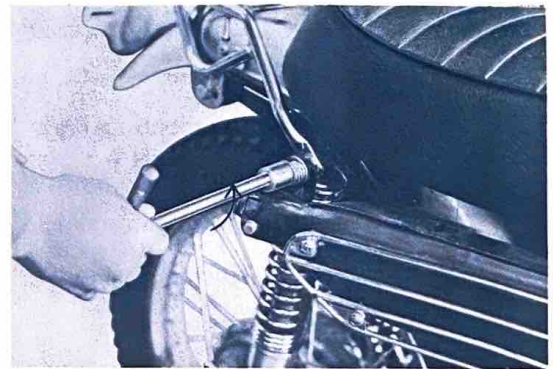

Fig. IV-1-4

3. Remove the change pedal.

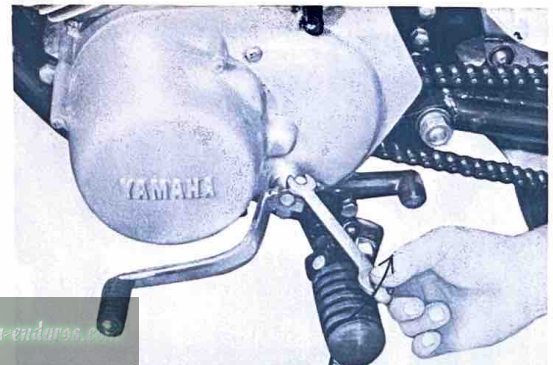

Fig. IV-1-5

4. Remove the lefthand crankcase cover.

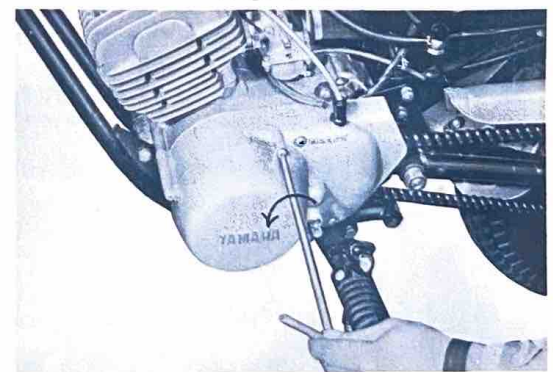

Fig. IV-1-6

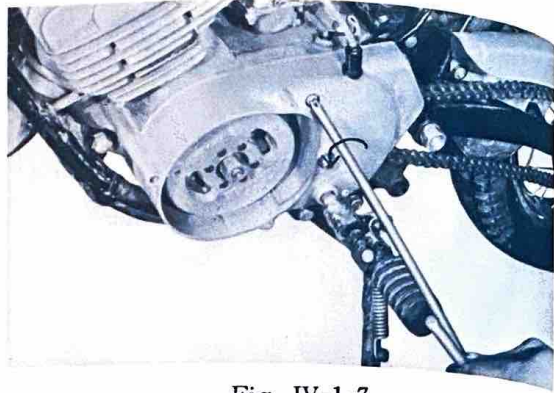

Fig. IV-1-7

5. On the AT1-C, equipped with a dynamo, all wire leads should be removed from the stator terminals. (Fig. IV-1-8.) On the AT1-MX, equipped with a flywheel magneto, the wiring should be disconnected from the wire harness center at its connector. (Fig. IV-1-7)

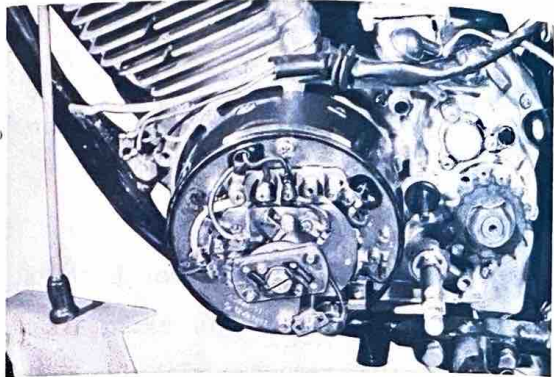

Fig. IV-1-8

6. Disconnect the master link and remove the chain.

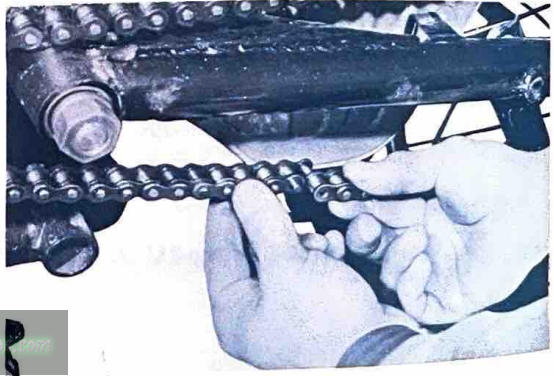
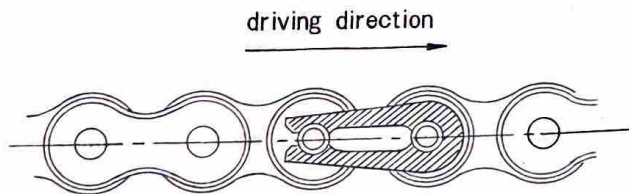

Fig. IV-1-9

When jointing, be sure the drive chain master link is facing in the correct direction.



After jointing, adjust the chain free play to 25 mm. (1 in.) up and down at the center of the lower section with the rear wheel on the ground.

7. Remove the pump cover and pump cable.

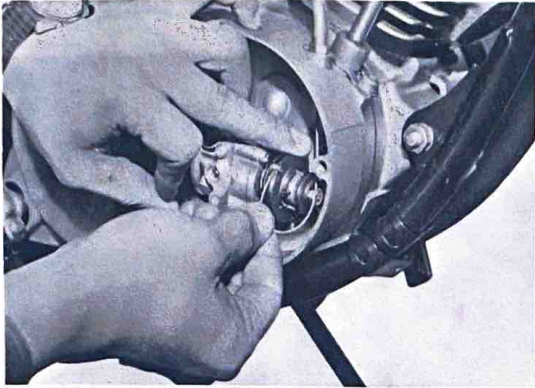

8. Remove the tachometer cable.

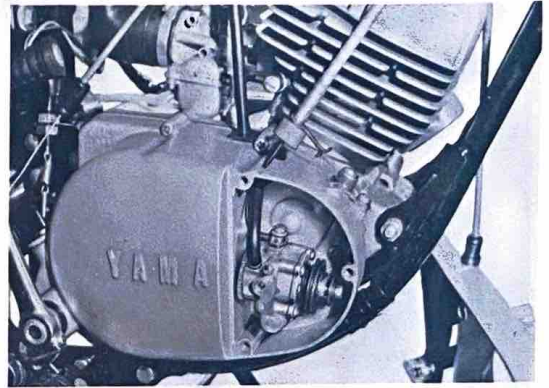

Fig. IV-1-11

9. Remove the air cleaner rubbers.

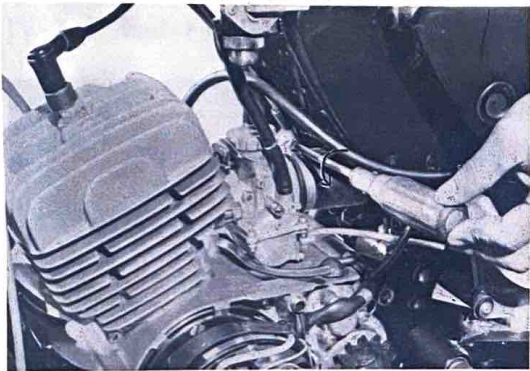

Fig. IV-1-12

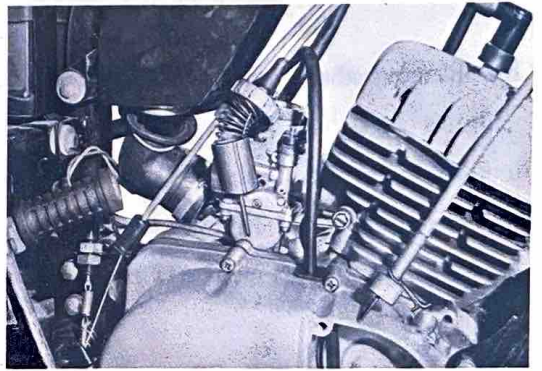

Fig. IV-1-13

10. Disconnect the oil line and be sure to plug the hole to prevent oil from flowing out.

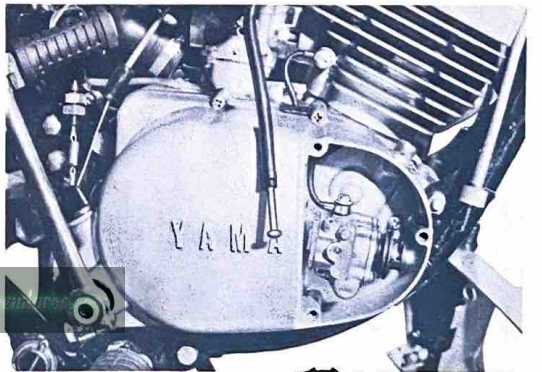

Fig. IV-1-14

11. Disconnect the fuel line at the bottom of the fuel tank.



Fig. IV-1-15

12. Remove the three engine mounting bolts.

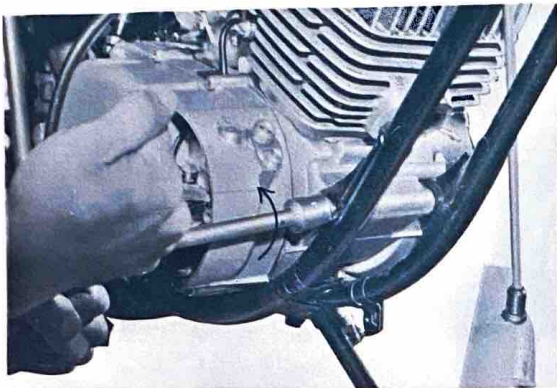

Fig. IV-1-16

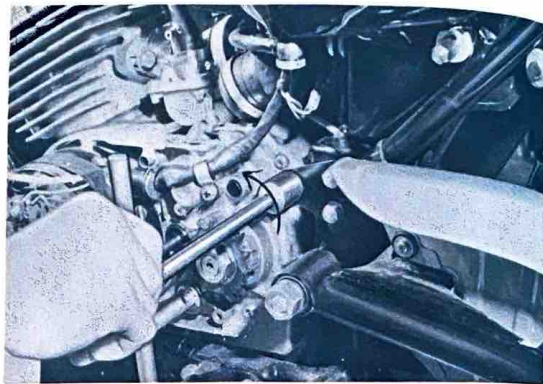

Fig. IV-1-17

13. Remove the engine from the frame.

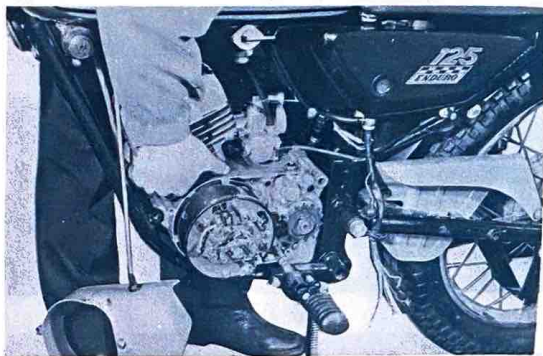

Fig. IV-1-18

## IV-2 Cylinder Head

The cylinder head is bolted on the cylinder with special nuts.

### A. Removing

Remove the four special nuts from the top of the cylinder head, then the head and head gasket. Reverse the sequence for reinstallation. Replace the gasket, if damaged. Cylinder head tightening torque is 15~18 ft-lbs. (2.0 kg-m)

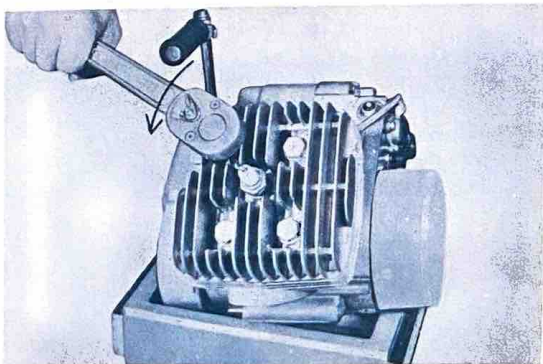

Fig. IV-2-1

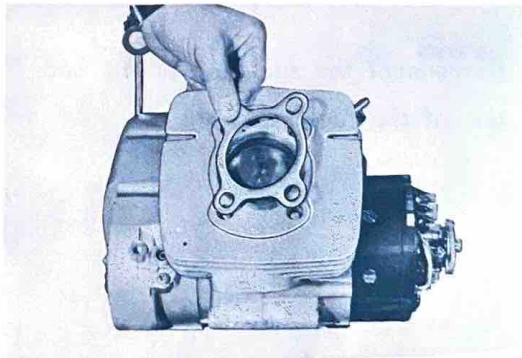

Fig. IV-2-2

---

## B. Removing Carbon Deposits

Carbon deposits inside the cylinder head combustion chamber and top of the piston will result in an increase in the compression ratio, as well as preignition and engine overheating. Scrape the cylinder head and piston dome clean.

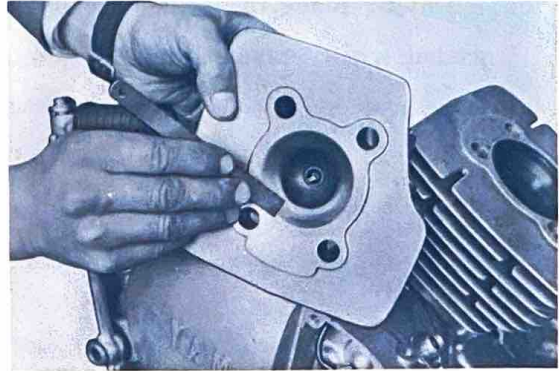

Fig. IV-2-3

## IV-3 Cylinder

The Yamaha 125 AT1-C and AT1-MX engine employs an aluminum cylinder sleeved with special cast iron, that provides improved cooling efficiency and light weight. Like the DT1 engine, the cylinder is of 5-port design with superior scavenging efficiency.

\* The same type of cylinder is used on the AT1-MX, but for better performance the cylinder's ports are laid out in a different way and are larger as compared with the AT1-C standard.

### A. Removing the Cylinder

- 1) Remove the oil delivery line banjo bolt from cylinder.

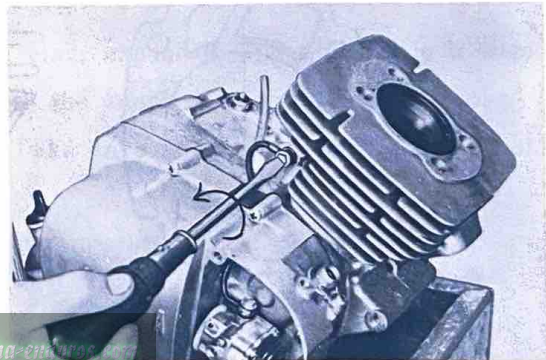

Fig. IV-3-1

- 2) Remove the cylinder by striking it lightly with a plastic or rubber hammer.

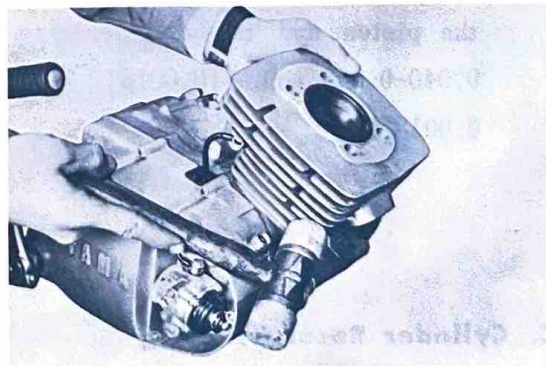

Fig. IV-3-2

- 3) Always replace the cylinder base gasket when reassembling.

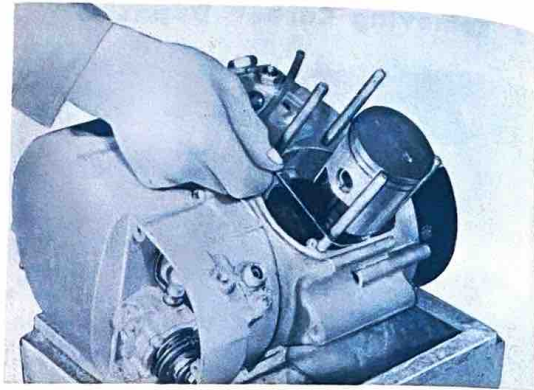
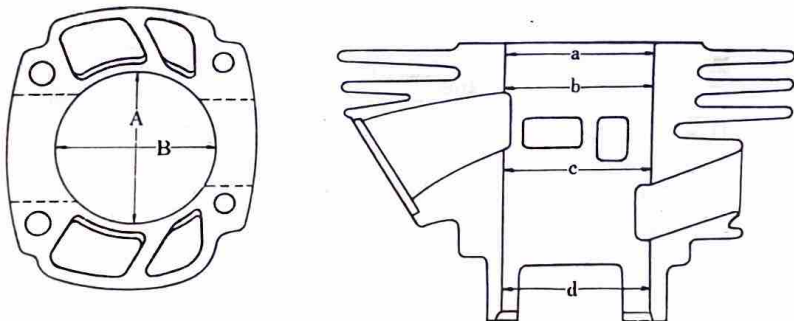

Fig. IV-3-3

### B. Checking the Cylinder for Wear

- 1) Measure the amount of wear of the cylinder wall with a cylinder bore measuring micrometer or cylinder gauge. (Measure it at four depths while positioning the instrument at right angles to the crankshaft.) If the difference between the maximum and minimum diameter exceeds 0.05 mm. (0.0019"), rebore and hone the cylinder.



www.legends4u.com Fig. IV-3-4

- 2) The minimum clearance between the piston and the cylinder is 0.040-0.045 mm. (0.0016" and 0.0018")

### C. Cylinder Reconditioning

- 1) Pistons are available in 0.25 and 0.50 mm. (0.010" and 0.020") oversizes.

- 
- 2) The cylinder should be rebored and honed to the diameter of the oversize piston plus the minimum allowable clearance. (IV-3-B-2.)
  - 3) The error between the maximum and minimum diameters after honing should be no more than 0.04 mm. (0.0015")

#### **D. Removing Carbon Deposits**

Scrape off the carbon accumulation in the exhaust port of the cylinder with the dulled end of a hacksaw blade.

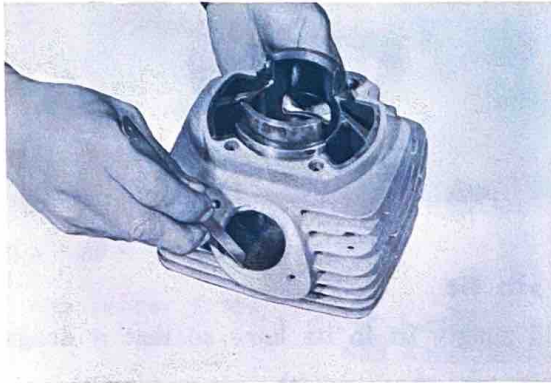

Fig. IV-3-5

#### **E. Installing the Cylinder**

Put your fingers at each end of the piston ring, expand the ring, and slip it onto the piston. Align both ends of the ring with the knock pin in each ring groove. Next, insert the piston into the cylinder. Take care not to damage the bottom of the cylinder with the rings.

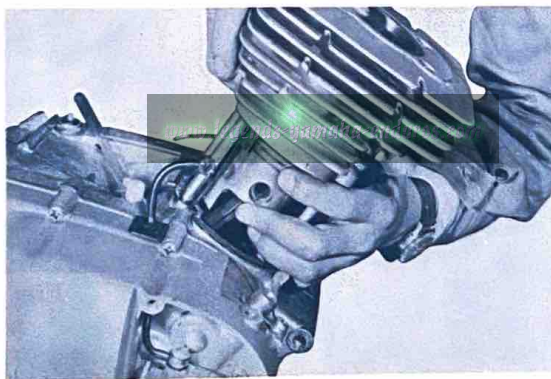

Fig. IV-3-6

### **IV-4 Piston Pin**

#### **A. Pulling out the Piston Pin**

Remove the clips at both ends of the piston pin with needle nose pliers, and

---

press out the piston pin with a finger or a slot-head screw driver.

Note: Before removing the piston pin clips, cover the crankcase with a clean rag, so you will not accidentally drop the clip or other foreign particles into the crankcase.

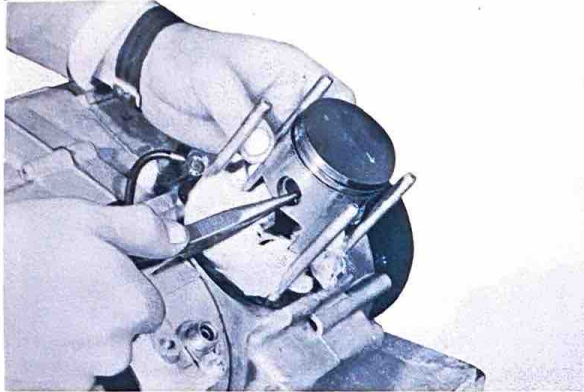

Fig. IV-4-1

### B. Piston-to-Piston pin Fit

The piston pin should snugly fit in its bore so that it drags a little as you turn it. If the piston pin is loose, replace the pin and/or the piston.

If the pin has step-wear in its center, replace the needle bearing as well as the piston pin. Check the small end of the connecting rod for wear by inserting the piston pin.



Fig. IV-4-2

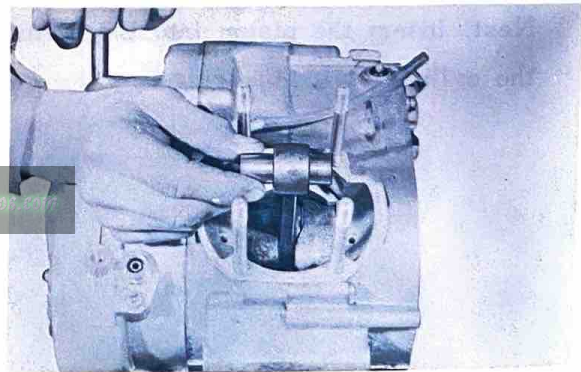

Fig. IV-4-3

## IV-5 Piston Ring

### A. Removing the Piston Rings

Put your thumbs at each end of the piston ring and pull the piston ring ends apart. Remove the ring by moving the ring off the piston on the other side of the ring ends.



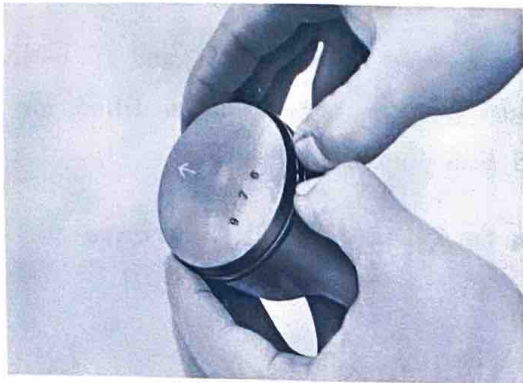

Fig. IV-5-1



Fig. IV-5-2

### B. Installing the Piston Rings

First fit No. 2 ring over the piston, and then the No. 1 ring, and align their end gaps with the locating pin in each ring groove. (Fig. IV-5-3)

The printing on all rings must face up to position the gap properly at the pin.

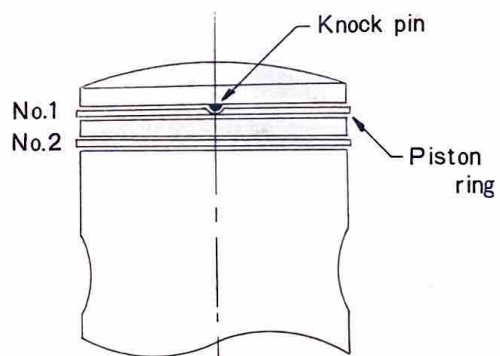

Fig. IV-5-3

### C. Checking the Piston Rings

#### 1) Measuring piston ring wear

Put the ring into the cylinder so that the ring is parallel to the cylinder bottom edge, and then measure the end gap with a feeler gauge (Fig. IV-5-4).

The end gap should be between 0.15 and 0.35 mm. (0.006"~0.014") for both No. 1 and No. 2 rings. [0.4~0.6 mm. (0.016"~0.024") with GYT kit.]

#### 2) Removing carbon

Carbon on the piston rings and in the ring grooves will make the rings stick in the piston, thus causing gas blow-by.

Remove the rings from the piston, and clean the carbon from the rings and ring grooves.

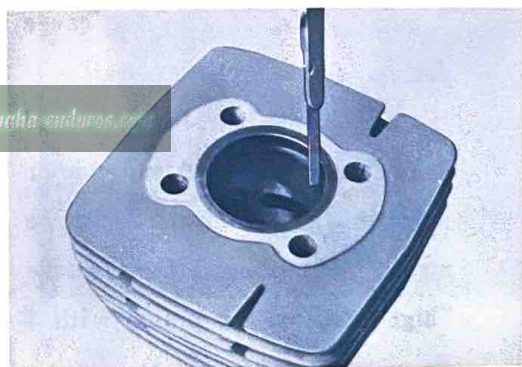

Fig. IV-5-4

## IV-6 Piston

The piston is made of a high-silicon aluminum alloy. Both AT1-C and AT1-MX employ the same type of piston, but the piston for the AT1-MX is modified for higher performance than the AT1-C standard type piston.

### A. Checking and Correcting the Piston to Cylinder Wall Clearance

#### 1) Measuring piston clearance

Piston clearance is the difference between the minimum cylinder bore diameter and the maximum outside diameter of the piston. As described in IV-3 Cylinder, piston clearance should be 0.040-0.045 mm. (0.0016-0.0018 in.)



Fig. IV-6-1

To determine the maximum piston diameter, measure the piston with a micrometer at right angles to the skirt 10 mm. (3/8 in.) from its bottom edge. (Fig. IV-6-1)

#### 2) Checking and correcting scratches on the piston

A piston showing sign of seizure will result in noise and loss of engine power. It will also cause damage to the cylinder wall.

If a piston that has seized is used again without correction, another seizure will develop at the same area. Lightly sand the seizure



Fig. IV-6-2

“high spot” on the piston with #400 sandpaper until smooth. (Fig. IV-6-2)

#### 3) Removing Carbon

Remove carbon accumulations on the piston head, using a screwdriver or a saw-blade. (Fig. IV-6-3)

Carbon and gum accumulations in the piston groove will result in piston ring seizure. Remove them from the ring groove. (Fig. IV-6-4)

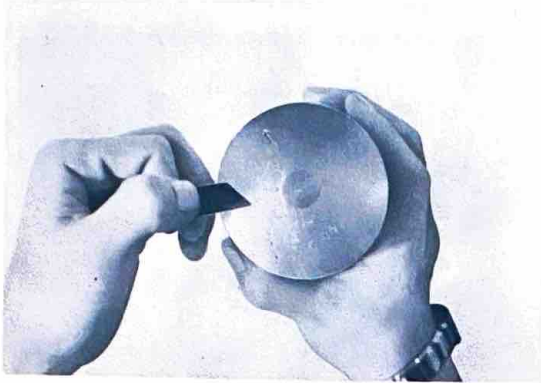

Fig. IV-6-3



Fig. IV-6-4

### **B. Piston Installation Direction**

Install the piston with the arrow mark on the head pointing forward (toward the exhaust port of the cylinder).

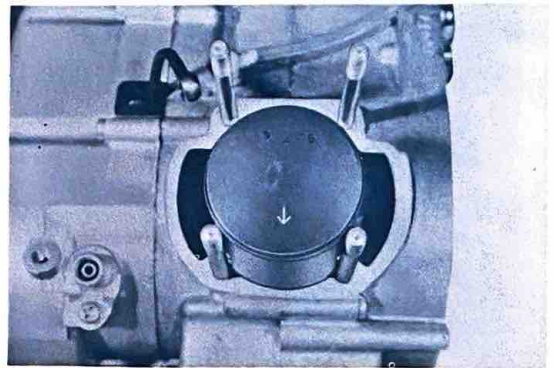

Fig. IV-6-5

### **IV-7-1 Flywheel Magneto (AT1-MX)**

A. Remove the nut using a flywheel magneto holding tool.



Fig. IV-7-1

- B. Install the flywheel magneto puller.  
Turn it left and the flywheel magneto will break loose.

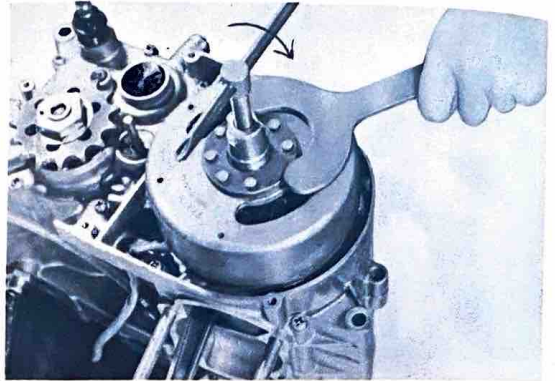

Fig. IV-7-2

- C. Remove the three screws holding the flywheel magneto base to the crankcase, and remove the flywheel magneto base.

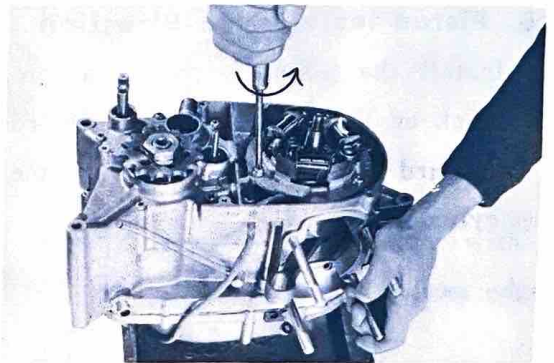

Fig. IV-7-3

- D. Remove the woodruff key.

It is advisable to place the woodruff key on the flywheel magnets (using its magnetic force) while the key is removed for engine service.

#### IV-7-2 Starter Dynamo (AT1-C)

The AT1-C is equipped with a starter dynamo for easy starting.

- A. Remove the armature bolt, governor, and cam. (Fig. IV-7-4 and 5)

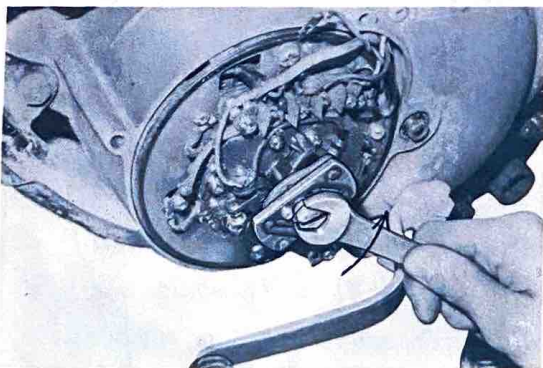

Fig. IV-7-4

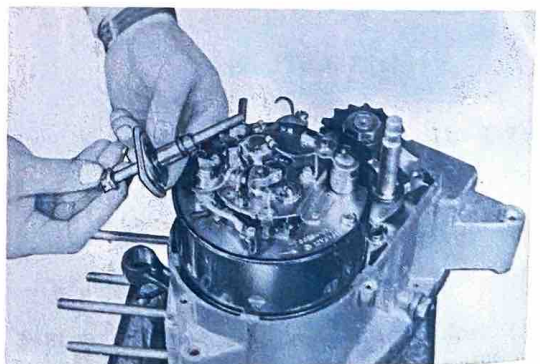

Fig. IV-7-5

- 
- B. Remove the yoke mounting bolts, and then the yoke assembly (Fig. IV-7-6)

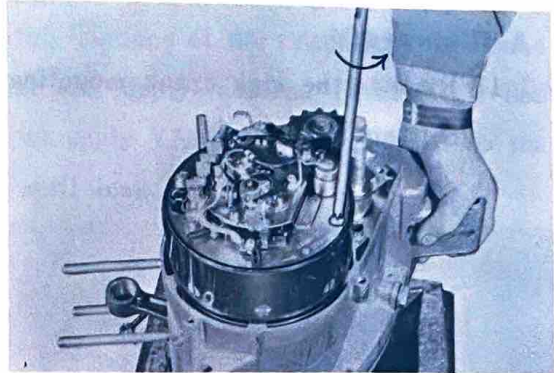

Fig. IV-7-6

- C. Pull out the armature with the armature puller bolt or slide hammer. (Fig. IV-7-7).

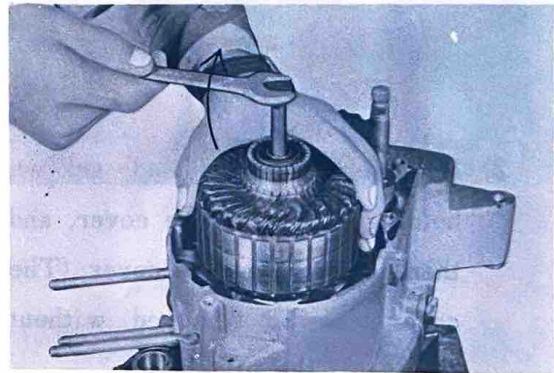

Fig. IV-7-7

- D. Remove the woodruff key. (Fig. IV-7-8)

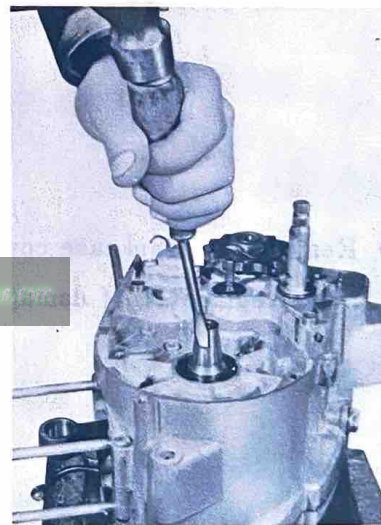

Fig. IV-7-8

---

## IV-8 Crankcase Cover (R.H.)

### A. Removal

- 1) Remove the kick crank mounting bolt and the crank.

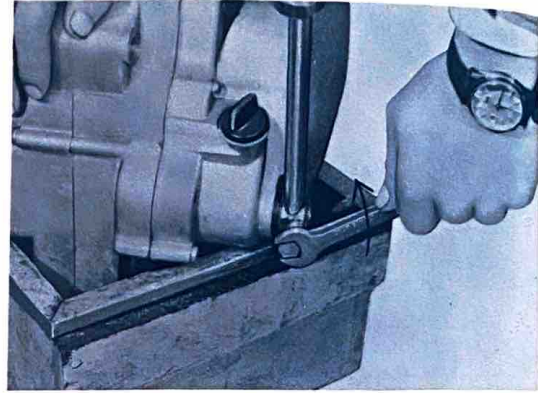

Fig. IV-8-1

- 2) Remove the pan head screws holding the crankcase cover, and then remove the case cover. (The cover can be removed without taking off the oil pump.)

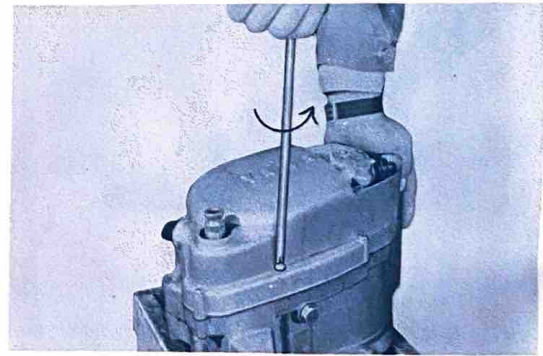

Fig. IV-8-2

- 3) Remove the crankcase cover gasket. Replace it, if damaged.

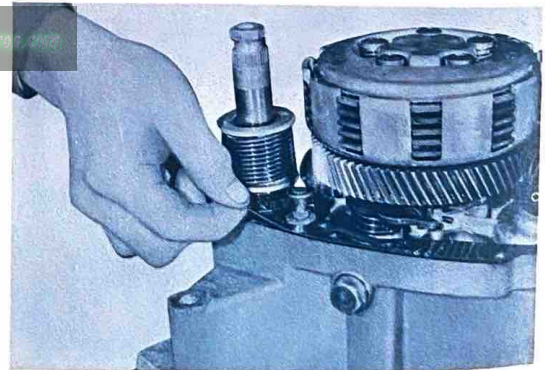

Fig. IV-8-3

---

## B. Installation

Spread YAMAHA Bond No.5 over the mating surface of the crankcase R. Place the crankcase cover gasket on the crankcase and apply Yamaha Bond No.5 and replace the crankcase cover R. Be sure to apply YAMAHA Bond No.5 to the mating surface; otherwise, the crankcase will leak.

**Note:** When installing the crankcase cover(R), make sure that the pump drive gear (made from synthetic resin) is correctly engaged with the primary drive gear.

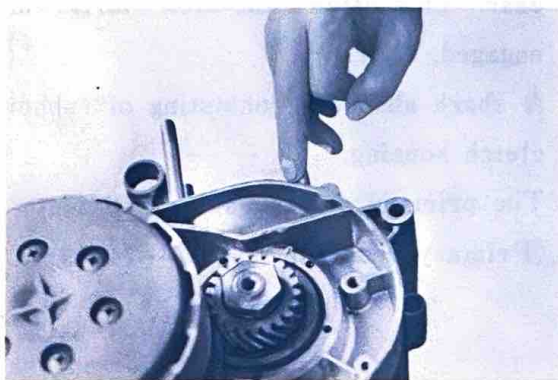

Fig. IV-8-4

## IV-9 Clutch

The clutch is a wet, multi-disc type, consisting of five molded cork friction plates and five clutch plates in the clutch housing that is mounted on the transmission main axle. To disengage the clutch, an inner push rod system is employed. The primary driven gear, coupled with the clutch housing, is meshed with a kick pinion gear. This allows the kick starter to be operated with the clutch disengaged or engaged.

A shock absorber consisting of rubbers is between the primary driven gear and the clutch housing.

The primary drive gear has 19 teeth, and the primary driven gear 74 teeth.  
 (Primary reduction ratio..... $74/19=3.894$ )

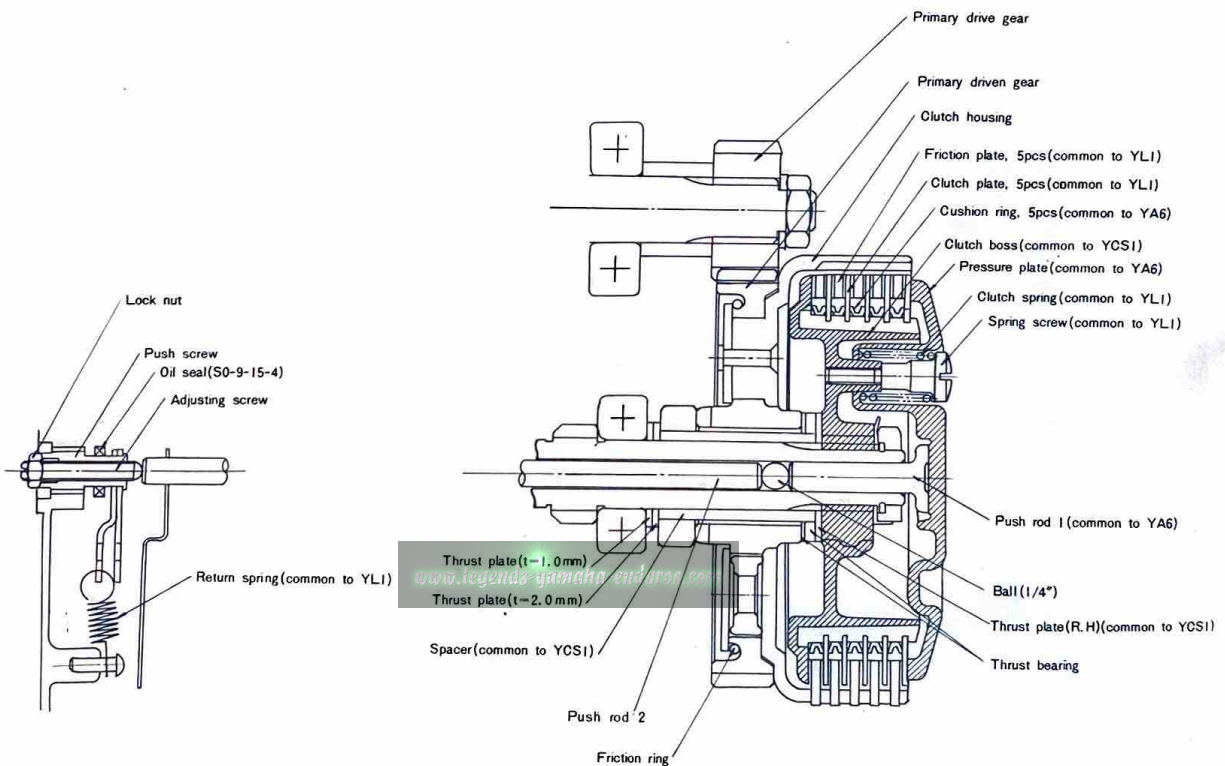

Fig. IV-9-1



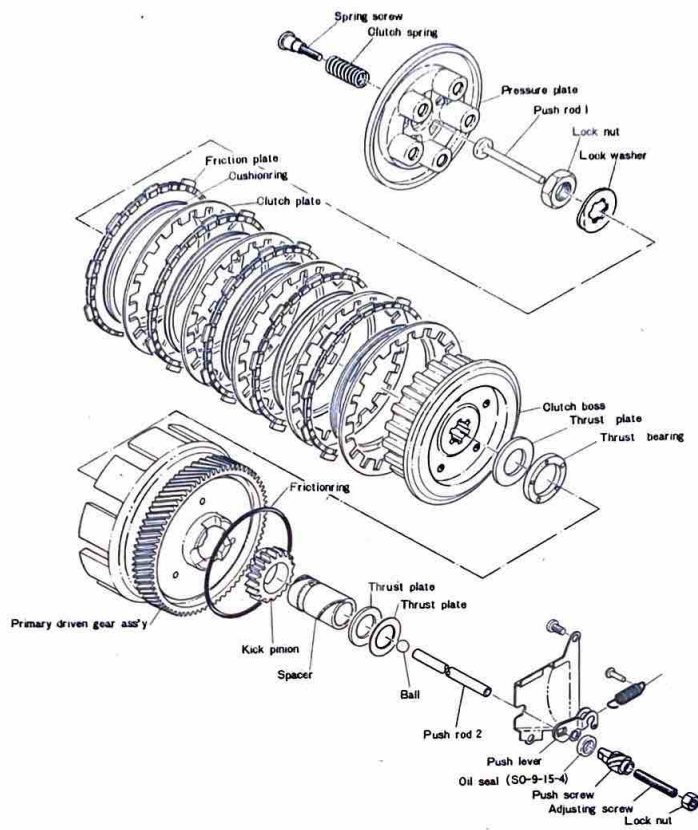

Fig. IV-9-2 Clutch ass'y exploded view

**A. Removing the Pressure Plate**

Remove the five clutch spring holding screws, and take out the pressure plate and push crown.

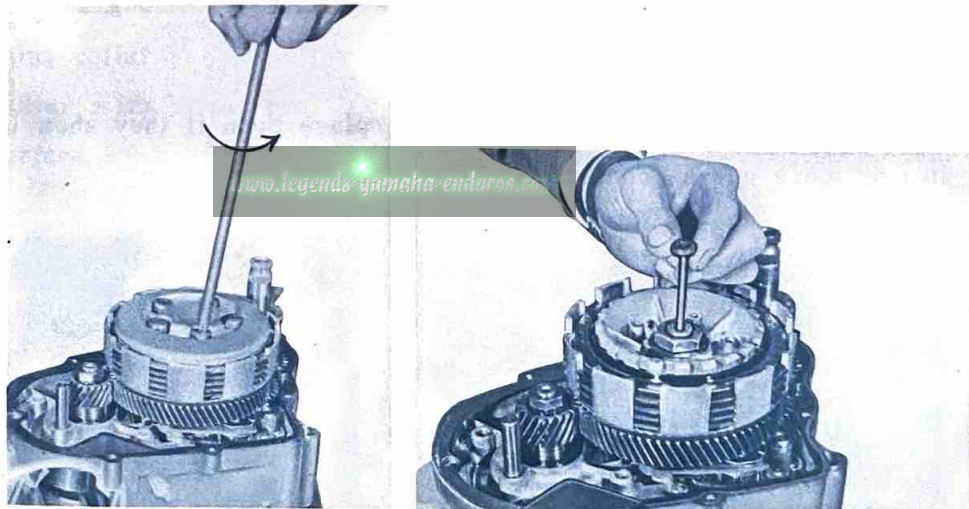

Fig. IV-9-3

Fig. IV-9-4

**B. Removing the Clutch Boss**

Install the clutch holding tool (same as YA7, YL1, CS2-C) on the clutch boss. Loosen the lock nut, and then remove the clutch boss.

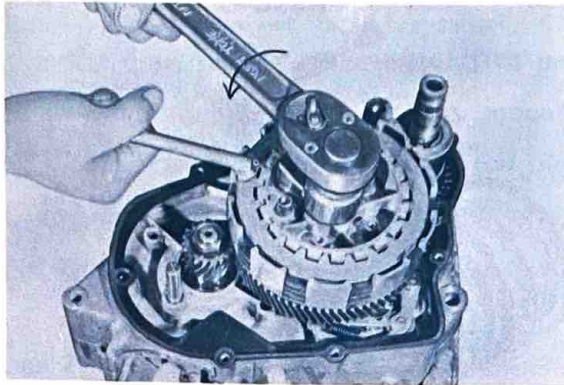

Fig. IV-9-5

### C. Checking the Clutch Spring

If the free length of the spring is 1 mm. (0.04 in.) or more shorter than the standard free length, replace it.

Free length 31.5 mm. (1.240 in.)

Fig. IV-9-6

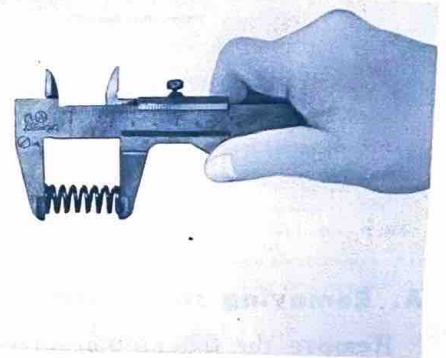

Fig. IV-9-7

### D. Checking the Friction Plates

Inspect the friction plates for wear. Replace them if they show 0.4 mm. (0.157 in.) or more uneven contact.

Standard thickness 4.0 mm. (0.157 in.)

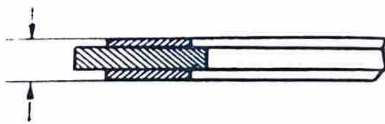

Fig. IV-9-8



Fig. IV-9-9

---

### E. Clutch Housing Assembly (integrated with the primary driven gear).

There is a rubber friction ring placed on the outside of the clutch between the primary driven gear and the clutch housing in order to reduce gear noise at low engine speeds.

#### 1) Inspection

Insert the primary gear retaining collar (spacer) in the primary driven gear boss and check it for radial play. If the play is excessive (allowable clearance is between 0.009~0.048mm.), replace the gear retaining collar because it will cause excessive noise.

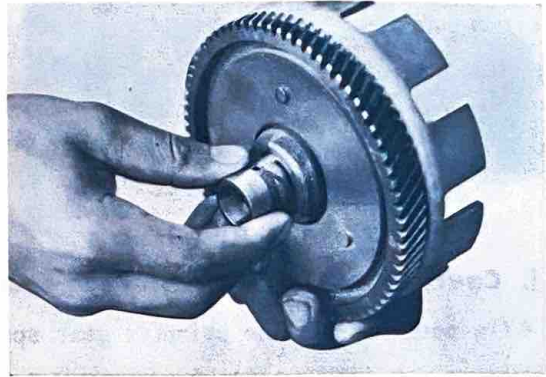

Fig. IV-9-10

If any scratches are found, replace the spacer to avoid impaired clutch action.

### F. Checking the Primary Gear Retaining Collar (Spacer)

Place the primary gear retaining collar around the main axle and again check it for radial play. If play exists (allowable clearance is between 0.020~0.062 mm.), replace the gear retaining collar.

Replace any collar with step-wear on its outer surface.

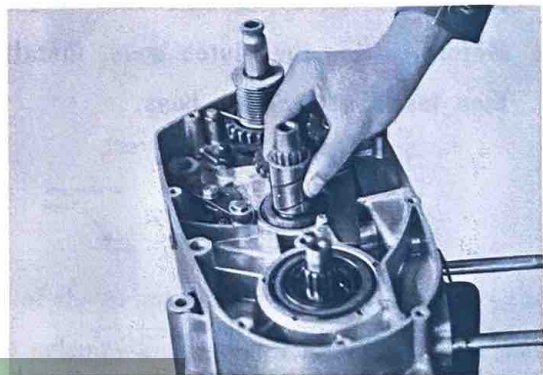

Fig. IV-9-11

### G. Fitting Cushion Rings

A cushion ring is installed between the clutch boss and each of the friction plates to insure even engagement and complete disengagement of the plates. When fitting cushion rings, be sure they are flat and not twisted.

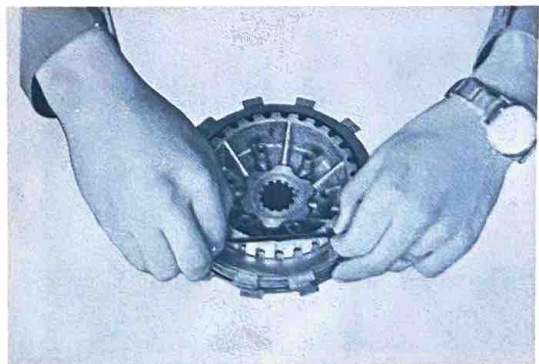

Fig. IV-9-12

## H. Checking the Push Rod

Remove the push rod and roll it over a surface plate. If the rod is bent, straighten or replace it.

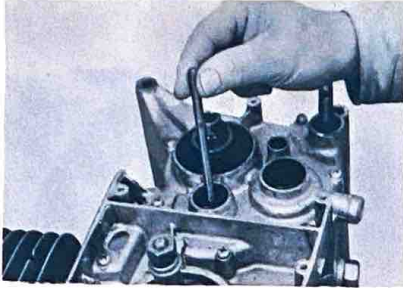

Fig. IV-9-13

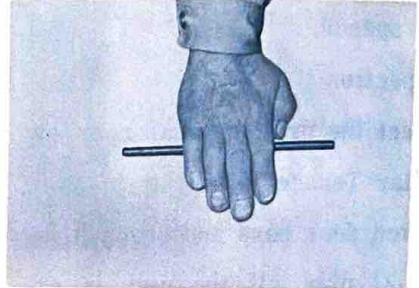
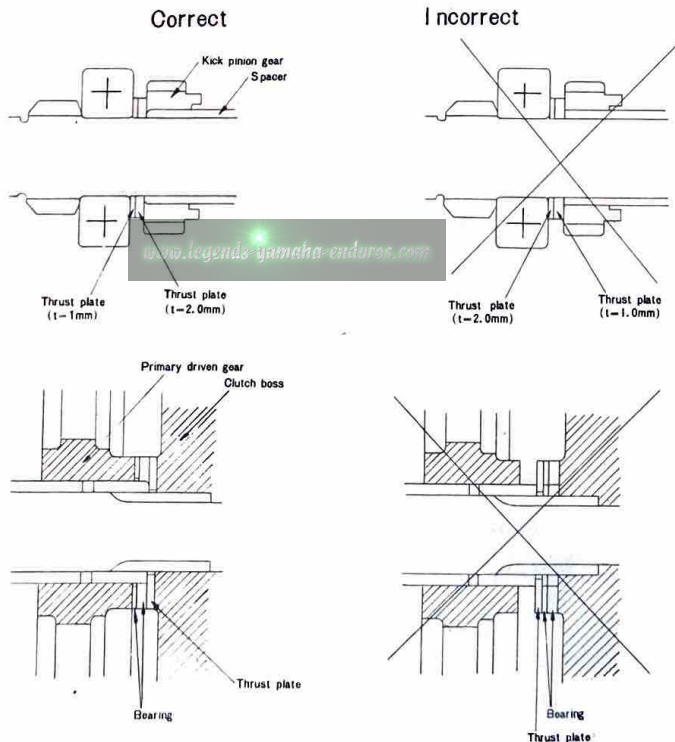

Fig. IV-9-14

## I. Caution on Re-assembling the Clutch

- \* On both ends of the primary gear spacer are thrust washers and thrust bearings. If these washers and bearings are incorrectly installed, or omitted, the clutch boss will directly rub on the primary driven gear, impairing clutch action.
- \* The thrust bearing assembly fits on the primary retaining collar, but it may slip out of place when installing clutch boss. Therefore, apply grease to both surfaces of the bearing to make it stick to the gear retaining collar. Before fitting the clutch boss, install the clutch plates, friction plates, etc., and then install the clutch boss.



## J. Adjusting the Clutch

### 1) Setting the Adjusting Screw

Turn the adjusting screw in until it lightly seats against the push rod.

Next, back the screw off  $\frac{1}{4}$  turn to get the proper spacing, then tighten the lock nut.

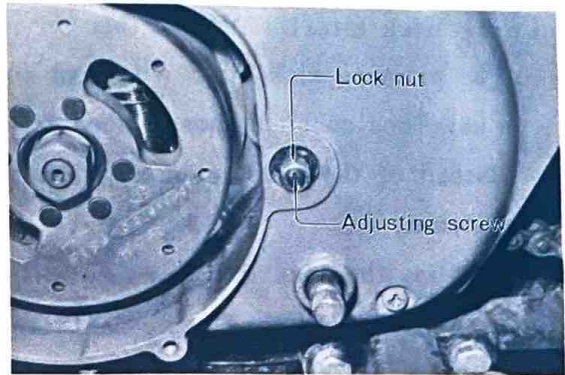

Fig. IV-9-15

### 2) Adjusting the Clutch Cable Tension

The clutch cable becomes slackened after being used for a long time.

Occasionally the cable must be adjusted so that the play at the clutch handle is from 2 to 3 mm. (1/16~1/8 in.)

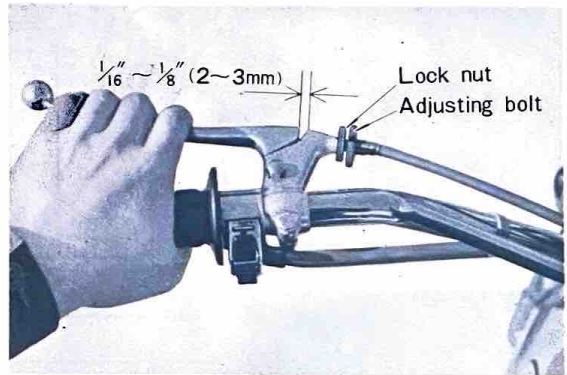

Fig. IV-9-16

## IV-10 Primary Drive Gear

### A. Removal

Feed a rolled-up rag between the teeth of the primary drive gear and the primary driven gear to lock them, and loosen the primary drive gear lock nut. The primary gear can then be forced off by using two screwdrivers, as shown in Fig. IV-10-2.

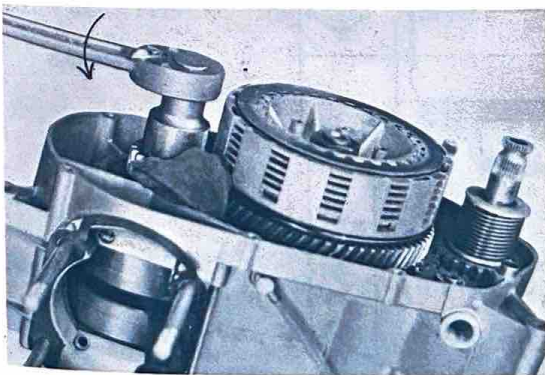

Fig. IV-10-1

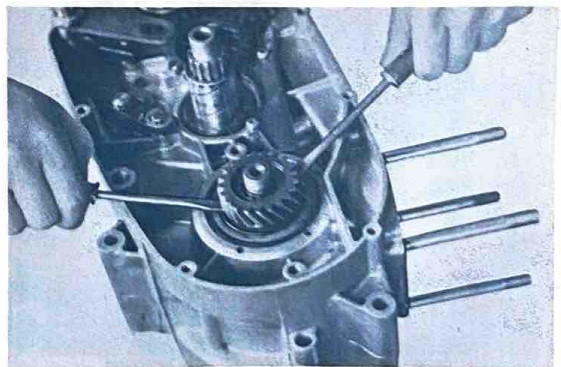

Fig. IV-10-2

## IV-11 Kick Starter Mechanism

The primary kick-starter system (one-touch kick-starter) is employed. However, a new "non-constant-mesh" mechanism has been introduced into the AT1 kick-starter, instead of the constant-mesh kick gear type, such as the ratchet and roller-rock systems.

That is, the kick gear meshes with idler gear only when the kick starter pedal is kicked. After the engine has started, the kick gear and the idler gear disengage. This mechanism not only eliminates noise resulting from the constant mesh of the kick with the idler gear, but also greatly contributes to the durability of the kick starter assembly.

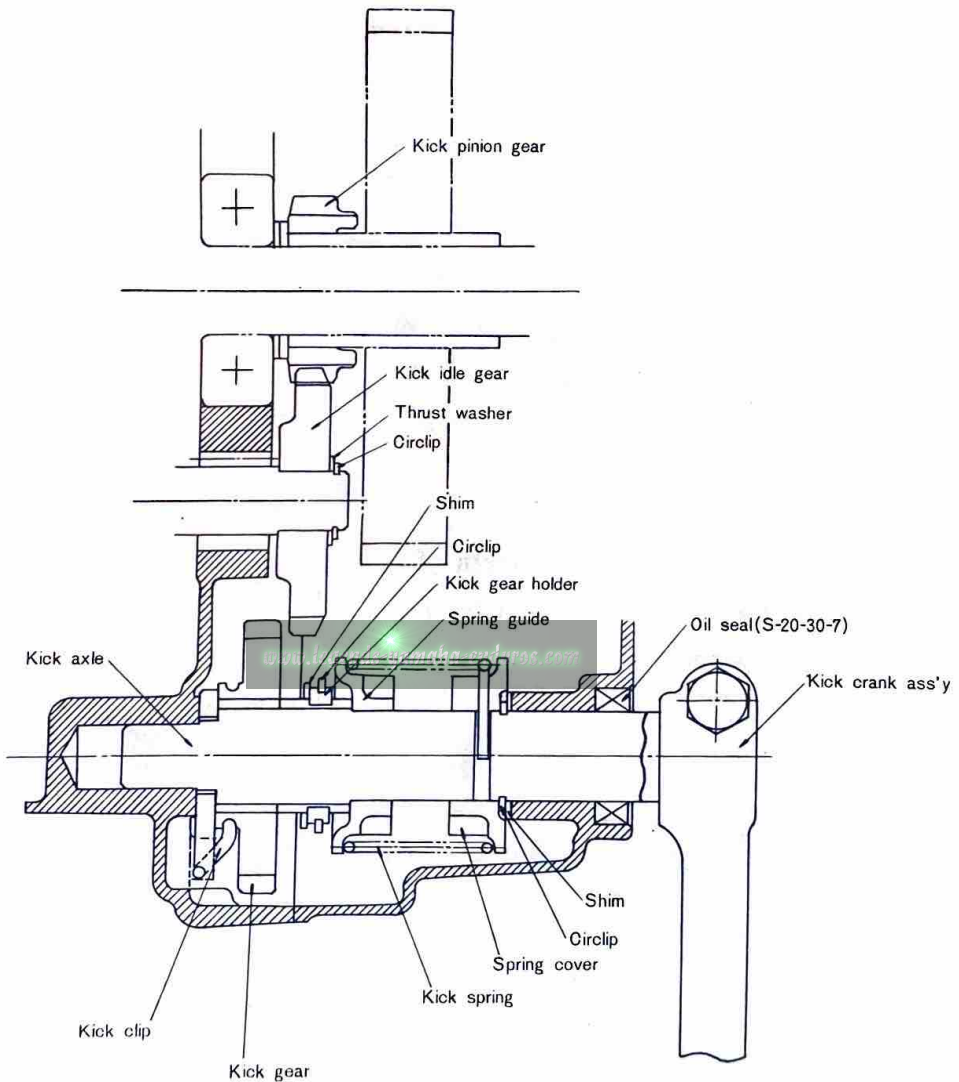

Fig. IV-11-1

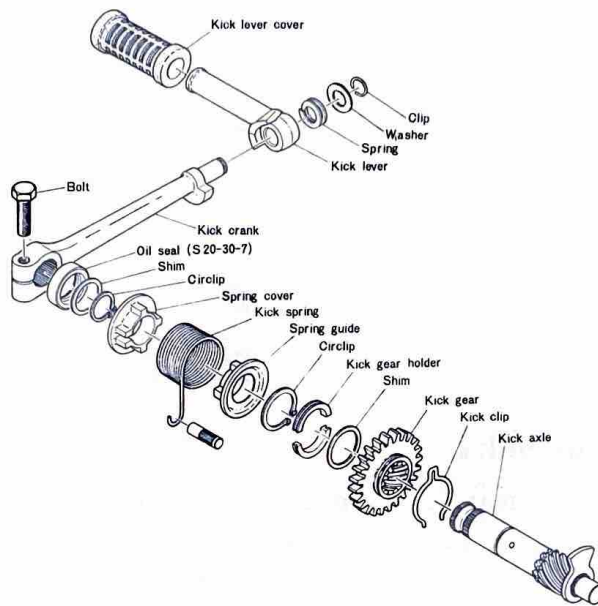
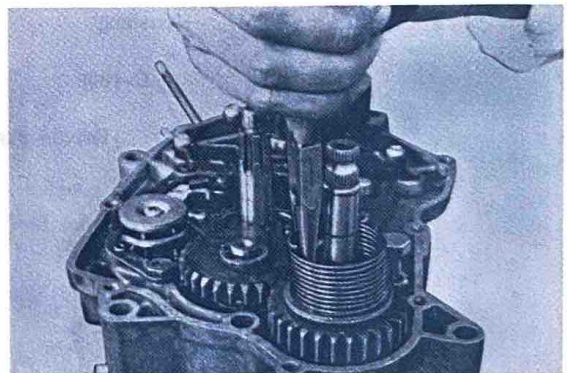

Fig. IV-11-2

### A. Removal

- 1) Remove the kick spring



[www.legends-yamaha-enduros.com](http://www.legends-yamaha-enduros.com)

Fig. IV-11-3

- 2) Then remove the kick starter assembly

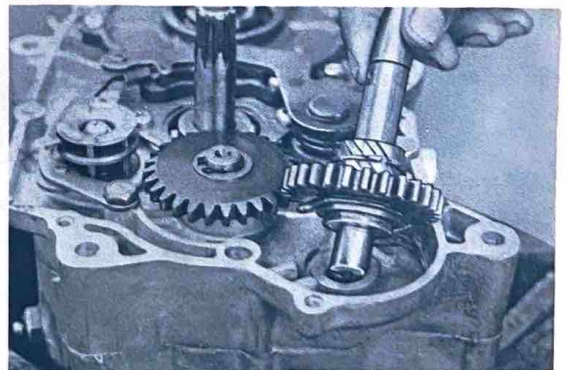

Fig. IV-11-4

## B. Removing the Kick Idler Gear

Remove the circlip with clip pliers. Then the kick idler gear can be easily removed.

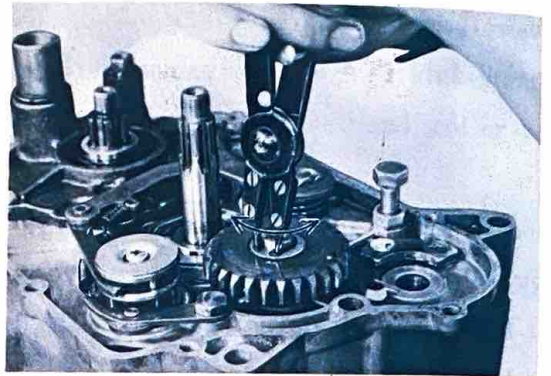

Fig. IV-11-7

## C. Tachometer gear units

The tachometer drive gear is engaged with the primary drive gear to convey the revolutions per minute of the crankshaft to the tachometer through the tachometer cable.

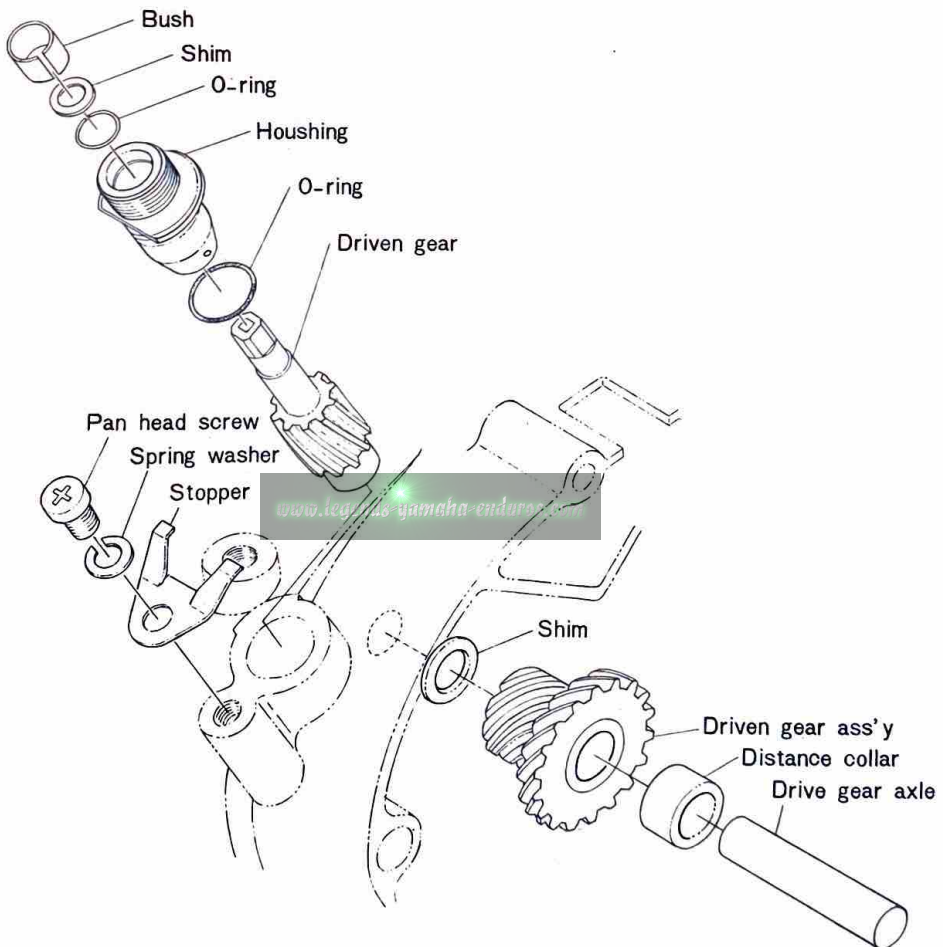

Fig. IV-11-8



## IV-12 Shift Mechanism

The AT1-C shift mechanism is operated in five stages by a see-saw type change pedal. As the change pedal is depressed, gear shift arm B moves gear shift arm A, which in turn pushes on one of the gear shift pins attached to the gear shift drum, thereby turning the gear shift drum. A total of five gear shift pins are attached to the drum, and therefore, each time the change pedal is depressed, the drum rotates  $1/5$  of a revolution.

That is, one full turn of the gear shift drum is made in five stages; 1st, 2nd, 3rd, 4th and 5th.

Slotted guides are grooved in the shift drum, and the shift fork cam follower pins are placed in these slotted guides. Therefore, as the drum turns, the shift forks slide back and forth in the slotted guides. Shift fork (1) moves the 2nd and 3rd gears, shift fork (2) the 1st gear, and shift fork (3) moves the 4th and 5th gears.

The neutral position is located between 1st and 2nd gears, and the neutral stopper mechanism is located on the left side of the shift drum.

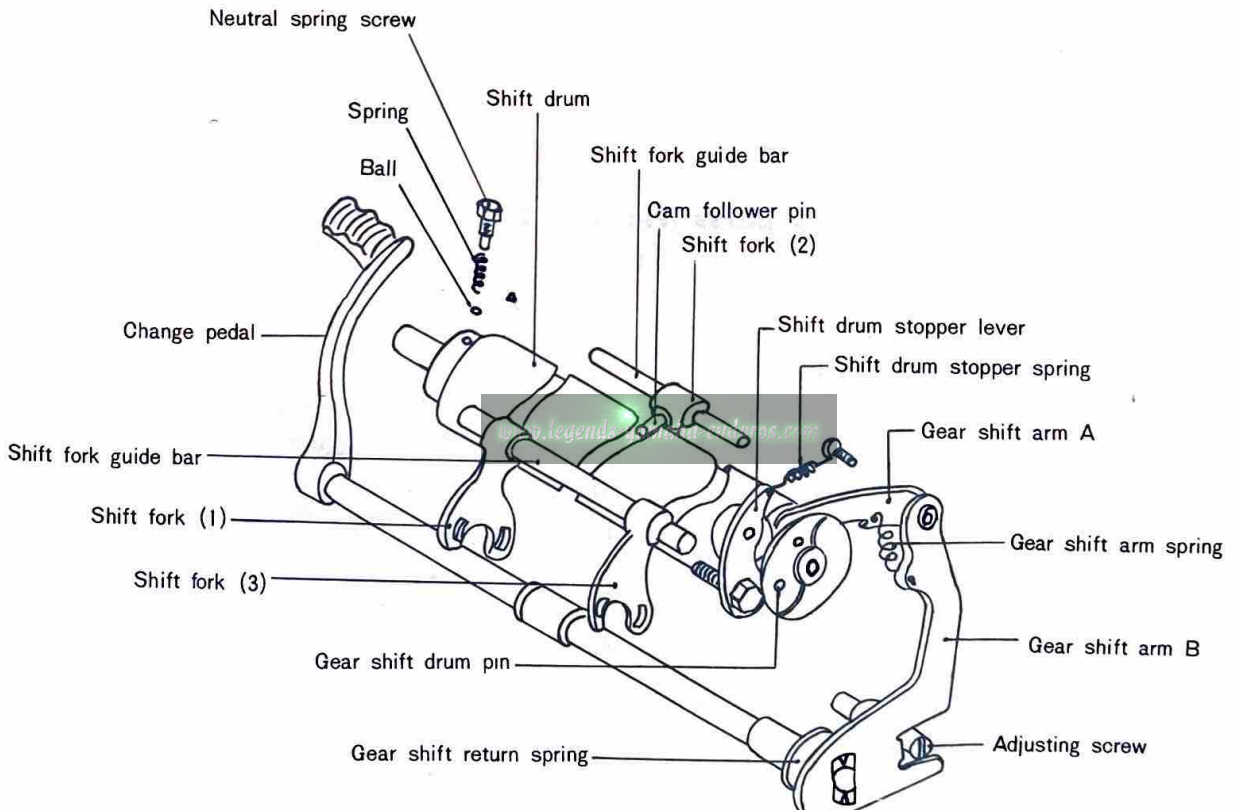

Fig. IV-12-1

## A. Removing the Change Axle Assembly

- 1) Remove the circlip and washer from the change axle (left side crank case).

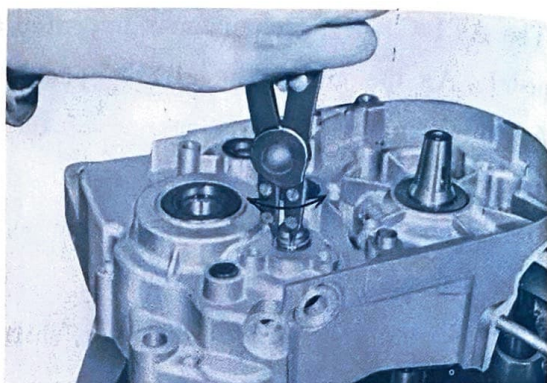

Fig. IV-12-2

- 2) Turn the engine over, right side up, and pull out the change shaft assembly.

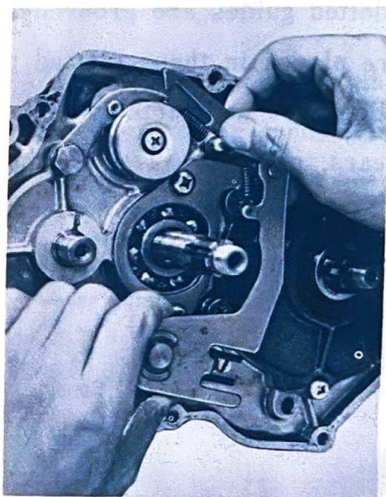

Fig. IV-12-3

## B. Checking the gear shift parts (Fig. IV-12-4)

Checking the Gear Shift Return Spring. A broken or fatigued gear shift return spring will impair the return action of the shifting mechanism.

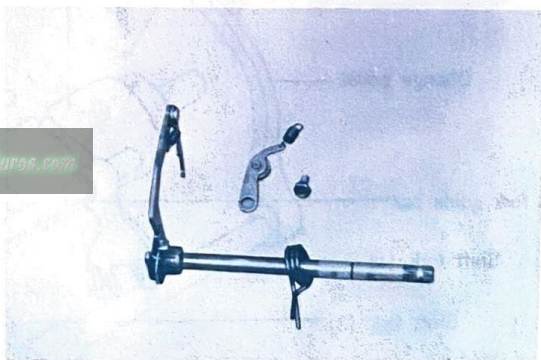

Fig. IV-12-4

### C. Adjusting the gear shift arm

Adjusting or correcting the travel of the gear shift arm to prevent improper shifting progression (excess feed or insufficient feed of the gear shift arm) is accomplished by turning the gear shift return spring stop screw (eccentric bolt) in or out. (Fig. IV-12-5)

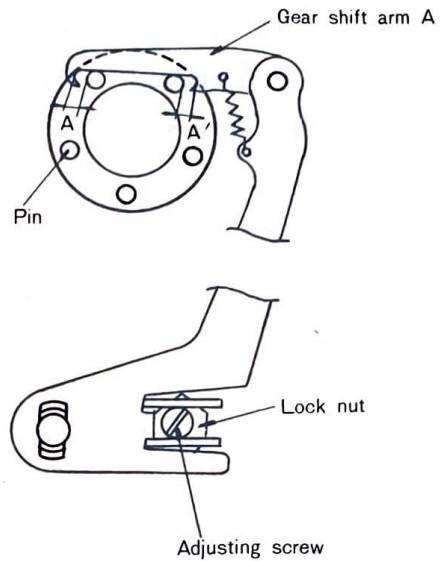

Fig. IV-12-5

## IV-13 Drive Sprocket

### A. Removal

- 1) Straighten the bent edge of the lock washer with a blunt-ended metal punch.

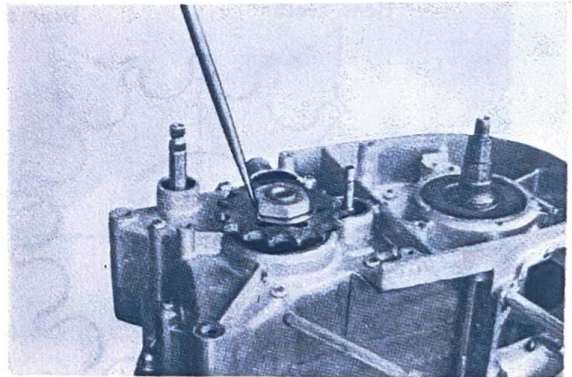

Fig. IV-13-1

- 2) Hold the drive sprocket with the flywheel magneto holding tool, and remove the sprocket nut. If the flywheel magneto holding tool is not available, shift the transmission to low gear, and fit a monkey wrench on the sprocket nut. Then tap the handle of the wrench with a hammer and the shock will loosen the nut.

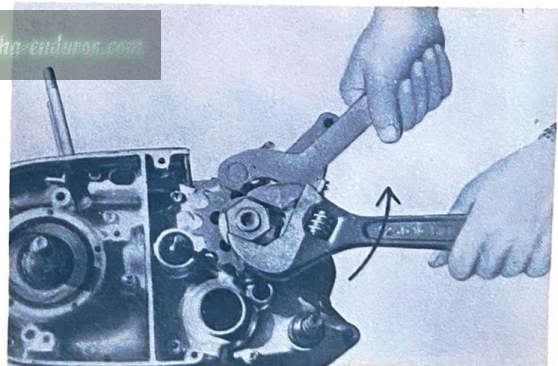

Fig. IV-13-2

- 3) Remove the distance collar with pliers. (When reinstalling distance collar, apply grease to the oil seal lip groove.)



Fig. IV-13-3

## B. Inspection

A worn drive sprocket will result in excessive chain noise, and shorten the life of the chain. Check the sprocket for worn teeth, and replace if they are worn.

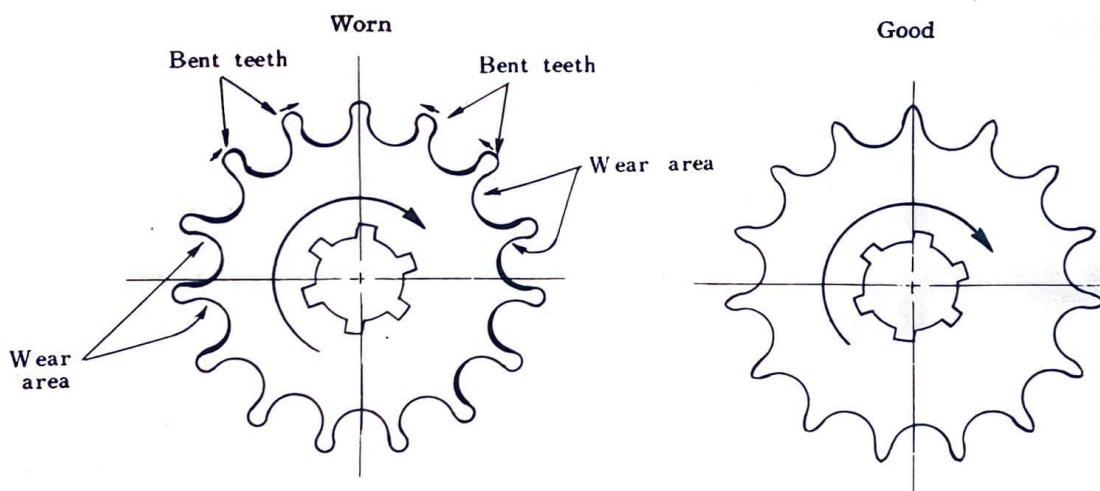

Fig. IV-13-4

[www.legends-yamaha-enduros.com](http://www.legends-yamaha-enduros.com)

---

## IV-14 Crankcase

### A. Separating

- 1) Remove neutral stopper.

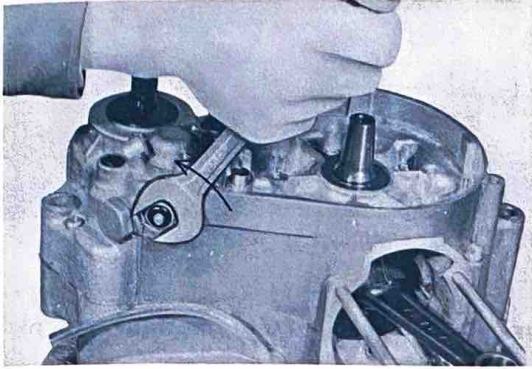

Fig. IV-14-1

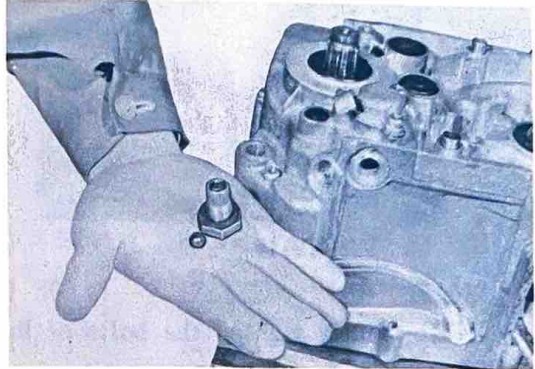

Fig. IV-14-2

- 2) Remove the change shift drum stopper lever and stopper spring.

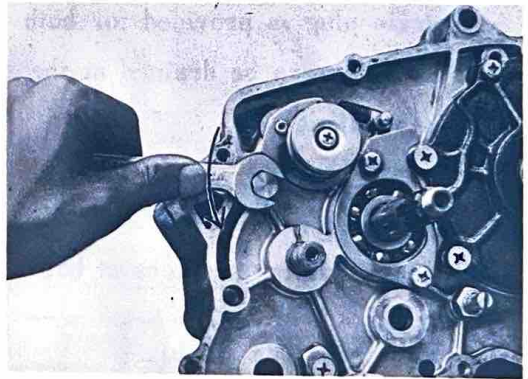

Fig. IV-14-3

- 3) Remove the pan head screws from the left crankcase.

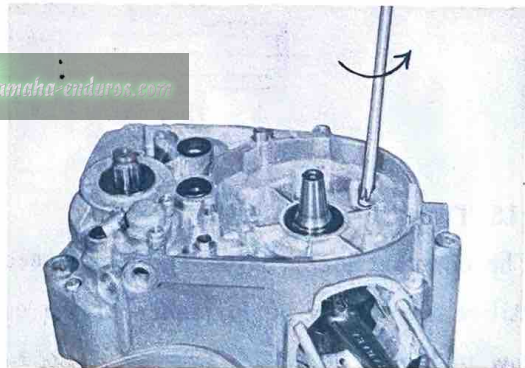

Fig. IV-14-4

- 4) Install the crankcase separating tool on the right crankcase. Divide the crankcase while alternately tapping the main axle and the crankcase with plastic tip hammer (IV-14-5, IV-14-6).

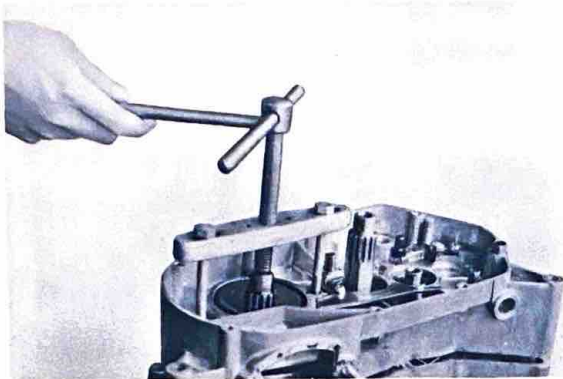

Fig. IV-14-5

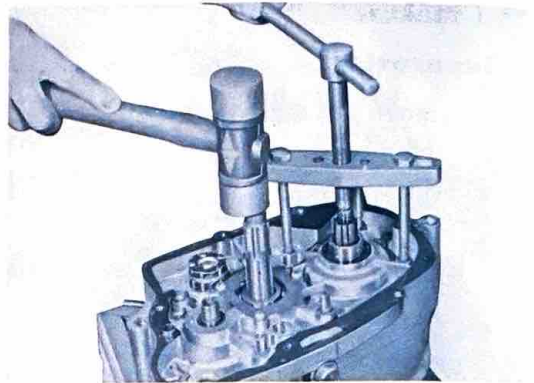

Fig. IV-14-6

**Note:** Fully tighten the bolts of the crankcase dividing tool, keeping the tool in a horizontal position.

The crankcase is designed to split into two halves, right and left. Only one drain plug is provided for both the transmission and clutch housings. Both housings can be drained at the same time by removing the drain plug.

### B. Reassembling

When reassembling the crankcase, be sure to apply YAMAHA BOND No.5 to the mating surfaces of both halves.

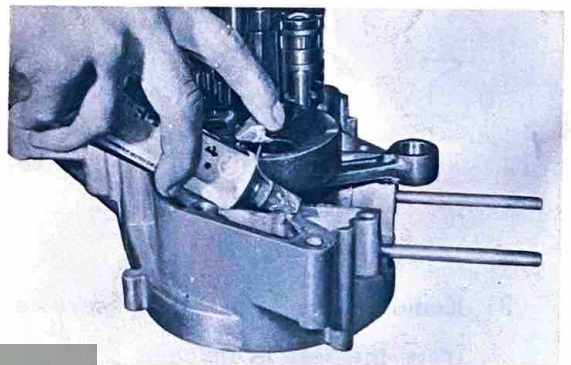

Fig. IV-14-7

[www.legends-yamaha-enduros.com](http://www.legends-yamaha-enduros.com)

### IV-15 Transmission Assembly

The constant mesh, wide ratio, 5-speed transmission makes it possible to fully utilize the steady performance of the engine throughout the entire speed range from low to high.

For layout of the transmission and related parts, refer to Fig. IV-15-1 and 2. The primary reduction ratio is  $74/19=3.894$ . Therefore the total reduction ratios will be; Primary reduction ratio  $\times$  Transmission gear reduction  $\times$  Secondary reduction ratio = Total reduction ratio.

Primary Reduction Ratio.....74/19=3.894				
Secondary Reduction Ratio..... $\left\{ \begin{array}{l} 45/14=3.214(\text{AT1-C}) \\ 45/15=3.000(\text{AT1-MX}) \end{array} \right.$				
	Transmission Gear Reduction Ratio		Total Reduction Ratio	
	AT1-C	AT1-MX	AT1-C	AT1-MX
1st	$35/11=3.182$	$34/12=2.833$	39.824	33.095
2nd	$30/15=2.000$	$30/16=1.875$	25.031	21.904
3rd	$26/19=1.368$	$26/19=1.368$	17.121	15.981
4th	$23/23=1.000$	$24/22=1.091$	12.515	12.745
5th	$20/25=0.800$	$22/23=0.957$	10.012	11.180

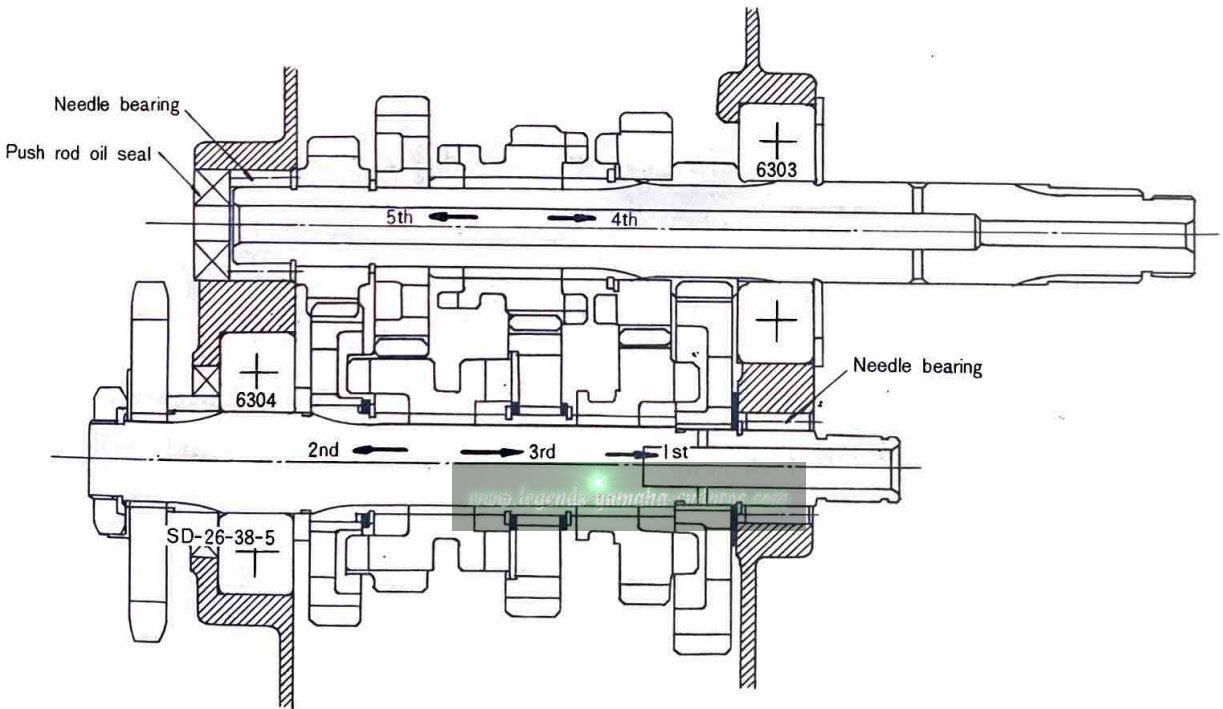

Fig. IV-15-1

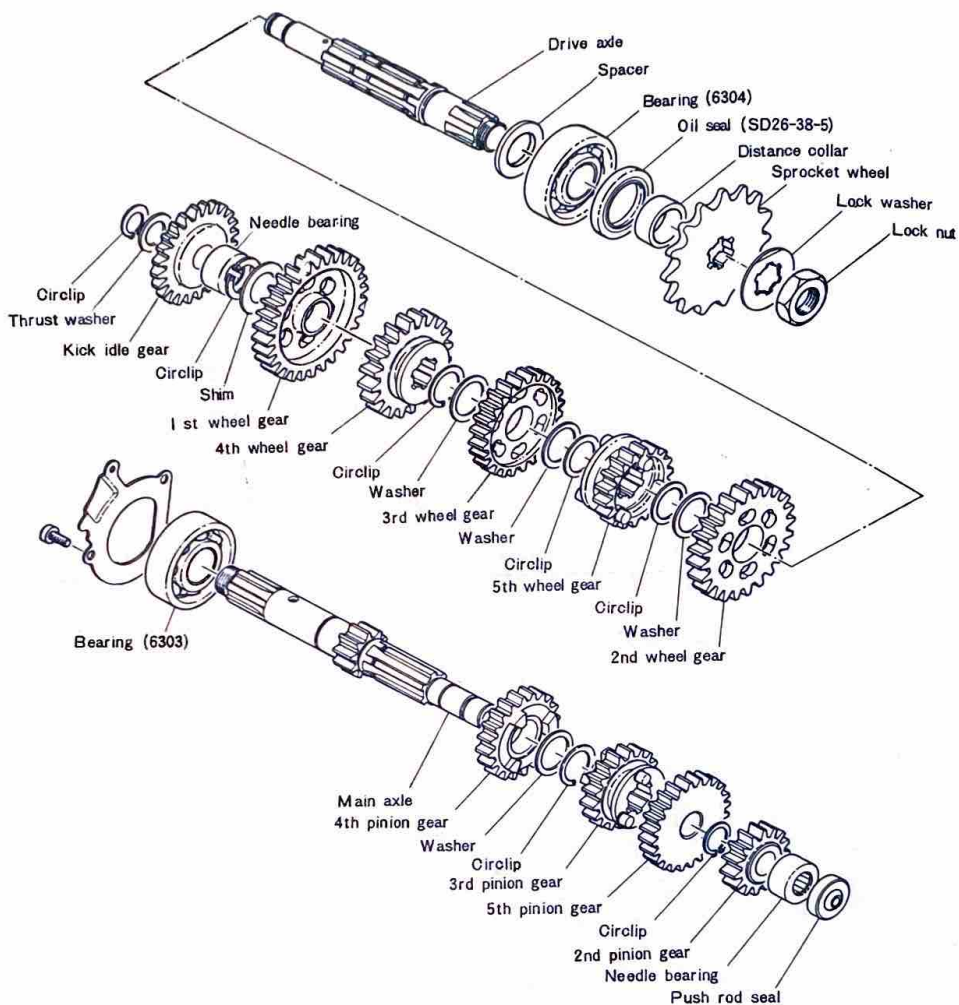

Fig. IV-15-2

**A. Removal**

- 1) Pull out the two shift fork guide bars.

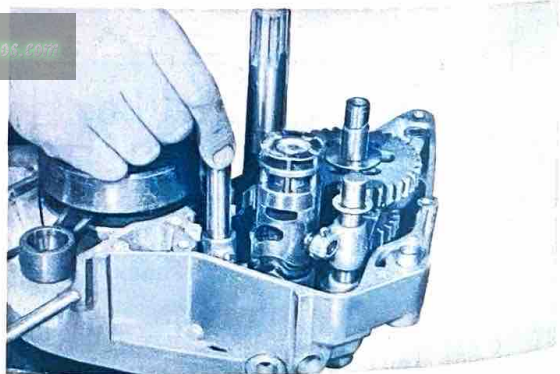

Fig. IV-15-3

- 2) Remove both the transmission assembly and the shift forks from the crankcase, while tapping the drive shaft end with a plastic-tip hammer. (Fig. IV-15-4)



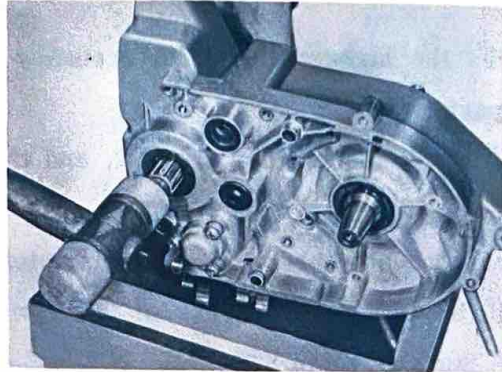

Fig. IV-15-4

- 3) To remove the shift drum, remove the shift cam blind plug set screw on the left side of the crankcase, and remove the shift cam blind plug. Then remove the circlip and washer from the shift drum, and the shift drum can be pulled out from the opposite side.

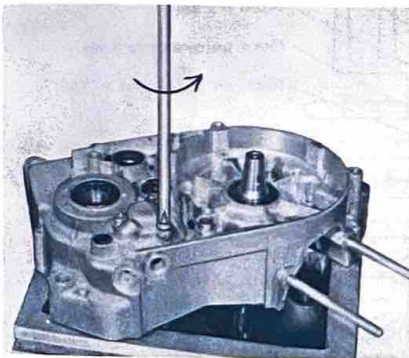

Fig. IV-15-5

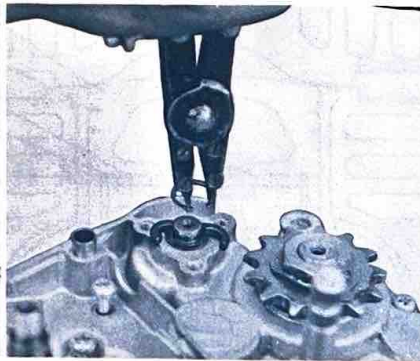

Fig. IV-15-6

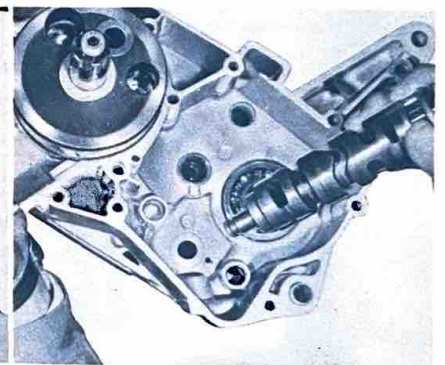

Fig. IV-15-7

## B. Reinstallation

Reinstall the transmission and shifter as a unit in the left crankcase half after they are sub-assembled. They cannot be installed separately. The transmission unit must be in neutral during installation.

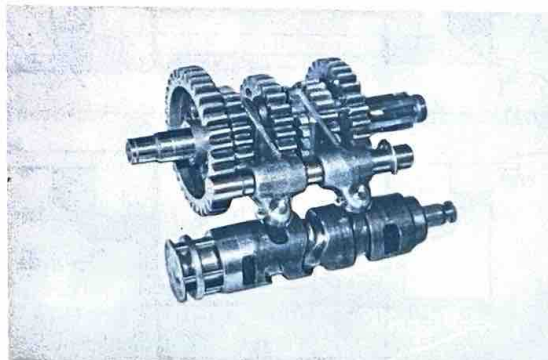

Fig. IV-15-8

## IV-16 Crankshaft

The crankshaft requires the highest degree of accuracy in engineering and servicing of all the engine parts.

The crankshaft is also more susceptible to wear, and therefore, it must be handled with special care.

To increase the inertia force of the crank, the diameter of the left crankshaft is increased to 25 mm. (0.98 in.) the thickness of the flywheel to 23.5 mm. (0.93 in.) and its diameter to 87 mm. (3.43 in.)

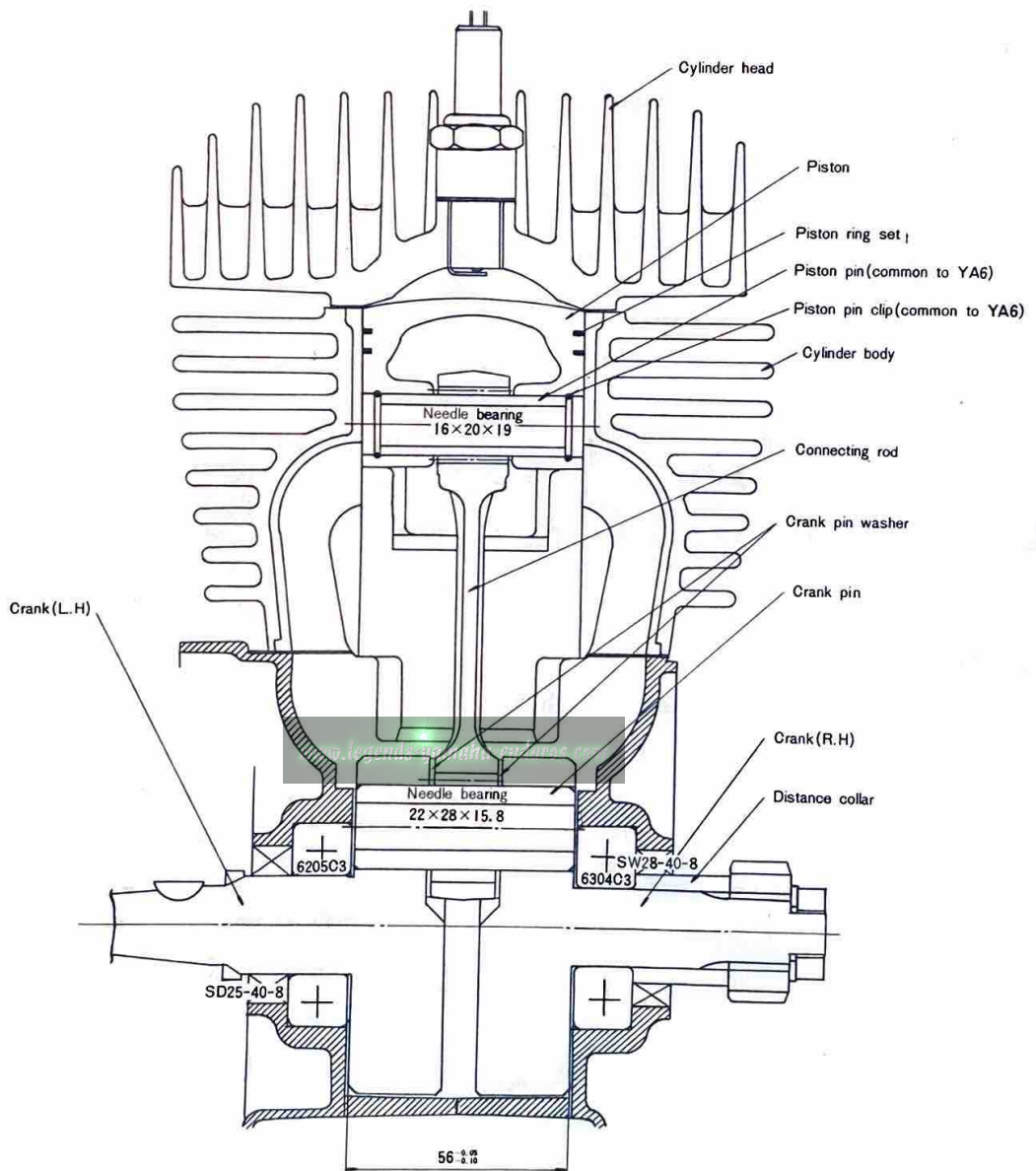
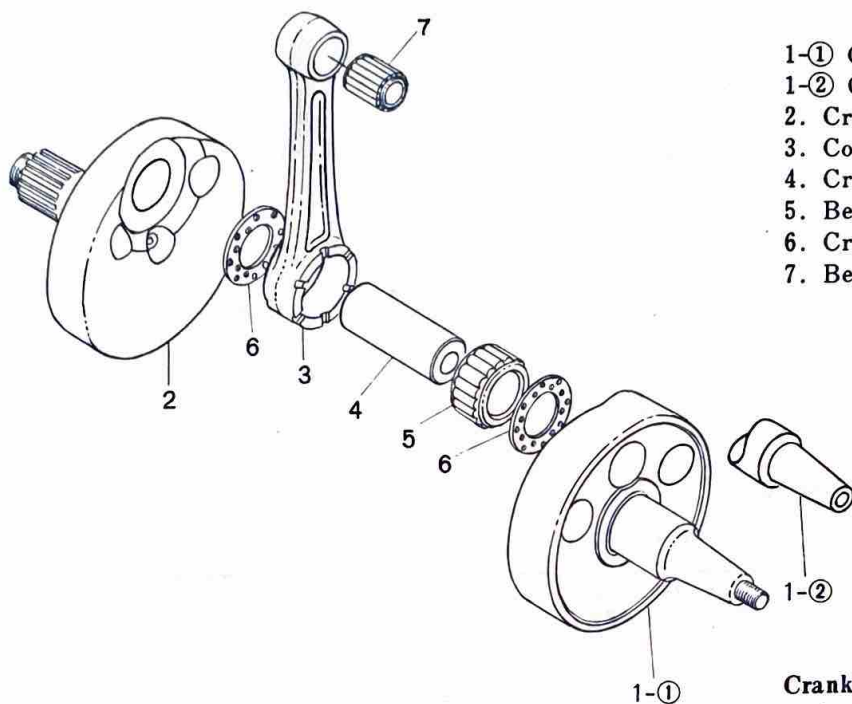

Fig. IV-16-1



- 1-① Crank (L.H.).....AT1-MX
- 1-② Crank (L.H.).....AT1-C
- 2. Crank (R.H.)
- 3. Connecting rod
- 4. Crank pin
- 5. Bearing
- 6. Crank pin washer
- 7. Bearing

Fig. IV-16-2

Crankshaft component parts

### A. Removing the Crankshaft Assembly

Remove the crankshaft assembly with the crankcase separating tool.

**Note:** Fully tighten the bolts of the crankcase dividing tool, and keep the tool in parallel with the crankcase surface.

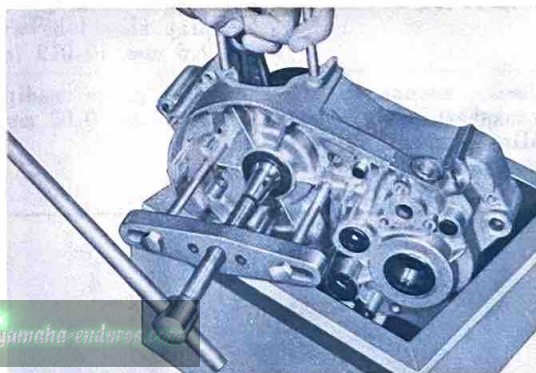

Fig. IV-16-3

### B. Installing the Crankshaft Assembly

Install the crankshaft assembly by using the crankshaft setting tool and the crank fitting spacer.

Hold the connecting rod at top dead center with one hand while turning the handle of the setting tool with the other.

**Note:** 1) The crankshaft setting tool is same as those used for YL1(AT1-C) and DT1(AT1-MX).

- 2) The crank fitting spacer is required because the crankshaft is larger in diameter.

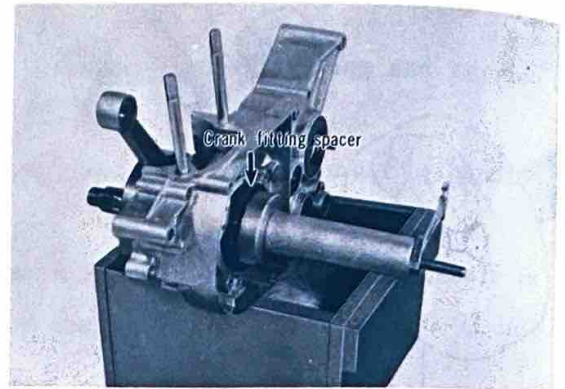

Fig. IV-16-4

### C. Inspection and Servicing

- 1) Checking the crankshaft components

Check connecting rod axial play at small end (to determine the amount of wear of crank pin and bearing at large end) Fig. IV-16-5)	Small end play should not exceed 2 mm. (0.078 in.)	If small end play exceeds 2 mm, disassemble the crank shaft, check connecting rod crank pin and large end bearing. Replace defective parts. Small end play after reassembly should be within 0.8-1.0 mm. (0.031~0.04 in.)
Check the connecting rod for axial play at large end. (Fig. IV-16-6)	Move the connecting rod to one side and insert a feeler gauge. Large end axial play should be within 0.4-0.5 mm. (0.019 in.)	If excessive axial play is present, (0.6 mm or more) disassemble the crankshaft and replace any worn parts.
Check accuracy of the crankshaft ass'y runout. (Misalignment of parts of the crankshaft) (Fig. IV-16-7)	Dial gauge readings should be within 0.03 mm. (0.0012 in.)	Correct any misalignment by tapping the flywheel with a brass hammer and by using a wedge.



Fig. IV-16-5



Fig. IV-16-6

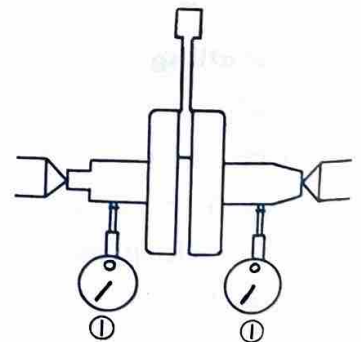

Fig. IV-16-7

## IV-17 Bearings and Oil Seals

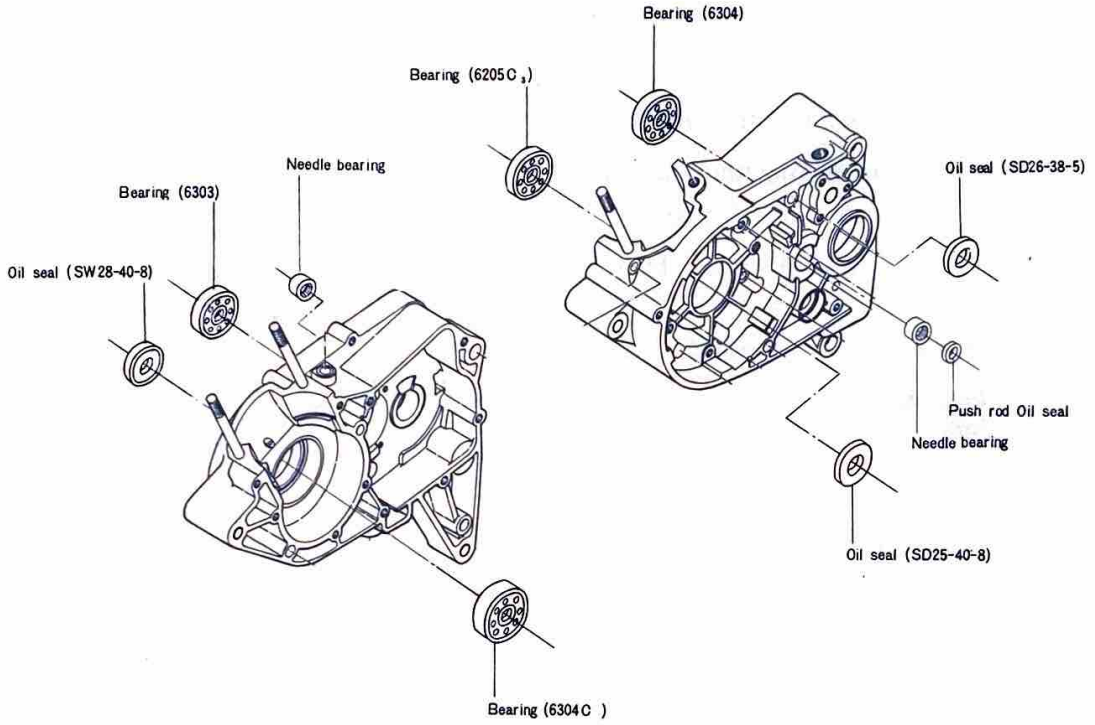

Fig. IV-17-1

---

## 1. Removal and Installation

### 1) Removal

- a. Pry the oil seals out of place with a slot head screwdriver. Always replace the oil seals when overhauling the engine.

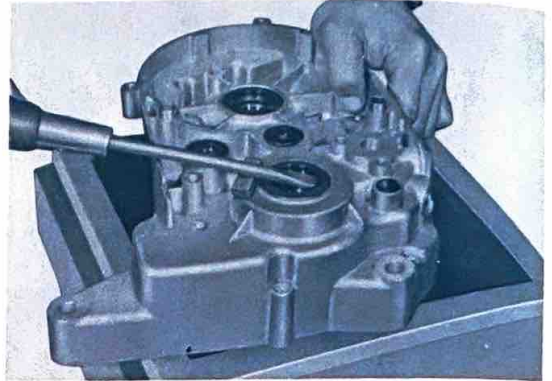

Fig. IV-17-2

- b. Drive out the bearing with a bearing tool.

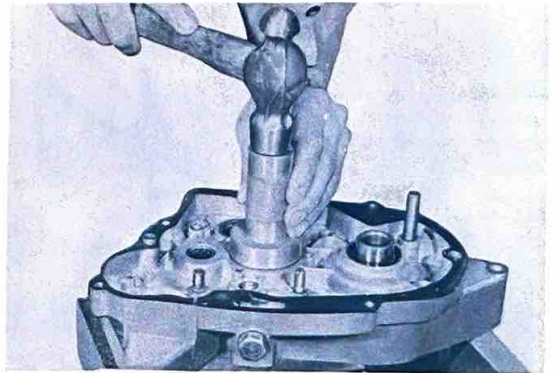

Fig. IV-17-3

### 2) Installation

Install bearings and oil seals with their stamped manufacturer's marks or numerals facing outward. (In other words, the stamped letters must be on the exposed view side.)

When installing bearings, pack them with grease.

[www.legends-yamaha-enduros.com](http://www.legends-yamaha-enduros.com)

## IV-18 Carburetor

The standard AT1-C is equipped with a VM24SH 24 mm. carburetor that is equipped with a built-in starter jet.

Note that the AT1-MX is equipped with VM26SH type carburetor for better performance.

The carburetor is bolted to a 20 mm. thick bakelite insulator that is located between the carburetor and cylinder. This insulator provides more than adequate heat insulation. The carburetor floats have been specially designed to keep the float level from fluctuating due to vibration or shock. The main jet is installed in such a manner to provide quick and easy replacement from the outside by merely removing the jet holder on the bottom left side of the carburetor float bowl.

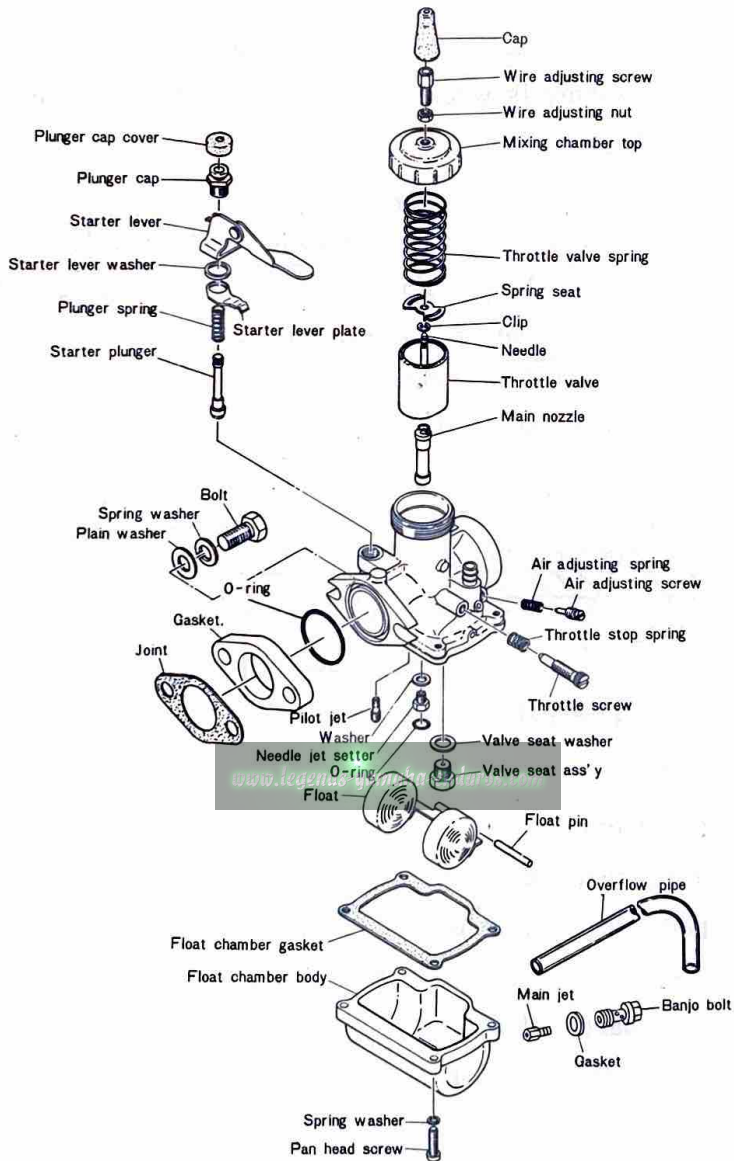

Fig. IV-18-1

Explosion diagram of carburetor

## A. Checking the Carburetor

### 1) Float

Remove the float and shake it to check if gasoline is inside. If fuel leaks into the float while the engine is running, the float chamber fuel level will rise and make the fuel mixture too rich. Replace the float if it is deformed or leaking.

### 2) Float valve

Replace the float valve if its seating end is worn with a step or if it is scratched. Check the float valve spring for fatigue. Depress the float valve with your finger, and make sure that it properly seats against the valve seat. If the float valve spring is weakened, fuel will overflow, flooding the float chamber while the gas is on.

### 3) Overflowing

If fuel overflows, check the carburetor as described in 1) and 2) above. If neither 1) nor 2) cures the overflowing, it may be caused by dirt or dust in the fuel preventing the float valve from seating properly. If any dirt or dust is found, clean the carburetor, petcock and gas tank.

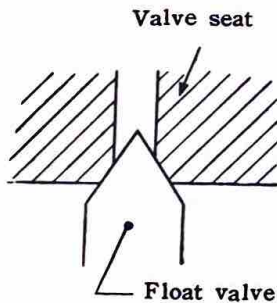

Fig. IV-18-2

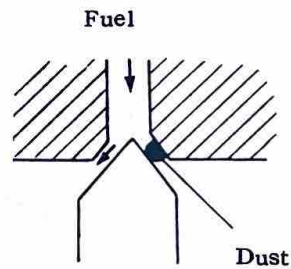

Fig. IV-18-3

### 4) Cleaning the carburetor

Disassemble the carburetor, and wash all its parts in a suitable solvent.

Then blow all the parts off with compressed air. All jets and another delicate parts should be cleaned by blowing compressed air through them.

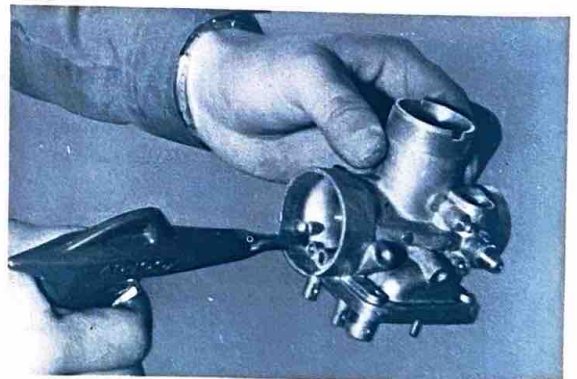

Fig. IV-18-4



## B. Float Level Adjustment

The carburetor float level is checked by the Yamaha factory during assembly and testing. But rough riding, worn needle valve, or bent float arm can cause the float level to fluctuate. If the float level raises, this will cause a rich fuel/air mixture that can cause poor performance and spark plug fouling. If the float level decreases, this can cause a lean fuel/air mixture that can result in engine damage. If the machine is subjected to continuous rough riding or many miles of travel, the float level should be checked and set regularly and in the following manner.

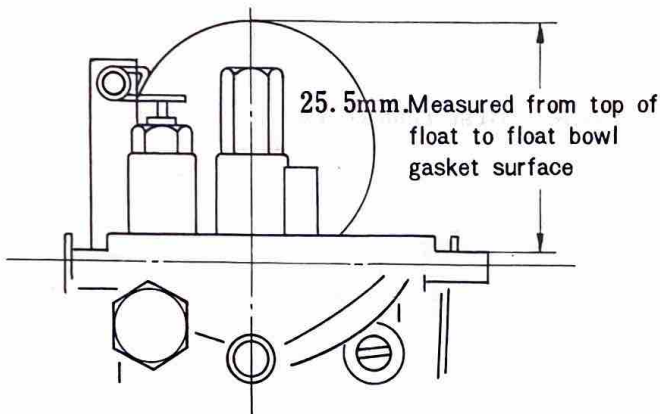

Fig. IV-18-5

- 1) Remove the float chamber body, and turn over the mixing body. Let the float arm rest on the needle valve without compressing the spring.
- 2) Then measure the distance from the top of the float to the float bowl gasket surface.  
[www.legends-yamaha-enduros.com](http://www.legends-yamaha-enduros.com)  
Standard measurement 25.5 mm
- 3) When the distance measures less than the recommended distance, bend the tang up. If it is greater, bend the tang down. (with carburetor body up side down.)

## C. Idle Mixture-Idle Speed Adjustments

The idle Mixture adjustment should be set exactly to factory specifications. First, turn the air screw in until it lightly seats then back it out  $1\frac{1}{2}$  turns (both AT1-C and AT1-MX). Next, adjust the throttle stop so that the engine idles at 1200-1300 rpm.

## D. Carburetor Setting Table

Name of Parts	Abbreviation	Specifications	
		AT1-C	AT1-MX & GYT
Main jet	M. J	#150	#190
Needle jet	N. J	N-8	0-2
Jet needle	J. N	4D3-3 stages	4F15-2 stages
Pilot jet	P. J	#30	#30
Starter jet	G. S	#40	#40
Throttle valve cut away	C. A	2.0	1.5
Air screw setting	A. S	1½	1½
Idling speed	—	1200~1300 rpm	1200~1300 rpm
I dent. Mark	—	248A2	248M2

## IV-19 Air Cleaner

### A. Removal

To remove the air filter, first remove two oil tank fitting bolts. Next, remove the air cleaner case cap fitting spring and air cleaner case cap. Then the element can be removed.

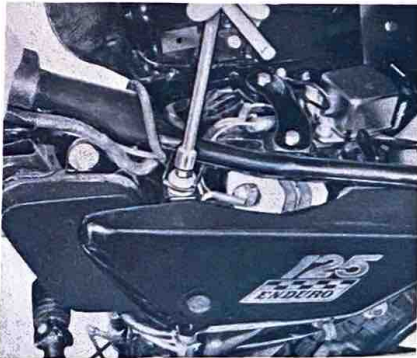

Fig. IV-19-1

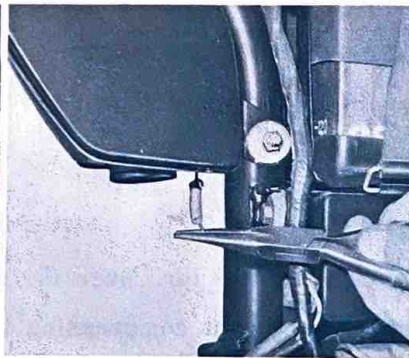

Fig. IV-19-2

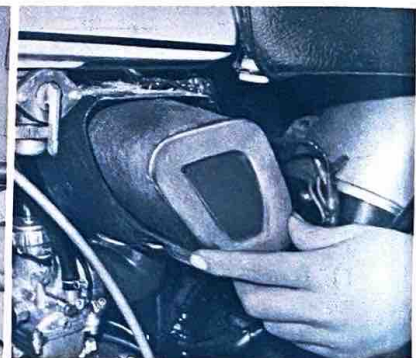

Fig. IV-19-3

### B. Cleaning

Wash the foam filter thoroughly in solvent until all dirt has been removed. Squeeze all the solvent out. Pour oil onto the filter (any grade of 20 or 30 wt), work it completely in, and then squeeze out the surplus oil. The filter should be completely impregnated with oil, but not "dripping" with it.

[www.legends-yamaha-enduros.com](http://www.legends-yamaha-enduros.com)



Fig. IV-19-4

## Chapter V Chassis

The Yamaha ATI-C has been designed for versatility and a combination of uses. It is equipped with all necessary street legal equipment to insure pleasurable road or street riding. This machine can be quickly converted to a competition machine and therefore has been engineered to have a minimum weight factor. Yet with the reduction in weight; rigidity, strength, and safety have been incorporated in the design of the frame to provide an unexcelled competition machine.

### V-1 Front Wheel

The 18" front wheel is equipped standard with a 3.00-18" Trials Universal tire,

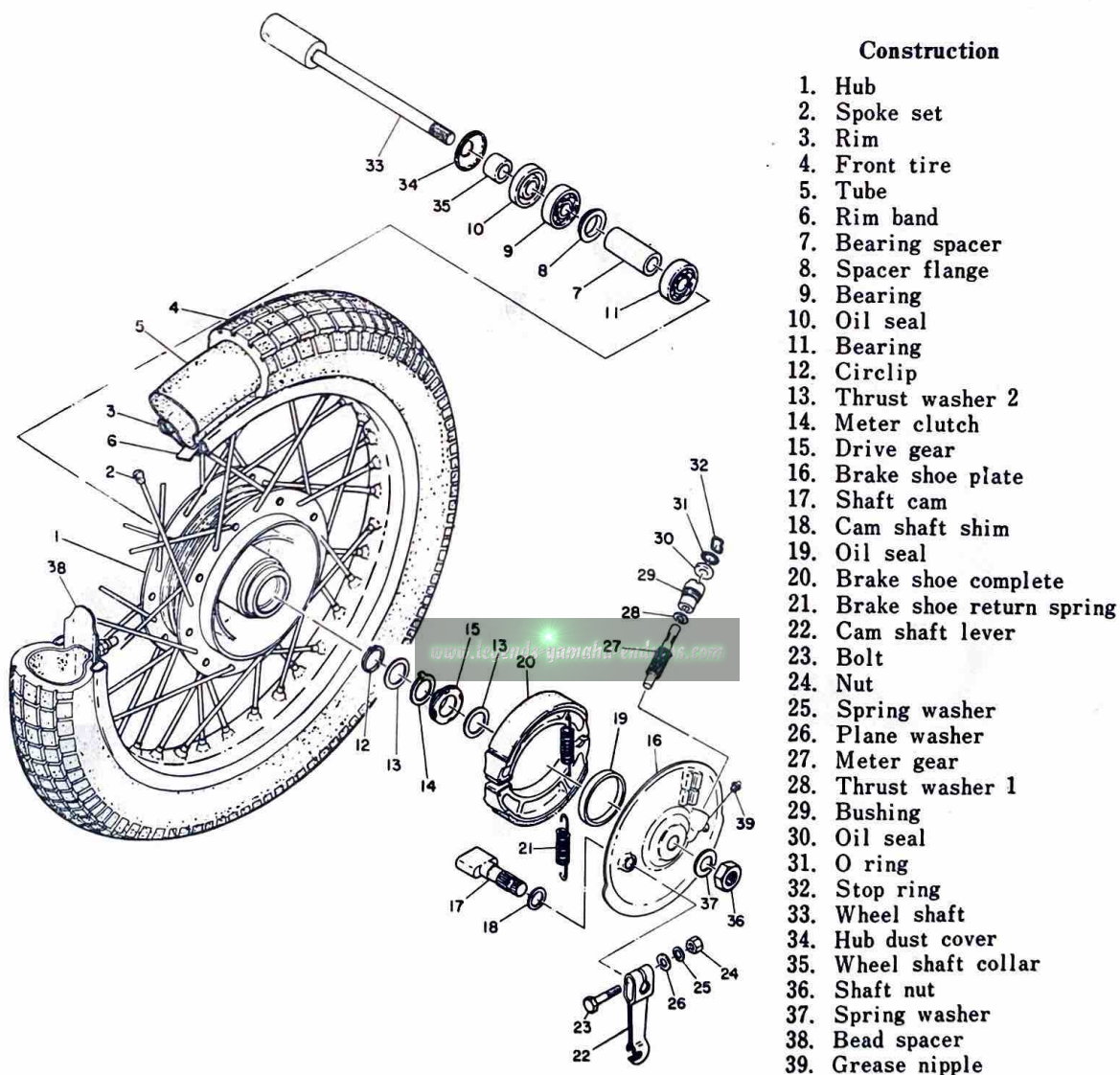

Fig. V-1-1

---

This tire gives the rider assurance of maximum performance and safety for both road riding and trail riding. The front wheel brake size is 110 mm.×25 mm. (4.33×0.98 in.) A labyrinth seal is installed between the wheel hub and brake plate to provide a seal against dust and water.

### A. Removal

- 1) Disconnect the brake cable at the front brake lever.

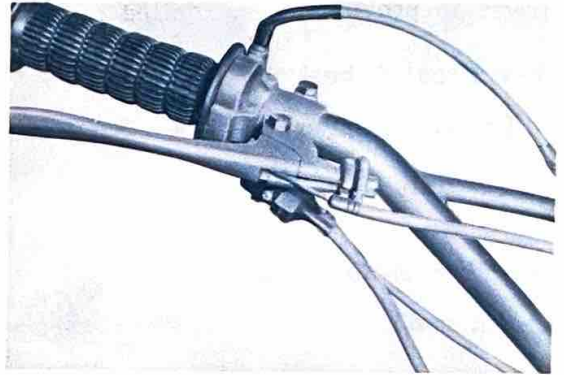

Fig. V-1-2

- 2) Disconnect both the brake cable and speedometer cable from the front wheel hub plate.

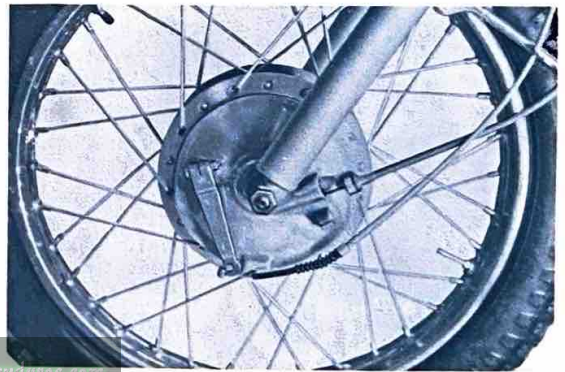

Fig. V-1-3

- 3) Loosen the front wheel axle lock bolt.

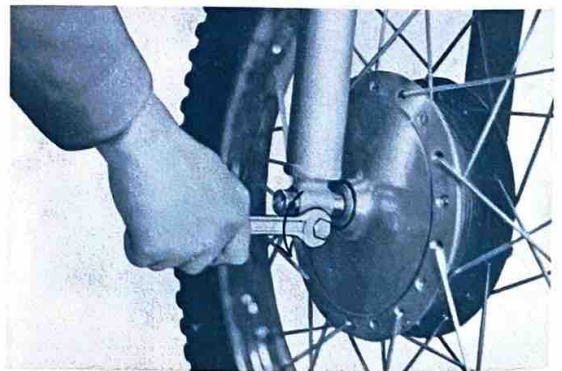

Fig. V-1-4

- 
- 4) Remove the front wheel nut.

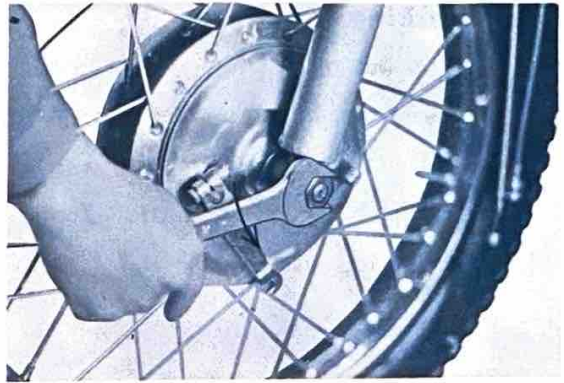

Fig. V-1-5

- 5) Remove the front wheel axle by simultaneously twisting and pulling out on the axle.



Fig. V-1-6

- 6) Raise the front of the machine and set it on a box. Then remove the wheel assembly.

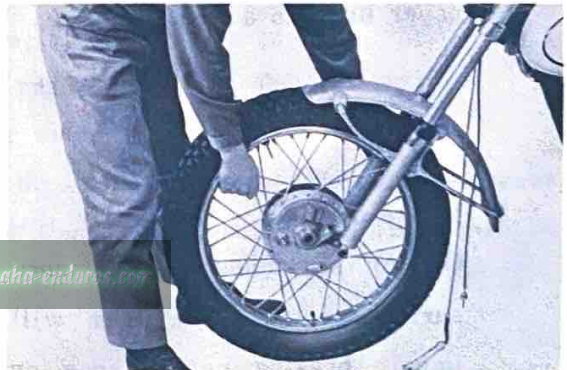

Fig. V-1-7

## B. Checking

### 1) Run out of the rim

As shown in Fig. V-1-8, measure the runout of the rim with a dial gauge. Run out limits : 2 mm. (0.07 in.) or less.

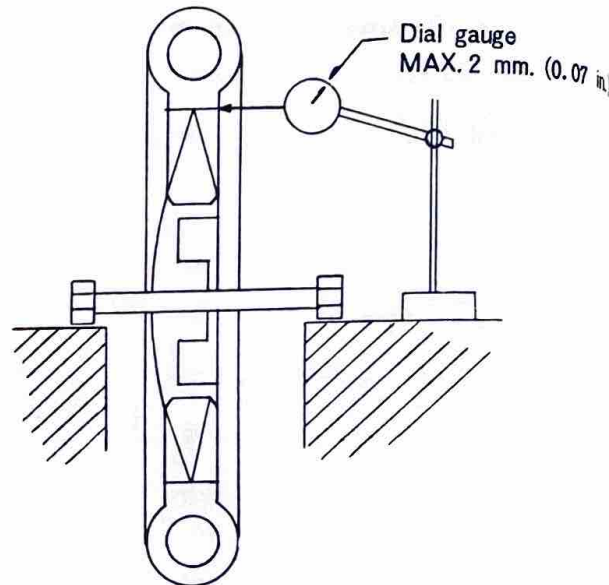

Fig. V-1-8

### 2) Brake shoe

Measure the outside diameter of the brake shoe with slide calipers. If it measures less than 104 mm. (4.09 in.), replace it. Smooth out a rough shoe surface with sandpaper or with a file.

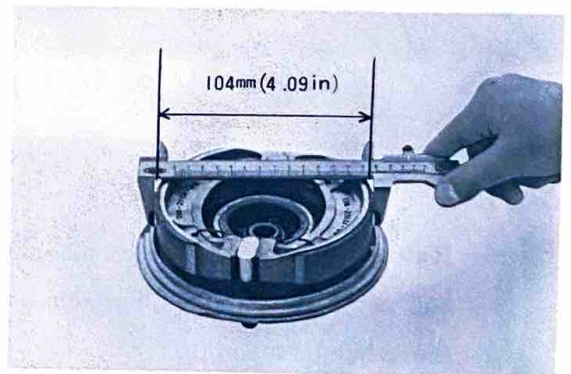

Fig. V-1-9

### 3) Brake drum

Oil or scratches on the inner surface of the brake drum will impair braking performance or result in abnormal noises. Clean or smooth out the surface with a rag soaked in lacquer thinner or with sandpaper.

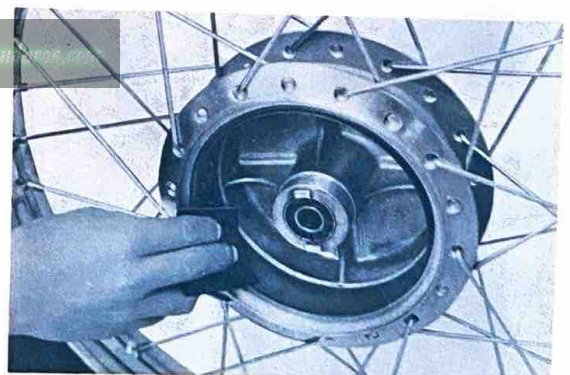

Fig. V-1-10

- ### 4) Check the spokes. If they are loose or bent, replace or tighten them. If the machine is ridden in rough country often, or raced, the spokes should be checked regularly.

- 5) Repairing the brake shoe  
If the brake shoe has uneven contact with the brake drum or scratches, smooth out the surface with sandpaper or hand file.



Fig. V-1-11

- 6) If the tire is excessively worn, replace it.
- 7) Regularly check the tires for damage.
- 8) If the bearings allow excessive play in the wheel or if it does not turn smoothly, replace the bearing.
- 9) Replace a bent or damaged front wheel axle.
- 10) If the tooth surface of the helical speedometer drive gear is excessively worn, replace it.
- 11) Check the lips of the seals for damage or warpage. Replace if necessary.

### Replacing the Wheel Bearing

- a. First clean the outside of the wheel hub.
- b. Insert the bent end of the special tool (as shown in Fig. V-1-13) into the hole located in the center of the bearing spacer, and drive the spacer out from the hub by tapping the other end of the special tool with a hammer. (Both bearing spacer and spacer flange can easily be removed.)
- c. Then push out the bearing on the other side.
- d. To install the wheel bearing, reverse the above sequence. Be sure to grease the bearing before installation and use the bearing fitting tool (furnished by Yamaha.).

[www.legends-yamaha-enduros.com](http://www.legends-yamaha-enduros.com)

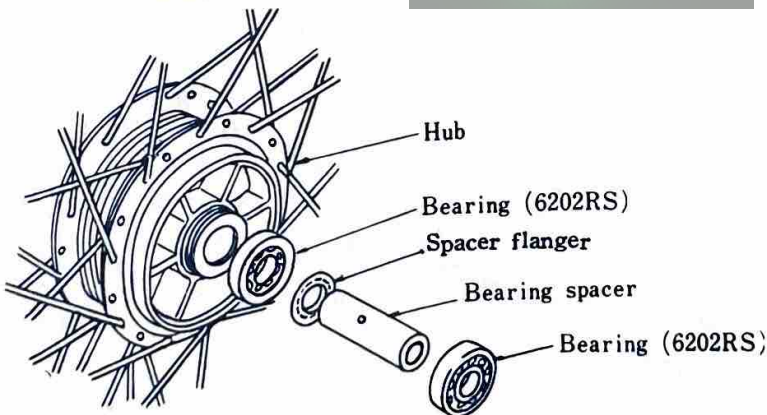
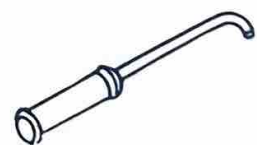

Fig. V-1-12



Insert the bent end of the special tool into the hole located in the center of the bearing spacer.

Fig. V-1-13

## V-2 Rear Wheel

The rear wheel is 18-in. size, and the rear tire is the 3.25-18 Trials Universal. The single leading shoe type brake is of the 130 mm. × 28 mm. (5.12 × 1.10 in.) size. A labyrinth seal between the wheel hub and the brake plate is provided to prevent water and dust leakage. The brake tension bar is of link design to minimize the shifting of the brake cam lever position when the rear swing arm is moving up and down. The rear fender is steel, and rubber mounted on the frame. It is also wide enough to protect the engine unit from dust and water. Note that the AT1-MX uses 3.50-18" trials universal tires.

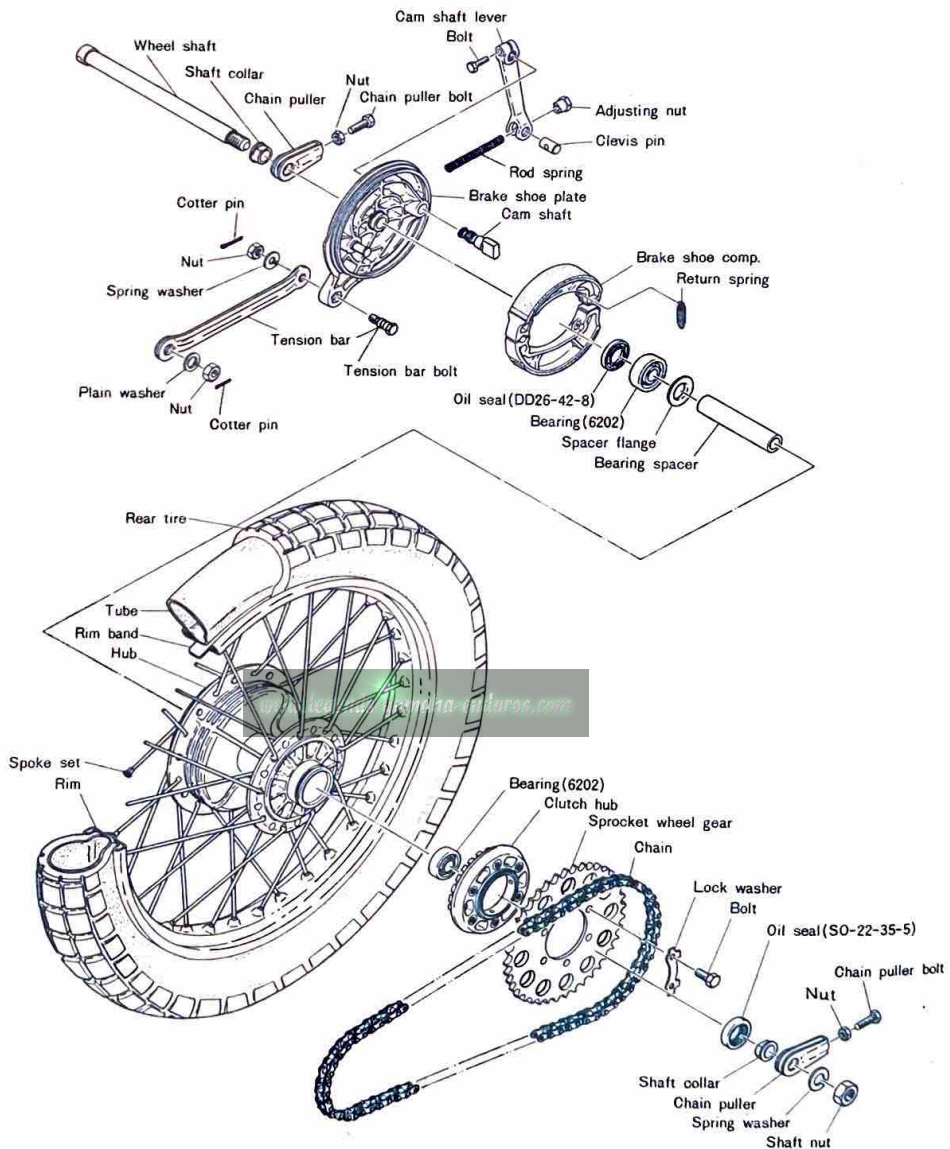

Fig. V-2-1 Rear Wheel Construction



---

**A. Removal**

- 1) Remove the tension bar and brake rod from the rear shoe plate.

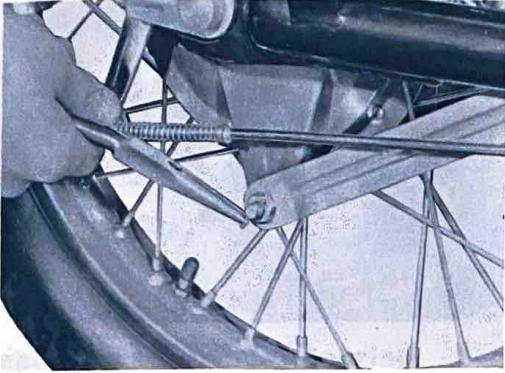

Fig. V-2-2

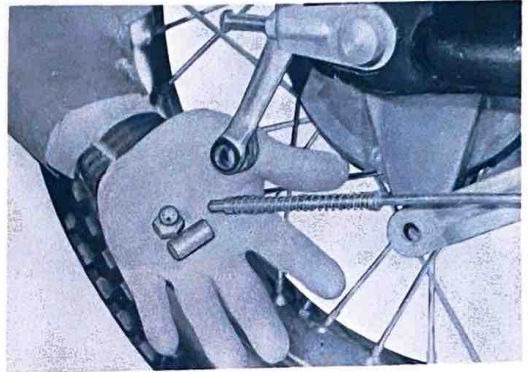

Fig. V-2-3

- 2) Loosen the chain tension adjusting nuts and bolts on both right and left sides.

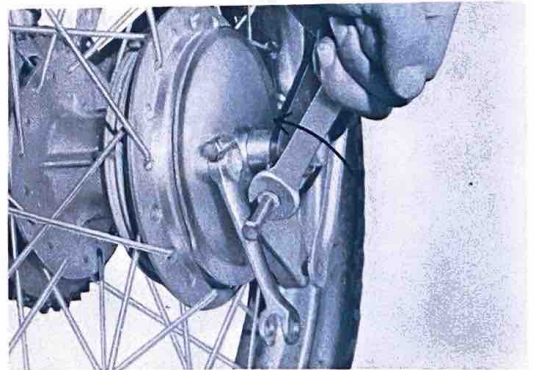

Fig. V-2-4

- 3) Remove the rear wheel shaft nut.

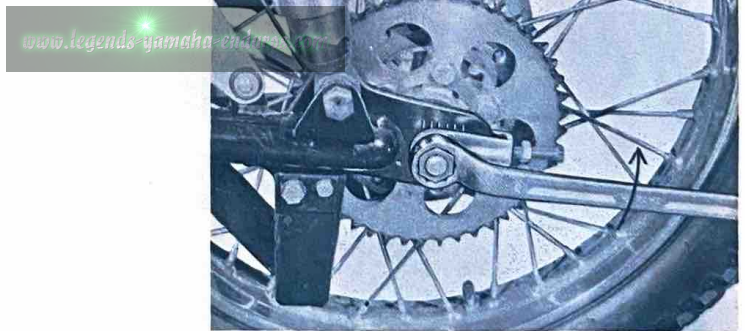

Fig. V-2-5

- 
- 4) Pull out the rear wheel shaft by striking it with a plastic tip hammer.

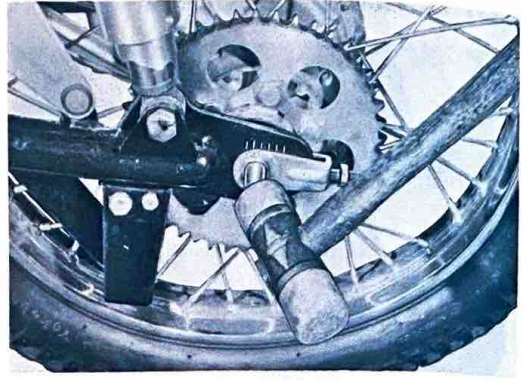

Fig. V-2-6

- 5) Remove the right-hand chain adjuster and distance collar.

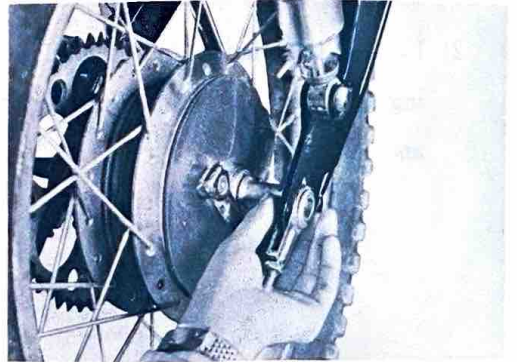

Fig. V-2-7

- 6) Remove the rear brake plate.

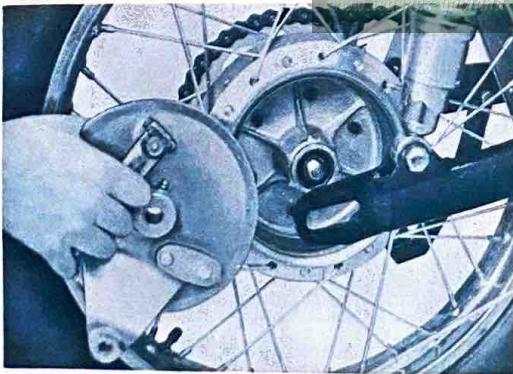

Fig. V-2-8

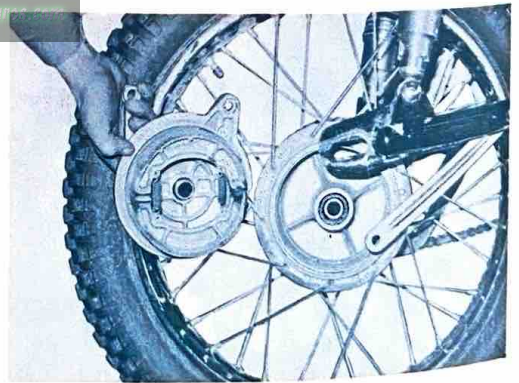

Fig. V-2-9

- 
- 7) Lean the machine to the left and remove the rear wheel assembly.

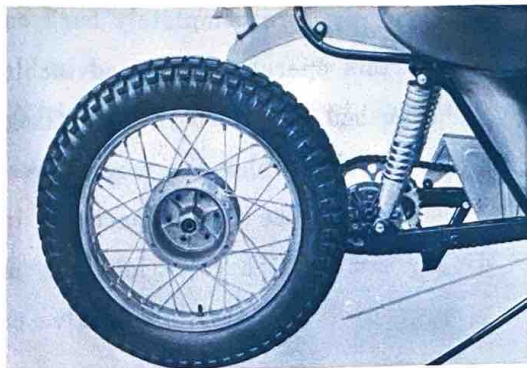

Fig. V-2-10

### **Replacing the Wheel Bearing**

Replace the wheel bearing in the same way as the front wheel bearing.

### **Replacing Tires**

#### **1) Removal**

- a. Remove the valve cap and lock nut (12 mm.) from the tire valve, and deflate the tire.  
www.legends-yamaha-enduros.com
- b. Remove the tire from the wheel rim by the use of two tire levers. (Exercise care to avoid damaging the inner tube with the levers.)

It is noted that to remove the inner tube, one side of the tire should be pried out of the wheel rim.

#### **2) Installation**

- a. Insert the tube between the tire and the wheel rim, and inflate the tube. Be sure that the valve stem is directed toward the wheel shaft. At this time the tire is still halfway off the rim.

- 
- b. Force the tire completely back on the wheel rim by the use of tire levers. For this operation, it is advisable that the bead on the other side of the tire be pushed in toward the rim flange.
  - c. To avoid pinching the tube between the tire and the rim, tap the tire with a hammer as the tire is partially inflated.
  - d. Tighten the tire valve lock nut, and inflate the tire to the recommended pressure, then install the valve cap.

## **B. Inspection**

- 1) Run out of the rim

Check the rim for run out in the same way as the front wheel. Maximum limit of runout.....2 mm. (0.07 in.) or less.

- 2) Brake shoe

Check the brake shoe in the same way as the front wheel. Minimum limit .....124 mm. ( 4.9 in.)

- 3) Brake drum

Check the brake drum in the same way as the front wheel.

- 4) The spokes are measured in the same way as the front wheel. A loose spoke should be tightened.
- 5) If the bearing has excessive play or it does not turn smoothly, replace it.
- 6) If the tire or the pattern is worn out, replace the tire.
- 7) If the lip of the oil seal is damaged or warped, replace it.

---

## V-3 Rear Wheel Sprocket

### A. Checking and Adjustment

The rear wheel sprocket is installed on the clutch hub. To replace the sprocket, take the following steps.

#### 1) Removing the sprocket

- a. Bend the lock washer ears flat.



Fig. V-3-3

- b. Remove the sprocket mounting bolts.

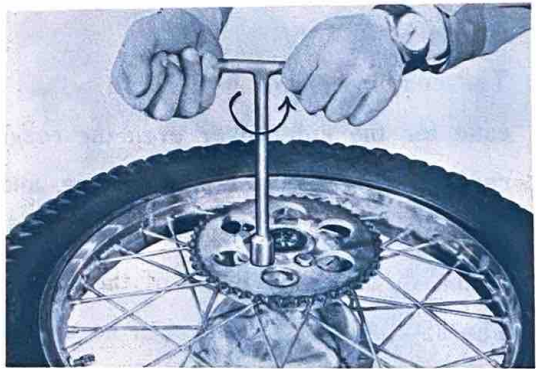

Fig. V-3-4

#### 2) Checking

Check the lock washer and hexagonal bolt for breakage and damage. If the lock washer is not bent over the hexagonal bolt head, or is broken, or if the bolt is loose, the sprocket can come loose. Make sure that both lock washers and the mounting bolts are tight.

[www.legends-yamaha-enduros.com](http://www.legends-yamaha-enduros.com)

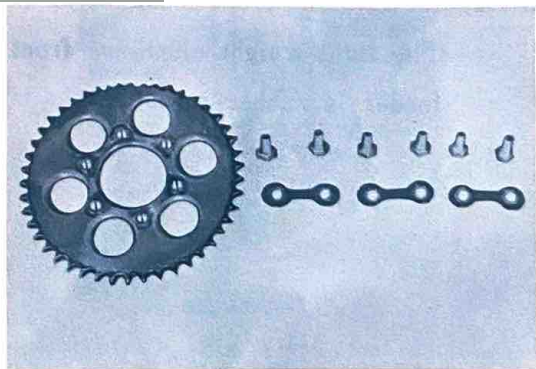

Fig. V-3-5

## V-4 Tires and Tubes

### 1) Normal tire pressure

Though tire pressure is the rider's choice, the standard tire pressure is as follows.

#### a. On-the-road riding

Front .....14 lbs./in<sup>2</sup>. (1.0 kg./cm<sup>2</sup>.)

Rear .....17 lbs./in<sup>2</sup>. (1.2 kg./cm<sup>2</sup>.)

When the tire pressure is reduced below the specified value because of some reason, the tire may slip around the rim.

To prevent this slipping of the tire, bead stoppers should be used.

## V-5 Front Forks

The AT1-C is equipped with competition designed telescopic double dampening front forks. These specially designed front forks provide excellent riding comfort along with handling superiority. The maximum stroke travel is almost 5.8 inches (145 mm.)

The combination of fork stability and long stroke travel provides safety and handling ease for the rider over even the roughest terrain. This front fork design also reduces weight, eases maintenance, and gives functional and attractive appearance. The simplicity and dependability of the front forks is provided by the installation of the fork spring inside of the fork tube.

The 250 DT1 front fork can be used for the AT1-C without modification.

### A. Removal

#### 1) Remove the front fender

The light-weight aluminum front fender is rubber-mounted.

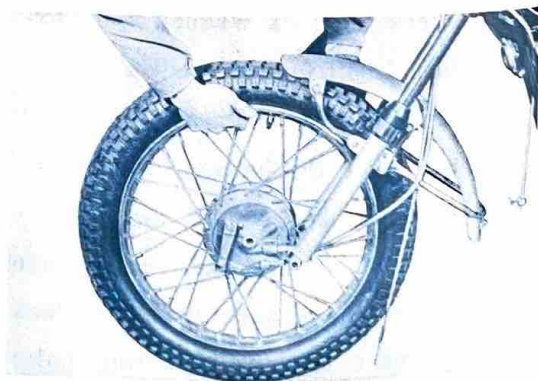

Fig. V-5-1

- 
- 2) Remove the inner tube cap bolt.  
Loosening the arrow marked pinch bolt must be done before the cap bolt is loosened.

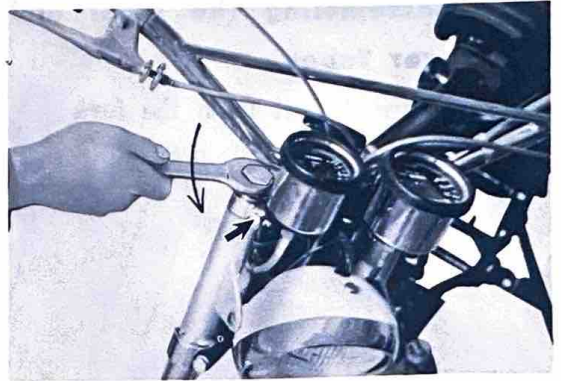

Fig. V-5-2

- 3) Loosen the inner tube pinch bolt on the underbracket.

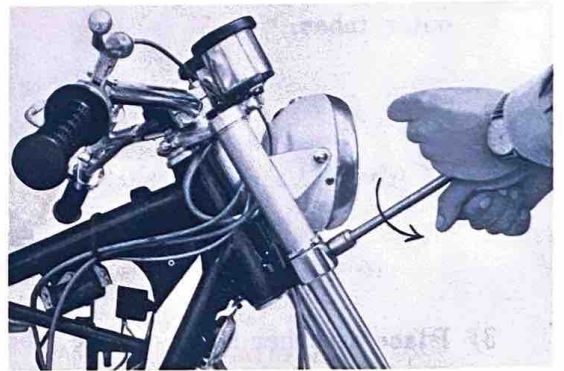

Fig. V-5-3

- 4) Pull the outer tube downward



Fig. V-5-4

## B. Disassembling the Inner and Outer Tubes

1) Drain the oil from the fork



Fig. V-5-5

2) Remove the special bolt (arrow marked) from the bottom of the outer tubes.

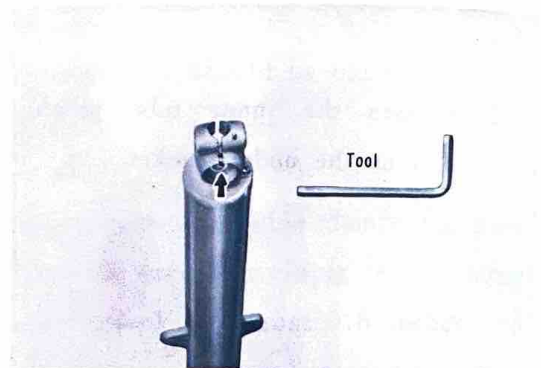

Fig. V-5-6

3) Place a rubber sheet or tire tube around the outer tube nut, and clamp it with a vise.

**Note:** Take care not to deform the outer tube when clamping it with the vise.

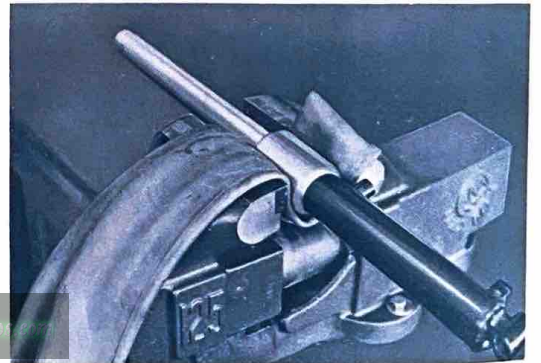

Fig. V-5-7

4) Fit the front wheel shaft in the outer tube, and turn it counter-clockwise. The inner tube can be separated from the outer.

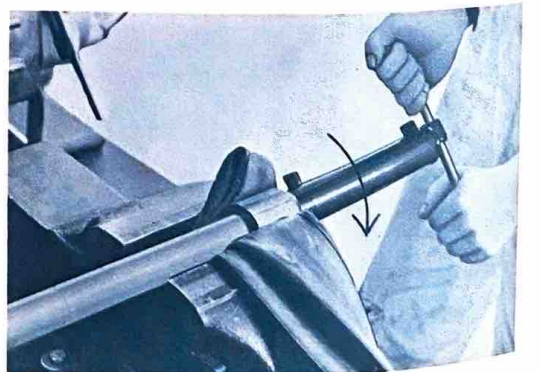

Fig. V-5-8



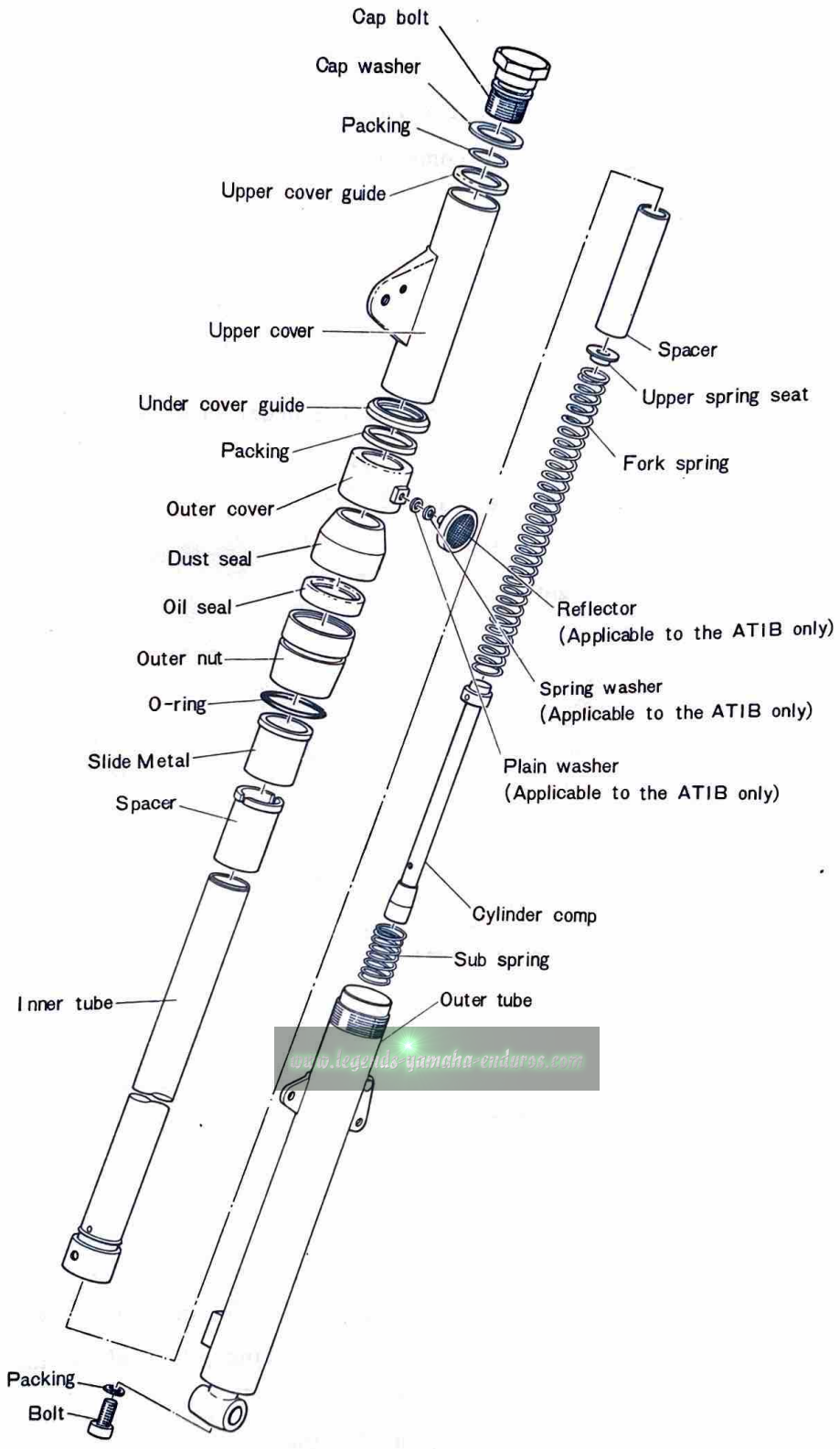

Fig. V-5-9 Front Fork Exploded View

## C. Checking

### 1) Inner tube

Check the inner tube for bends or scratches. If the bend is slight, it can be corrected with a press. It is recommended, however, to replace the tube if possible.

### 2) Oil seal

When disassembling the front fork, replace the oil seal in the outer tube nut.

## D. Assembling

1) When assembling the front fork, reverse the order of disassembly. Check if the inner tube slides in and out smoothly.

### 2) Installing the front fork on the frame

- a. Bring up the front fork to the correct position and tighten the under bracket mounting bolt.



Fig. V-5-10

- b. Pour oil into the inner tube through the upper end opening. Front fork oil: Motor oil 10 W/30 145~160 cc (4.9~5.4 fl. oz.) per fork leg.
- c. Install the cap bolt.

## V-6 Rear Shocks

The rear shocks have a maximum stroke of 90 mm. (3.54 in.) The rear cushion features superb damping and 3-position adjustable springs, that allow the rider to adjust the rear shocks to suit any riding condition.

It is possible to use the DT1 rear cushions for the AT1-C without modifying them.

---

## A. Checking the Condition of the Damping Units.

- 1) Remove the rear shock assembly.

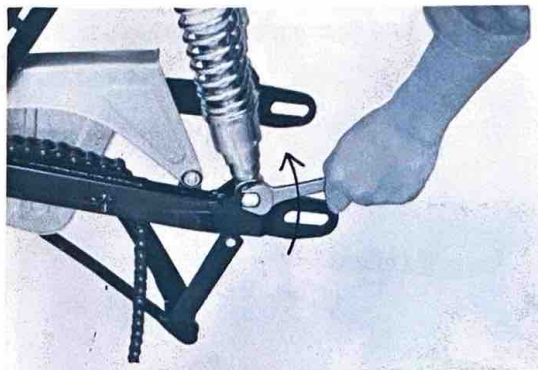

Fig. V-6-1

- 2) Compress the shock by applying weight as shown in Fig. V-6-2, and release it.

If the shock quickly restores halfway and then slowly returns to the original position after it reaches 10 mm. (3/8 in.) before the original position, the rear shocks are in good condition.

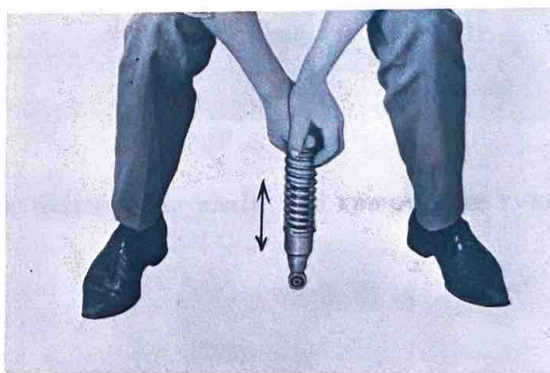

Fig. V-6-2

But if the cushion returns quickly to the original position, check the cushion for oil leakage, and replace the assembly if it leaks.

## V-7 Gas Tank

The front of the tank is held to the frame by a hook on the tank that slips over a pin, and the rear is held by rubber band. Tank capacity is 7.2 litres (1.9 u.s.gal)

### A. Removing

- 1) Set the petcock lever at the "Stop" position and disconnect the fuel line at the petcock.

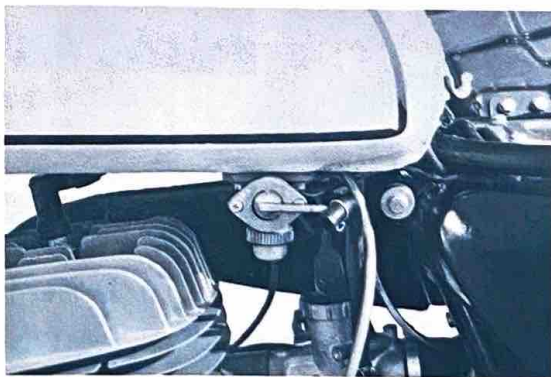

Fig. V-7-1

2) Open the seat.

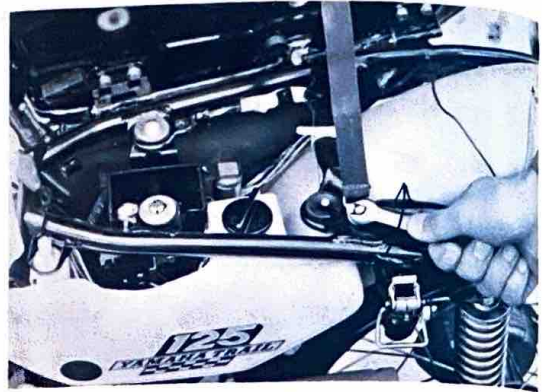

Fig. V-7-2

3) Remove the rubber band.

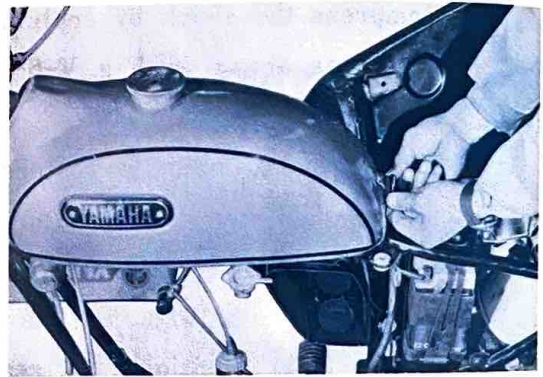

Fig. V-7-3

4) Remove the gas tank.



Fig. V-7-4

---

## V-8 Rear Swing Arm

The rear swing arm is made of steel tube that improves the strength and torsional rigidity. The pivot employs permanently lubricated bearings.

### A. Removing

- 1) Remove the chain case mounting bolts.

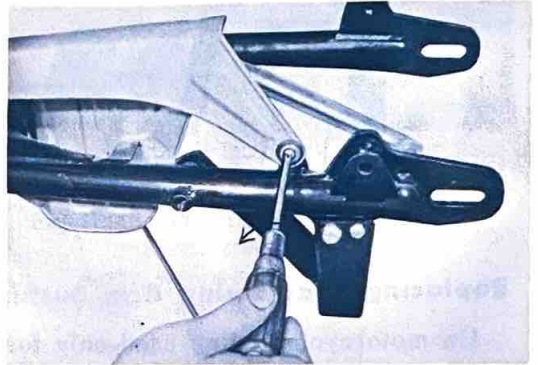

Fig. V-8-1

- 2) Remove the rear swing arm shaft nut, pull out the shaft, and remove the rear swing arm.

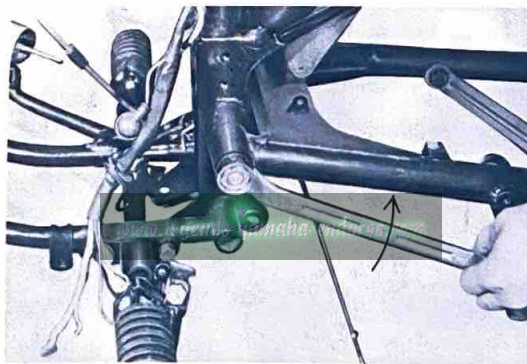

Fig. V-8-2

### B. Checking

- 1) Check the play of the rear swing arm by shaking it as shown in Fig. V-8-3, with the rear swing arm installed. If the play is excessive, replace the rear swing arm bushing or the rear swing arm shaft.
- 2) Insert the bushing as indicated in Fig. V-8-4, and check it for play. If the play is excessive, replace the bushing.

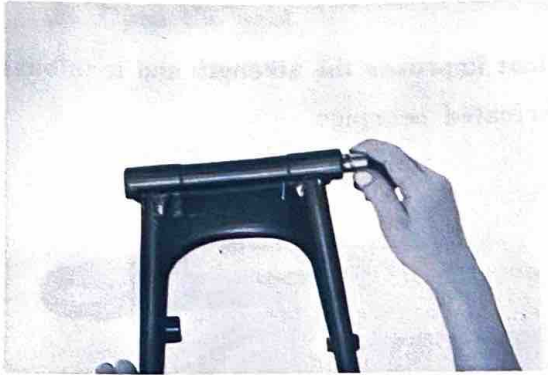

Fig. V-8-3

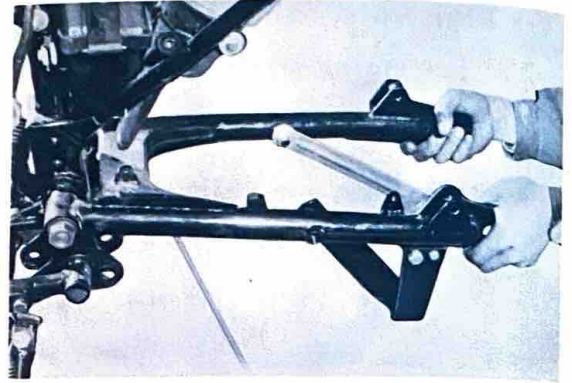

Fig. V-8-4

3) Grease the rear arm shaft periodically.

### **Replacing Rear Swing Arm Bushings**

On motorcycles being used only for on-the-street riding, rear swing arm bushings should be replaced every 10,000 km. (6,000 miles). The same may not apply to those used for racing or rough riding. Replacement should be made according to machine condition such as excessive play of the rear swing arm, or hard steering (wander, shimmy or rear wheel hop,) or upon request of the customer.

## V-9 Steering Head

### A. Sectional View of the Steering Head

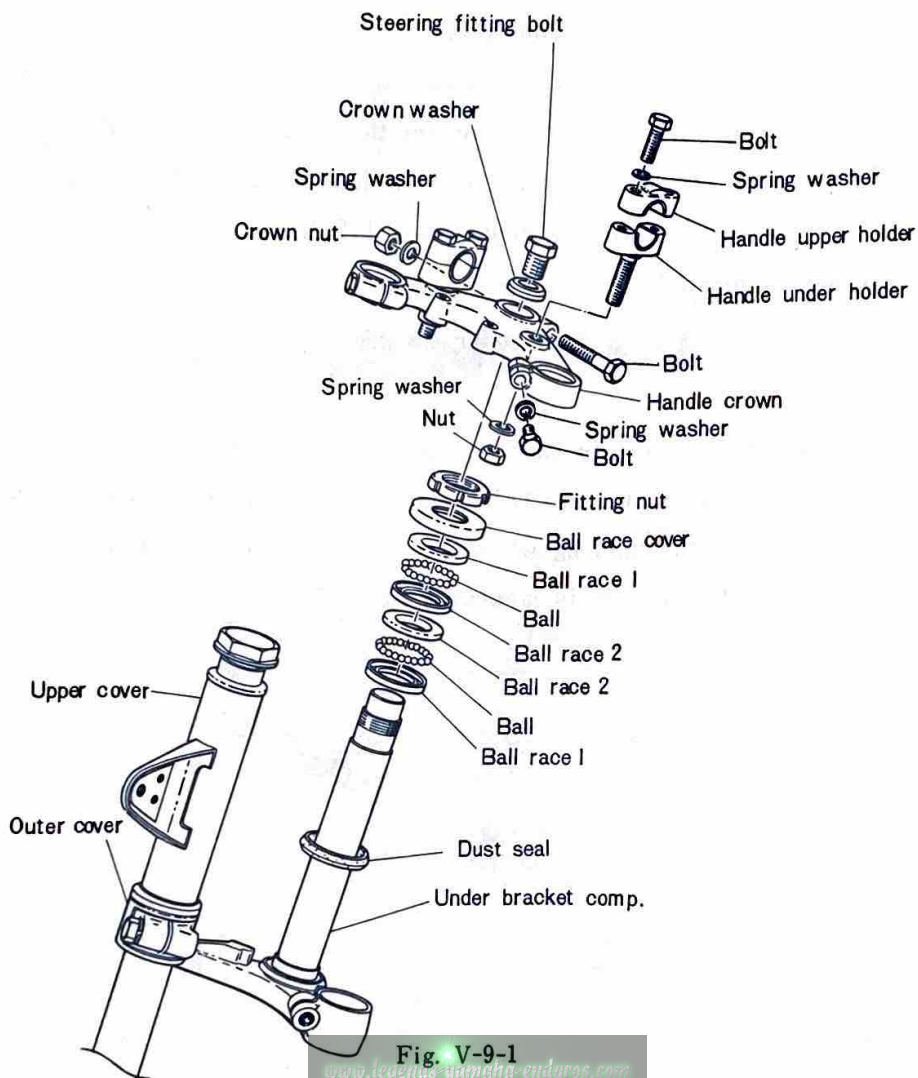

### B. Checking

#### 1) Ball Races and Steel Balls

Check the ball races and steel balls for pitting or wear. Check them very carefully if the machine has been in long use. If they are worn or cracked, replace all of them, because defective ball races or steel balls adversely affect the maneuverability of the machine. Replace any ball race having scratches or streaks resulting from wear. Clean and grease the balls and races periodically.

---

**Note:** Do not use a combination of new balls and used races or vice versa. If any of these are found defective, replace the whole ball and race assembly.

### V-10 Oil Tank, Battery Box and Tool Box

The oil tank is located on the left side under the seat. It is designed to be as narrow as possible so that it will not contact the rider's lower limbs when he stands upright on the footrests. To fill the autolube oil tank, lift the seat and the tank cap will be exposed. Oil tank capacity.....1.2 litres. (1.3 u.s qts)

The battery box is located right under the seat.

And the air cleaner case is located under the fuel tank.

### V-11 Frame

The double cradle-type frame is made of high tension steel tubes that provide strength, rigidity and light weight. Other dimensional features include high ground clearance, narrow width, and long wheelbase. The engine is bolted to the frame at three positions. The caster is measured at 60.50°.

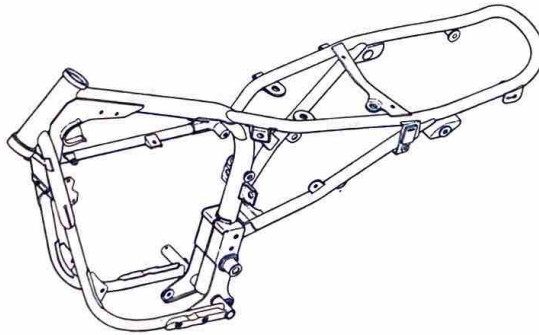

Fig. V-11-1

### V-12 Handlebars

The upswept type longer handlebars are ideal for motocross events and are provided with deep-cut pattern grips to prevent hand slippage. The lever holder is provided with adjusting screws for clutch cable and brake cable free play.

The meter bracket is mounted on the ends of the handle crown, to carry the speedometer on its left side and the tachometer on its right side.

### V-13 Miscellaneous

The footrest is made of a single steel tube extending under the lower part of the frame, and bolted to the frame. The engine guard is bolted to the frame to protect the entire crankcase.....covering from the exhaust system to the drain plug.

---



---

## Chapter VI Electrical System for AT1-MX

### VI-1 Description

The AT1-MX employs a flywheel magneto for its ignition system, same as in the DT1. As the AT1-MX is designed exclusively for off-the road riding, it is equipped with the flywheel magneto and ignition coil only; lights, signals, battery, rectifier and switches are not mounted.

## AT1-MX WIRING DIAGRAM

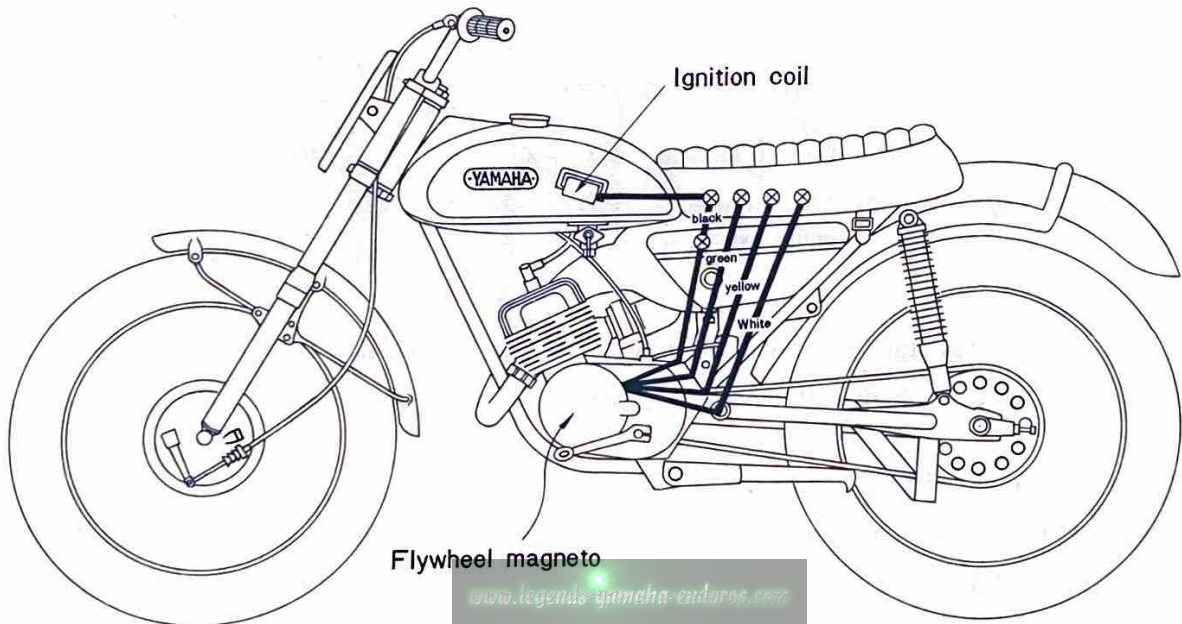

## VI-2 Ignition System—Function and Service

### 1. Function

The ignition system consists of the components as shown in Fig. VI-4-1. As the flywheel rotates, the contact breaker points begin to open and close, alternately. This make-and-break operation develops an electromotive force in the ignition power source coil, and produces a voltage in the ignition coil primary windings. The ignition coil is a kind of transformer, with a 1:50 turn ratio of the primary to the secondary winding. The voltage (150-300 V) which is produced in the primary coil, is stepped up to 12,000-14,000 V by mutual-induction, and the electric spark jumps across the spark plug electrodes.

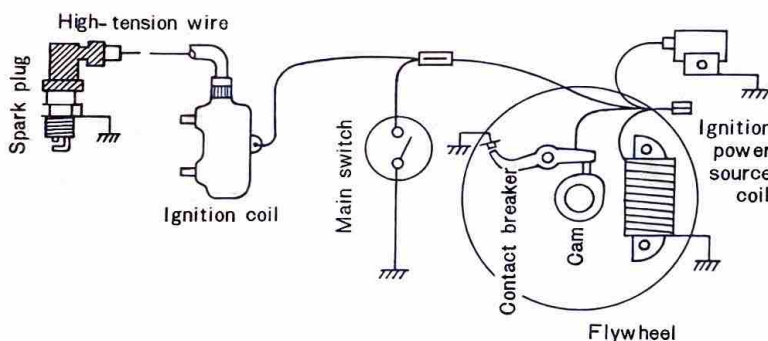

Fig. VI-4-1

### VI-3 Ignition Timing

Remove the spark plug and screw the dial indicator holder into the plug hole. Next, insert the dial indicator into the holder. Bring the piston up to T.D.C. and set the zero on the dial face to line up exactly with the dial indicator needle. The crankshaft should then be turned backwards, so that the piston travels down past 2.0 mm B.T.D.C. and slowly brought back up to precisely 2.0 mm B.T.D.C. (This removes any slack in the gears). Adjust the points so that they are just beginning to open with the piston in this position. A low resistance point checker (100 Ohms or less) should be used to determine the opening and closing of the ignition points.

Ignition Timing, 2.0 mm. B. T. D. C.

Maximum ignition point gap 0.3 to 0.4 mm. (0.012"-0.015")

## VI-4 Ignition Coil

Primary coil resistance value ..... $4.9\ \Omega \pm 10\%$  ( $20^{\circ}\text{C}$  or  $68^{\circ}\text{F}$ )

Secondary coil resistance value ..... $11\ \text{K}\Omega \pm 10\%$  ( $20^{\circ}\text{C}$  or  $68^{\circ}\text{F}$ )

(For measuring methods, refer to Fig. VI-6-1)

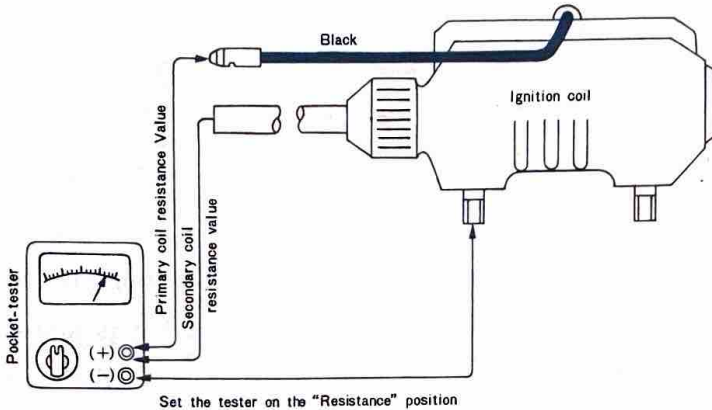

Fig. VI-6-1

**Note:** When measuring the secondary coil resistance value, disconnect the plug cap. Otherwise, the resistance of the  $5\text{K}\Omega$  noise suppressor incorporated in the plug will be added to the tester reading.

### Spark Test:

Remove spark plug from cylinder head and reconnect the high voltage lead. Then hold the spark plug approximately 7 mm away from the head and see if it sparks as you crank the kickstarter.

If it sparks at 7 mm. or so, and has blue white color, the ignition coil should be considered to be in good condition.

[www.legends-yamaha-enduros.com](http://www.legends-yamaha-enduros.com)

## VI-5 Condenser

The condenser instantly stores a static electric charge as the contact breaker points separate, and the energy stored in the condenser discharges instantly when the points are closed. If it were not for the condenser, an electric arc would jump across the separating contact points, causing them to burn.

Burned contact points greatly affect the flow of current in the primary winding of the ignition coil.

If the contact points show excessive wear, or the spark is weak (the ignition coil is in good condition), check the condenser.

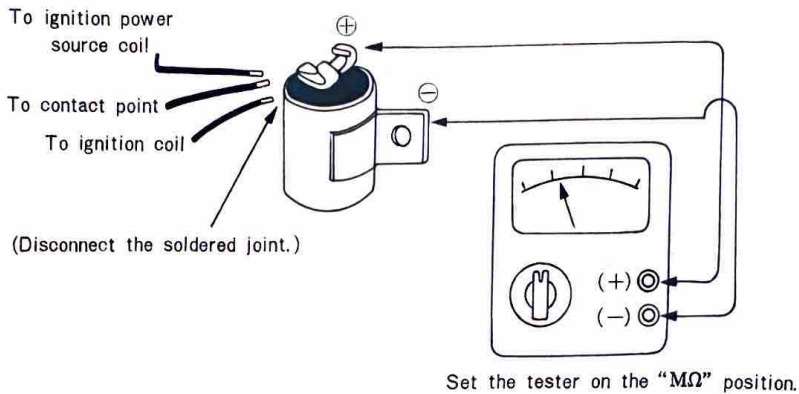

Fig. VI-7-1

Insulation resistance tests should be conducted by connecting the tester as shown in Fig. VI-7-1. If the pointer swings fully and the reading is more than  $3M\Omega$ , the insulation is in good condition. If the insulation is faulty, the pointer will stay pointing at the uppermost reading, indicating very little resistance.

**Note:** After this measurement, the condenser should be discharged by connecting the positive and negative sides with a thick wire.

Capacity tests can be performed by simply setting the tester to the condenser capacity. The tester should be connected with the condenser in the same way as in the case of the insulation resistance test. Before this measurement, be sure to set the tester correctly.

If the reading is within  $0.22 \mu F \pm 10\%$ , the condenser capacity is correct.

## VI-6 Spark Plug

The life of a plug and its discoloring vary, according to the habits of the rider. At each periodic inspection, replace burned or fouled plugs with suitable ones determined by the color and condition of the bad plugs. One machine may be ridden only in urban areas at low speeds, whereas another may be ridden for hours at high speeds, so confirm what the present plugs indicate by asking the rider how long and how fast he rides, and recommend a hot, standard, or cold plug accordingly. It is actually economical to install new plugs every 3,000 km (2,000 miles) since it will tend to keep the engine in good condition and prevent excessive fuel consumption.

---

## 1. How to "read" spark plug (condition)

- a. Best...When the porcelain around the center electrode is a light tan color.
- b. If the electrodes and porcelain are black and some what oily, replace the plug with a hotter-type for low speed riding.
- c. If the porcelain is burned white and/or the electrodes are partially burned away, replace the plug with a colder-type for high speed riding.

## 2. Inspection

Instruct the rider to:

Inspect and clean the spark plug at least once a month or every 1,000 km. (500 miles) Clean the electrodes of carbon and adjust the electrode gap to 0.5-0.6 mm. (0.023 in.) Be sure to use B-9E plug as replacements to avoid any error in reach.

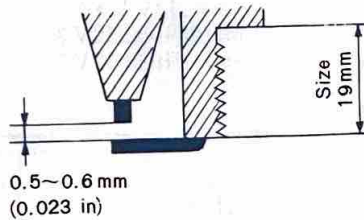

Fig. VI-11-1

## Chapter VII Electrical System for AT1-C

### VII-1 Description

The YAMAHA 125 AT1-C is equipped with a large-sized starter dynamo, which serves as a high-output D-C generator as well as a starter. This enables all electrical terminals to keep voltages almost constant at all times regardless of engine speeds. All electrical parts are of 12-V capacity.

### VII-2 Table of Component Parts

Parts	Manufacturer	Model & Type	Remarks
Starter dynamo Spark plug	Hitachi Ltd. NGK	GS114-01 B-8E	
Head light	Koito Mfg.	12V 25WD High beam indicator light 12V 1.5W	Metal-back sealed beam
Speedometer Tachometer Left handlebar switch Right handlebar switch	Nippon Seiki Nippon Seiki Asahi Denso Asahi Denso	Meter light 12V 3W Meter light 12V 3W	Is interchangeable with DT1
Main switch Ignition coil Horn	Asahi Denso Hitachi Ltd. Nikko Kinzoku	CM-11-50 MF-12	Is interchangeable with A7
Battery Regulator Starting switch Fuse	Furukawa Battery Hitachi Ltd. Hitachi Ltd. Osachi Mfg.	12N7-3B1-1, 12V7AH T107-17 A104-35 20A×2	
Front stop switch Rear stop switch	Asahi Denso Asahi Denso		Is interchangeable with DT1
Tail/Stop light	Stanley Elec.	12V 7W/23W	

[www.legends-yamaha-enduros.com](http://www.legends-yamaha-enduros.com)

### VII-3 Main Components

#### 1. Ignition System

The main parts consist of:

Contact breaker (connected to the dynamo)

Condenser (connected to the dynamo)

Ignition coil, spark plug, high tension lead, and battery.

#### 2. Charging and Starting Systems

Charging system: The purpose of the charging system is to charge the battery equipment (lights, horn, etc) while the machine is running.

Starting system: Electric starter system is used to crank the engine.

The main parts of these two systems are:

Dynamo (yoke, armature, brushes), regulator (with cutout relay), starter button (with starting switch), fuse and battery (power source).

### 3. Lighting and Signal Systems

The lighting and signal systems consist of signal lights, switch and meter lights (signal system) and illumination lights for night travel.

Signal system: Horn, stop light, and switches.

Lighting system: Headlight, taillight, and meter lights.

#### VII-4 Connection Diagram

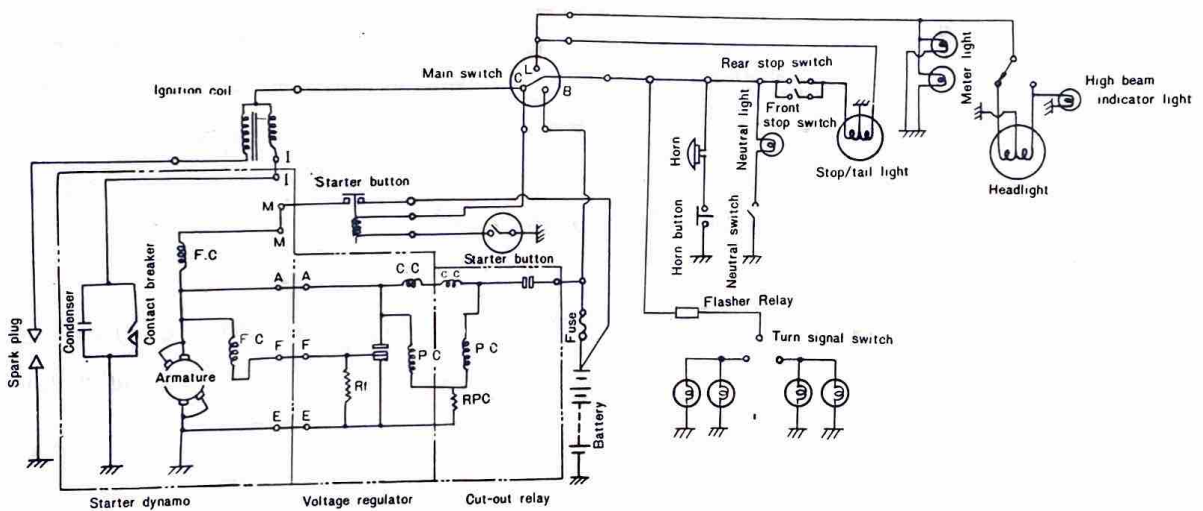

www.legenFig.VII-4-1uros.com

#### VII-5 Starter Dynamo

The dynamo ass'y is made up of the yoke ass'y (field coil, contact breaker, condenser, etc), the armature ass'y (armature coil, commutator) and the cam ass'y, and supplies power to the ignition and charging systems.

Ignition system:

The ignition system consists of the contact breaker, condenser, and cam. The system interrupts the current flowing from the battery to the primary coil, thereby inducing a high voltage charge in the secondary coil.

### a. Contact Breaker Ass'y

Incorrect ignition timing results in irregular engine speeds, thereby causing an engine knock or vibrations. It also causes loss of engine power or engine overheating, thus shortening engine life. Check the contact breaker periodically.

### b. Condenser

The condenser stores electricity from the breaker points when the points open, and discharges the static when the points close. It prevents sparking between the points, minimizing burning by absorbing an abrupt increase in electricity when the breaker points open, and it amplifies the effect of the primary ignition coil.

### Charging System:

The charging system of the starter dynamo consists of the yoke ass'y (shunt field coil and brushes) and the armature ass'y (commutator). The armature coil cuts through the magnetic lines of force of the field coil as the engine runs so that a flow of alternating current is induced. The alternating current is converted into a direct current through the commutator brushes. The direct current voltage is kept constant by the voltage regulator, and supplied to each load of the ignition, lighting and signal systems as well as to the battery.

### Starting System:

In the starting system of the starter dynamo, the series coil and the armature, working as a D.C. motor, generate a great amount of torque, by which the engine is cranked.

## 1. Inspection and Repairs

### A. Checking the Dynamo

First disconnect the wires from the terminals A (white) and F (green), then ground the terminal F to E... (black), with a jumper wire. Connect the positive lead of the tester to terminal A (white), and ground the negative tester lead to the engine. Start the engine and keep it running at 1,800 rpm. If the electricity generated reads more than 10V on the tester, the gene-

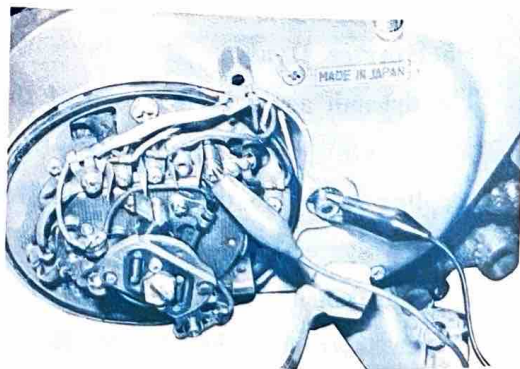

Fig. VII-5-1



---

rator is in good working condition.

Caution: Do not run the engine at more than 1,800 rpm in this test. If you run the engine at more than 1,800 rpm, a high voltage current generated will ruin the coil, lead wire, etc. (Fig. VII-5-1)

## B. Checking the Yoke Ass'y

Clean the yoke with a rag to remove dust, oil, and carbon from brush wear, etc.

### 1) Field Coil Brush Insulation Test

The positive brush of the field coil is insulated from the yoke and by using the tester, you can check its insulation as shown in Fig. VII-5-2. If the insulation is bad, the circuit between the field coil or the brush holder, and the yoke is shorted. (Note: The negative brush is not insulated.)

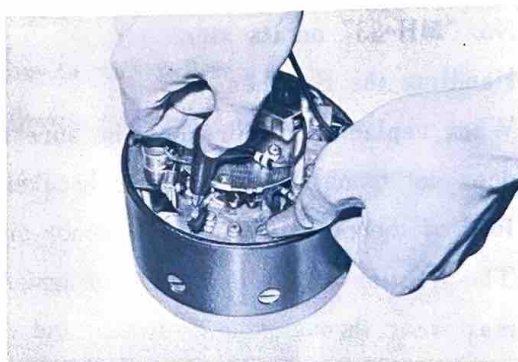

Fig. VII-5-2

### 2) Conductivity Test of Field Coil

Check the continuity between the terminals M, A, and F. If continuity is bad, the field coil is broken. Check the visible coil connections. If the coil connections are good, then the coil is broken inside and it should be replaced because repairs are very difficult.

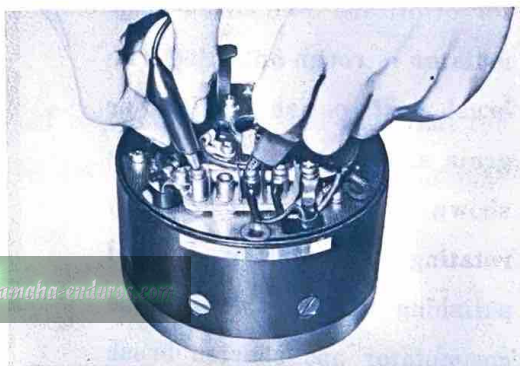

Fig. VII-5-3

### 3) Checking the Brushes

The brushes are one of the most important parts in the dynamo. Take out the brushes and check the condition of their contact surfaces. Each brush must contact the commutator with more than  $\frac{3}{4}$  of its surface area.

If both brush and commutator surfaces are rough, check both the crankshaft and armature for alignment. Smooth down any burrs on the edge of the

---

armature's tapered bore, and clean it thoroughly.

If either brush is worn past the minimum length mark, replace them both with new ones. (Fig. VII-5-4)

#### 4) Materials of the Brush

Use the brush having the model No. "MH-33" on its side.

#### 5) Handling the Brushes

When replacing the brushes, be sure the braided lead of the positive brush does not touch the edge of the breaker plate or brush holder, and that the lead of the negative brush does not touch the positive brush spring.

The friction of the braided lead against other parts as a result of vibrations may wear through the insulation and cause a short circuit.



Fig. VII-5-4

### C. Checking the Armature Ass'y

- 1) Thoroughly clean the commutator of oil and dirt. If the commutator is rough or dulled with brush dust, polish it with fine grain sandpaper (#400-600) as shown in Fig. VII-5-5, by rotating the armature. Partial polishing will only deform the commutator and shorten brush life.

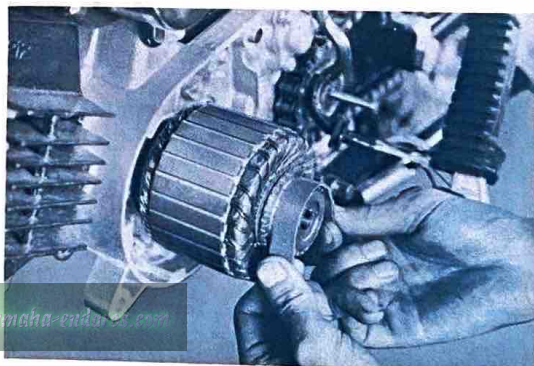

Fig. VII-5-5

If the commutator is burned, out of round, or too rough to be sandpapered, turn it on a lathe no more than 2 mm under the standard 40 mm diameter.

#### 2) Checking the Commutator Mica Under-Cut

If the commutator is worn and if it has high mica, the mica should be undercut with a saw blade:

Sand off all burrs with sandpaper. Be sure the mica is cut away clean between segments, leaving no thin edge next to segments. (Fig. VII-5-6)

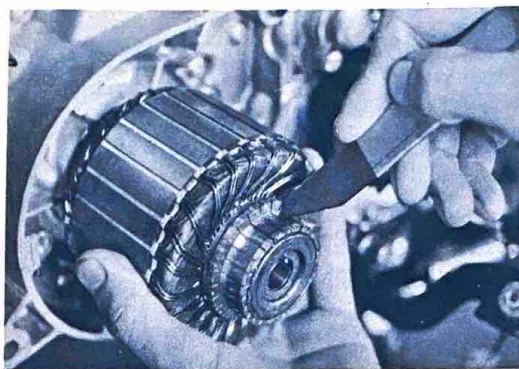
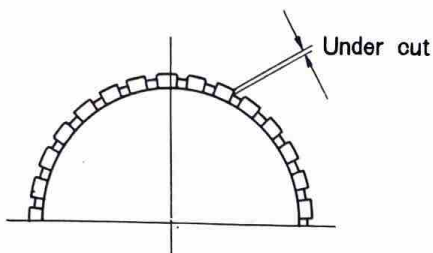

Fig. VII-5-6

Mica undercut inspection limits: 0.5-0.8 mm

Mica undercut correction limits: 0.2 mm

### 3) Checking the Armature for Insulation

If there is electrical leakage between the commutator and shaft, replace the whole armature. (Fig. VII-5-7)

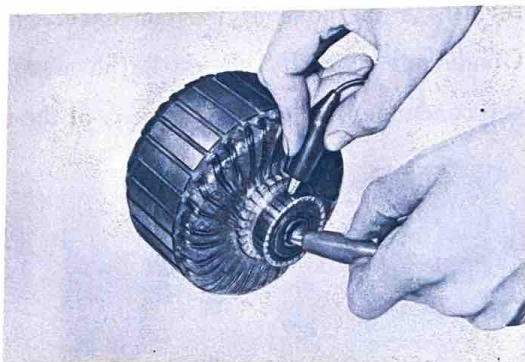

Fig. VII-5-7

- 4) If the field coil is perfectly insulated and conductivity is also good, but the dynamo will not generate electricity, the core of the armature coil might be short-circuited.

Check the armature with a growler at a special service shop.

## D. Checking the Condenser

### 1) Insulation Tests

Hook up an electro tester (service tester) for the insulation resistance test, and attach the tester terminals to those of the condenser. If the tester needle swings once and then returns to its original position, the condenser is in good condition. Condenser leakage will hold the needle at a maximum reading. If the reading is more than  $3M\Omega$ , the condenser is good. Ground the condenser terminals to discharge the stored electricity. (Figs. VII-5-8 and 9)

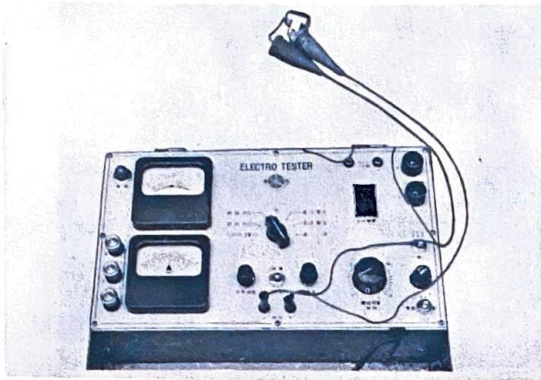

Fig. VII-5-8

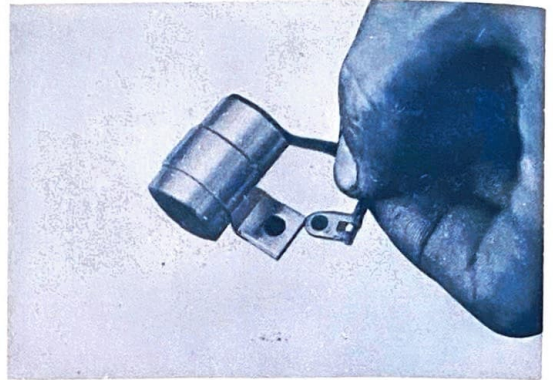

Fig. VII-5-9

## 2) Capacity Tests

Set the service tester for the condenser capacity position, and connect its terminals to those of the condenser.

Condenser capacity should be no more than  $0.22\mu\text{F}\pm 10\%$ . Before testing the condenser, adjust the capacity of the service tester. (Figs. VII-5-10 and 11)

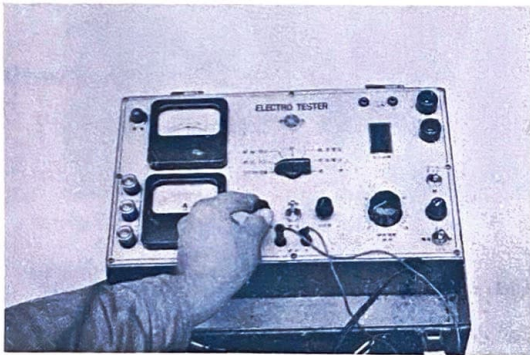

Fig. VII-5-10

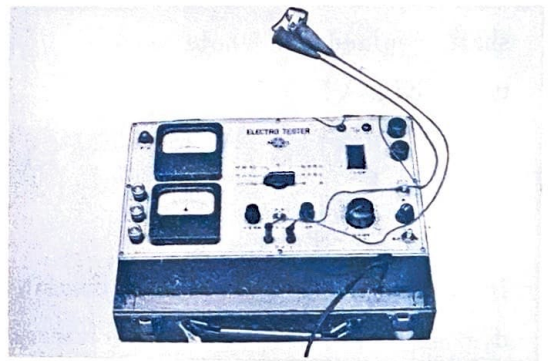

Fig. VII-5-11

**Note:** When you make this test with the condenser mounted on the dynamo, disconnect the wires from the terminals, and insert a piece of cardboard between the breaker points.

In this test, the insulation resistance of the contact breaker can be tested at the same time. If the insulation resistance is too low, disconnect the lead wires from the condenser, and test it again.

## E. Contact Breaker

- 1) Periodically inspect the breaker points and check the point gap. If the gap is incorrect, adjust it.
- 2) Periodically inspect the breaker points for any pitting.

Excessive pitting should be smoothed out with sandpaper (#400-600), and wiped off with soft cloth. (Fig. VII-5-12)

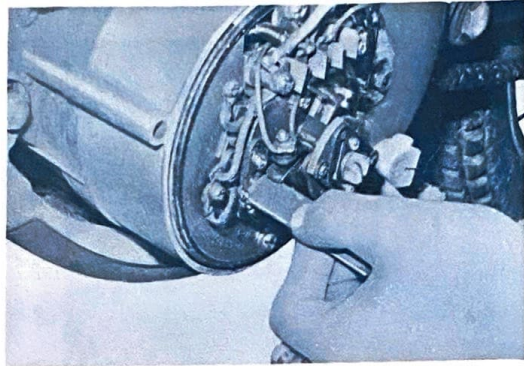

Fig. VII-5-12

- 3) After every 5,000 km (3,000 miles) inspect the breaker cam lubricator and grease it a little.
- 4) Oil or dust on the points impairs spark performance.  
The oil on the points will considerably shorten point service life. Wipe it off from time to time.

#### F. Adjusting Ignition Timing

- 1) Tools and instruments for adjusting:

Dial gauge (accuracy-1/100 mm)

Dial gauge adapter

Continuity testing lamp, YAMAHA electro tester or YAMAHA point checker

Point wrench

Slot-head screw driver

12mm wrench

- 2) Adjust ignition timing

[www.legends-yamaha-enduros.com](http://www.legends-yamaha-enduros.com)

- a) Set the point gap at 0.30-0.40 mm (0.012~0.014") (Fig. VII-5-13)
- b) Remove the spark plug and screw the dial indicator holder into the plug hole. Next, insert the dial indicator into the holder. Bring the piston up to T.D.C. and set the zero on the dial face to line up exactly with the dial indicator needle. (Fig. VII-5-14)

Remove the lead wire from terminal I. Connect the positive (+) tester lead to the terminal I, and ground the tester's negative lead to the frame.

(Fig. VII-5-15)

- f) Turn the crankshaft back well past 1.8 mm, to eliminate play in the gears,

---

and then bring the piston up to exactly 1.8 mm B.T.D.C. (Fig. VII-5-16).

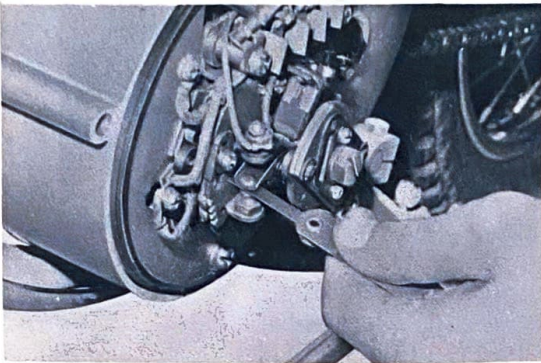

Fig. VII-5-13

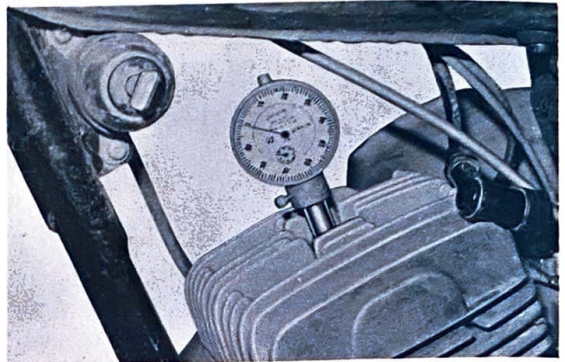

Fig. VII-5-14

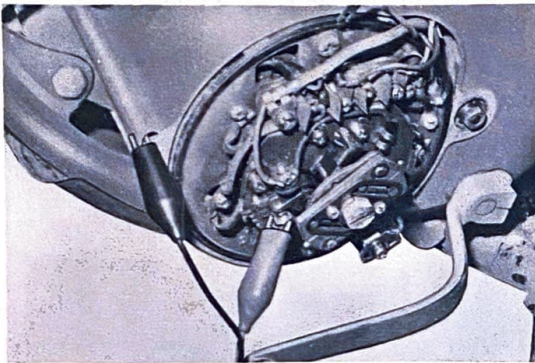

Fig. VII-5-15

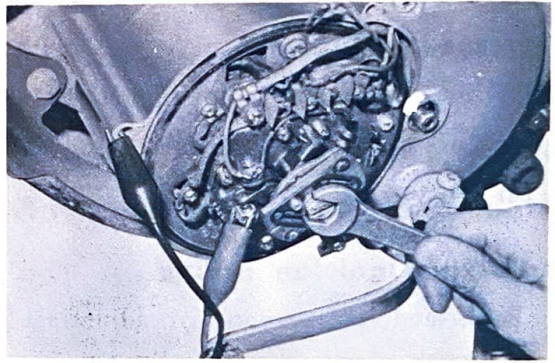

Fig. VII-5-16

- d) Wedge the governor, fully open. Then loosen the breaker plate holding screws, and turn the breaker plate. When the points just start to open (the testing lamp lights up), tighten the holding screws. (Do not fully loosen the breaker plate holding screw, because the breaker plate tends to shift its position). Turning the breaker plate in the engine rotation direction causes ignition timing to delay, and turning it in the opposite direction advances ignition timing. (Figs. VII-5-17 and 18)

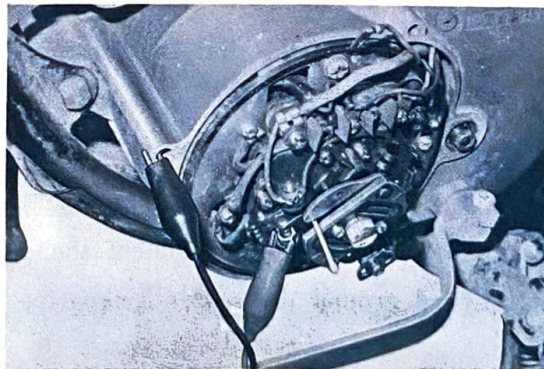

Fig. VII-5-17

## 8) Dynamo Adjustment Standards

Part	Item	Maintenance	Inspection
Field	Resistance Shunt Series	4.8Ω @20°C (68°F) 0.0268Ω @20°C (68°F)	When voltage is irregular
Brushes	Material  Number Width×thickness×length Minimum length Spring capacity	MH-33  4 9×4.5×20.5 mm 9 mm 400±10% -560±10% (initial use)	First 6,000 km (4,000 mi.) Every 4,000 km thereafter (2,500 mi.)
Commutator	Diameter Minimum diameter Mica undercut Minimum mica undercut Difference between max. and min. diameter	38.5 ϕ mm 36.5 ϕ mm 0.5-0.8 mm 0.2 mm 0.03 mm	
Breaker	Point gap Point pressure Ignition timing Automatic spark advance	0.30-0.40 mm 500~700 g BTDC 1.8 mm Starting 1,350±150 rpm Final 1,600±100 rpm Advance 12±2°	Every 3,000 km (2,000 mi.) (High rpm irregular) (Ignition irregular)
Others	Dynamo dia. (outer) Dynamo dia. (inner) No. of poles Air gap Armature taper Cut-in rpm	134 ϕ mm 130 ϕ mm 8 0.35 mm 20ϕ×1/5 2,000 rpm	
Capacity	Rated output rpm	14-V, 4.5A/1,950 rpm	

---

## VII-6 Regulator (Voltage Regulator)

The dynamo alone can not provide stable electric current because fluctuating engine rpm affects the voltage. The regulator (also called a voltage relay) stabilizes the voltage generated by breaking the field coil circuit when the voltage exceeds a pre-set level.

A cutout relay (also called a charging relay) is built into the regulator. It allows stable electric current from the dynamo to charge the battery. However, when the engine stops, or when its speed is so low that the dynamo output is lower than that of the battery voltage, it breaks the circuit to the battery so the battery will not drain. The starting switch is provided to direct a flow of current to the starter dynamo when the engine is started.

### 1. Inspection and Adjustment

If the regulator can no longer control the voltage, the battery will be drained or over-charged, and all electrical parts may be burned out. So use a good tester when inspecting or adjusting the regulator. (It is advised that you learn how to adjust the regulator at training courses because it is very difficult.)

#### A. No-Load Voltage

##### 1) Inspection

- Disconnect the lead wire (red) of the regulator and connect the positive tester lead to the lead wire (red). Then ground the negative tester lead.
- Start the engine and keep it running at 2,500 rpm. Your regulator is correct if the tester reads 15.8-16.5 V. (Fig. VII-6-1)

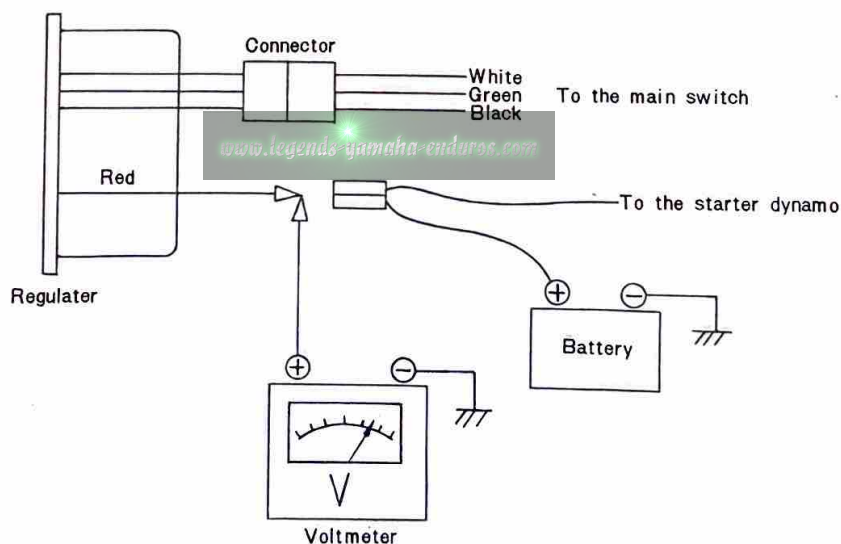

Fig. VII-6-1



## 2) Adjustment

If the measured voltage is more or less than specified, adjust it by tightening or loosening the adjusting screw on the voltage relay side.

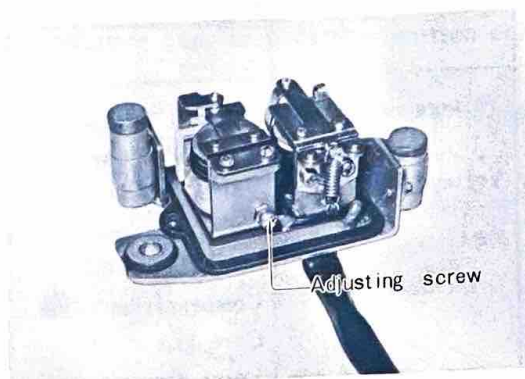

Fig. VII-6-2

## B. Cut-in voltage of the Cutout Relay

### 1) Inspection

- Disconnect the lead from the dynamo A terminal, connect the tester positive lead to the A terminal, then ground the negative lead to the engine.

(Fig. VII-6-3)

- Start the engine, and increase engine speeds slowly. The cutout relay is correctly set if its breaker points close at 12.5-13.5 V. (approx. 1,800 rpm)

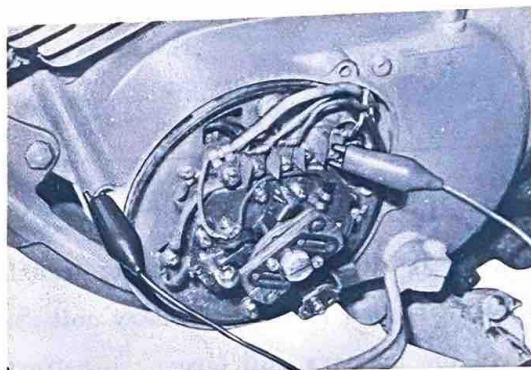

Fig. VII-6-3

### 2) Adjustment

If the breaker points will not close at the specified voltage, adjust the cutout relay by changing its spring tension.

(Fig. VII-6-4)

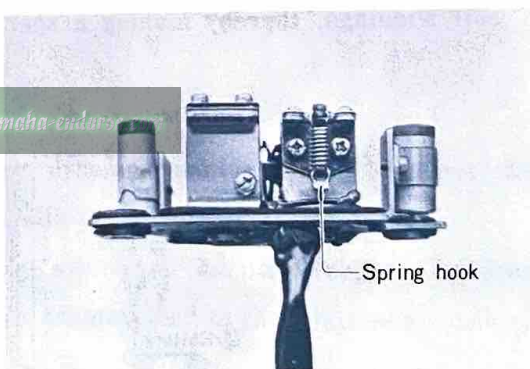

Fig. VII-6-4

In actual practice, there will rarely be need to adjust the cutout relay. If the point surfaces of the voltage and cutout relays are worn or pitted, polish them with fine sandpaper (#400-600) before making any adjustment.

### 3) Regulator Maintenance Standards

	Item	Maintenance standards	Inspection
Voltage regulator	No load voltage adjustment value	15.8-16.5V/2,500 rpm	When voltage is irregular
Voltage relay	Voltage coil resistance value	11.8 $\Omega$ /20°C (68°F)	
	Compensation value	10 $\Omega$ /20°C (68°F)	
	Core gap	0.4-0.7 mm	
	Point gap	0.4-0.5 mm	
Cutout relay	Cut-in voltage	13±0.5V	
	Reversing current	5 A or less	
	Voltage coil resistance value	11.2 $\Omega$ /20°C (68°F)	
	Core gap	0.8-1.0 mm	
	Point gap	0.6~0.8 mm	

### VII-7 Ignition Coil

The ignition coil is a kind of transformer, with approximately 50 times the number of windings in the secondary coil as in the primary. If the electric current supplied to the primary coil (from the battery) is interrupted by a contact breaker, the primary coil will create a 150 - 300 V current by selfinduction. This current is boosted to 12,000-14,000 V by mutual induction in the larger number of secondary coil windings, thereby making a spark jump the plug electrodes,

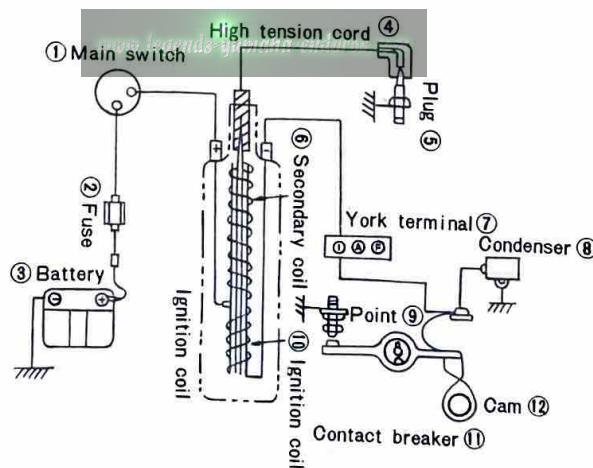

Fig. VII-7-1

## 1. Inspection

If no spark, or a rather weak spark jumps the plug gap, inspect the ignition coil as well as the contact breaker.

- a. When you test the coil alone, use a 12-V battery as power source.

A spark of 7 mm or more means the coil is in good condition.

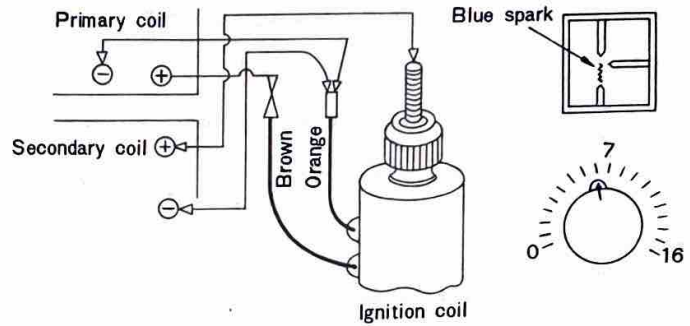
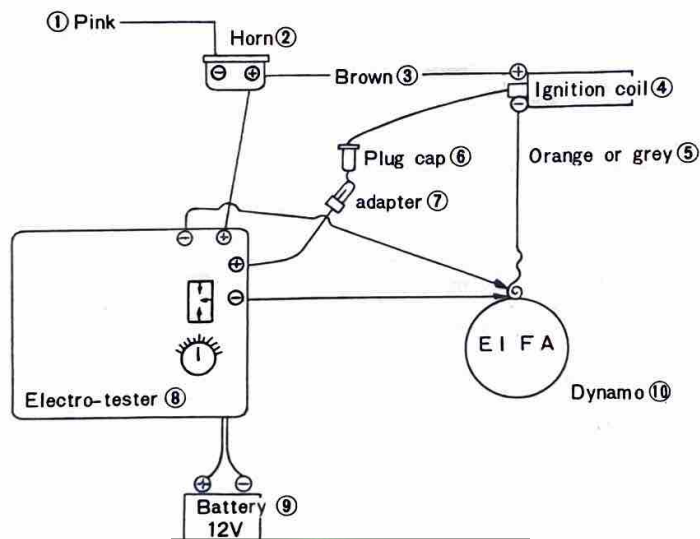

Fig. VII-7-2

- b. Test with Coil Installed (practical test)



www.Fig.VII-7-3a-enduros.com

- Disconnect the lead attached to the ignition dynamo terminal I and connect the negative primary and negative secondary leads of the tester to it.
- Detach the high tension lead from the plug, attach an adapter (copper or iron wire) to the plug lead cap, and connect this adapter lead to the positive secondary lead of the tester.
- Connect the positive primary lead of the tester to the brown lead terminal of the horn.
- Use a 12-V battery as power source for the tester.
- If the tester shows a spark of 7 mm or more, the coil is in good condition.

## Chapter VIII Conversion of the Yamaha AT1-C for racing\* (AT1-MX has these parts)

The Yamaha 125 AT1-C is easily converted into a high-performance motocrosser by installing GYT kit parts.

\*It is suggested that when you desire to make this conversion, you enlist the services of your local Yamaha dealer.

### VIII-1 Engine, Transmission, Carburetor, Flywheel magneto, Tune-up

The engine can be tuned up by simply replacing standard parts with tuned parts.

Parts No.	Parts Name	Description	Q'ty	Remarks
248-11311-70	CYLINDER		1	
248-1111-70	HEAD, cylinder		1	
248-11631-70	PISTON		1	
248-11611-70	RING, piston top		1	
248-11400-00	CRANK ASS'Y		1	
248-11412-00	CRANK (L.H)		1	
214-11557-01	WASHER		1	
92901-12100	WASHER, spring		1	
214-11555-01	NUT, crank shaft		1	
248-15415-00	COVER, generator		1	
248-18111-00	PEDAL, change		1	
214-17819-00	CAP, housing		1	
248-14610-70	EXHAUST PIPE ASS'Y		1	
265-17411-00	AXLE, main	12T	1	
265-17141-00	GEAR, 4th pinion	22T	1	
265-17151-00	GEAR, 5th pinion	23T	1	
265-17121-00	GEAR, 2nd pinion	16T	1	
265-17251-00	GEAR, 5th wheel	22T	1	
265-17241-00	GEAR, 4th wheel	24T	1	
265-17211-00	GEAR, 1st wheel	34T	1	
174-17461-30	SPROCKET, drive	13T	1	
174-17461-40	SPROCKET, drive	14T	1	
174-17461-50	SPROCKET, drive	15T	1	(S.T.D)
174-17461-60	SPROCKET, drive	16T	1	

Parts No.	Parts Name	Description	Q'ty	Remarks
248-14101-70	CARBURETOR ASS'Y	ISO	1	
193-14142-30	.JET, pilot	#30 ISO	1	
168-14190-25	.VALVE SEAT ASS'Y	#2.5	1	
214-14195-00	.WASHER, valve seat		1	
261-14141-32	.NOZZLE, main	0-2	1	
248-14145-01	.SETTER, needle jet		1	
137-14153-00	.WASHER, main jet		1	
93210-04121	.O-RING		1	
137-14143-36	.JET, main	#180	} U. R 1	(S.T.D)
137-14143-38	.JET, main	#190		
137-14143-40	.JET, main	#200		
248-14198-00	.GASKET		1	
248-14166-00	.BOLT, banjo		1	
156-14185-00	.FLOAT		1	
137-14186-00	.PIN, float		1	
156-14184-00	.GASKET, float chamber		1	
248-14181-01	.BODY, float chamber		1	
204-14112-15	.VALVE, throttle	#1.5	1	
152-14116-15	.NEEDLE	4F 15-2	1	
164-14137-00	.CLIP		1	
246-14132-00	.STOPPER, cable		1	
248-14131-00	.SPRING, throttle valve		1	
802-14158-00	.TOP, mixing chamber		1	
802-14161-00	.NUT, wire adjusting		1	
127-14124-20	.SCREW, wire adjusting	20ℓ	1	
802-14169-00	.CAP		1	
137-14133-00	.SPRING, throttle stop		1	
204-14122-00	.SCREW, throttle		1	
127-14134-00	.SPRING, air adjusting		1	
152-14123-00	.SCREW, air adjusting		1	
132-14171-00	.PLUNGER, starter		1	
156-14135-00	.SPRING, plunger		1	

Parts No.	Parts Name	Description	Q'ty	Remarks
132-14179-00	. WASHER, starter lever		1	
214-14175-00	. LEVER, starter		1	
132-14174-00	. CAP, plunger		1	
132-14173-00	. COVER, plunger cap		1	
98502-04015	. SCREW, pan head	ISO	4	
92901-04100	. WASHER, spring		4	
170-14178-00	. PLATE, starter lever		1	
248-14147-00	. O-RING		1	
137-14197-00	PIPE, overflow		1	
97201-08030	BOLT	ISO	2	
92901-08100	WASHER, spring		2	
92901-08200	WASHER, plain		2	
248-13555-00	JOINT		1	
248-13556-70	GASKET		1	
248-81300-10	FLYWHEEL MAGNETO ASS'Y	ISO	1	
248-81350-10	. ROTOR ASS'Y		1	
185-81312-10	. COIL, source		1	
248-81313-10	. COIL, lighting		1	
110-81348-20	. SCREW, pan head	4-25 ISO	4	
92901-04100	. WASHER, spring		7	
185-81332-10	. PLATE, timing		1	
207-81321-10	. CONTACT BREAKER ASS'Y		1	
110-81347-20	. SCREW, cylinder head	4-12 ISO	1	
92901-04200	. WASHER, plain		1	
207-81326-10	. CONDENSER		1	
207-81331-10	. LUBRICATOR		1	
98501-04010	. SCREW, pan head	ISO	1	
109-81328-10	. CLAMP, lead		1	
98501-04008	. SCREW, pan head	ISO	1	
92701-06012	SCREW, flat head		2	
248-82310-10	IGNITION COIL ASS'Y		1	
183-82341-00	CORD, high-tension		1	

Parts No.	Parts Name	Description	Q'ty	Remarks
117-82370-20	PLUG CAP ASS'Y		1	
94700-00035	PLUG, spark	B-9E	1	
263-82319-00	WIRE, sub-lead		1	

### VIII-2 Modification of the Chassis

Modification of the chassis just requires the removal of the chassis components unnecessary for motocross.

○ Replace both front and rear tires with those of the motocross specification.

○ Choose the most suitable sprocket wheel for motocross.

Several types of sprocket wheels, varying in the number of teeth, are available at your Yamaha dealer's shop.

○ Remove all electrical components together with the wire harness, except for the magneto and ignition coil. As an option, the magneto of the racing specification available. (Refer to the List of Motocross Tuning Parts.)

○ Connect the black lead of the magneto to the same color lead of the ignition coil. It is advisable to use the following optional parts to make the AT1-C the full-equipped motocrosser.

Parts No.	Parts Name	Description	Q'ty	Remarks
263-23100-00-35	FRONT FORK ASS'Y		1	
214-21510-00-35	FRONT FENDER COMP.		1	
214-21512-00	BRACKET, fender		1	
214-21513-00	STAY, fender (L.H)		1	
214-21514-00	STAY, fender (R.H)		1	
248-22210-20	REAR CUSHION ASS'Y		2	
214-22241-00	BOLT, rear cushion		1	
248-21240-00-33	BATTERY BOX COMP.		1	
248-21757-00	WASHER, special		2	
263-21685-00-35	BRACKET, number plate		1	
97201-08050	BOLT	ISO	2	
92901-08100	WASHER, spring		2	

Parts No.	Parts Name	Description	Q'ty	Remarks
92901-08200	WASHER, plain		2	
91201-06012	BOLT		2	
92801-06100	NUT		2	
92901-06100	WASHER, spring		2	
263-21786-00	EMBLEM, motocros		1	
94132-18074	TIRE	3.25-18-4PR	1	For front
94232-18020	TUBE	3.25-18	1	For front
94332-18016	BAND, rim	3.25-18	1	For front
94416-18046	RIM	1.60A-18	1	For front
94135-18079	TIRE	3.50-18-4PR	1	For rear
94235-18022	TUBE	3.50-18	1	For rear
94335-18018	BAND, rim	3.50-18	1	For rear
94418-18045	RIM	1.85B-18	1	For rear
248-25443-10	GEAR, sprocket wheel	43-T	1	
248-25445-10	GEAR, sprocket wheel	45-T	1	(S.T.D)
248-25447-10	GEAR, sprocket wheel	47-T	1	

The AT1-MX is provided with these tuning parts.



---

### VIII-3 Service Data (AT1-MX specifications)

- Piston clearance..... 0.040-0.050 mm
- Piston ring end gap ..... 0.020" or less (0.5 mm or less)  
(when piston is fitted in cylinder)
- Spark plug ..... Standard B-9E
- Ignition timing..... 2.0 mm B.T.D.C.
- Carburetor setting ..... M. J. (Main jet) #190  
J. N. (Jet needle) 4F15-2 stages  
N. J. (Needle jet) 0-2  
C. A. (Throttle valve 1.5 cut-away)  
P. J. (Pilot jet) #30  
A. S. (Air screw) turns out 1½ turns
- Fuel mixing ratio ..... Autolube in use: 30 : 1 Oil in GAS.  
Autolube Disconnected: 15 : 1 Oil in GAS.

\* These tuning parts, optional parts and service data may be subject to change without advance notice.

When desiring any of these parts, consult your Yamaha dealer as to Their available.

### VIII-4 Change in Specifications

Participants in racing must change specifications of the machine depending on conditions of the racing course, road surface, soil, length of straight aways, angles of curves, number of curves, slopes, weather, temperatures, and skill of the rider. These factors and conditions must be determined by the rider himself after trial running over the whole race course. [legends-yamaha-enduros.com](http://legends-yamaha-enduros.com)

#### Main Points to be Modified

##### ○ Carburetor Setting

In addition to the specified M.J., the rider should carry with him spare M.J.s whose size numbers are larger and smaller than specified by 10, respectively.

##### ○ Secondary Reduction Ratio

Consideration should be given to a combination of the drive sprocket and sprocket wheel so that gear shifting to 3rd and 4th is easy.

##### ○ Plug

Change the plug by judging discoloration of the plug. Choose the most suitable

---

---

one from B-8E(N), B-9E(N) and B-10E(N).

○ Tire Pressure

Adjust the tire pressure, according to road conditions and the rider's choice.

○ Front Fork

Adjust the front fork by adjusting the quantity of oil. (The oil amount is in the range of 145 to 160 cc.)

Note: The 250 DT1 front fork can be used on the AT1 without modifying it.

○ Rear Cushions

Adjust the spring depending on the rider's choice. It is possible to use the DT1 rear cushions for the AT1 without modifying them.

○ Handlebar

Loosen the handle lever holder before racing. It will protect the rider's hands or fingers from getting injured, in case of an accidental crash during the race. (The lever can easily turn when the machine turns over.)

### VIII-5 Miscellaneous Notes

Racing requires the severest operation of the machine as well as high performance and extra durability.

Accordingly, thorough inspection and service of the machine before racing are very important. In particular, the engine will be operated at high speeds for many consecutive hours. Hence, even a minor defect may result in engine troubles. Be sure to check and service the machine with special care prior to racing.

The newly tuned up engine must be handled in the same manner as a brand new machine, so it requires a certain period of braking-in.

○ The racer should devote the maximum possible time to inspection and service of the machine prior to racing. "Thorough inspection and service are the first step to victory."

Note:

- 1) These parts may be subject to change in specifications (part numbers, setting values, etc.). When using them, consult your Yamaha dealer.

The AT1-MX is provided with these tuning parts. (Front tire size is 3.25-18)

---

# CONVERSION TABLES

## LENGTHS

Multiply	By To Obtain	Multiply	By To Obtain
Millimeters (mm)	0.03937 Inches	Kilometers (km.)	.6214 Miles
Inches (in.)	25.4 Millimeters	Miles (mi.)	1.609 Kilometers
Centimeters (cm.)	.3937 Inches	Meters (m.)	3.281 Feet
Inches (in.)	2.54 Centimeters	Feet (ft.)	.3048 Meters

## WEIGHTS

Kilograms (kg.)	2.205 Pounds	Grams (g.)	.03527 Ounces
Pounds (lbs.)	.4536 Kilograms	Ounces (oz.)	28.35 Grams

## VOLUMES

Cubic centimeters (c.c.)	.061 Cubic inches	Imperial gallons	277.274 cu. in.
Cubic inches (cu. in.)	16.387 c.c.	Liters (l.)	1.057 Quarts
Liters (l.)	.264 Gallons	Quarts (qt.)	.946 Liters
Gallons (gal.)	3.785 Liters	Cubic centimeters (c.c.)	.0339 Fluid ounces
U. S. gallons	1.2 Imperial gals.	Fluid ounces (fl. oz.)	29.57 c.c.
Imperial gallons	4.537 Liters		

## OTHERS

Metric horsepower (ps.)	1.014 bhp.	Foot-pounds (ft-lb)	.1383 kg-m
Brake horsepower (bhp.)	.9859 ps.	Kilometers per liter(km/l)	2.352 mpg
Kilogram-meter (kg-m)	7.235 ft-lb	Miles per gallon (mpg)	.4252 km/l

## GAS (FUEL) TO OIL RATIO CHART

Gas/Oil Ratio	12:1	16:1	20:1	24:1	28:1	32:1	36:1	40:1
Oil (qt.) per 1 Gal. Gas	0.33	0.25	0.2	0.17	0.14	0.13	0.11	0.1
Oil (oz.) per 1 Gal. Gas	10.7	8.0	6.4	5.3	4.6	4.0	3.6	3.2
Oil (qt.) per 5 Gal. Gas	1.66	1.25	1.0	0.84	0.72	0.63	0.55	0.5
Oil (oz.) per 5 Gal. Gas	53.5	40.0	32.0	26.6	22.8	20.0	17.8	16.0

(U.S. Gallons)

M E M O

A series of horizontal dashed lines for writing.

[www.legends-yamaha-enduros.com](http://www.legends-yamaha-enduros.com)

M E M O

[www.legends-yamaha-enduros.com](http://www.legends-yamaha-enduros.com)

M E M O

A series of horizontal dashed lines for writing.

[www.legends-yamaha-enduros.com](http://www.legends-yamaha-enduros.com)

M E M O

[www.legends-yamaha-enduros.com](http://www.legends-yamaha-enduros.com)

# M E M O

[www.legends-yamaha-enduros.com](http://www.legends-yamaha-enduros.com)



M E M O

[www.legends-yamaha-enduros.com](http://www.legends-yamaha-enduros.com)

YAMAHA MOTOR CO. LTD.  
YAMAMATSU JAPAN

YAMAHA 125 AT1-C & AT1-MX

**Service manual**



[www.legends-yamaha-enduros.com](http://www.legends-yamaha-enduros.com)  
**YAMAHA MOTOR CO., LTD.**

**HAMAMATSU, JAPAN**

# YAMAHA AT1-C WIRING DIAGRAM

Chart of wire colors

Armature Circuit	white
Field Circuit	green
Earth Circuit	black
Common Circuit.	brown
Battery (+) Circuit	red
Lamp Circuit	blue
Horn Circuit	pink
Neutral Lamp Circuit	sky blue
Tail Lamp Circuit	blue
Ignition Coil Circuit	orange
Stop Lamp Circuit	yellow
Starter Switch Circuit	blue-white
Starter Circuit	light green
Flasher Light (Right) Circuit	light green
Flasher Light (Left) Circuit	dark green
Flasher Switch Circuit	dark brown
Flasher Switch Circuit	brown-white

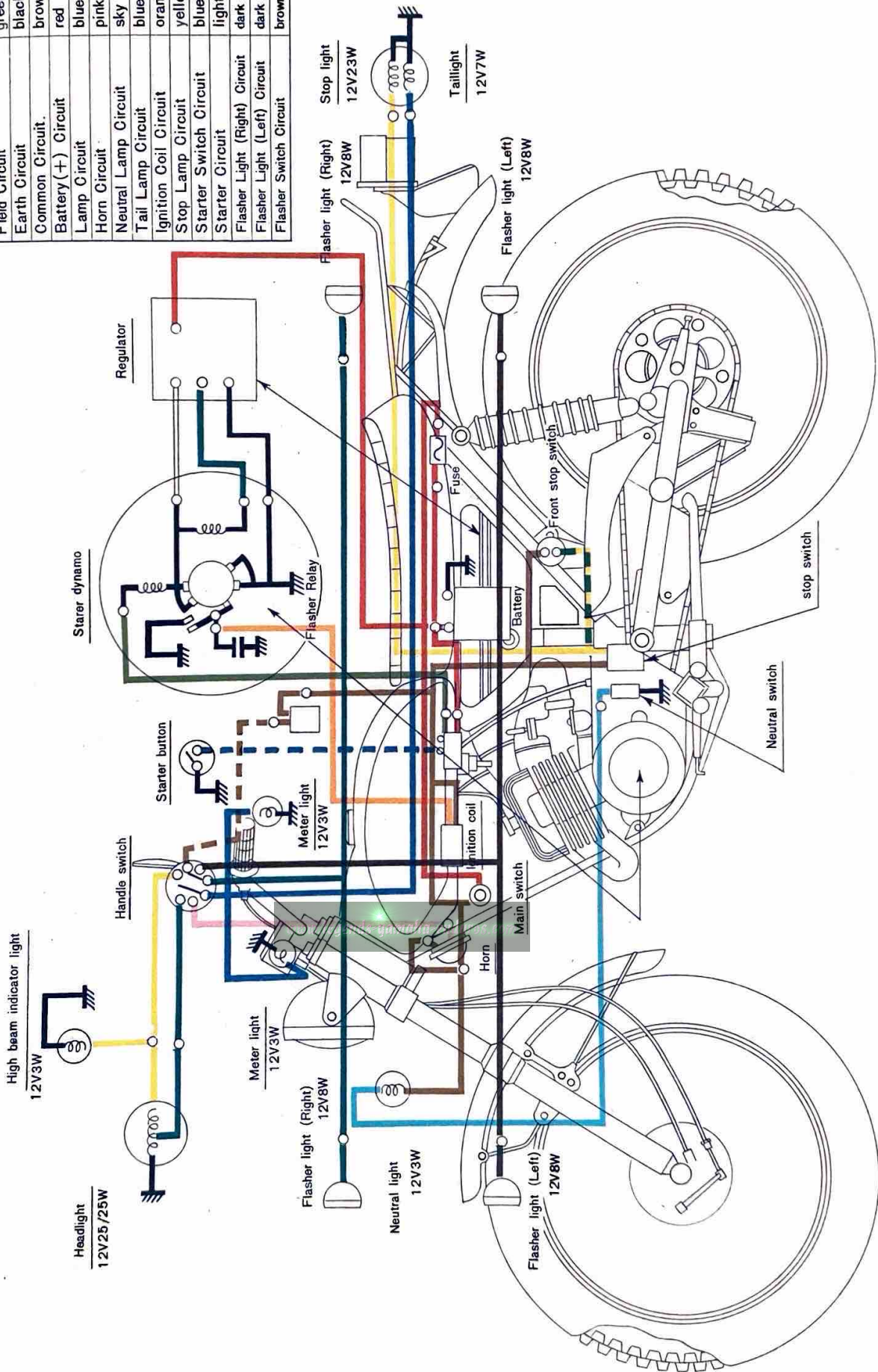

[www.legends-yamaha-enduros.com](http://www.legends-yamaha-enduros.com)



**YAMAHA MOTOR CO., LTD.**

Printed in Japan