



YAMAHA

GENUINE

PARTS CATALOGUE

MOTORCYCLE

www.legends-yamaha-enduros.com

CYLINDER HEAD - CYLINDER

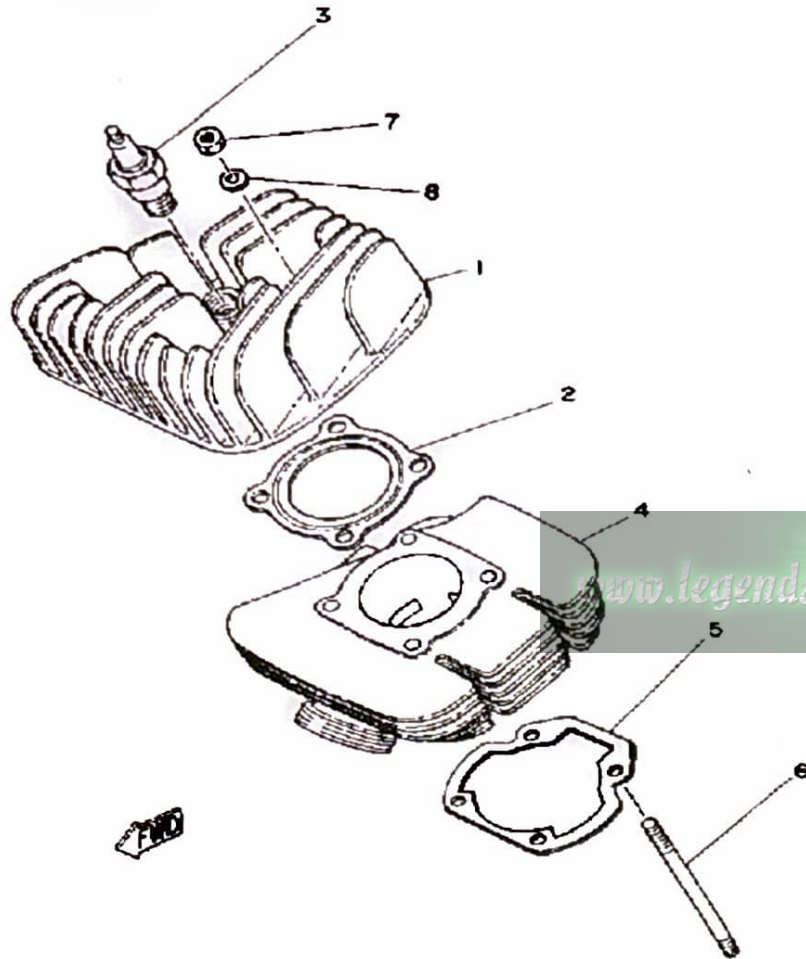

Ref. No.	Part Number	Description	Qty	Remarks
1	367-11111-01-R4	HEAD, CYLINDER 1	1	BLACK
2	1F5-11181-00-00	GASKET, CYLINDER HEAD 1 . . .	1	
3	NGK-B7HS0-00-00	PLUG, SPARK (B6HS)	1	
4	367-11311-00-00	CYLINDER 1	1	
5	367-11351-00-00	GASKET, CYLINDER	1	
6	90116-06026-00	BOLT, STUD	4	
7	95380-06600-00	NUT	4	
8	92990-06200-00	WASHER, PLAIN	4	

CRANKSHAFT - PISTON

Ref. No.	Part Number	Description	Qty	Remarks
1	1K9-11400-00-00	CRANKSHAFT ASSEMBLY ...	1	
2	598-11412-00-00	. CRANK 1	1	
3	(598-11422-00-00)	CRANK 2	1	
4	538-11650-01-00	. CONNECTING ROD ASSEMBLY	1	ASSEMBLY
5	3R1-11651-01-00	.. ROD, CONNECTING	1	
6	257-11681-00-00	.. PIN, CRANK 1	1	
7	90209-18112-00	.. WASHER, SPEC'L SHAP ..	2	
8	93310-418T0-00	.. BEARING, CYLINDRICAL	1	
9	93310-11268-00	. BEARING	1	
10	367-11630-51-00	PISTON KIT STD	1	ASSEMBLY
11	367-11631-00-96	. PISTON STD	1	
12	367-11610-00-00	. PISTON RINGSET STD	1	
13	527-11633-00-00	. PIN, PISTON	1	
14	93450-13022-00	. CIRCLIP	2	
15	(93306-20410-00)	BEARING	2	
16	93102-20009-00	OIL SEAL	1	
17	93103-28011-00	OIL SEAL	1	
	93103-29011-00	UNAVAILABLE IN PRICE BOOK	1	
18	90387-205E9-00	COLLAR	1	
19	90280-03017-00	KEY, WOODRUFF	1	
20	90170-12175-00	NUT	1	
21	92901-12100-00	WASHER, SPRING	1	
22	(367-11630-91-00)	PISTON KIT 4TH	1	
	367-11610-10-00	PISTON RINGSET 1ST	1	
	367-11610-20-00	PISTON RINGSET 2ND	1	
	367-11610-30-00	PISTON RINGSET 3RD	1	
	367-11610-40-00	PISTON RINGSET 4TH	1	
	367-11630-61-00	PISTON KIT 1ST	1	

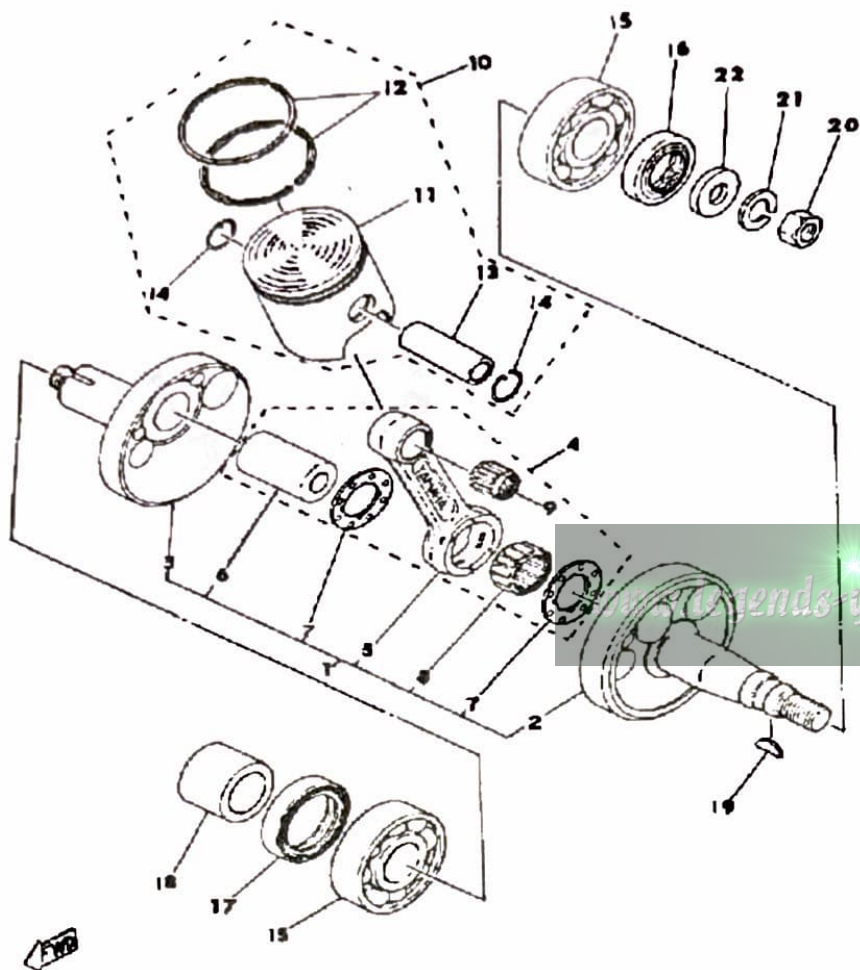

CONTINUED ON NEXT FRAME ►

CRANKSHAFT - PISTON

Ref. No.	Part Number	Description	Qty	Remarks
22	367-11630-71-00	PISTON KIT 2ND	1	
	367-11630-81-00	PISTON KIT 3RD O/S	1	
	367-11635-11-00	PISTON 1 O/S 0.5	1	
	367-11636-11-00	PISTON 2 O/S 0.0	1	
	367-11637-11-00	PISTON 3 O/S 0.5	1	
	367-11638-11-00	PISTON 4 O/S 1.0	1	
	90201-12535-00	WASHER, PLATE	1	

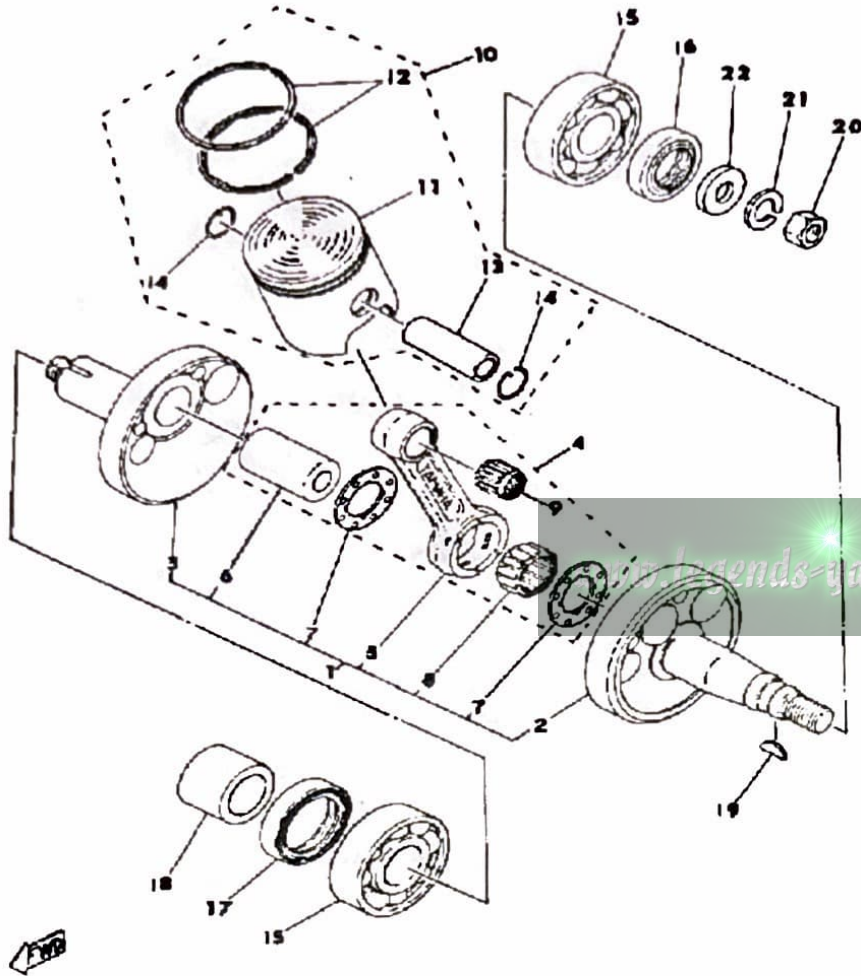

FLYWHEEL MAGNETO

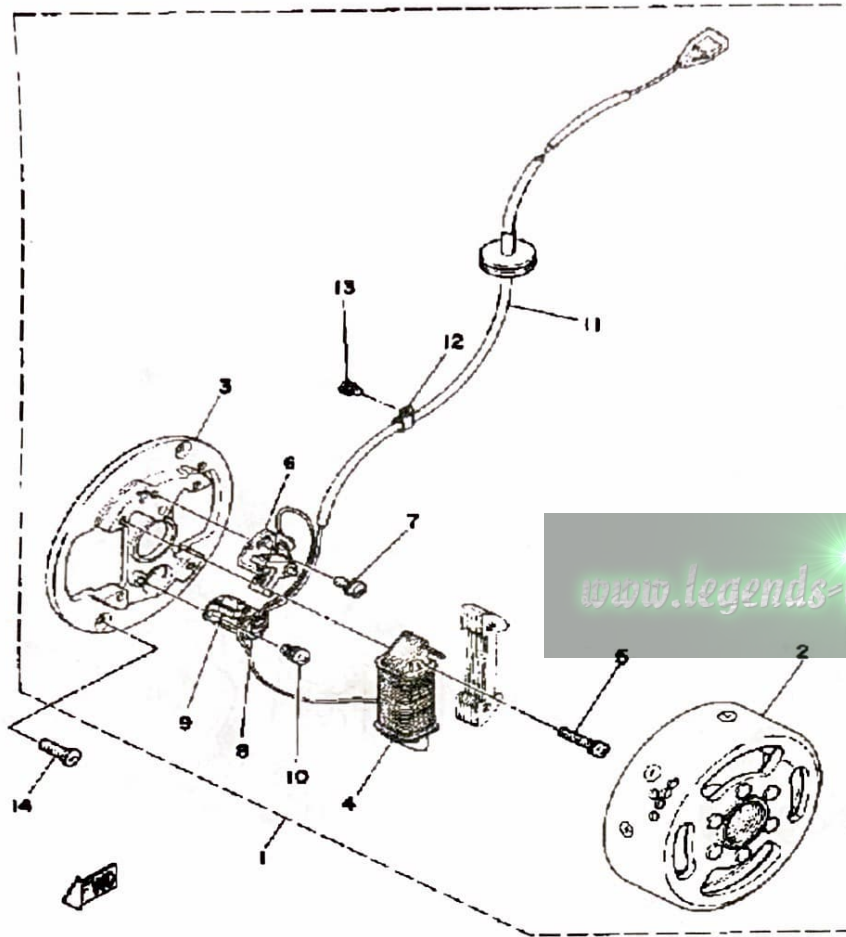

Ref. No.	Part Number	Description	Qty	Remarks
1	1T0-81300-20-00	FLYWHL MAGNETO ASSEMBLY (367-81300-21-00)	1	
2	(1T0-81350-20-00)	ROTOR ASSEMBLY	1	
3	520-81309-20-00	. BASE, MAGNETO	1	
4	511-81312-20-00	. COIL, SOURCE	1	
5	97602-04125-00	. SCREW, PN/HD.W/WSHR (4-25)	2	
6	2A6-81321-20-00	. CONTACT BRKR ASSEMBLY	1	
7	110-81346-21-00	. SCREW, PAN HEAD	1	
8	1K8-81325-20-00	. CONDENSER 1	1	
9	116-81331-20-00	. LUBRICATOR	1	
10	110-81346-21-00	. SCREW, PAN HEAD	1	
11	(367-81315-20-00)	LEAD WIRE ASSEMBLY	1	
12	(367-81328-20-00)	CLAMP	1	
13	97601-04106-00	. SCREW, PN/HD.W/WSHR	1	
14	98701-05016-00	SCREW, FLAT HEAD	2	

OIL PUMP

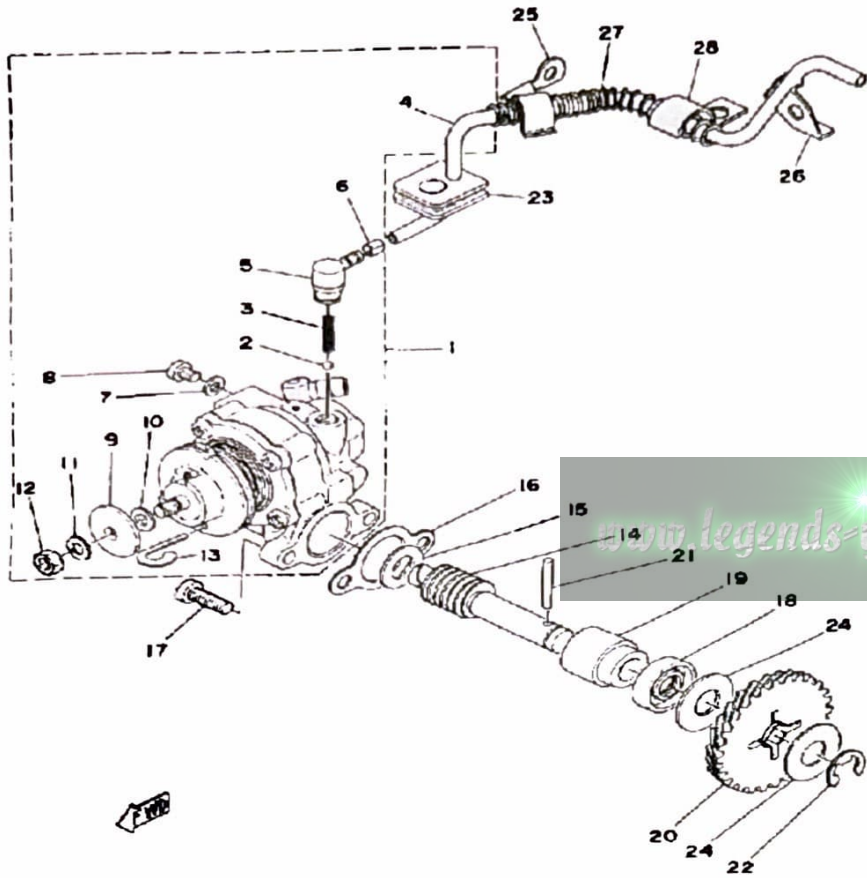

Ref. No.	Part Number	Description	Qty	Remarks
1	(1K8-13101-01-00)	OIL PUMP ASSEMBLY	1	
2	93505-32002-00	. BALL	1	
3	90501-02217-00	. SPRING, COMPRESSION	1	
4	90445-05278-00	. HOSE	1	
5	353-13552-01-00	. NOZZLE	1	
6	90468-02033-00	. CLIP	1	
7	90430-04004-00	. GASKET	1	
8	98901-04008-00	. SCREW, BIND	1	
9	137-13138-01-00	. PLATE, ADJUSTING	1	
10	137-13137-00-03	. SHIM (0.3T)	1	U.R.
	137-13137-00-05	. SHIM (0.5T)	1	U.R.
	137-13137-00-10	. SHIM (1.0T)	1	U.R.
11	92990-05100-00	. WASHER, SPRING	1	
12	95380-05600-00	. NUT	1	
13	367-13146-01-00	. CLIP	1	
14	257-13175-00-00	SHAFT, WORM	1	
15	90201-08624-00	WASHER, PLATE	1	
16	3MT-13116-00-00	GASKET, PUMP CASE (8Y0-13116-00)	1	
17	98580-05016-00	SCREW, PAN HEAD	2	
18	93101-10090-00	OIL SEAL	1	
19	1E7-13176-00-00	METAL, WRM SHAF OTR	1	
20	353-13178-00-00	GEAR, PUMP DRIVE	1	
21	93603-22028-00	PIN, DOWEL	1	
22	99001-08600-00	CIRCLIP	1	
23	248-13174-00-00	HOLDER, OIL PIPE	1	
24	90201-105J4-00	WASHER, PLATE (90201-106H1)	2	
25	367-13174-00-00	HOLDER, OIL PIPE	1	

CONTINUED ON NEXT FRAME ►

OIL PUMP

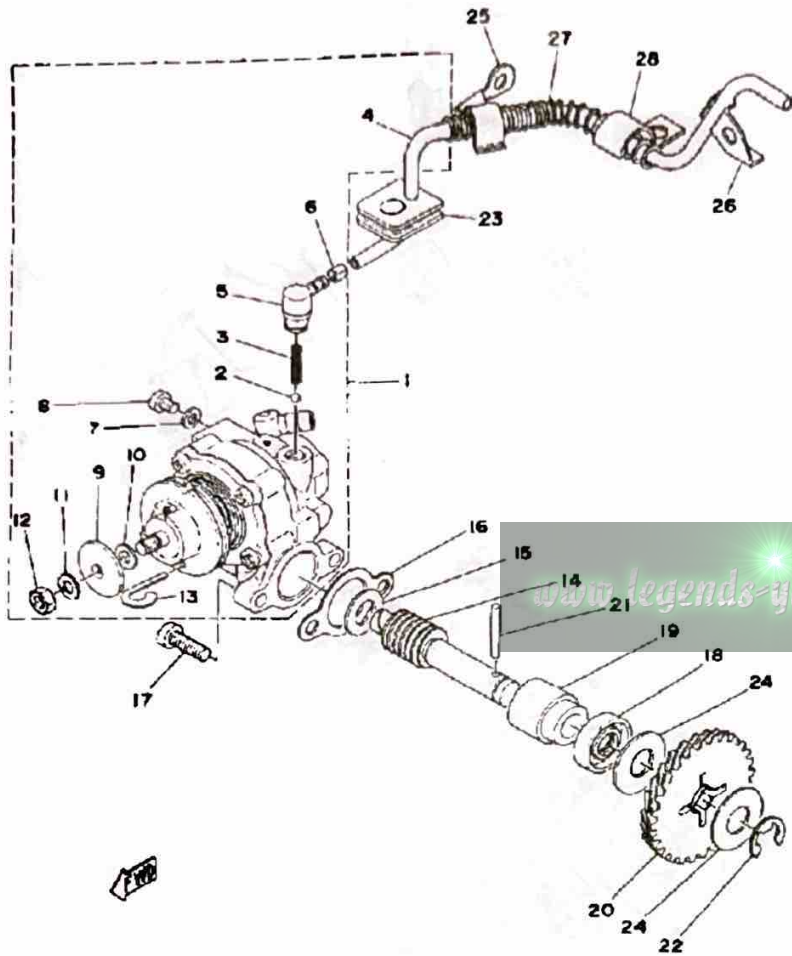

Ref. No.	Part Number	Description	Qty	Remarks
26	(367-15378-00-00)	HOLDER	1	
27	90501-06025-00	SPRING, COMPRESSION	1	
28	90462-06009-00	CLAMP	1	

INTAKE

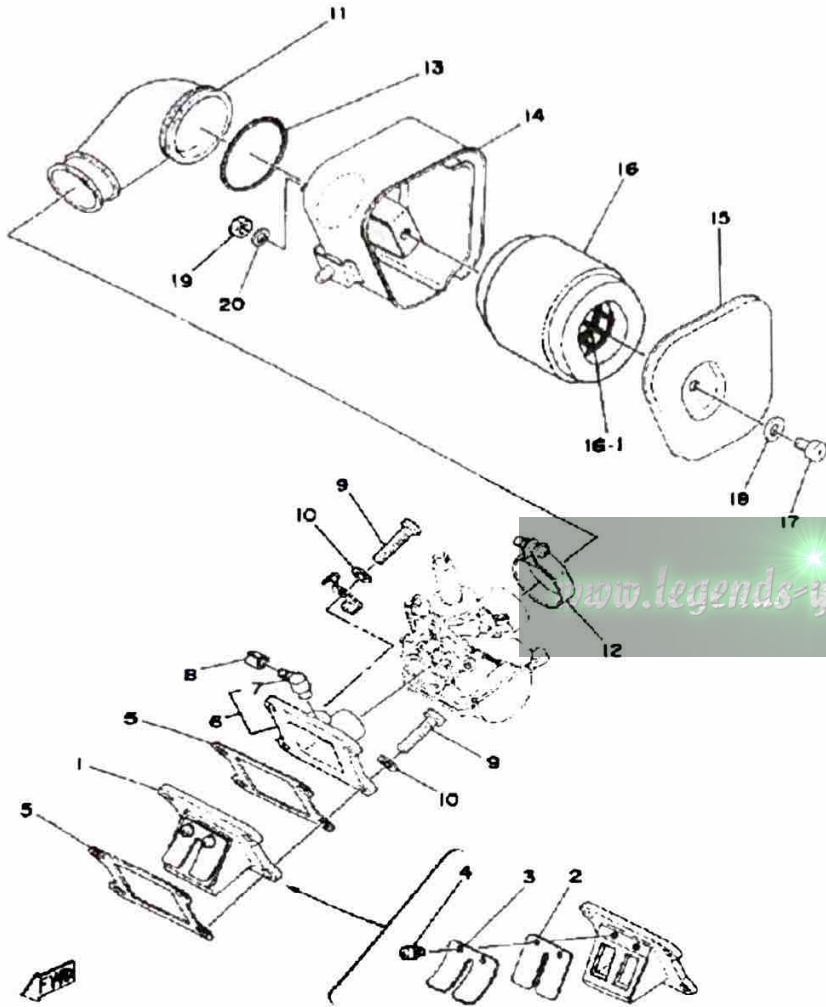

Ref. No.	Part Number	Description	Qty	Remarks
1	353-13610-01-00	REED VALVE ASSEMBLY	1	
2	314-13613-01-00	. REED, VALVE	1	
3	314-13616-01-00	. STOPPER, REED VALVE	1	
4	98580-03008-00	. SCREW, PAN HEAD	2	
5	3MT-13621-00-00	GASKET, VALVE SEAT	2	
6	374-13565-00-00	JOINT, CARBURETOR (367-13565-00-98)	1	SILVER
7	278-13552-02-00	. NOZZLE (278-13552-01) 0 1	1	
8	90468-02033-00	CLIP	1	
9	98511-06025-00	SCREW PAN HEAD (92501-06025)	4	
10	92995-06100-00	WASHER, SPRING	4	
11	367-14453-02-00	JOINT, AIR CLNR 1	1	
12	90460-33087-00	CLAMP, HOSE	1	
13	90506-06075-00	SPRING, TENSION	1	
14	367-14411-00-00	CASE, AIR CLEANER 1	1	
15	2A3-14412-00-00	CAP, CLEANER CASE 1	1	
16	367-14451-09-00	ELEMENT, AIR CLNR	1	
17	98580-06010-00	SCREW, PAN HEAD (92503-06010)	1	
18	92990-06200-00	WASHER, PLAIN	1	
19	95380-06600-00	NUT	2	
20	92995-06100-00	WASHER, SPRING	2	
16-1	367-14451-09-00	ELEMENT, AIR CLNR	1	

CARBURETOR

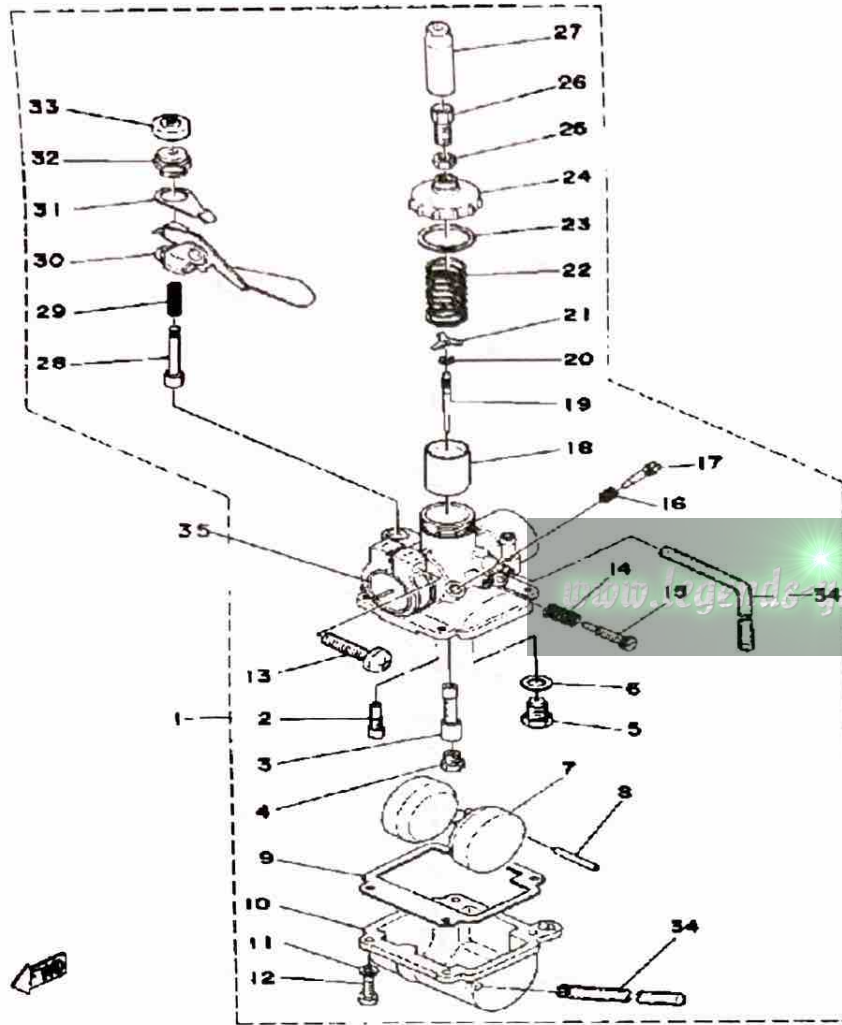

Ref. No.	Part Number	Description	Qty	Remarks
1	367-14301-61-00	CARBURETOR ASSEMBLY 1	1	
2	367-14342-17-00	. JET, PILOT # 4	1	
3	288-14341-02-00	. NOZZLE, MAIN	1	
4	288-14343-46-00	. JET, MAIN # 2	1	U.R.
	288-14343-47-00	. JET, MAIN # 4	1	U.R. STD
	288-14343-48-00	. JET, MAIN # 6	1	U.R.
5	367-14390-14-00	. NEEDLE VALVE ASSEMBLY	1	
6	367-14195-00-00	. GASKET	1	
7	367-14385-00-00	. FLOAT	1	
8	367-14386-00-00	. PIN, FLOAT	1	
9	4U1-14384-00-00	. GSKT, FLOAT CHAMBER	1	
10	(1G5-14381-25-00)	BODY, FLOAT CHAMBER	1	
11	92901-04100-00	. WASHER, SPRING	4	
12	98511-04012-00	. SCREW, PAN HEAD	4	
13	98511-06025-00	. SCREW PAN HEAD (92501-06025)	1	
14	646-14212-01-00	. SPRING, PILOT ADJUSTING	1	
15	646-14211-02-00	. SCREW, PILOT ADJUSTING	1	
16	367-14337-00-00	. SPRING, AIR ADJUST	1	
17	396-14323-00-00	. SCREW, AIR ADJUSTING	1	
18	367-14312-10-00	. VALVE, THROTTLE 1	1	
19	388-14336-03-00	. UNAVAILABLE IN PRICE BOOK	1	
20	288-14137-00-00	. CLIP	1	
21	367-14136-02-00	. SEAT, SPRING (367-14136-00)	1	
22	367-14331-00-00	. SPRING, THRTL VALVE	1	
23	367-14126-00-00	. GASKET	1	
24	367-14168-00-00	. CAP, MIXING CHAMBER	1	
25	288-14161-00-00	. NUT, CABLE ADJUSTING	1	

CONTINUED ON NEXT FRAME ►

CARBURETOR

Ref. No.	Part Number	Description	Qty	Remarks
26	288-14124-00-00	. SCREW, CABLE ADJUSTING	1	
27	367-14169-00-00	. CAP	1	
28	367-14371-00-00	. PLUNGER, STARTER	1	
29	367-14335-00-00	. SPRING, PLUNGER	1	
30	367-14375-01-00	. LEVER, STARTER	1	
31	367-14377-00-00	. STOPPER	1	
32	367-14374-00-00	. CAP, PLUNGER	1	
33	(367-14373-00-00)	COVER, PLUNGER CAP	1	
34	367-14396-00-00	. PIPE	2	
35	367-14156-00-00	GASKET, INSULATING	1	

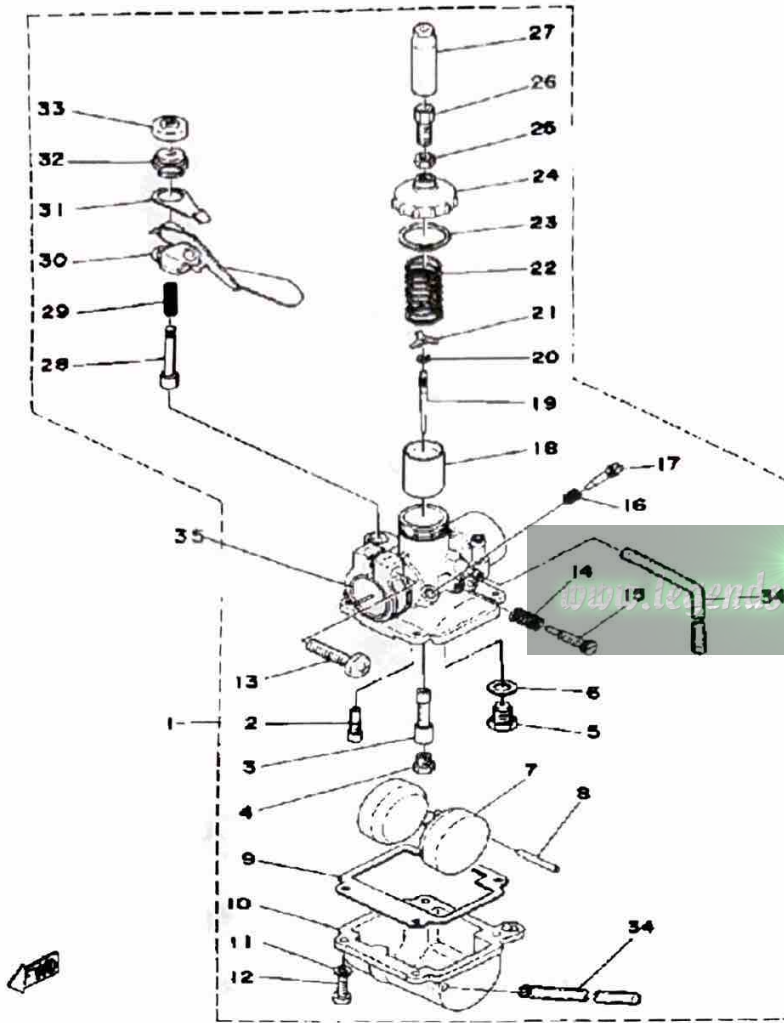

EXHAUST

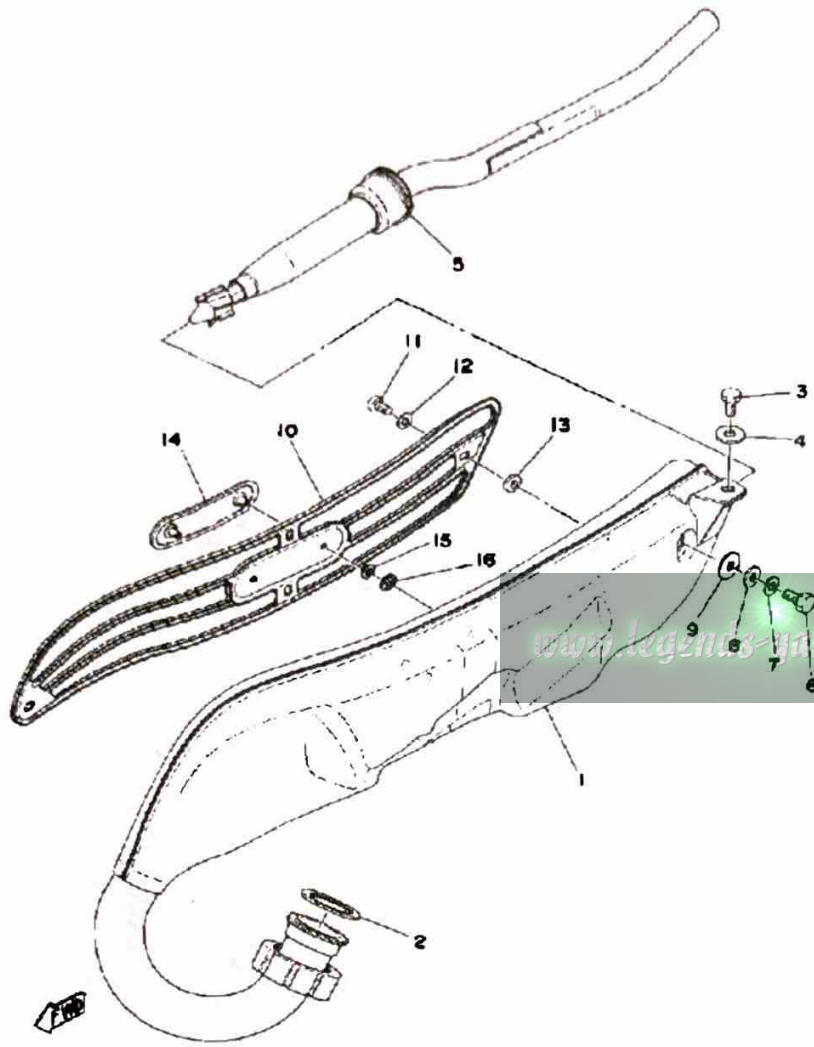

Ref. No.	Part Number	Description	Qty	Remarks
1	(367-14610-31-00)	EXHAUST PIPE ASSEMBLY L	1	
2	132-14613-00-00	GASKET, EXST PIPE	1	
3	97313-08018-00	BOLT, HEXAGON (97301-08016)	1	
4	92901-08600-00	WASHER	1	
5	367-14752-30-00	PIPE, OUTLET	1	
6	97313-06016-00	BOLT, HEXAGON	1	
7	92995-06100-00	WASHER, SPRING	1	
8	90201-06M08-00	WASHER, PLATE	1	
9	90430-05010-00	GASKET	1	
10	367-14718-30-00	PROTECTOR, MUFF 1	1	
11	98903-06010-00	SCREW, BIND	4	
12	90202-05187-00	WASHER, PLATE	4	
13	90202-05005-00	WASHER, PLATE (218-14766-10)	4	
14	367-14729-31-00	EMBLEM, PROTECTOR	1	
15	90202-04003-00	WASHER, PLATE	2	
16	90183-04005-00	NUT, SPRING	2	

CRANKCASE

Ref. No.	Part Number	Description	Qty	Remarks
1	(374-15111-00-00)	CRANKCASE 1	1	
2	98580-06550-00	SCREW PAN HEAD (92503-06050)	8	
3	98580-06055-00	SCREW, pan head (92501-06065-00)	1	
4	98511-06025-00	SCREW PAN HEAD (92501-06025)	2	
5	99510-12016-00	PIN, DOWEL	2	
6	90334-12009-00	PLUG, STRAIGHT	2	
7	374-15121-02-00	CRANKCASE 2	1	
8	492-15387-00-00	STOPPER	1	
9	90340-12005-00	PLUG, DRAIN	1	
10	90430-12207-00	GASKET	1	

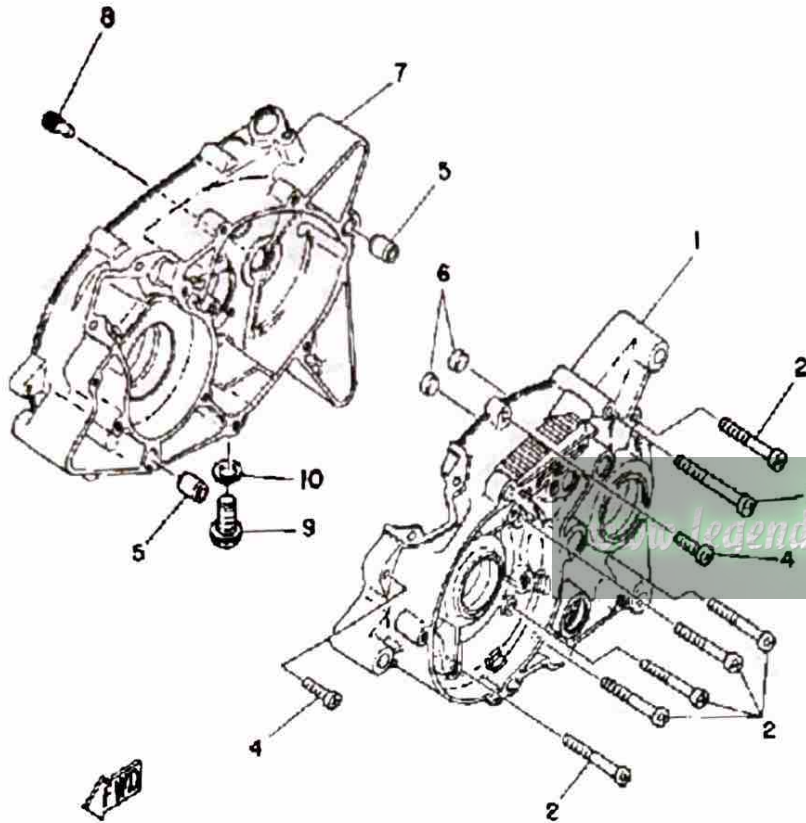

CRANKCASE COVER

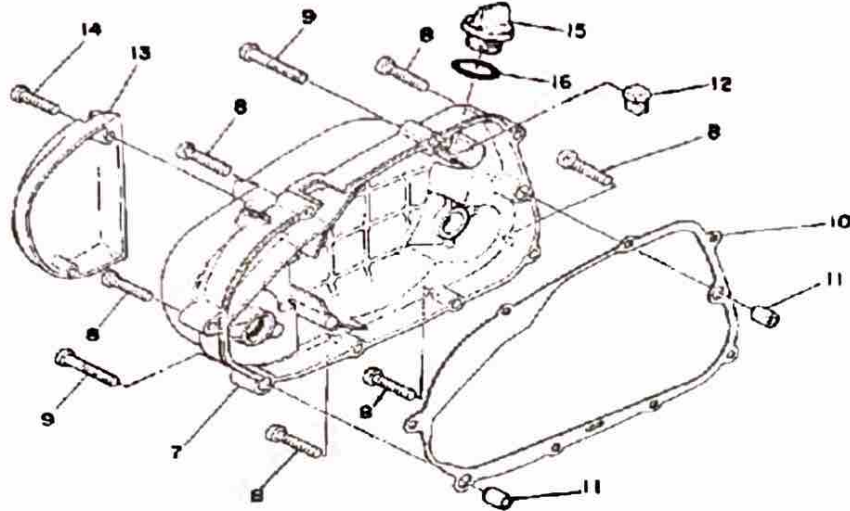

Ref. No.	Part Number	Description	Qty	Remarks
1	353-15411-00-98	COVER, CRANKCASE L	1	LOW GLOSS BLK
2	98516-06030-00	SCREW, PAN HEAD	3	
3	98506-06045-00	SCREW, PAN HEAD	1	
4	99530-10014-00	PIN, DOWEL	2	
5	353-15415-00-98	COVER, GENERATOR	1	LOW GLOSS BLK
6	98516-06020-00	SCREW, PAN HEAD	3	
7	353-15421-09-00	COVER, CRANKCASE R	1	LOW GLOSS BLK
8	98516-06030-00	SCREW, PAN HEAD	7	
9	98506-06040-00	SCREW, PAN HEAD	2	
10	3MT-15451-00-00	GASKET, CRCS COVER (353-15451-00)	1	
11	99530-10014-00	PIN, DOWEL	2	
12	353-15437-02-00	SCRAPER, OIL	1	
13	(353-15416-00-98)	COVER, OIL PUMP	1	LOW GLOSS BLK
14	98506-06025-00	SCREW, PAN HEAD	2	
15	1RG-15363-00-00	PLUG, OIL	1	
16	93210-21190-00	O-RING	1	

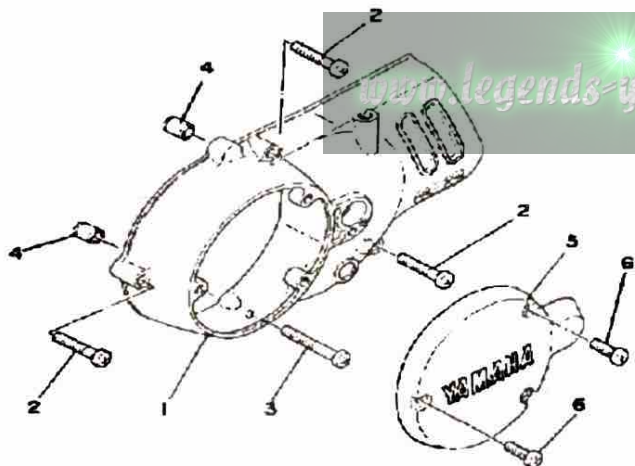

KICK STARTER

Ref. No.	Part Number	Description	Qty	Remarks
1	353-15660-01-00	KICK AXLE ASSEMBLY	1	
2	353-15641-00-00	GEAR, KICK	1	
3	90468-26038-00	CLIP	1	
4	90201-253K0-00	WASHER, PLATE (T=1.0)	1	
5	93410-25017-00	CIRCLIP	1	
6	132-15664-01-00	GUIDE, SPRING	1	
7	90508-26136-00	SPRING, TORSION	1	
8	132-15676-01-00	COVER, SPRING	1	
9	99009-15400-00	CIRCLIP	1	
10	93109-15001-00	OIL SEAL	1	
11	248-15668-00-00	STOPPER	1	
12	353-15651-00-00	GEAR, KICK IDLE	1	
13	90201-13202-00	WASHER, PLATE	1	
14	90206-15021-00	WASHER, WAVE	1	
15	90201-12M34-00	WASHER, PLATE	1	
16	99009-12400-00	CIRCLIP	1	
17	3AY-15620-00-00	KICK CRANK ASSEMBLY	1	UNI CHROME
18	(214-15612-09-00)	LEVER, KICK	1	
19	93440-10028-00	CIRCLIP, OUTER (132-15617-00)	1	
20	90504-18031-00	SPRING, COMPRESSION (132-15625-01)	1	
21	90209-10108-00	WASHER, SPEC'L SHAP	1	
22	156-15618-01-00	COVER, KICK LEVER	1	
23	97011-06025-00	BOLT (97001-06025)	1	

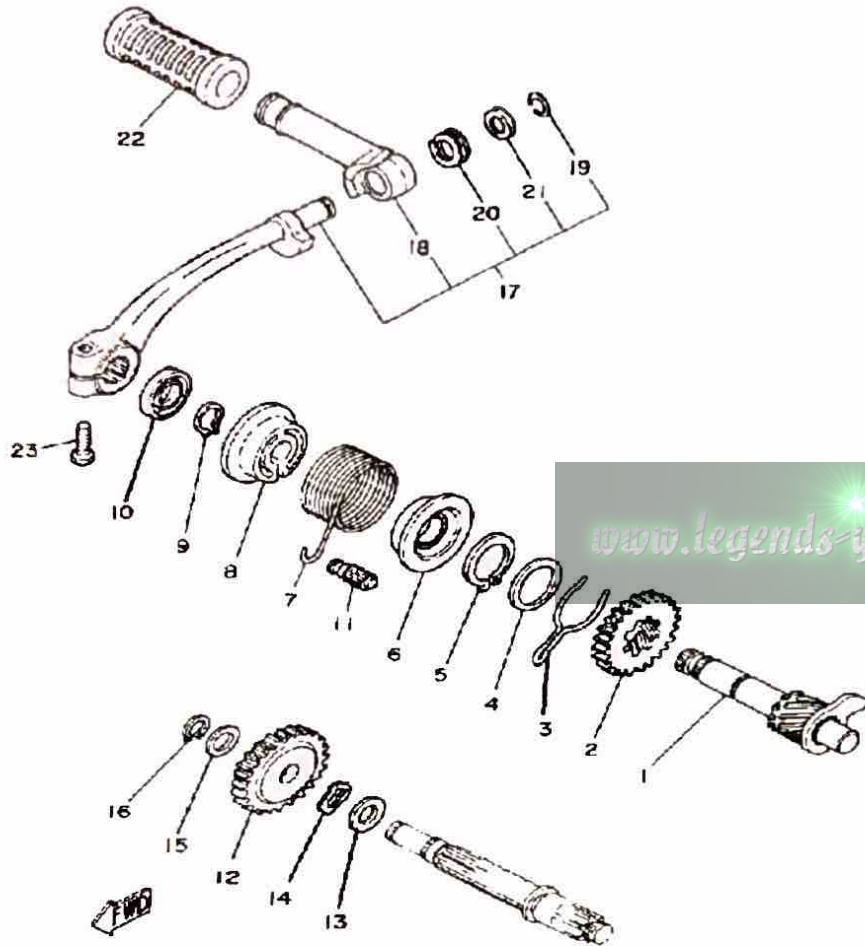

CLUTCH

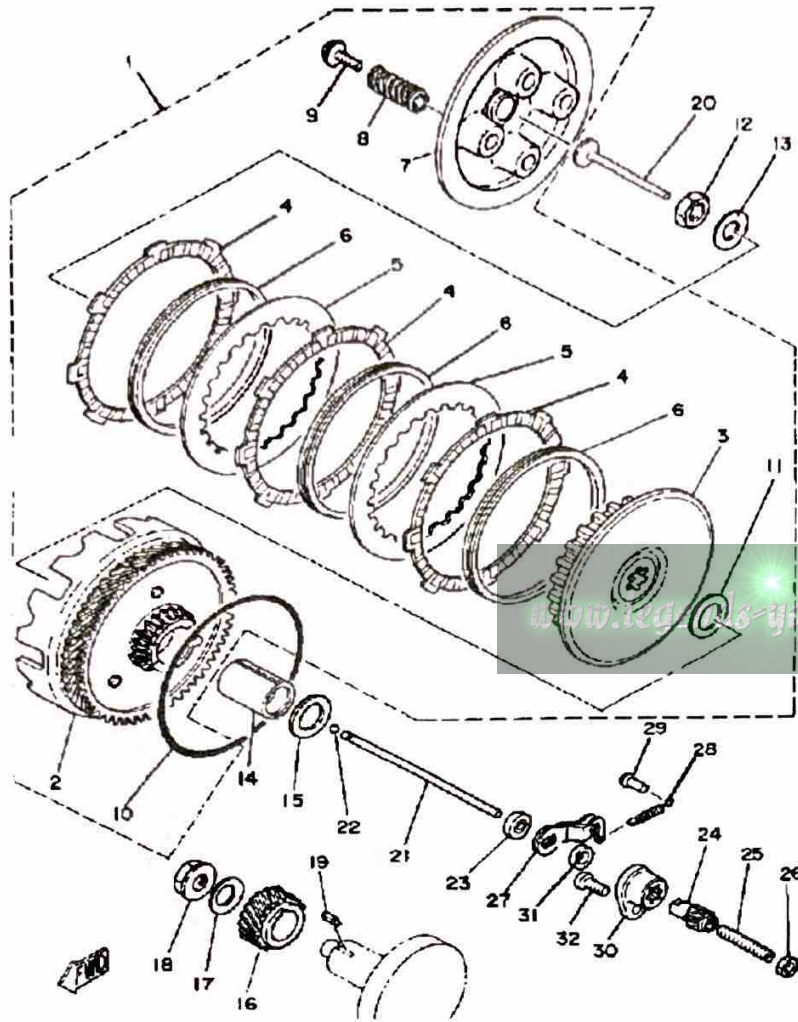

Ref. No.	Part Number	Description	Qty	Remarks
1	(2A3-16301-00-00)	CLUTCH ASSEMBLY	1	
2	1T0-16150-01-00	. PRI.DRVN.GEAR COMP. (68T) (2A3-16150-00)	1	
3	353-16371-00-00	. BOSS, CLUTCH	1	
4	131-16321-00-00	. PLATE, FRICTION	3	
5	257-16324-00-00	. PLATE, CLUTCH 1	2	
6	131-16367-00-00	. RING, CUSHION	3	
7	353-16351-00-00	. PLATE, PRESSURE 1	1	
8	90501-20125-00	. SPRING, COMPRESSION	4	
9	90119-05001-00	. BOLT, WITH WASHER	4	
10	93210-98202-00	. O-RING	1	
11	122-16164-00-00	. PLATE, THRUST 2	1	
12	90170-12060-00	NUT	1	
13	90208-12015-00	WASHER, CONICAL SPRING	1	
14	90560-17123-00	SPACER	1	
15	122-16164-00-00	PLATE, THRUST 2	1	
16	353-16111-01-00	GEAR, PRI DRIVE	1	
17	90208-12015-00	WASHER, CONICAL SPRING	1	
18	90179-12244-00	NUT, SPEC'L SHAPE	1	
19	90282-05005-00	KEY, STRAIGHT	1	
20	137-16356-00-00	ROD, PUSH 1	1	
21	353-16357-00-00	ROD, PUSH 2	1	
22	93503-16010-00	BALL	1	
23	93102-04382-00	OIL SEAL, SD-TYPE (257-153879-00)	1	
24	241-16341-01-00	SCREW, PUSH	1	
25	90113-06013-00	BOLT, SET	1	
26	95380-06700-00	NUT	1	
27	451-16342-00-00	LEVER, PUSH	1	

CONTINUED ON NEXT FRAME ►

CLUTCH

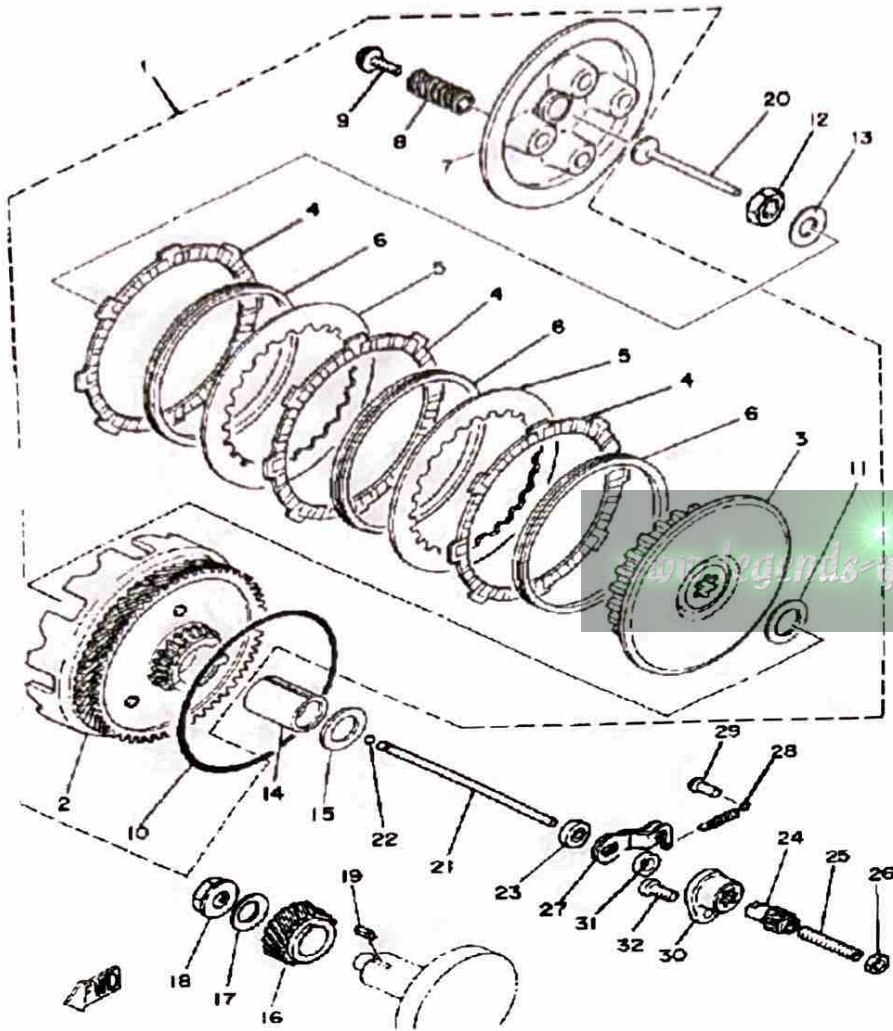

Ref. No.	Part Number	Description	Qty	Remarks
28	90506-07066-00	SPRING, TENSION	1	
29	132-16346-00-00	HOOK, SPRING	1	
30	353-16396-00-00	HOUSING, PUSH SCREW	1	
31	93104-10085-00	OIL SEAL, SO-TYPE	1	
32	98503-06014-00	SCREW, PAN HEAD (92502-06016)	1	

TRANSMISSION

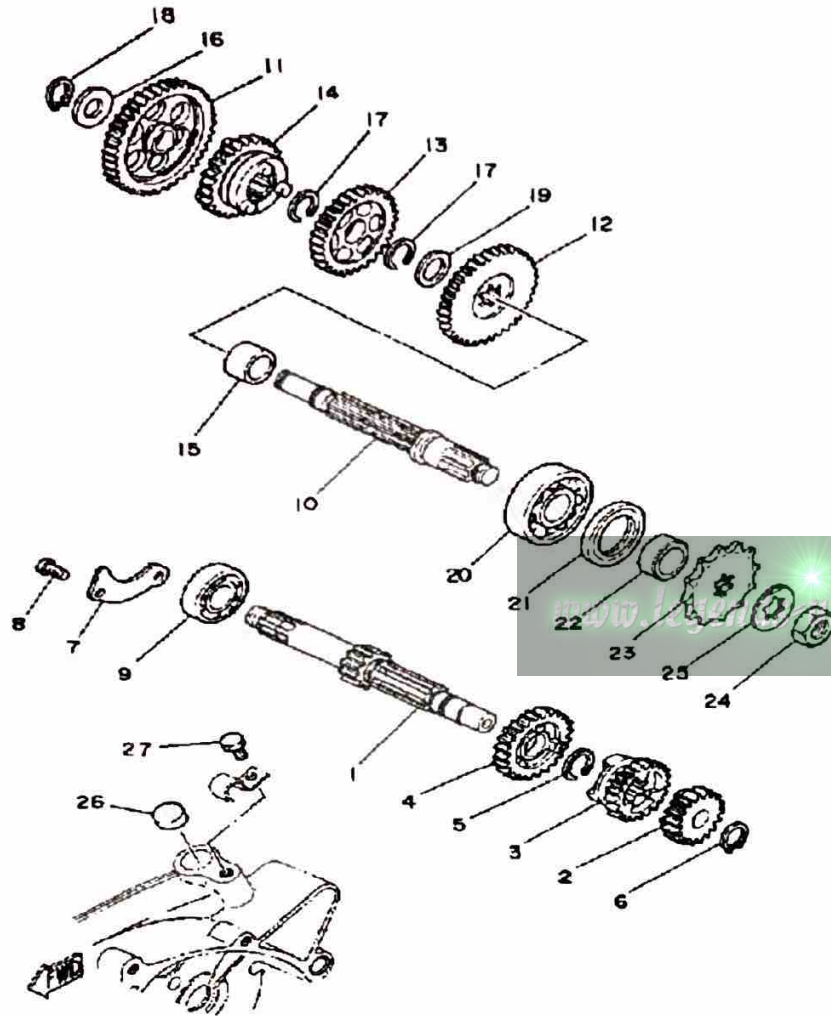

Ref. No.	Part Number	Description	Qty	Remarks
1	353-17411-10-00	AXLE, MAIN	1	
2	353-17121-11-00	GEAR, 2ND PINION	1	
3	353-17131-10-00	GEAR, 3RD PINION	1	U.R.
4	353-17141-12-00	GEAR, 4TH PINION	1	
5	93440-16089-00	CIRCLIP	1	
6	99009-13400-00	CIRCLIP (55X)	1	
7	353-17471-00-00	PLATE, COVER	1	
8	98580-06012-00	SCREW, PAN HEAD	2	
9	93306-20333-00	BEARING	1	
10	598-17421-00-00	AXLE, DRIVE	1	
11	353-17211-01-00	GEAR, 1ST WHEEL	1	
12	367-17221-00-00	GEAR, 2ND WHEEL	1	
13	353-17231-00-00	GEAR, 3RD WHEEL	1	
14	353-17241-00-00	GEAR, 4TH WHEEL	1	
15	90387-16126-00	COLLAR	1	
16	257-17219-00-00	SHIM	1	
17	93440-16089-00	CIRCLIP	2	
18	99009-13400-00	CIRCLIP (55X)	1	
19	52G-17968-00-10	SHIM, (1.0T)	1	
20	93306-30302-00	BEARING	1	
21	93102-25017-00	OIL SEAL	1	
22	90387-17137-00	COLLAR	1	
23	93811-13020-00	SPROCKET, DRIVE (257-17461-31)	1	U.R.
	93811-14033-00	SPROCKET, DRIVE	1	U.R. STD
	93811-15060-00	SPROCKET, DRIVE (257-17461-51)	1	U.R.
24	90179-12181-00	NUT, SPEC'L SHAPE	1	
25	90215-13019-00	WASHER, LOCK	1	

CONTINUED ON NEXT FRAME ►

TRANSMISSION

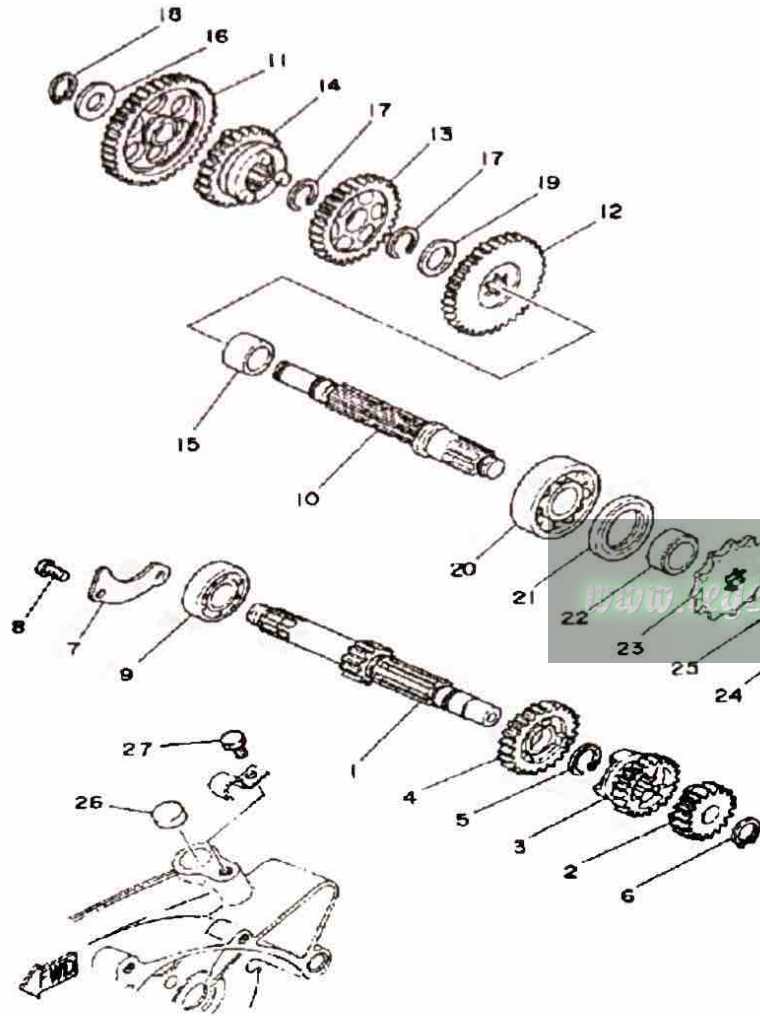

Ref. No.	Part Number	Description	Qty	Remarks
26	90338-16015-00	PLUG, BLIND (168-17481-00) ..	1	
27	97011-06010-00	BOLT	1	

SHIFT CAM - FORK

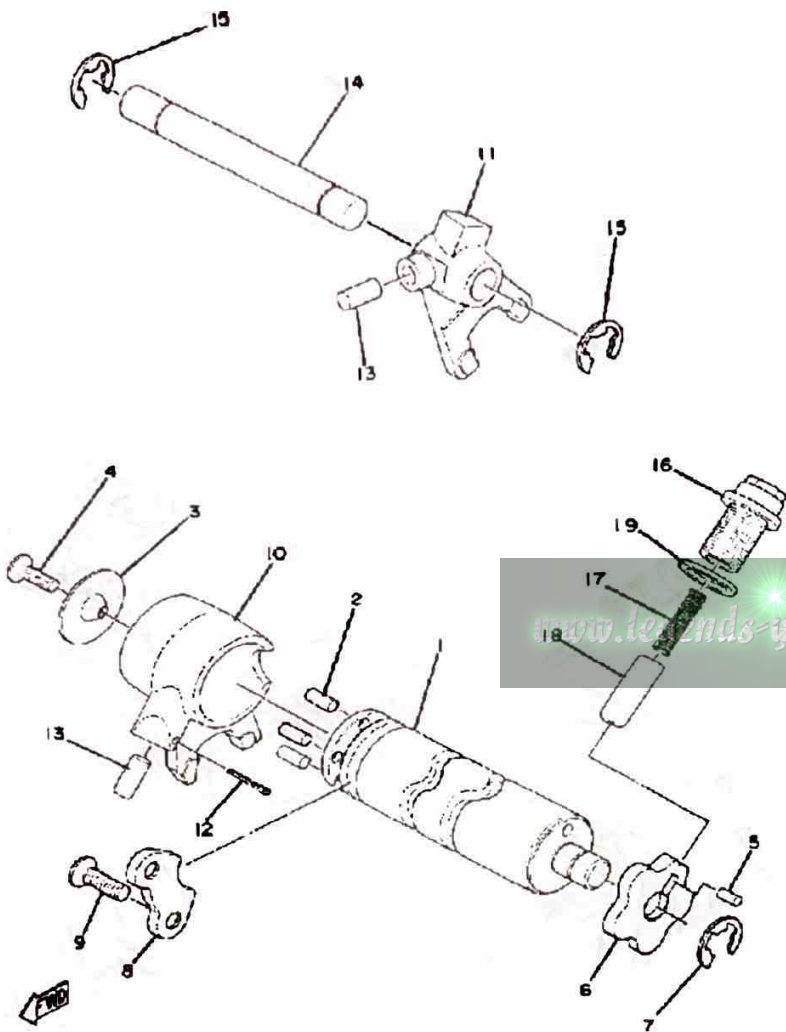

Ref. No.	Part Number	Description	Qty	Remarks
1	367-18540-01-00	SHIFT CAM ASSEMBLY	1	
2	93604-10011-00	PIN, DOWEL	4	
3	214-18561-00-00	PLATE, SIDE 1	1	
4	98701-05012-00	SCREW, FLAT HEAD	1	
5	93604-08071-00	PIN, DOWEL	1	
6	(374-18141-00-00)	PLATE, STOPPER	1	
7	93440-12026-00	CIRCLIP, OUTER	1	
8	353-18562-00-00	PLATE, STOPPER 2	1	
9	98603-06012-00	SCREW, OVAL HEAD (92701-06012)	2	
10	353-18511-01-00	FORK, SHIFT 1	1	
11	353-18512-01-00	FORK, SHIFT 2	1	
12	91401-25020-00	PIN, COTTER	1	
13	93606-14081-00	PIN, DOWEL	2	
14	214-18531-00-00	BAR, SHIFT FORK GUIDE 1	1	
15	99006-10600-00	CIRCLIP	2	
16	90109-14485-00	BOLT	1	
17	90501-09292-00	SPRING, COMPRESSION	1	
18	353-18547-00-00	STOPPER, CAM	1	
19	137-15353-00-00	GASKET, DRAIN	1	

SHIFT SHAFT - PEDAL

Ref. No.	Part Number	Description	Qty	Remarks
1	353-18101-03-00	SHIFT SHAFT ASSEMBLY	1	
2	353-18120-00-00	SHIFT LEVER ASSEMBLY	1	
3	214-18178-00-00	ROLLER, SHIFT LEVER	1	
4	90508-32054-00	SPRING, TORSION	1	
5	367-18197-00-00	SHAFT	1	
6	99006-10600-00	CIRCLIP	1	
7	90149-08094-00	SCREW	1	
8	95333-08600-00	NUT	1	
9	93102-12321-00	OIL SEAL, SD-TYPE	1	
10	90201-12575-00	WASHER, PLATE	1	
11	99006-10600-00	CIRCLIP	1	
12	367-18111-00-00	PEDAL SHIFT	1	UNI CHROME
13	132-18113-01-00	COVER, SHIFT PEDAL	1	
14	97011-06020-00	BOLT	1	
15	90340-10003-00	PLUG, STRAIGHT SCRW	1	
16	90430-10031-00	GASKET	1	

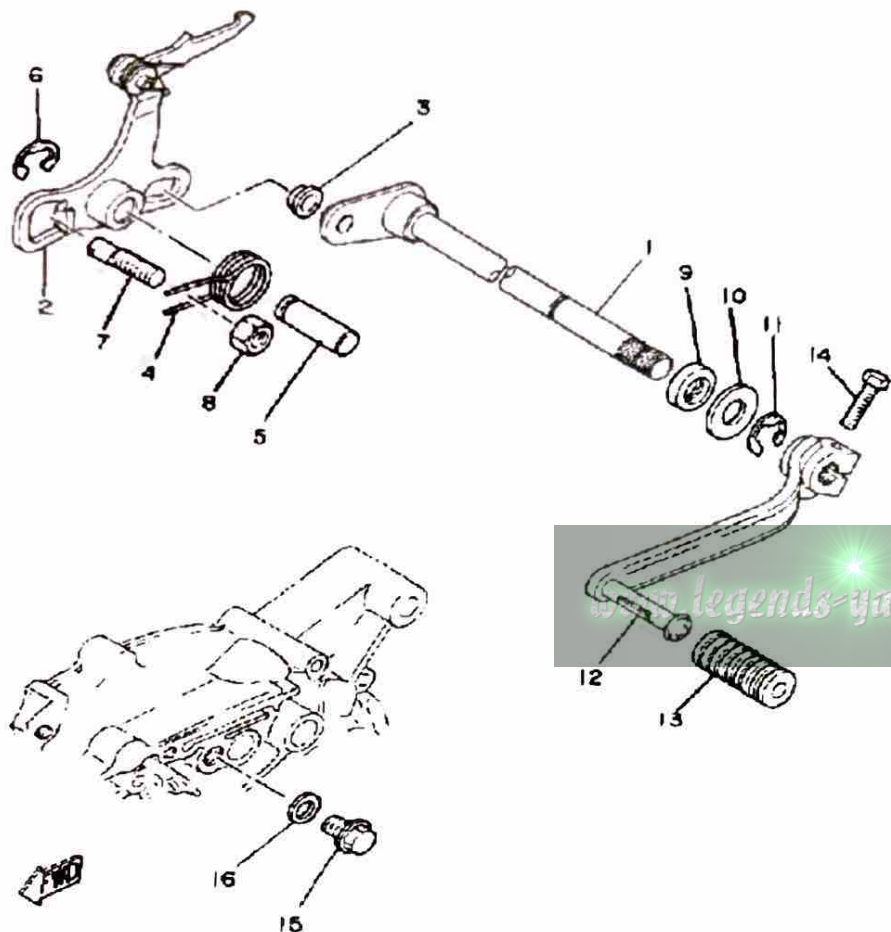

FRAME - TOOL

Ref. No.	Part Number	Description	Qty	Remarks
1	(2A3-21110-00-33)	FRAME	1	YAMAHA BLK
2	95811-08090-00	BOLT, FLANGE (95822-08090) .	1	
3	95811-08095-00	BOLT, FLANGE	1	
4	95811-08120-00	BOLT, FLANGE (95812-08120) .	1	
5	95701-08500-00	NUT, FLANGE	3	
6	92990-08100-00	WASHER, SPRING	3	
7	2U2-W2810-00-00	TOOL KIT	1	
8	21V-21376-00-00	BAND, TOOL	1	
9	353-15361-00-00	GAUGE, LEVEL	1	
10	449-85131-02-00	REFLECTOR, REAR 1	3	ALTERNATE PRTS
11	92990-05100-00	WASHER, SPRING	2	ALTERNATE PRTS
12	92990-05200-00	WASHER, PLAIN	2	ALTERNATE PRTS
13	95380-05600-00	NUT	2	ALTERNATE PRTS

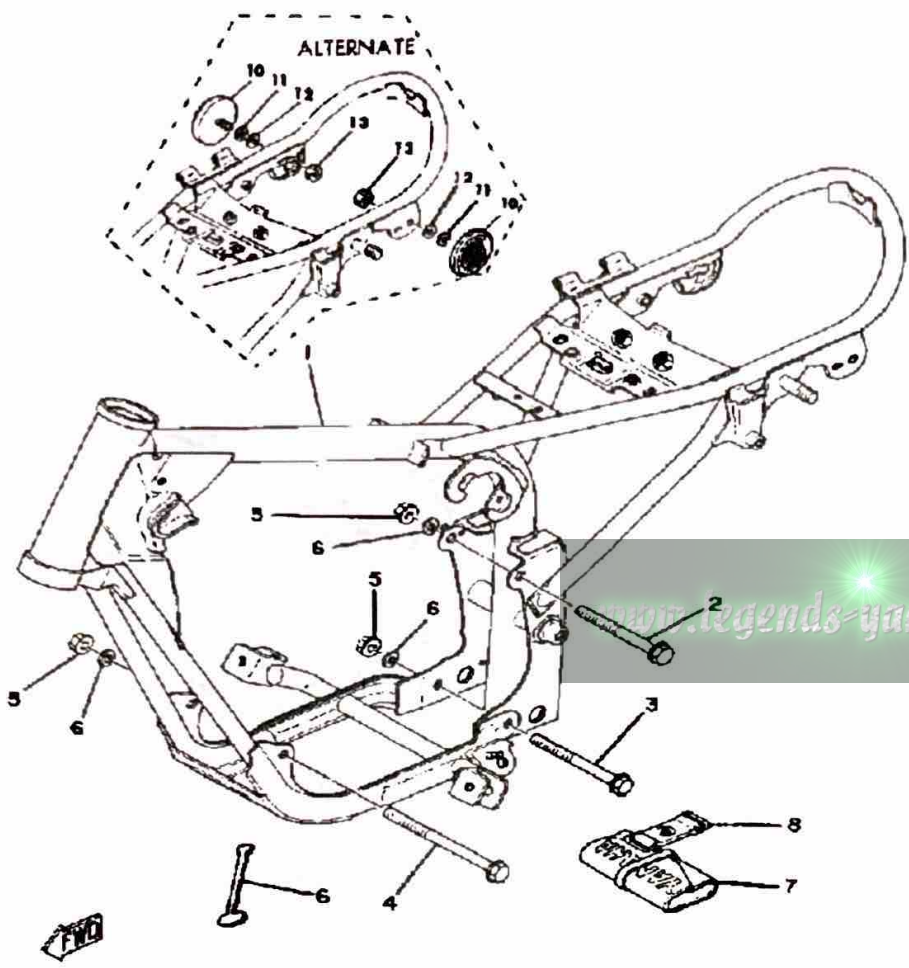

FRONT FENDER - REAR FENDER

Ref. No.	Part Number	Description	Qty	Remarks
1	288-21510-01-36	FENDER, FRONT	1	CLEAN WHITE
2	97011-06010-00	BOLT	3	
3	92901-06600-00	WASHER	3	
4	(367-21610-01-36)	FENDER, REAR	1	CLEAN WHITE
5	97301-06014-00	BOLT, HEXAGON	4	
6	92995-06100-00	WASHER, SPRING	4	
7	92901-06600-00	WASHER	4	
8	90338-07043-00	PLUG, SPEC"L SHAPE	2	
9	214-84154-60-00	GROMMET	2	
10	288-21659-00-00	LABEL, SAFETY	1	
11	449-85131-02-00	REFLECTOR, REAR 1	3	ALTERNATE PRTS
12	92990-05100-00	WASHER, SPRING	1	ALTERNATE PRTS
13	92990-05200-00	WASHER, PLAIN	1	ALTERNATE PRTS
14	95380-05600-00	NUT	1	ALTERNATE PRTS
15	(367-85132-00-00)	BRACKET, REFLECT 1	1	ALTERNATE PRTS
16	97013-06012-00	BOLT	1	ALTERNATE PRTS
17	95380-06600-00	NUT	1	ALTERNATE PRTS
18	92995-06100-00	WASHER, SPRING	1	ALTERNATE PRTS
19	92990-06200-00	WASHER, PLAIN	1	ALTERNATE PRTS

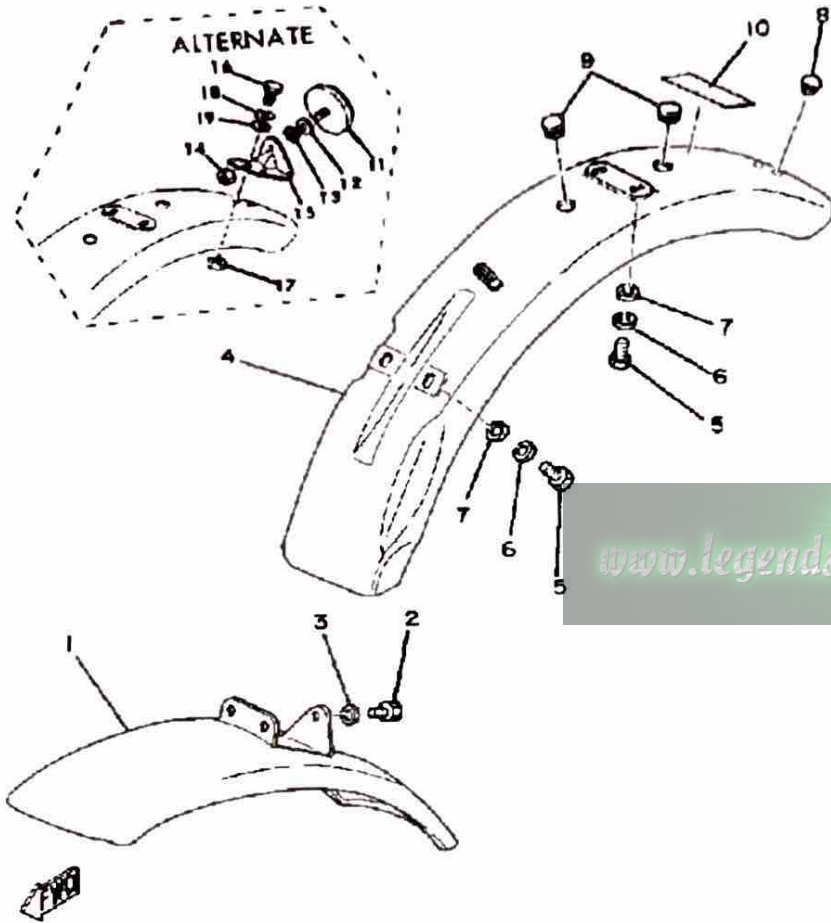

OIL TANK

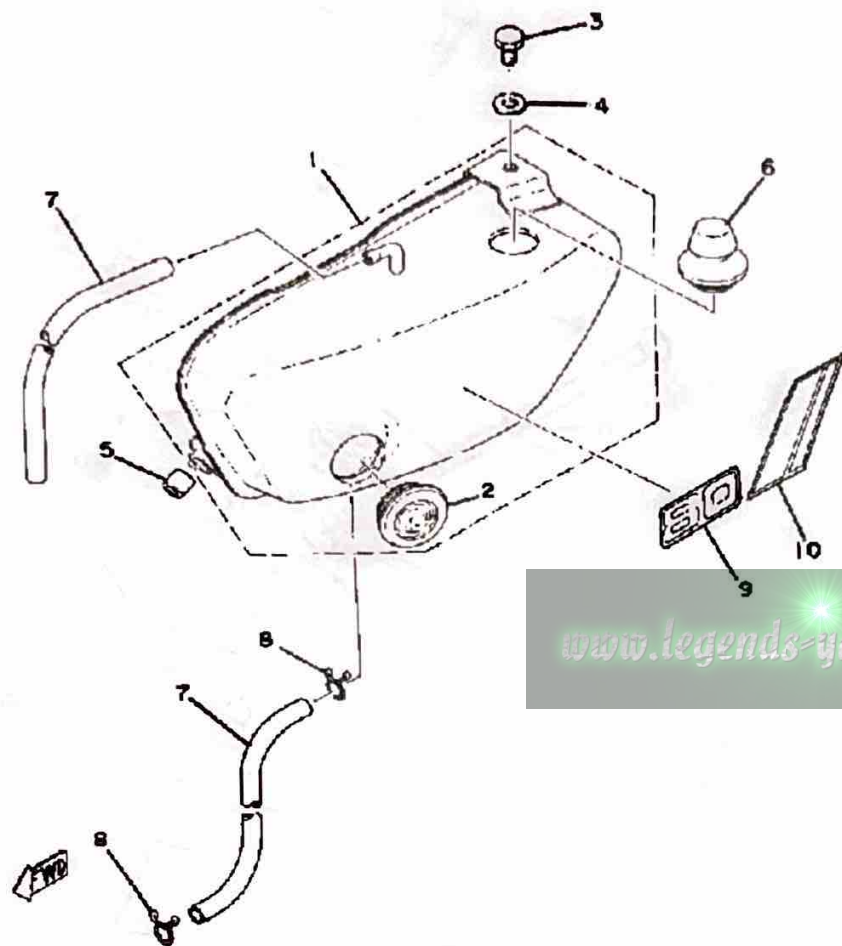

Ref. No.	Part Number	Description	Qty	Remarks
1	(367-21705-10-36)	OIL TANK ASSEMBLY	1	CLEAN WHITE
2	214-21761-00-00	. GAUGE, LEVEL	1	
3	97013-06012-00	BOLT	1	
4	92901-06600-00	WASHER	1	
5	353-21778-00-00	DAMPER, LOCATING 1	1	
6	2A3-21771-00-00	BODY, CAP	1	
7	90445-09226-00	HOSE	1	
	90445-09226-00	HOSE	2	
8	90467-08003-00	CLIP	2	
9	3J8-21781-10-00	EMBLEM 1	1	
10	(367-21782-00-00)	EMBLEM 2	1	

www.legends-yamaha-enduros.com

REAR ARM - SUSPENSION

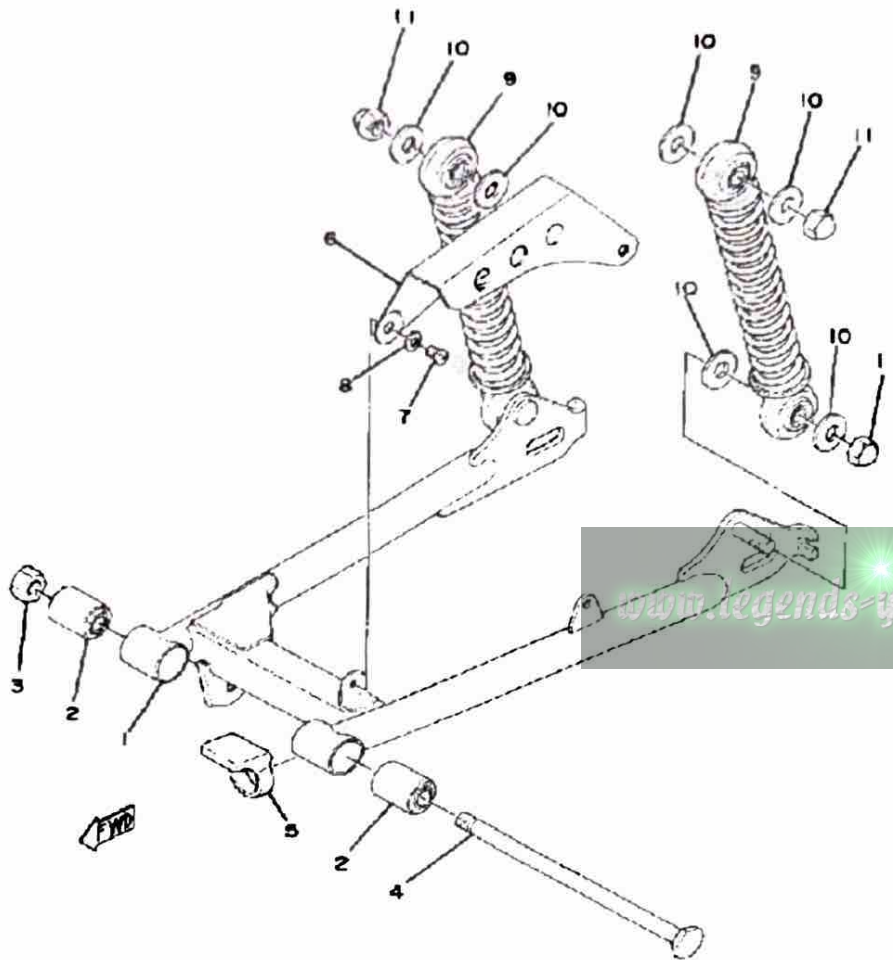

Ref. No.	Part Number	Description	Qty	Remarks
1	367-22110-00-33	NO LONGER AVAILABLE	1	YAMAHA BLK
2	102-22123-00-00	BUSH 1	2	
3	95303-10600-00	NUT (95301-10600)	1	
4	288-22141-00-00	SHAFT, PIVOT	1	
5	183-22151-00-00	SEAL, GUARD	1	
6	288-22311-00-33	CASE, CHAIN	1	YAMAHA BLK
7	98580-05010-00	SCREW, PAN HEAD	2	
8	92990-05100-00	WASHER, SPRING	2	
9	367-22210-21-00	SHK/ABS ASSEMBLY, REAR	2	
10	90201-10437-00	WASHER, PLATE	8	
11	90176-10013-00	NUT, CROWN	4	

STEERING

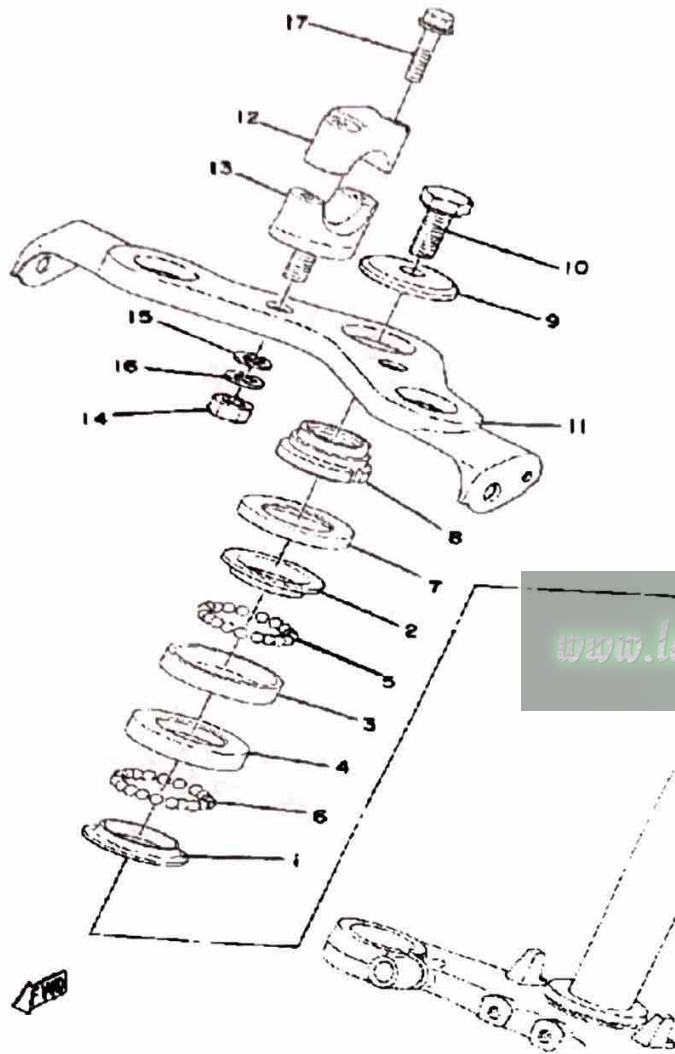

Ref. No.	Part Number	Description	Qty	Remarks
1	156-23411-00-00	RACE, BALL 1	1	
2	22F-23411-01-00	RACE, BALL 1	1	
3	22F-23412-01-00	RACE, BALL 2	1	
4	156-23412-00-00	RACE, BALL 2	1	
5	93503-16010-00	BALL	22	
6	93501-04011-00	BALL	19	
7	122-23416-00-00	COVER, BALL RACE 2	1	
8	90179-25051-00	NUT	1	
9	90209-10021-00	WASHER, SPEC'L SHAP	1	
10	90105-10006-00	BOLT, WASHER BASED	1	
11	185-23435-00-98	CROWN, HANDLE	1	
12	462-23441-00-00	HOLDER, HANDLE UPR (122-23441-00-00)	2	
13	462-23442-00-98	HOLDER, HANDLE LWR (122-23442-02-00)	2	
14	95303-10600-00	NUT (95301-10600)	2	
15	92990-10600-00	WASHER, PLATE	2	
16	92990-10100-00	WASHER, SPRING	2	
17	90119-06017-00	BOLT, WITH WASHER	4	

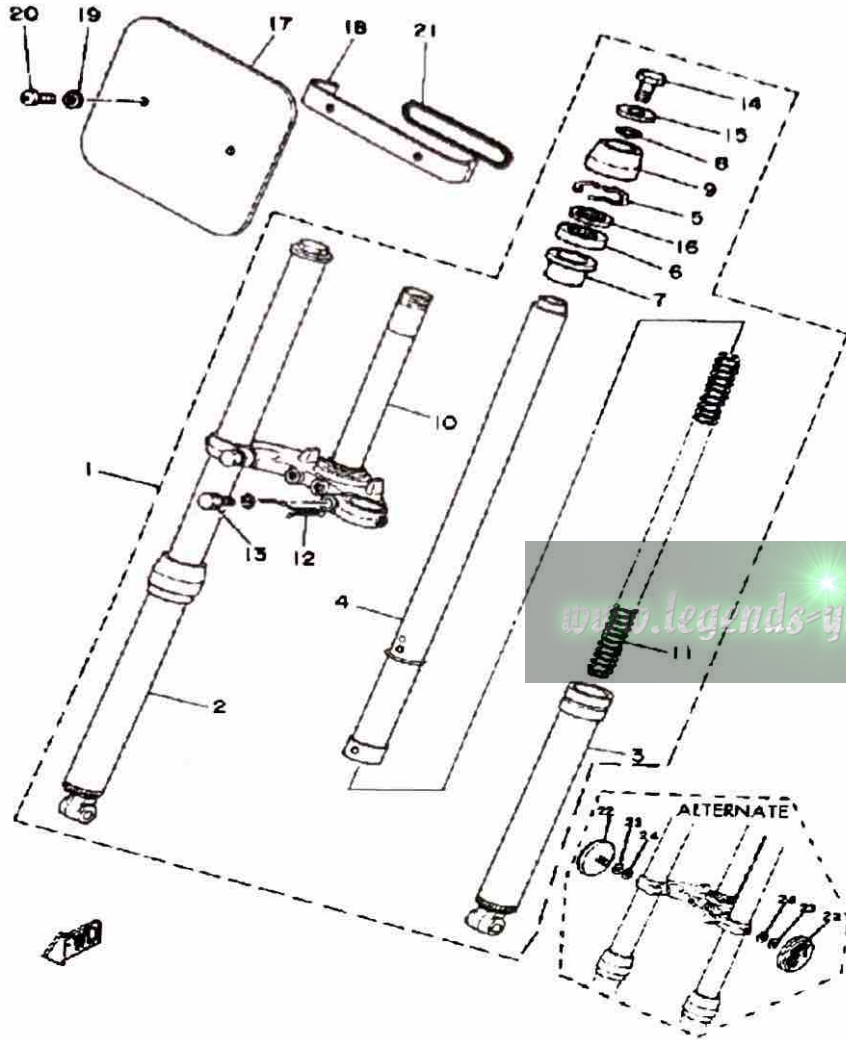

FRONT FORK

Ref. No.	Part Number	Description	Qty	Remarks
1	(367-23101-62-00)	FRONT FORK ASSEMBLY	1	
2	(367-23136-62-35)	TUBE, OUTER 2	1	SILVER
3	(367-23126-62-35)	TUBE, OUTER 1	1	SILVER
4	(367-23134-62-00)	TUBE, INNER 2	2	
5	1T8-23156-00-00	. CLIP, OIL SEAL	2	
6	3VR-23145-00-00	. OIL SEAL	2	
7	367-23125-60-00	. METAL, SLIDE 1	2	
8	307-23114-00-00	. O-RING	2	
9	367-23144-60-00	. SEAL, DUST	2	
10	367-23340-60-33	. UNDER BRACKET	1	YAMAHA BLK
11	(367-23141-62-00)	SPRING, FRONT FORK	2	
12	(2A3-23319-00-00)	HOLDER, CABLE 2	1	
13	5J0-23346-00-00	. BOLT 1	2	
14	395-23111-00-00	. BOLT, CAP	2	
15	207-23112-00-00	. WASHER, CAP	2	
16	(367-23146-60-00)	WASHER, OIL SEAL	2	
17	288-23485-00-00	PLATE, NUMBER	1	
18	288-23486-00-00	STAY, PLATE	1	
19	92901-06600-00	WASHER	2	
20	98580-06010-00	SCREW, PAN HEAD (92503-06010)	2	
21	288-23489-00-00	BAND	1	
22	355-85111-01-00	REFLECTOR, FRONT 1	2	ALTERNATE PRTS
23	92990-05100-00	WASHER, SPRING	2	ALTERNATE PRTS
24	92990-05200-00	WASHER, PLAIN	2	ALTERNATE PRTS

FUEL TANK

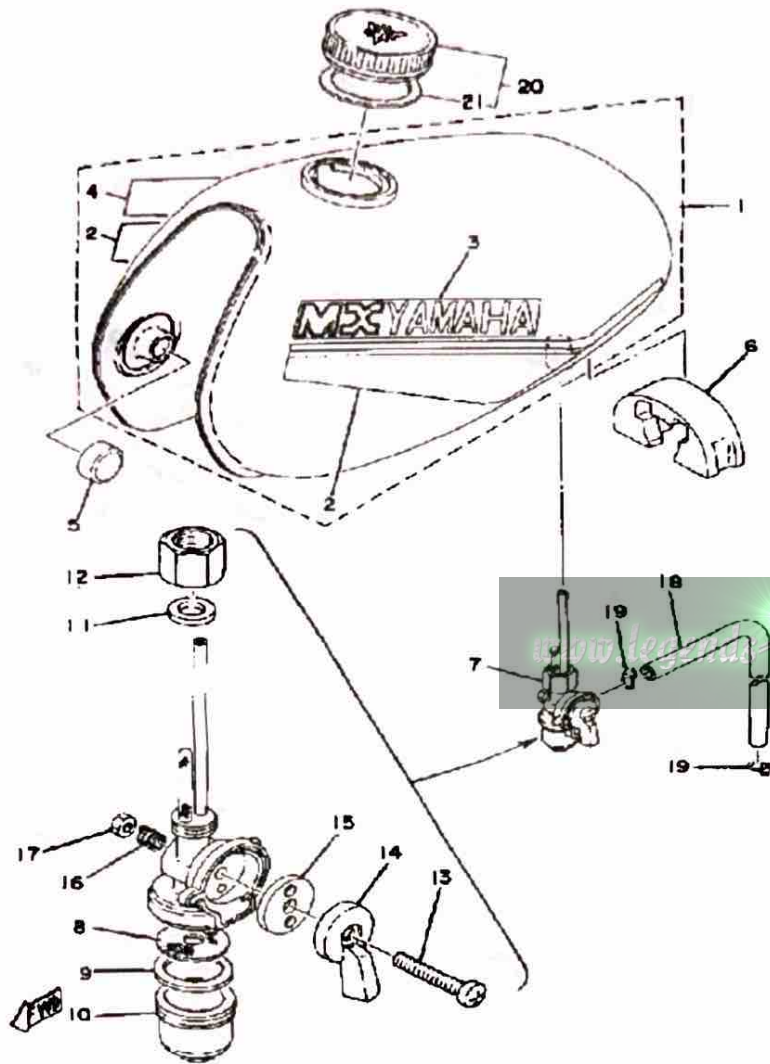

Ref. No.	Part Number	Description	Qty	Remarks
1	367-24110-Y0-W4	FUEL TANK	1	CLEAN WHITE
2	367-24240-50-00	. GRAPHIC SET	1	
3	367-24246-40-00	. GRAPHIC, FUEL TNK 3	1	
4	367-24247-40-00	. GRAPHIC, FUEL TNK 4	1	
5	122-24181-00-00	DAMPER, LOCATING 1	2	
6	353-24182-00-00	DAMPER, LOCATING 2	1	
7	367-24500-04-00	FUEL COCK ASSEMBLY 1 (5U7-24500-00)	1	
8	355-24515-00-00	. NET, FILTER 2	1	
9	102-24522-01-00	. GASKET	1	
10	122-24521-00-00	. CUP, FILTER	1	
11	122-24532-00-00	. GASKET	1	
12	603-24531-01-00	. NUT	1	
13	98501-05030-00	. SCREW, PAN HEAD	1	
14	(355-24524-01-00)	LEVER, COCK	1	
15	355-24523-00-00	. VALVE	1	
16	(355-24518-00-00)	WASHER, WAVE	1	
17	95380-05600-00	. NUT	1	
18	90445-09066-00	HOSE	1	
19	90467-08003-00	CLIP	2	
20	122-24610-01-00	CAP ASSEMBLY	1	
21	122-24612-01-00	. GASKET, CAP	1	

SEAT

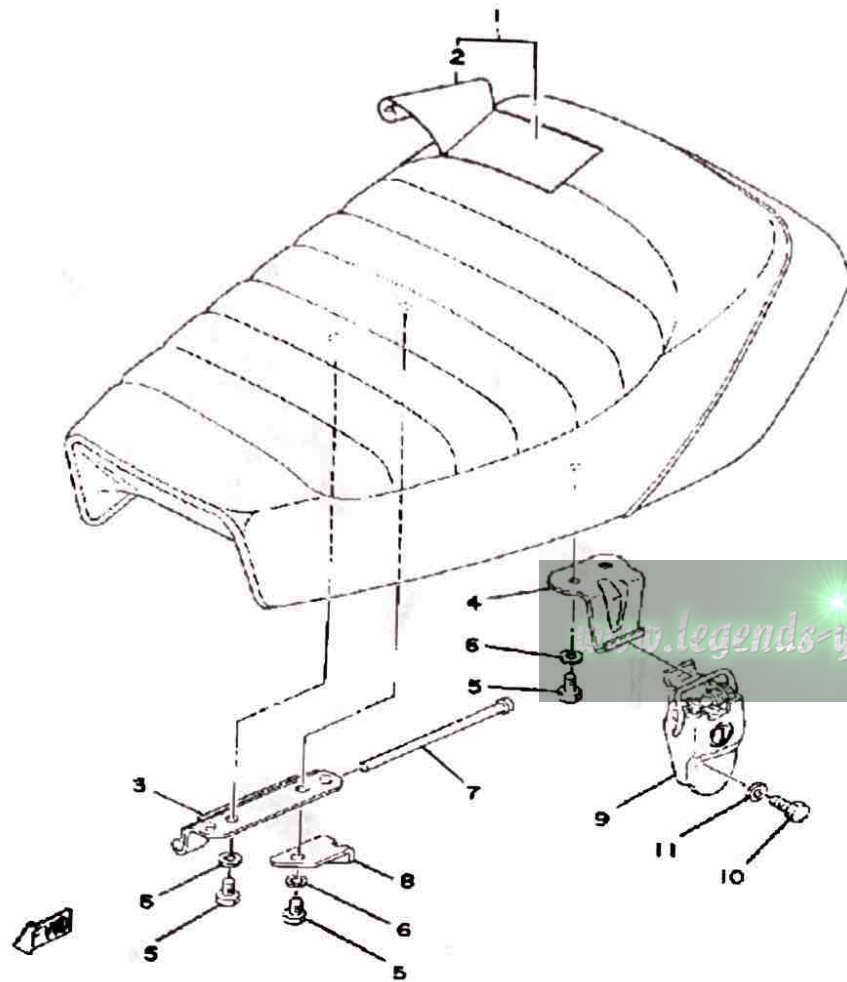

Ref. No.	Part Number	Description	Qty	Remarks
1	2A3-W2473-00-00	SEMI-DBL-SEAT ASSEMBLY ..	1	
2	367-24771-10-00	. COVER, SM-DBL SEAT	1	
3	353-24726-00-00	HINGE, SEAT	1	
4	278-24728-00-00	BRACKET, SEAT	1	
5	97013-06012-00	BOLT	4	
6	92995-06100-00	WASHER, SPRING	4	
7	91701-05105-00	PIN, CLEVIS (3M7)	1	
8	374-24768-00-00	STOPPER	1	
9	367-24760-00-00	SEAT LEVER ASSEMBLY	1	
10	97011-06025-00	BOLT (97001-06025)	1	
11	92901-06600-00	WASHER	1	

FRONT WHEEL

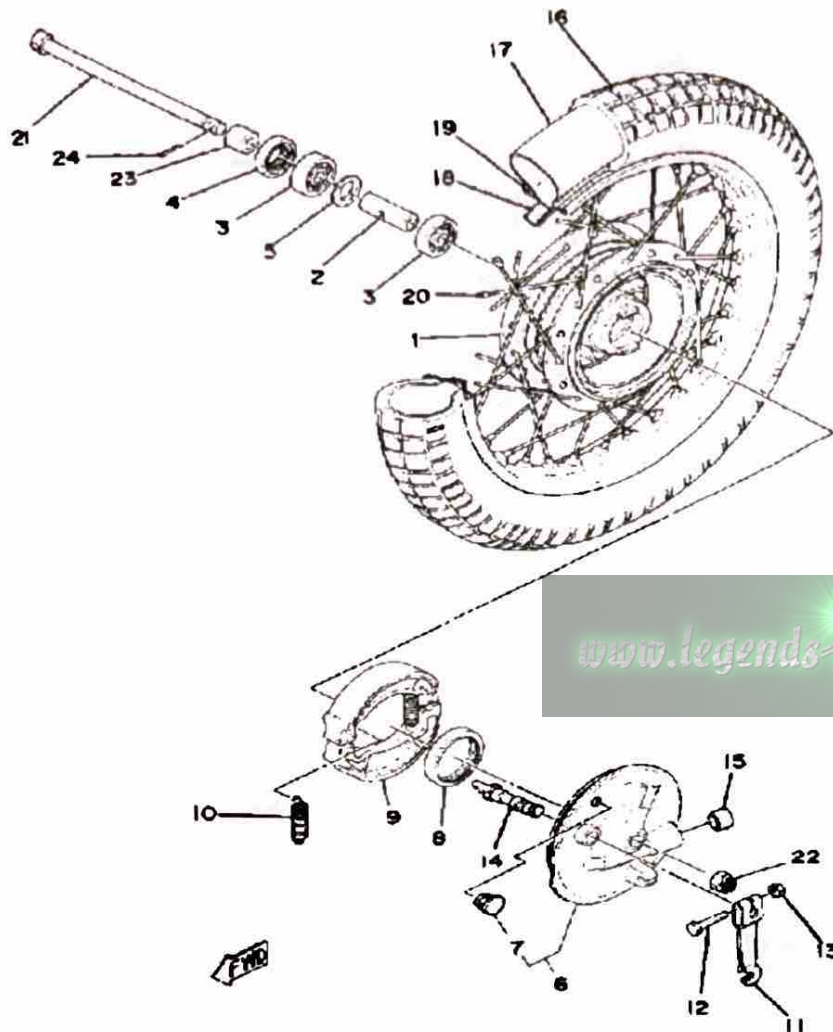

Ref. No.	Part Number	Description	Qty	Remarks
1	(367-25111-00-Y8)	HUB, FRONT	1	SILVER DUST
2	90560-10303-00	SPACER, BEARING	1	
3	93306-30003-00	BEARING (B6300Z)	2	
4	93102-20009-00	OIL SEAL	1	
5	2E9-25116-00-00	FLANGE, SPACER 2	1	
6	1K8-25016-00-Y8	BRAKE SHOE PLT ASSEMBLY	1	SILVER DUST
7	90480-10068-00	. GROMMET	1	
8	93105-47007-00	OIL SEAL	1	
9	296-W2536-00-00	BRAKESHOE SET-2PCS	2	
10	90506-16150-00	SPRING, TENSION (102-25333-00)	2	
11	538-25155-00-00	LEVER, CAMSHAFT 1	1	
12	90101-06278-00	BOLT	1	
13	95380-06600-00	NUT	1	
14	3Y6-25351-00-00	CAMSHAFT	1	
15	90338-18014-00	PLUG	1	
16	94125-15478-00	250-15 IRC TRIALS	1	
17	94225-15103-00	TUBE 250X 5	1	
18	94313-15154-00	BAND, RIM	1	
19	94414-15058-00	RIM 1.40X 5	1	
20	288-25104-01-00	SPOKE SET, FRONT	1	
21	99999-02188-00	AXLE, WHEEL (353-25181-03-00)	1	
22	90171-10004-00	NUT, CASTLE	1	
23	90387-10077-00	COLLAR	1	
24	91490-20020-00	PIN, COTTER	1	

REAR WHEEL

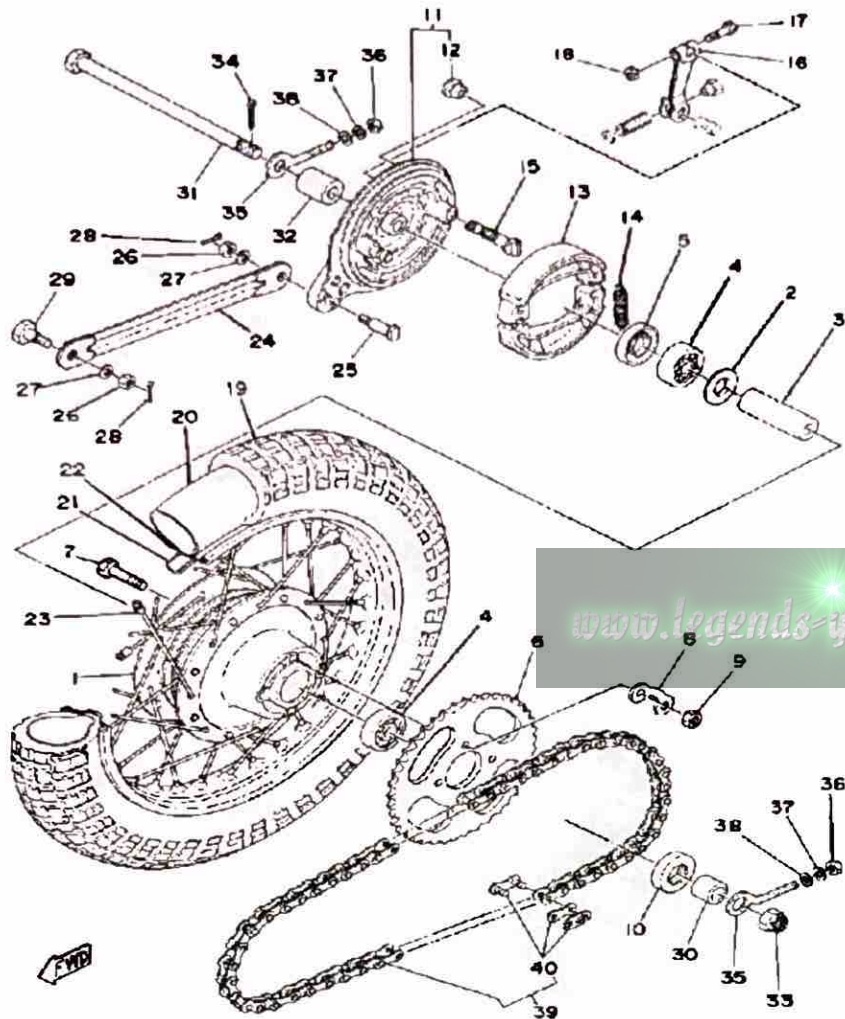

Ref. No.	Part Number	Description	Qty	Remarks
1	(288-25311-01-Y8)	HUB, REAR	1	SILVER DUST
2	109-25315-00-00	FLANGE, SPACER	1	
3	90560-12170-00	SPACER	1	
4	93306-30101-00	BEARING (B6301)	2	
5	93106-20033-00	OIL SEAL (3TU)	1	
6	5J1-25441-20-00	SPROCKET, DRVN 41T (288-25441-10-33)	1	
7	90109-08319-00	BOLT	4	
8	2A3-25412-00-00	WASHER	2	
9	90170-08158-00	NUT	4	
10	93104-21016-00	OIL SEAL, SO-TYPE	1	
11	355-25026-00-Y8	BRAKE SHOE PLT ASSEMBLY	1	SILVER DUST
12	90480-10068-00	GROMMET	1	
13	296-W2536-00-00	BRAKESHOE SET-2PCS	2	
14	90506-16150-00	SPRING, TENSION (102-25333-00)	2	
15	3Y6-25351-00-00	CAMSHAFT	1	
16	538-25355-00-00	LEVER, CAMSHAFT	1	
17	90101-06278-00	BOLT	1	
18	95380-06600-00	NUT	1	
19	94127-14477-00	275-14 IRC TRIALS	1	
20	94227-14196-00	TUBE	1	
21	94327-14076-00	BAND, RIM (2.50-14) (94325-14099-00)	1	
22	94414-14077-00	RIM 1.40X 4	1	
23	367-25304-00-00	SPOKE SET, REAR	1	
24	353-25371-00-00	BAR, TENSION	1	
25	90109-08183-00	BOLT	1	
26	95303-08700-00	NUT	2	
27	92990-08100-00	WASHER, SPRING	2	

CONTINUED ON NEXT FRAME ►

REAR WHEEL

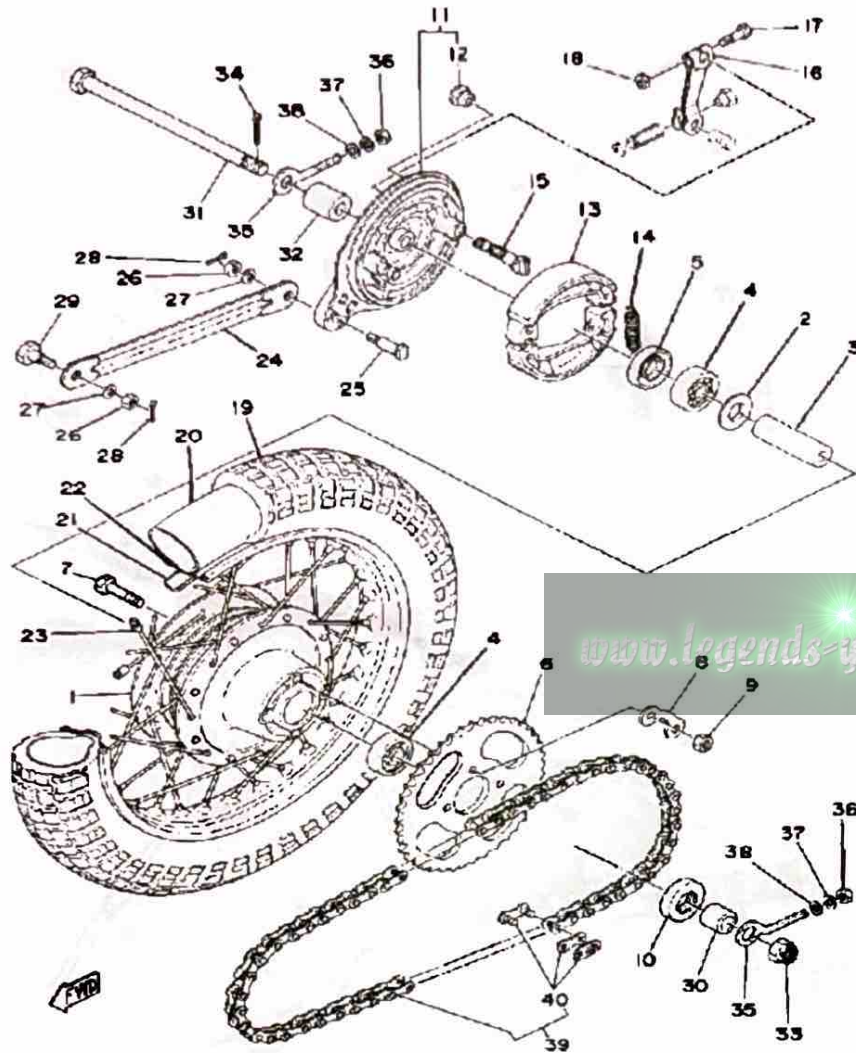

Ref. No.	Part Number	Description	Qty	Remarks
28	91490-20020-00	PIN, COTTER	2	
29	90109-08368-00	BOLT	1	
30	90387-120F9-00	COLLAR	1	
31	367-25381-00-00	AXLE, WHEEL	1	
32	90387-12412-00	COLLAR	1	
33	90171-12005-00	NUT, CASTLE	1	
34	91401-30030-00	PIN, COTTER	1	
35	102-25389-00-00	PULLER, CHAIN 2	2	
36	95380-06600-00	NUT	2	
37	92995-06100-00	WASHER, SPRING	2	
38	92901-06600-00	WASHER	2	
39	94580-52096-00	420M-96RD	1	
40	94680-52001-00	. JOINT, CHAIN (DID 420M)	1	

HANDLEBAR - CABLE

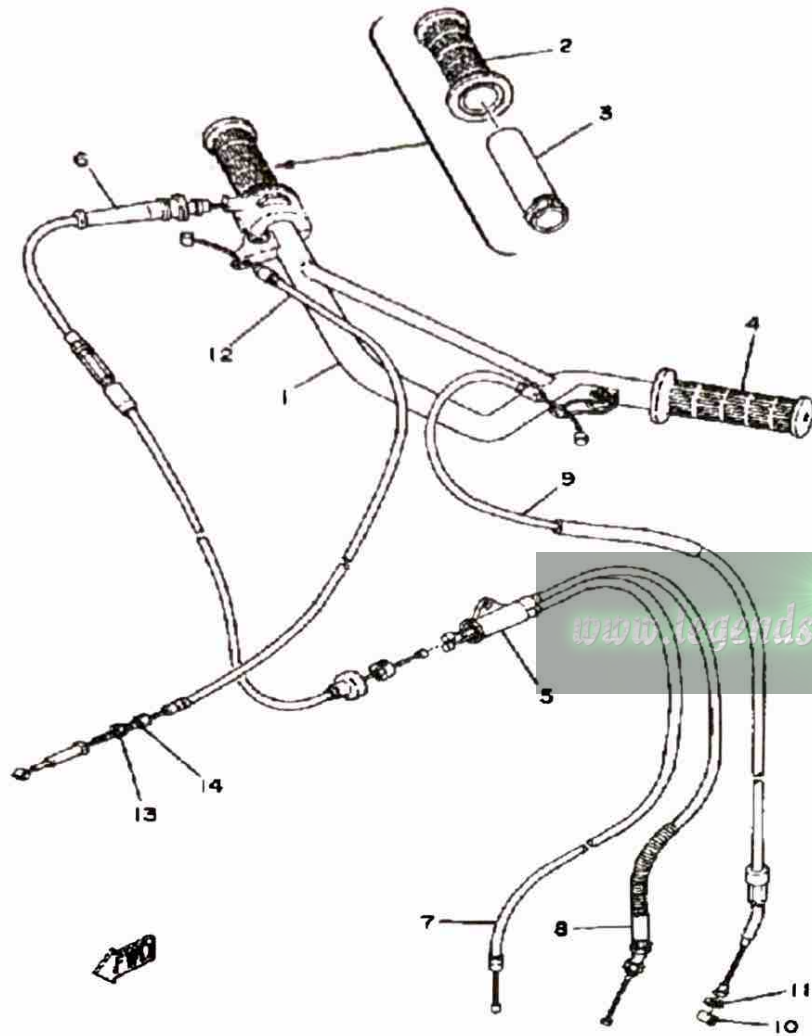

Ref. No.	Part Number	Description	Qty	Remarks
1	367-26111-03-00	HANDLEBAR	1	
2	462-26242-00-00	GRIP (R.H.)	1	
3	434-26243-12-00	TUBE, THROTTLE GUIDE	1	
4	462-26241-00-00	GRIP (L.H.)	1	
5	4U1-26261-00-00	CONNECTOR, CABLE	1	
6	367-26311-02-00	CABLE, THROTTLE 1	1	
7	367-26312-01-00	CABLE, THROTTLE 2	1	
8	367-26321-02-00	CABLE, PUMP	1	
9	367-26335-02-00	CABLE, CLUTCH	1	
10	164-26363-00-00	END, CABLE	1	
11	92901-06600-00	WASHER	1	
12	367-26341-01-00	CABLE, BRAKE	1	
13	90179-06143-00	NUT, SPEC'L SHAPE	1	
14	90123-06011-00	BOLT	1	

STAND - FOOTREST

Ref. No.	Part Number	Description	Qty	Remarks
1	2F4-27211-00-R4	PEDAL, BRAKE	1	BLACK
2	90508-32056-00	SPRING, TORSION	1	
3	93430-12008-00	CIRCLIP	1	
4	2A3-27212-00-00	SHAFT, BRAKE PEDAL	1	
5	288-27231-00-00	ROD, BRAKE	1	
6	92901-06600-00	WASHER	2	
7	91490-20020-00	PIN, COTTER	1	
8	90501-10245-00	SPRING, COMPRESSION	1	
9	90249-12008-00	PIN	1	
10	90179-06176-00	NUT, WING (90175-06013)	1	
11	367-27311-02-R4	STAND, SIDE	1	BLACK
12	90109-08031-00	BOLT	1	
13	90506-29052-00	SPRING, TENSION	1	
14	90185-08055-00	NUT, SELF-LOCKING	1	
15	214-27421-00-00	FOOTREST 2	2	
16	214-27413-00-00	COVER, FOOTREST	2	
17	91701-08038-00	PIN, CLEVIS	2	
18	91490-20020-00	PIN, COTTER	2	

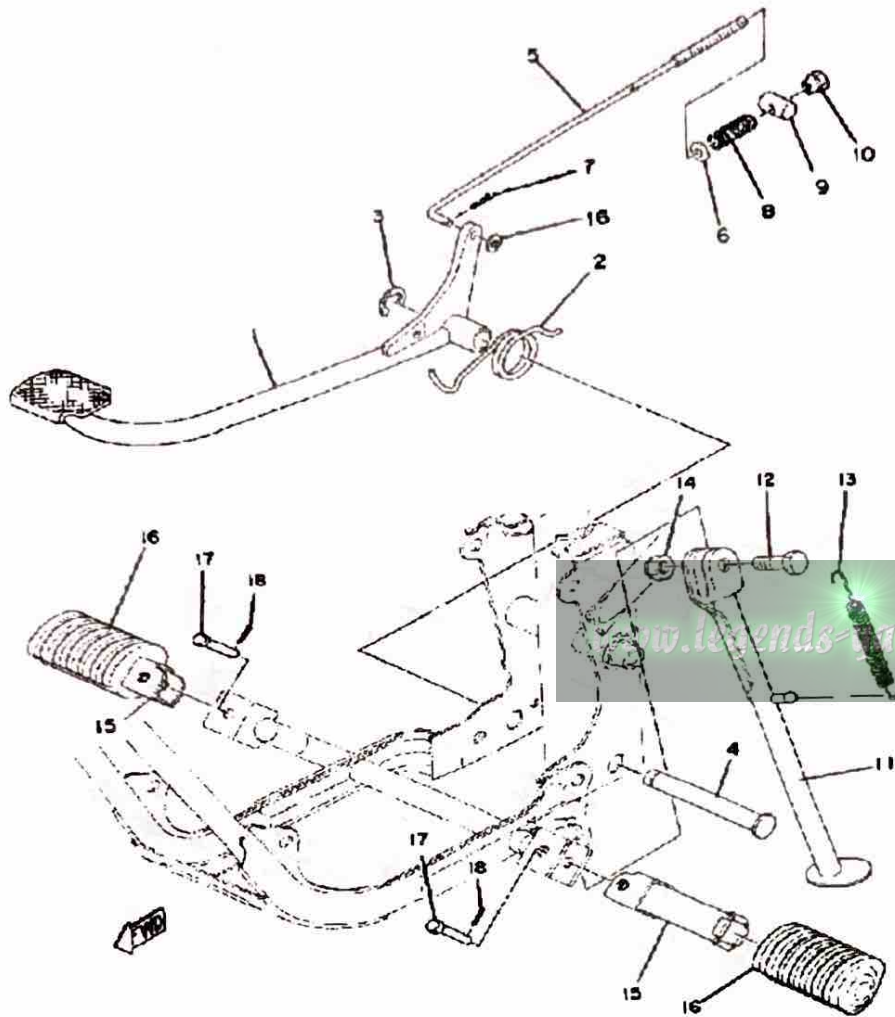

ELECTRICAL 1

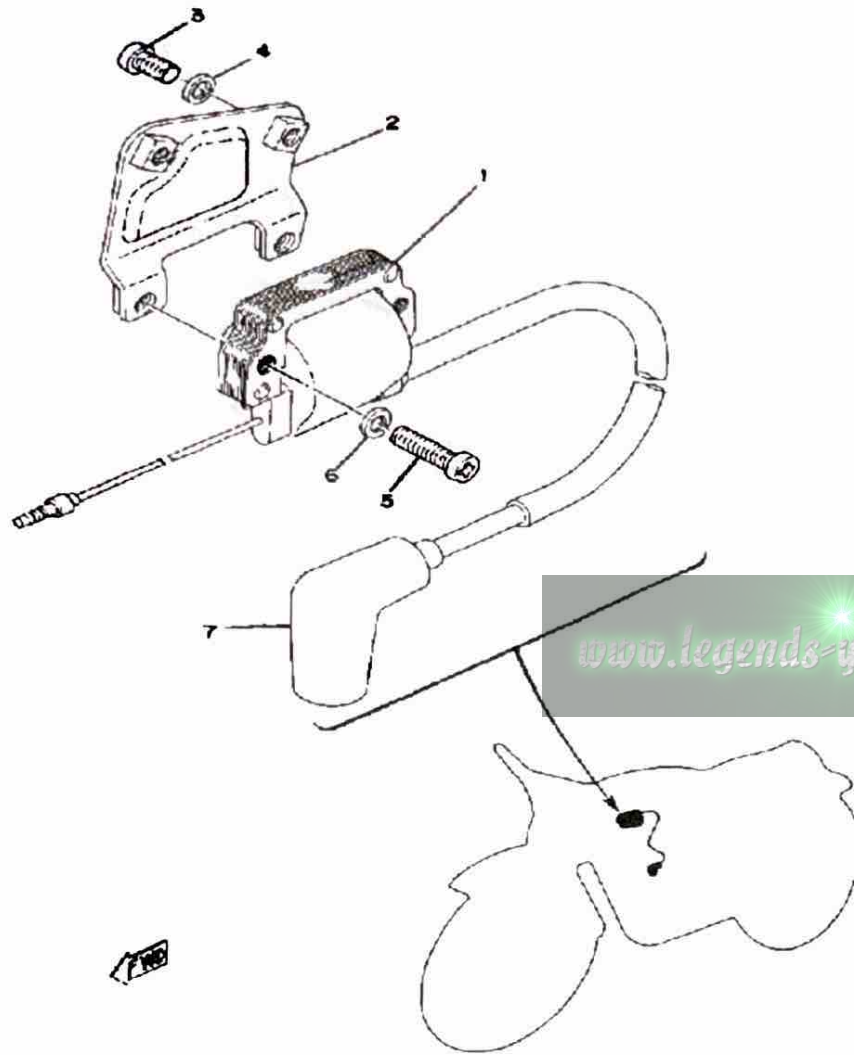

Ref. No.	Part Number	Description	Qty	Remarks
1	206-82310-41-00	IGNITION COIL ASSEMBLY ...	1	
2	375-82316-01-00	BRACKET, IGN COIL	1	
3	98580-06012-00	SCREW, PAN HEAD	2	
4	92995-06100-00	WASHER, SPRING	2	
5	98511-06025-00	SCREW PAN HEAD (92501-06025)	2	
6	92995-06100-00	WASHER, SPRING	1	
	92995-06100-00	WASHER, SPRING	2	
7	56J-82370-00-00	PLUG CAP ASSEMBLY	1	
	808-82370-10-00	PLUG CAP ASSEMBLY	1	ALTERNATE PRTS

HANDLE SWITCH - LEVER

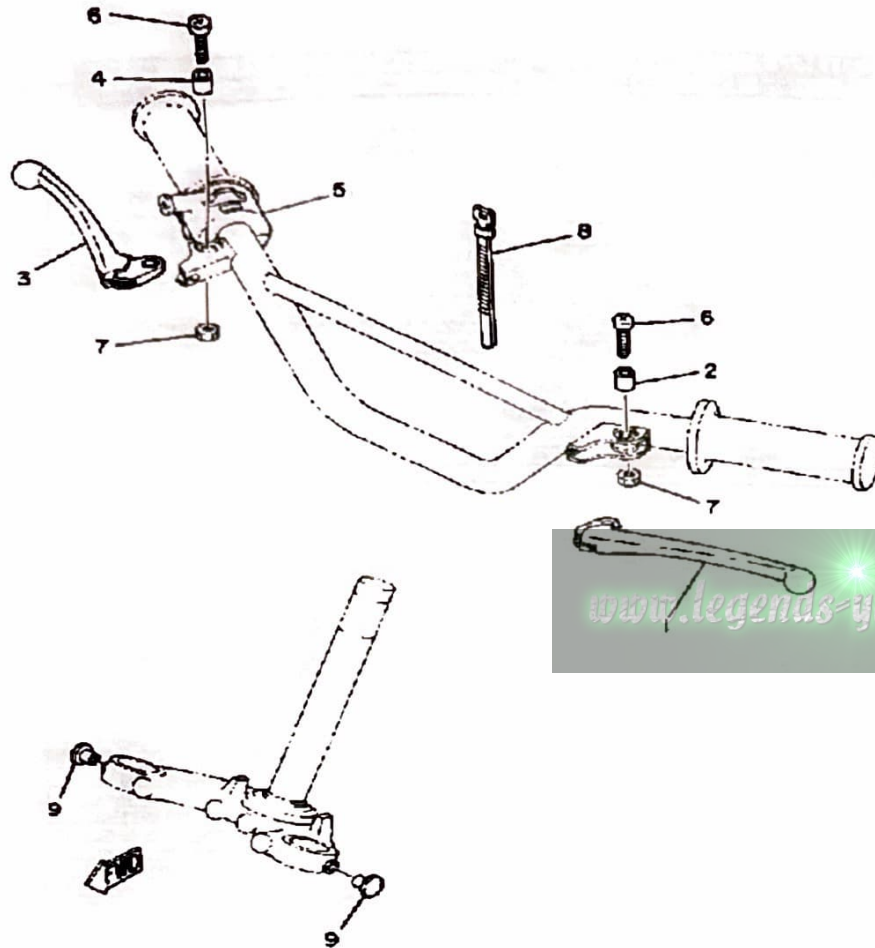

Ref. No.	Part Number	Description	Qty	Remarks
1	137-83912-02-38	LEVER L	1	CLEAR BUFFING
2	90387-05383-00	COLLAR	1	
3	2N3-83922-00-00	LEVER R	1	CLEAR BUFFING
4	90387-05383-00	COLLAR	1	
5	462-83976-01-00	SWITCH, HANDLE 1	1	
6	98501-05018-00	SCREW, PAN HEAD	2	
7	95380-05600-00	NUT	2	
8	437-83936-01-00	BAND, SWITCH CORD	1	
9	(90338-04010-00)	PLUG, SPEC"L SHAPE	2	



MX80H 1981 SERVICE DATA

MODEL - IBM I.D. NUMBER	MX80H 367
Initial Engine Number / Frame Number	367 650101 / 367-650101
Basic Color(s)	Clean White
Fuel Type / Fuel Tank Capacity / Reserve Capacity	Regular / 4.8 Lit. (1.3 Gal.) / 0.5 Lit. (0.1 Gal.)
Dry Vehicle Weight	59 kg (130 lbs.)
ENGINE TYPE	2-Stroke, Air-Cooled, Reed Valve
Bore/Stroke/Number Cylinders/Displacement (cc)	47mm / 42mm / 1 / 72cc
Compression Ratio/Compression Pressure Min~Max	6.8:1 / NA
Piston Skirt Clearance New / Max	0.035 ~ 0.040mm / 0.1mm
Ring End Gap Top / 2nd / 3rd	0.15 ~ 0.35mm / 0.15 ~ 0.35mm / Ø
Valve Clearance (Cold) Intake / Exhaust	Ø
Oil Pressure Hot / rpm	Ø
Oiling System	Autolube
Capacity: Dry	0.7 Lit. (0.74 Qt.)
Oil and Filter Change	Ø
Oil Change	Ø
Lubricant: Temp. Above 5°C (40°F)	Yamalube 2 ⁺ or Equivalent
Temp. Below 15°C (60°F)	Yamalube 2 ⁺ or Equivalent
AUTOLUBE - Min Stroke / Color Code	0.20 ~ 0.25mm / Yellow
Minimum Output @ 200 Cycles	0.50cc ~ 0.62cc
Maximum Output @ 200 Cycles	3.64cc ~ 4.27cc
CARBURETOR - Mfr. / Type / I.D. Number	Teikei / Y16P-3 / 367-81
Main Jet / Pilot Jet	94 / 34
Needle Jet / Jet Needle-Clip Position	2.080 / 049.2
Slide Cutaway or Throttle Valve	1.0
Float Level / Fuel Level	23.0mm ± 2.5mm / NA
Idle rpm	1300 rpm
Max CO* / Max HC* / Set CO	Ø
SUSPENSION	
Front Forks: Oil Type / Level / Qty	10, 20, or 30 Wt. Fork Oil* / Ø / 112cc
Gas Pressure	Ø
Spring Length Std	386mm
Monoshock: Oil Type / Qty	Ø
Gas Pressure	Ø
Minimum Brake Lining Thickness	Front: 2.0mm Rear: 2.0mm
Tire Size (Nominal Pressure)	F-25015 (1.5 kg/cm ² /21 psi) R-2.75-14 (2.0 kg/cm ² /28 psi)
TRANSMISSION - Oil Type/Qty Chg/Qty Reassemble	SAE 10W30 SE / 550cc / 600cc
Primary Drive Type / Teeth / Ratio	Helical Gear / 68:19 / 3.578
Secondary Drive Type / Teeth / Chain	Chain / 41-14 / DID420-92L
Clutch Friction Plate Thickness Std ~ Min	3.5 ~ 3.2mm
Clutch Spring Length Std ~ Min	31.5 ~ 30.5mm
Middle Gear Case Capacity	Ø
Final Gear Case Capacity	Ø
Gear Case Lubricant: Temp. Above 5°C (40°F)	Ø
Temp. Below 15°C (60°F)	Ø
All Weather Conditions	Ø

SERVICE COPY	SER MGR	MECH	MECH	MECH	BINDER
OFFICE COPY	GEN MGR	SALES	PARTS	BINDER	PAGE 1 OF 2

CHARGING SYSTEM	Flywheel Magneto / Single Phase / Half Wave
Battery: Model / Specific Gravity / Charge Rate	Ø
Maximum Output	8V4A @ 8000 rpm
TROUBLESHOOTING	
Field Coil Color Code / Ω	Ø
Charge Coil Color Code / Ω	Ø
IGNITION SYSTEM	Flywheel Magneto - External Rotor
Ignition Timing	1.8mm BTDC
Spark Plug Type	NGK B7HS
Spark Plug Gap / Torque / Cap Ω	0.5 ~ 0.6mm / 2.0 m·kg / 5K Ω ± 10%
Point Gap / Condenser Capacitance	0.3 ~ 0.4mm / 0.30 μF ± 10%
TROUBLESHOOTING	
Ignition Coil Test Gap / Primary Ω / Secondary Ω	6mm / 1.02 Ω ± 10% / 6.0K Ω ± 20%
Pulser Coil or Pickup Coil Color Code / Ω	Ø
Source Coil Color Code / Ω	Blk ~ Gnd / 1.34 Ω ± 10%
LIGHTING SYSTEM	
Headlight / Taillight / Signal Rating	Ø
TROUBLESHOOTING	
Lighting Coil Color Code / Ω	Ø
TORQUE VALUES	
Front Axle Nut	10 x 1.25: 4.0 m·kg
Front Axle Holder Nut	Ø
Rear Axle Nut	12 x 1.25: 6.0 m·kg
Rear Axle Pinch Bolt	Ø
Clutch Nut	12 x 1.0: 4.5 m·kg
Drain Plug	12 x 1.5: 2.0 m·kg
Cylinder Head Cover	Ø
Cylinder Head:	6 x 1.0: 1.0 m·kg
Engine Mounting Bolts: Front	8 x 1.25: 2.5 m·kg
Rear, Upper	8 x 1.25: 2.5 m·kg
Rear, Lower	8 x 1.25: 2.5 m·kg

Ø = Does Not Apply To This Model
NA = Information Not Available

*Available From Yamaha Parts Distributors Inc.
•For Diagnostic Use Only

MX80J 1982 SERVICE DATA

MODEL - ITEM I.D. NUMBER	MX80J	367
Initial Engine Number / Frame Number	367-654111 / 367-654111	
Basic Color(s)	Clean White	
Fuel Type / Fuel Tank Capacity / Reserve Capacity	Regular / 4.8 Lit. / 0.5 Lit.	
Dry Vehicle Weight	59 kg	
ENGINE TYPE	2-Stroke, Air-Cooled, Reed Valve	
Bore/Stroke/Number Cylinders/Displacement (cc)	47mm / 42mm / 1 / 72cc	
Compression Ratio/Compression Pressure Min~Max	6.8:1 / NA	
Piston Skirt Clearance New ~ Max	0.035 ~ 0.040mm / 0.1mm	
Ring End Gap Top / 2nd / 3rd	0.15 ~ 0.35mm / 0.15 ~ 0.35mm / Ø	
Valve Clearance (Cold) Intake / Exhaust	Ø	
Oil Pressure Hot / rpm	Ø	
Oiling System	Autolube	
Capacity: Dry	0.7 Lit.	
Oil and Filter Change	Ø	
Oil Change	Ø	
Lubricant: Temp. Above 5°C (40°F)	Yamalube 2 ⁺ or Equivalent	
Temp. Below 15°C (60°F)	Yamalube 2 ⁺ or Equivalent	
AUTOLUBE - Min Stroke / Color Code	0.20 ~ 0.25mm / Yellow	
Minimum Output @ 200 Cycles	0.50cc ~ 0.62cc	
Maximum Output @ 200 Cycles	3.64cc ~ 4.27cc	
VALVEJETS - Mtr. / Type / I.D. Number	Telkel / Y16P-3 / 367-61	
Main Jet / Pilot Jet	94 / 34	
Needle Jet / Jet Needle-Clip Position	2.080 / 049-2	
Slide Cutaway or Throttle Valve	1.0	
Float Level / Fuel Level	23.0mm ± 2.5mm / NA	
Idle rpm	1300 rpm	
Max CO [*] / Max HC [*] / Set CO	Ø	
SUSPENSION		
Front Forks: Oil Type / Level / Qty	10, 20, or 30 Wt. Fork Oil [*] / Ø / 112cc	
Gas Pressure	Ø	
Spring Length Std	386mm	
Monoshock: Oil Type / Qty	Ø	
Gas Pressure	Ø	
Minimum Brake Lining Thickness	Front: 2.0mm Rear: 2.0mm	
Tire Size (Nominal Pressure)	F: 2.50-15 (1.5 kg/cm ²) R: 2.75-14 (2.0 kg/cm ²)	
TRANSMISSION - Oil Type/Qty, Chg./Qty, Reasonable	SAE 10W30 SE / 550cc / 600cc	
Primary Drive Type / Teeth / Ratio	Helical Gear / 68-19 / 3.578	
Secondary Drive Type / Teeth / Chain	Chain / 41-14 / DID420-92L	
Clutch Friction Plate Thickness Std ~ Min	3.5 ~ 3.2mm	
Clutch Spring Length Std ~ Min	31.5 ~ 30.5mm	
Middle Gear Case Capacity	Ø	
Final Gear Case Capacity	Ø	
Gear Case Lubricant: Temp. Above 5°C (40°F)	Ø	
Temp. Below 16°C (60°F)	Ø	
All Weather Conditions	Ø	

SERVICE COPY	SER MGR	MECH	MECH	MECH	BINDER
OFFICE COPY	GEN MGR	SALES	PARTS	BINDER	PAGE 1 OF 2

CHARGING SYSTEM	Flywheel Magneto / Single Phase / Half Wave
Battery: Model / Specific Gravity / Charge Rate	Ø
Maximum Output	8V 4A @ 8000 rpm
TROUBLESHOOTING	
Field Coil Color Code / Ø	Ø
Charge Coil Color Code / Ø	Ø
IGNITION SYSTEM	Flywheel Magneto - External Rotor
Ignition Timing	1.8mm BTDC
Spark Plug Type	NGK B7HS
Spark Plug Gap / Torque / Cap Ø	0.5 ~ 0.6mm / 2.0 m·kg / 5K Ø ± 10%
Point Gap / Condenser Capacitance	0.3 ~ 0.4mm / 0.30 µF ± 10%
TROUBLESHOOTING	
Ignition Coil Test Gap / Primary Ø / Secondary Ø	6mm / 1.02 Ø ± 10% / 6.0K Ø ± 20%
Pulser Coil or Pickup Coil Color Code / Ø	Ø
Source Coil Color Code / Ø	Blk ~ Gnd / 1.34 Ø ± 10%
LIGHTING SYSTEM	
Headlight / Taillight / Signal Rating	Ø
TROUBLESHOOTING	
Lighting Coil Color Code / Ø	Ø
TORQUE VALUES	
Front Axle Nut	10 x 1.25: 4.0 m·kg
Front Axle Holder Nut	Ø
Rear Axle Nut	12 x 1.25: 6.0 m·kg
Rear Axle Pinch Bolt	Ø
Clutch Nut	12 x 1.0: 4.5 m·kg
Drain Plug	12 x 1.5: 2.0 m·kg
Cylinder Head Cover	Ø
Cylinder Head	6 x 1.0: 1.0 m·kg
Engine Mounting Bolts: Front	8 x 1.25: 2.5 m·kg
Rear, Upper	8 x 1.25: 2.5 m·kg
Rear, Lower	8 x 1.25: 2.5 m·kg

Ø = Does Not Apply To This Model
NA = Information Not Available

* Available From Yamaha Parts Distributors Inc.
* For Diagnostic Use Only

SERVICE LITERATURE

PUBLICATION	PART NUMBER	REMARKS
Owner's/Service Manual Assembly Manual	LIT-11626-03-09 LIT-11666-01-77	Same as MX80G, Supp. to GT80E (01-06)

CHARGING SYSTEM	Flywheel Magneto / Single Phase / Half Wave
Battery: Model / Specific Gravity / Charge Rate	⊖
Maximum Output	6V 4A @ 8000 rpm
TROUBLESHOOTING	
Field Coil Color Code / ⓪	⊖
Charge Coil Color Code / ⓪	⊖
IGNITION SYSTEM	Flywheel Magneto - External Rotor
Ignition Timing	4.8mm BTDC
Spark Plug Type	NGK B7HS
Spark Plug Gap / Torque / Cap ⓪	0.5 ~ 0.6mm / 2.0 m·kg / 5K ⓪ ± 10%
Point Gap / Condenser Capacitance	0.3 ~ 0.4mm / 0.30 μF ± 10%
TROUBLESHOOTING	
Ignition Coil Test Gap / Primary ⓪ / Secondary ⓪	6mm / 1.02 ⓪ ± 10% / 6.0K ⓪ ± 20%
Pulse Coil or Pickup Coil Color Code / ⓪	⊖
Source Coil Color Code / ⓪	Blk ~ Gnd / 1.34 ⓪ ± 10%
LIGHTING SYSTEM	
Headlight / Taillight / Signal Rating	⊖
TROUBLESHOOTING	
Lighting Coil Color Code / ⓪	⊖
TORQUE VALUES	
Front Axle Nut	10 x 1.25: 4.0 m·kg
Front Axle Holder Nut	⊖
Rear Axle Nut	12 x 1.25: 6.0 m·kg
Rear Axle Pinch Bolt	⊖
Clutch Nut	12 x 1.0: 4.5 m·kg
Drain Plug	12 x 1.5: 2.0 m·kg
Cylinder Head Cover	⊖
Cylinder Head	6 x 1.0: 1.0 m·kg
Engine Mounting Bolts: Front	8 x 1.25: 2.5 m·kg
Rear, Upper	8 x 1.25: 2.5 m·kg
Rear, Lower	8 x 1.25: 2.5 m·kg



⊖ = Does Not Apply To This Model
 NA = Information Not Available

* Available From Yamaha Parts Distributors Inc.
 * For Diagnostic Use Only

SERVICE LITERATURE		
PUBLICATION	PART NUMBER	REMARKS
Owner's/Service Manual Assembly Manual	LIT-11626-03-09 LIT-11666-01-77	Same as MX80G, Supp. to GT80E (01-06)