



YAMAHA

IT125G

ASSEMBLY MANUAL



LIT-11666-01-82

90894-07929

FOREWORD

This Assembly manual contains the information required for the unpacking and assembly of Yamaha motorcycles so that the Yamaha serviceman can assemble the machines in the correct manner. To perform machine assembly, a basic knowledge of service and Yamaha machines is required. Therefore all Yamaha dealers are urged to study the service of Yamaha motorcycles using the relevant service manuals. This Assembly Manual should be used in conjunction with the Owner's service manual and Parts list for this model.

NOTICE

The service specifications given in the Assembly manual are based on the model as manufactured. When this model may require improvements, the service specifications may be subject to change in the future. Modifications are inevitable and significant changes in specifications or procedures will be forwarded to Authorized Yamaha dealers. The assembly procedure is described in the order that the mechanic should follow, and the correct service tools should be used in the correct manner. Failure to do this may result in poor performance and harm to the rider.

Particularly important information is distinguished in this manual by the following notations:

NOTE: A NOTE provides key information to make procedure easier or clearer.

CAUTION: A CAUTION indicates special procedures that must be followed to avoid damage to the machine.

WARNING: A WARNING indicates special procedures that must be followed to avoid injury to a machine operator or person inspecting or repairing the machine.

IT125G

Assembly Manual

© 1979 by Yamaha Motor Corporation, U.S.A.,

1st. Edition, August 1979

**All rights reserved. Any reprinting or
unauthorized use without the written
permission of Yamaha Motor Corporation,
U.S.A., is expressly prohibited.**

Printed in U.S.A.

P/N LIT-11666-01-82

PREPARATION

To assemble the machine correctly, the following supplies and working space are required.

Supplies

Oils, greases, shop rags.

Work shop

The workshop where the machine is assembled should be clean and large. The floor should be level.

UNPACKING

Note on transportation

Use care not to butt the machine packed in the crate against a hard object or give it a heavy shock during transportation or in the service shop.

Procedure for unpacking

To remove the machine and parts packed in the cardboard crate, cut the vinyl bands around the box using scissors. Next, remove the exterior carton by lifting it straight up, and remove the foam tray and front wheel.

Remove the nails from each corner of the crate, and remove the struts.

Remove the front fender held between the rear tire and the rear fender.

Remove the headlight body assembly, cardboard crate, and semi double seat.

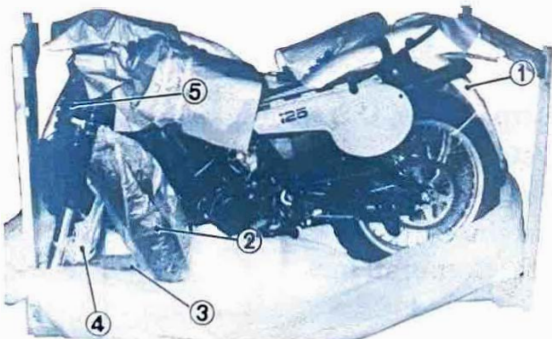

1. Front fender
2. Semi double seat
3. Card board crate
4. Headlight body assembly
5. Front wheel

Lift up the machine, and remove the rear wheel section from the lower wooden case. Then take out the machine.

Place a proper-size wooden box or a machine stand under the engine to keep the front of the machine raised off the floor. Take care so that the machine does not fall over.



PARTS CHECK LIST

Before starting the assembly, check for damaged or missing parts (listed below). Also check the machine for damage, scratches and other defects.

The following parts are contained in the cardboard box and the vinyl bag in the box. Check the quantity of parts. Also check for damage.

Parts list: Carton box

No.	Part name	Q'ty
1	Semi double seat	1
2	Front wheel	1
3	Front fender	1
4	Head light assembly	1



Part list: Foam tray

No.	Part name	Q'ty
1	Brake shoe plate (with brake wire)	1
2	Handlebar assembly	1
3	Speedometer assembly	1
4	Speedometer cable	1
5	Vinyl bag A	1

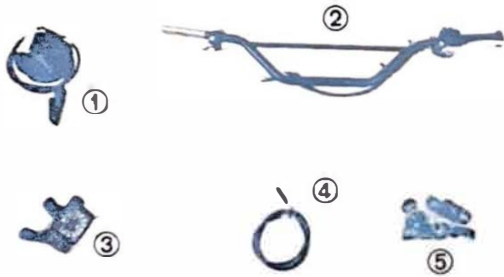

Part list: Carton box

No.	Part name	Q'ty
1	Owner's service manual	1
2	Tool kit	1
3	Wire holder	1
4	Headlight under bracket	1
5	Fuel tank breather hose	1
6	Vinyl bag B	1



Part list: Vinyl bag A

No.	Part name	Q'ty	Remarks
1	Handle upper holder	2	Handlebar
2	Flange bolt (d = 8mm, ℓ = 35mm)	4	
3	Collar	1	Front axle
4	Foot rest (right)	1	Foot rest
5	Foot rest (left)	1	
6	Clevis pin	2	
7	Hexagon head bolt with washer (d = 6mm, ℓ = 30mm)	2	Speedometer



www.legends-yamaha-enduros.com



Part list: Vinyl bag B

No.	Part name	Q'ty	Remarks
1	Washer (d = 6mm)	4	Front fender
2	Hexagon head bolt with washer (d = 6mm, ℓ = 20mm)	4	
3	Plate washer (d = 6mm)	4	
4	Panhead screw (d = 5mm)	1	Wire holder
5	Plate washer (d = 5mm)	1	
6	Nut (d = 5mm)	1	
7	Hexagon head bolt with washer (d = 6mm, ℓ = 12mm)	2	Semi double seat
8	Split pin (Large)	1	Front axle
9	Torsion spring	2	Footrest
10	Plate washer (d = 8mm)	2	
11	Split pin (Small)	2	
12	Collar screw	2	Headlight body (upper)
13	Panhead screw (d = 6mm)	2	
14	U-nut (d = 6mm)	2	
15	Plate washer	2	
16	Clamp	1	
17	Plate washer (d = 6mm)	2	Headlight body (lower)
18	Panhead screw with washer (d = 6mm)	2	

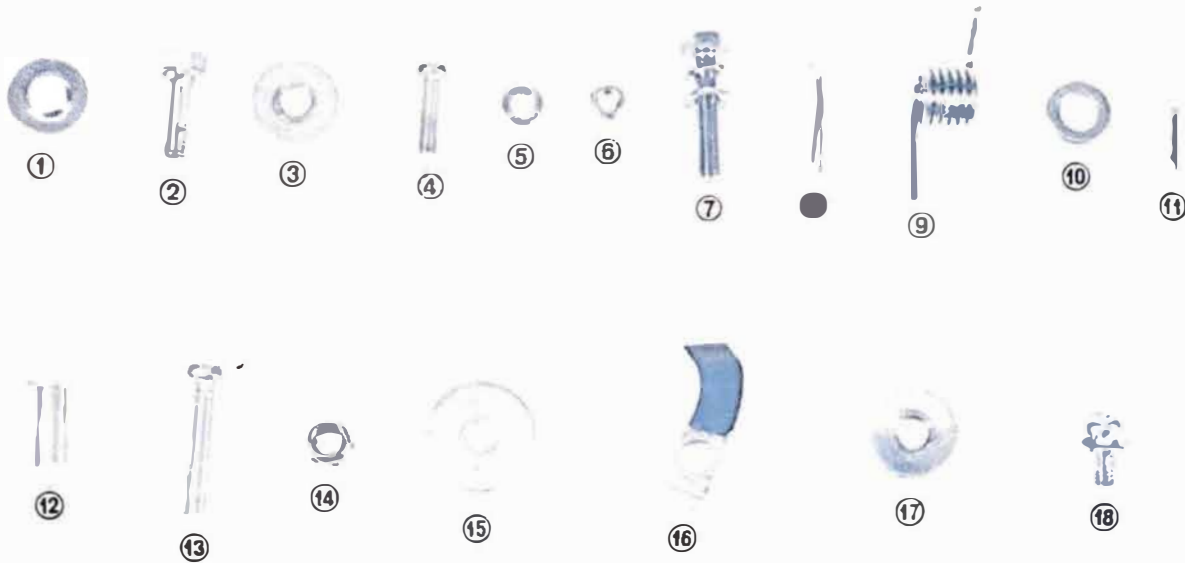

SET-UP PROCEDURES

1. Insert the front fender between the front forks, and secure the front fender using bolts with spring washers, plain washers, and washers. (See illustration)

Tightening torque: 0.45 m·kg (3.25 ft·lb)

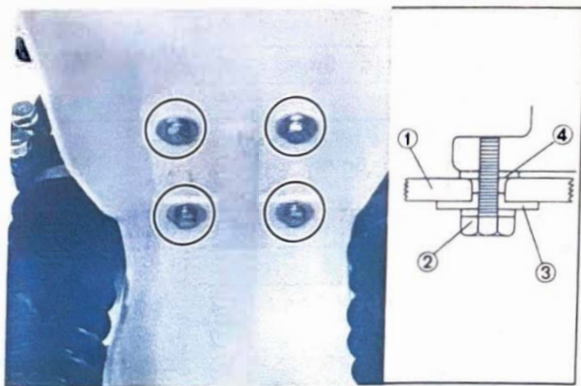

1. Front fender
2. Bolt with washer
3. Plate washer
4. Washer

2. Remove the front wheel axle nut and plain washer. Then remove the wheel axle.

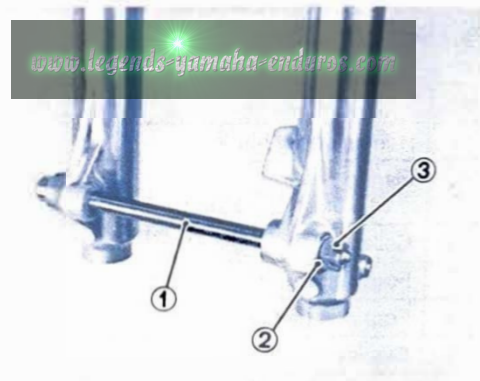

1. Wheel axle
2. Plain washer
3. Axle nut

3. Clean the brake shoe linings and wheel hub with a clean cloth.

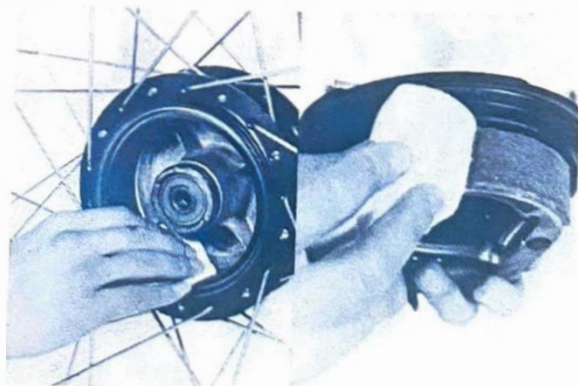

4. Install the brake shoe plate assembly in the front wheel hub.
 - a. Apply a light coat of grease to the speedometer drive gear and oil seal.

CAUTION:

Take care not to put grease on the brake linings or inner surface of the brake drum. If you do so, clean using a rag dampened with a solvent. Foreign material on braking surface can cause impaired braking action.

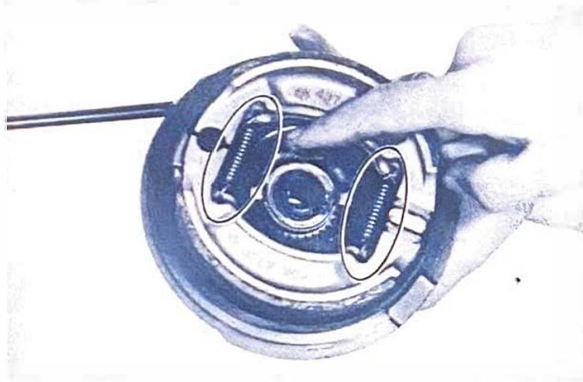

- b. Make sure the brake shoes and springs are correctly installed in the shoe plate assembly. If any one of them is out of position, correct per the figure.
 - c. Install the brake shoe plate assembly in the wheel hub.

NOTE:

Make sure the two legs in the wheel hub align with the two slots in the speedometer clutch assembly.

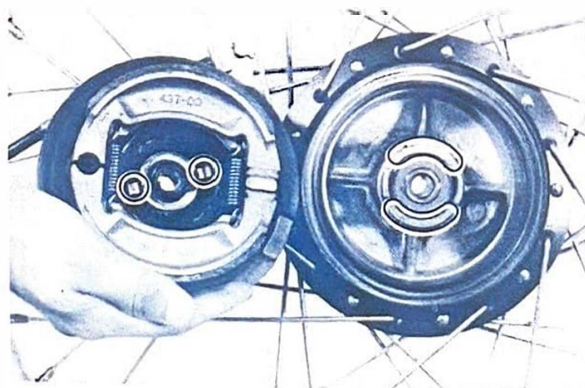

5. Install the wheel axle collar in the wheel hub on the right side of the front wheel.

NOTE:

To avoid damaging the oil seal lip, apply a light coat of lithium base grease to the oil seal lip and collar. If the collar has dirt, clean with a rag.

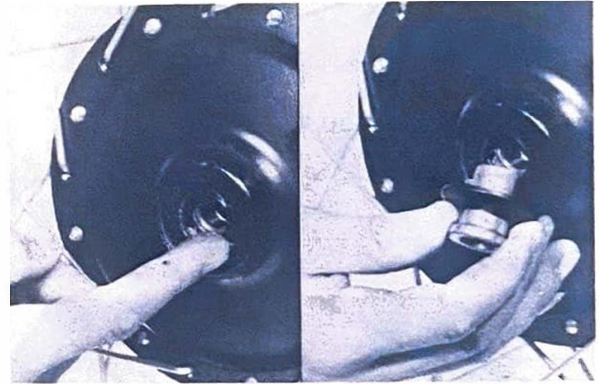

6. Install the front wheel on the front forks.
 - a. Insert the front wheel between the front fork legs so that the stopper (projection) on the front fork end has correctly engaged the slot in the brake shoe plate.



- b. Apply grease to the axle and install the axle nut and plain washer.



c. Torque the axle nut to specification.

Tightening torque: 4.8 m-k_g (35 ft-lb)

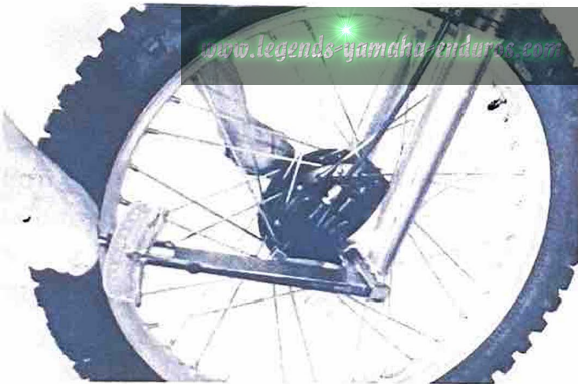

d. Lock the nut with the cotter pin. The pin should be inserted downward, and the pin ends should be bent.

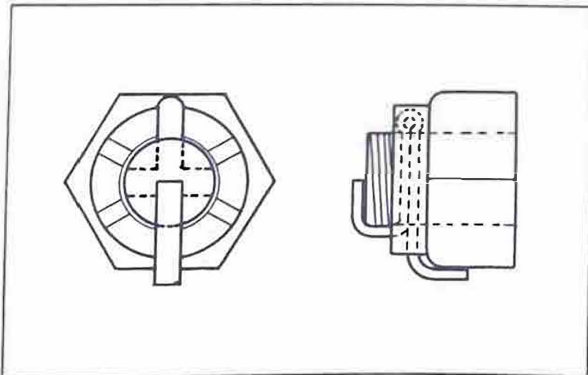

7. Connect the speedometer cable to the front wheel hub gear unit. Insert the cable end into the gear unit, fit the circlip in the groove on the wheel hub side, and lock the cable. (The circlip is already attached to the cable.)

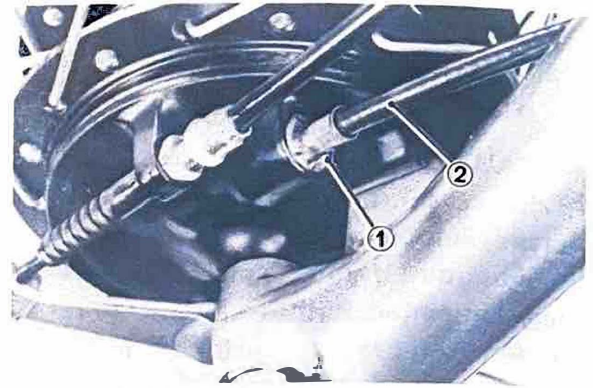

1. Circlip 2. Speedmeter cable

8. Wire holder installation

- a. Install the wire holder to the left side fork leg so that the stopper (projection) on the leg is correctly engaged the hole in the wire holder as shown.
- b. Secure the wire holder.

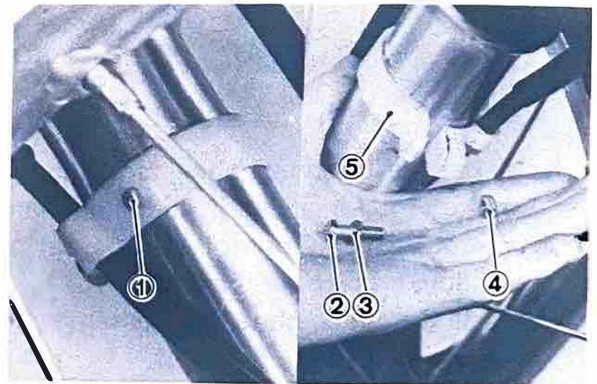

1. Stopper 3. Washer 5. Wire holder
2. Panhead screw 4. Nut

9. Install the speedometer assembly under the handle crown and secure the speedometer.

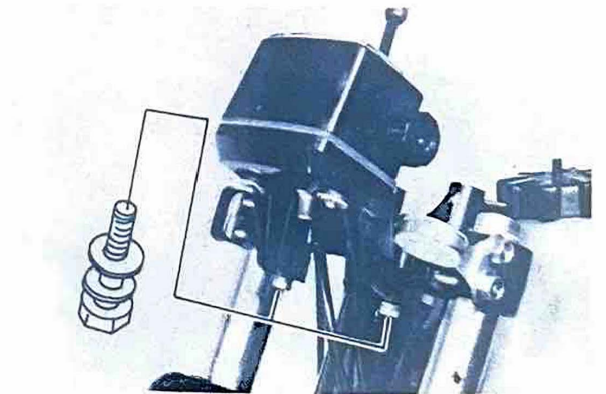

Tightening torque: 1.0 m-k_g (7.2 ft-lb)

10. Connect the speedometer cable to the speedometer.

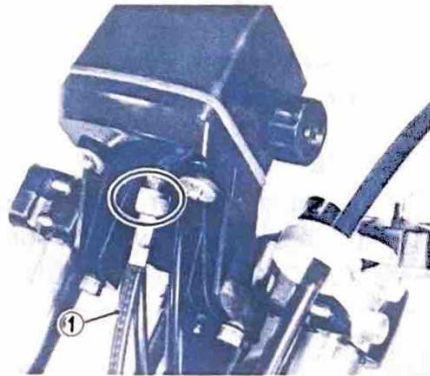

1. Speedometer cable

11. Pass the front brake wire through three wire holders. Tighten the screw.

*For detailed cable routing, refer to "CABLE ROUTING DIAGRAM".

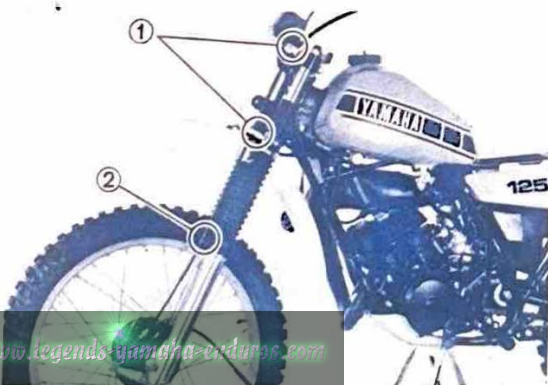

1. Wire holder 2. Clamp

12. Wipe off any dust on right handlebar end, and apply a light coating of grease to handlebar end and throttle grip housing. Install the throttle grip.

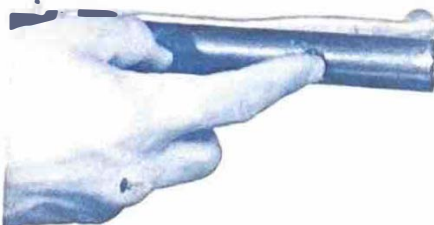

13. Install the handlebars using the two upper holders and four flange bolts as shown.

Tightening torque: 1.5 m·kg (11 ft·lb)

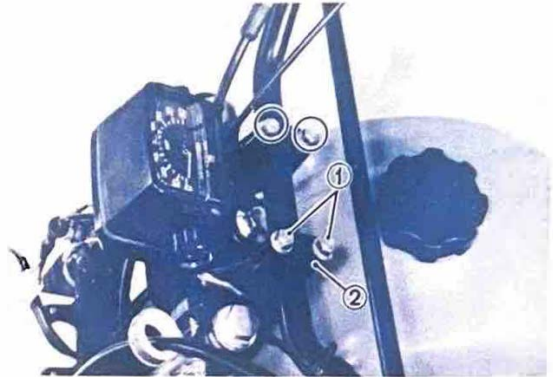

1. Flange bolt 2. Upper holder

CAUTION:

First tighten the bolt on the front end of holder, and tighten the bolt on the rear end.

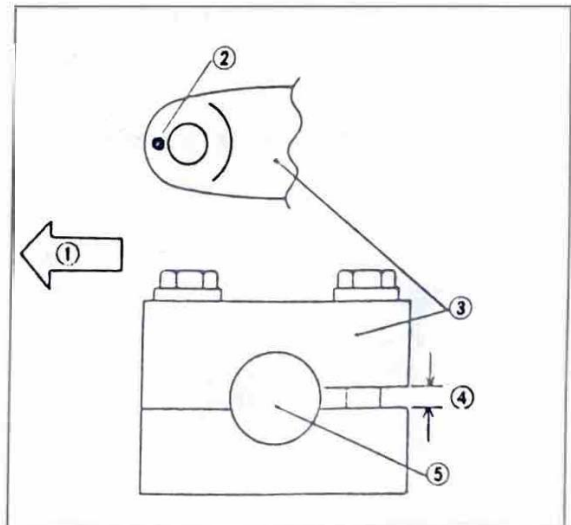

1. FWD 2. Punch mark 3. Upper holder 4. Gap 5. Handlebar

14. Slip the throttle grip over the handle lever to the limit and slide it back about 5 mm (0.5 in), and assemble the throttle housing using the screws provided.

Check to see that the throttle grip moves smoothly.

CAUTION:

Tighten the screws in the stages and maintain an equal gap on each side of holder.

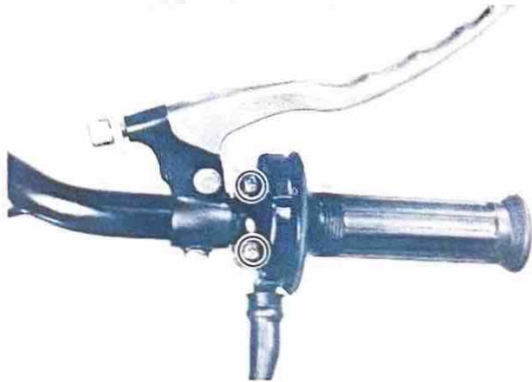

15. Brake wire and clutch wire installation

NOTE:

Before assembly, lubricate cables with suitable cable lubricant.

- a. Screw in the cable length adjusters on the brake shoe plate (brake wire) and cable length adjuster (clutch wire).

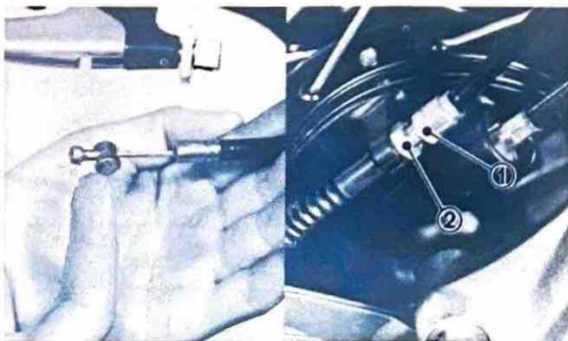

1. Lock nut
2. Adjuster

- b. Fully loosen the lever adjuster lock nut and screw in the adjuster until tight. Next, align the slits in the adjuster and adjuster lock nut with the slit in the lever holder.

- c. Insert the wire end into the lever hole, and hook the outer cable end onto the adjuster lock nut, then squeeze the lever. Next, while pulling outer cable in the direction opposite the lever, release the lever quickly. While releasing it, seat the outer cable into the adjuster.

WARNING:

Proper cable and wire routing is essential to insure safe vehicle operation, refer to "CABLE ROUTING DIAGRAM".

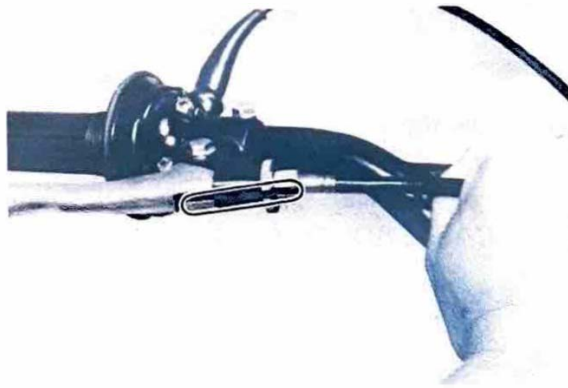

- d. Cover the brake and clutch lever holders with holder covers.



1. Holder cover

CABLE ROUTING DIAGRAM

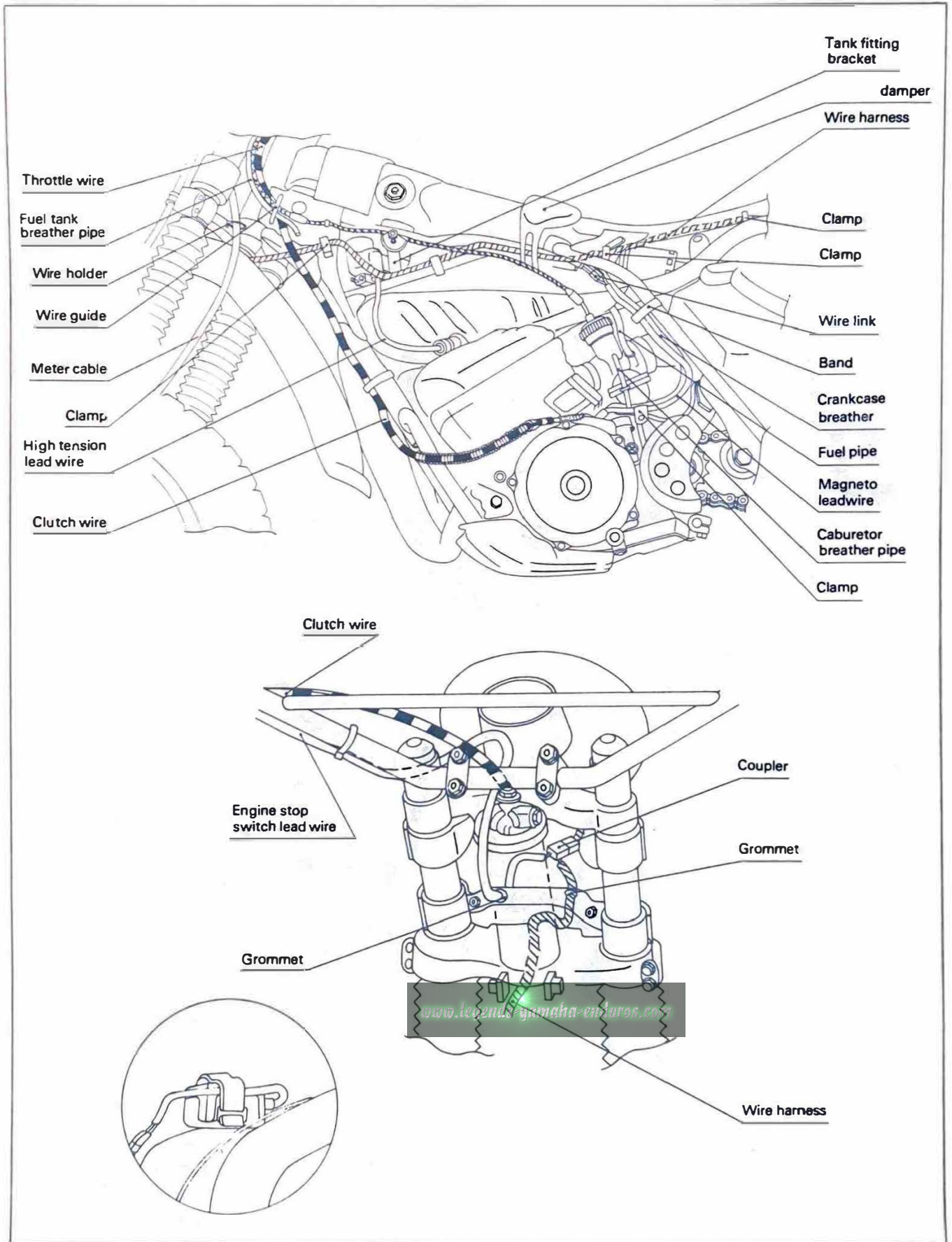

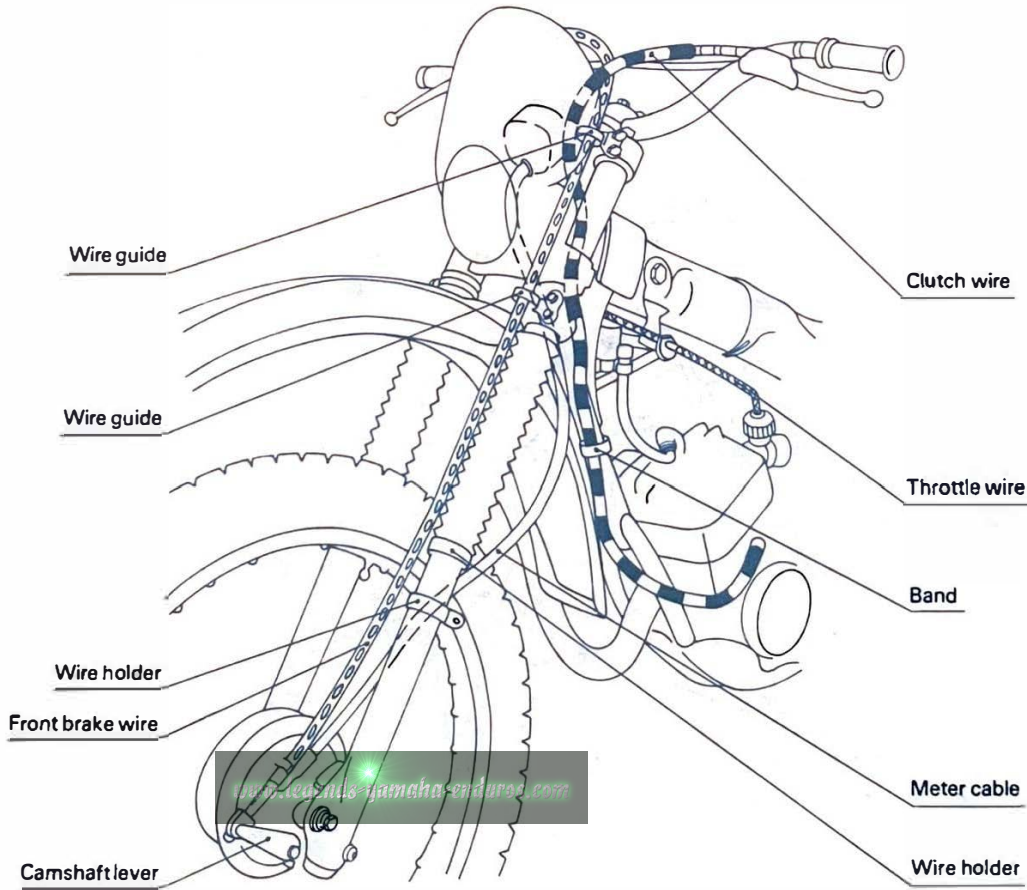
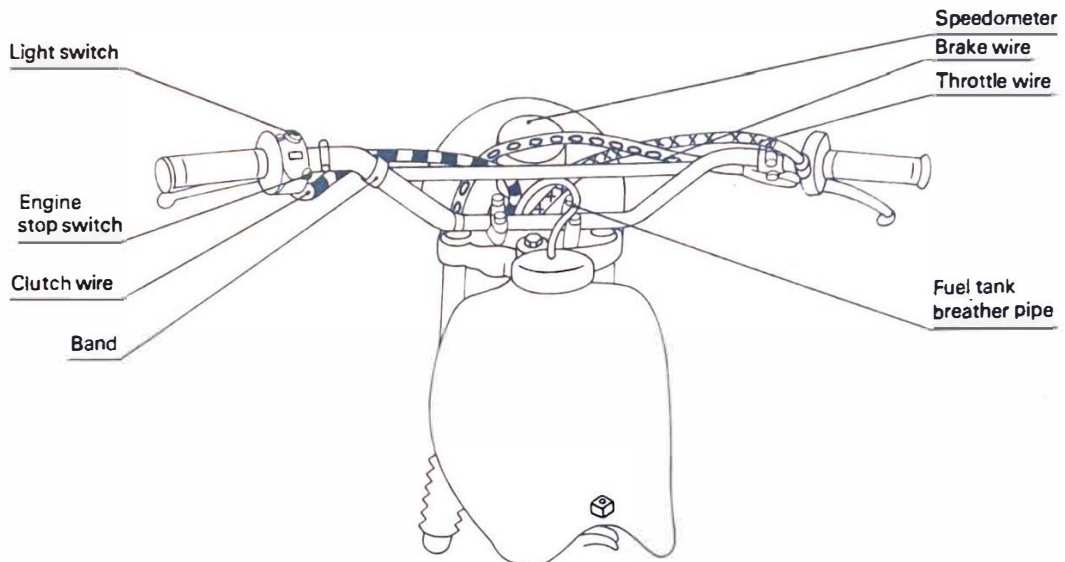

WARNING:

Follow correct routing of all items in this diagram. Failure to do so could result in unsafe assembly of the machine.

16. Headlight installation

- a. Place the headlight under-bracket between the front forks and install the grommet, which is attached to the wire harness, on the bracket.

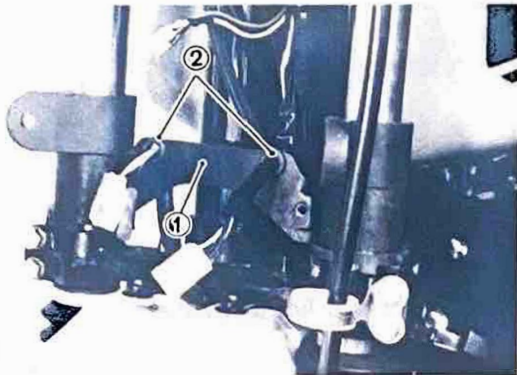

1. Under bracket 2. Grommet

- b. Connect the wire harness, headlight switch wire and headlight lead wires through couplers.

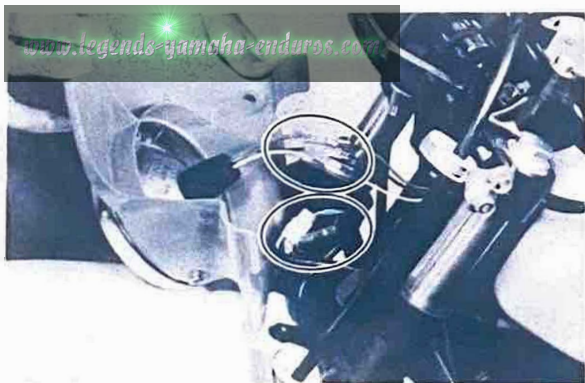

- c. When securing the upper part of the headlight assembly, the headlight unit must be removed from the headlight body.

- d. Install the headlight assembly on the front fork.

When tightening the left side bolt, secure the clamp at the same time.

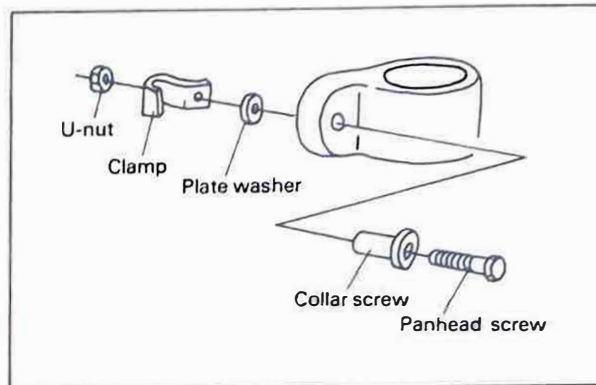

1. Clamp

- d. Install the headlight assembly on the front fork.

- e. Install the headlight unit assembly on the headlight body.

- f. When installing the headlight lens assembly, care should be used so that wires are not pinched.

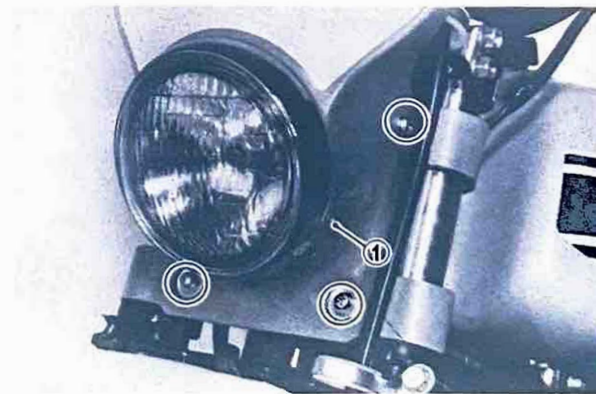

1. Screw with washer

17. Fuel tank breather pipe installation
Pass through between the handle crown and meter bracket and let it hang down.



18. Footrest installation
Install the footrest to both right and left sides of the lower part of the frame.

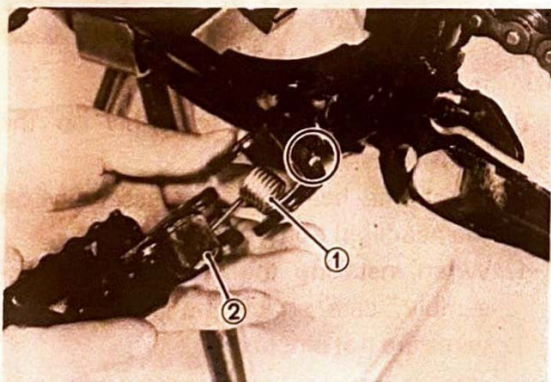

1. Torsion spring 2. Foot rest

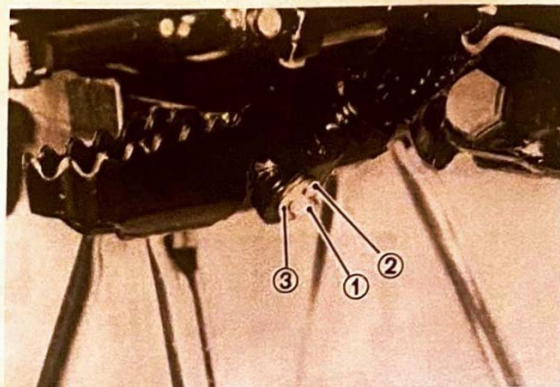

1. Clevis pin 2. Cotter pin 3. Plate washer

19. Seat installation
Insert the hook on the end of the seat into the frame, and secure both sides of the seat with hexagon head bolts with washers.

Tightening torque: 1.0 m·kg (7.2 ft·lb)

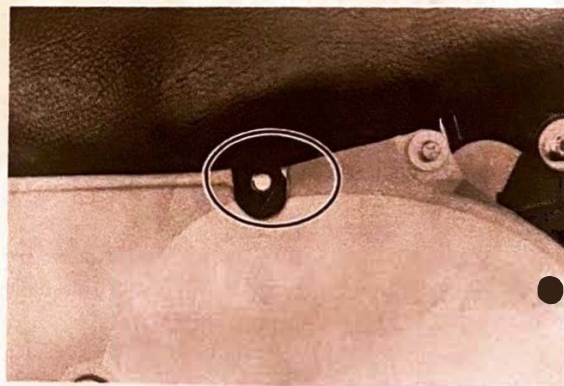

INSPECTIONS AND ADJUSTMENTS

Inspections

After all packed parts are installed, check to see that all these parts and other parts (mounted or installed at the Yamaha factory) are correctly mounted or installed, or tightened to specification. This check-up should be started with the front of the machine.

Item

Front wheel spokes Tension
Front wheel rim Deflection
Front wheel tire Tire pressure
Front wheel axle nut Cotter pin, Tightening torque
Steering head Adjustment, Tightening torque
Handle holder Tightening torque
Clutch lever Freeplay, Tightening torque
Clutch wire Routing, Lubrication
Brake lever Freeplay, Tightening torque
Front brake wire Routing, Lubrication
Throttle wire Routing
Throttle housing Position, Operation, Freeplay
Carburetor joints Tightness
Footrest Position, Tightness
Change pedal Tightness, Operation

Brake pedal Position, Freeplay, Operation
Seat Mounting
Fuel tank Mounting
Fuel pipe Routing, Connection
Rear fender Mounting
Taillight Mounting, Routing
Fuel breather pipe Routing, Connection
Rear shock absorber Cotter pin, Mounting
Swing arm pivot shaft Tightening torque
Rear wheel axle nut Cotter pin, Tightening torque
Rear wheel Spoke tension
Rear wheel rim Deflection
Rear wheel tire Tire pressure
Handle switch lead wire Routing, Clamp
Speedometer cable Routing
Transmission Oil level

Adjustments

NOTE:

This section deals with the main points only. For details, refer to the owner's service manual for this model.

Front brake adjustment

Front brake should be adjusted to suit rider preference with a minimum cable slack of 5 ~ 8 mm (0.2 ~ 0.32 in) play at the brake lever pivot point.

1. Loosen the adjuster lock nut.
2. Turn the cable length adjuster in or out until adjustment is suitable.
3. Tighten the adjuster lock nut.

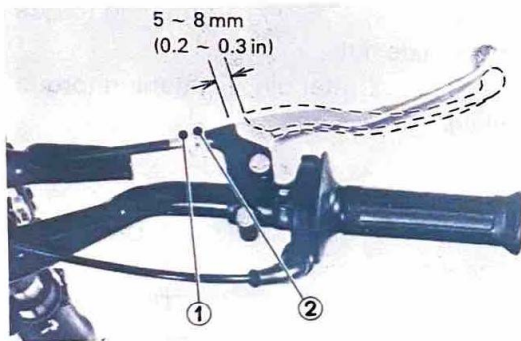

1. Adjuster 2. Lock nut

Clutch wire adjustment

Loosen the clutch wire adjuster lock nut at the clutch lever, and adjust the clutch wire by turning the wire adjuster.

Turning the adjuster clockwise (the adjuster is tightened) increases clutch wire play, while turning counterclockwise decreases the play. The play should be 2 ~ 3 mm (0.08 ~ 0.12 in) at the position shown in the figure.

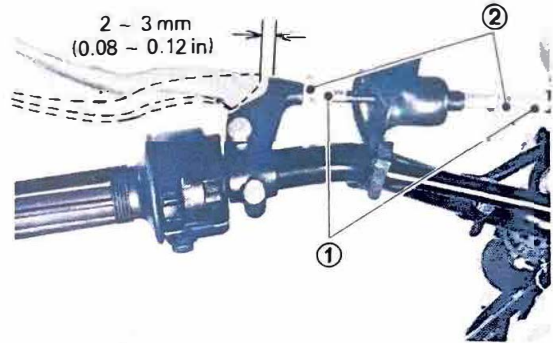

1. Lock nut 2. Adjuster

Throttle cable freeplay adjustment

Check play in turning direction of throttle grip. The freeplay should be 3 ~ 5 mm (0.12 ~ 0.20 in) at grip flange, loosen the lock nut and turn the adjuster to make the necessary adjustment. After adjusting, be sure to tighten the lock nut properly.

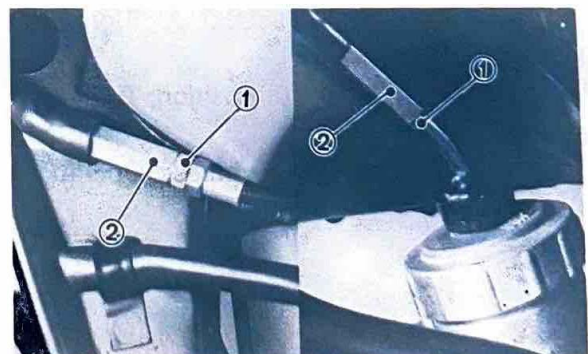
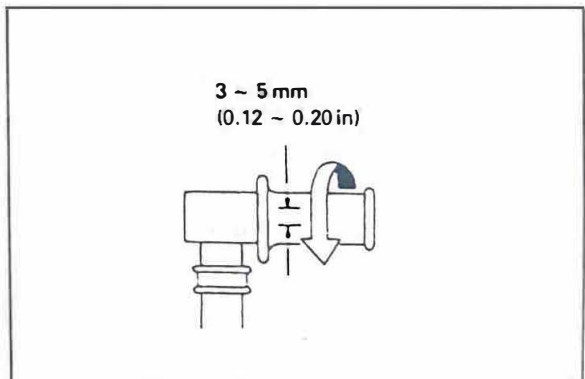

1. Lock nut 2. Adjuster

Troubleshooting

If the engine will not start or will not start easily after inspections and adjustment, check the following parts.

1. Ignition timing — Checking and adjustment

After starting the engine, check the ignition timing, and if necessary, adjust.

Ignition timing (B.T.D.C.):
 24° at 2,000 r/min
 (−2.6 mm ± 0.15 mm/
 0.102 in ± 0.006 in)

2. Spark plug — Checking and adjustment
 When the machine is stored or not used for a long period of time, the spark plug may get with oil. If so, hard starting will result, remove the spark plug, and clean as required.

Spark plug:
 Type N-2G (CHAMPION)
 Gap 0.7 mm (0.028 in)

3. Carburetor — Cleaning

Remove the drain screw attached to the carburetor float bowl, and drain off the fuel. Add fresh fuel.

NOTE: _____
 For details, refer to the Owner's service manual for this model.

TORQUE SPECIFICATIONS

The following torque specifications must be adhered to on every machine. Components with several studs should be tightened in gradual stages and in a pattern that will avoid warpage to the item being secured.

Torque settings are for dry, clean threads. Torquing should always be done to the nut, never the bolt head.

NOTE: _____
 Certain items with other than standard thread pitches may require differing torque. Consult the model Owner's service manual or distributor if a question arises.

A (Nut)	B (Bolt)	Standard tightening torque	
		m-kg	ft-lb
10 mm	6 mm	0.6	4.5
12 mm	8 mm	1.5	11
14 mm	10 mm	3.0	22
17 mm	12 mm	5.5	40
19 mm	14 mm	8.5	61
22 mm	16 mm	13.0	94

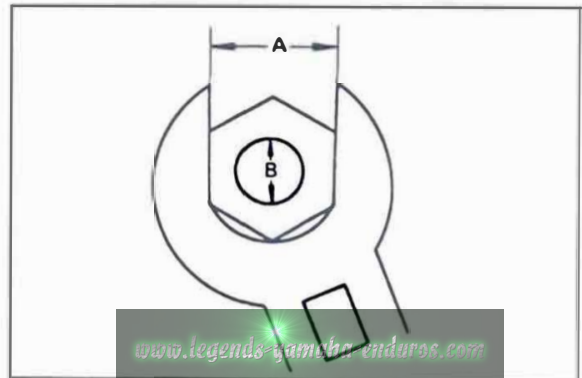

www.legends-yamaha-enduros.com



YAMAHA MOTOR CO., LTD.

IWATA, JAPAN

PRINTED IN U.S.A.