

GENUINE



GT MXD

OWNER'S MANUAL

www.legends-yamaha-enduros.com

LIT-11626-00-35

INTRODUCTION

Thank you for buying the Yamaha GTMXD.

This is a small model but it has most of the equipment used on larger models. It can be easily handled by the wife and children, too. This manual is written in such a way as to provide the owner with a good understanding of the operation, maintenance and inspection of this vehicle. All information required for safe and reliable use of the vehicle is contained in this manual, so read it carefully and completely before operating the vehicle. If you have any questions concerning the information, ask your dealer before operating the vehicle.

NOTICE: _____

Some data in this manual may become outdated due to improvements made to the machine in the future. If there is any question concerning this manual, consult your nearby Yamaha dealer.

GTMXD OWNER'S MANUAL

1st Printing - December 1976

2nd Printing - September 1979 JEM

ALL RIGHTS RESERVED BY
YAMAHA MOTOR CORPORATION, U.S.A.
BUENA PARK, CALIFORNIA 90620

LIT-11626-00-35

CONTENTS

NOMENCLATURE	1
MACHINE IDENTIFICATION	2
CONTROL FUNCTIONS	3
PRE-OPERATION CHECK	8
OPERATION AND IMPORTANT DRIVING POINTS	10
PERIODIC MAINTENANCE AND MINOR REPAIR	14
CLEANING AND STORAGE	48
SPECIFICATIONS	51

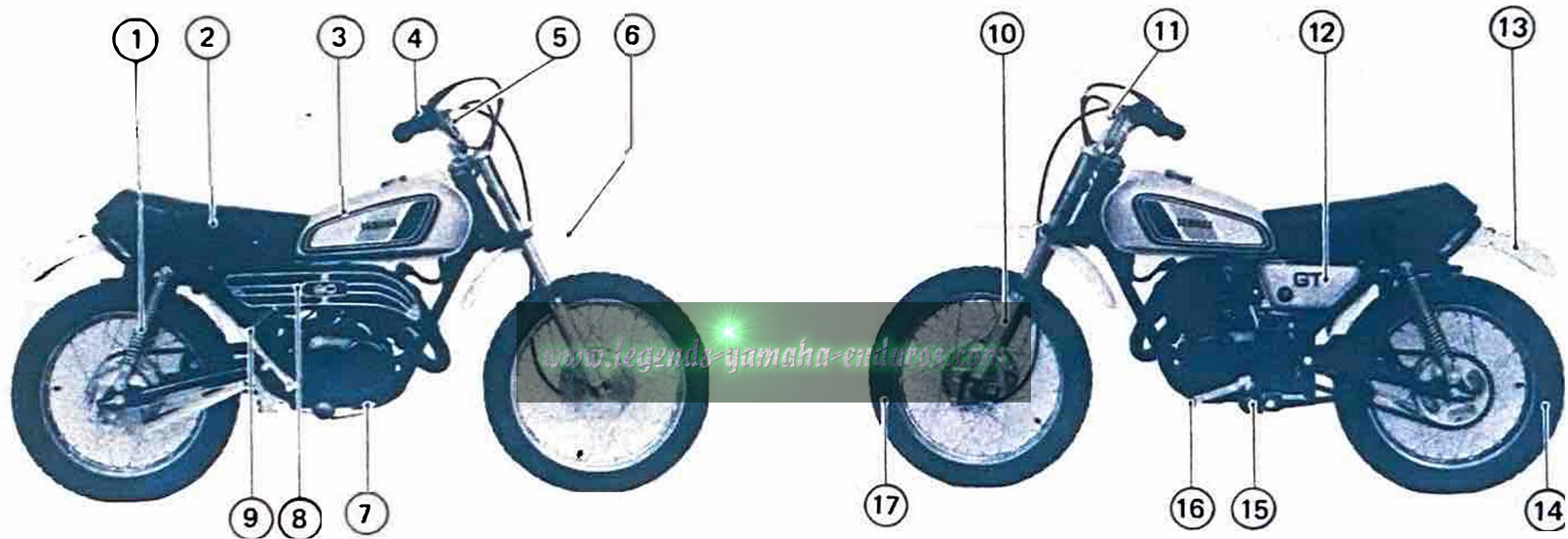

1. Rear shock absorber
2. Seat
3. Fuel tank
4. Throttle grip
5. Front brake lever
6. Front fender
7. Brake pedal
8. Muffler
9. Kick crank

10. Front fork
11. Clutch lever
12. Oil tank
13. Rear fender
14. Rear wheel
15. Footrest
16. Change pedal
17. Front wheel

MACHINE IDENTIFICATION

Frame number

The frame number is stamped on the right side of the steering head pipe.

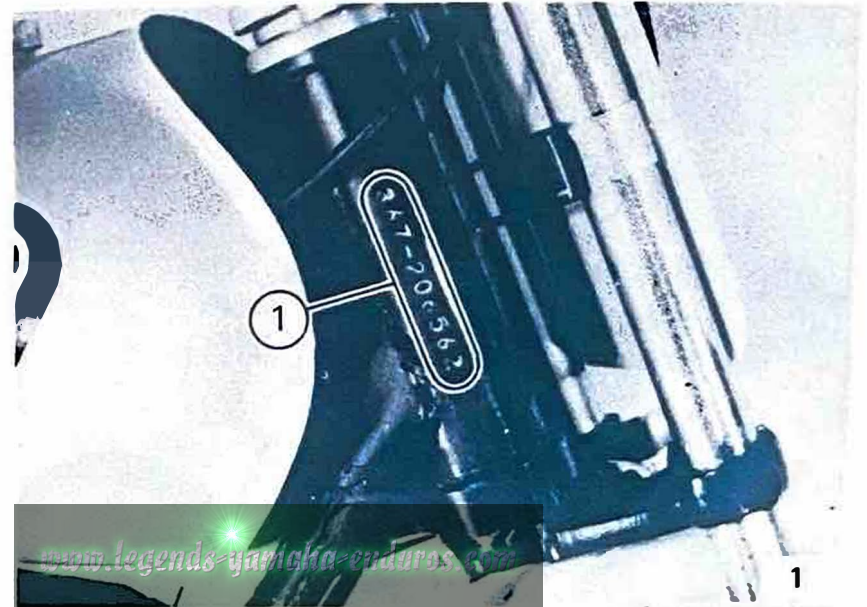

1
1 Frame number

Engine number

The engine serial number is stamped into the left side of the engine on top of the crankcase.

NOTE: _____

The first three digits of these numbers are for model identifications; the remaining digits are the unit production number. The two serial numbers are usually identical.

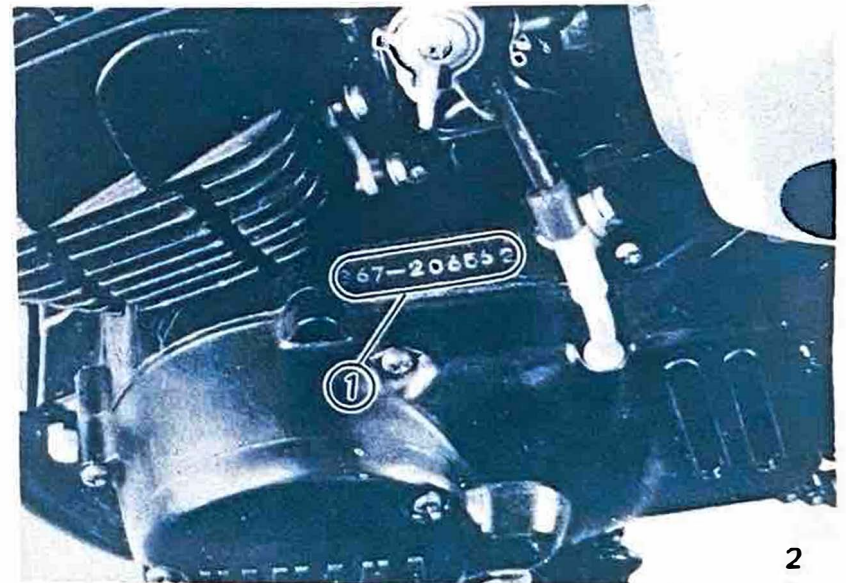

2
1 Engine number

CONTROL FUNCTIONS

Handle switches

The handle switches are located near the right handle grips and are used for the following functions:

“ENGINE STOP” switch

Make sure that the engine stop switch is on “RUN”. To stop the engine, turn the engine stop switch “OFF”. The engine switch has been equipped to ensure safety in an emergency such as when the motorcycle is upset or trouble takes place in the throttle system.

The engine will not start when the engine switch is turned to “OFF”.



3
1. “ENGINE STOP” switch

Fuel petcock

The fuel petcocks function to supply fuel from the tank to the carburetor and also to filter the fuel.

The fuel petcocks have the following three positions:

OFF: With the lever in this position fuel will not flow. Return the lever to this position when the engine is not running.

ON: With the lever in this position fuel flows to the carburetor. Normal driving is done with the lever in this position.

RES: This indicates reserve. If you run out of fuel while driving, move the lever to this position. Then, fill the tank at the first opportunity.

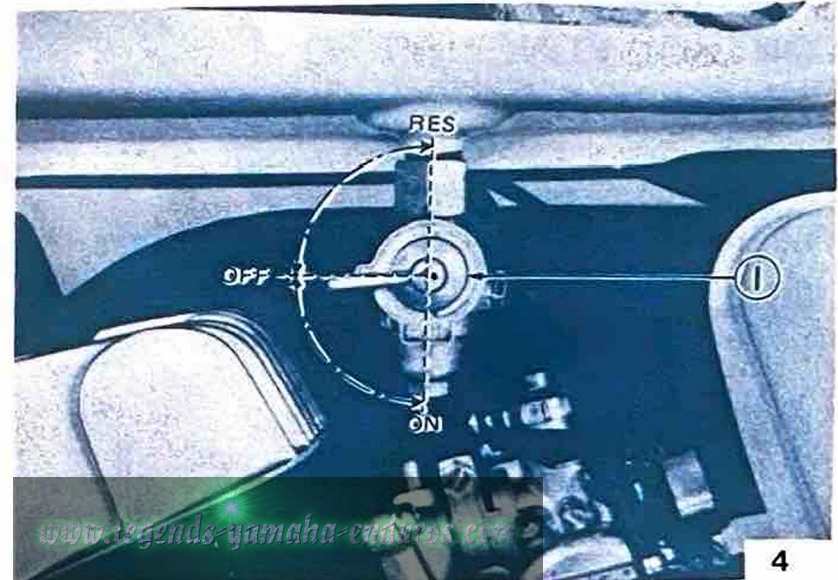

1. Fuel petcock

Front brake lever

The front brake lever is located on the right handle bar; pivot it forward the handlebar to activate the front brake.

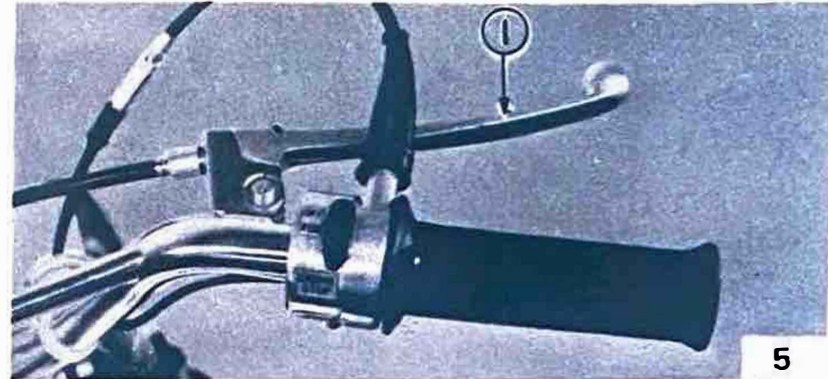

1. Front brake lever

Rear brake pedal

The rear brake pedal is on the right side of the motorcycle and activates the rear brake through a link rod.



1. Rear brake pedal

Clutch lever

The clutch lever is located on the left handlebar and disengages or engages the clutch. Pivot the clutch lever to the handlebar to disengage the clutch and release the lever to engage the clutch. The lever should be pulled rapidly and released slowly for smooth starts.

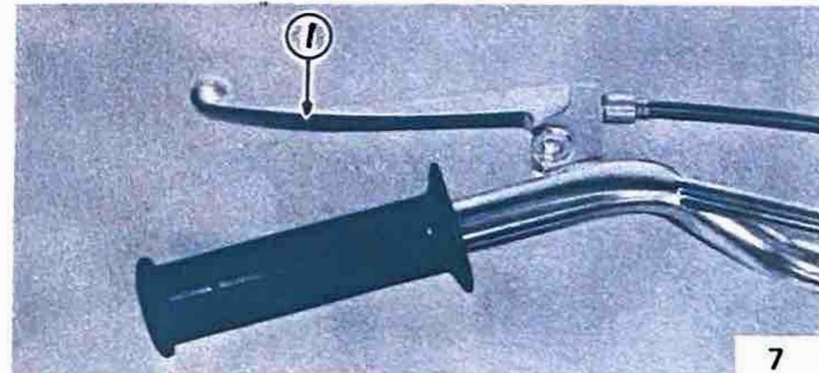

1. Clutch lever

Gear shifting

The gear ratios of the constant mech 4 speed transmission are ideally spaced. The gears can be shifted by using the change pedal on the left side of the engine. Refer to the illustration for the gear shifting pattern.

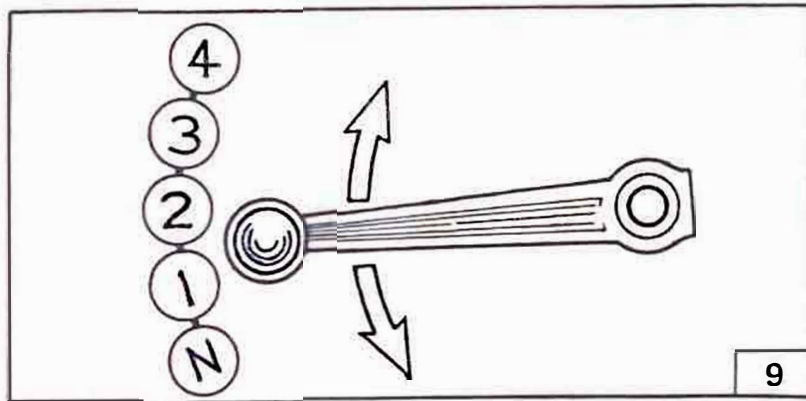

Starter lever (choke lever)

When cold the engine requires a richer fuel mixture for starting. A separate starter circuit, which is controlled by the starter lever, supplies this mixture. Push the lever down to open the circuit (for starting) and pull it up to close the circuit.

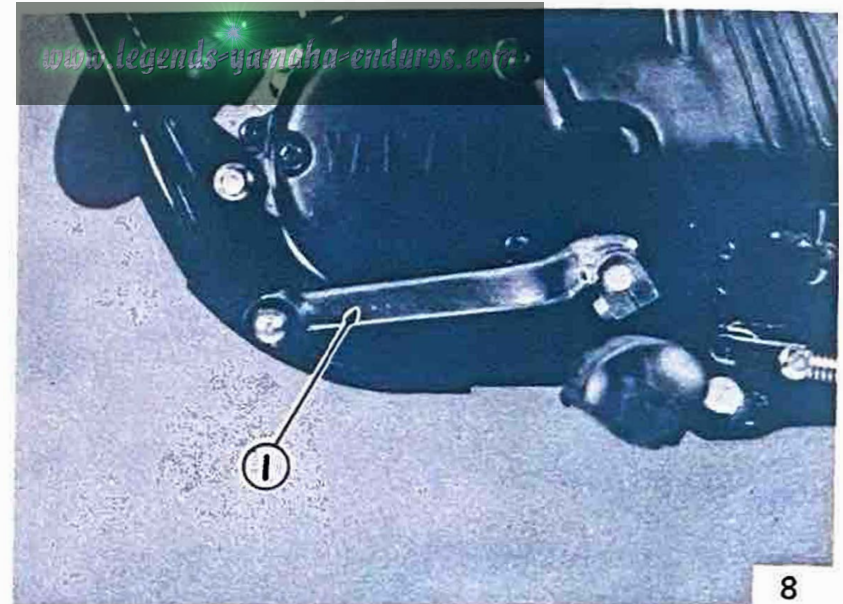

8
1. Change pedal

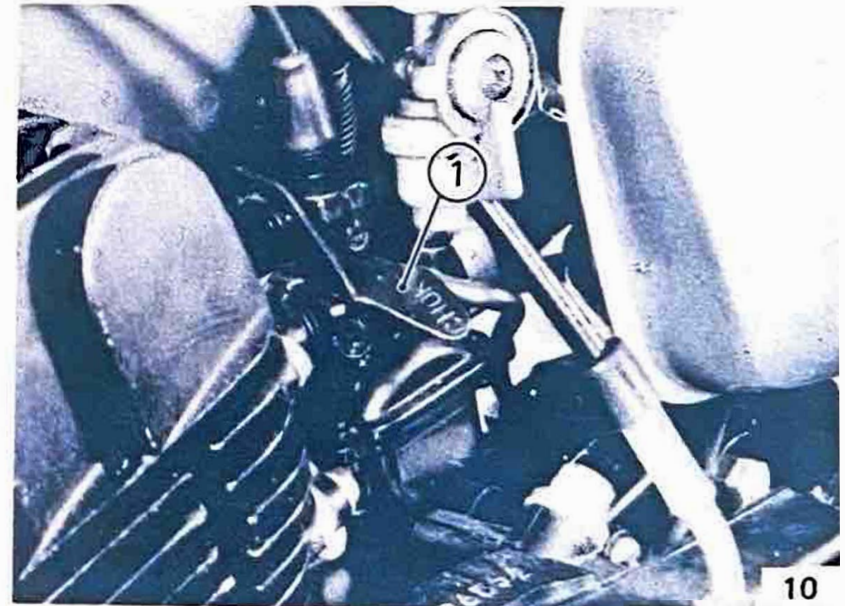

10
1. Starter lever

Engine oil tank

The engine oil tank holds the engine oil. The quantity can be measured with the oil level gauge. Add oil as soon as possible if the level drops to the lower line of the gauge.



11

1. Oil level gauge

Kick starter

To start the engine, rotate the kick crank, push down lightly with foot until gears engage, and then kick with full strength. This model has the primary kick starter so the engine can be started in gear if the clutch is disengaged. As normal practice, however, shift to neutral before starting.

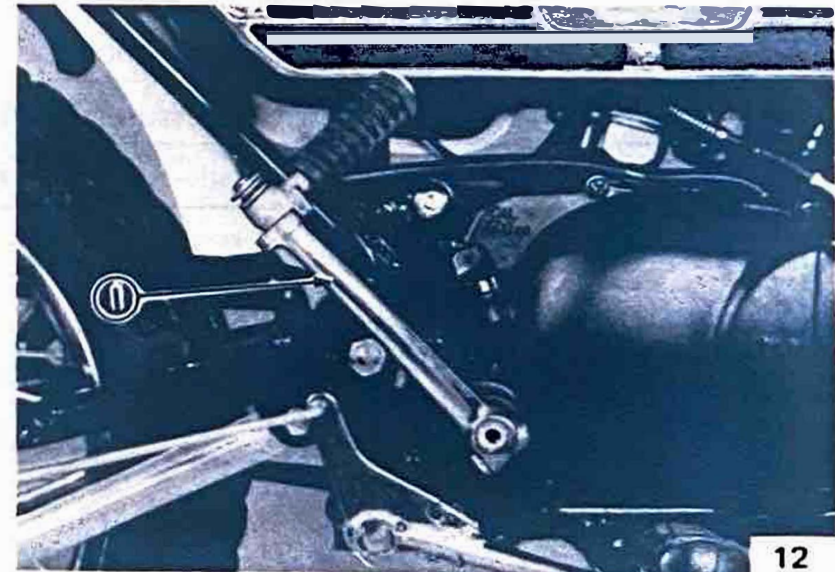

12

1. Kick starter

PREOPERATION CHECKS

Before using this motorcycle please check the following points:

Item	Routine	Page
Brakes	Check operation/adjustment	9,33,34
Clutch	Check operation/lever adjustment	9,31
Autolube tank	Check oil level/top-off as required	9,19
Transmission	Check oil level/top-off as required	9,20,21
Drive chain	Check alignment/adjustment/lubrication	34~36
Spark plug(s)	After break-in check color/cond'n weekly	22,23
Throttle	Check for proper throttle and autolube cable operation	9,28
Air filter	Foam type—must be clean and damp w/oil always	24,25
Wheels and tires	Check pressure/runout/spoke tightness/axle nuts	9,38-46
Fittings/fasteners	Check all—tighten as necessary	—

NOTE:

Pre-operation checks should be made each time the machine is used. Such an inspection can be thoroughly accomplished in a very short time; and the added safety it assures is more than worth the time involved.

Fuel

Make sure there is sufficient fuel in the tank.

Recommended gasoline: 90 octane

Fuel tank capacity:
4.8 lit (1.3 u.s. gal.)

Engine oil

Make sure there is sufficient engine oil in the oil tank. Add oil as necessary.

Recommended oil:

See page 19, "Engine oil section"

Oil tank capacity:
0.7 lit (0.74 u.s. qt.)

Transmission oil

Make sure the transmission oil is at the

specified level. Add oil as necessary.

Recommended oil:

Yamalube 4-cycle oil or, SAE 10W/30
type "SE" motor oil

Oil quantity:
500 cc (0.53 u.s. qt.)

Tires

Check the tire pressure and check the tires for wear.

Tire pressure

Front	0.9 ~ 1.1 kg/cm ² (13 ~ 16 psi)
Rear	0.9 ~ 1.1 kg/cm ² (13 ~ 16 psi)

Brake lever and brake pedal

Check for correct play in the brake lever and pedal and make sure they are working properly. Check the brakes at low speed shortly after starting out.

Clutch lever

Check for correct play in the clutch lever and make sure the lever operates properly.

Throttle grip

Turn the throttle grip to see if it operates properly and if the play is normal. Make certain the throttle springs closed when released.

OPERATION AND IMPORTANT DRIVING POINTS

CAUTION: _____

Before riding this motorcycle, become thoroughly familiar with all operating controls and their function.

Consult your Yamaha dealer regarding any control or function you do not thoroughly understand.

Starting a cold engine

1. Turn the fuel petcock to "ON".
2. Turn the engine stop switch to the "RUN" position.
3. Operate the carburetor starter jet (choke) lever and completely close the throttle grip.
4. Kick the kick crank with full strength to start the engine.
5. After the engine starts, warm up for one or two minutes. Make sure the starter jet (choke) lever is returned to the original position before driving.

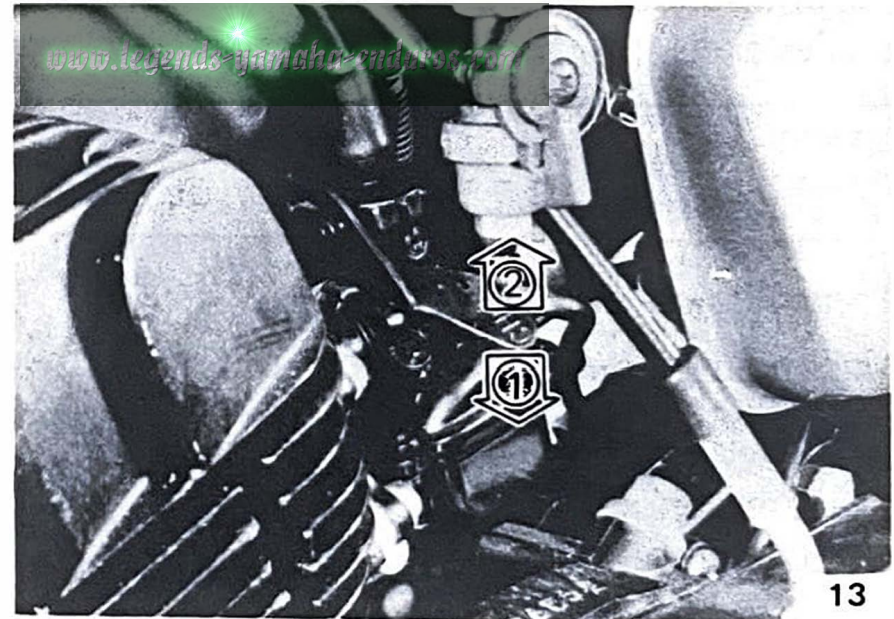

1. Open 2. Closed

Starting a warm engine

1. Turn the fuel petcock to "ON".
2. Turn engine stop switch to "RUN".
3. Slightly open the throttle grip.
4. Kick the kick crank with full strength to start the engine.

NOTE: _____

Do not operate the starter jet (choke) lever when the engine is already warm.

CAUTION: _____

See "Break-in Section" prior to operating engine for the first time.

Warming up

To get maximum engine life, always "warm-up" the engine before starting off. Never accelerate hard with a cold engine! To see whether or not the engine is warm, see if it responds to throttle normally with the starter jet (choke) turned off.

Brake operation

Brakes are provided to stop the moving motorcycle; however, care must be exercised when braking at high speeds or under poor driving conditions such as rough roads, snow rain, etc. Several braking methods are described below for your information. Pulling in the clutch lever and twisting the throttle grip in the closed direction will permit you to gradually glide to a stop. Downshifting through the gears, using the drag of the engine to slow down is another. However, the best method, and the one most universally used, is to use both engine braking (downshifting through the gears as the machine slows) and the front and rear brakes. After the rear brake starts to take hold, gradually apply the front brake. Since excessive braking pressure will cause the wheel to lock and skid, the rider must use both brakes with moderate pressure to get. Maximum stopping power without losing control. As the machine continues to slow, shift down through the gears using engine brake to aid the slowing effect.

Use the engine brake when descending long, steep hills. Do not operate the brakes continuously for very long periods. Use at repeated intervals. Special care is required in braking on poor roads and in bad weather. If the front brake is applied too strongly in such conditions the wheel may lock and cause a fall. At high speeds the front and rear brakes must be applied with balanced force; apply the brakes repeatedly with moderate force and avoid sudden application. Practice the above procedures for safe braking at all times.

NOTE: _____

When using engine braking for long periods, it is very important not to exceed maximum recommended r.p.m. It is also necessary to open the throttle occasionally because the engine relies on the fuel for internal cooling.

Shifting and acceleration

This model has a 4-speed transmission. The transmission allows you to control the amount of power you have available at a given speed or starting accelerating, climbing hills, etc. The use of the change pedal is shown in the illustration. To shift into NEUTRAL, repeatedly depress the change pedal to the end of its travel (you will feel a stop when you are in neutral.).

With the engine running in the neutral position, disengage the clutch (pull in clutch lever), press up on the shift lever until low gear is engaged, remove foot from shift lever, increase engine speed slightly, slowly release clutch lever while advancing throttle.

Repeat procedure for remaining gears.

Engine break-in

There is never a more important period, in the life of your motorcycle, than the period between zero and 20 hour.

For this reason we ask that you carefully read the following material. Because the engine is brand new, you must not put an excessive load on it for the first several hours of running. During the first 20 hour the various parts in the engine wear and polish themselves to the correct operating clearances. During this period prolonged full throttle operation, or any condition which might result in excessive heat of cylinder, must be avoided. However, momentary full throttle operation, under load (2 – 3 seconds maximum), does not harm the engine.

Each full throttle acceleration sequence should be followed with a substantial rest period for the engine by cruising at lower r.p.m.'s so the engine can rid itself of the temporary build up of heat.

If any abnormality is noticed during this period, ask your Yamaha dealer to check.

The method for breaking in a GTMXD is quite simple.

1. Initial Break-in:
Avoid continuous operation above half throttle. Allow a cooling off period of five to ten minutes after every hour of operation. Vary the speed of the motorcycle from time to time. Do not operate it at one set, throttle position.
2. Intermediate:
Avoid prolonged operation above 3/4 throttle. Allow the motorcycle to rev freely through the gears but do not use full throttle at any time.
3. After Break-in:
Avoid prolonged full throttle operation. Vary speeds occasionally.

PERIODIC MAINTENANCE AND MINOR REPAIR

Tool Kit

The tools provided in the owner's tool kit are sufficient for periodic maintenance and minor repair purpose, except that a torque wrench is also necessary to properly tighten nuts and bolts.

Should you desire additional service information on this model a copy of Service Manual can be purchased from any Authorized Yamaha Dealer.

CAUTION: _____

The following sections provide information for the disassembly, troubleshooting and maintenance of various components of the motorcycle. If you do not have the necessary tools and an understanding of the mechanical principles involved, please refrain from attempting repairs. The use of improper tools and/or procedures can cause major damage to the unit with resultant additional repair costs.



Periodic Maintenance

Periodic inspection, adjustment and lubrication will keep your motorcycle in the safest and most efficient condition. Safety is an obligation of the motorcycle owner.

The most important points of motorcycle inspection, adjustment and lubrication are explained below; if the owner is not familiar with motorcycle service, this work should be done by a Yamaha dealer.

LUBRICATION INTERVALS

Page	Item	Remarks	Type	Initial (hour)				Thereafter every (hour)		
				10	20	40	80	40	80	160
20, 21	Transmission oil changed	Warm engine before draining	No. 1	☆	○	○		☆	○	
34~36	Drive chain	Lube/Adjust as required	No. 2	See service notes						
34~36	Drive chain	Remove/Clean/Lube/Adjust	No. 2			○		○		
36	Control cables	All-apply thoroughly	No. 2			○	○		○	
37	Throttle grip and housing	Light application	No. 4				○		○	
—	Rear arm pivot shaft	Apply grease fully	No. 3			○		○		
—	Brake pedal shaft	Light application	No. 4			○			○	
—	Change pedal shaft	Light application	No. 4			○			○	
—	Stand shaft pivot(s)	Light application	No. 4			○			○	
Dealer	Front forks	Drain completely	No. 7		☆		○	☆	○	
Dealer	Steering ball races	Inspect thoroughly/Pack	No. 5				○		☆	○
Dealer	Point cam lubrication wick	Very light application	No. 6			○				○
Dealer	Wheel bearings	Do not over-pack	No. 5				○	☆	○	

☆ indicates check items.

Recommended lubricant type

1. Use Yamalube 4-cycle oil, or SAE 10W/30 type "SE" motor oil.
2. 1) Use YAMAHA CHAIN/CABLE LUBE.
2) Use SAE 10W/30 type "SE" motor oil. (If desired, specialty type lubricants of quality manufacture may be used.)
3. Use standard chassis lube grease.
4. Use lithium base grease.

5. Medium-weight wheel bearing grease of quality manufacture—preferably waterproof.
6. Light-weight machine oil.
7. Use Yamaha fork oil.

NOTE: _____

Drive chain must be lubricated every 0.5~1.0 hour. If unit is subjected to extremely hard use chain must be inspected frequently and serviced as required.

Periodic Maintenance Intervals

Page	Item	Remarks	Initial (hour)				Thereafter every (hour)	
			10	20	40	80	40	80
32, 33	Brake system (complete)	Check/ Adjust as required—repair as required		○	○		○	
31	Clutch	Check/ Adjust as required		○	○		○	
22, 23	Spark plug(s)	Inspect/Clean or replace as required	○	○	○		○	
—	Wheels and tires	Pressure/Spoke—tension/Runout	○	○	○		○	
—	Fittings and fasteners	Tighten before each trip and/or	○	○	○		○	
34~36	Drive chain	Tension/Alignment No. 1	○	○	○		○	
24	Air filter	Wet type—clean/Replace as required No. 2			○		○	
30	Fuel petcock(s)	Clean/Flush tank as required	○		○		○	
Dealer	Ignition timing	Adjust/Clean or replace parts as required		○	○	○		○
25~28	Carburetor adjustment	Check operation/Timings		○	○	○		○
Dealer	Carburetor overhaul	Clean/ Repair as required/Refit/Adjust						160
Dealer	Cylinder compression	Preventive maintenance check		○	○	○		○
Dealer	Decarbonize engine	Includes exhaust system			○			○

SERVICE NOTES:

- No. 1. **DRIVE CHAIN:** In addition to tension and alignment, chain must be lubricated every 0.5 ~ 1.0 hour. If unit is subjected to extremely hard usage and wet weather riding, chain must be checked constantly. See "Lubrication Intervals" for additional details.
- No. 2. **AIR FILTER:** Remove and clean filter at least once per 3~5 meet or every 20~40 hour.

Torque specifications

The list below covers those stud bolt sizes with standard I.S.O. pitch threads. Torque specifications for components with thread pitches other than standard are given within the applicable chapter.

Torque specifications call for dry, clean threads. Components such as the cylinder

or cylinder head should be at room temperature prior to torquing. A cylinder head or any other item with several fasteners should be torqued down in a crisscross pattern in successive stages until torque specification is reached. The method is similar to installing an automobile wheel and will avoid warping the component.

A (NUT)	B (BOLT)	TORQUE SPECIFICATION		
		m-kg	ft-lb	in-lb
10 mm	6 mm	1.0	7.2	85
12 mm	8 mm	2.0	15	175
14 mm	10 mm	3.5 – 4.0	25 – 29	300 – 350
17 mm	12 mm	4.0 – 4.5	29 – 33	350 – 400
19 mm	14 mm	4.5 – 5.0	33 – 36	400 – 440
22 mm	16 mm	5.5 – 6.5	41 – 49	480 – 570
24 mm	18 mm	5.8 – 7.0	42 – 50	500 – 600
27 mm	20 mm	7.0 – 8.3	50 – 60	600 – 700
SPARK PLUG		2.5 – 3.0	18 – 22	220 – 260

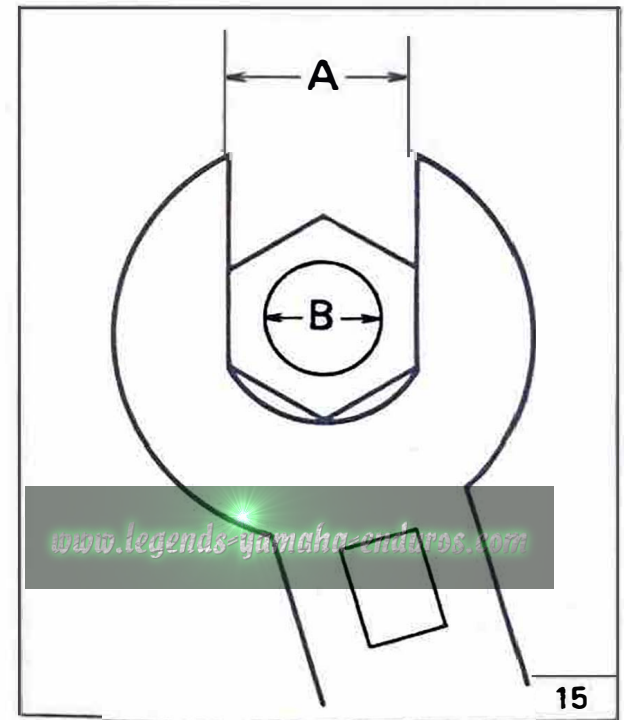

Engine oil

Use the engine oils in the following list. We recommend Yamalube 2-cycle oil (available at most Yamaha dealers) but, if other oils are used, select from the following list which is given in order of preference.

1. 2-stroke engine oil labelled "BIA certified for service TC-W".
2. SAE 30 weight, detergent type automobile engine oil with an "SE" rating. This last oil should be used only as an emergency measure when 2-stroke oils are not available.

NOTE: _____

Oil viscosity increases in very cold weather (where the normal temperature is below 0°C, 32°F) and oil does not circulate as well. In such areas, consult your Yamaha dealer.

Oil tank capacity: 0.7 lit (0.74 u.s. qt)



16
1. Refill if level shows

Transmission oil

The only servicing for you to do is to check and fill the transmission lubricating oil.

To check the level, warm the engine up for several minutes, screw the transmission oil filter cap out and then just rest the dip stick in the hole.

NOTE: _____

When checking transmission oil level with the dip stick, be sure the machine is positioned straight up and on both wheels.

Recommended oil:

Yamalube 4-cycle oil or SAE 10W/30 motor oil, type "SE" 500cc (0.53 u.s. qt.)

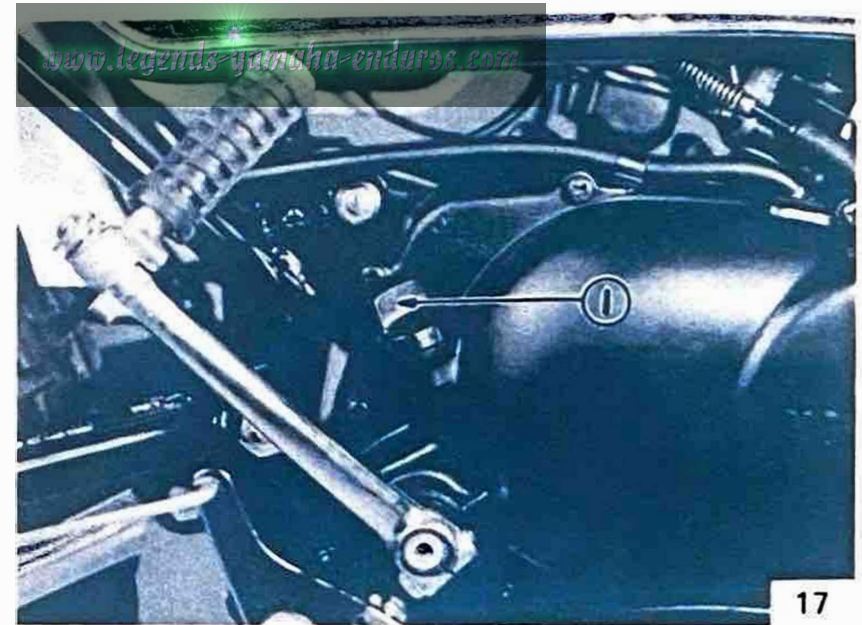

17

1. Transmission oil filler cap

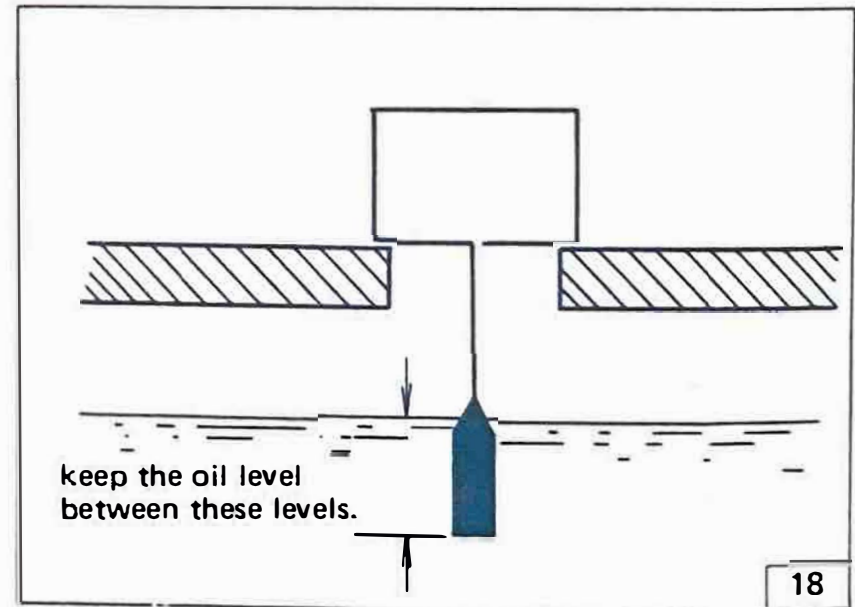

18

The dip stick has a Minimum and a Maximum mark, and the oil level should be between the two. If the level is lower, then add sufficient oil to raise it to the proper level.

During the break-in period, you should replace the gear oil 30 days after the date of purchase or thereafter 80 hour. The transmission should be drained and refilled approximately every 80 hour. On the bottom of the engine there is a drain plug. Remove it and drain all the transmission oil out.

Reinstall the drain plug (make sure it is tight). Add oil through the dip stick hole.

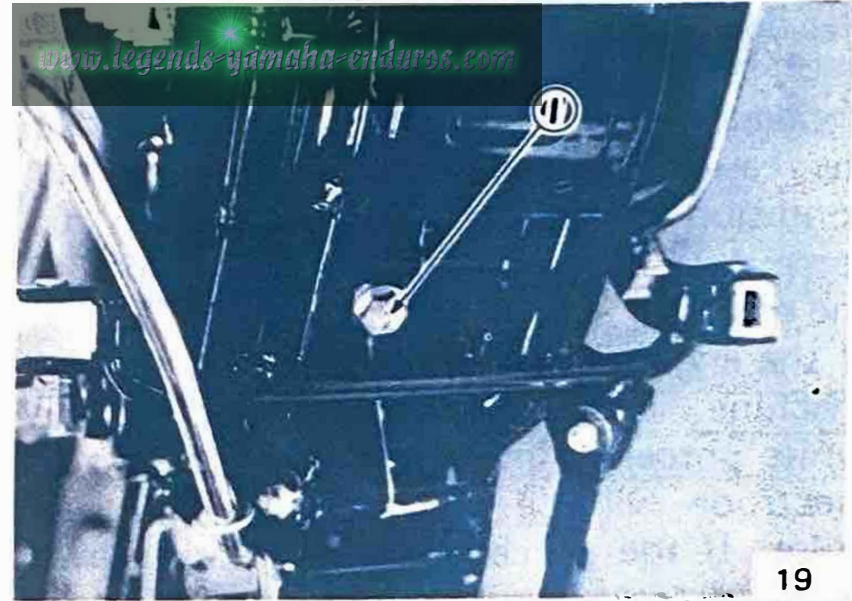

19

1. Drain plug

Spark plug inspection

The spark plug is one of the most important of the engine components and is the easiest to inspect. By examining the condition of the spark plug we can, to some extent, determine the condition of the engine.

If the engine is operating correctly, and the machine is being ridden correctly, the white porcelain insulator around the center electrode will be a medium to light tan color. If the porcelain is very dark brown or black color and the firing end is wet with oil or sooty, the spark plug may be too "cold". A "hotter" spark plug may be required. This situation is common during engine break-in. If the insulator is glazed and very light or white in color, or if the electrodes show signs of melting, a "colder" spark plug may be required.

If spark plug appearance indicates a performance problem, ask a Yamaha dealer to investigate the situation. Do not change the spark plug type without consulting with your dealer. You should, however, periodically remove and inspect the spark plug because heat and deposits will cause any spark plug to slowly break-down and erode. If electrode erosion becomes excessive, or if carbon and other deposits are excessive, you should replace the spark plug with one of the proper type.

Standard spark plug: NGK B-7HS.

CAUTION: _____

Spark plugs are produced in several different thread lengths. The thread length (reach) is the distance from the spark plug gasket seat to the end of the threaded portion. If the reach is too long, overheating and engine damage may result.

If the reach is too short, spark plug fouling and poor performance may result; also, carbon will form on the exposed threads resulting in combustion chamber hot spots and thread damage. Always use a spark plug with the proper reach.

Spark plug reach: 12.7 mm (1/2 in)

Before installing any spark plug, measure the electrode gap with a wire thickness gauge and adjust to specifications.

**Spark plug gap:
0.5 – 0.6 mm (0.020 – 0.024 in)**

When installing the plug, always clean the gasket surface and use a new gasket. Wipe off any grime from the threads and torque the spark plug properly.

**Spark plug torque:
2.5 m·kg (18 ft·lb)**

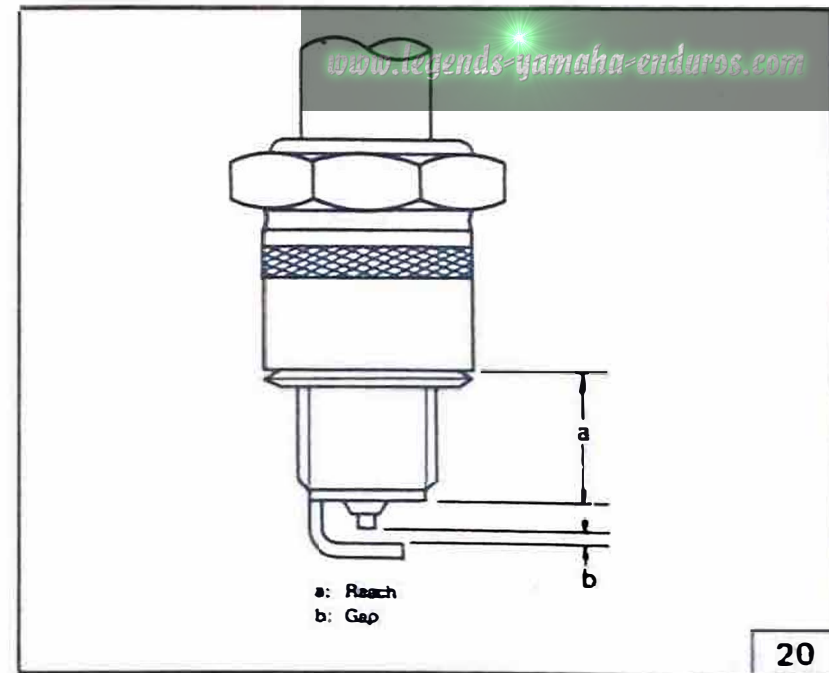

Cleaning the air filter element

The air filter protects the engine from dirt which can enter with the intake air and cause rapid engine wear. This dirt is filtered from the air by the air filter element. This model uses a cartridge type air filter element which consists of foam rubber moistened with oil. When this filter element becomes dirty it should be cleaned with solvent and reoiled.

Cleaning method

1. Remove the oil tank mounting bolt and then the tank. Remove the air filter case cap fitting screw and then the cap.

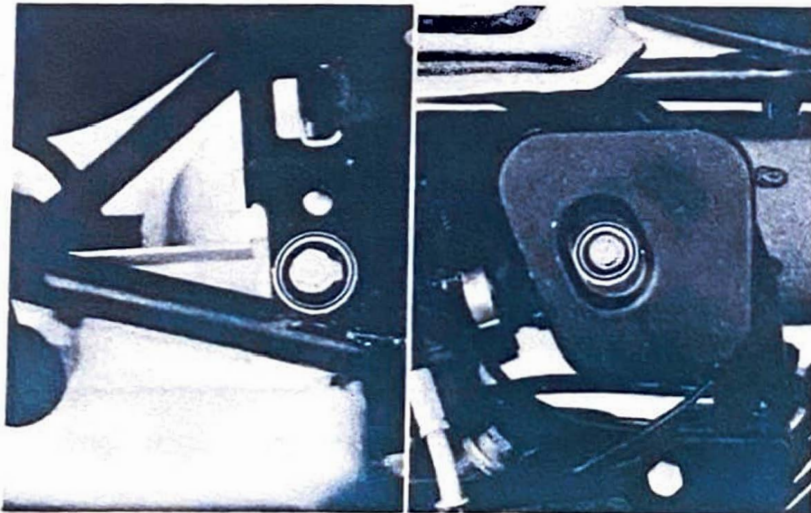

2. Remove the air filter element from its case, remove element from core and clean with solvent. After cleaning, remove the remaining solvent by squeezing the foam rubber.
3. Then apply 30 wt motor oil to the entire surface and squeeze out the excess oil. Foam should be wet but not dripping.

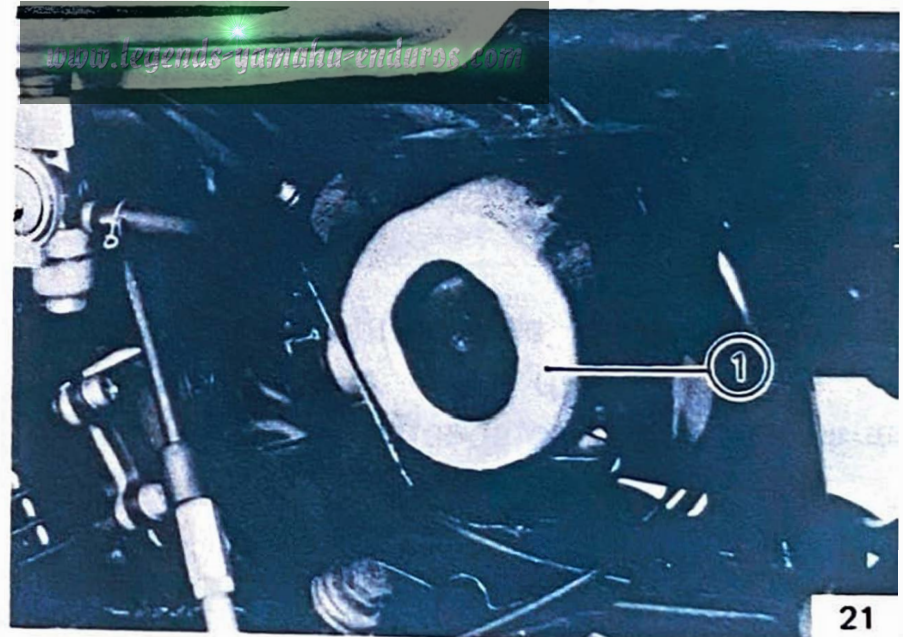

21
1 Air filter element

3. When installing the air filter element in its case, be sure its sealing surface matches perfectly the sealing surface of the case so there is not air leakage.
4. The air filter element should be cleaned once a month or every 20~40 hour. It should be cleaned every ten hours or more often if the machine is operated in extremely dusty areas.

NOTE: _____

The engine should never be run without the air cleaner element installed; overheating and piston damage may result.

Carburetor adjustment

The carburetor is a vital part of the engine and requires very sophisticated adjustment. Most adjusting should be left to a Yamaha dealer who has the professional knowledge and experience to do so. However, the following three points may be serviced by the owner as part of his usual maintenance routine.

1. Idle mixture adjustment
2. Idling speed adjustment
3. Throttle cable play adjustment

NOTE: _____

The carburetor was set at the Yamaha factory after many tests. If the setting are disturbed without having technical knowledge, poor engine performance and damage may result.

Idle mixture adjustment

The idle mixture adjustment controls the amount of mixture to the engine at low r.p.m. The idle mixture also insures smooth transition to the main circuit with no power loss or misfire; so it does affect midrange performance.

Make this adjustment as described below: Tighten the pilot air screw until it lightly touches the seat; then back the screw out the specified number of turns. This should be done with the engine stopped.

Standard pilot air screw setting (number of turns out): 1-1/2.

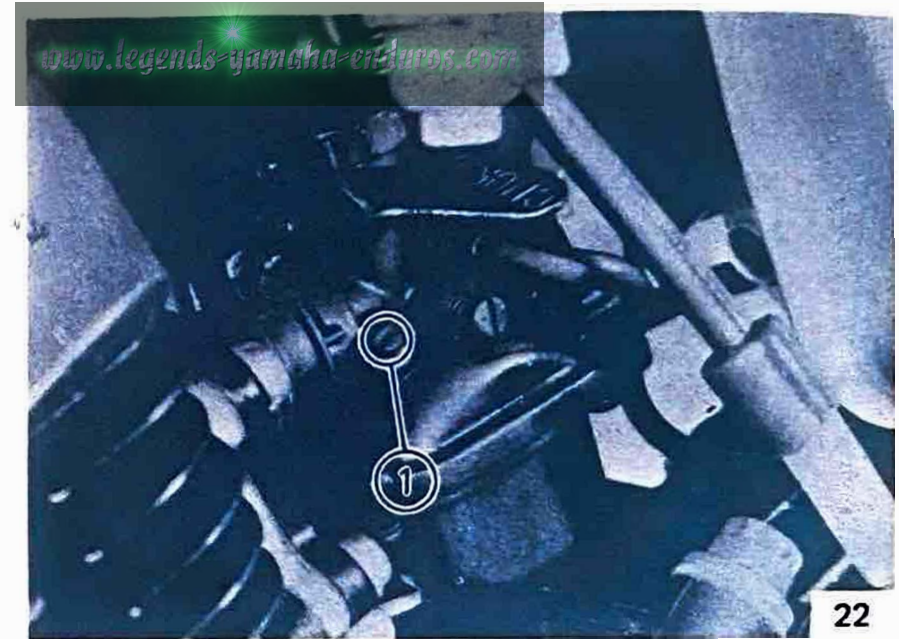

22

1. Pilot air screw

Idling rpm adjustment

Start the engine and warm it up for a few minutes. The warm up is complete when the engine responds quickly without dying. Normally 1 to 2 minutes is required; 2 to 3 minutes in cold weather. Turning the throttle stop screw counterclockwise lowers the engine speed. One clockwise turn from the engine stall position is considered to be the specified idling position.

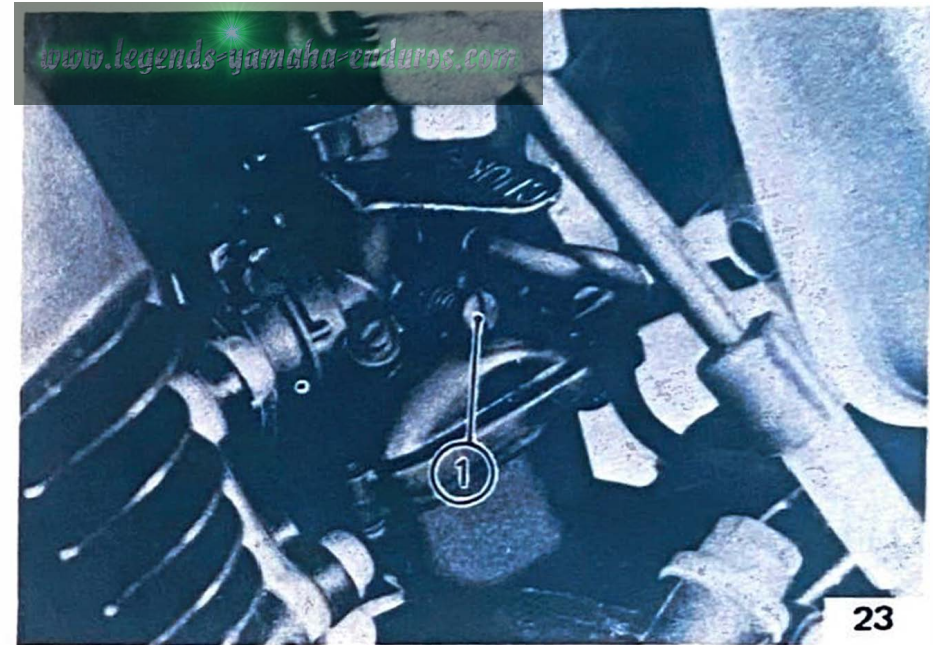

23
1. Throttle stop screw

Carburetor inspection

In addition to the above adjustment, check the following periodically:

1. Are the carburetor holding bolts loose?
2. Is the air vent pipe in the correct position?
3. Is the overflow pipe connected properly?
4. Is the mixing chamber top loose?

Inspection and adjustment of play in throttle cable 2

A throttle cable should always have a little play in it. If too tight, a sharp turn may cause the engine speed to increase. On the other hand, if the throttle valve does not open fully when the throttle grip is turned fully, full speed is not possible. Adjust as described below.

NOTE: _____

Before adjusting the play in throttle cable 2, adjust the engine idling speed and make sure the mixing chamber top is tight.

1. Move the rubber cover of the mixing chamber top to expose the wire adjuster.
2. Hold the outer cable near top of carburetor and down to check the play.
3. Loosen locknut and turn the wire adjuster in or out to achieve 0.04 in (1 mm) of play. Be sure to tighten the locknut.

Inspection and adjustment of play in throttle cable 1

The following explains the adjustment of throttle cable 1 (see illustration).

NOTE: _____

Adjust the play in both throttle cables; if only one is adjusted, trouble may occur. Check the outer cable play at the wire guide of the throttle grip assembly. The play should be 0.5 – 1.0 mm (0.02 – 0.04 in) loosen the lock nut and turn the wire adjuster to make the necessary adjustment. After adjusting, be sure to tighten the locknut properly.

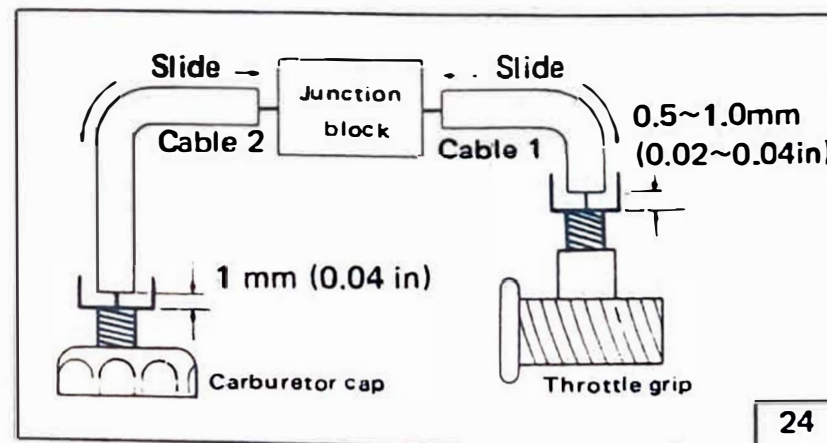

Autolube pump cable adjustment

Close the throttle grip completely, then twist it open until all cable slack is removed, but stop before the slides start to lift.

Adjust the pump cable so the mark on the pump pulley lines up with the "adjust pulley guide pin". The Autolube cable adjuster is located at the bottom end of the cable, screwed into the top of the right case cover.

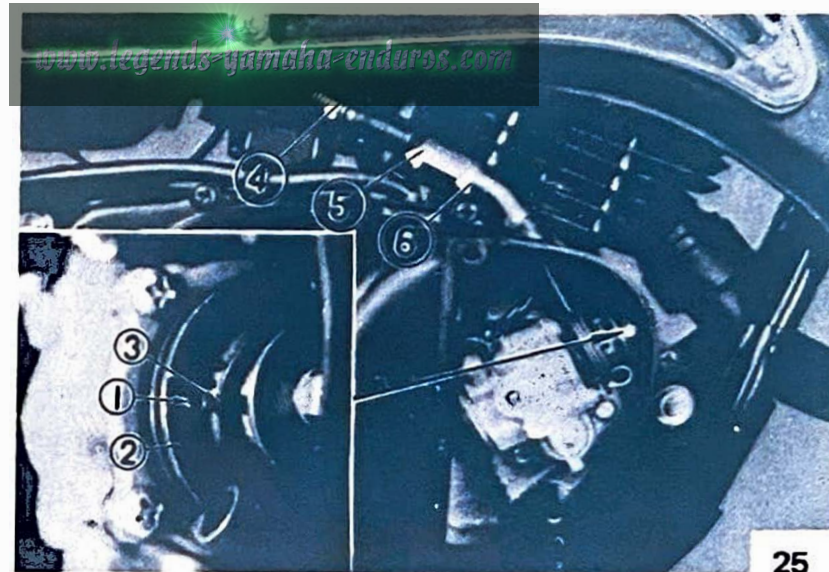

- | | |
|------------------|---------------------|
| 1. Mark (o) | 4. Pump cable |
| 2. Adjust pulley | 5. Adjustor |
| 3. Pin | 6. Adjuster locknut |

Bleeding the Autolube pump

If the pump runs out of oil, the pump must be bled to release air trapped in the pump.

1. Remove the pump cover and the bleed screw.
2. Start the engine and run at idling speed.
3. Pull the oil pump wire as much as possible, and continue to run the engine until all air bubbles disappear from the oil flowing out from the bleeder hole.
4. Reinstall the bleed screw and the pump cover.

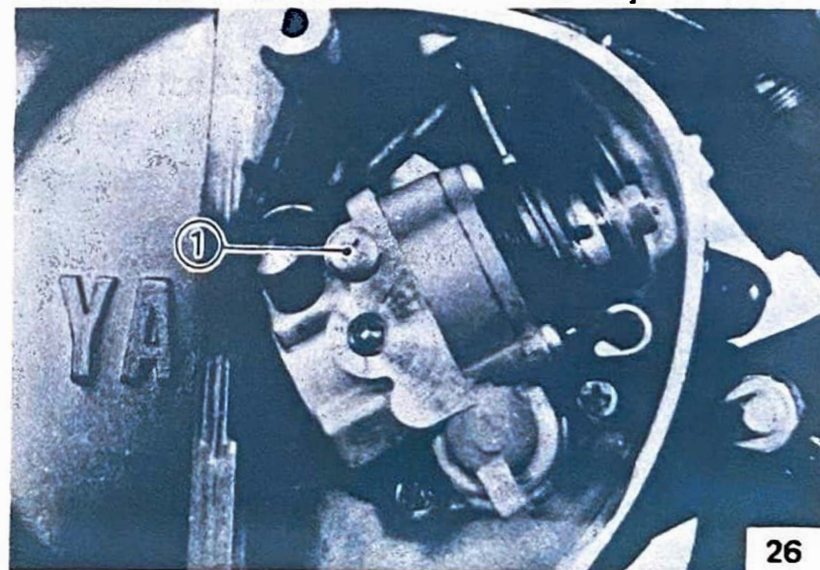

1. Bleed screw

Fuel petcock inspection and cleaning

The fuel petcock has a built-in filter to remove any particles before they reach the carburetor. If the filter becomes blocked, the fuel cannot enter the carburetor. To prevent this, inspection and cleaning should be done at recommended intervals.

1. First, turn the petcock lever to the "OFF" position; then remove the filter cup and clean the bottom of the cup with solvent.
2. After removing the filter cup, remove and clean the filter screen. At the same time, you should examine the condition of the filter gasket. Replace if damaged.
3. When reassembling, be careful not to clamp the filter cup too tightly as this may cause the filter gasket to become unseated resulting in fuel leakage.

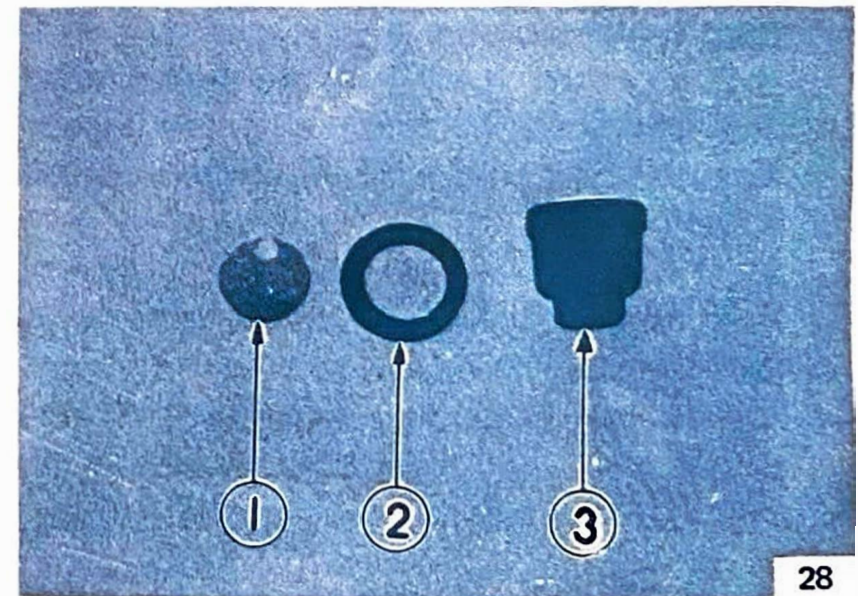
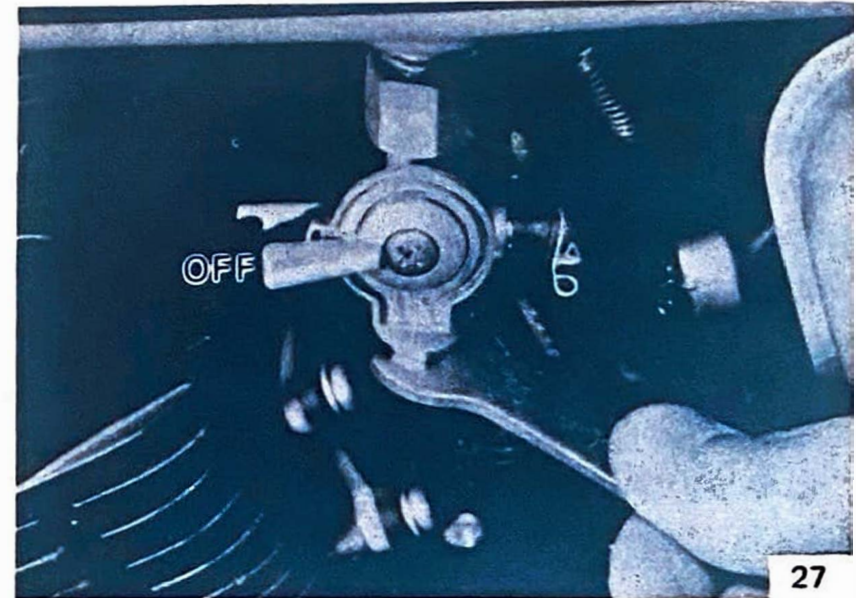

1. Filter screen 2. Filter gasket 3. Filter cup

Clutch adjustment

The clutch requires two adjustments; (1) adjusting the play of the clutch cable, and (2) adjusting the play in the clutch push screw. Normally, only the play of the cable need be adjusted; leave adjustment of the push screw to the dealer. Loosen the locknut and make the adjustment by turning the adjustor until the clearance between the front of the clutch lever and the lever holder is between 2 – 3 mm (1/16 – 1/8 in), and tighten the locknut.

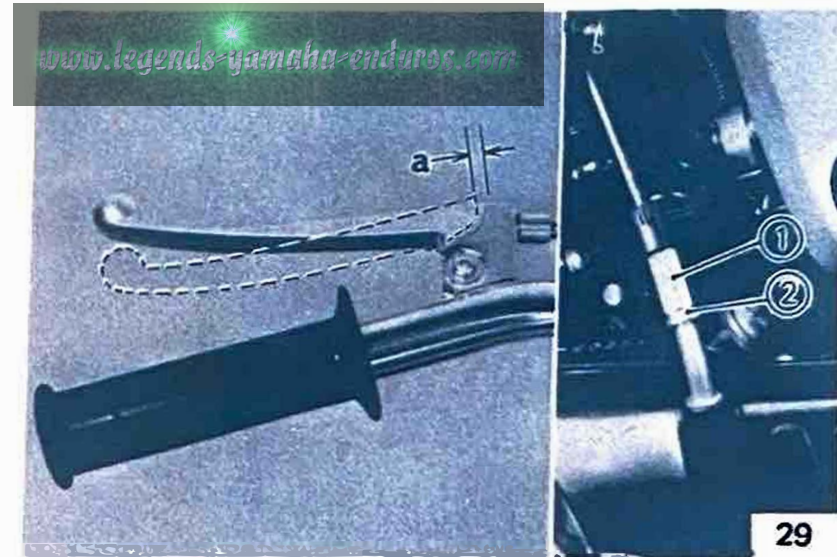

a. 2 – 3 mm (1/16 – 1/8 in)

1. Adjustor

2. Locknut

Front brake adjustment

Front brake lever free play should be 5 – 8 mm (0.2 – 0.3 in). To adjust the free play, loosen the lock nut on the front brake cable end and turn the adjustor in or out. After adjusting, be sure the locknut is tightened firmly.

When it is impossible to make an adjustment at the brake lever, ask a Yamaha dealer for adjustment at the brake shoe plate.

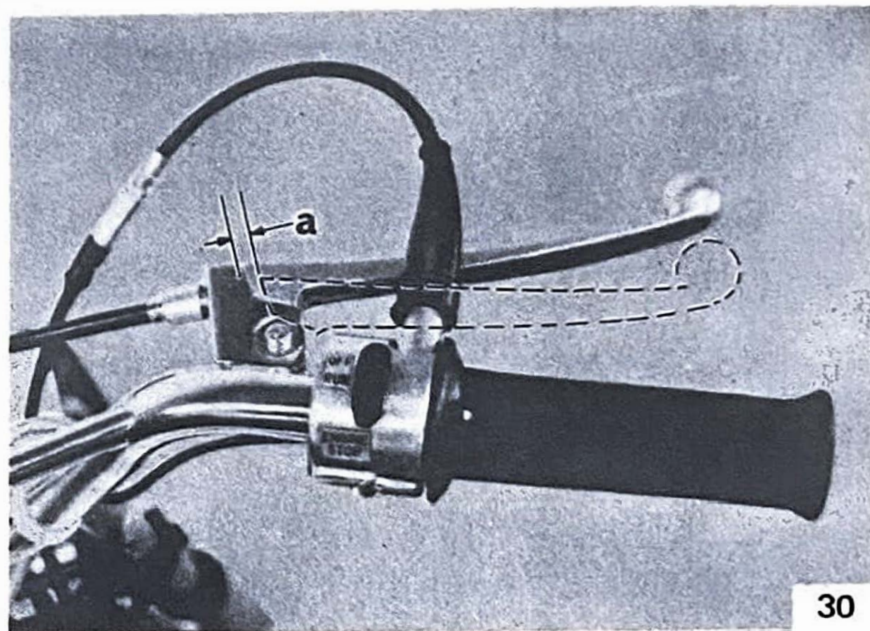

a. 5 – 8 mm (0.2 – 0.3 in)

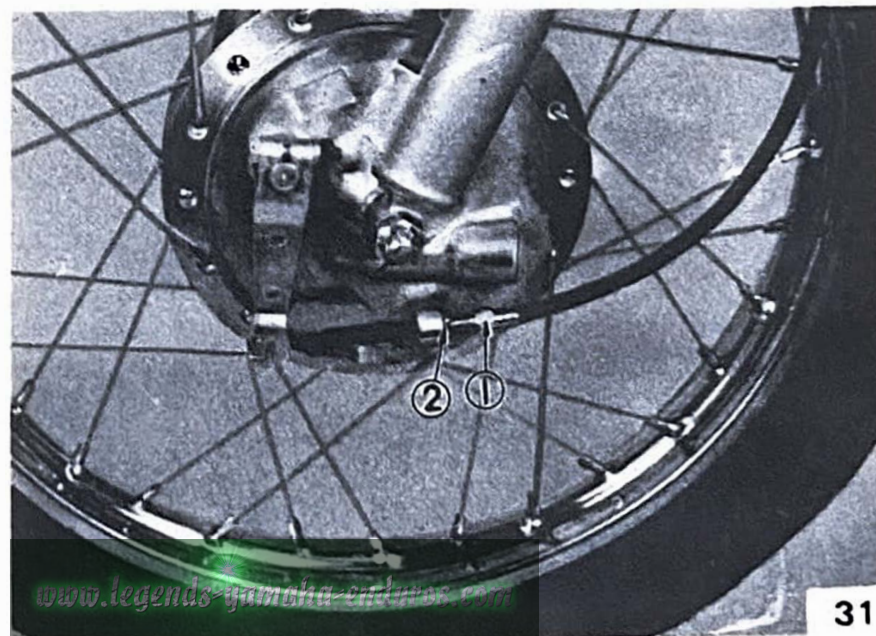

1. Adjustor 2. Locknut

Rear brake adjustment

The rear brake should be adjusted so the end of the brake pedal moves 20 – 30 mm (0.8 – 1.2 in). To adjust, turn the adjustor on the brake rod clockwise to reduce play; turn the adjustor counterclockwise to increase play.

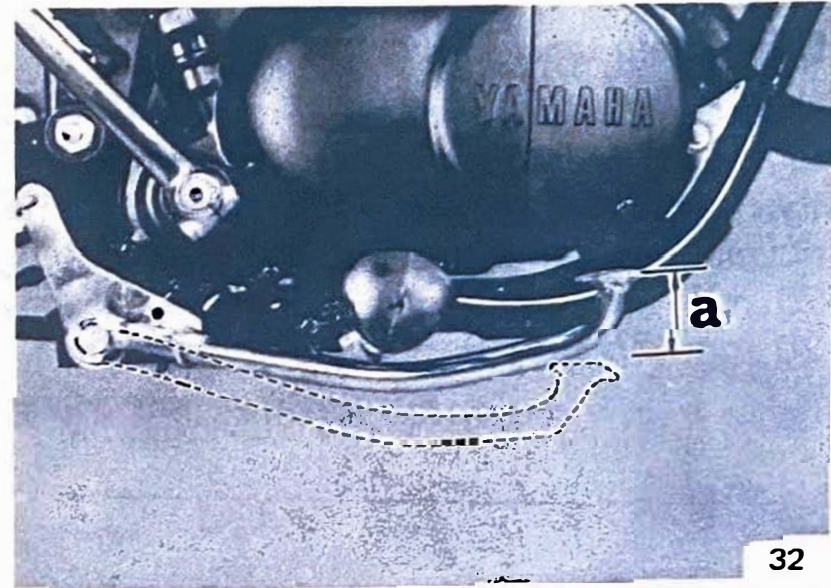

a. 20 – 30 mm (0.8 – 1.2 in)

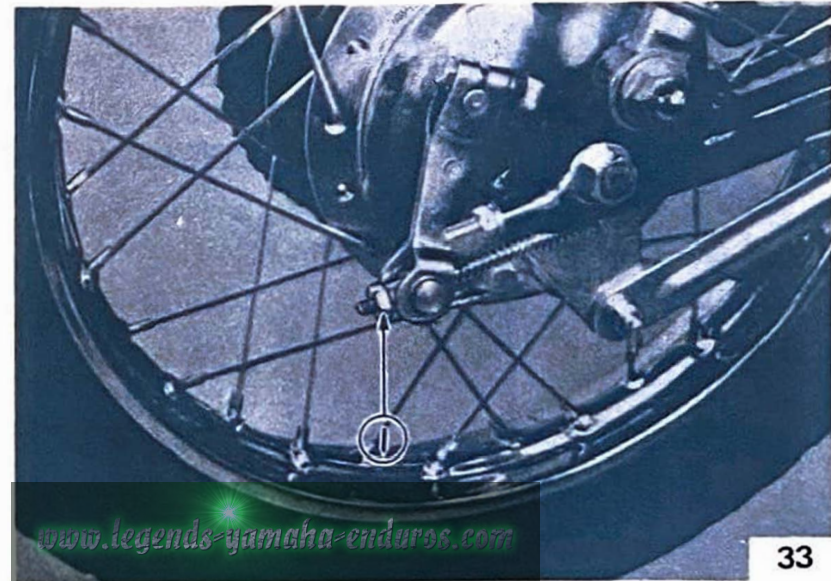

1. Adjustor

Drive chain tension check

Inspect the drive chain with both tires touching the ground. Check the tension at the position shown in the illustration. The normal vertical deflection is approximately 20 mm (3/4 in). If the deflection exceeds 20 mm (3/4 in) adjust the chain tension.

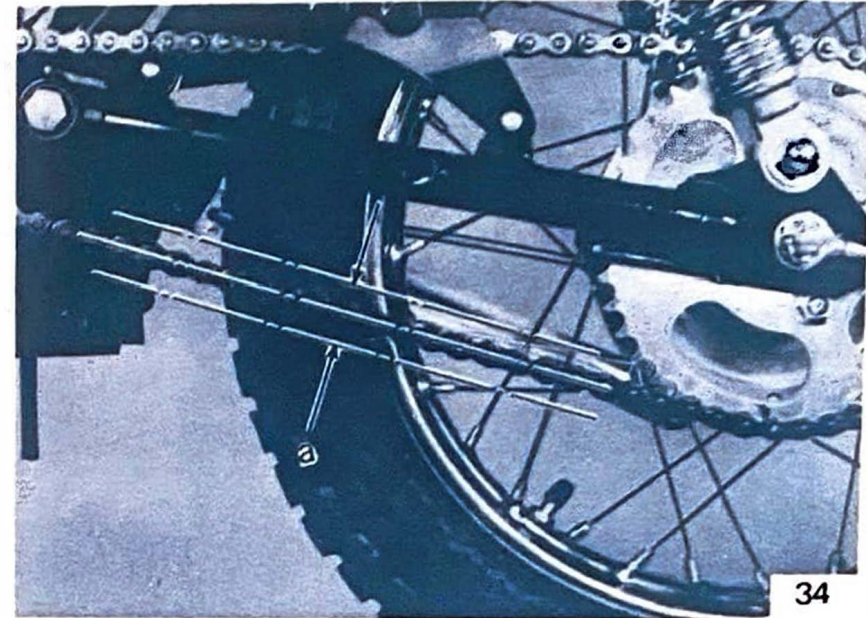

a. 20 mm (3/4 in)

Drive chain tension adjustment

1. Loosen the rear brake rod adjust nut.
2. Remove the cotter pin of the rear wheel axle nut with pliers.
3. Loosen the rear wheel axle nut.



1. Cotter pin
2. Axle nut

3. Adjust nut
4. Marks for alignment

4. To tighten chain turn chain puller adjust nuts clockwise. To loosen chain turn adjust nuts counterclockwise and push wheel forward. Turn each nut exactly the same amount to maintain correct axle alignment (There are marks on each side of rear arm and on each chain puller; use them to check for proper alignment).

NOTE: _____

Before adjusting, rotate rear wheel through several revolutions and check tension several times to find the tightest point. Adjust chain tension with rear wheel in this "tight chain" position.

5. After adjusting, be sure to tighten the rear wheel axle nut.
6. Also tighten the adjust nuts against the rear arm (About 1/4 turn each).
7. Insert the cotter pin into the rear wheel axle nut and bend the cotter pin end as shown in the illustration (if the nut notch and the cotter pin hole do not match, tighten the nut slightly to match).

8. In the final step, adjust the play in the brake pedal.

NOTE: _____

Excessive chain tension will overload the engine and other vital parts; keep the tension within the specified limits. Also, replace the rear axle cotter pin with a new one.

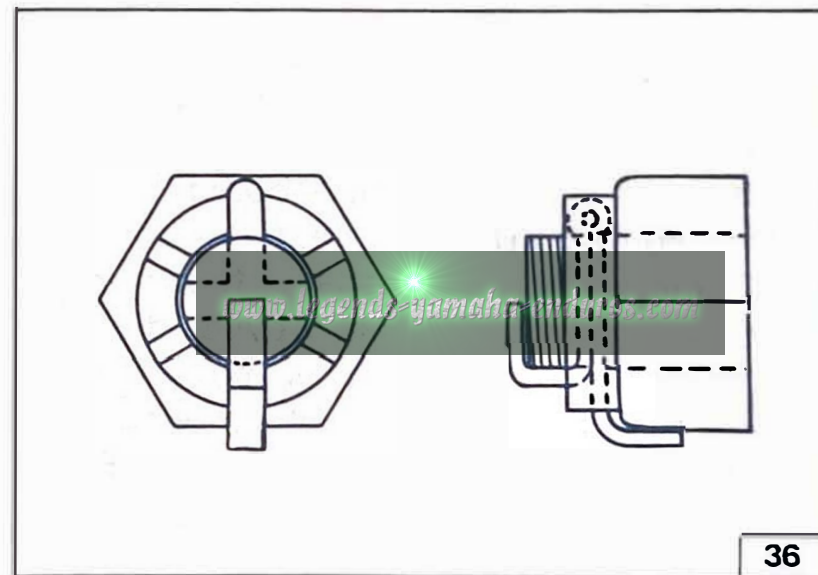

Drive chain lubrication

The chain consists of many parts which work against each other. If the chain is not maintained properly, it will wear out rapidly.

Without lubrication the chain could wear out within 1 hour: therefore, form the habit of periodically servicing the chain. This service is especially necessary when driving in dusty conditions.

1. Use any of the many brands of spray type chain lubricant. First, remove dirt and mud from the chain with a brush or cloth and then spray the lubricant between both rows of side plates and on all center rollers. This should be performed every 0.5~1.0 hour.
2. To clean the entire chain, first remove the chain from the motorcycle, dip it in solvent and clean out as much dirt as possible. Then take the chain out of the solvent and dry it. After drying, lubricant the chain to prevent the formation of rust.

Cable inspection and lubrication

1. Damage to the outer housing of the various cables, may cause corrosion and often free movement will be obstructed. An unsafe condition may result so replace as soon as possible.
2. If the inner cables do not operate smoothly, lubricate or ask your Yamaha dealer to replace them.

Recommended lubricant:

YAMAHA CHAIN/CABLE LUBE

Throttle cable and grip lubrication

The throttle twist grip assembly should be greased at the time that the cable is lubricated, since the grip must be removed to get at the end of the throttle cable. Two screws clamp the throttle housing to the handlebar. Once these two are removed, the end of the cable can be held high to pour in several drops of lubricant. With the throttle grip disassembled coat the metal surfaces of the grip assembly with a suitable all-purpose grease to cut down friction. (See lubrication chart)

A special cable lubricator attachment is available from your Yamaha dealer.

Lubrication of levers, pedals, etc.

1. Lubricate the pivoting parts of the brake and clutch levers with motor oil (10W/30).
2. Lubricate the shaft of the brake pedal with lithium soap grease.

Steering inspection

Periodically inspect the condition of the steering. Worn out or loose steering bearings may be dangerous.

Place a block under the engine to raise the front wheel of the motorcycle off the ground; then hold the lower end of the front fork and try to move forward and backward. If any free play can be felt, ask a Yamaha dealer to inspect and adjust.

Inspection is easier if the front wheel is removed. Ask a dealer to lubricate the steering bearings every 160 hour of operation (move often in cases of off-road operation).

Front and Rear wheel alignment

The only front and rear wheel service that should be performed by the owner is air pressure inspection, tire wear inspection, tire and tube replacement, brake lining inspection, etc. Brake lining replacement, tightening spokes, hub replacement, etc., should be left to a Yamaha service technician.



Front wheel removal

1. Remove brake cable: Loosen all cable adjust screws and remove cable from handle lever holder. Then remove cable from cam lever at front brake shoe plate.
2. Remove cotter pin from front wheel axle and remove axle nut.
3. Loosen pinch bolt at other end of axle.
4. Elevate the front wheel by placing a suitable stand under the engine.
5. Turn and pull out the front wheel axle; the wheel assembly can now be removed.

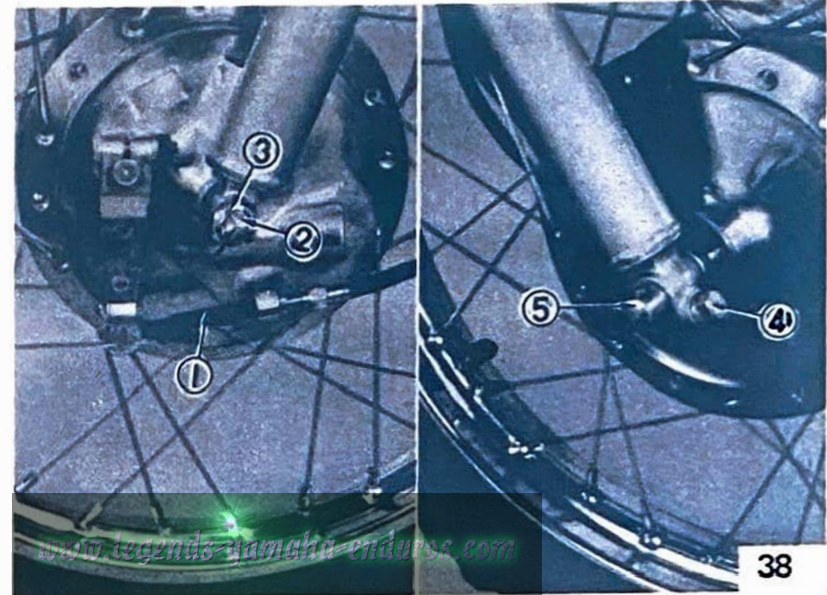

1. Front brake cable
2. Cotter pin
3. Axle nut

4. Pinch bolt
5. Front wheel axle

Front wheel installation

When installing front wheel, reverse the removal procedure taking care of the following points:

1. Check for proper engagement of the boss on the outer fork tube with the locating slot on the brake shoe plate.
2. Always secure the front wheel axle as follows:
 - a) Torque the front axle nut.

Axle nut torque:

6.0 m-kg (43 ft-lb)

- b) Install a new cotter pin; discard old pin.
- c) Torque front axle pinch bolt.

Pinch bolt torque:

2.0 m-kg (14 ft-lb)

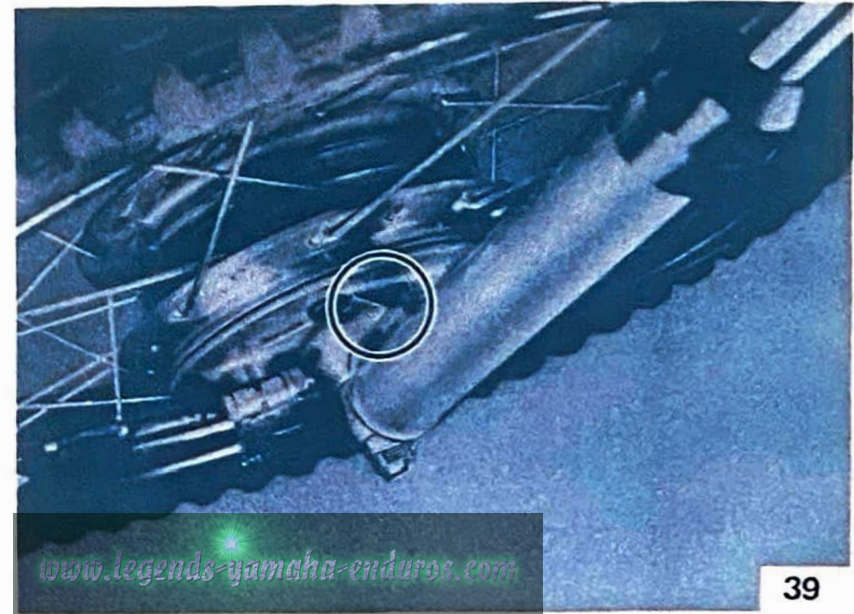

Removing the rear wheel

1. Remove the tension bar and the brake rod from the brake shoe plate. The tension bar can be removed by removing the cotter pin and nut from the tension bar bolt. The brake rod can be removed by loosening the adjust nut.
2. Remove the cotter pin and rear wheel axle nut.
3. If the rear wheel axle is pulled out, the wheel assembly, the shoe plate, the collar and chain pullers can be removed from the motorcycle.

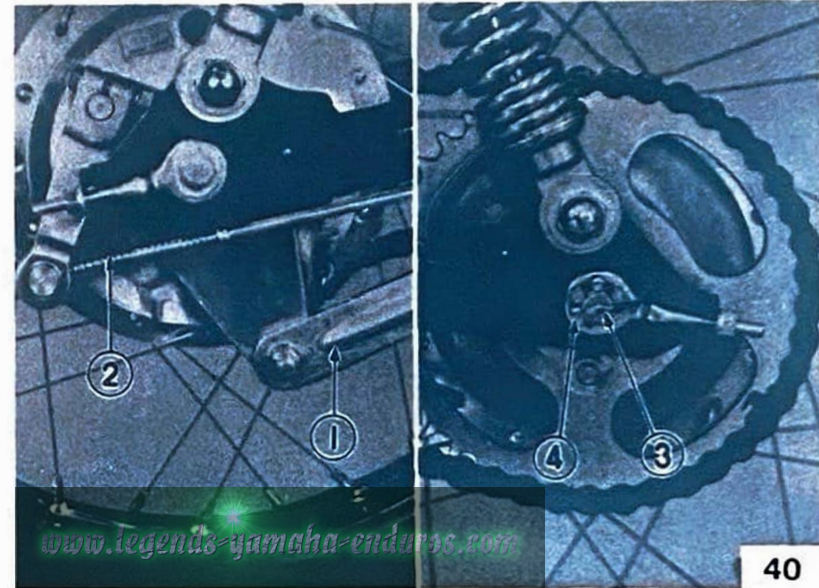

1. Tension bar

2. Brake rod

3. Cotter pin

4. Axle nut

Rear wheel installation

The rear wheel can be reassembled by reversing the disassembly procedure. Take care of the following points.

1. When connecting the chain, make certain closed end of master link clip is facing direction of rotation.
2. Be sure to adjust the tension of the chain. Adjust with both wheels on the ground. The chain deflection at the center (between drive sprocket and rear sprocket) should be adjusted to 20mm (3/4 in.)
3. Position the chain pullers at corresponding marks on the rear arms to maintain rear axle alignment.
4. Torque the rear axle nut.

Axle nut torque:

6.0 m-kg (43 ft-lb)

5. Adjust the brake pedal.
6. Always use a new cotter pin. Old pins should be discarded.

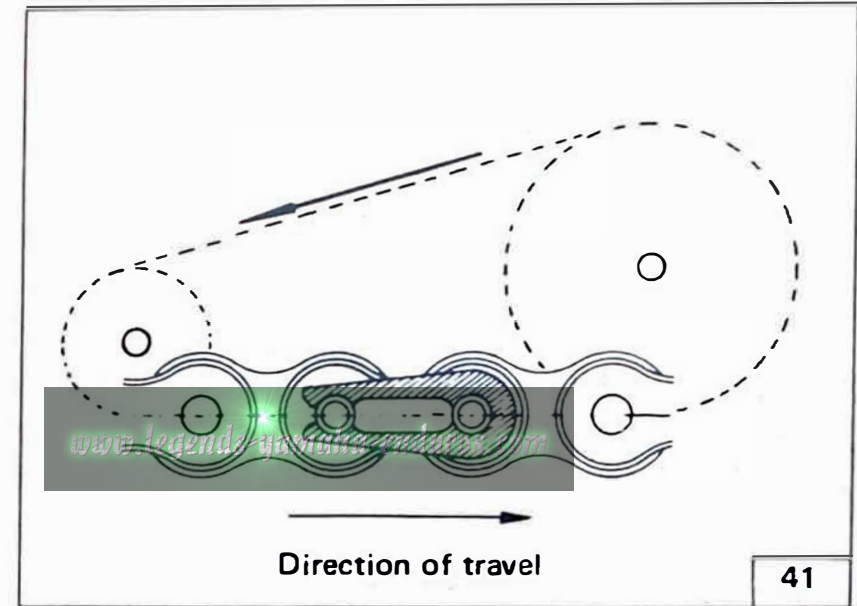

Brake shoe inspection

Measure the outside diameter of the brake shoe set with slide calipers.

If it measures less than specified, replace the shoes. Smooth out any rough shoes surface with sandpaper.

	Standard	Wear Limit
Front brake shoe diameter	110 mm (4.3 in)	105 mm (4.1 in)
Rear brake shoe diameter	110 mm (4.3 in)	105 mm (4.1 in)

Brake drum inspection

The friction between the inner surface of the brake drum and the brake lining provides the energy to stop the motorcycle. If these become damaged or if oil contacts the drum, noise may occur and brake performance will suffer. Check the inner surface of the brake drum and remove any scratches with emery cloth. Remove any oil with a cloth dipped in solvent. If damage is more extensive, have a Yamaha dealer replace the wheel hub.

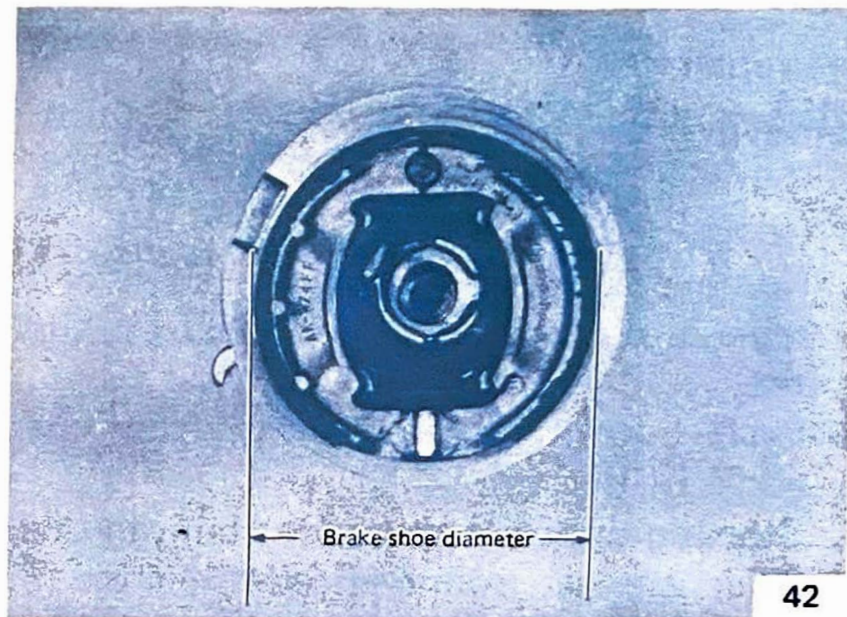

Tire repair

Removing the Tire

1. Remove the wheel from the motorcycle (see page 39, 41),
2. Remove locknut from valve stem and release as much air as possible from the tire.
3. Push both tire beads away from the edges of the rim.
4. Starting opposite the valve stem on one side, use two round-ended tire iron to work the bead off the rim.

NOTE: _____

Use a tire removal lubricant and be careful not to pinch the tube with the tire irons.

5. Remove the valve stem from its hole and remove the tube.
6. If the tire is to be changed, remove the second bead from the rim using the tire irons and tire lubricant.

Inspection

1. Use a cloth to check for nails or other sharp objects in the tire.

CAUTION: _____

Always use a cloth to avoid cutting your hand.

2. Check for faults in the side wall. If there is any fault, the tire should be replaced as a damaged tire may burst at high speed, which is extremely dangerous.
3. Inflate the tube with air and check the valve stem and the tube for damage and leakage. Replace as required. Some leaks can be patched in an emergency, but it is best to replace tube.
4. Inspect rim band and replace if damaged.

Reassembly

1. Install one tire bead on the rim using tire irons and lubricant and then install the tube.
2. Inflate tube with air to about one-third the specified pressure. Hit the outer circumference of the tire with a soft hammer to make certain the tube is not caught between tire and rim. Release air from tube.
3. Install second tire bead starting opposite the valve stem using tire irons and tire mounting lubricant.
4. Inflate tire to approximately 2.0 kg/cm² (28 psi) and then reduce pressure to specified setting.
5. Tighten the valve stem locknut.

NOTE: _____

Check the valve stem; it must be pointing directly at center of wheel hub. If angled in any direction, release air and adjust tube position.

Tire air pressure

Improper tire pressure affects the smoothness of the tire, traction, handling and the life of the tires. Always maintain the proper tire pressure.

Proper air pressure

Front	0.9 ~ 1.1 kg/cm ² (13 ~ 16 psi)
Rear	0.9 ~ 1.1 kg/cm ² (13 ~ 16 psi)

Rim and spokes

There are checks that you can perform to determine if wheel work is necessary for your dealer to do. First, check for any loose spokes. This can be checked by bracing the front end off the ground so that the front wheel can spin free. Slowly revolve the front wheel and at the same time let the metal shaft of a fairly heavy screwdriver bounce off each spoke. If all the spokes are tightened approximately the same, then the sound given off by the screwdriver hitting the spokes should sound the same.

If one spoke makes a dull flat sound, then check it for looseness. While you have the front end up in the air, you should check that the front wheel does not have too much run-out. "Run-out" is the amount the front wheel deviates from a straight line as it spins. Secure the front forks from turning, spin the front wheel, and solidly anchor some sort of a pointer about 3 mm (1/8 in) away from the side of the rim.

As the wheel spins, the distance between the pointer and the rim should not change

more than 2 mm (1/6 in) total. Any greater fluctuation means that you should have your dealer remove this rim warpage by properly adjusting the spokes.

Troubleshooting

Although Yamaha motorcycles are given a rigid inspection before shipment from the factory, trouble may occur in operation. If this happens check the motorcycle in accordance with the procedures given in the troubleshooting chart below. If repair is necessary, ask your Yamaha dealer.

The skilled technicians at your Yamaha dealer provide excellent service. For replacement parts, use only genuine Yamaha Parts. Imitation parts are similar in shape but often inferior in quality of materials and workmanship, consequently, service life is shorter and more expensive repairs may be necessitated.

Any fault in the fuel, compression or ignition systems can cause poor starting or loss of power while driving. The troubleshooting chart describes quick and easy procedures for checking these systems.

Trouble shooting

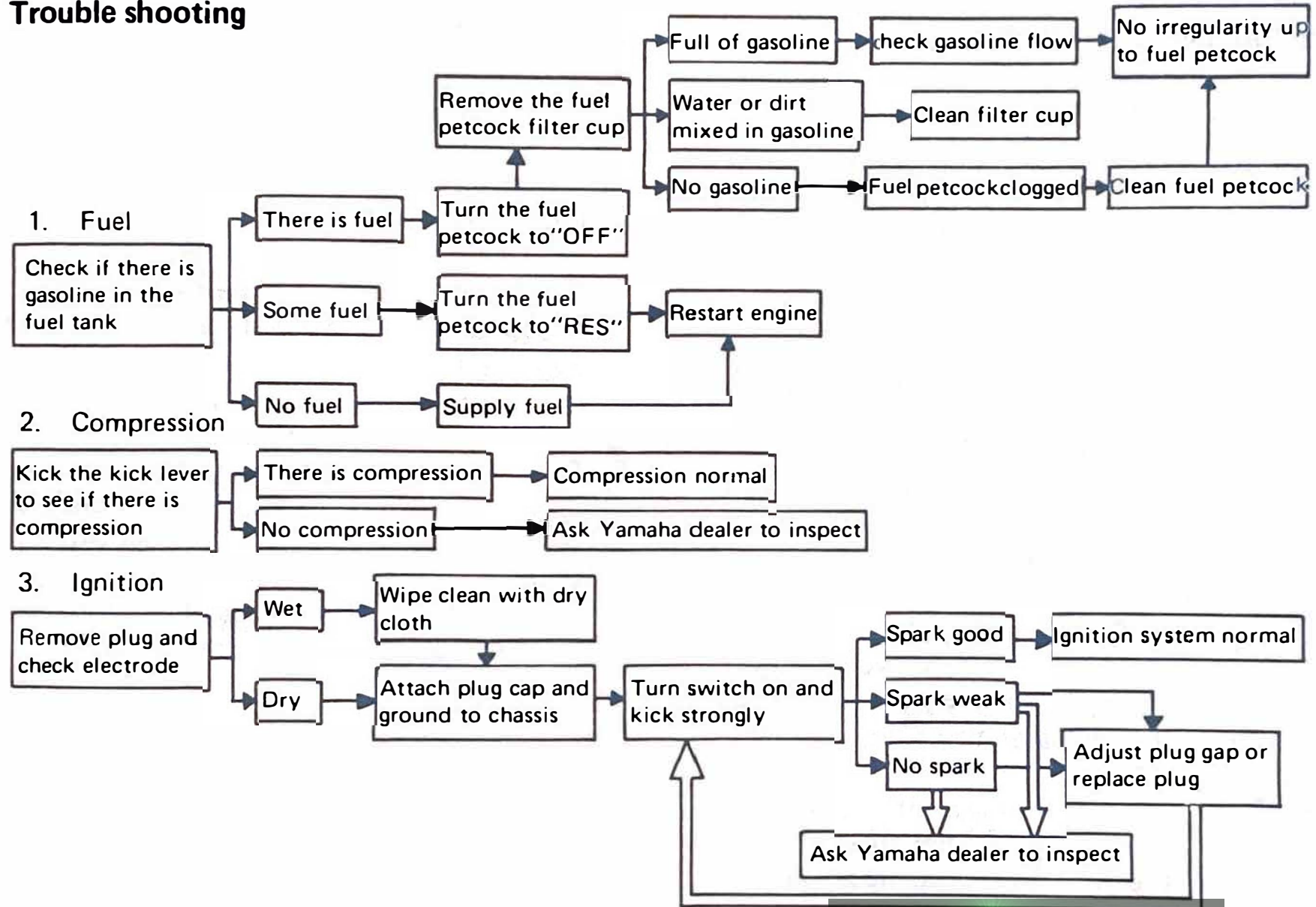

CLEANING AND STORAGE

A. CLEANING

Frequent thorough cleaning of your motorcycle will not only enhance its appearance but will improve general performance and extend the useful life of many components.

1. Before cleaning the machine:
 - a) Block off end of exhaust pipe to prevent water entry; a plastic bag and strong rubber band may be used.
 - b) Remove air cleaner or protect it from water with plastic covering.
 - c) Make sure spark plug(s), gas cap, oil tank cap, transmission oil filler cap are properly installed.
2. If engine case is excessively greasy, apply degreaser with a paint brush. Do not apply degreaser to chain, sprockets, or wheel axles.
3. Rinse dirt and degreaser off with garden hose, using only enough hose pressure to do the job. Excessive hose pressure may cause water seepage and contamination of wheel bearings, front forks, brake drums, and transmission seals. Many expensive repair bills have resulted from improper high pressure detergent applications such as those available in coin-operated car washes.
4. Once the majority of the dirt has been hosed off, wash all surfaces with warm water and mild, detergent-type soap. An old tooth brush or bottle brush is handy to reach hard-to-get-to places.
5. Rinse machine off immediately with clean water and dry all surfaces with a chamois, clean towel, or soft absorbent cloth.
6. Immediately after washing, remove excess moisture from chain and lubricate to prevent rust.
7. Chrome-plated parts such as handlebars, rims, spokes, forks, etc., may be further cleaned with automotive chrome cleaner.

8. Clean the seat with a vinyl upholstery cleaner to keep the cover pliable and glossy.
9. Automotive-type wax may be applied to all painted and chrome-plated surfaces. Avoid combination cleaner-waxes. Many contain abrasives which may mar paint or protective finish on fuel and oil tanks.
10. After finishing, start the engine immediately and allow to idel for several minutes.

B. STORAGE

Long term storage (30 days or more) of your motorcycle will require some preventive procedures to insure against deterioration. After cleaning machine thoroughly, prepare for storage as follows:

1. Drain fuel tank, fuel lines, and carburetor float bowl(s).
2. Remove empty fuel tank, pour a cup of 10W to 30W oil in tank, shake tank to coat inner surfaces thoroughly and drain off excess oil. Re-install tank.

3. Remove spark plug(s), pour about one tablespoon of 10W to 30W oil in spark plug hole(s) and re-install spark plugs. Kick engine over several times (with ignition off) to coat cylinder walls with oil.
4. Remove drive chain. Clean thoroughly with solvent and lubricate. Re-install chain or store in a plastic bag (tie to frame for safe-keeping).
5. Lubricate all control cables.
6. Block up frame to raise both wheels off ground. (Main stands can be used on machines so equipped.)
7. Tie a plastic bag over exhaust pipe outlet(s) to prevent moisture entering.
8. If storing in humid or salt-air atmosphere, coat all exposed metal surfaces with a light film of oil. Do not apply oil to rubber parts or seat cover.

NOTE: _____

Make any necessary repairs before storing the motorcycle.

Requirements for a Good Motorcyclist

1. Safety is more important than speed. Always observe traffic regulations and signs.
2. Always use quality gasoline and oil, and avoid the inconvenience of running out of gas or oil.
3. Check tire pressures before every ride.
4. Warm up the engine for about one minute before riding.
5. Shift gears gently, while momentarily closing the throttle, avoid power shifting.
6. During the break-in period, ride at the suggested speed in each gear.
7. Apply the front and the rear brake at the same time.
8. Down a long hill, use engine compression as a brake.
9. When parking, be sure to turn off and remove the ignition key, turn off the fuel petcock and lock the steering.
10. Check parts at regular intervals as described in this manual.

SPECIFICATIONS

Model		GTMXD
Dimension	Overall length	1,550 mm (61.0 in)
	Overall width	690 mm (27.2 in)
	Overall height	930 mm (36.6 in)
	Wheelbase	1,045 mm (41.1 in)
	Minimum road clearance	195 mm (7.7 in)
Weight	Net	59 kg (130 lb)
Performance	Minimum turning radius	1,500 mm (59.1 in)
	Braking distance	7.5 m at 35 km/h (24.6 ft at 22 mph)
	Climbing ability	20°
Engine	Type	Air-cooled, 2-stroke, gasoline, Torque induction
	Cylinder	Single, Forward inclined
	Displacement	72 cc (4.39 cu. in)
	Bore & Stroke	47 mm x 42 mm (1.850 in x 1.654 in)
	Compression ratio	6.8 : 1
	Starting system	Primary kick
	Ignition system	Magneto
	Gasoline tank capacity	4.8 lit (1.3 U.S.gal)
	Oil tank capacity	0.7 lit (0.74 U.S.qt)
Lubricating system	Separate lubrication (Yamaha Autolube)	

		GTMXD
	Spark plug Carburetor Air cleaner	NGK (B-7HS) x 1 (Y16P-3) x 1 Oiled, foam rubber
Transmission	Primary reduction system Primary reduction ratio Secondary reduction system Secondary reduction ratio Clutch Gear box type Gear ratio 1st 2nd 3rd 4th	Gear 68/19 (3.578) Chain 41/14 (2.928) Wet, multi-disc type Constant mesh 4 speed 39/12 (3.250) 34/17 (2.000) 30/21 (1.428) 27/24 (1.125)
Steering	Caster Trail	63° 30' 68 mm (2.7 in)
Tire size (Tire pattern)	Front Rear	2.50–15–4PR (Trials Universal tire) 2.75–14–4PR (Trials Universal tire)
Suspension system	Front Rear	Telescopic fork, Coil spring, Oil damper Swing arm, Coil spring, Oil damper
Frame		Double cradle-type, tubular steel frame

WARRANTY INFORMATION (for U.S.A.)

Please refer to your copy of the Yamaha Owner's Warranty Guide* for details of the warranty offered on your new Yamaha.

The Warranty Guide contains the warranty policy, an explanation of the warranty, and other important information. Becoming familiar with these policies will be to your advantage in making the best use of Yamaha's warranty programs.

There are certain requirements which you must meet in order to qualify for warranty coverage.

FIRST, your new Yamaha must be operated and maintained properly, as explained in this manual. If you have any questions about any procedure in this manual, please consult your dealer. ABUSE AND NEGLECTED MAINTENANCE MAY LEAD TO MECHANICAL FAILURES WHICH CANNOT BE COVERED UNDER WARRANTY.

SECOND, IF ANY PROBLEMS OCCUR WHICH YOU FEEL SHOULD BE COVERED UNDER WARRANTY, NOTIFY YOUR DEALER IMMEDIATELY. Don't delay, as small problems left unrequired can become large problems which may not be covered under warranty.

We recommend that the Warranty Guide be used as a folder in which you may keep your registration and other important documents related to your new Yamaha.

* The Yamaha Owner's Warranty Guide is to be supplied by your Yamaha dealer at the time of purchase. If you did not receive one or have lost yours, you may obtain extra copies upon request from your Yamaha dealer or by writing to:

YAMAHA INTERNATIONAL CORPORATION
P.O.Box 6600
Buena Park, California 90620
Attn: Warranty Department

MEMO

