

PARTS CATALOGUE

YZ250R (5UP1) S.AFRICA 2003

www.legends-yamaha-enduros.com

YAMAHA
GENUINE
Parts & Accessories

1B5UP-100E1



A4

FOREWORD

This Parts Catalogue is related to the parts for the model(s) in the below frame. When you are ordering replacement parts, please refer to this Parts Catalogue and quote both part numbers and part names correctly.

YZ250R(5UP1/5UP4), YZ250(5UP2/5UP3)

1. Modifications or additions which have been made after issue of the Parts Catalogue will be announced in the Yamaha Parts News. It is advisable that you make necessary corrections to the Parts Catalogue according to the Yamaha Parts News.

2. Abbreviations

The Following abbreviations are used in this Parts Catalogue.

“UR” Use specified parts number.

“UN” Use as many as needed.

“AP” Alternate Parts

“LM” Local Made (Parts need to be ordered locally)

“F#” Frame No. (Applicable machine No.)

3. Parts, which are to be supplied in an assembly, are listed with a dot(.) in front of the part name as shown below.

EXAMPLE

CARBURETOR ASSY

.JET, PILOT

.NOZZLE, MAIN

4. Number of component for assembly

The numeral appearing to the right of each component part indicates the quantity of parts for each assembly unit.

EXAMPLE

PART NO.	DESCRIPTION	Q'TY	REMARKS
2F5-83310-60	FRONT FLASHER LIGHT ASSY	2	
115-83311-60	.BULB (6V-18W)	1	
1M1-83309-60	.REFLECTOR	1	

5. Applicable colors of graphics are represented in the “REMARKS” as shown below.

PART NO.	DESCRIPTION	Q'TY	REMARKS
2N4-24110-00-X5	FUEL TANK COMP.	1	MXR
3J1-24240-10	.GRAPHIC, FUEL TANK	1	FOR MXR

6. Applicable Serial No.

Engine Serial No.

Frame Serial No.

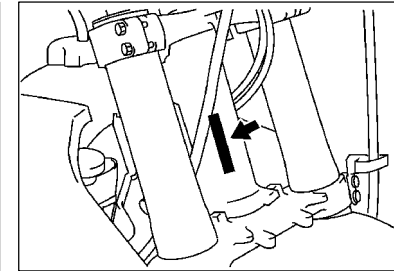
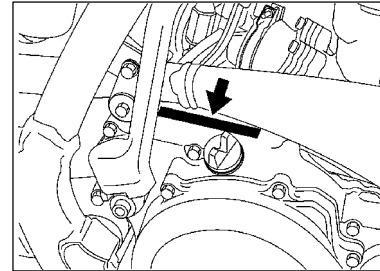

7. Note that the illustrations for reference in finding parts numbers, not to be used for assembling. When assembling, please use the applicable service manual.

8. The asterisk (*) before a reference number indicates modification items after the first edition.

MODEL LABEL

(1) A label called "Model Label" is affixed in the location as indicated in (3) below.
 When using this parts catalogue, please be sure to cross-refer the "model code – production code No." in the catalogue to the "model code – production code No." indicated on the Model Label affixed onto the product concerned.

(2) "Model Label" Indication

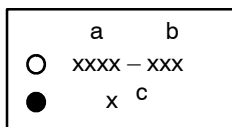

a: Model Type Code
 b: Production Code No.
 c: Colouring Type

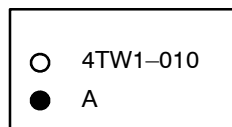

(3) Model Label Affixing Location

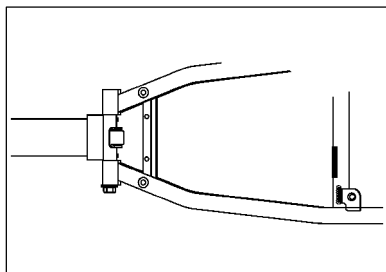

(4) Model Code – Production Code Number of Model Listed in This Parts Catalog

Model Code	Production Code No.	Country (destination)	Model Code	Production Code No.	Country (destination)
5UP1					
	030	SOUTH AFRICA			

www.legends-yamaha-online.com

(5) Coloring Information

Model Code	Colouring type code	Colour code	Colour Name	Abbreviation
5UP1	A	0583	DEEP PURPLISH BLUE SOLID E	DPBSE

CONTENTS

ENGINE

CYLINDER HEAD	B2
GOVERNOR	B4
CRANKSHAFT. PISTON	B5
WATER PUMP	B6
RADIATOR. HOSE	B7
INTAKE	B8
CARBURETOR	B9
EXHAUST	B13
CRANKCASE	B14
CRANKCASE COVER 1	B15
STARTER	C2
CLUTCH	C3
TRANSMISSION	C5
SHIFT CAM. FORK	C7
SHIFT SHAFT	C8

CHASSIS

FRAME	C9
FENDER	C11
SIDE COVER	C12
REAR ARM	C13
REAR SUSPENSION	C15
STEERING	D3
FRONT FORK	D4
FUEL TANK	D7
SEAT	D9
FRONT WHEEL	D10
FRONT BRAKE CALIPER	D11
REAR WHEEL	D12

REAR BRAKE CALIPER	D14
STEERING HANDLE. CABLE	D15
FRONT MASTER CYLINDER	E2
STAND. FOOTREST	E3
REAR MASTER CYLINDER	E4
GENERATOR	E5
HANDLE SWITCH. LEVER	E6
ELECTRICAL 1	E7
ALTERNATE (CHASSIS)	E8
OPTIONAL PARTS 1	E10

www.legends-yamaha-enduros.com

FIG. 1 CYLINDER HEAD

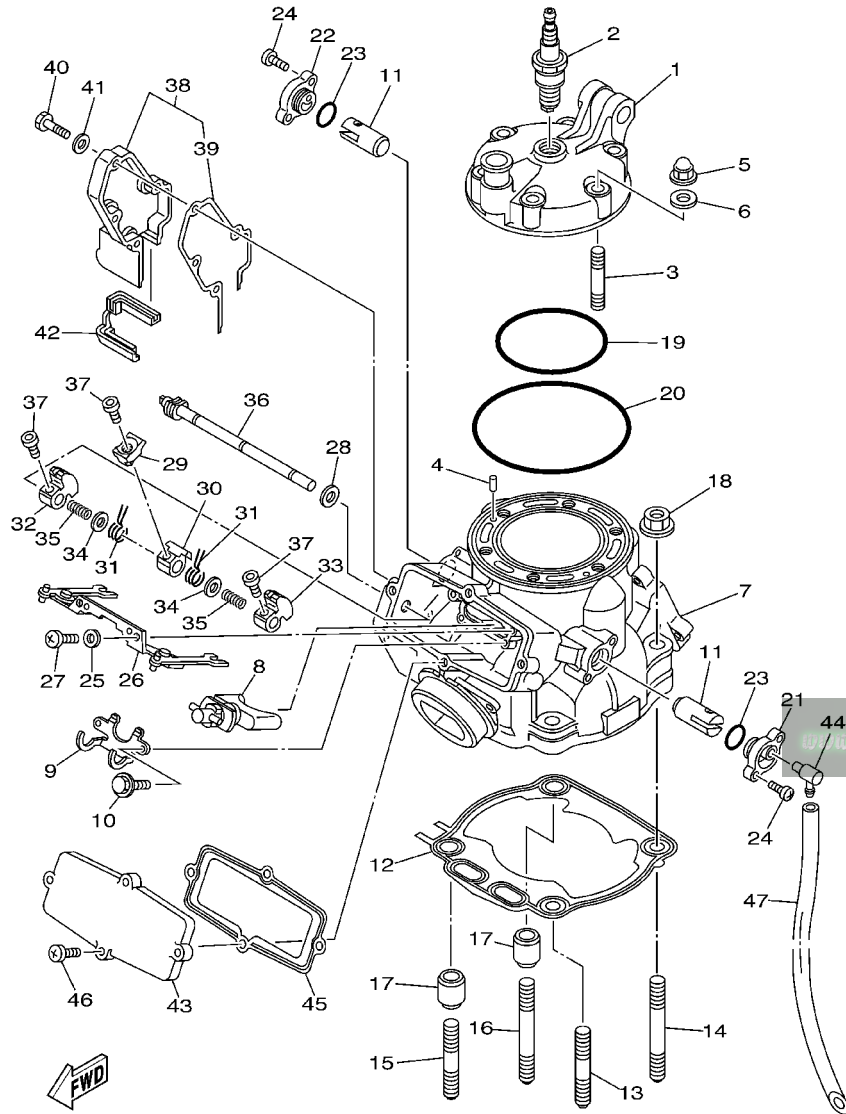

5NX1100-A010

REF. NO.	PART NO.	DESCRIPTION	5UP1	5UP2	5UP3	5UP4	REMARKS
1	5UP-11111-00	HEAD, CYLINDER 1	1			1	
2	NGK-BR8EG-PK10	PLUG, SPARK (NGKBR8EG)	1				
3	90116-08394	BOLT, STUD	6	6	6	6	
4	93604-08071	PIN, DOWEL	2	2	2	2	
5	90176-08026	NUT, CROWN	6	6	6	6	
6	90201-080L8	WASHER, PLATE	6	6	6	6	
7	5UP-11311-00	CYLINDER 1	1	1	1	1	
8	5NX-1131D-01	VALVE ASSY	1	1	1	1	
9	5CU-1131U-10	HOLDER 3	1	1	1	1	
10	90109-05001	BOLT	2	2	2	2	
11	5CU-1132A-00	VALVE 2	2	2	2	2	
12	5UP-11351-00	GASKET, CYLINDER	1	1	1	1	
13	90116-10314	BOLT, STUD	1	1	1	1	
14	95617-10660	BOLT, STUD	1	1	1	1	
15	90116-10314	BOLT, STUD	1	1	1	1	
16	95617-10660	BOLT, STUD	1	1	1	1	
17	99590-14016	PIN, DOWEL	2	2	2	2	
18	90179-10M35	NUT	4	4	4	4	
19	93210-74316	O-RING	1	1	1	1	
20	93211-02703	O-RING	1	1	1	1	
21	5CU-1131E-00	HOLDER 1	1	1	1	1	
22	5CU-1131P-00	HOLDER 4	1	1	1	1	
23	93210-15639	O-RING	2	2	2	2	
24	98507-05012	SCREW	4	4	4	4	
25	90201-057H5	WASHER, PLATE	2	2	2	2	

FIG. 1 CYLINDER HEAD

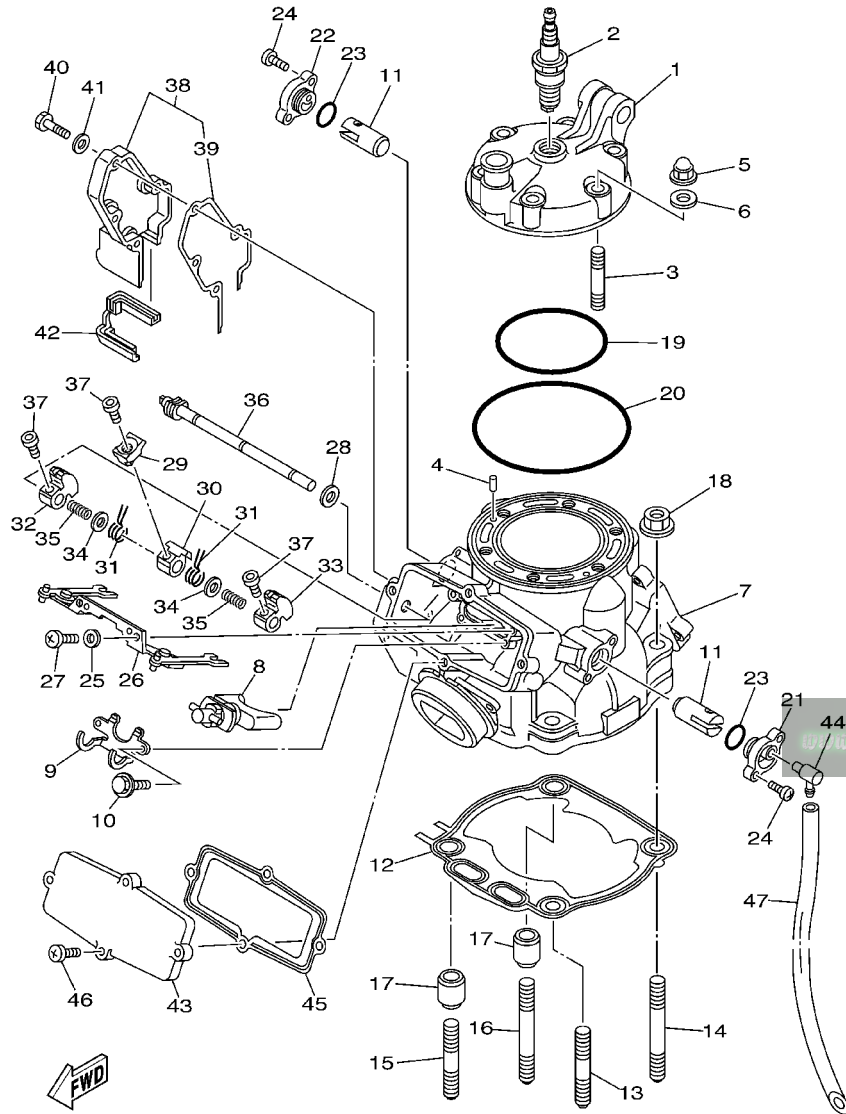

5NX1100-A010

REF. NO.	PART NO.	DESCRIPTION	5UP1	5UP2	5UP3	5UP4	REMARKS
26	5CU-11830-00	LINK ASSY	1	1	1	1	
27	98907-05012	SCREW, BIND	2	2	2	2	
28	93104-08040	OIL SEAL	1	1	1	1	
29	5NX-11395-00	HOLDER	1	1	1	1	
30	4SS-11832-00	LEVER, LINK	1	1	1	1	
31	90508-155B8	SPRING, TORSION	2	2	2	2	
32	5MW-1132E-00	PULLEY 1	1	1	1	1	
33	5MW-1132F-00	PULLEY 2	1	1	1	1	
34	90201-081G0	WASHER, PLATE	2	2	2	2	
35	90501-046L6	SPRING, COMPRESSION	2	2	2	2	
36	5CU-1131V-00	SHAFT 1	1	1	1	1	
37	91317-04008	BOLT	3	3	3	3	
38	5CU-11991-00	HOUSING 1	1	1	1	1	
39	5CU-11993-00	.GASKET	1	1	1	1	
40	97007-05020	BOLT	4	4	4	4	
41	92907-05600	WASHER, PLATE	4	4	4	4	
42	5CU-11995-00	SEAL, HOUSING	1	1	1	1	
43	5CU-1131M-00	COVER	1	1	1	1	
44	353-13115-01	CONNECTOR, SUCTION PIPE	1	1	1	1	
45	5CU-11354-00	GASKET	1	1	1	1	
46	98907-05016	SCREW, BIND	4	4	4	4	
47	90445-09777	HOSE (L300)	1	1	1	1	

FIG. 2 GOVERNOR

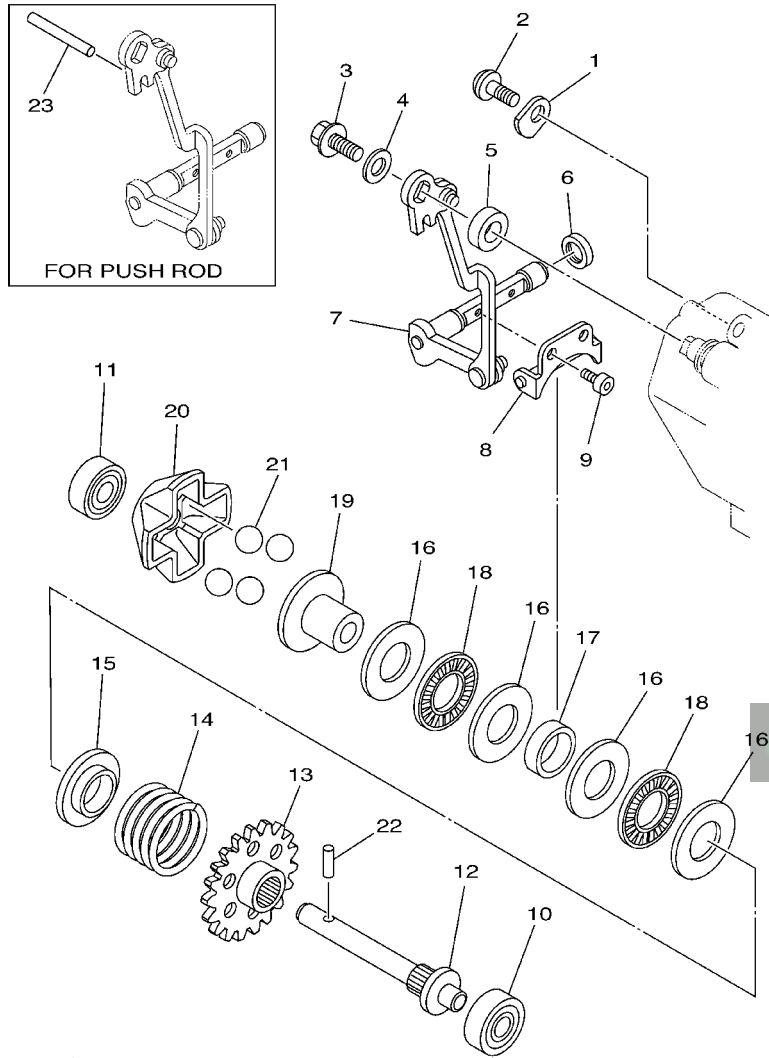

REF. NO.	PART NO.	DESCRIPTION	SUP1	SUP2	SUP3	SUP4	REMARKS
1	4JY-11915-01	PLATE, THRUST 1	1	1	1	1	
2	98907-05012	SCREW, BIND	1	1	1	1	
3	90105-05002	BOLT, FLANGE	1	1	1	1	
4	90201-057H5	WASHER, PLATE	1	1	1	1	
5	90387-085E1	COLLAR	1	1	1	1	
6	93104-08040	OIL SEAL	1	1	1	1	
7	5CU-11990-00	PUSH ROD ASSY	1	1	1	1	
8	3JE-11922-01	FORK, GOVERNOR	1	1	1	1	
9	91317-04006	BOLT	2	2	2	2	
10	93300-60801	BEARING (B0060)	1	1	1	1	KOYO
11	93300-60801	BEARING (B0060)	1	1	1	1	KOYO
12	5X4-11921-02	SHAFT, GOVERNOR	1	1	1	1	
13	5NY-11953-00	GEAR, GOVERNOR	1	1	1	1	
14	90501-256L2	SPRING, COMPRESSION	1	1	1	1	
15	5CU-11952-00	PLATE	1	1	1	1	
16	90201-150U6	WASHER, PLATE	4	4	4	4	
17	90387-152F2	COLLAR	1	1	1	1	
18	93340-21505	BEARING	2	2	2	2	
19	5CU-11912-00	RETAINER, WEIGHT	1	1	1	1	
20	5CU-11911-00	RETAINER	1	1	1	1	
21	93507-16020	BALL	4	4	4	4	
22	93603-14240	PIN, DOWEL	1	1	1	1	
23	93604-29184	PIN, DOWEL	1	1	1	1	AP



5NX1100-A020

FIG. 3 CRANKSHAFT. PISTON

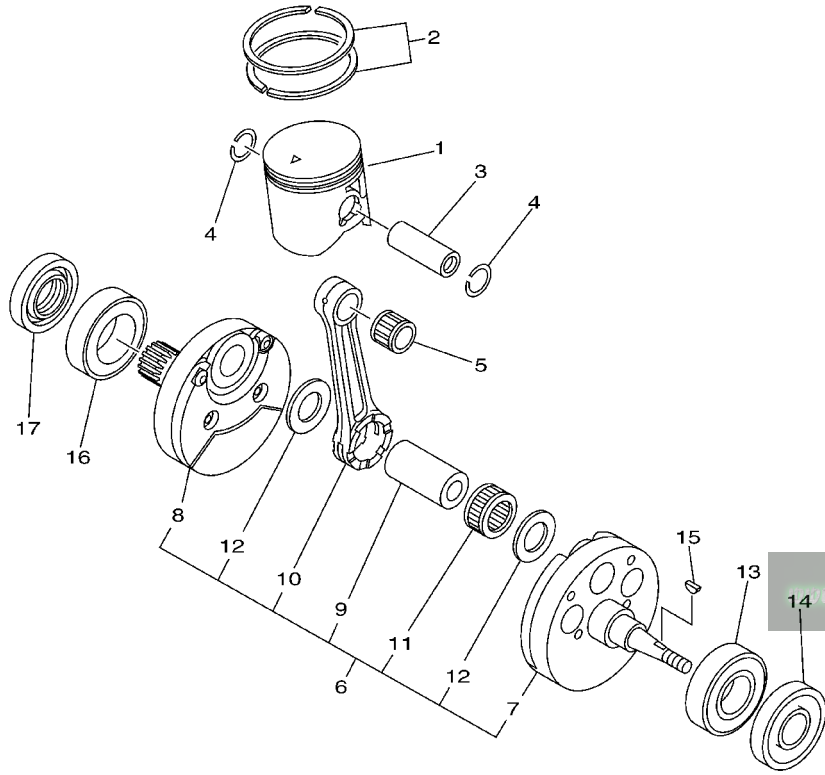

REF. NO.	PART NO.	DESCRIPTION	5UP1	5UP2	5UP3	5UP4	REMARKS
1	5NX-11631-00-A0	PISTON (STD)	1	1	1	1	UR
	5NX-11631-00-B0	PISTON (STD)	1	1	1	1	UR
	5NX-11631-00-C0	PISTON (STD)	1	1	1	1	UR
	5NX-11631-00-D0	PISTON (STD)	1	1	1	1	UR
2	5CU-11603-10	PISTON RING SET (STD)	1	1	1	1	
3	5UP-11633-00	PIN, PISTON	1	1	1	1	
4	93450-19052	CIRCLIP	2	2	2	2	
5	93310-218A6	BEARING	1	1	1	1	
6	5UP-11400-00	CRANKSHAFT ASSY	1	1	1	1	
7	5UP-11410-00	.CRANKSHAFT	1	1	1	1	
8	5MW-11420-00	.CRANKSHAFT	1	1	1	1	
9	5CU-11681-00	.PIN, CRANK 1	1	1	1	1	
10	5MW-11651-00	.ROD, CONNECTING	1	1	1	1	
11	93310-52406	.BEARING	1	1	1	1	
12	90209-24327	.WASHER	2	2	2	2	
13	93306-37808	BEARING	1	1	1	1	
14	93102-20485	OIL SEAL	1	1	1	1	
15	90280-03017	KEY, WOODRUFF	1	1	1	1	
16	93306-37808	BEARING	1	1	1	1	
17	93102-28004	OIL SEAL	1	1	1	1	



5MW1100-1030

FIG. 4 WATER PUMP

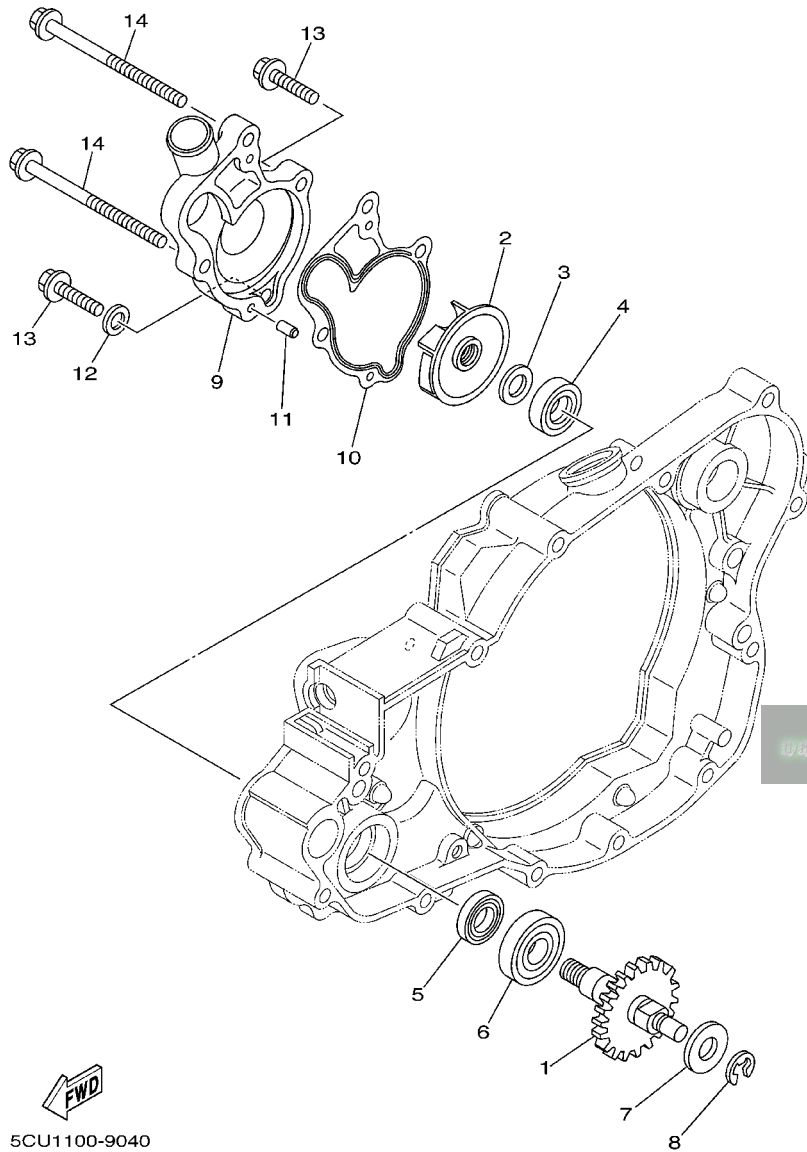

REF. NO.	PART NO.	DESCRIPTION					REMARKS
			5UP1	5UP2	5UP3	5UP4	
1	5CU-12459-00	GEAR, IMPELLER SHAFT	1	1	1	1	
2	5DJ-12451-00	IMPELLER, WATER PUMP	1	1	1	1	
3	90201-08512	WASHER, PLATE	1	1	1	1	
4	93109-11073	OIL SEAL	1	1	1	1	
5	93102-12106	OIL SEAL (SD 12-22-5 HS)	1	1	1	1	
6	93306-00105	BEARING (B6001)	1	1	1	1	
7	90201-08784	WASHER, PLATE	1	1	1	1	
8	99001-06600	CIRCLIP	1	1	1	1	
9	5MW-12422-00	COVER, HOUSING	1	1	1	1	
10	5CU-12428-00	GASKET, HOUSING COVER 2	1	1	1	1	
11	93604-10011	PIN, DOWEL	2	2	2	2	
12	90430-06014	GASKET	1	1	1	1	
13	95027-06025	BOLT, FLANGE	2	2	2	2	
14	95027-06065	BOLT, FLANGE	2	2	2	2	

5CU1100-9040

FIG. 5 RADIATOR. HOSE

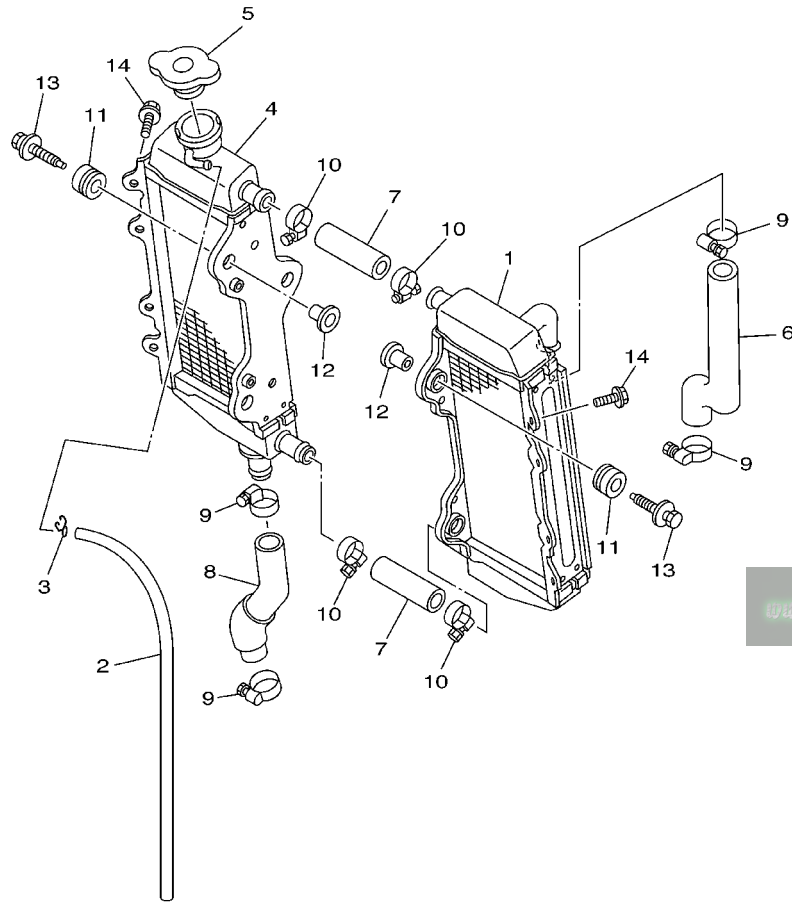

FWD
5NX1100-A050

www.legends-gamoha-enduros.com

REF. NO.	PART NO.	DESCRIPTION	5UP1	5UP2	5UP3	5UP4	REMARKS
1	5NX-1240A-00	RADIATOR ASSY	1	1	1	1	
2	91A20-05065	TUBE, FLEXIBLE VINYL	1	1	1	1	
3	90467-09006	CLIP	1	1	1	1	
4	5NX-12461-00	RADIATOR ASSY	1	1	1	1	
5	5HD-12462-00	CAP, RADIATOR	1	1	1	1	
6	5CU-12481-10	PIPE 1	1	1	1	1	
7	5NY-12482-00	PIPE 2	2	2	2	2	
8	5CU-12484-10	PIPE 4	1	1	1	1	
9	90450-28014	HOSE CLAMP ASSY	4	4	4	4	
10	90450-25037	HOSE CLAMP ASSY	4	4	4	4	
11	90480-15528	GROMMET	6	6	6	6	
12	90387-0614M	COLLAR	6	6	6	6	
13	90119-06038	BOLT, WITH WASHER	6	6	6	6	
14	95827-06010	BOLT, FLANGE	2	2	2	2	

FIG. 6 INTAKE

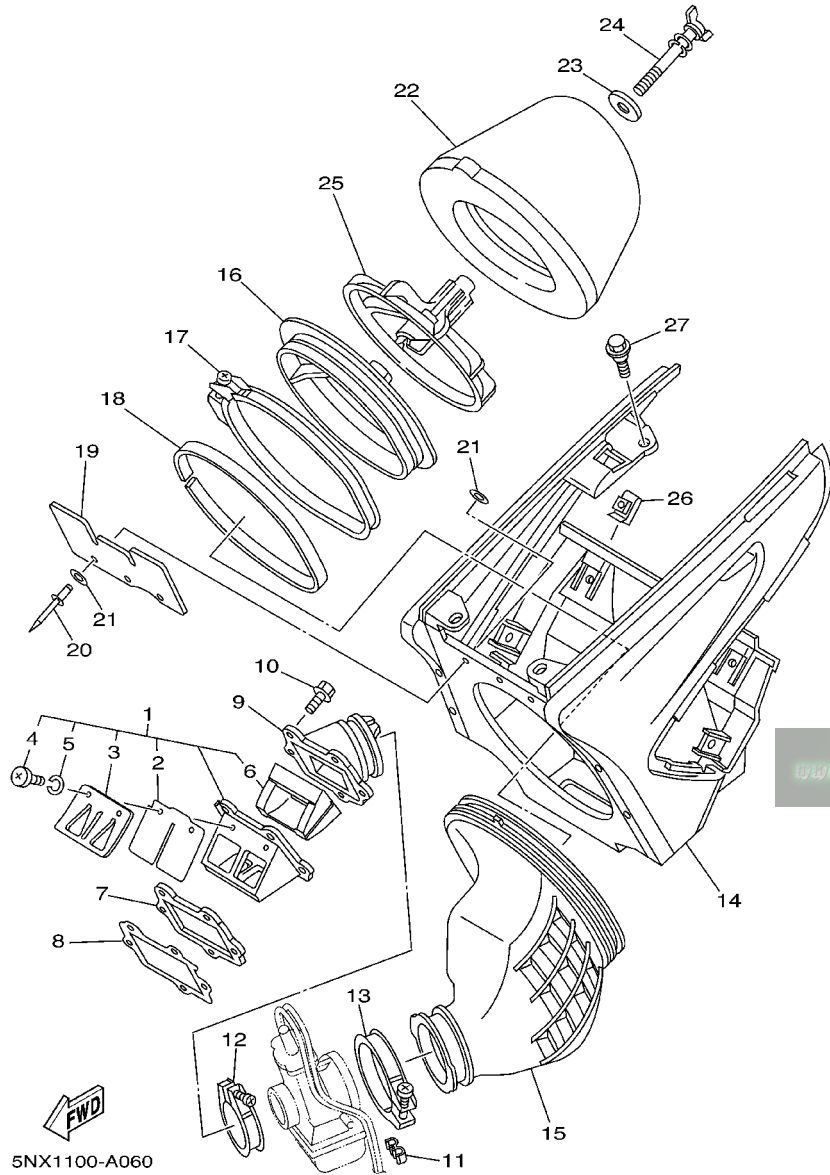

REF. NO.	PART NO.	DESCRIPTION	SUP1	SUP2	SUP3	SUP4	REMARKS
1	5NX-13610-00	REED VALVE ASSY	1	1	1	1	
2	5NX-13613-00	.REED, VALVE	2	2	2	2	
3	4XL-13616-00	.STOPPER, REED VALVE	2	2	2	2	
4	98507-03008	.SCREW	4	4	4	4	
5	92907-03100	.WASHER, SPRING	4	4	4	4	
6	4XL-13625-00	.SPACER, REED VALVE	1	1	1	1	
7	5NX-13624-00	PLATE, REED VALVE	1	1	1	1	
8	5NX-13622-00	GASKET, VALVE SEAT	1	1	1	1	
9	5NX-13565-00	JOINT, CARBURETOR	1	1	1	1	
10	91317-06025	BOLT	5	5	5	5	
11	90464-06214	CLAMP	2	2	2	2	
12	90450-51070	HOSE CLAMP ASSY	1	1	1	1	
13	90450-70072	HOSE CLAMP ASSY	1	1	1	1	
14	5NY-14401-01	AIR CLEANER CASE ASSY	1	1	1	1	
15	5NX-14453-00	JOINT, AIR CLEANER 1	1	1	1	1	
16	5NY-14459-00	HOLDER, GUIDE	1	1	1	1	
17	5NY-14455-10	BAND	1	1	1	1	
18	5NY-14442-00	SPACER	1	1	1	1	
19	5NY-14417-00	COVER 1	1	1	1	1	
20	90267-32070	RIVET, BLIND	3	3	3	3	
21	90201-03313	WASHER, PLATE	6	6	6	6	
22	4XM-14451-00	ELEMENT, AIR CLEANER	1	1	1	1	
23	90209-06096	WASHER	1	1	1	1	
24	90122-06035	BOLT, WING	1	1	1	1	
25	3JD-14458-01	GUIDE	1	1	1	1	
26	90183-06023	NUT, SPRING	4	4	4	4	
27	90109-067F4	BOLT	4	4	4	4	

FIG. 7 CARBURETOR

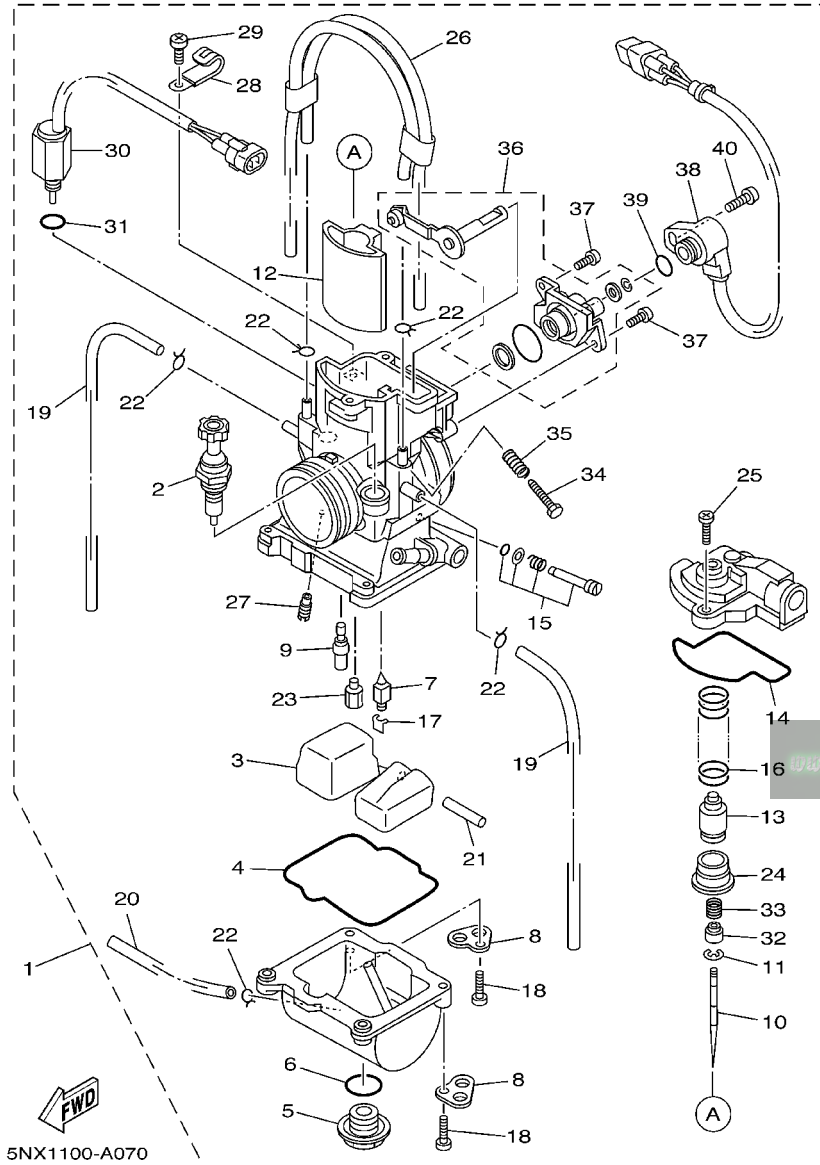

REF. NO.	PART NO.	DESCRIPTION	SUP1	SUP2	SUP3	SUP4	REMARKS
1	5NX-14101-00	CARBURETOR ASSY 1	1			1	
2	4JT-14171-00	.PLUNGER, STARTER	1	1	1	1	
3	4SR-14985-00	.FLOAT	1	1	1	1	
4	4JT-14984-00	.GASKET, FLOAT CHAMBER	1	1	1	1	
5	4MX-14115-00	.PLUG, SCREW	1	1	1	1	
6	4MX-14561-00	.O-RING	1	1	1	1	
7	4MX-14392-00	.VALVE, NEEDLE	1	1	1	1	
8	4XL-14146-00	.PLATE	2	2	2	2	
9	4MX-14948-07	.JET, SLOW (#50)	1	1	1	1	STD
	4MX-14948-02	.JET, SLOW (#38)	1	1	1	1	AP
	4MX-14948-03	.JET, SLOW (#40)	1	1	1	1	AP
	4MX-14948-04	.JET, SLOW (#42)	1	1	1	1	AP
	4MX-14948-05	.JET, SLOW (#45)	1	1	1	1	AP
	4MX-14948-06	.JET, SLOW (#48)	1	1	1	1	AP
	4MX-14948-08	.JET, SLOW (#52)	1	1	1	1	AP
	4MX-14948-09	.JET, SLOW (#55)	1	1	1	1	AP
	4MX-14948-10	.JET, SLOW (#58)	1	1	1	1	AP
	4MX-14948-11	.JET, SLOW (#60)	1	1	1	1	AP
	4MX-14948-12	.JET, SLOW (#62)	1	1	1	1	AP
10	4SR-14916-EJ	.NEEDLE (N3EJ)	1	1		1	STD
	4SR-14916-RW	.NEEDLE (N8RW)	1	1		1	AP
	4SR-14916-EW	.NEEDLE (N3EW)	1	1		1	AP
	4SR-14916-RJ	.NEEDLE (N8RJ)	1	1		1	AP
	4SR-14916-CJ	.NEEDLE (N3CJ)	1	1		1	AP

FIG. 7 CARBURETOR

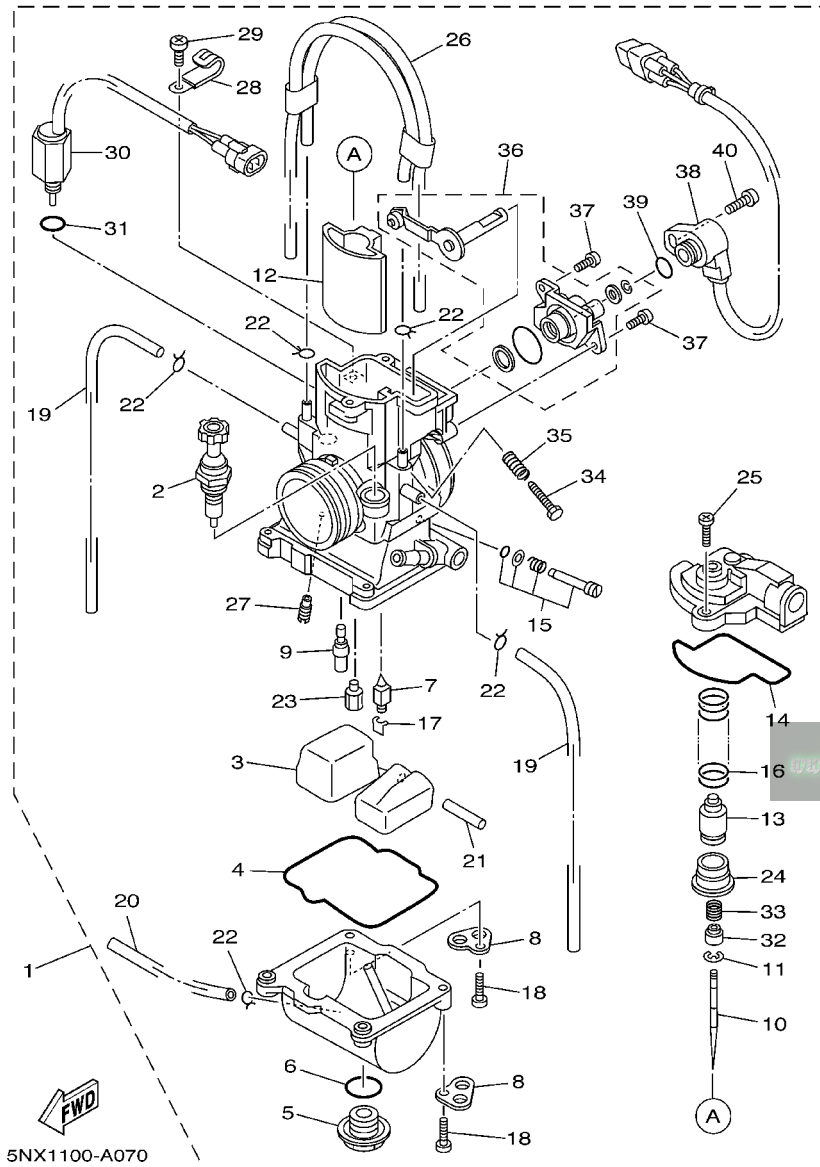

5NX1100-A070

REF. NO.	PART NO.	DESCRIPTION	SUP1	SUP2	SUP3	SUP4	REMARKS
10	4SR-14916-EK	.NEEDLE (N3EK)	1	1		1	AP
	4SR-14916-CK	.NEEDLE (N3CK)	1	1		1	AP
11	4MX-14919-00	.CLIP	1	1	1	1	
12	5HC-14340-A7	.VALVE ASSY	1	1	1	1	
13	5HC-14261-00	.HOLDER	1	1	1	1	
14	5HC-14126-00	.GASKET	1	1	1	1	
15	4SR-14105-00	.PILOT SCREW SET	1	1	1	1	
16	5HC-14131-00	.SPRING, THROTTLE VALVE	1	1	1	1	
17	663-14159-00	.CLIP	1	1	1	1	
18	98502-04014	.SCREW, PAN HEAD	4	4	4	4	
19	4XL-14197-10	.PIPE	2	2	2	2	
20	4XL-14196-10	.PIPE	1	1	1	1	
21	676-14548-00	.PIN, FLOAT ARM	1	1	1	1	
22	3TJ-14137-40	.CLIP	5	5	5	5	
23	4MX-14943-93	.JET, MAIN (#178)	1	1	1	1	STD
	4MX-14943-90	.JET, MAIN (#162)	1	1	1	1	AP
	4MX-14943-40	.JET, MAIN (#165)	1	1	1	1	AP
	4MX-14943-91	.JET, MAIN (#168)	1	1	1	1	AP
	4MX-14943-41	.JET, MAIN (#170)	1	1	1	1	AP
	4MX-14943-92	.JET, MAIN (#172)	1	1	1	1	AP
	4MX-14943-42	.JET, MAIN (#175)	1	1	1	1	AP

FIG. 7 CARBURETOR

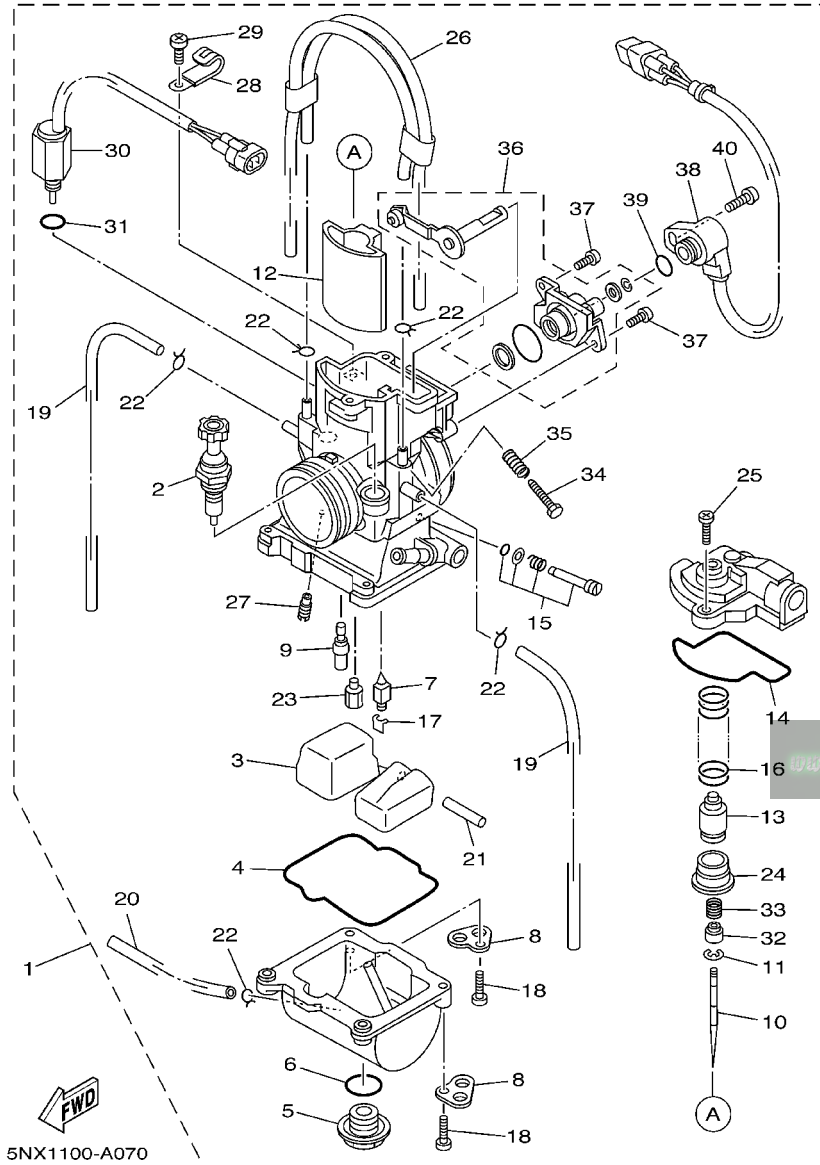

REF. NO.	PART NO.	DESCRIPTION	SUP1	SUP2	SUP3	SUP4	REMARKS
23	4MX-14943-43	.JET, MAIN (#180)	1	1	1	1	AP
	4MX-14943-94	.JET, MAIN (#182)	1	1	1	1	AP
	4MX-14943-44	.JET, MAIN (#185)	1	1	1	1	AP
	4MX-14943-95	.JET, MAIN (#188)	1	1	1	1	AP
	4MX-14943-45	.JET, MAIN (#190)	1	1	1	1	AP
24	4MX-14194-00	.RING	1	1	1	1	
25	98502-04012	.SCREW, PAN HEAD	2	2	2	2	
26	4XL-1410E-00	.HOSE	1	1	1	1	
27	4JT-1494F-07	.JET (#50)	1	1	1	1	STD
	4JT-1494F-03	.JET (#40)	1	1	1	1	AP
	4JT-1494F-09	.JET (#55)	1	1	1	1	AP
	4JT-1494F-11	.JET (#60)	1	1	1	1	AP
	4JT-1494F-13	.JET (#65)	1	1	1	1	AP
28	5HC-14146-00	.PLATE	1	1	1	1	
29	98580-04006	.SCREW, PAN HEAD	1	1	1	1	
30	5NX-1410H-00	.FUEL CUT SOLENOID VALVE	1	1	1	1	
31	4JT-14147-00	.O-RING	1	1	1	1	
32	5HC-14264-00	.COLLAR	1	1	1	1	
33	5HC-14275-00	.SPRING	1	1	1	1	
34	5HC-14922-00	.SCREW, THROTTLE	1	1	1	1	
35	5HC-14934-00	.SPRING, THROTTLE STOP	1	1	1	1	
36	5NX-14208-00	.LEVER COMP. 1	1	1	1	1	
37	5HC-14216-00	.SCREW	2	2	2	2	
38	5NX-85885-00	.THROTTLE SENSOR ASSY	1	1	1	1	
39	5NX-14562-00	.O-RING	1	1	1	1	

FIG. 7 CARBURETOR

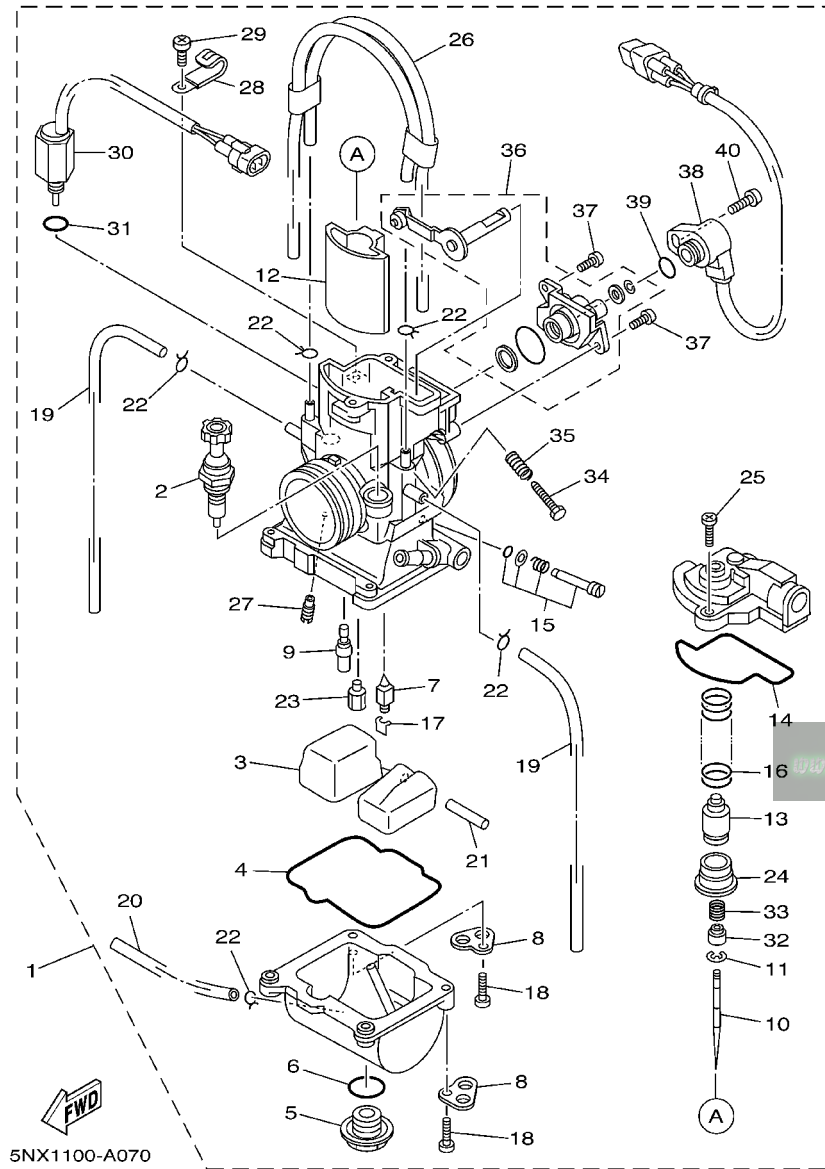

REF. NO.	PART NO.	DESCRIPTION	SUP1	SUP2	SUP3	SUP4	REMARKS
40	5NX-14216-00	.SCREW	1	1	1	1	

FIG. 8 EXHAUST

REF. NO.	PART NO.	DESCRIPTION	SUP1	SUP2	SUP3	SUP4	REMARKS
1	5MW-14610-10	EXHAUST PIPE ASSY 1	1		1	1	
2	5MW-14642-00	SEAL, EXHAUST	2	2	2	2	
3	90507-20052	SPRING, TENSION	2	2	2	2	
4	5CU-14771-00	STAY, MUFFLER 1	1	1	1	1	
5	90480-16561	GROMMET	1	1	1	1	
6	90387-063G3	COLLAR	1	1	1	1	
7	90201-06071	WASHER, PLATE	1	1	1	1	
8	483-14781-02	STAY, MUFFLER 2	1	1	1	1	
9	95027-06012	BOLT, FLANGE	1	1	1	1	
10	90119-06192	BOLT, WITH WASHER	1	1	1	1	
11	95027-06025	BOLT, FLANGE	1	1	1	1	
12	95027-08012	BOLT, FLANGE	1	1	1	1	
13	90201-08730	WASHER, PLATE	1	1	1	1	
14	3JE-14615-01	JOINT, EXHAUST 1	1	1	1	1	
15	5NX-14753-00	SILENCER, EXHAUST	1	1	1	1	UR
16	92017-06010	.BOLT	2	2	2	2	
17	5CU-1469A-00	.FIBER	1	1	1	1	UR
18	90480-16561	GROMMET	1	1	1	1	
19	90387-063G3	COLLAR	1	1	1	1	
20	90480-16404	GROMMET	1	1	1	1	
21	90387-06039	COLLAR	1	1	1	1	
22	95027-06025	BOLT, FLANGE	1	1	1	1	
23	90201-06071	WASHER, PLATE	1	1	1	1	

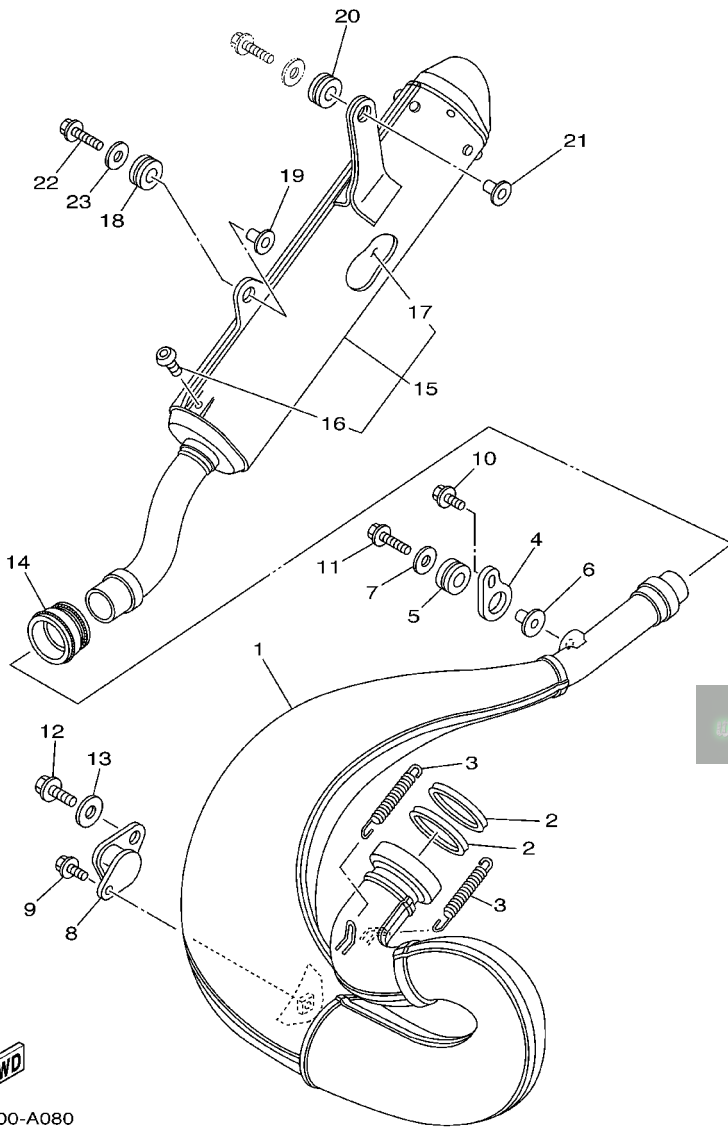

5NX1100-A080

FIG. 9 CRANKCASE

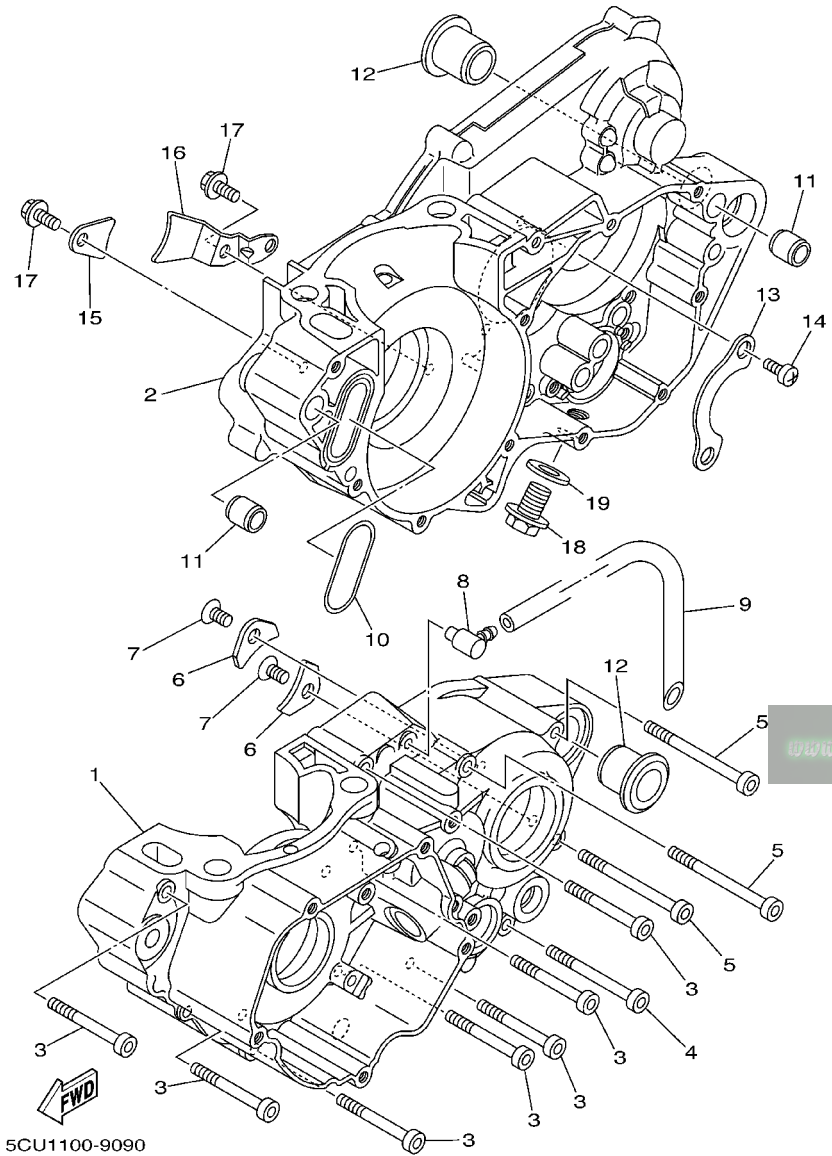

5CU1100-9090

REF. NO.	PART NO.	DESCRIPTION	5UP1	5UP2	5UP3	5UP4	REMARKS
1	5NX-15111-00	CRANKCASE 1	1	1	1	1	
2	5NX-15121-00	CRANKCASE 2	1	1	1	1	
3	91317-06050	BOLT	7	7	7	7	
4	91317-06060	BOLT	1	1	1	1	
5	91317-06070	BOLT	3	3	3	3	
6	4JT-15381-01	PLATE, BEARING COVER	2	2	2	2	
7	90149-06326	SCREW	2	2	2	2	
8	353-13115-01	CONNECTOR, SUCTION PIPE	1	1	1	1	
9	90445-08376	HOSE (L330)	1	1	1	1	
10	5CU-15454-00	GASKET, AIR CLEANER COVER 1	1	1	1	1	
11	93612-16254	PIN, DOWEL	2	2	2	2	
12	90387-18007	COLLAR	2	2	2	2	
13	4L0-17471-00	PLATE, COVER	1	1	1	1	
14	90157-06077	SCREW, PAN HEAD	2	2	2	2	
15	4V4-15118-00	HOLDER	1	1	1	1	
16	5CU-15118-00	HOLDER	1	1	1	1	
17	90105-06556	BOLT, FLANGE	2	2	2	2	
18	90340-12059	PLUG, STRAIGHT SCREW	1	1	1	1	
19	90430-12227	GASKET	1	1	1	1	

FIG. 10 CRANKCASE COVER 1

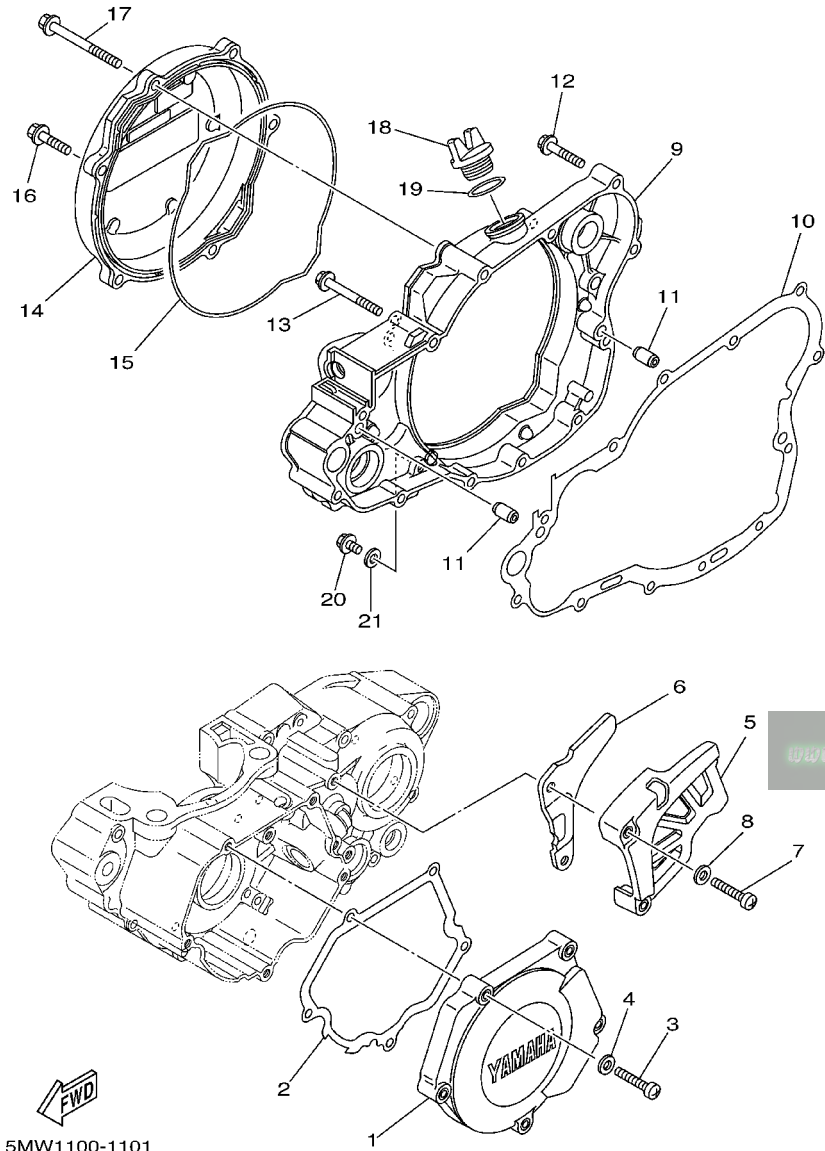

FWD
5MW1100-1101

REF. NO.	PART NO.	DESCRIPTION	SUP1	SUP2	SUP3	SUP4	REMARKS
1	5CU-15411-00	COVER, CRANKCASE 1	1	1	1	1	
2	5CU-15451-00	GASKET, CRANKCASE COVER 1	1	1	1	1	
3	98507-06030	SCREW	5	5	5	5	
4	92907-06600	WASHER, PLATE	5	5	5	5	
5	5CU-15421-00	COVER, CRANKCASE 2	1	1	1	1	
6	5HC-17466-00	GUIDE, CHAIN	1	1	1	1	
7	98507-06035	SCREW	2	2	2	2	
8	92907-06600	WASHER, PLATE	2	2	2	2	
9	5NX-15431-00	COVER, CRANKCASE 3	1	1	1	1	
10	5CU-15462-00	GASKET, CRANKCASE COVER 3	1	1	1	1	
11	99530-08016	PIN, DOWEL	2	2	2	2	
12	95027-06030	BOLT, FLANGE	8	8	8	8	
13	95027-06050	BOLT, FLANGE	1	1	1	1	
14	5MW-15415-00	COVER, GENERATOR	1	1	1	1	
15	5CU-15463-00	GASKET, CARBURETOR COVER 2	1	1	1	1	
16	95027-06025	BOLT, FLANGE	5	5	5	5	
17	95027-06065	BOLT, FLANGE	1	1	1	1	
18	3Y1-15363-00	PLUG, OIL	1	1	1	1	
19	93210-19123	O-RING	1	1	1	1	
20	95027-06010	BOLT, FLANGE	1	1	1	1	
21	90430-06014	GASKET	1	1	1	1	

FIG. 11 STARTER

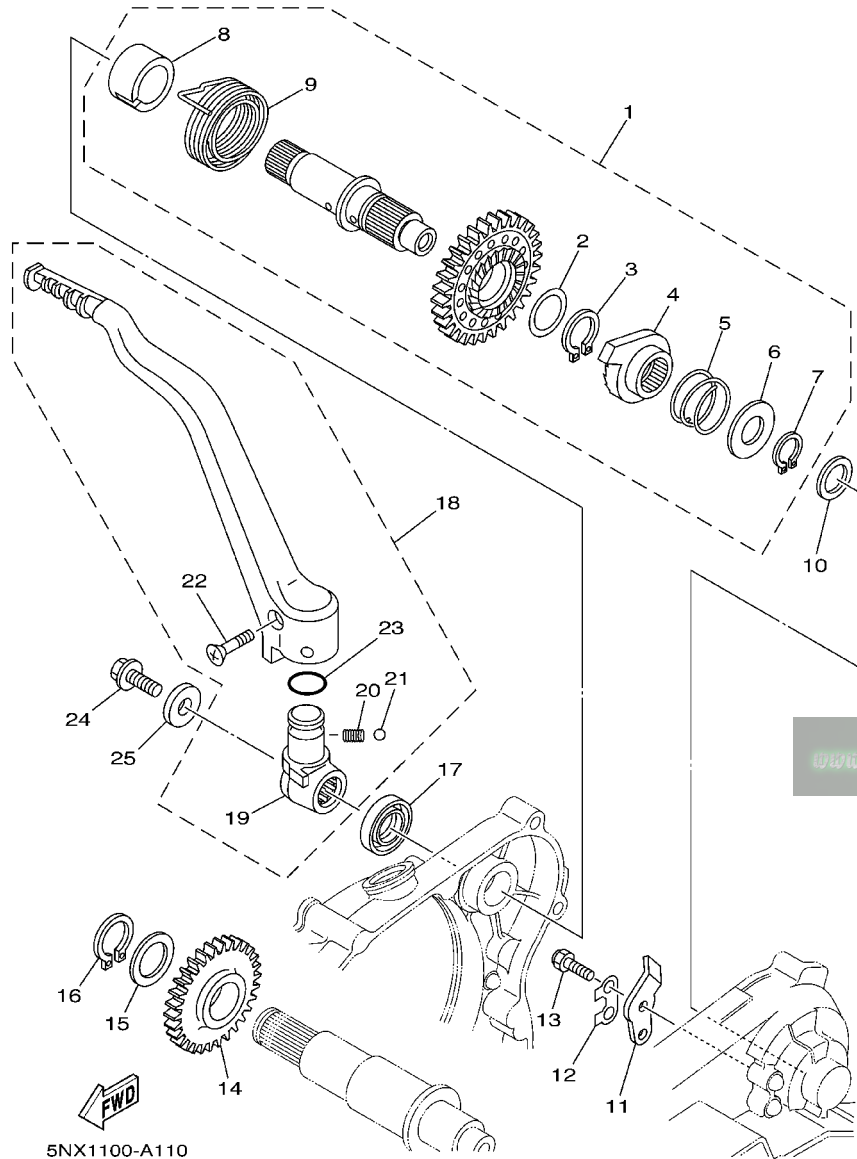

REF. NO.	PART NO.	DESCRIPTION	SUP1	SUP2	SUP3	SUP4	REMARKS
1	5NX-15601-00	KICK SHAFT ASSY	1	1	1	1	
2	90201-20685	.WASHER, PLATE (T=0.5)	1	1	1	1	
3	93410-20038	.CIRCLIP	1	1	1	1	
4	4GY-15671-00	.WHEEL, RATCHET	1	1	1	1	
5	90501-16016	.SPRING, COMPRESSION	1	1	1	1	
6	90201-167P7	.WASHER, PLATE	1	1	1	1	
7	99009-16400	.CIRCLIP	1	1	1	1	
8	5NL-15664-00	.GUIDE, SPRING	1	1	1	1	
9	90508-305B0	.SPRING, TORSION	1	1	1	1	
10	90201-162H4	WASHER, PLATE	1	1	1	1	
11	214-15674-00	GUIDE, RATCHET WHEEL	1	1	1	1	
12	214-15686-00	WASHER, LOCK	1	1	1	1	
13	97027-06016	BOLT	2	2	2	2	
14	5CU-15651-00	GEAR, KICK IDLE	1	1	1	1	
15	90201-20276	WASHER, PLATE (T=1.0)	1	1	1	1	
16	99009-20400	CIRCLIP	1	1	1	1	
17	93102-18278	OIL SEAL	1	1	1	1	
18	5NX-15620-00	KICK CRANK ASSY	1	1	1	1	
19	5NX-15621-01	.BOSS, KICK CRANK	1	1	1	1	
20	90501-12081	.SPRING, COMPRESSION	1	1	1	1	
21	93507-32009	.BALL	1	1	1	1	
22	90152-06010	.SCREW, COUNTERSUNK	1	1	1	1	
23	93210-17570	.O-RING	1	1	1	1	
24	90109-085E2	BOLT	1	1	1	1	
25	90201-08326	WASHER, PLATE	1	1	1	1	

FIG. 12 CLUTCH

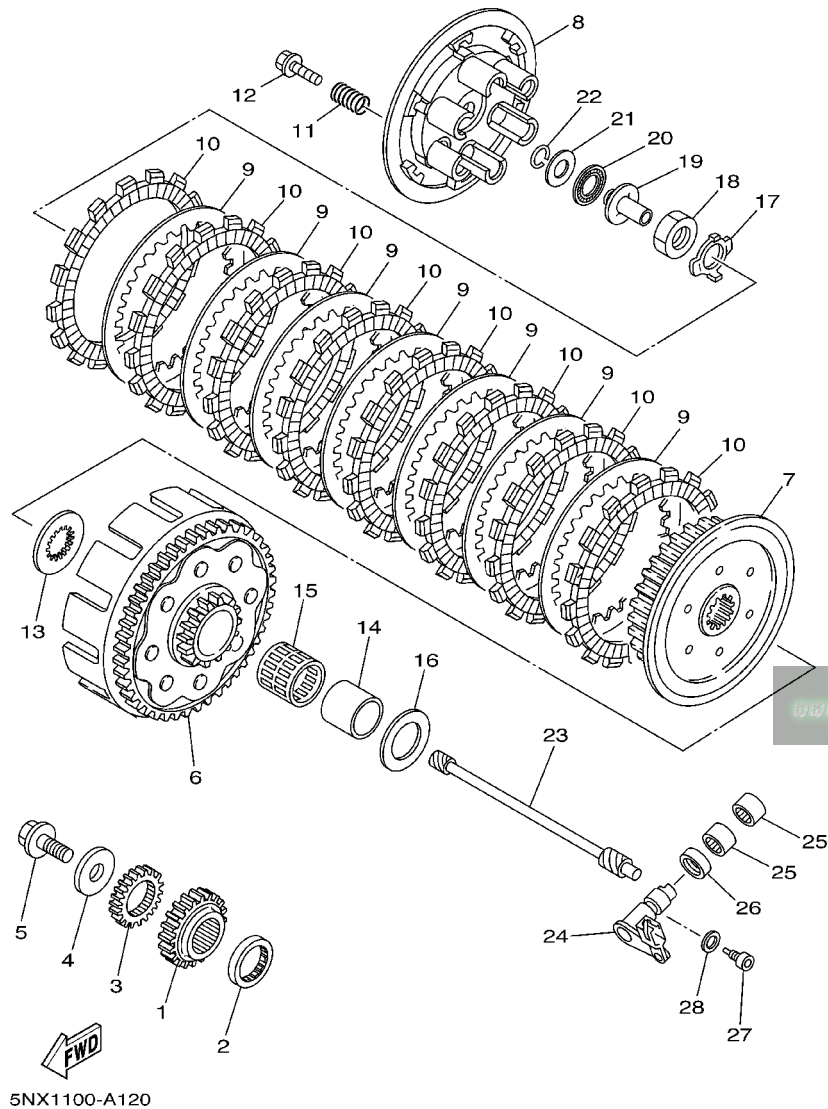

REF. NO.	PART NO.	DESCRIPTION	SUP1	SUP2	SUP3	SUP4	REMARKS
1	5DJ-16111-00	GEAR, PRIMARY DRIVE	1	1	1	1	
2	5MW-16113-00	WASHER, THRUST 1	1	1	1	1	
3	5CU-11956-00	GEAR, GOVERNOR DRIVE	1	1	1	1	
4	90201-105P3	WASHER, PLATE	1	1	1	1	
5	90105-10445	BOLT, FLANGE	1	1	1	1	
6	5DJ-16150-00	PRIMARY DRIVEN GEAR COMP.	1	1	1	1	
7	5NX-16371-00	BOSS, CLUTCH	1	1	1	1	
8	5JG-16351-00	PLATE, PRESSURE 1	1	1	1	1	
9	4X7-16325-00	PLATE, CLUTCH 2	7	7	7	7	
10	3XK-16321-00	PLATE, FRICTION	8	8	8	8	
11	90501-237L0	SPRING, COMPRESSION	6	6	6	6	
12	90159-06010	SCREW, WITH WASHER	6	6	6	6	
13	5CU-16154-00	PLATE, THRUST 1	1	1	1	1	
14	2VM-16181-00	SPACER 1	1	1	1	1	
15	93310-230T7	BEARING	1	1	1	1	
16	2K7-16154-00	PLATE, THRUST 1	1	1	1	1	
17	90215-20231	WASHER, LOCK	1	1	1	1	
18	90170-20255	NUT	1	1	1	1	
19	4XL-16356-00	ROD, PUSH 1	1	1	1	1	
20	93340-21505	BEARING	1	1	1	1	
21	90201-125L6	WASHER, PLATE	1	1	1	1	
22	93440-10085	CIRCLIP	1	1	1	1	
23	5CU-16357-10	ROD, PUSH 2	1	1	1	1	
24	5CU-16380-10	PUSH LEVER ASSY	1	1	1	1	
25	93315-11206	BEARING	2	2	2	2	
26	93102-12224	OIL SEAL	1	1	1	1	
27	90109-056G0	BOLT	1	1	1	1	

FIG. 12 CLUTCH

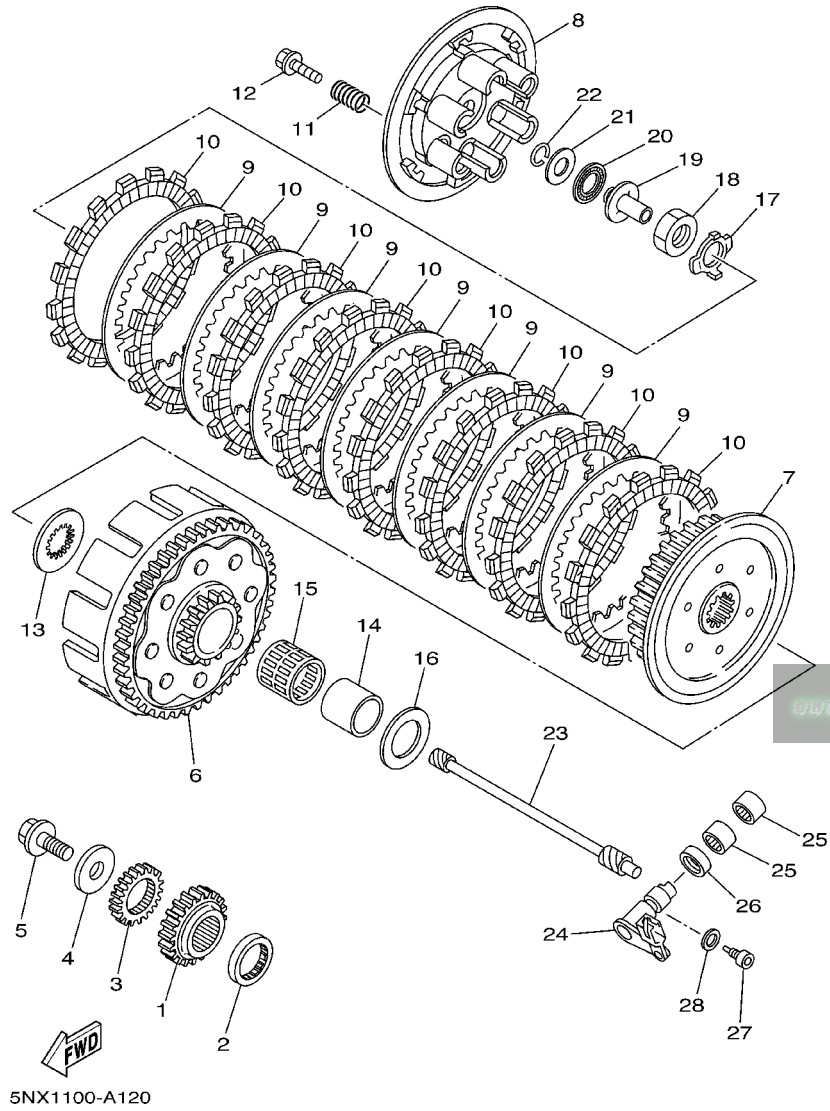

REF. NO.	PART NO.	DESCRIPTION	SUP1	SUP2	SUP3	SUP4	REMARKS
28	90430-05242	GASKET	1	1	1	1	

FIG. 13 TRANSMISSION

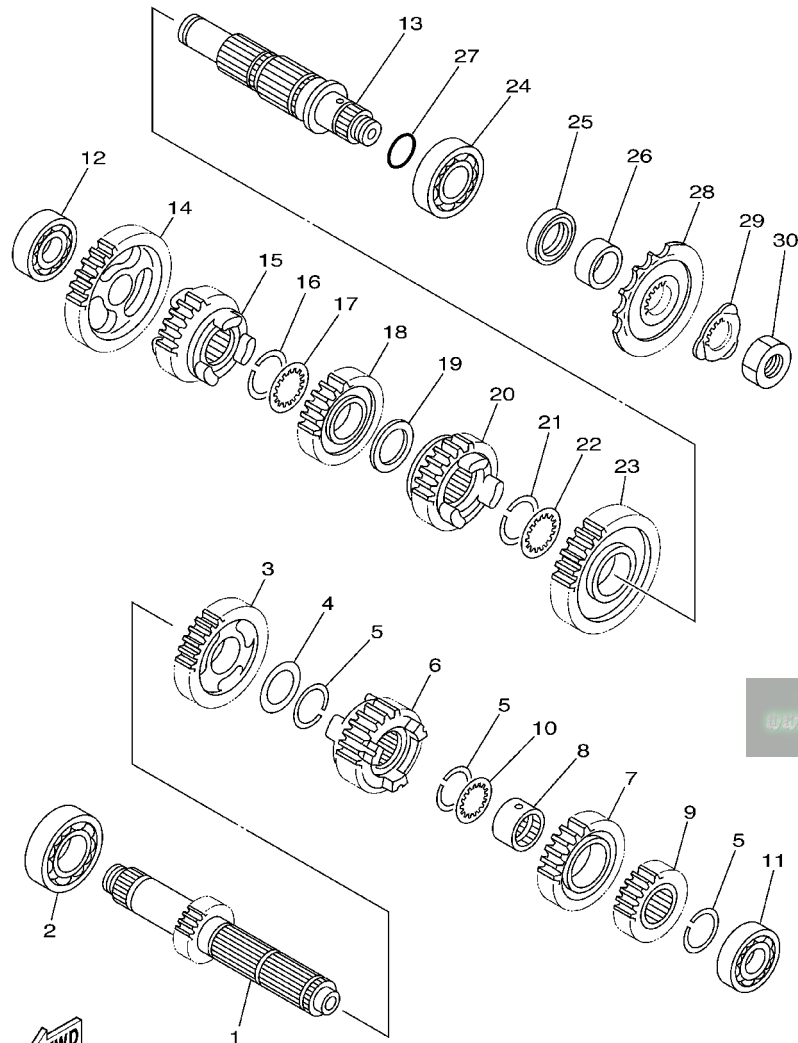

5CU1100-9130

REF. NO.	PART NO.	DESCRIPTION	5UP1	5UP2	5UP3	5UP4	REMARKS
1	5BE-17411-00	AXLE, MAIN	1	1	1	1	
2	93306-20540	BEARING	1	1	1	1	
3	5BE-17151-00	GEAR, 5TH PINION (21T)	1	1	1	1	
4	90201-253K0	WASHER, PLATE (T=1.0)	1	1	1	1	
5	93440-25084	CIRCLIP	3	3	3	3	
6	5CU-17131-00	GEAR, 3RD PINION (18T)	1	1	1	1	
7	5BE-17141-30	GEAR, 4TH PINION (22T)	1	1	1	1	
8	90387-2113G	COLLAR	1	1	1	1	
9	5JG-17121-10	GEAR, 2ND PINION (15T)	1	1	1	1	
10	90209-21332	WASHER	1	1	1	1	
11	93306-00442	BEARING	1	1	1	1	
12	93306-00426	BEARING	1	1	1	1	
13	5BE-17421-00	AXLE, DRIVE	1	1	1	1	
14	5BE-17211-00	GEAR, 1ST WHEEL (27T)	1	1	1	1	
15	5BE-17251-10	GEAR, 5TH WHEEL (20T)	1	1	1	1	
16	93440-25084	CIRCLIP	1	1	1	1	
17	90209-21332	WASHER	1	1	1	1	
18	5BE-17231-00	GEAR, 3RD WHEEL (23T)	1	1	1	1	
19	90201-253K0	WASHER, PLATE (T=1.0)	1	1	1	1	
20	5JG-17241-00	GEAR, 4TH WHEEL (24T)	1	1	1	1	
21	93440-28062	CIRCLIP	1	1	1	1	
22	90209-26348	WASHER	1	1	1	1	
23	5JG-17221-10	GEAR, 2ND WHEEL	1	1	1	1	
24	93306-20574	BEARING	1	1	1	1	
25	93102-32337	OIL SEAL	1	1	1	1	
26	90387-2515B	COLLAR	1	1	1	1	
27	93210-22298	O-RING	1	1	1	1	

FIG. 14 SHIFT CAM. FORK

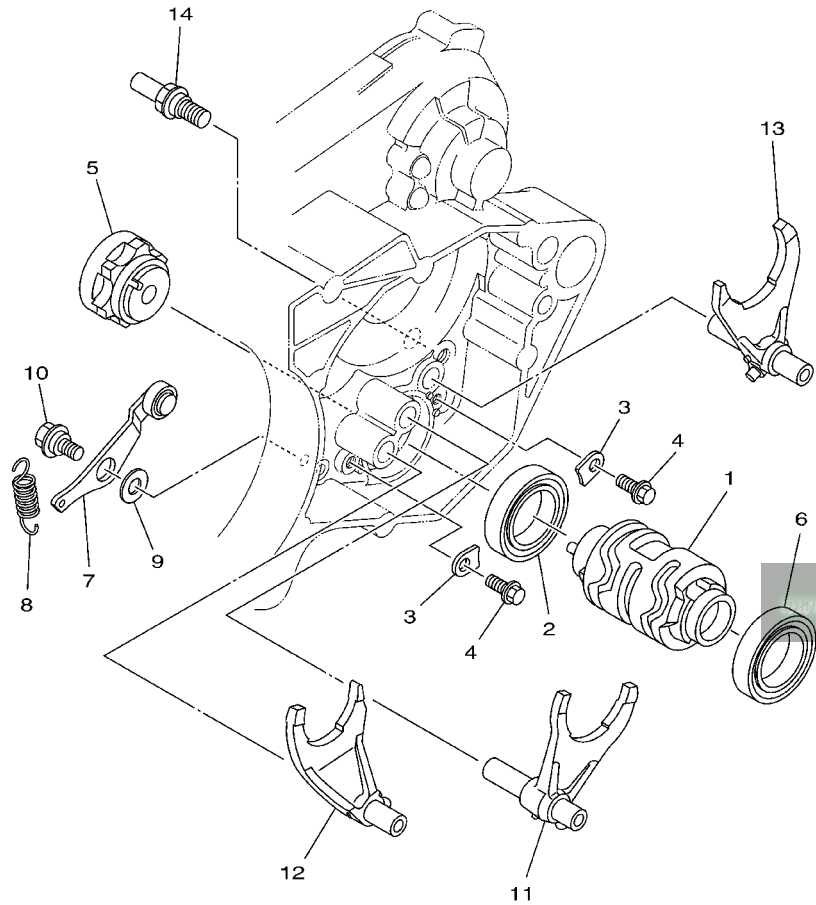

REF. NO.	PART NO.	DESCRIPTION	5UP1	5UP2	5UP3	5UP4	REMARKS
1	5MW-18541-00	CAM, SHIFT	1	1	1	1	
2	93306-90504	BEARING	1	1	1	1	
3	5DH-18562-00	PLATE, STOPPER 2	2	2	2	2	
4	90105-06553	BOLT, FLANGE	2	2	2	2	
5	4EW-18185-00	SEGMENT	1	1	1	1	
6	93306-90501	BEARING	1	1	1	1	
7	5CU-18140-01	STOPPER LEVER ASSY	1	1	1	1	
8	90507-14064	SPRING, TENSION	1	1	1	1	
9	90201-06013	WASHER, PLATE	1	1	1	1	
10	90109-063F8	BOLT	1	1	1	1	
11	5BE-18501-20	FORK, SHIFT 1	1	1	1	1	
12	5BE-18502-20	FORK, SHIFT 2	1	1	1	1	
13	5CU-18503-20	FORK, SHIFT 3	1	1	1	1	
14	4BR-18127-10	STOPPER, SCREW	1	1	1	1	



5MW1100-1140

FIG. 15 SHIFT SHAFT

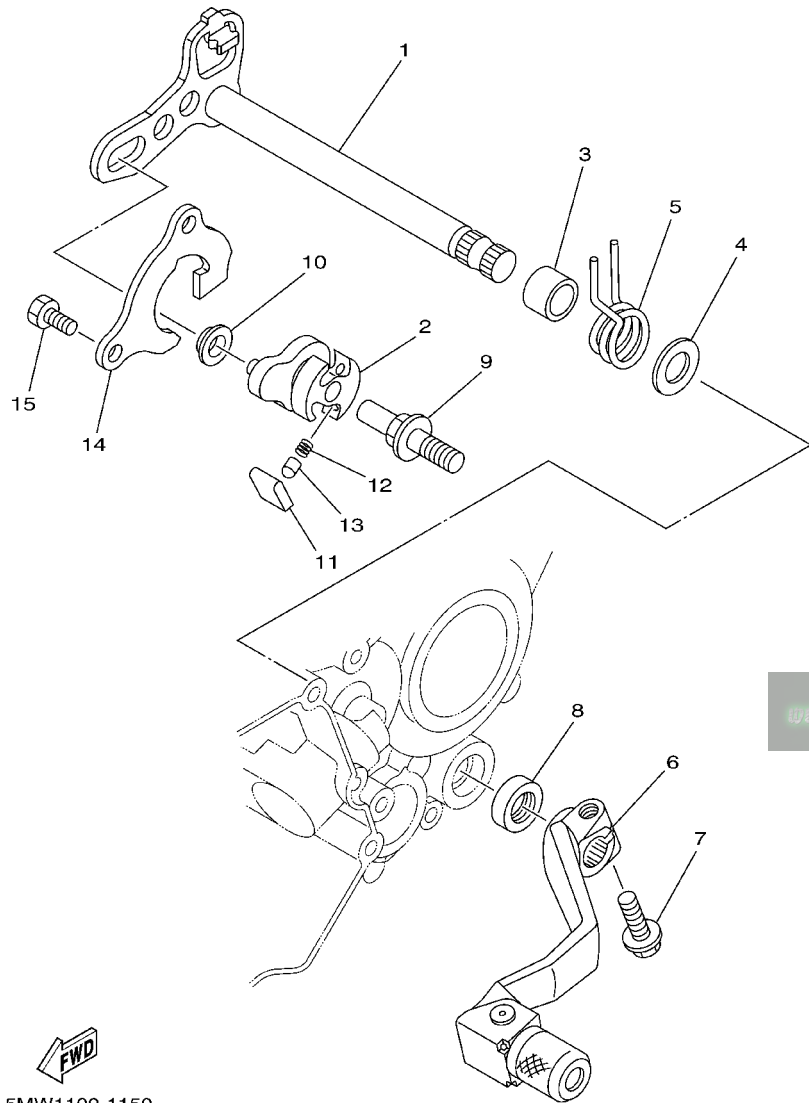

REF. NO.	PART NO.	DESCRIPTION	SUP1	SUP2	SUP3	SUP4	REMARKS
1	5CU-18101-10	SHIFT SHAFT ASSY	1	1	1	1	
2	5MW-18122-00	LEVER, SHIFT 2	1	1	1	1	
3	90387-124F4	COLLAR	1	1	1	1	
4	90201-12575	WASHER, PLATE	1	1	1	1	
5	90508-291A8	SPRING, TORSION	1	1	1	1	
6	5CU-18110-00	SHIFT PEDAL ASSY	1	1	1	1	
7	95027-06020	BOLT, FLANGE	1	1	1	1	
8	93102-12224	OIL SEAL	1	1	1	1	
9	3XJ-18173-00	PIN, SHIFT	1	1	1	1	
10	3XJ-18178-00	ROLLER, SHIFT LEVER	1	1	1	1	
11	3XJ-18182-00	PAWL, SHIFTER	2	2	2	2	
12	90501-052G5	SPRING, COMPRESSION	2	2	2	2	
13	3XJ-18184-00	PIN, PAWL	2	2	2	2	
14	5CU-18172-00	GUIDE, SHIFT	1	1	1	1	
15	90101-06664	BOLT	2	2	2	2	

www.legends-gamoha-enduros.com



5MW1100-1150

FIG. 16 FRAME

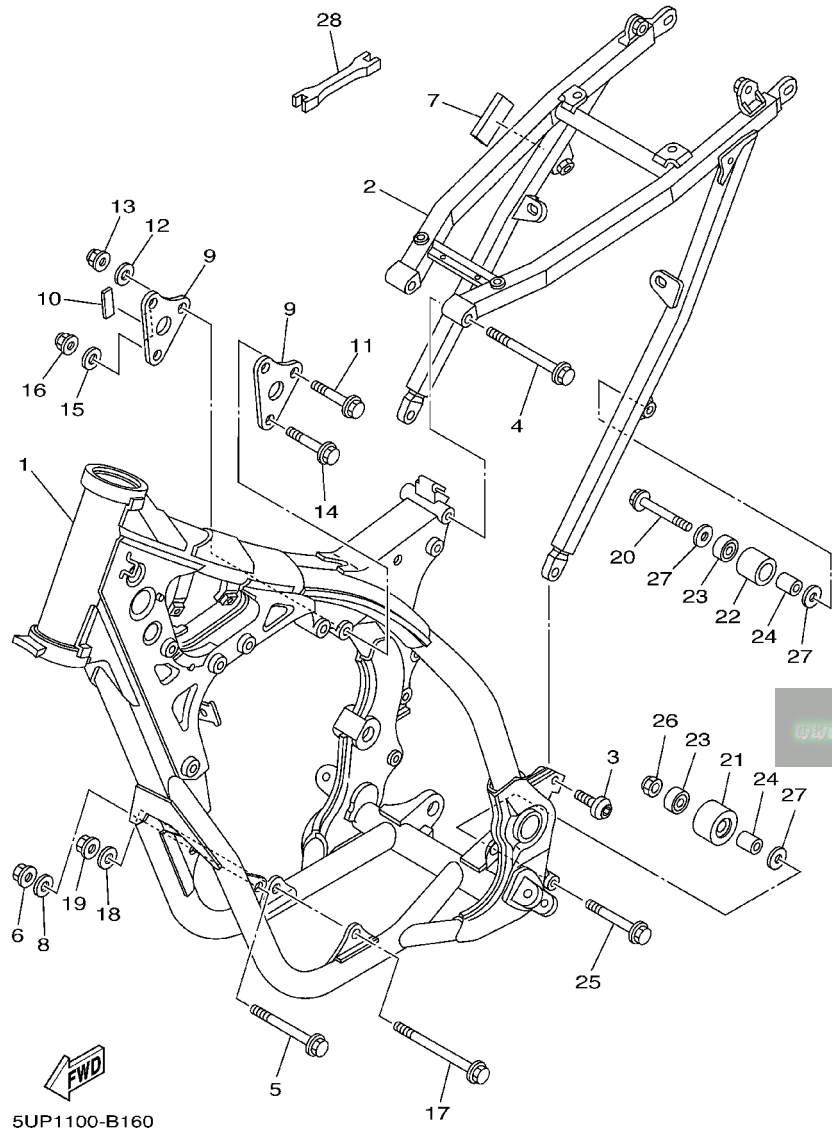

FWD
5UP1100-B160

REF. NO.	PART NO.	DESCRIPTION	5UP1	5UP2	5UP3	5UP4	REMARKS
1	5UP-21101-00	FRONT FRAME COMP.	1	1	1	1	
2	5UN-21190-00	REAR FRAME COMP.	1	1	1	1	
3	90110-08096	BOLT, HEXAGON SOCKET HEAD	2	2	2	2	
4	90105-08120	BOLT, FLANGE	1	1	1	1	
5	95817-10110	BOLT, FLANGE	1	1	1	1	
6	90185-10002	NUT, SELF-LOCKING	1	1	1	1	
7	5GJ-21717-00	DAMPER	1	1	1	1	
8	90201-10013	WASHER, PLATE	1	1	1	1	
9	5NX-21425-00	BRACKET, REAR UPPER 1	2	2	2	2	
10	4GG-21488-00	DAMPER	1	1	1	1	
11	90105-08494	BOLT, FLANGE	2	2	2	2	
12	90201-08730	WASHER, PLATE	4	4	4	4	
13	90185-08169	NUT, SELF-LOCKING	2	2	2	2	
14	95817-10050	BOLT, FLANGE	1	1	1	1	
15	92907-10200	WASHER, PLAIN	1	1	1	1	
16	90185-10002	NUT, SELF-LOCKING	1	1	1	1	
17	90105-10731	BOLT, FLANGE	1	1	1	1	
18	90201-10013	WASHER, PLATE	1	1	1	1	
19	90185-10002	NUT, SELF-LOCKING	1	1	1	1	
20	95027-08040	BOLT, FLANGE	1	1	1	1	
21	3JD-22178-10	TENSIONER	1	1	1	1	
22	4EW-22178-00	TENSIONER	1	1	1	1	
23	93300-60804	BEARING	2	2	2	2	
24	90387-086N4	COLLAR	2	2	2	2	
25	95027-08055	BOLT, FLANGE	1	1	1	1	
26	90185-08055	NUT, SELF-LOCKING	1	1	1	1	
27	90201-086P8	WASHER, PLATE	3	3	3	3	

FIG. 16 FRAME

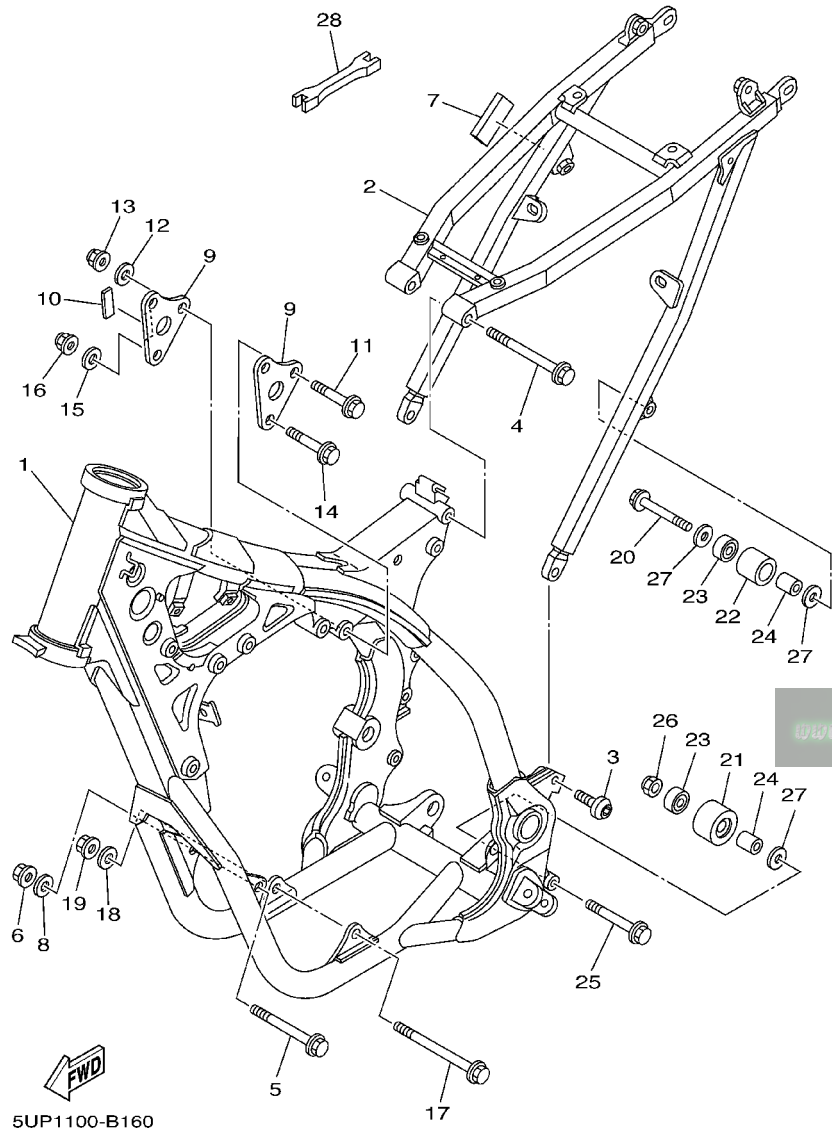

FWD
5UP1100-B160

REF. NO.	PART NO.	DESCRIPTION	5UP1	5UP2	5UP3	5UP4	REMARKS
28	5ET-28166-00	WRENCH, HEXAGON	1	1	1	1	

FIG. 17 FENDER

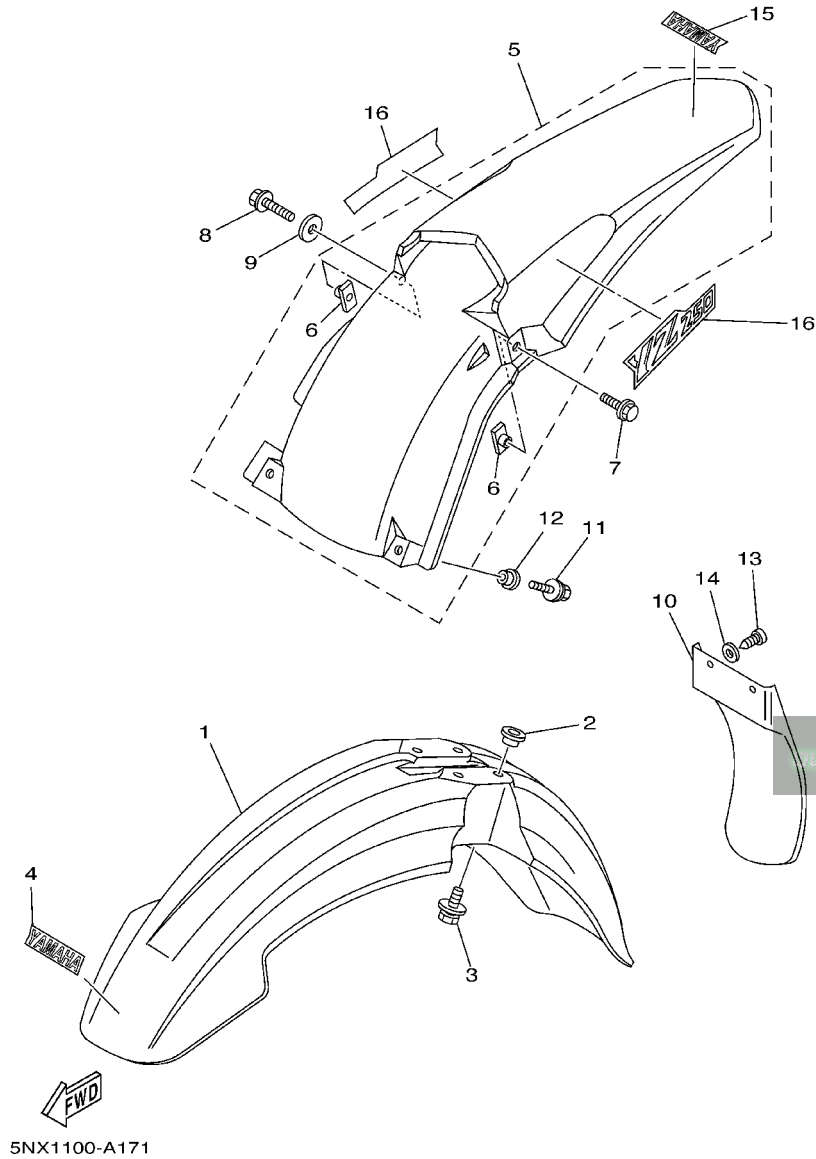

REF. NO.	PART NO.	DESCRIPTION	5UP1	5UP2	5UP3	5UP4	REMARKS
1	5HD-21511-00	FENDER, FRONT	1	1	1	1	
2	3JD-21748-00	COLLAR	4	4	4	4	
3	90119-06096	BOLT, WITH WASHER	4	4	4	4	
4	4ES-2153E-01	EMBLEM, YAMAHA	1	1	1	1	
5	5UN-21610-00	REAR FENDER COMP.	1	1	1	1	
6	5UN-21635-00	.NUT, REAR FENDER	2	2	2	2	
7	90119-06192	BOLT, WITH WASHER	1	1	1	1	
8	95027-06030	BOLT, FLANGE	1	1	1	1	
9	90201-06071	WASHER, PLATE	1	1	1	1	
10	5UN-21642-00	GUARD, FLAP	1	1	1	1	
11	90119-06225	BOLT, WITH WASHER	2	2	2	2	
12	90387-06009	COLLAR	2	2	2	2	
13	97707-60016	SCREW, TAPPING	2	2	2	2	
14	90201-06557	WASHER, PLATE	2	2	2	2	
15	4ES-2153E-01	EMBLEM, YAMAHA	1	1	1	1	
16	5NX-2163G-00	EMBLEM 1	2	2	2	2	

FIG. 18 SIDE COVER

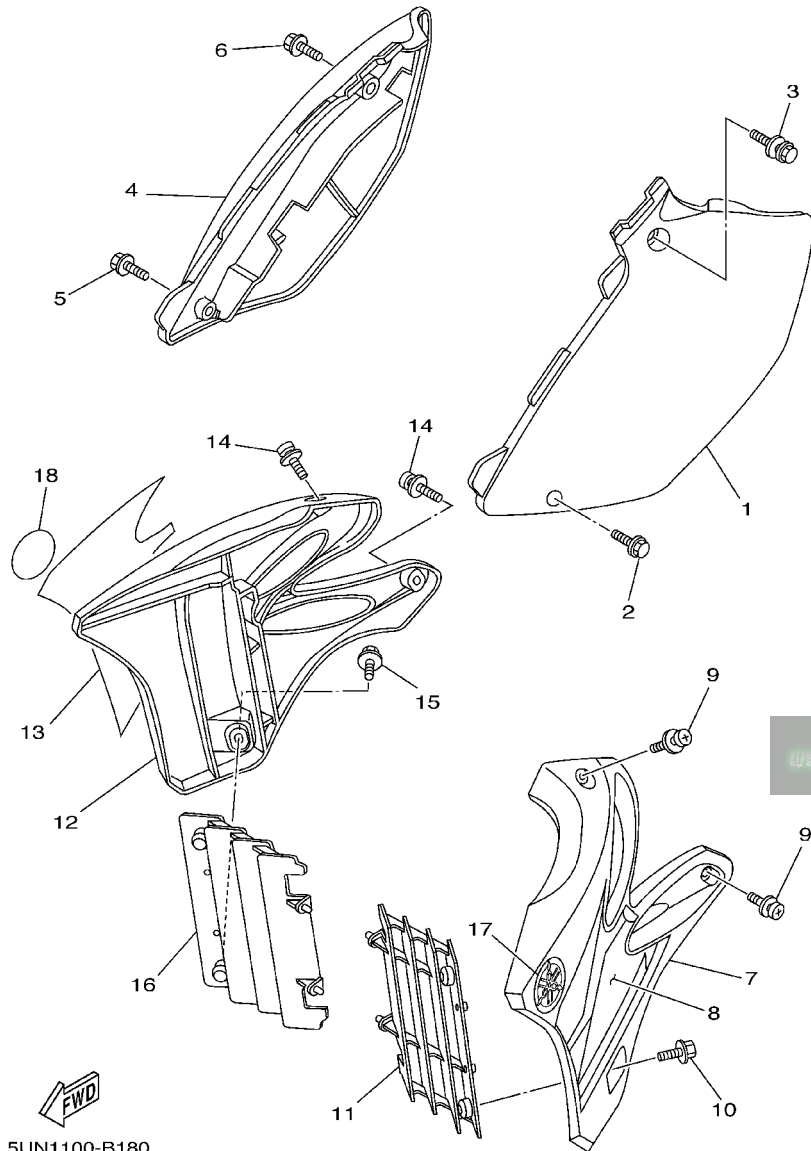

REF. NO.	PART NO.	DESCRIPTION	5UP1	5UP2	5UP3	5UP4	REMARKS
1	5NY-21711-00	COVER, SIDE 1	1	1	1	1	
2	95827-06016	BOLT, FLANGE	1	1	1	1	
3	90119-08238	BOLT, WITH WASHER	1	1	1	1	
4	5NY-21721-00	COVER, SIDE 2	1	1	1	1	
5	95827-06016	BOLT, FLANGE	1	1	1	1	
6	90119-08238	BOLT, WITH WASHER	1	1	1	1	
7	5NY-21730-00	SIDE COVER ASSY 3	1	1	1	1	
8	5UN-2173E-00	GRAPHIC 1	1	1	1	1	
9	90159-06182	SCREW, WITH WASHER	2	2	2	2	
10	90159-06078	SCREW, WITH WASHER	1	1	1	1	
11	5NL-2172A-10	PANEL 1	1	1	1	1	
12	5NY-21740-00	SIDE COVER ASSY 4	1	1	1	1	
13	5UN-2173F-00	GRAPHIC 2	1	1	1	1	
14	90159-06182	SCREW, WITH WASHER	2	2	2	2	
15	90159-06078	SCREW, WITH WASHER	1	1	1	1	
16	5NL-2172A-10	PANEL 1	1	1	1	1	
17	5MV-2175C-00	TUNING FORK MARK	1	1	1	1	
18	5MV-2175C-00	TUNING FORK MARK	1	1	1	1	

FIG. 19 REAR ARM

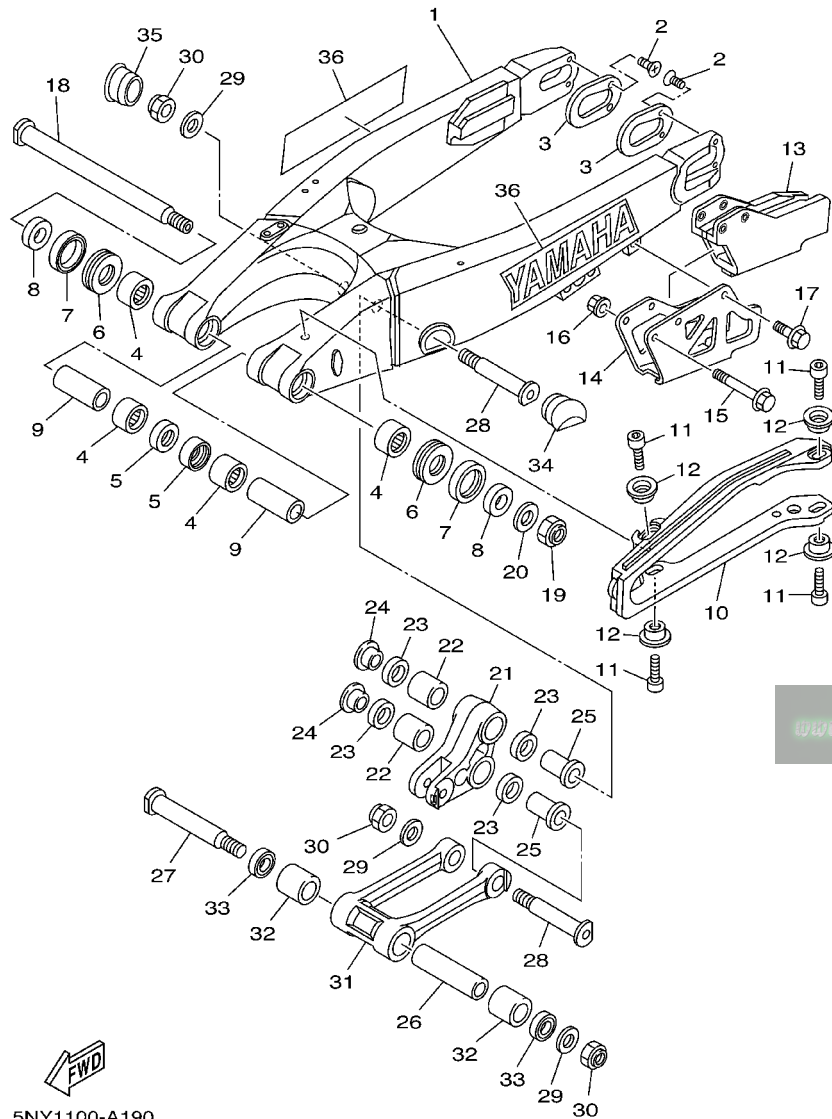

5NY1100-A190

REF. NO.	PART NO.	DESCRIPTION	SUP1	SUP2	SUP3	SUP4	REMARKS
1	5UN-22110-00	REAR ARM COMP.	1	1	1	1	
2	90151-04048	SCREW, COUNTERSUNK	4	4	4	4	
3	5UN-22355-00	PATCH	2	2	2	2	
4	93317-22262	BEARING	4	4	4	4	
5	93106-22019	OIL SEAL (DC 22-28-8)	2	2	2	2	
6	93342-22217	BEARING	2	2	2	2	
7	93109-28043	OIL SEAL	2	2	2	2	
8	90387-18005	COLLAR	2	2	2	2	
9	90387-18004	COLLAR	2	2	2	2	
10	5UN-22151-00	SEAL, GUARD	1	1	1	1	
11	91317-05008	BOLT	4	4	4	4	
12	5JG-22156-00	WASHER, PLATE	4	4	4	4	
13	5UN-22199-00	SUPPORT, CHAIN	1	1	1	1	
14	5UN-22128-00	COVER, THRUST 1	1	1	1	1	
15	95027-06050	BOLT, FLANGE	2	2	2	2	
16	90179-06568	NUT	2	2	2	2	
17	95027-06010	BOLT, FLANGE	1	1	1	1	
18	5NY-22141-01	SHAFT, PIVOT	1	1	1	1	
19	90185-16127	NUT, SELF-LOCKING	1	1	1	1	
20	90201-160F6	WASHER, PLATE	1	1	1	1	
21	5NY-2217A-00	ARM, RELAY	1	1	1	1	
22	93315-32056	BEARING	2	2	2	2	
23	93109-20076	OIL SEAL	4	4	4	4	
24	90387-16005	COLLAR	2	2	2	2	
25	90387-16007	COLLAR	2	2	2	2	
26	90387-167Y9	COLLAR	1	1	1	1	
27	5NY-22121-00	SHAFT 1	1	1	1	1	

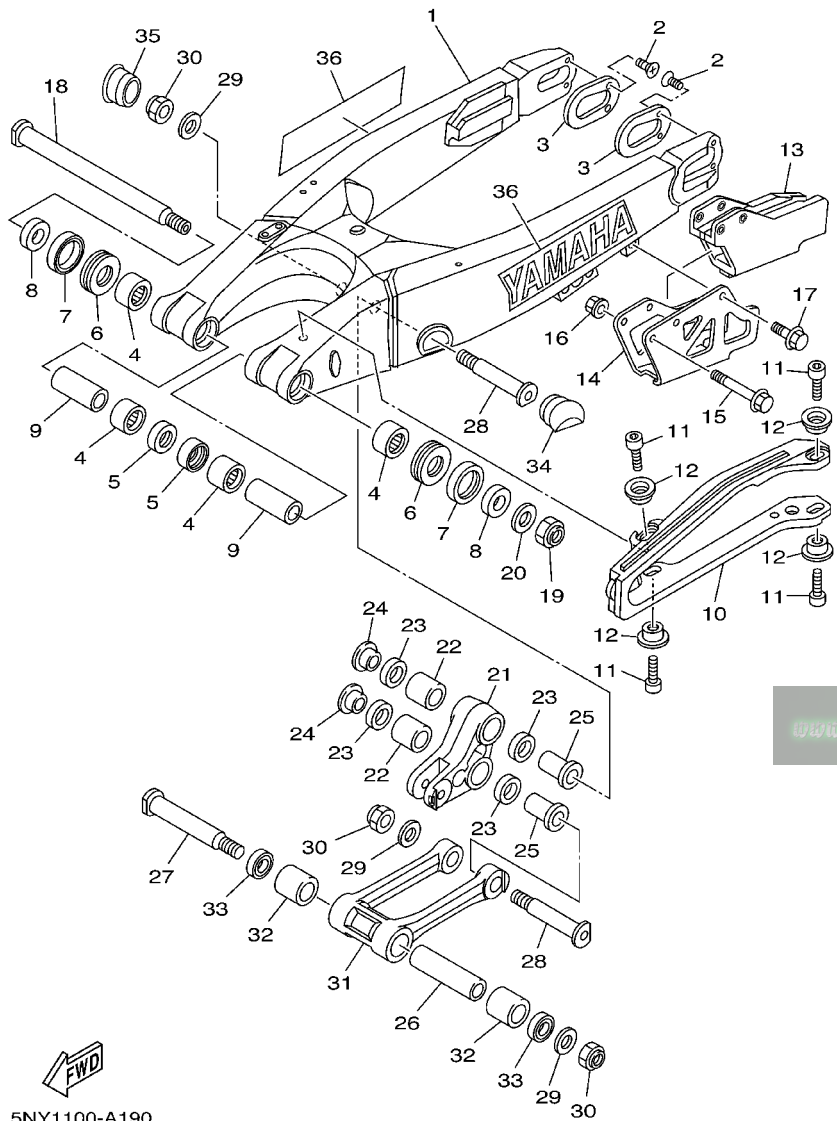

5NY1100-A190

FIG. 19 REAR ARM

REF. NO.	PART NO.	DESCRIPTION	5UP1	5UP2	5UP3	5UP4	REMARKS
28	5NY-22122-00	SHAFT 2	2	2	2	2	
29	90201-14740	WASHER, PLATE	3	3	3	3	
30	90185-14007	NUT, SELF-LOCKING	3	3	3	3	
31	5NY-2217F-00	ROD, CONNECTING 1	1	1	1	1	
32	93315-32053	BEARING	2	2	2	2	
33	93109-20076	OIL SEAL	2	2	2	2	
34	5NY-2135F-00	COVER	1	1	1	1	
35	5HD-2135F-00	COVER	1	1	1	1	
36	5UN-2153A-00	EMBLEM, YAMAHA	2	2	2	2	

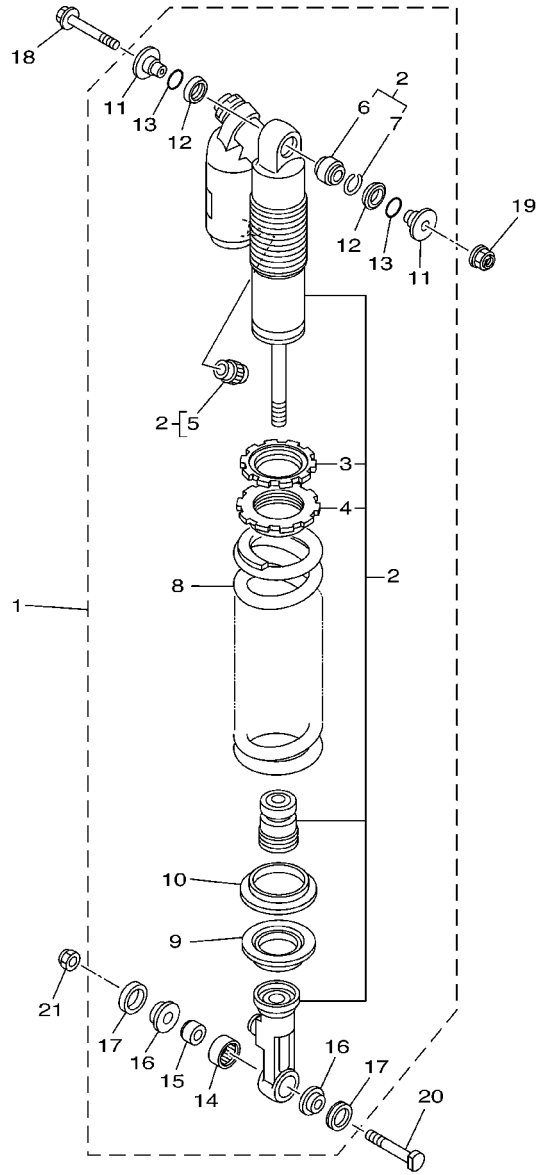

5NY1100-A200

FIG. 20 REAR SUSPENSION

REF. NO.	PART NO.	DESCRIPTION	5UP1	5UP2	5UP3	5UP4	REMARKS
1	5UP-22210-40	SHOCK ABSORBER ASSY, REAR	1			1	UR FOR ZAF
2	5UP-22201-40	.DAMPER SUB ASSY	1			1	UR FOR ZAF
3	3SP-22234-00	..GUIDE, SPRING 3	1	1	1	1	
4	3SP-22213-00	..SEAT, SPRING UPPER	1	1	1	1	
5	509-23184-L0	..CAP, AIR VALVE	1	1	1	1	
6	4JX-22226-00	..BUSH, SHOCK ABSORBER LOWER	1	1	1	1	
7	5DH-23183-00	..CIRCLIP	1	1	1	1	
8	5UN-22212-30	..SPRING (K=4.9)	1			1	
9	5DH-22214-00	..GUIDE, SPRING 1	1	1	1	1	
10	5MV-22224-00	..GUIDE, SPRING 2	1	1	1	1	
11	5DH-22253-00	..COLLAR, DISTANCE	2	2	2	2	
12	3JE-22475-00	..SEAL, DUST	2	2	2	2	
13	4EW-22474-00	..SEAL, RING	2	2	2	2	
14	5UN-22176-00	..BEARING	1	1	1	1	
15	5MV-22184-00	..BUSH	1	1	1	1	
16	5MV-22253-00	..COLLAR, DISTANCE	2	2	2	2	
17	5NY-22475-00	..SEAL, DUST	2	2	2	2	
18	90105-10323	BOLT, FLANGE	1	1	1	1	

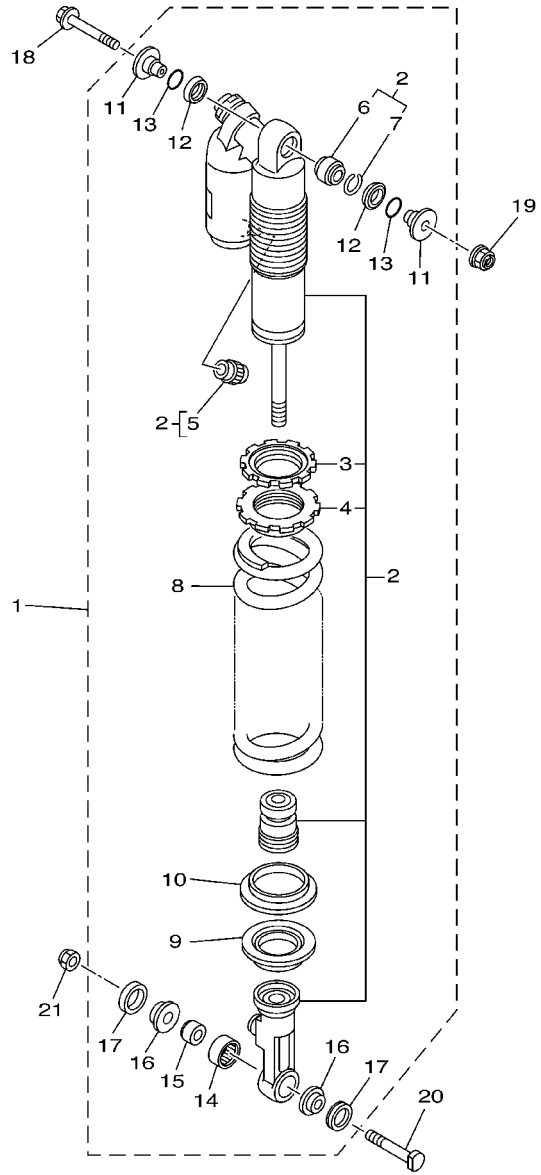



 5NY1100-A200

FIG. 20 REAR SUSPENSION

REF. NO.	PART NO.	DESCRIPTION	5UP1	5UP2	5UP3	5UP4	REMARKS
19	95607-10200	NUT, U FLANGE	1	1	1	1	
20	5NY-22241-00	BOLT 1	1	1	1	1	
21	90185-10060	NUT, SELF-LOCKING	1	1	1	1	

www.legends-gamoha-enduros.com

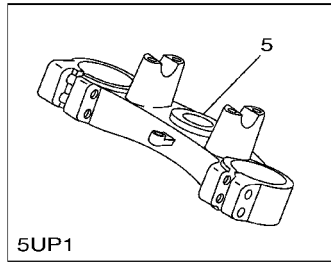
FIG. 21 STEERING



5UP1

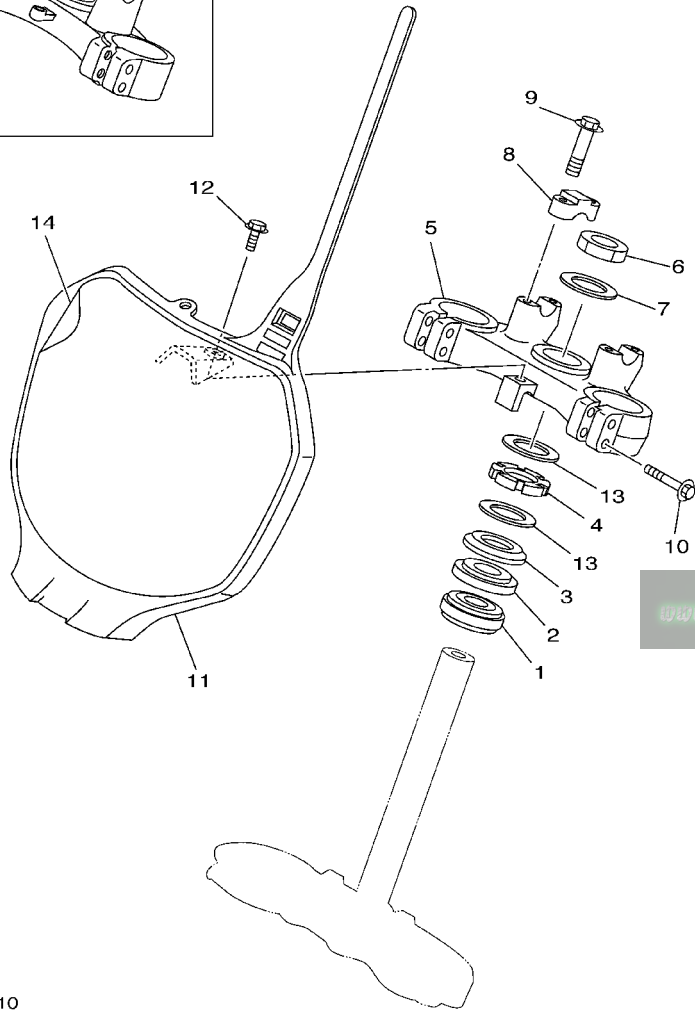

www.legends-gamaha-enduros.com

REF. NO.	PART NO.	DESCRIPTION	5UP1	5UP2	5UP3	5UP4	REMARKS
1	93332-00081	BEARING	1	1	1	1	
2	93332-00068	BEARING	1	1	1	1	
3	4EW-23416-00	COVER, BALL RACE 2	1	1	1	1	
4	90179-28650	NUT	1	1	1	1	
5	5NL-23435-00	CROWN, HANDLE	1				
6	90170-24373	NUT	1	1	1	1	
7	90201-247L2	WASHER, PLATE	1	1	1	1	
8	3SP-23441-00	HOLDER, HANDLE UPPER	2	2	2	2	
9	95027-08035	BOLT, FLANGE	4	4	4	4	
10	95027-08040	BOLT, FLANGE	4	4	4	4	
11	5HD-23485-00	PLATE, NUMBER	1	1	1	1	
12	95027-06014	BOLT, FLANGE	1	1	1	1	
13	90201-286K9	WASHER, PLATE	2	2	2	2	
14	5HD-2339E-00	GRAPHIC 1	1	1	1	1	



5UP1100-B210

FIG. 22 FRONT FORK

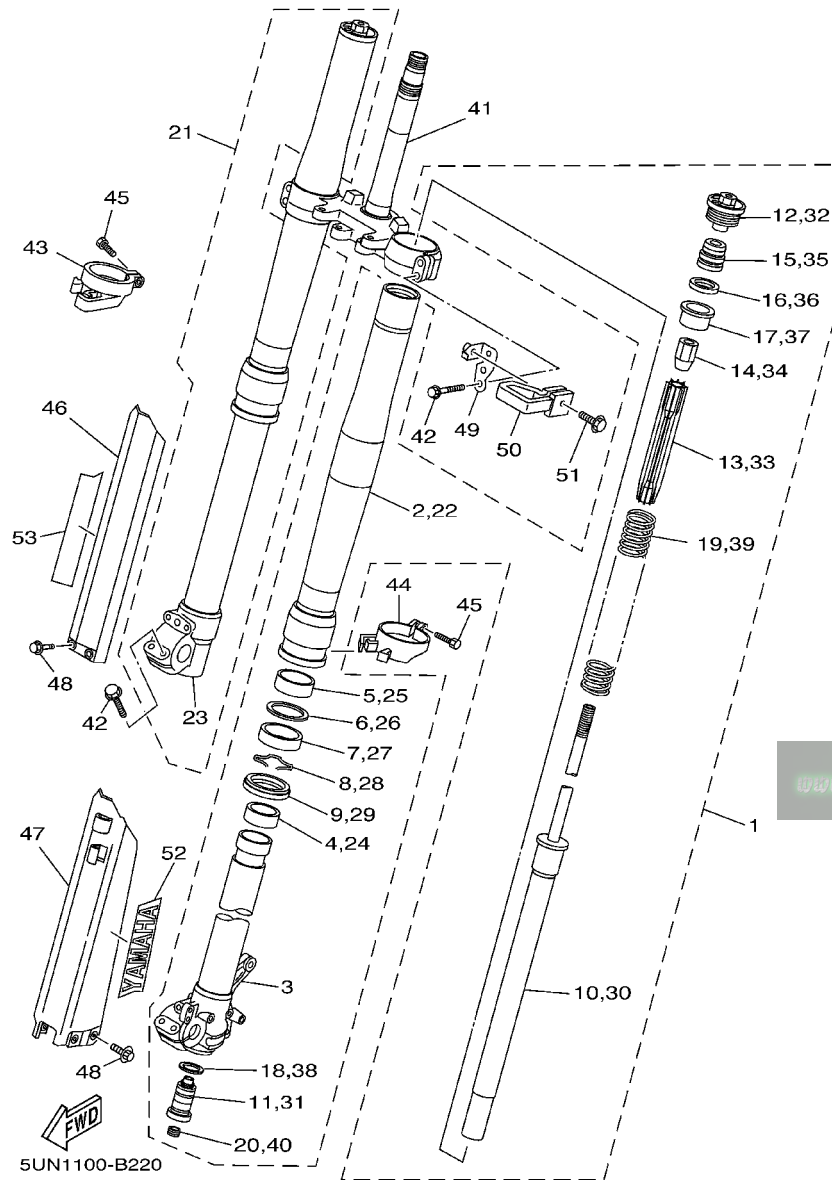

REF. NO.	PART NO.	DESCRIPTION	5UP1	5UP2	5UP3	5UP4	REMARKS
1	5UP-23102-00	FRONT FORK ASSY (L.H)	1			1	
2	5HD-23136-L0	.TUBE, OUTER (RIGHT)	1	1	1	1	
3	5DH-23120-L0	.INNER TUBE COMP.2	1	1	1	1	
4	5ET-23171-L0	.PISTON, FRONT FORK	1	1	1	1	
5	5ET-23125-L0	.METAL, SLIDE 1	1	1	1	1	
6	5UN-23146-L0	.WASHER, OIL SEAL	1	1	1	1	
7	5ET-23145-L0	.OIL SEAL	1	1	1	1	
8	4SS-23153-L0	.RING, SNAP	1	1	1	1	
9	5HD-23144-L0	.SEAL, DUST	1	1	1	1	
10	5UN-23170-L0	.CYLINDER COMP., FRONT FORK	1	1	1	1	
11	5UP-2316A-00	.VALVE COMP.	1			1	
12	5UN-23111-L0	.BOLT, CAP	1	1	1	1	
13	5DH-23142-L0	.SEAT, SPRING UPPER	1	1	1	1	
14	5HD-23393-L0	.NUT, SPECIAL	1	1	1	1	
15	5MV-23195-L0	.RUBBER	1	1	1	1	
16	5DH-23149-L0	.WASHER, SPRING UPPER	1	1	1	1	
17	5DH-23118-L0	.SPACER	1	1	1	1	
18	4SS-23158-L0	.GASKET	1	1	1	1	
19	4XL-23141-L0	.SPRING, FRONT FORK (K=0.43)	1			1	
20	3JD-2312G-L0	.PLUG	1	1	1	1	
21	5UP-23103-00	FRONT FORK ASSY (R.H)	1			1	

FIG. 22 FRONT FORK

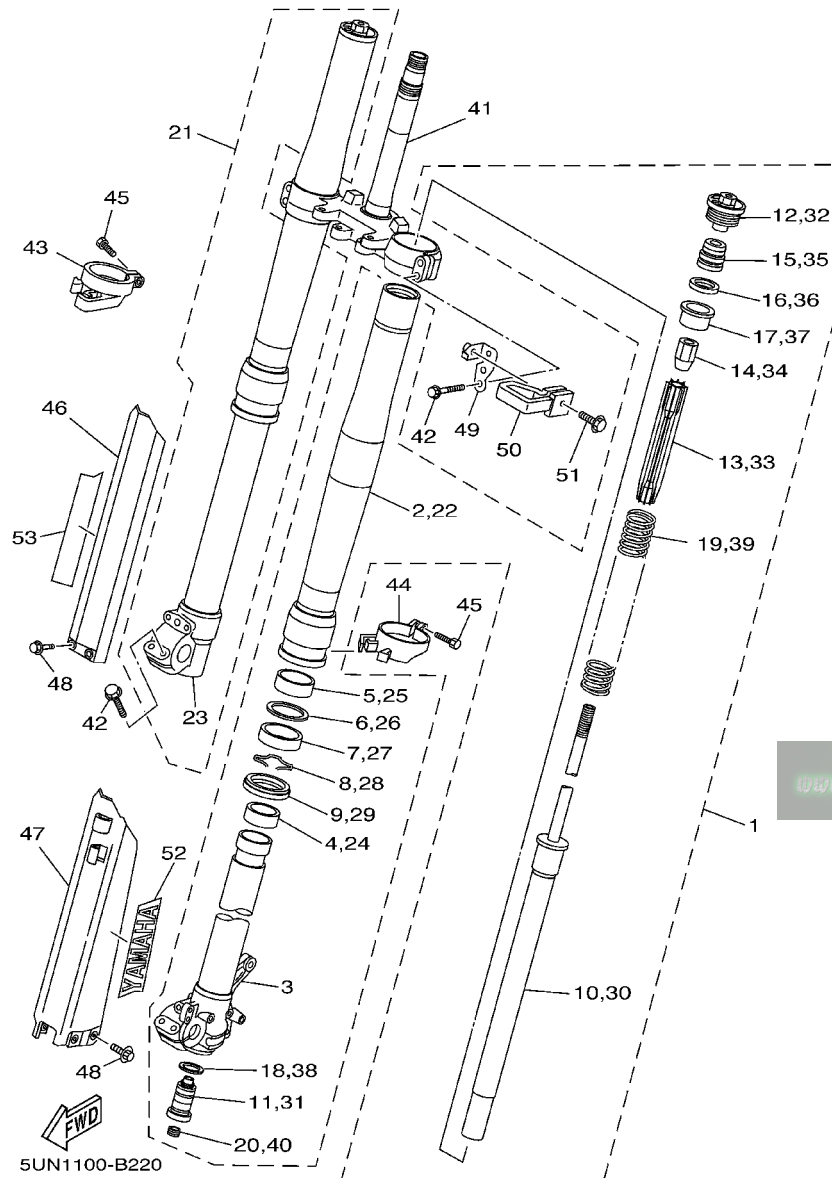

REF. NO.	PART NO.	DESCRIPTION	5UP1	5UP2	5UP3	5UP4	REMARKS
22	5HD-23136-L0	.TUBE, OUTER (RIGHT)	1	1	1	1	
23	5BF-23110-L0	.INNER TUBE COMP.1	1	1	1	1	
24	5ET-23171-L0	.PISTON, FRONT FORK	1	1	1	1	
25	5ET-23125-L0	.METAL, SLIDE 1	1	1	1	1	
26	5UN-23146-L0	.WASHER, OIL SEAL	1	1	1	1	
27	5ET-23145-L0	.OIL SEAL	1	1	1	1	
28	4SS-23153-L0	.RING, SNAP	1	1	1	1	
29	5HD-23144-L0	.SEAL, DUST	1	1	1	1	
30	5UN-23170-L0	.CYLINDER COMP., FRONT FORK	1	1	1	1	
31	5UP-2316A-00	.VALVE COMP.	1			1	
32	5UN-23111-L0	.BOLT, CAP	1	1	1	1	
33	5DH-23142-L0	.SEAT, SPRING UPPER	1	1	1	1	
34	5HD-23393-L0	.NUT, SPECIAL	1	1	1	1	
35	5MV-23195-L0	.RUBBER	1	1	1	1	
36	5DH-23149-L0	.WASHER, SPRING UPPER	1	1	1	1	
37	5DH-23118-L0	.SPACER	1	1	1	1	
38	4SS-23158-L0	.GASKET	1	1	1	1	
39	4XL-23141-L0	.SPRING, FRONT FORK (K=0.43)	1			1	
40	3JD-2312G-L0	.PLUG	1	1	1	1	
41	5UP-23340-L0	UNDER BRACKET COMP.	1	1	1	1	
42	5NY-23346-L0	BOLT 1	8	8	8	8	

FIG. 22 FRONT FORK

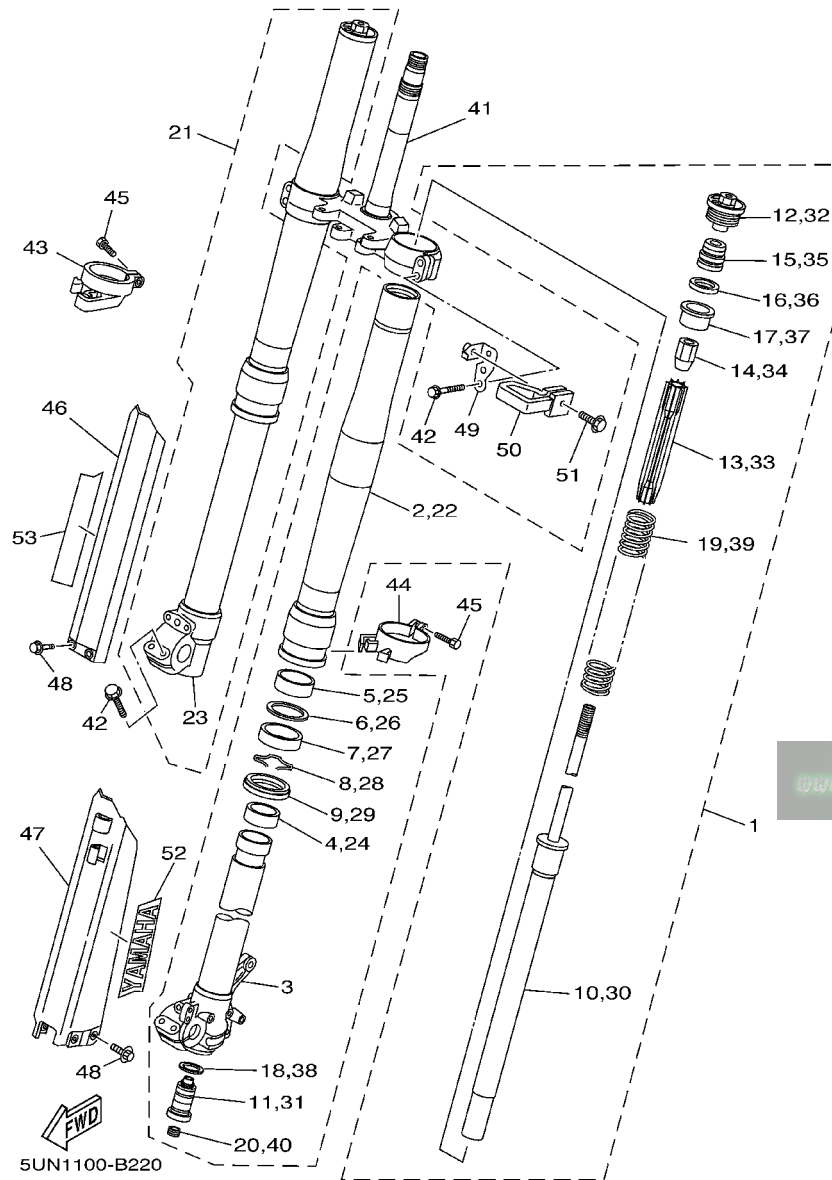

REF. NO.	PART NO.	DESCRIPTION	5UP1	5UP2	5UP3	5UP4	REMARKS
43	4SS-2314G-L0	PROTECTOR GUIDE COMP., 2	1	1	1	1	
44	5DH-2314F-L0	PROTECTOR GUIDE COMP., 1	1	1	1	1	
45	4SS-23346-L0	BOLT 1	2	2	2	2	
46	5DH-2314J-00	PROTECTOR COMP., 2	1	1	1	1	
47	5DH-2314H-00	PROTECTOR COMP., 1	1	1	1	1	
48	3SP-23356-L0	BOLT 2	6	6	6	6	
49	5HC-2331E-00	GUIDE, CABLE	1	1	1	1	
50	4DA-23389-00	GUIDE, CABLE	1	1	1	1	
51	90119-05071	BOLT, WITH WASHER	1	1	1	1	
52	4XL-2153A-10	EMBLEM, YAMAHA	1	1	1	1	
53	4XL-2153A-10	EMBLEM, YAMAHA	1	1	1	1	

FIG. 23 FUEL TANK

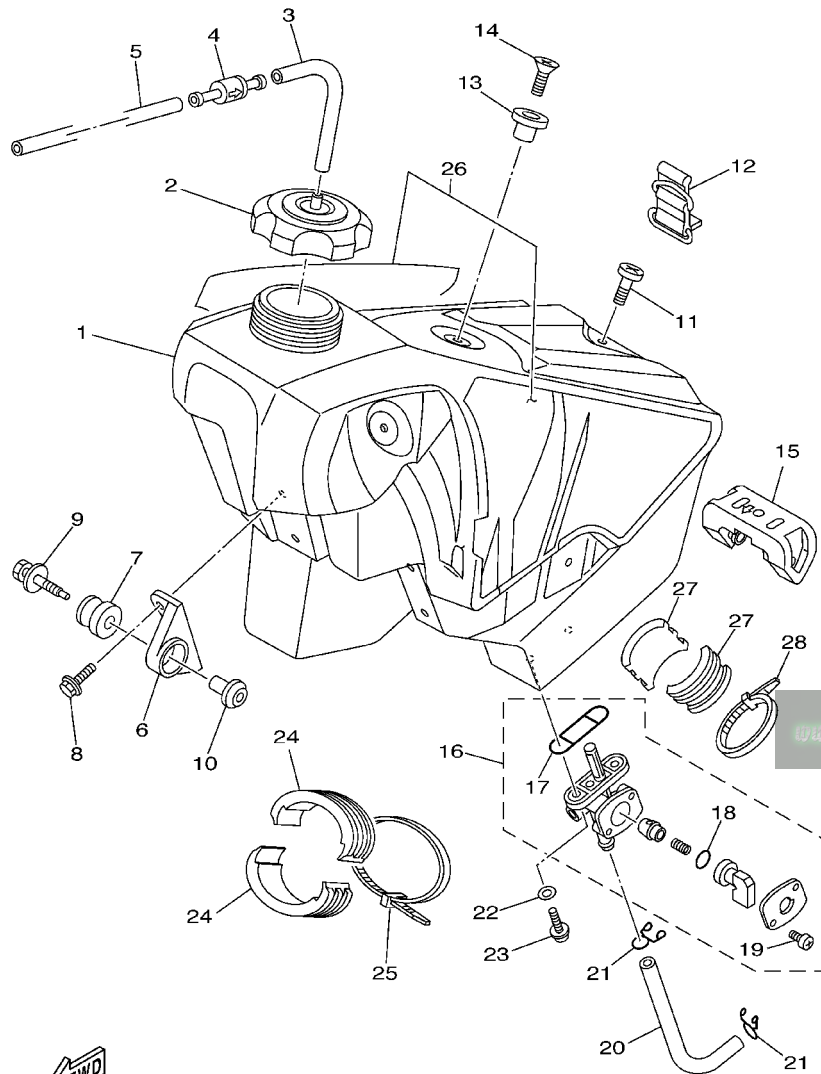

5UN1100-B230

REF. NO.	PART NO.	DESCRIPTION	5UP1	5UP2	5UP3	5UP4	REMARKS
1	5NY-24110-00	FUEL TANK COMP.	1	1	1	1	
2	5UN-24610-00	CAP ASSY	1	1	1	1	
3	90445-09220	HOSE	1	1	1	1	
4	3XJ-24380-00	PIPE JOINT ASSY	1	1	1	1	
5	90445-09104	HOSE	1	1	1	1	
6	24X-24144-00	HOLDER, DAMPER	2	2	2	2	
7	90480-18549	GROMMET	2	2	2	2	
8	95027-06016	BOLT, FLANGE	4	4	4	4	
9	90119-06214	BOLT, WITH WASHER	2	2	2	2	
10	5NY-24186-00	WASHER, SPECIAL	2	2	2	2	
11	98907-06025	SCREW, BIND	1	1	1	1	
12	3SP-24173-00	BAND, TANK FITTING 1	1	1	1	1	
13	4EW-2412F-00	BRACKET, SEAT	1	1	1	1	
14	98707-06025	SCREW, FLAT HEAD	1	1	1	1	
15	4SS-24181-00	DAMPER, LOCATING 1	1	1	1	1	
16	3JD-24500-01	FUEL COCK ASSY 1	1	1	1	1	
17	4X8-24512-00	.O-RING	1	1	1	1	
18	3AJ-24534-00	.SEAL, COCK	1	1	1	1	
19	97801-03008	.SCREW, PAN HEAD	2	2	2	2	
20	90445-111J0	HOSE (L145)	1	1	1	1	
21	90467-10008	CLIP	2	2	2	2	
22	90202-05193	WASHER, PLATE	2	2	2	2	
23	90149-06011	SCREW	2	2	2	2	
24	5NY-24182-00	DAMPER, LOCATING 2	2	2	2	2	
25	90465-13275	CLAMP	2	2	2	2	
26	5UN-24240-00	GRAPHIC SET	1	1	1	1	
27	5NY-24183-10	DAMPER, LOCATING 3	2	2	2	2	

FIG. 23 FUEL TANK

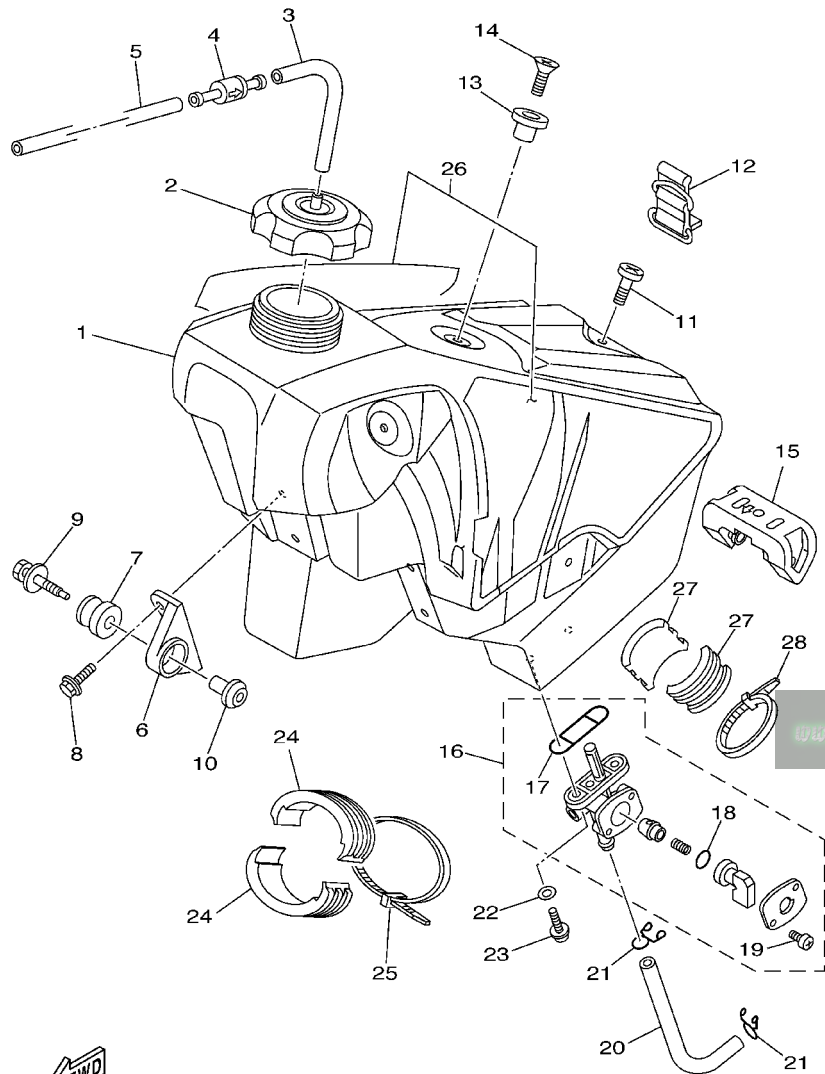

REF. NO.	PART NO.	DESCRIPTION	5UP1	5UP2	5UP3	5UP4	REMARKS
28	90465-13152	CLAMP	2	2	2	2	

www.legends-gamaha-enduros.com



5UN1100-B230

FIG. 24 SEAT

REF. NO.	PART NO.	DESCRIPTION	5UP1	5UP2	5UP3	5UP4	REMARKS
1	5NY-24770-00	SEMI-DOUBLE SEAT ASSY	1	1	1	1	
2	5NY-2470F-00	.SEAT COVER COMP.	1	1	1	1	
3	5NY-24728-00	.BRACKET, SEAT	2	2	2	2	
4	97307-06012	.BOLT	4	4	4	4	
5	92907-06100	.WASHER, SPRING	4	4	4	4	

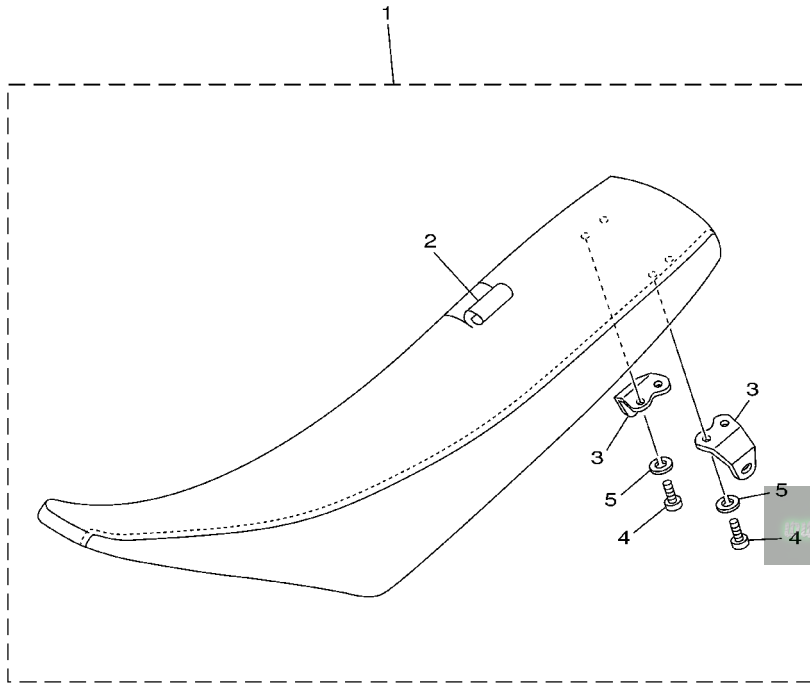

www.legends-gamaha-enduros.com



5NY1100-A240

D9

FIG. 25 FRONT WHEEL

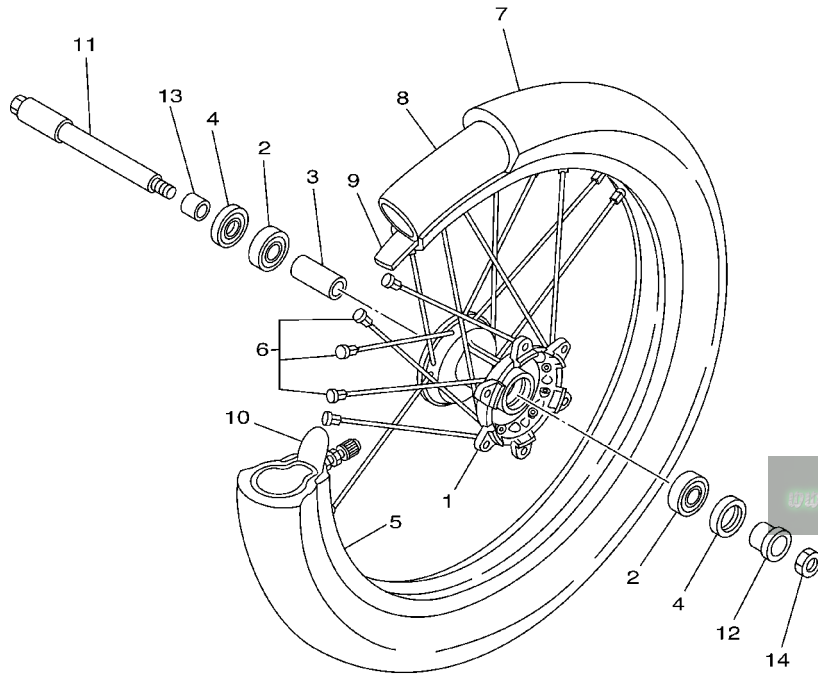

REF. NO.	PART NO.	DESCRIPTION	5UP1	5UP2	5UP3	5UP4	REMARKS
1	5NY-25111-00	HUB, FRONT	1	1	1	1	
2	93306-90403	BEARING	2	2	2	2	
3	5NY-25117-00	SPACER, BEARING	1	1	1	1	
4	93102-26468	OIL SEAL	2	2	2	2	
5	94416-21003	RIM (1.60-21)	1	1	1	1	
6	5NY-25104-00	SPOKE SET, FRONT	1	1	1	1	
7	L.M.	TIRE (80/100-21)	1			1	
8	L.M.	TUBE (80/100-21)	1	1		1	
9	94309-21161	BAND, RIM (1.60-21)	1	1		1	
10	5SF-25394-00	SPACER, BEAD	1	1	1	1	
11	5BE-25181-00	AXLE, WHEEL	1	1	1	1	
12	5NY-25183-00	COLLAR, WHEEL	1	1	1	1	
13	5NY-25186-00	COLLAR, WHEEL	1	1	1	1	
14	90179-16672	NUT	1	1	1	1	

www.legends-yamaha-enduros.com



5NY1100-A250

FIG. 26 FRONT BRAKE CALIPER

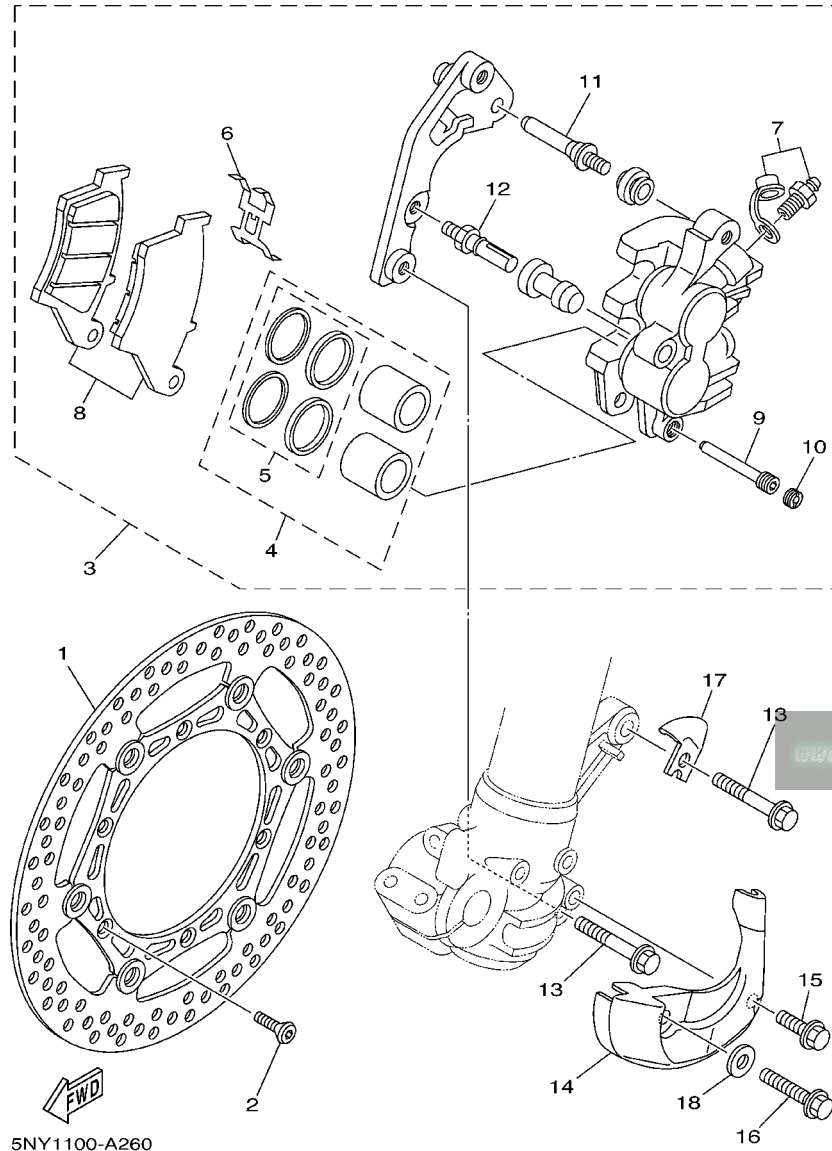

REF. NO.	PART NO.	DESCRIPTION	SUP1	SUP2	SUP3	SUP4	REMARKS
1	5MV-2581T-00	DISC BRAKE ASSY	1	1	1	1	
2	90149-06327	SCREW	6	6	6	6	
3	5UN-2580T-00	CALIPER ASSY (LEFT)	1	1	1	1	
4	5UN-W0057-00	.PISTON ASSY, CALIPER	1	1	1	1	
5	3JD-W0047-00	..CALIPER SEAL KIT	1	1	1	1	
6	5DH-25919-00	.SUPPORT, PAD	1	1	1	1	
7	1UY-W0048-50	.BLEED SCREW KIT	1	1	1	1	
8	5MV-W0045-01	.BRAKE PAD KIT	1	1	1	1	
9	5DH-25933-00	.PIN, PAD	1	1	1	1	
10	5DH-25916-00	.PLUG	1	1	1	1	
11	3SP-25926-51	.BOLT	1	1	1	1	
12	3SP-25914-51	.PIN, SLIDE	1	1	1	1	
13	90105-08659	BOLT, FLANGE	2	2	2	2	
14	5DH-2314E-00	COVER, HOSE	1	1	1	1	
15	95827-06012	BOLT, FLANGE	1	1	1	1	
16	95027-08020	BOLT, FLANGE	1	1	1	1	
17	5DH-25875-00	HOLDER, BRAKE HOSE 1	1	1	1	1	
18	92907-08200	WASHER	1	1	1	1	

FIG. 27 REAR WHEEL

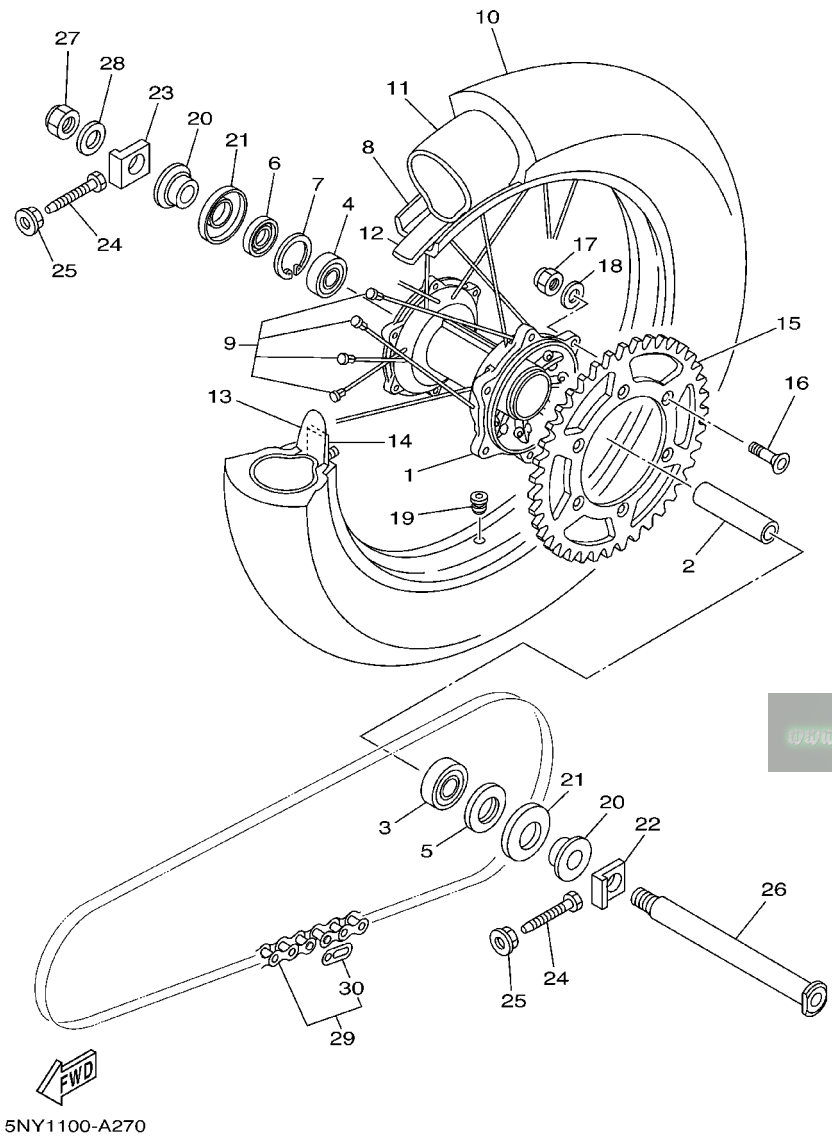

REF. NO.	PART NO.	DESCRIPTION	SUP1	SUP2	SUP3	SUP4	REMARKS
1	5ET-25311-00	HUB, REAR	1	1	1	1	
2	5ET-25317-00	SPACER, BEARING	1	1	1	1	
3	93306-27205	BEARING	1	1	1	1	
4	93306-07202	BEARING	1	1	1	1	
5	93106-30044	OIL SEAL	1	1	1	1	
6	93106-30045	OIL SEAL	1	1	1	1	
7	99009-45500	CIRCLIP	1	1	1	1	
8	94421-19602	RIM (2.15-19)	1	1	1	1	
9	5HD-25304-00	SPOKE SET, REAR	1	1	1	1	
10	L.M.	TIRE (110/90-19)	1			1	
11	L.M.	TUBE (110/90-19)	1	1		1	
12	94311-19155	BAND, RIM (2.15-19)	1	1		1	
13	3JE-25394-00	SPACER, BEAD	1	1	1	1	
14	4XM-25364-00	DAMPER	1	1	1	1	
15	5NY-25449-00	SPROCKET, DRIVEN (49T)	1	1			UR STD
	5NY-25450-00	SPROCKET, DRIVEN (50T)	1		1	1	UR
	5ET-25447-00	SPROCKET, DRIVEN (47T)	1	1	1	1	AP
	5NY-25448-00	SPROCKET, DRIVEN (48T)	1	1	1	1	AP
	5NY-25449-00	SPROCKET, DRIVEN (49T)	1		1	1	AP
	5NY-25450-00	SPROCKET, DRIVEN (50T)		1			AP
	5NY-25451-00	SPROCKET, DRIVEN (51T)	1	1	1	1	AP
	5NY-25452-00	SPROCKET, DRIVEN (52T)	1	1	1	1	AP
16	90109-081G1	BOLT	6	6	6	6	

FIG. 27 REAR WHEEL

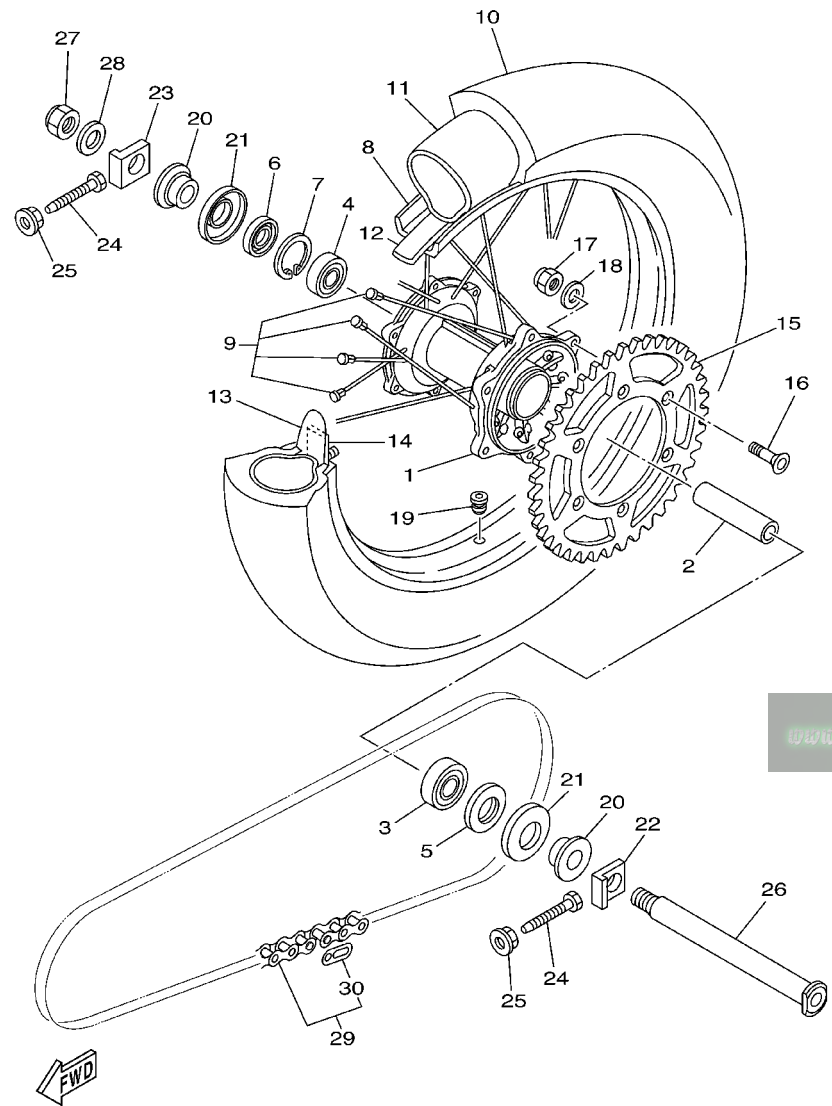

5NY1100-A270

REF. NO.	PART NO.	DESCRIPTION	5UP1	5UP2	5UP3	5UP4	REMARKS
17	90185-08169	NUT, SELF-LOCKING	6	6	6	6	
18	90201-08326	WASHER, PLATE	6	6	6	6	
19	90480-08608	GROMMET	1	1	1	1	
20	5UN-25383-00	COLLAR, WHEEL	2	2	2	2	
21	5ET-25367-00	COVER, HUB DUST	2	2	2	2	
22	5NY-25388-00	PULLER, CHAIN 1	1	1	1	1	
23	5NY-25389-00	PULLER, CHAIN 2	1	1	1	1	
24	90101-08777	BOLT	2	2	2	2	
25	95707-08500	NUT, FLANGE	2	2	2	2	
26	5ET-25381-00	AXLE, WHEEL	1	1	1	1	
27	90185-20168	NUT, SELF-LOCKING	1	1	1	1	
28	90201-203U1	WASHER, PLATE	1	1	1	1	
29	9Y581-92113	CHAIN (DID 520D 114L)	1	1	1	1	
30	94681-68001	.JOINT,CHAIN (DID 520DM-RJ)	1	1	1	1	

FIG. 28 REAR BRAKE CALIPER

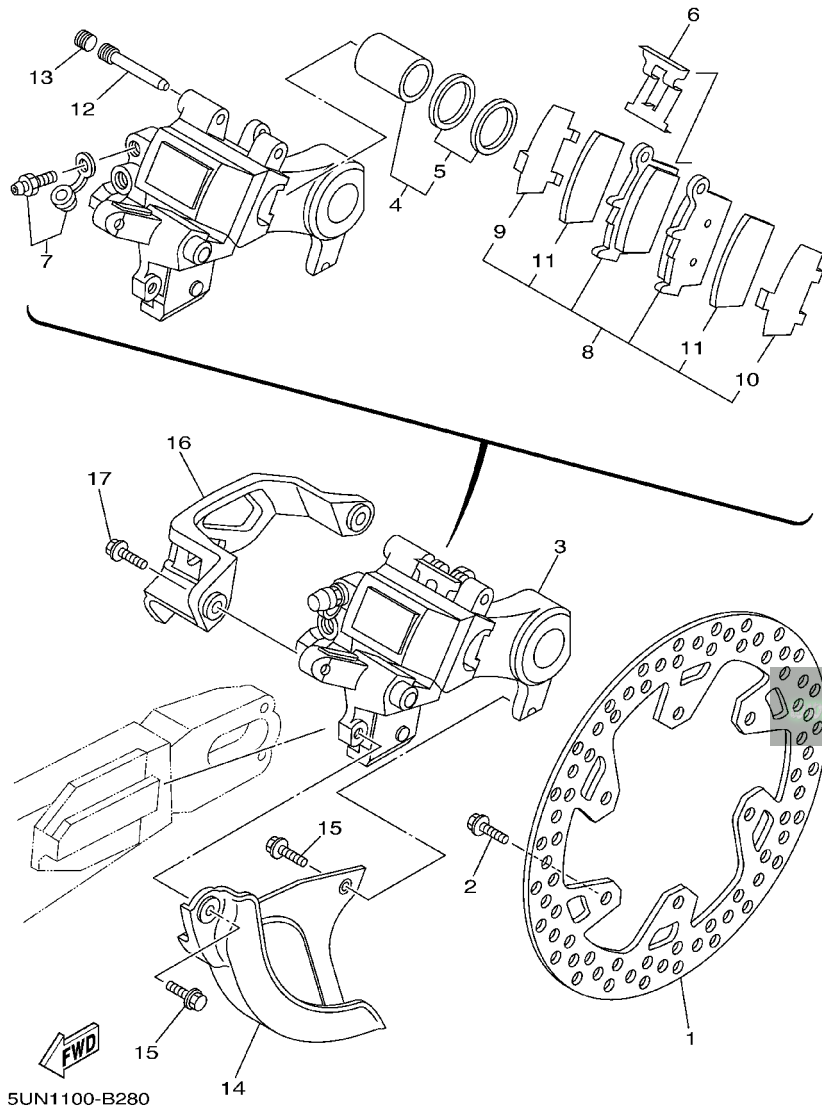

REF. NO.	PART NO.	DESCRIPTION	SUP1	SUP2	SUP3	SUP4	REMARKS
1	5NY-2582W-00	DISC, REAR BRAKE 2	1	1	1	1	
2	90109-065G4	BOLT	6	6	6	6	
3	5UN-2580W-00	CALIPER ASSY, REAR 2	1	1	1	1	
4	5UN-W0057-50	.PISTON ASSY, CALIPER	1	1	1	1	
5	5UN-W0047-50	..CALIPER SEAL KIT	1	1	1	1	
6	5DH-25919-50	..SUPPORT, PAD	1	1	1	1	
7	1UY-W0048-50	..BLEED SCREW KIT	1	1	1	1	
8	5UN-W0046-00	..BRAKE PAD KIT 2	1	1	1	1	
9	5UN-25828-50	..SHIM, CALIPER	1	1	1	1	
10	5UN-25827-50	..SHIM, CALIPER	1	1	1	1	
11	5UN-22898-50	..INSULATOR, HEAT	2	2	2	2	
12	8CR-25924-00	..PIN, PAD	1	1	1	1	
13	5DH-25916-00	..PLUG	1	1	1	1	
14	5DH-25718-01	PROTECTOR, DISK BRAKE	1	1	1	1	
15	95027-06012	BOLT, FLANGE	2	2	2	2	
16	5UN-27491-00	PROTECTOR	1	1	1	1	
17	95027-06016	BOLT, FLANGE	2	2	2	2	

FIG. 29 STEERING HANDLE. CABLE

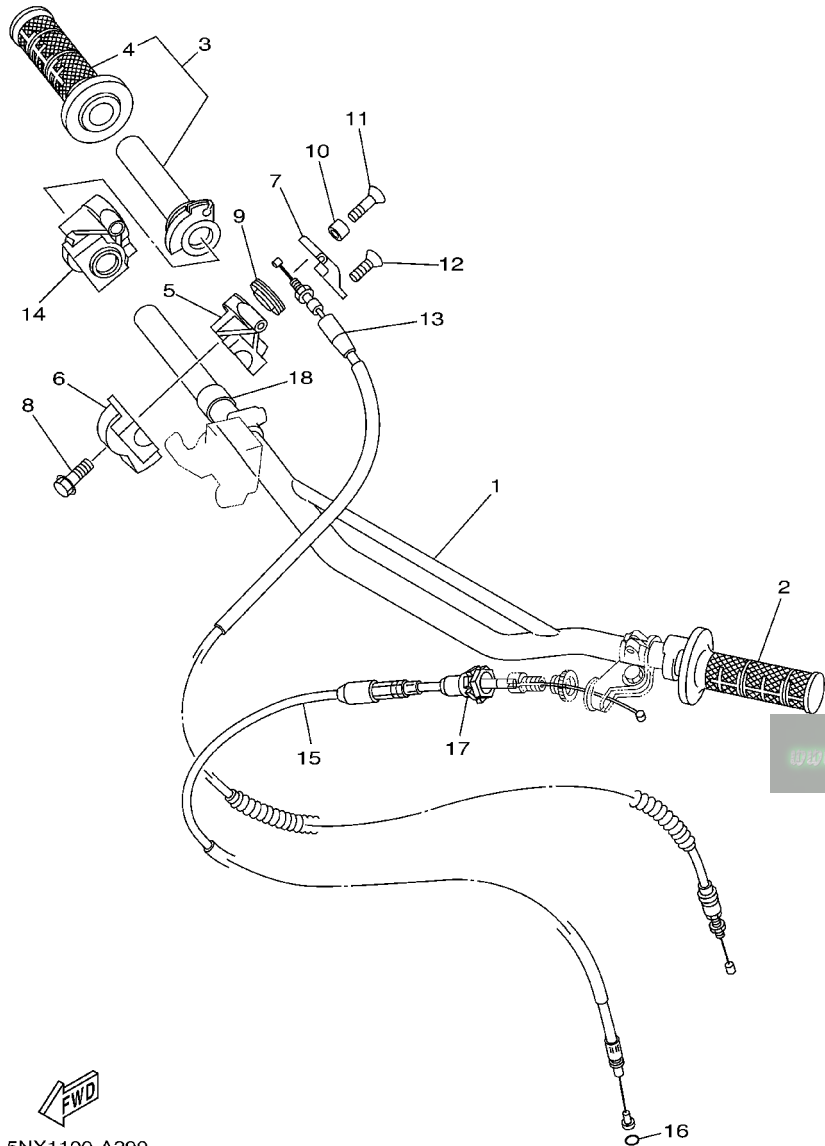

REF. NO.	PART NO.	DESCRIPTION	5UP1	5UP2	5UP3	5UP4	REMARKS
1	5UN-26111-00	HANDLEBAR	1			1	
2	4GY-26241-00	GRIP	1	1	1	1	
3	4XM-26240-00	GRIP ASSY	1	1	1	1	
4	4GY-26242-00	.GRIP (RIGHT)	1	1	1	1	
5	4SS-26281-00	CAP, GRIP UPPER	1	1	1	1	
6	4SS-26282-10	CAP, GRIP LOWER	1	1	1	1	
7	4SS-2628H-00	CAP, WIRE	1	1	1	1	
8	95027-06025	BOLT, FLANGE	2	2	2	2	
9	5NY-26273-00	ROTOR	1	1	1	1	
10	4SS-26259-00	COLLAR	1	1	1	1	
11	4SS-26256-00	SCREW, GRIP END	1	1	1	1	
12	4SS-2632G-00	SCREW	1	1	1	1	
13	5HC-26311-00	CABLE, THROTTLE 1	1	1	1	1	
14	4SS-26287-01	COVER, CAP GRIP	1	1	1	1	
15	5HC-26335-10	CABLE, CLUTCH	1	1	1	1	
16	93210-06001	O-RING	1	1	1	1	
17	5HD-26342-00	BOOT, CABLE	1	1	1	1	
18	90387-227H7	COLLAR	1	1	1	1	

5NX1100-A290

FIG. 30 FRONT MASTER CYLINDER

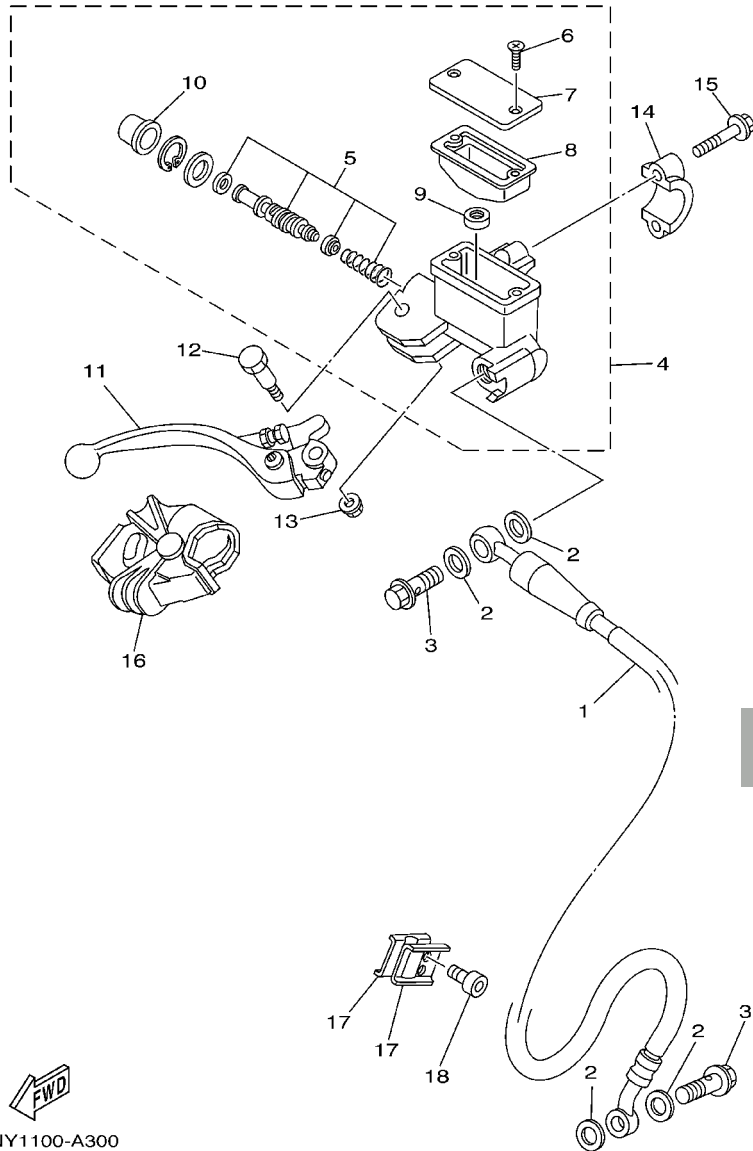

REF. NO.	PART NO.	DESCRIPTION	5UP1	5UP2	5UP3	5UP4	REMARKS
1	5ET-25872-00	HOSE, BRAKE 1	1				
2	90201-10118	WASHER, PLATE	4	4	4	4	
3	90401-10172	BOLT, UNION	2	2	2	2	
4	5UN-W2587-00	MASTER CYLINDER SUB ASSY	1	1	1	1	
5	5NY-W0041-00	.CYLINDER KIT, MASTER	1	1	1	1	
6	98706-04012	.SCREW, FLAT HEAD	2	2	2	2	
7	5MV-25852-01	.CAP, RESERVOIR	1	1	1	1	
8	56A-25854-00	.DIAPHRAGM, RESERVOIR	1	1	1	1	
9	5CG-25715-00	.SEPARATOR ASSY	1	1	1	1	
10	5NY-25868-00	.BOOT, MASTER CYLINDER	1	1	1	1	
11	5MV-83922-00	LEVER 2	1	1	1	1	
12	5MV-2589F-00	BOLT, LEVER	1	1	1	1	
13	95701-06500	NUT, FLANGE	1	1	1	1	
14	5MV-25867-00	BRACKET, MASTER CYLINDER	1	1	1	1	
15	5MV-25833-00	BOLT, FITTING	2	2	2	2	
16	5NY-26372-00	COVER, HANDLE LEVER 1	1	1	1	1	
17	90465-16258	CLAMP	2	2	2	2	
18	91317-06014	BOLT	2	2	2	2	

www.legends-yamaha-enduros.com

5NY1100-A300

FIG. 31 STAND, FOOTREST

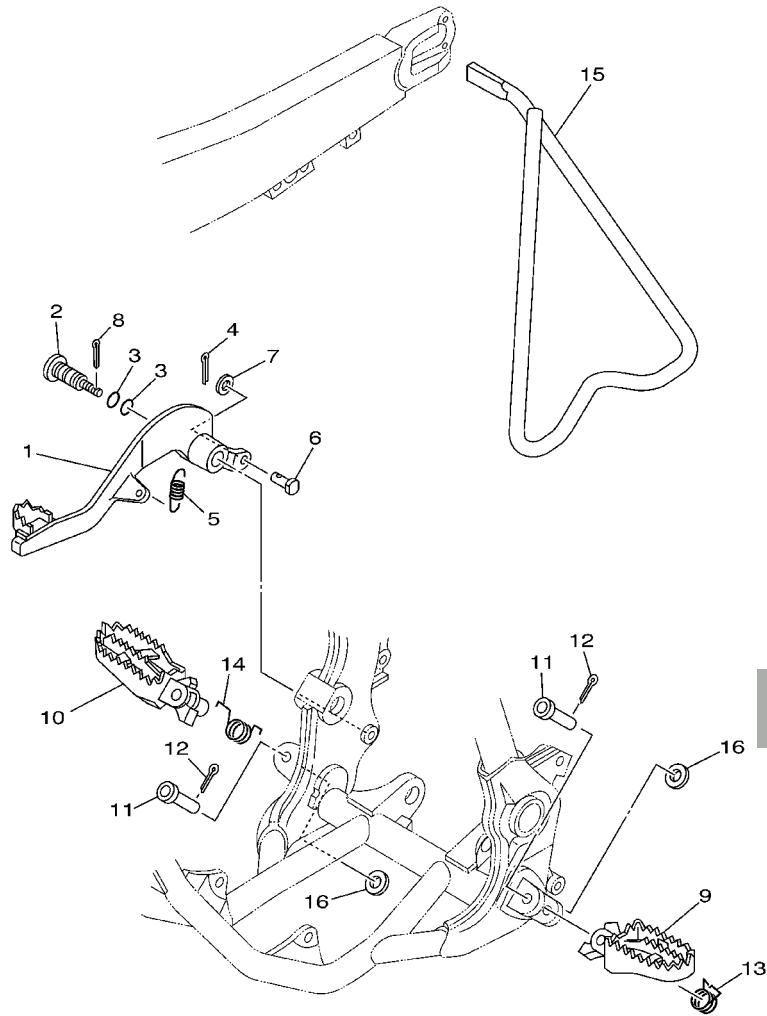

REF. NO.	PART NO.	DESCRIPTION	5UP1	5UP2	5UP3	5UP4	REMARKS
1	4XM-27200-00	PEDAL, BRAKE	1	1	1	1	
2	5JG-27217-00	BOLT	1	1	1	1	
3	93210-11073	O-RING	2	2	2	2	
4	91401-20012	PIN, COTTER	1	1	1	1	
5	90506-16500	SPRING, TENSION	1	1	1	1	
6	90240-08120	PIN, CLEVIS	1	1	1	1	
7	90201-08089	WASHER, PLATE	1	1	1	1	
8	90468-16191	CLIP	1	1	1	1	
9	5ET-27411-00	FOOTREST 1	1	1	1	1	
10	5ET-27421-00	FOOTREST 2	1	1	1	1	
11	90240-10142	PIN, CLEVIS	2	2	2	2	
12	91401-25015	PIN, COTTER	2	2	2	2	
13	90508-282B8	SPRING, TORSION	1	1	1	1	
14	90508-282B9	SPRING, TORSION	1	1	1	1	
15	5ET-27311-00	STAND, SIDE	1	1	1	1	
16	90201-10119	WASHER, PLATE	2	2	2	2	

www.legends-gamaha-enduros.com



5NY1100-A310

FIG. 32 REAR MASTER CYLINDER

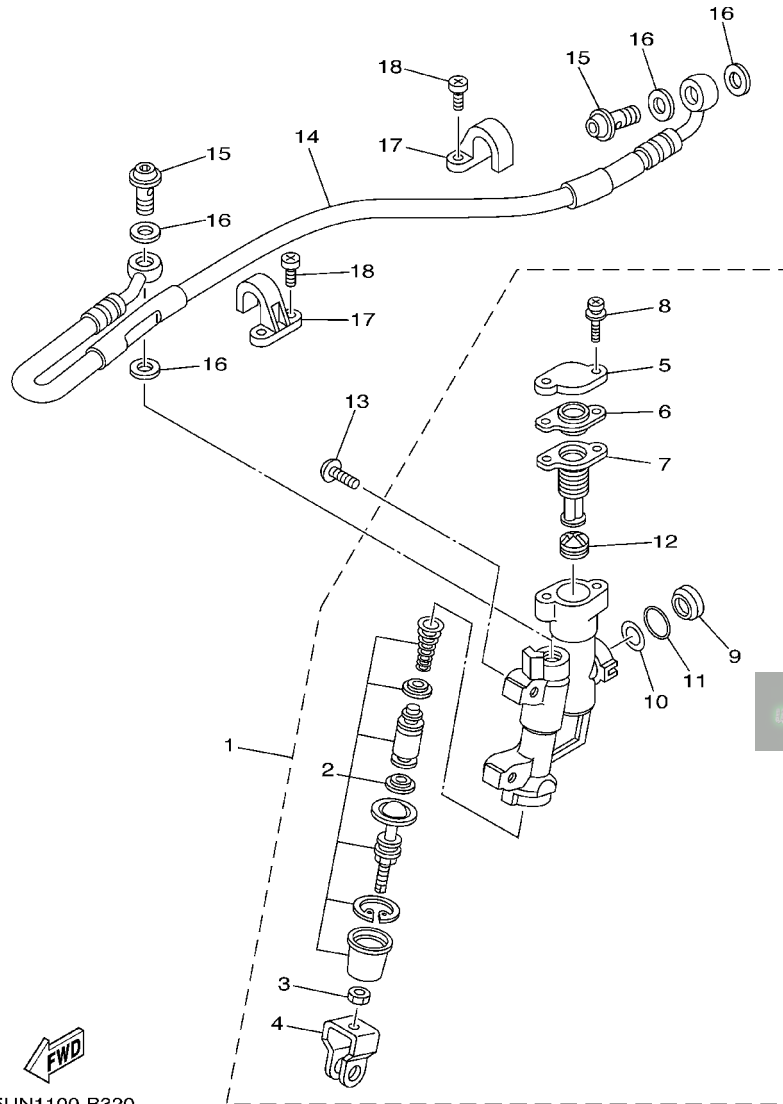

REF. NO.	PART NO.	DESCRIPTION	5UP1	5UP2	5UP3	5UP4	REMARKS
1	5UN-2583V-00	RR. MASTER CYLINDER ASSY.	1	1	1	1	
2	5UN-W0042-50	.CYLINDER KIT, MASTER	1	1	1	1	
3	5UN-27218-00	.NUT	1	1	1	1	
4	5UN-27222-00	.JOINT	1	1	1	1	
5	5UN-25852-50	.CAP, RESERVOIR	1	1	1	1	
6	5UN-2585B-00	.PLATE, DIAPHRAGM	1	1	1	1	
7	5UN-25854-00	.DIAPHRAGM, RESERVOIR	1	1	1	1	
8	5UN-27217-00	.BOLT	2	2	2	2	
9	4L0-25908-01	.GAUGE,COMP LEVEL	1	1	1	1	
10	59X-25957-00	.PLATE,REFRECTION	1	1	1	1	
11	4L0-25864-01	.CIRCLIP	1	1	1	1	
12	5CG-25715-00	.SEPARATOR ASSY	2	2	2	2	
13	90111-06029	BOLT	2	2	2	2	
14	5UN-25873-00	HOSE, BRAKE 2	1	1	1	1	
15	90401-10172	BOLT, UNION	2	2	2	2	
16	90201-10118	WASHER, PLATE	4	4	4	4	
17	2VM-25876-00	HOLDER, BRAKE HOSE 2	2	2	2	2	
18	98507-05010	SCREW, PAN HEAD	4	4	4	4	

5UN1100-B320

FIG. 33 GENERATOR

REF. NO.	PART NO.	DESCRIPTION	5UP1	5UP2	5UP3	5UP4	REMARKS
1	5CU-85560-02	BASE ASSY	1	1	1	1	
2	5UP-85550-00	ROTOR ASSY	1	1	1	1	
3	90149-06011	SCREW	3	3	3	3	
4	90179-12248	NUT	1	1	1	1	
5	90201-12688	WASHER, PLATE	1	1	1	1	

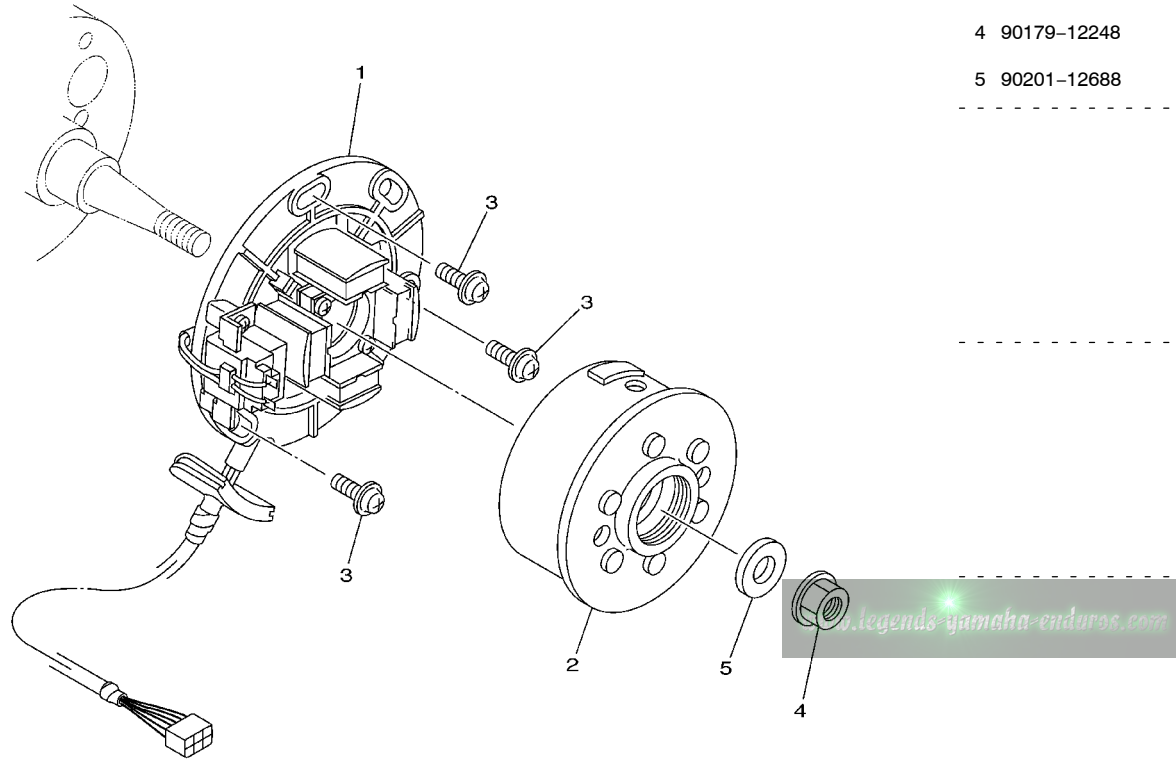

5NX1100-A330

FIG. 34 HANDLE SWITCH. LEVER

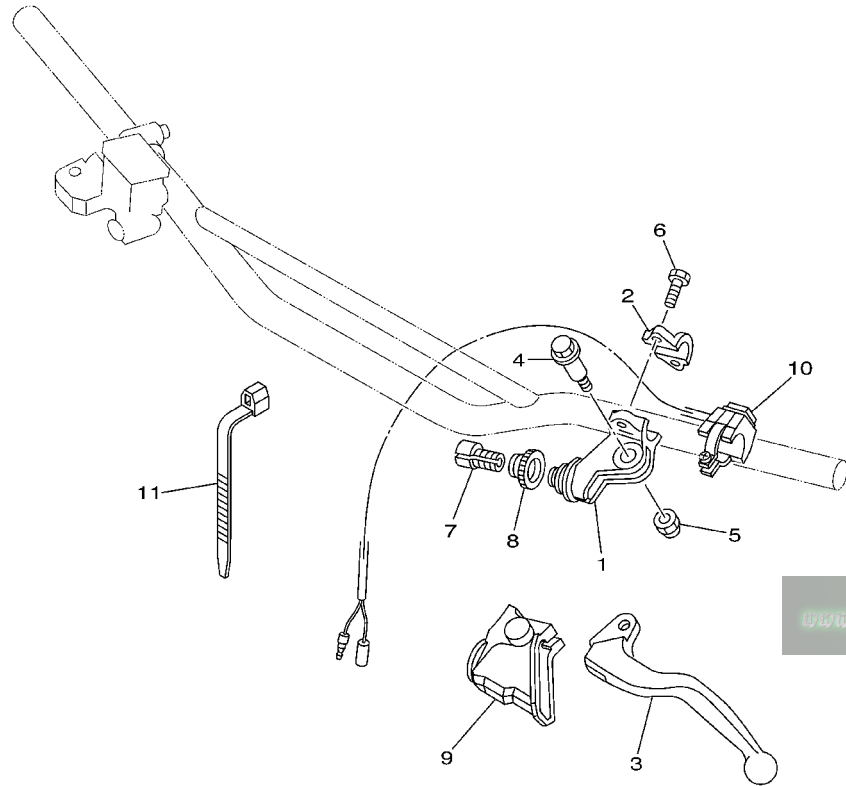

REF. NO.	PART NO.	DESCRIPTION	5UP1	5UP2	5UP3	5UP4	REMARKS
1	5HD-82911-00	HOLDER, LEVER 1	1	1	1	1	
2	38V-82913-00	HOLDER, LEVER LOWER 1	1	1	1	1	
3	5MV-83912-00	LEVER 1	1	1	1	1	
4	90109-06027	BOLT	1	1	1	1	
5	95607-06100	NUT, U	1	1	1	1	
6	97007-05016	BOLT	2	2	2	2	
7	5HD-26337-00	BOLT, ADJUSTING	1	1	1	1	
8	5HD-83951-00	BOLT, CABLE ADJUSTING	1	1	1	1	
9	5HD-26372-00	COVER, HANDLE LEVER 1	1	1	1	1	
10	23X-83976-00	SWITCH, HANDLE 1	1	1	1	1	
11	90464-13077	CLAMP	3	3	3	3	



5NY1100-A340

FIG. 35 ELECTRICAL 1

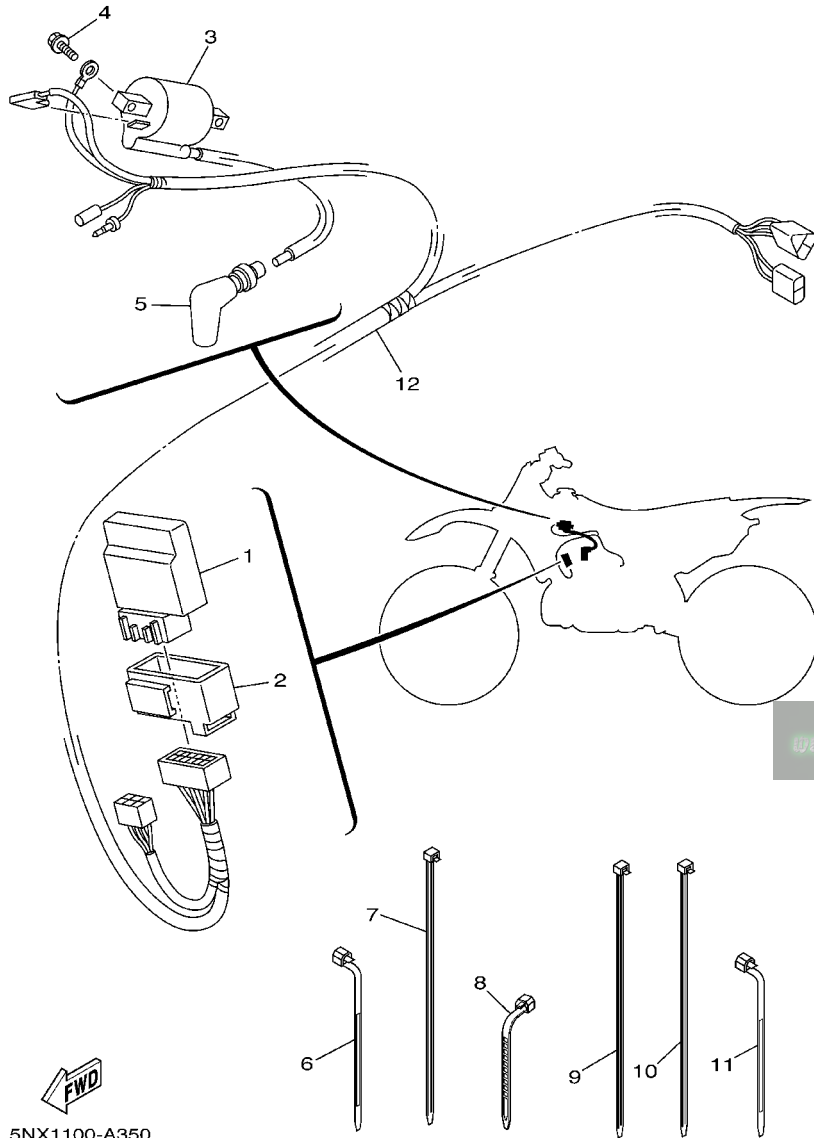

REF. NO.	PART NO.	DESCRIPTION	SUP1	SUP2	SUP3	SUP4	REMARKS
1	5NX-85540-00	C.D.I. UNIT ASSY	1	1	1	1	
2	5NY-85546-00	BAND	1	1	1	1	
3	4MX-82310-00	IGNITION COIL ASSY	1	1	1	1	
4	95027-06016	BOLT, FLANGE	2	2	2	2	
5	8DG-82370-00	PLUG CAP ASSY	1	1	1	1	
6	90464-15195	CLAMP	1	1	1	1	
7	90464-50255	CLAMP	2	2	2	2	
8	90464-13073	CLAMP	1	1	1	1	
9	90464-50255	CLAMP	1	1	1	1	
10	90464-50255	CLAMP	1	1	1	1	
11	90464-15195	CLAMP	1	1	1	1	
12	5NX-82509-01	WIRE, SUB LEAD	1	1	1	1	

FWD
5NX1100-A350

FIG. 36 ALTERNATE (CHASSIS)

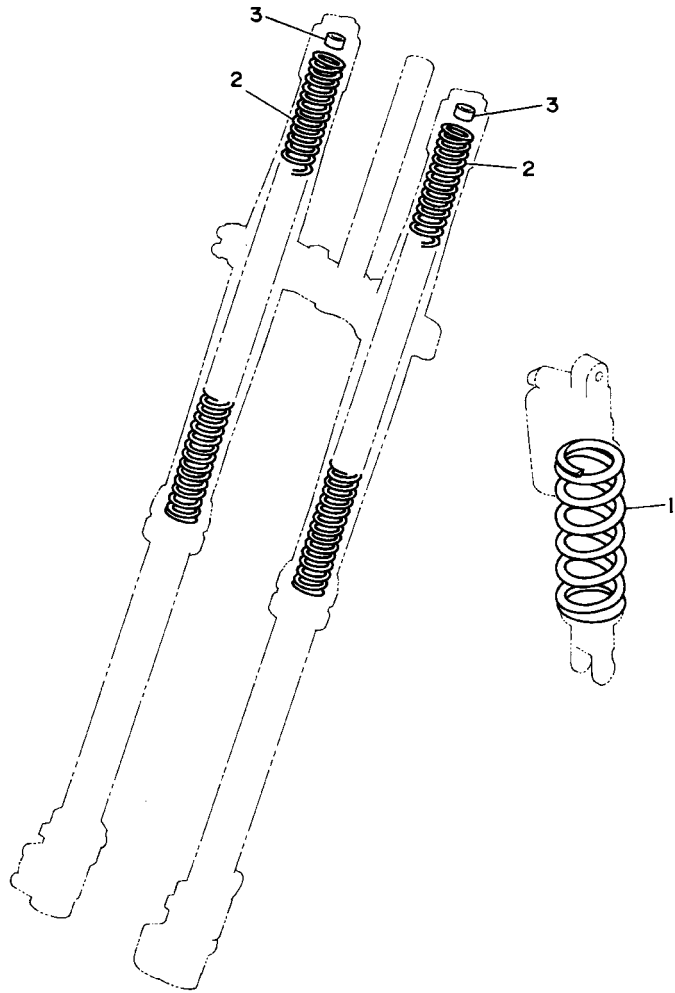

REF. NO.	PART NO.	DESCRIPTION	5UP1	5UP2	5UP3	5UP4	REMARKS
1	5UN-22212-00	SPRING (K=4.3)	1	1	1	1	AP
	5UN-22212-10	SPRING (K=4.5)	1	1	1	1	AP
	5UN-22212-20	SPRING (K=4.7)	1	1	1	1	AP
	5UN-22212-30	SPRING (K=4.9)	1	1	1	1	AP
	5UN-22212-40	SPRING (K=5.1)	1	1	1	1	AP
	5UN-22212-50	SPRING (K=5.3)	1	1	1	1	AP
	5UN-22212-60	SPRING (K=5.5)	1	1	1	1	AP
	5UN-22212-70	SPRING (K=5.7)	1	1	1	1	AP
	5UN-22212-A0	SPRING (K=APPROX.4.5)	1	1	1	1	AP
	5UN-22212-B0	SPRING (K=APPROX.4.7)	1	1	1	1	AP
	5UN-22212-C0	SPRING (K=APPROX.4.9)	1	1	1	1	AP
	5UN-22212-D0	SPRING (K=APPROX.5.1)	1	1	1	1	AP
	5UN-22212-E0	SPRING (K=APPROX.5.3)	1	1	1	1	AP
	5UN-22212-F0	SPRING (K=APPROX.5.5)	1	1	1	1	AP
	5UN-22212-G0	SPRING (K=APPROX.5.7)	1	1	1	1	AP
2	4SS-23141-10	SPRING, FRONT FORK (K=0.38)	2	2	2	2	AP
	4SS-23141-20	SPRING, FRONT FORK (K=0.39)	2	2	2	2	AP
	4SS-23141-30	SPRING, FRONT FORK (K=0.40)	2	2	2	2	AP
	4SS-23141-40	SPRING, FRONT FORK (K=0.41)	2	2	2	2	AP
	4SS-23141-50	SPRING, FRONT FORK (K=0.42)	2	2	2	2	AP
	4SS-23141-70	SPRING, FRONT FORK (K=0.44)	2	2	2	2	AP
	5ET-23141-20	SPRING (K=APPROX.0.40)	2	2	2	2	AP
	5ET-23141-00	SPRING (K=APPROX.0.41)	2	2	2	2	AP
	5ET-23141-30	SPRING (K=APPROX.0.42)	2	2	2	2	AP
	5ET-23141-10	SPRING (K=APPROX.0.43)	2	2	2	2	AP
	5ET-23141-40	SPRING (K=APPROX.0.44)	2	2	2	2	AP



3XJ1100-1360

FIG. 36 ALTERNATE (CHASSIS)

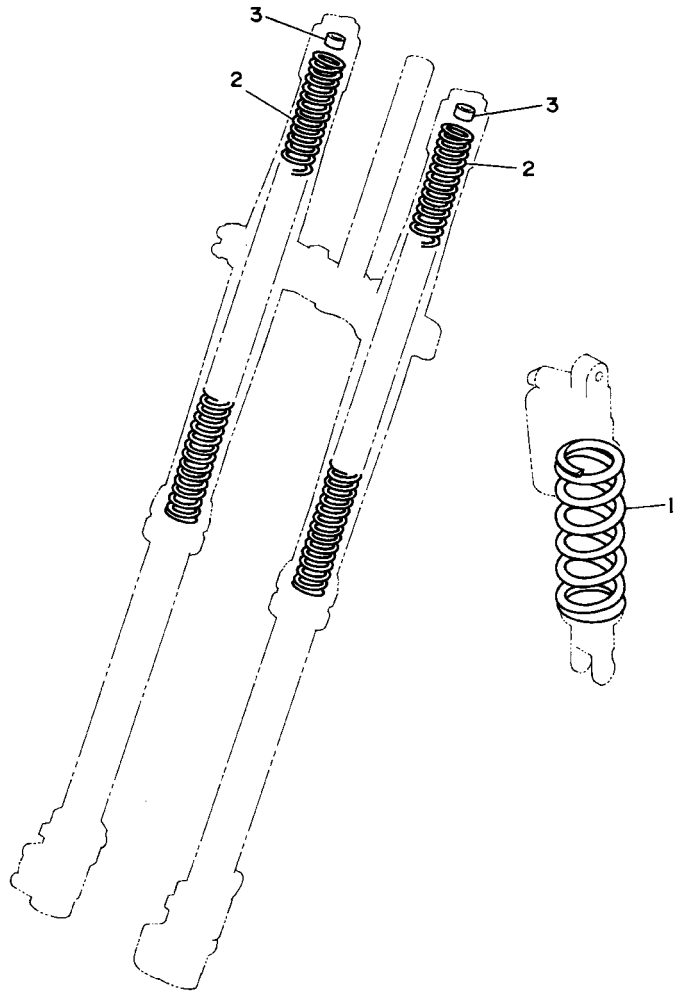



3XJ1100-1360

www.legends-gamaha-enduros.com

REF. NO.	PART NO.	DESCRIPTION	SUP1	SUP2	SUP3	SUP4	REMARKS
3	4SS-23364-L0	COLLAR 2	2	2	2	2	UN

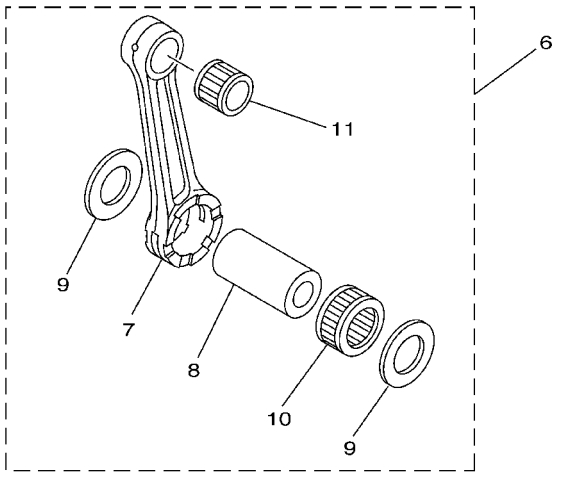
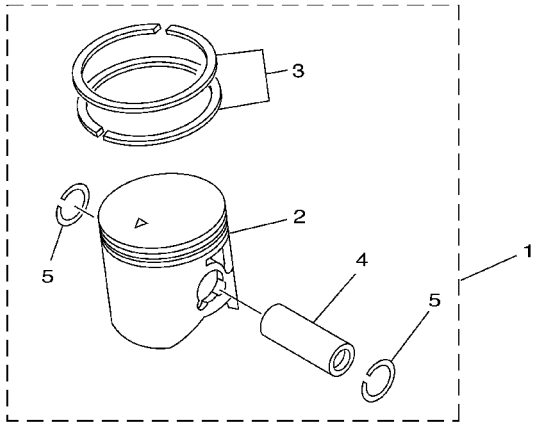
FIG. 37 OPTIONAL PARTS 1



REF. NO.	PART NO.	DESCRIPTION	5UP1	5UP2	5UP3	5UP4	REMARKS
1	5UP-11630-00	PISTON ASSY (STD)	1	1	1	1	
2	5UP-11631-00-B0	.PISTON (STD)	1	1	1	1	
3	5CU-11603-10	.PISTON RING SET (STD)	1	1	1	1	
4	5CU-11633-10	.PIN, PISTON	1	1	1	1	
5	93450-19052	.CIRCLIP	2	2	2	2	
6	5MW-11650-00	CONNECTING ROD ASSY	1	1	1	1	
7	5MW-11651-00	.ROD, CONNECTING	1	1	1	1	
8	5CU-11681-00	.PIN, CRANK 1	1	1	1	1	
9	90209-24327	.WASHER	2	2	2	2	
10	93310-52406	.BEARING	1	1	1	1	
11	93310-218A6	.BEARING	1	1	1	1	

www.legends-gamaha-enduros.com



5MW1100-1370

NUMERICAL INDEX

PART NO.	GRID NO.	PART NO.	GRID NO.	PART NO.	GRID NO.	PART NO.	GRID NO.	PART NO.	GRID NO.	PART NO.	GRID NO.
5NY-W0041-00	E - 2	4JY-11915-01	B - 4	5HC-14216-00	B - 11	4JT-1494F-13	B - 11	5DJ-16111-00	C - 3	5HD-21511-00	C - 11
5UN-W0042-50	E - 4	5X4-11921-02	B - 4	5NX-14216-00	B - 12	4MX-14943-40	B - 10	5MW-16113-00	C - 3	4XL-2153A-10	D - 6
5MV-W0045-01	D - 11	3JE-11922-01	B - 4	5HC-14261-00	B - 10	4MX-14943-41	B - 10	5DJ-16150-00	C - 3	5UN-2153A-00	C - 14
5UN-W0046-00	D - 14	5CU-11952-00	B - 4	5HC-14264-00	B - 11	4MX-14943-42	B - 10	2K7-16154-00	C - 3	4ES-2153E-01	C - 11
3JD-W0047-00	D - 11	5NY-11953-00	B - 4	5HC-14275-00	B - 11	4MX-14943-43	B - 11	5CU-16154-00	C - 3	5UN-21610-00	C - 11
5UN-W0047-50	D - 14	5CU-11956-00	C - 3	5HC-14340-A7	B - 10	4MX-14943-44	B - 11	2VM-16181-00	C - 3	5NX-2163G-00	C - 11
1UY-W0048-50	D - 11	5CU-11990-00	B - 4	4MX-14392-00	B - 9	4MX-14943-45	B - 11	3XK-16321-00	C - 3	5UN-21635-00	C - 11
	D - 14	5CU-11991-00	B - 3	5NY-14401-01	B - 8	4MX-14943-90	B - 10	4X7-16325-00	C - 3	5UN-21642-00	C - 11
5UN-W0057-00	D - 11	5CU-11993-00	B - 3	5NY-14417-00	B - 8	4MX-14943-91	B - 10	5JG-16351-00	C - 3	5NY-21711-00	C - 12
5UN-W0057-50	D - 14	5CU-11995-00	B - 3	5NY-14442-00	B - 8	4MX-14943-92	B - 10	4XL-16356-00	C - 3	5GJ-21717-00	C - 9
5UN-W2587-00	E - 2	5NX-1240A-00	B - 7	4XM-14451-00	B - 8	4MX-14943-93	B - 10	5CU-16357-10	C - 3	5NL-2172A-10	C - 12
5MW-11111-01	B - 2	5MW-12422-00	B - 6	4MX-14453-00	B - 8	4MX-14943-94	B - 11	5NX-16371-00	C - 3	5NY-21721-00	C - 12
5UP-11111-00	B - 2	5CU-12428-00	B - 6	5NY-14455-10	B - 8	4MX-14943-95	B - 11	5CU-16380-10	C - 3	5UN-2173E-00	C - 12
5NX-1131D-01	B - 2	5DJ-12451-00	B - 6	3JD-14458-01	B - 8	4MX-14948-02	B - 9	5JG-17121-10	C - 5	5UN-2173F-00	C - 12
5CU-1131E-00	B - 2	5CU-12459-00	B - 6	5NY-14459-00	B - 8	4MX-14948-03	B - 9	5CU-17131-00	C - 5	5NY-21730-00	C - 12
5CU-1131M-00	B - 3	5NX-12461-00	B - 7	676-14548-00	B - 10	4MX-14948-04	B - 9	5BE-17141-30	C - 5	5NY-21740-00	C - 12
5CU-1131P-00	B - 2	5HD-12462-00	B - 7	4MX-14561-00	B - 9	4MX-14948-05	B - 9	5BE-17151-00	C - 5	3JD-21748-00	C - 11
5CU-1131U-10	B - 2	5CU-12481-10	B - 7	5NY-14562-00	B - 11	4MX-14948-06	B - 9	5BE-17211-00	C - 5	5MV-2175C-00	C - 12
5CU-1131V-00	B - 3	5NY-12482-00	B - 7	5MW-14610-10	B - 13	4MX-14948-07	B - 9	5JG-17221-10	C - 5	5UN-22110-00	C - 13
5UP-11311-00	B - 2	5CU-12484-10	B - 7	5UP-14610-00	B - 13	4MX-14948-08	B - 9	5BE-17231-00	C - 5	5NY-22121-00	C - 13
5CU-1132A-00	B - 2	353-13115-01	B - 3	3JE-14615-01	B - 13	4MX-14948-09	B - 9	5JG-17241-00	C - 5	5NY-22122-00	C - 14
5MW-1132E-00	B - 3		B - 14	5MW-14642-00	B - 13	4MX-14948-10	B - 9	5BE-17251-10	C - 5	5UN-22128-00	C - 13
5MW-1132F-00	B - 3	5NX-13565-00	B - 8	5CU-1469A-00	B - 13	4MX-14948-11	B - 9	5BE-17411-00	C - 5	5NY-22141-01	C - 13
5UP-11351-00	B - 2	5NX-13610-00	B - 8	5HC-1469A-10	B - 13	4MX-14948-12	B - 9	5BE-17421-00	C - 5	5UN-22151-00	C - 13
5CU-11354-00	B - 3	5NX-13613-00	B - 8	5NX-14753-00	B - 13	4JT-14984-00	B - 9	5HC-17466-00	B - 15	5JG-22156-00	C - 13
5NX-11395-00	B - 3	4XL-13616-00	B - 8	5NX-14753-10	B - 13	4SR-14985-00	B - 9	4L0-17471-00	B - 14	5NY-2217A-00	C - 13
5UP-11400-00	B - 5	5NX-13622-00	B - 8	5CU-14771-00	B - 13	5NX-15111-00	B - 14	5CU-18101-10	C - 8	5NY-2217F-00	C - 14
5UP-11410-00	B - 5	5NX-13624-00	B - 8	483-14781-02	B - 13	4V4-15118-00	B - 14	5CU-18110-00	C - 8	5UN-22176-00	C - 15
5MW-11420-00	B - 5	4XL-13625-00	B - 8	4SR-14916-CJ	B - 9	5CU-15118-00	B - 14	5MW-18122-00	C - 8	3JD-22178-10	C - 9
5CU-11603-10	B - 5	4XL-1410E-00	B - 11		B - 10	5NX-15121-00	B - 14	4BR-18127-10	C - 7	4EW-22178-00	C - 9
	E - 10	5NX-1410H-00	B - 11	4SR-14916-CK	B - 10	3Y1-15363-00	B - 15	5CU-18140-01	C - 7	5MV-22184-00	C - 15
5UP-11630-00	E - 10	5NX-14101-00	B - 9	4SR-14916-CW	B - 10	4JT-15381-01	B - 14	5CU-18172-00	C - 8	5UN-22199-00	C - 13
5NX-11631-00-A0	B - 5	5NX-14101-20	B - 9	4SR-14916-EH	B - 10	5CU-15411-00	B - 15	3XJ-18173-00	C - 8	5UP-22201-00	C - 15
5NX-11631-00-B0	B - 5	5UP-14101-10	B - 9	4SR-14916-EJ	B - 9	5MW-15415-00	B - 15	3XJ-18178-00	C - 8	5UP-22201-10	C - 15
5NX-11631-00-C0	B - 5	4SR-14105-00	B - 10		B - 10	5CU-15421-00	B - 15	3XJ-18182-00	C - 8	5UP-22201-20	C - 15
5NX-11631-00-D0	B - 5	4MX-14115-00	B - 9	4SR-14916-EK	B - 10	5NX-15431-00	B - 15	3XJ-18184-00	C - 8	5UP-22201-30	C - 15
5UP-11631-00-B0	E - 10	5HC-14126-00	B - 10	4SR-14916-EW	B - 9	5CU-15451-00	B - 15	4EW-18185-00	C - 7	5UP-22201-40	C - 15
5CU-11633-10	E - 10	5HC-14131-00	B - 10	4SR-14916-RH	B - 10	5CU-15454-00	B - 14	5BE-18501-20	C - 7	5UP-22210-00	C - 15
5UP-11633-00	B - 5	3TJ-14137-40	B - 10	4SR-14916-RJ	B - 9	5CU-15462-00	B - 15	5BE-18502-20	C - 7	5UP-22210-10	C - 15
5MW-11650-00	E - 10	4XL-14146-00	B - 9	4SR-14916-RW	B - 9	5CU-15463-00	B - 15	5CU-18503-20	C - 7	5UP-22210-20	C - 15
5MW-11651-00	B - 5	5HC-14146-00	B - 11		B - 10	5NX-15601-00	C - 2	5MW-18541-00	C - 7	5UP-22210-30	C - 15
	E - 10	4JT-14147-00	B - 11	4MX-14919-00	B - 10	5NX-15620-00	C - 2	5DH-18562-00	C - 7	5UP-22210-40	C - 15
5CU-11681-00	B - 5	663-14159-00	B - 10	5HC-14922-00	B - 11	5NX-15621-01	C - 2	5UP-21101-00	C - 9	5UN-22212-A0	E - 8
	E - 10	4JT-14171-00	B - 9	5HC-14934-00	B - 11	5CU-15651-00	C - 2	5UN-21190-00	C - 9	5UN-22212-B0	E - 8
5CU-11830-00	B - 3	4MX-14194-00	B - 11	4JT-1494F-03	B - 11	5NL-15664-00	C - 2	5HD-2135F-00	C - 14	5UN-22212-C0	C - 15
4SS-11832-00	B - 3	4XL-14196-10	B - 10	4JT-1494F-07	B - 11	4GY-15671-00	C - 2	5NY-2135F-00	C - 14		E - 8
5CU-11911-00	B - 4	4XL-14197-10	B - 10	4JT-1494F-09	B - 11	214-15674-00	C - 2	5NX-21425-00	C - 9	5UN-22212-D0	E - 8
5CU-11912-00	B - 4	5NX-14208-00	B - 11	4JT-1494F-11	B - 11	214-15686-00	C - 2	4GG-21488-00	C - 9	5UN-22212-E0	E - 8

NUMERICAL INDEX

PART NO.	GRID NO.	PART NO.	GRID NO.	PART NO.	GRID NO.	PART NO.	GRID NO.	PART NO.	GRID NO.	PART NO.	GRID NO.
5UN-22212-F0	E-8	4SR-23141-L0	D-5	5NY-23346-L0	D-5	5NY-25449-00	D-12	4SS-26281-00	D-15	90109-06027	E-6
5UN-22212-G0	E-8	4SS-23141-10	E-8	3SP-23356-L0	D-6	5NY-25450-00	D-12	4SS-26282-10	D-15	90109-063F8	C-7
5UN-22212-00	E-8	4SS-23141-20	E-8	4SS-23364-L0	E-9	5NY-25451-00	D-12	4SS-26287-01	D-15	90109-065G4	D-14
5UN-22212-10	E-8	4SS-23141-30	E-8	4DA-23389-00	D-6	5NY-25452-00	D-12	5HC-26311-00	D-15	90109-067F4	B-8
5UN-22212-20	E-8	4SS-23141-40	E-8	5HD-2339E-00	D-3	5CG-25715-00	E-2	4SS-2632G-00	D-15	90109-081G1	D-12
5UN-22212-30	C-15	4SS-23141-50	E-8	5HD-23393-L0	D-4		E-4	5HC-26335-10	D-15	90109-085E2	C-2
	E-8	4SS-23141-60	E-8		D-5	5DH-25718-01	D-14	5HD-26337-00	E-6	90110-08096	C-9
5UN-22212-40	E-8	4SS-23141-70	E-8	4EW-23416-00	D-3	5UN-2580T-00	D-11	5HD-26342-00	D-15	90111-06029	E-4
5UN-22212-50	E-8	4XL-23141-L0	D-4	5HC-23435-00	D-3	5UN-2580W-00	D-14	5HD-26372-00	E-6	90116-08394	B-2
5UN-22212-60	E-8		D-5	5NL-23435-00	D-3	5MV-2581T-00	D-11	5NY-26372-00	E-2	90116-10314	B-2
5UN-22212-70	E-8	5CU-23141-L0	D-4	3SP-23441-00	D-3	5NY-2582W-00	D-14	4XM-27200-00	E-3	90119-05071	D-6
3SP-22213-00	C-15		D-5	5HD-23485-00	D-3	5UN-25827-50	D-14	5JG-27217-00	E-3	90119-06038	B-7
5DH-22214-00	C-15	5ET-23141-00	E-8	5NY-24110-00	D-7	5UN-25828-50	D-14	5UN-27217-00	E-4	90119-06096	C-11
5MV-22224-00	C-15	5ET-23141-10	E-8	4EW-2412F-00	D-7	5UN-2583V-00	E-4	5UN-27218-00	E-4	90119-06192	B-13
4JX-22226-00	C-15	5ET-23141-20	E-8	24X-24144-00	D-7	5MV-25833-00	E-2	5UN-27222-00	E-4		C-11
3SP-22234-00	C-15	5ET-23141-30	E-8	3SP-24173-00	D-7	5UN-2585B-00	E-4	5ET-27311-00	E-3	90119-06214	D-7
5NY-22241-00	D-2	5ET-23141-40	E-8	4SS-24181-00	D-7	5MV-25852-01	E-2	5ET-27411-00	E-3	90119-06225	C-11
5DH-22253-00	C-15	5DH-23142-L0	D-4	5UN-24182-00	D-7	5UN-25852-50	E-4	5ET-27421-00	E-3	90119-08238	C-12
5MV-22253-00	C-15		D-5	5NY-24183-10	D-7	5UN-25854-00	E-4	5UN-27491-00	D-14	90122-06035	B-8
5UN-22355-00	C-13	5HD-23144-L0	D-4	5NY-24186-00	D-7	56A-25854-00	E-2	5ET-28166-00	C-10	90149-06011	D-7
4EW-22474-00	C-15		D-5	5UN-24240-00	D-7	4LO-25864-01	E-4	4MX-82310-00	E-7		E-5
3JE-22475-00	C-15	5ET-23145-L0	D-4	3XJ-24380-00	D-7	5MV-25867-00	E-2	8DG-82370-00	E-7	90149-06326	B-14
5NY-22475-00	C-15		D-5	3JD-24500-01	D-7	5NY-25868-00	E-2	5NX-82509-01	E-7	90149-06327	D-11
5UN-22898-50	D-14	5UN-23146-L0	D-4	4X8-24512-00	D-7	5ET-25872-00	E-2	5HD-82911-00	E-6	90151-04048	C-13
5UP-23102-00	D-4		D-5	3AJ-24534-00	D-7	5HD-25872-00	E-2	38V-82913-00	E-6	90152-06010	C-2
5UP-23102-10	D-4	5DH-23149-L0	D-4	5UN-24610-00	D-7	5UN-25873-00	E-4	5MV-83912-00	E-6	90157-06077	B-14
5UP-23102-20	D-4		D-5	5NY-2470F-00	D-9	5DH-25875-00	D-11	5MV-83922-00	E-2	90159-06010	C-3
5UP-23103-00	D-4	4SS-23153-L0	D-4	5NY-24728-00	D-9	2VM-25876-00	E-4	5HD-83951-00	E-6	90159-06078	C-12
5UP-23103-10	D-5		D-5	5NY-24770-00	D-9	5MV-2589F-00	E-2	23X-83976-00	E-6	90159-06182	C-12
5UP-23103-20	D-5	4SS-23158-L0	D-4	5NY-25104-00	D-10	4LO-25908-01	E-4	5NX-85540-00	E-7	90170-20255	C-3
5BF-23110-L0	D-5		D-5	5NY-25111-00	D-10	3SP-25914-51	D-11	5NY-85546-00	E-7	90170-24373	D-3
5UN-23111-L0	D-4	5UP-2316A-00	D-4	5NY-25117-00	D-10	5DH-25916-00	D-11	5UP-85550-00	E-5	90176-08026	B-2
	D-5		D-5	5BE-25181-00	D-10		D-14	5CU-85560-02	E-5	90179-06568	C-13
5DH-23118-L0	D-4	5UP-2316A-10	D-4	5NY-25183-00	D-10	5DH-25919-00	D-11	5NX-85885-00	B-11	90179-10M35	B-2
	D-5		D-5	5NY-25186-00	D-10	5DH-25919-50	D-14	9Y581-92113	D-13	90179-12248	E-5
3JD-2312G-L0	D-4	5UP-2316A-20	D-4	5HD-25304-00	D-12	8CR-25924-00	D-14	90101-06664	C-8	90179-16672	D-10
	D-5		D-5	5ET-25311-00	D-12	3SP-25926-51	D-11	90101-08777	D-13	90179-20255	C-6
5DH-23120-L0	D-4	5UN-23170-L0	D-4	5ET-25317-00	D-12	5DH-25933-00	D-11	90105-05002	B-4	90179-28650	D-3
5ET-23125-L0	D-4		D-5	4XM-25364-00	D-12	59X-25957-00	E-4	90105-06553	C-7	90183-06023	B-8
	D-5	5ET-23171-L0	D-4	5ET-25367-00	D-13	4XM-26111-00	D-15	90105-06556	B-14	90185-08055	C-9
5HD-23136-L0	D-4		D-5	5ET-25381-00	D-13	5UN-26111-00	D-15	90105-08120	C-9	90185-08169	C-9
	D-5	5DH-23183-00	C-15	5UN-25383-00	D-13	4XM-26240-00	D-15	90105-08494	C-9		D-13
5DH-2314E-00	D-11	509-23184-L0	C-15	5NY-25388-00	D-13	4GY-26241-00	D-15	90105-08659	D-11	90185-10002	C-9
5DH-2314F-L0	D-6	5MV-23195-L0	D-4	5NY-25389-00	D-13	4GY-26242-00	D-15	90105-10323	C-15	90185-10060	D-2
4SS-2314G-L0	D-6		D-5	3JE-25394-00	D-12	4SS-26256-00	D-15	90105-10445	C-3	90185-14007	C-14
5DH-2314H-00	D-6	5HC-2331E-00	D-6	5SF-25394-00	D-10	4SS-26259-00	D-15	90105-10731	C-9	90185-16127	C-13
5DH-2314J-00	D-6	5UP-23340-L0	D-5	5ET-25447-00	D-12	5NY-26273-00	D-15	90109-05001	B-2	90185-20168	D-13
4SR-23141-L0	D-4	4SS-23346-L0	D-6	5NY-25448-00	D-12	4SS-2628H-00	D-15	90109-056G0	C-3	90201-03313	B-8

NUMERICAL INDEX

PART NO.	GRID NO.	PART NO.	GRID NO.	PART NO.	GRID NO.	PART NO.	GRID NO.	PART NO.	GRID NO.	PART NO.	GRID NO.
90201-057H5	B- 2	90387-06009	C- 11	90501-046L6	B- 3	93109-28043	C- 13	93612-16254	B- 14	95607-10200	D- 2
	B- 4	90387-06039	B- 13	90501-052G5	C- 8	93210-06001	D- 15	9383E-13144	C- 6	95617-10660	B- 2
90201-06013	C- 7	90387-0614M	B- 7	90501-12081	C- 2	93210-11073	E- 3	9383E-14215	C- 6	95701-06500	E- 2
90201-06071	B- 13	90387-063G3	B- 13	90501-16016	C- 2	93210-15639	B- 2	94108-21011	D- 10	95707-08500	D- 13
	C- 11	90387-085E1	B- 4	90501-237L0	C- 3	93210-17570	C- 2	94108-2110Y	D- 10	95817-10050	C- 9
90201-06557	C- 11	90387-086N4	C- 9	90501-256L2	B- 4	93210-19123	B- 15	94108-2112Y	D- 10	95817-10110	C- 9
90201-080L8	B- 2	90387-124F4	C- 8	90506-16500	E- 3	93210-22298	C- 5	94111-1913A	D- 12	95827-06010	B- 7
90201-08089	E- 3	90387-152F2	B- 4	90507-14064	C- 7	93210-74316	B- 2	94111-1916B	D- 12	95827-06012	D- 11
90201-081G0	B- 3	90387-16005	C- 13	90507-20052	B- 13	93211-02703	B- 2	94111-1916C	D- 12	95827-06016	C- 12
90201-08326	C- 2	90387-16007	C- 13	90508-155B8	B- 3	93300-60801	B- 4	94209-21229	D- 10	97007-05016	E- 6
	D- 13	90387-167Y9	C- 13	90508-282B8	E- 3	93300-60804	C- 9	94211-19273	D- 12	97007-05020	B- 3
90201-08512	B- 6	90387-18004	C- 13	90508-282B9	E- 3	93306-00105	B- 6	94211-19274	D- 12	97027-06016	C- 2
90201-086P8	C- 9	90387-18005	C- 13	90508-291A8	C- 8	93306-00426	C- 5	94227-21101	D- 10	97307-06012	D- 9
90201-08730	B- 13	90387-18007	B- 14	90508-305B0	C- 2	93306-00442	C- 5	94309-21161	D- 10	97707-60016	C- 11
	C- 9	90387-2113G	C- 5	91A20-05065	B- 7	93306-07202	D- 12	94311-19155	D- 12	97801-03008	D- 7
90201-08784	B- 6	90387-227H7	D- 15	91317-04006	B- 4	93306-20540	C- 5	94321-19157	D- 12	98502-04012	B- 11
90201-10013	C- 9	90387-2515B	C- 5	91317-04008	B- 3	93306-20574	C- 5	94330-21084	D- 10	98502-04014	B- 10
90201-10118	E- 2	90401-10172	E- 2	91317-05008	C- 13	93306-27205	D- 12	94416-21003	D- 10	98507-03008	B- 8
	E- 4		E- 4	91317-06014	E- 2	93306-37808	B- 5	94421-19602	D- 12	98507-05010	E- 4
90201-10119	E- 3	90430-05242	C- 4	91317-06025	B- 8	93306-90403	D- 10	94681-68001	D- 13	98507-05012	B- 2
90201-105P3	C- 3	90430-06014	B- 6	91317-06050	B- 14	93306-90501	C- 7	94702-00326	B- 2	98507-06030	B- 15
90201-125L6	C- 3		B- 15	91317-06060	B- 14	93306-90504	C- 7	94709-00326	B- 2	98507-06035	B- 15
90201-12575	C- 8	90430-12227	B- 14	91317-06070	B- 14	93310-218A6	B- 5	95027-06010	B- 15	98580-04006	B- 11
90201-12688	E- 5	90445-08376	B- 14	91401-20012	E- 3		E- 10		C- 13	98706-04012	E- 2
90201-14740	C- 14	90445-09104	D- 7	91401-25015	E- 3	93310-230T7	C- 3	95027-06012	B- 13	98707-06025	D- 7
90201-150U6	B- 4	90445-09220	D- 7	92017-06010	B- 13	93310-52406	B- 5		D- 14	98907-05012	B- 3
90201-160F6	C- 13	90445-09777	B- 3	92907-03100	B- 8		E- 10	95027-06014	D- 3		B- 4
90201-162H4	C- 2	90445-111J0	D- 7	92907-05600	B- 3	93315-11206	C- 3	95027-06016	D- 7	98907-05016	B- 3
90201-167P7	C- 2	90450-25037	B- 7	92907-06100	D- 9	93315-32053	C- 14		D- 14	98907-06025	D- 7
90201-20276	C- 2	90450-28014	B- 7	92907-06600	B- 15	93315-32056	C- 13		E- 7	99001-06600	B- 6
90201-203U1	D- 13	90450-51070	B- 8	92907-08200	D- 11	93317-22262	C- 13	95027-06020	C- 8	99009-16400	C- 2
90201-20685	C- 2	90450-70072	B- 8	92907-10200	C- 9	93332-00068	D- 3	95027-06025	B- 6	99009-20400	C- 2
90201-247L2	D- 3	90464-06214	B- 8	93102-12106	B- 6	93332-00081	D- 3		B- 13	99009-45500	D- 12
90201-253K0	C- 5	90464-13073	E- 7	93102-12224	C- 3	93340-21505	B- 4		B- 15	99530-08016	B- 15
90201-286K9	D- 3	90464-13077	E- 6		C- 8		C- 3		D- 15	99590-14016	B- 2
90202-05193	D- 7	90464-15195	E- 7	93102-18278	C- 2	93342-22217	C- 13	95027-06030	B- 15		
90209-06096	B- 8	90464-50255	E- 7	93102-20485	B- 5	93410-20038	C- 2		C- 11		
90209-21332	C- 5	90465-13152	D- 8	93102-26468	D- 10	93440-10085	C- 3	95027-06050	B- 15		
90209-24327	B- 5	90465-13275	D- 7	93102-28004	B- 5	93440-25084	C- 5		C- 13		
	E- 10	90465-16258	E- 2	93102-32337	C- 5	93440-28062	C- 5	95027-06065	B- 6		
90209-26348	C- 5	90467-09006	B- 7	93104-08040	B- 3	93450-19052	B- 5		B- 15		
90215-20231	C- 3	90467-10008	D- 7		B- 4		E- 10	95027-08012	B- 13		
90215-21256	C- 6	90468-16191	E- 3	93106-22019	C- 13	93507-16020	B- 4	95027-08020	D- 11		
90240-08120	E- 3	90480-08608	D- 13	93106-30044	D- 12	93507-32009	C- 2	95027-08035	D- 3		
90240-10142	E- 3	90480-15528	B- 7	93106-30045	D- 12	93603-14240	B- 4	95027-08040	C- 9		
90267-32070	B- 8	90480-16404	B- 13	93109-11073	B- 6	93604-08071	B- 2		D- 3		
90280-03017	B- 5	90480-16561	B- 13	93109-20076	C- 13	93604-10011	B- 6	95027-08055	C- 9		
90340-12059	B- 14	90480-18549	D- 7		C- 14	93604-29184	B- 4	95607-06100	E- 6		