



YAMAHA

GENUINE

PARTS CATALOGUE

MOTORCYCLE

www.legends-yamaha-enduros.com

CYLINDER HEAD - CYLINDER

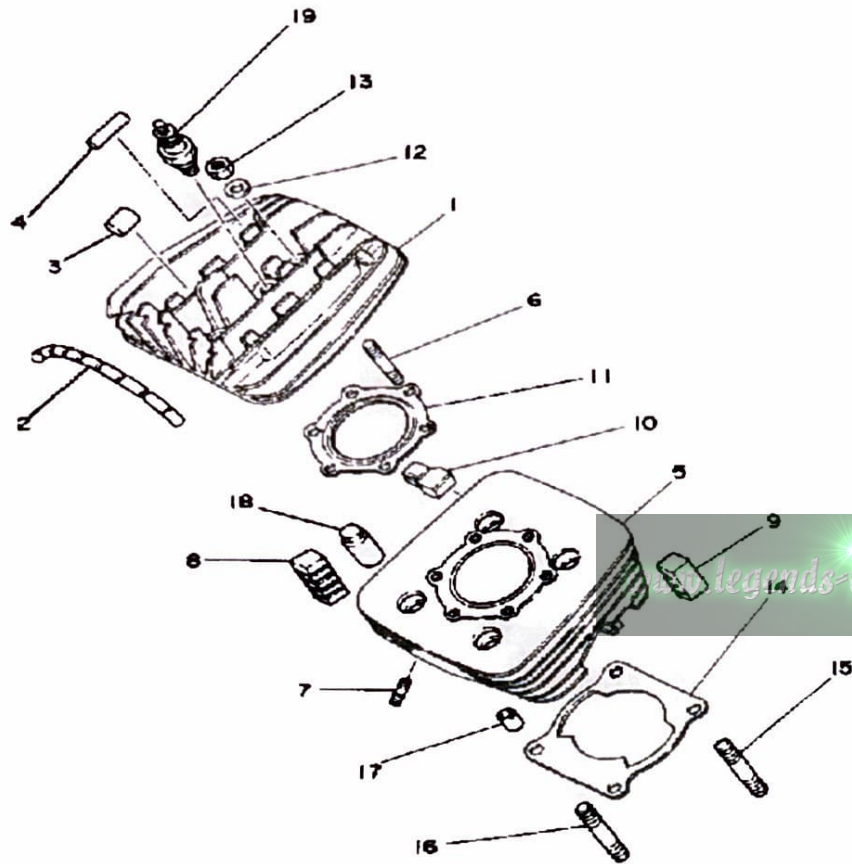

Ref. No.	Part Number	Description	Qty	Remarks
1	(3J1-11111-00-00)	HEAD, CYLINDER 1	1	
2	2A6-11161-00-00	ABSORBER 1	1	
3	2A6-11162-00-00	ABSORBER 2	1	
4	3LN-2139U-00-00	ABSORBER 2	2	
5	2A7-11311-00-00	CYLINDER 1	1	
6	90116-08104-00	BOLT, STUD	6	
7	90116-06016-00	BOLT, STUD	2	
8	2A6-11127-00-00	ABSORBER 3	2	
9	2A6-11127-00-00	ABSORBER 3	2	
10	2A6-11129-00-00	ABSORBER 5	1	
11	1W2-11181-00-00	GASKET, CYLINDER HEAD 1 .	1	
12	90201-08100-00	WASHER, PLATE	6	
13	95333-08600-00	NUT	6	
14	18G-11351-01-00	GASKET, CYLINDER	1	
15	95611-10630-00	BOLT, STUD	2	
16	95611-10640-00	BOLT, STUD	2	
17	99530-14016-00	PIN, DOWEL	2	
18	90179-10201-00	NUT	4	
19	NGK-B9ES0-00-00	NGK B9ES 10PK	1	

CRANKSHAFT - PISTON

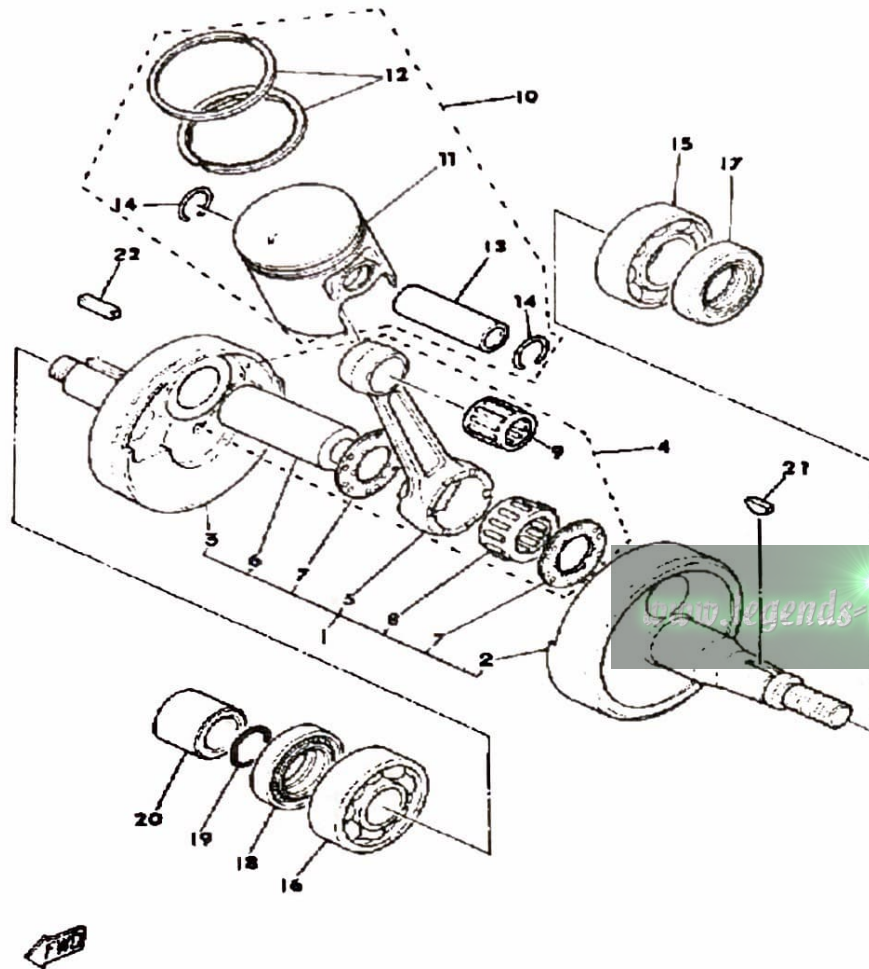

Ref. No.	Part Number	Description	Qty	Remarks
1	2N4-11400-00-00	CRANKSHAFT ASSEMBLY ...	1	
2	1W1-11412-01-00	. CRANK 1	1	
3	(3U5-11650-00-00)	CONNECTING ROD ASSEMBLY	1	ASSEMBLY
	1W1-11422-01-00	. CRANK 2	1	
5	25V-11651-00-00	.. ROD, CONNECTING 1	1	
6	3M5-11681-00-00	.. PIN, CRANK 1	1	
7	90209-22248-00	.. WASHER	2	
8	93310-42277-00	.. BEARING, CYLINDER.#10 (93310-42231)	1	
9	93310-216E1-00	. BEARING	1	
10	(3J1-11630-00-00)	PISTON KIT STD	1	ASSEMBLY
11	3J1-11631-00-96	. PISTON STD	1	
12	2N5-11610-00-00	. PISTON RINGSET STD	1	
13	251-11633-00-00	. PIN, PISTON	1	
14	93450-17044-00	. CIRCLIP	2	
15	93306-20529-00	BEARING (B6205C4)	1	
16	93306-30421-00	BEARING (B6304C3)	1	
17	93102-25061-00	OIL SEAL, SD-TYPE	1	
18	93103-28011-00	OIL SEAL	1	
19	93210-180A6-00	O-RING	1	
20	90387-20488-00	COLLAR	1	
21	90280-03017-00	KEY, WOODRUFF	1	
22	(3J1-11630-10-00)	PISTON KIT 1ST	1	
	(3J1-11630-20-00)	PISTON KIT 2ND	1	
	(3J1-11630-30-00)	PISTON KIT 3RD	1	
	2N5-11610-10-00	PISTON RINGSET 1ST	1	
	2N5-11610-20-00	PISTON RINGSET 2ND	1	
	2N5-11610-30-00	PISTON RINGSET 3RD	1	
	2N5-11610-40-00	PISTON RINGSET 4TH	1	

CONTINUED ON NEXT FRAME ►

CRANKSHAFT - PISTON

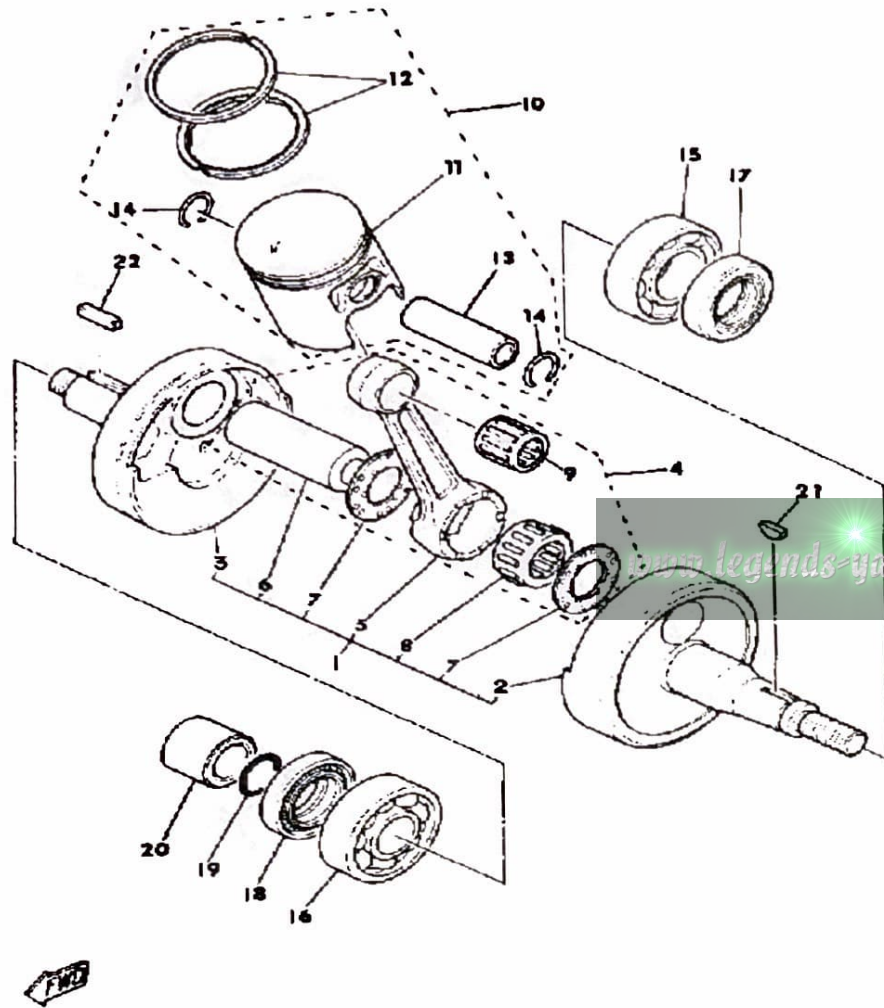

Ref. No.	Part Number	Description	Qty	Remarks
22	3J1-11630-40-00	PISTON KIT 4TH	1	
	3J1-11635-00-00	PISTON 1 O/S 0.5	1	
	3J1-11637-00-00	PISTON 3 O/S 0.5	1	
	3J1-11638-00-00	PISTON 4 O/S 1.0	1	
	90282-05005-00	KEY, STRAIGHT	1	

C - D - I - MAGNETO

Ref. No.	Part Number	Description	Qty	Remarks
1	3J0-85500-21-00	CDI MAGNETO ASSEMBLY	1	
2	(3J0-85550-20-00)	ROTOR ASSEMBLY	1	
3	99999-01515-00	MAGNETO BASE KIT	1	
4	3J0-85512-20-00	COIL SOURCE 2	1	
5	3J0-85513-20-00	COIL, LIGHTING 1	1	
6	3J0-85580-20-00	COIL, PULSER	1	
7	3J0-85515-20-00	LEAD WIRE ASSEMBLY	1	
8	104-81328-20-00	CLAMP	1	
9	98511-04030-00	SCREW, PAN HEAD	2	
10	98503-04014-00	SCREW, PAN HEAD	3	
11	92901-04100-00	WASHER, SPRING	5	
12	97601-04106-00	SCREW, PN/HD.W/WSHR	1	
13	98603-06012-00	SCREW, OVAL HEAD (92701-06012)	2	
14	90170-12347-00	NUT, HEXAGON	1	
15	90201-12593-00	WASHER, PLATE	1	
16	92901-12100-00	WASHER, SPRING	1	
17	3J0-85540-20-00	CDI UNIT ASSEMBLY	1	
18	2A7-85546-00-00	BAND	1	
19	443-81910-62-00	VOLTAGE REG ASSEMBLY (498-81910-23)	1	U.R.
20	97013-06012-00	BOLT	2	
21	92901-06600-00	WASHER	2	
22	1M1-81970-60-00	RECTIFIER ASSEMBLY	1	
23	98580-05020-00	SCREW, PAN HEAD	1	
24	92990-05100-00	WASHER, SPRING	1	
25	92901-05600-00	WASHER, PLATE	1	

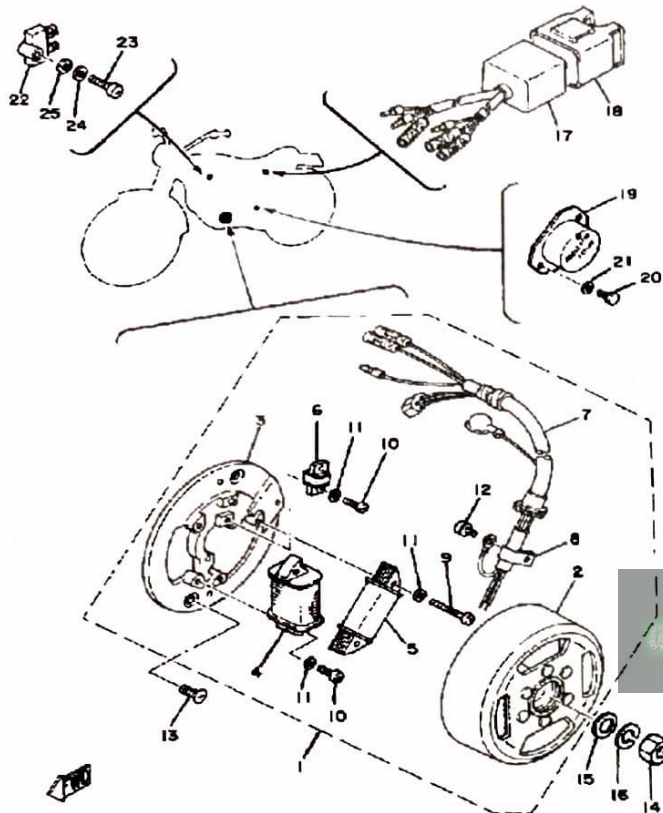

CHARGING SYSTEM	Flywheel Magneto / Single Phase / Half Wave
Battery: Model / Specific Gravity / Charge Rate	GS 6N5-3B-1 (6V 6AH) / 1.26 / 0.6A
Maximum Output	8.7V 2.5A @ 3000 rpm
Charge Coil Color Code / Ω	Grn-Wht ~ Blk / 0.30 Ω ± 10%
IGNITION SYSTEM	Capacitor-Discharge Ignition
Ignition Timing	17.5° BTDC @ 3000 rpm (1.45mm BTDC)
TROUBLESHOOTING	
Ignition Coil Test Gap / Primary Ω / Secondary Ω	0mm / 1.0 Ω ± 10% / 5.0K Ω ± 20%
Pulser Coil or Pickup Coil Color Code / Ω	Wht-Red ~ Blk / 10 Ω ± 10%
Source Coil Color Code / Ω	Brn ~ Blk / 300 Ω ± 10%

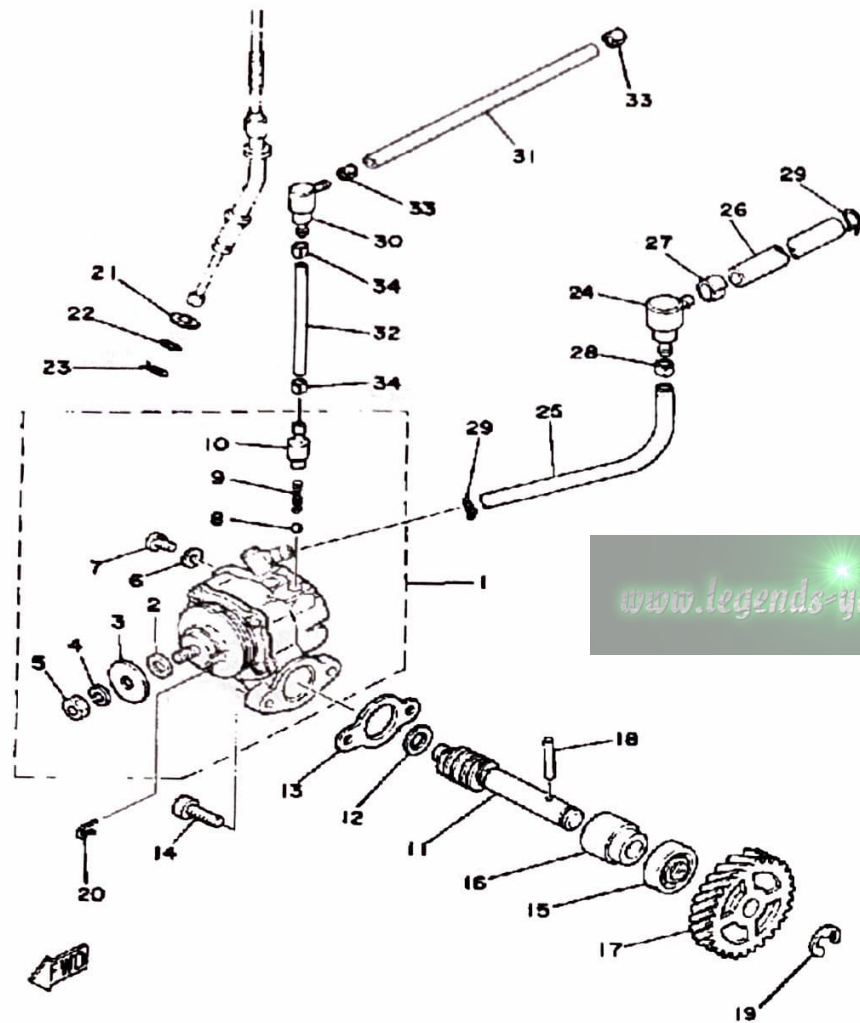

OIL PUMP

Ref. No.	Part Number	Description	Qty	Remarks
1	3J1-13101-00-00	OIL PUMP ASSEMBLY	1	
2	137-13137-00-03	. SHIM (0.3T)	1	U.R.
	137-13137-00-10	. SHIM (1.0T)	1	U.R.
	137-13137-05-00	. UNAVAILABLE IN PRICE BOOK	1	U.R.
3	137-13138-01-00	. PLATE, ADJUSTING	1	
4	92990-05100-00	. WASHER, SPRING	1	
5	95380-05600-00	. NUT	1	
6	90430-04004-00	. GASKET	1	
7	98901-04008-00	. SCREW, BIND	1	
8	93505-32002-00	. BALL	1	
9	90501-02018-00	. SPRING, COMPRESSION	1	
10	402-13552-00-00	. NOZZLE	1	
11	275-13175-01-00	SHAFT, WORM	1	
12	90201-08624-00	WASHER, PLATE	1	
13	3MT-13116-00-00	GASKET, PUMP CASE (8Y0-13116-00)	1	
14	98580-05016-00	SCREW, PAN HEAD	2	
15	93101-10002-00	OIL SEAL	1	
16	1E7-13176-00-00	METAL, WRM SHAF OTR	1	
17	2A6-13178-00-00	GEAR, PUMP DRIVE	1	
18	93603-22028-00	PIN, DOWEL	1	
19	99001-08600-00	CIRCLIP	1	
20	363-13122-01-00	UNAVAILABLE IN PRICE BOOK	1	
21	92901-08600-00	WASHER	1	
22	93210-07100-00	O-RING	1	
23	90468-08086-00	CLIP	1	
24	2A6-13115-01-00	CONNECTOR, SCTN PPE	1	
25	90445-07219-00	HOSE	1	

CONTINUED ON NEXT FRAME ►

OIL PUMP

Ref. No.	Part Number	Description	Qty	Remarks
26	90445-09100-00	HOSE	1	
27	90468-02078-00	CLIP	1	
28	90468-02025-00	CLIP	1	
29	90467-08003-00	CLIP	2	
30	2A6-13164-01-00	CONCT, DELIVERY PPE	1	
31	90445-05024-00	HOSE (835-13171-00)	1	
32	90445-05019-00	HOSE	1	
33	90468-02033-00	CLIP	2	
34	90468-02033-00	CLIP	2	

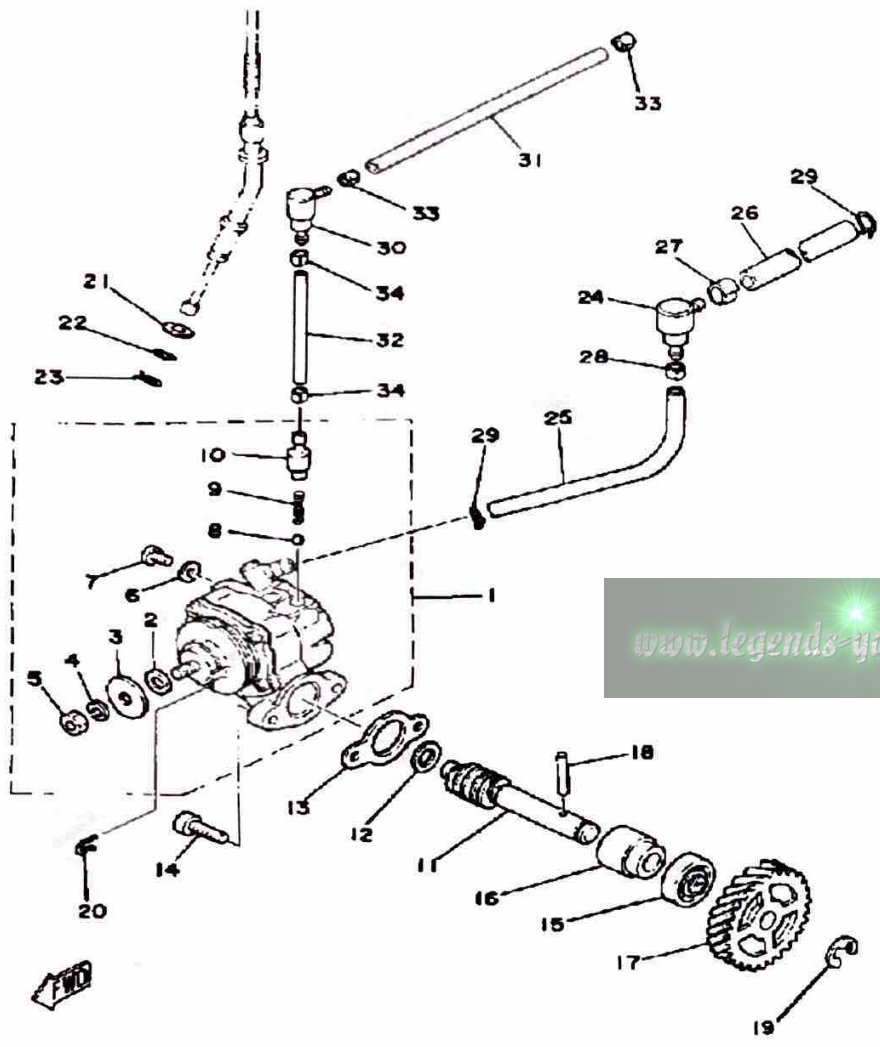

www.legends-yamaha-enduros.com

INTAKE

Ref. No.	Part Number	Description	Qty	Remarks
1	558-13610-00-00	REED VALVE ASSEMBLY	1	
2	345-13613-70-00	. REED, VALVE	2	
3	345-13616-70-00	. STOPPER, REED VALVE	2	
4	98580-03008-00	. SCREW, PAN HEAD	4	
5	87A-13621-00-00	GASKET, VALVE SEAT	1	
6	401-13565-01-00	JOINT, CARBURETOR	1	
7	90460-43053-00	CLAMP, HOSE	1	
8	97011-06025-00	BOLT (97001-06025)	4	
9	92901-06600-00	WASHER	4	
10	90462-05005-00	CLAMP	1	
11	3J0-14411-01-00	CASE, AIR CLEANER 1	1	
12	3J0-14451-01-00	ELEMENT, AIR CLEANER	1	
13	3J0-14458-01-00	. GUIDE	1	
14	99999-01180-00	. GUIDE	1	
15	2X4-14468-00-00	PLATE, ELEMENT FTNG	1	
16	90175-06008-00	NUT, WING	1	
17	3J0-14437-00-00	DUCT	1	
18	3J0-14412-00-00	CAP, CLEANER CASE 1	1	
19	98580-05012-00	SCREW, PAN HEAD	4	
20	92901-05600-00	WASHER, PLATE	4	
21	3J1-14453-00-00	JOINT, AIR CLEANER 1	1	
22	90460-49058-00	CLAMP, HOSE	1	
23	90460-71129-00	CLAMP, HOSE (90460-71017)	1	
24	90480-14023-00	GROMMET	2	
25	90387-07391-00	COLLAR	2	
26	90480-18171-00	GROMMET	1	
27	97011-06025-00	BOLT (97001-06025)	2	
28	92995-06100-00	WASHER, SPRING	2	

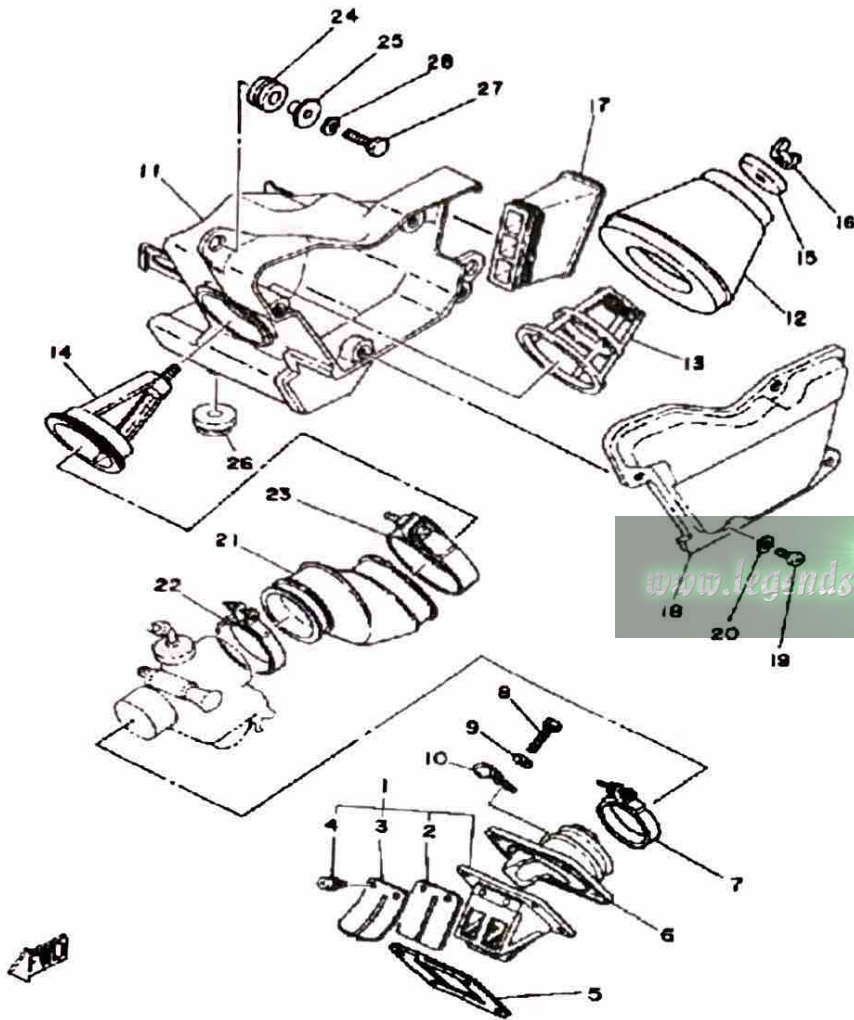

CARBURETOR

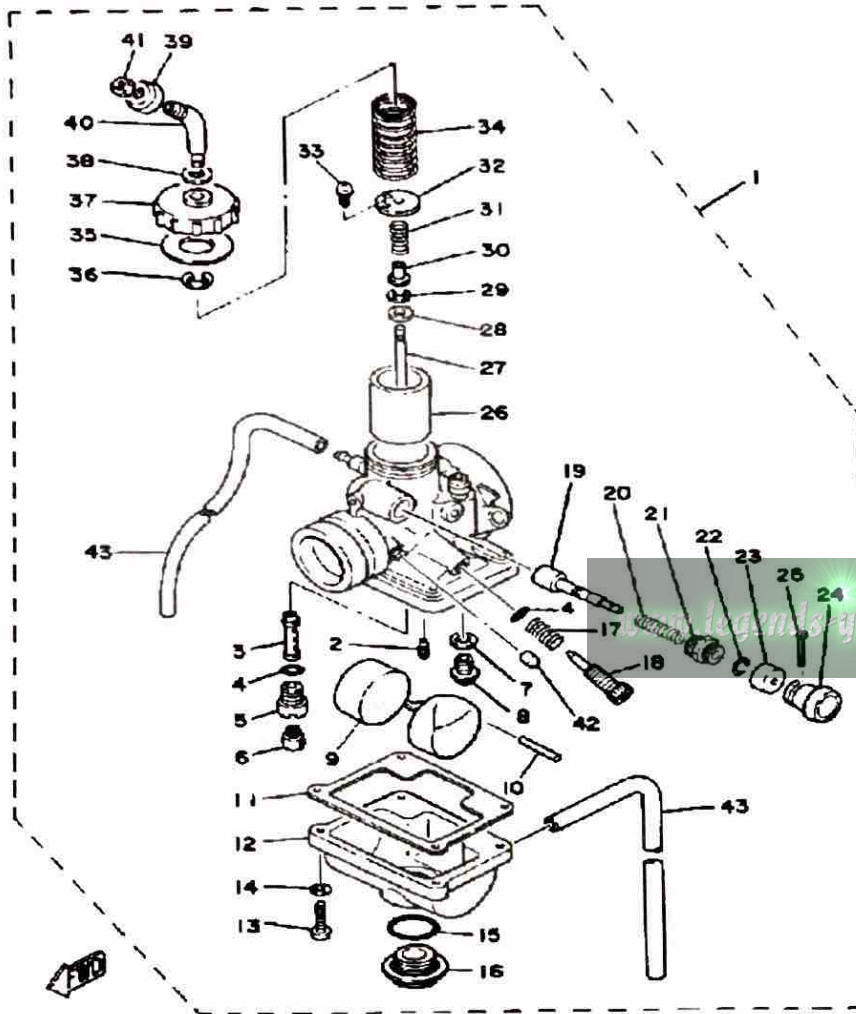

Ref. No.	Part Number	Description	Qty	Remarks
1	3J1-14101-00-00	CARBURETOR ASSEMBLY 1	1	
2	260-14142-22-A0	. JET, PILOT #22 5	1	
3	2F5-14141-24-00	. NOZZLE, MAIN (N-4)	1	
4	214-14147-00-00	. O-RING	1	
5	2N4-14145-00-00	. HOLDER	1	
6	137-14143-30-00	. JET, MAIN #1 0	1	
7	214-14195-00-00	. WASHER, NEEDLE VALVE	1	
8	1V0-14190-25-00	. NEEDLE VALVE ASSEMBLY	1	
9	314-14185-00-00	. FLOAT	1	
10	127-14186-00-00	. PIN, FLOAT	1	
11	304-14184-00-00	. GASKET, FLOAT CHAMBER	1	
12	539-14181-04-00	. BODY, FLOAT CHMBR 1	1	
13	98503-04014-00	. SCREW, PAN HEAD	4	
14	92901-04100-00	. WASHER, SPRING	4	
15	558-14147-00-00	. O-RING	1	
16	500-14115-00-00	. PLUG, SCREW	1	
17	493-14133-00-00	. SPRING, THRTL STOP	1	
18	493-14122-00-00	. SCREW, THROTTLE (443-14122-00)	1	
19	304-14171-00-00	. PLUNGER, STARTER	1	
20	156-14135-00-00	. SPRING, PLUNGER	1	
21	152-14174-00-00	. CAP, PLUNGER	1	
22	353-14138-00-00	. CLIP, PLUNGER	1	
23	3A3-14173-00-00	. COVER, PLUNGER CAP	1	
24	304-14261-00-00	. HOLDER	1	
25	91490-16020-00	. PIN, COTTER	1	
26	(3J1-14112-20-00)	VALVE, THROTTLE 1	1	
27	(452-14116-13-00)	NEEDLE	1	
28	2N6-14918-01-00	. RING	1	

CONTINUED ON NEXT FRAME ►

CARBURETOR

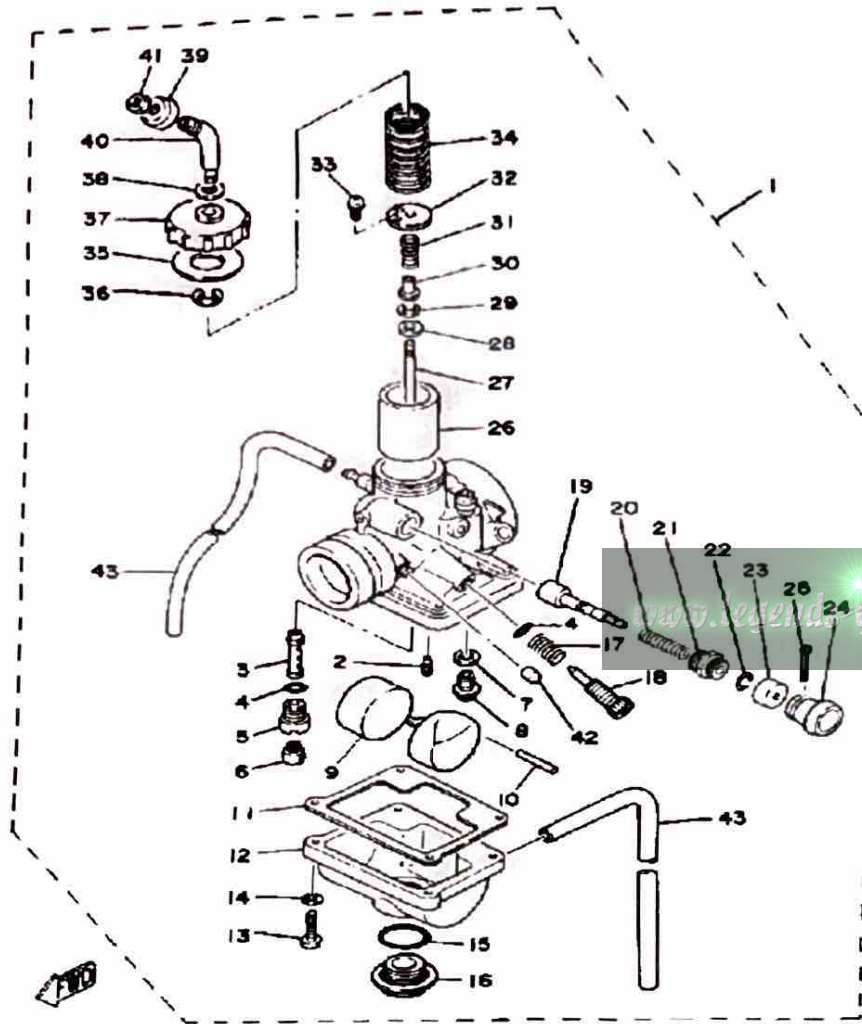

Ref. No.	Part Number	Description	Qty	Remarks
29	164-14137-00-00	. CLIP	1	
30	2N6-14227-01-00	. WASHER	1	
31	(2N6-14589-03-00)	SPRING	1	
32	(3J1-14936-00-00)	SEAT, SPRING	1	
33	98580-03008-00	. SCREW, PAN HEAD	1	
34	2N4-14131-00-00	. SPRING, THRTL VALVE	1	
35	2A6-14126-00-00	. GASKET	1	
36	363-14137-00-00	. CLIP	1	
37	2A6-14158-00-00	. TOP, MIXING CHAMBER	1	
38	509-14198-00-00	. GASKET	1	
39	1M1-14169-00-00	. CAP	1	
40	10X-14106-00-00	. CABLE ADJUST SCREW SET	1	
41	127-14161-00-00	. NUT, CABLE ADJUSTING ...	1	
42	895-14169-00-00	. CAP	1	
43	23F-14197-00-00	. PIPE, AIRVENT	2	

EXHAUST

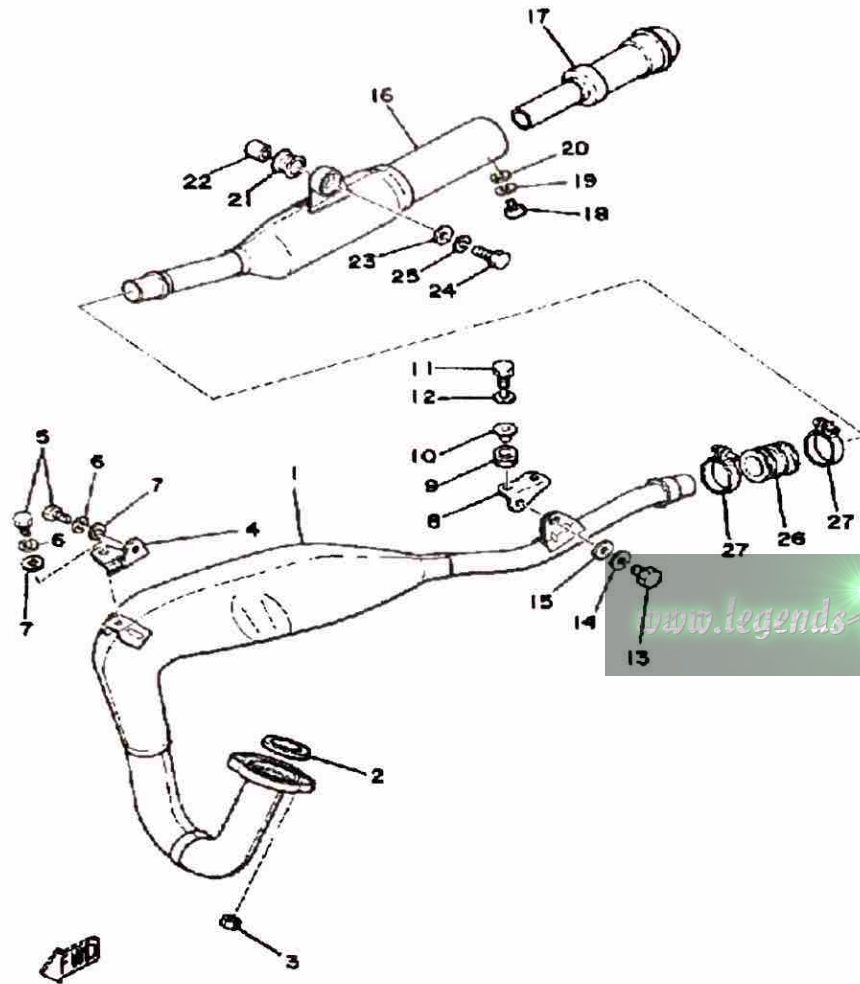

Ref. No.	Part Number	Description	Qty	Remarks
1	3J0-14610-00-00	EXHAUST PIPE ASSEMBLY L (2A6-14610-00)	1	
2	152-14613-00-00	GASKET, EXST PIPE	1	
3	95380-06600-00	NUT	2	
4	2A6-14772-00-00	STAY, MUFFLER 2	1	
5	97313-08018-00	BOLT, HEXAGON (97301-08016)	2	
6	92990-08100-00	WASHER	2	
7	92901-08600-00	WASHER	2	
8	5V7-14771-00-00	STAY, MUFFLER 1	1	
9	90480-14023-00	GROMMET	2	
10	90387-06388-00	COLLAR	2	
11	97011-06025-00	BOLT (97001-06025)	2	
12	92995-06100-00	WASHER, SPRING	2	
13	97313-08018-00	BOLT, HEXAGON (97301-08016)	1	
14	92990-08100-00	WASHER	1	
15	92901-08600-00	WASHER	1	
16	2A6-14753-00-00	SILENCER, EXHAUST	1	
17	1M1-14752-01-00	PIPE, OUTLET	1	
18	98580-06012-00	SCREW, PAN HEAD	1	
19	92995-06100-00	WASHER, SPRING	1	
20	92901-06600-00	WASHER	1	
21	565-14747-00-00	DAMPER, MUFFLER	1	
22	90387-08258-00	COLLAR	1	
23	90201-085E6-00	WASHER PLATE	1	
24	97313-08030-00	BOLT, HEXAGON	1	
25	92990-08100-00	WASHER	1	
26	1W2-14714-00-00	GASKET, MUFFLER	1	
27	90460-37026-00	CLAMP, HOSE	2	

CRANKCASE

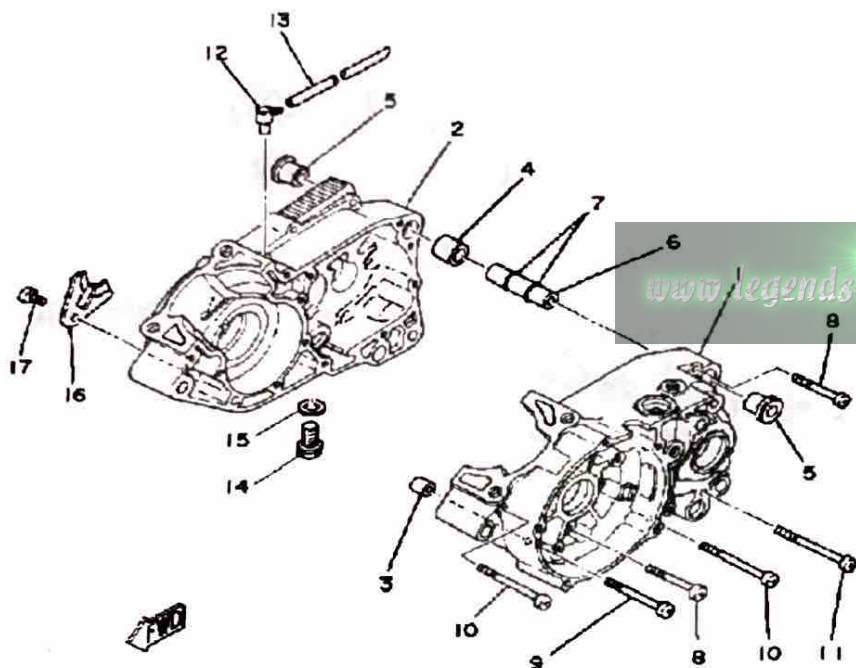
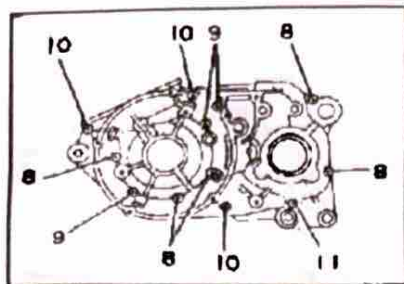

Ref. No.	Part Number	Description	Qty	Remarks
1	(2A6-15111-02-00)	CRANKCASE 1	1	
2	2A6-15121-01-00	CRANKCASE 2	1	
3	99530-10014-00	PIN, DOWEL	1	
4	99510-20020-00	PIN, DOWEL	1	
5	328-15316-00-00	DAMPER, ENG MOUNT 1 (328-15316-00)	2	
6	401-15317-00-00	SPACER, ENG MOUNT	1	
7	93210-11073-00	O-RING	2	
8	98580-06550-00	SCREW PAN HEAD (92503-06050)	5	
9	92580-06560-00	SCREW PAN HEAD	3	
10	98501-06070-00	SCREW, PAN HEAD	3	
11	98501-06075-00	SCREW, PAN HEAD	1	
12	2N4-15371-00-00	BREATHER	1	
13	90445-07340-00	HOSE	1	
14	90340-12005-00	PLUG, DRAIN	1	
15	90430-12207-00	GASKET	1	
16	304-15128-00-00	HOLDER	1	
17	92501-08010-00	SCREW, PAN HEAD	1	

CRANKCASE COVER

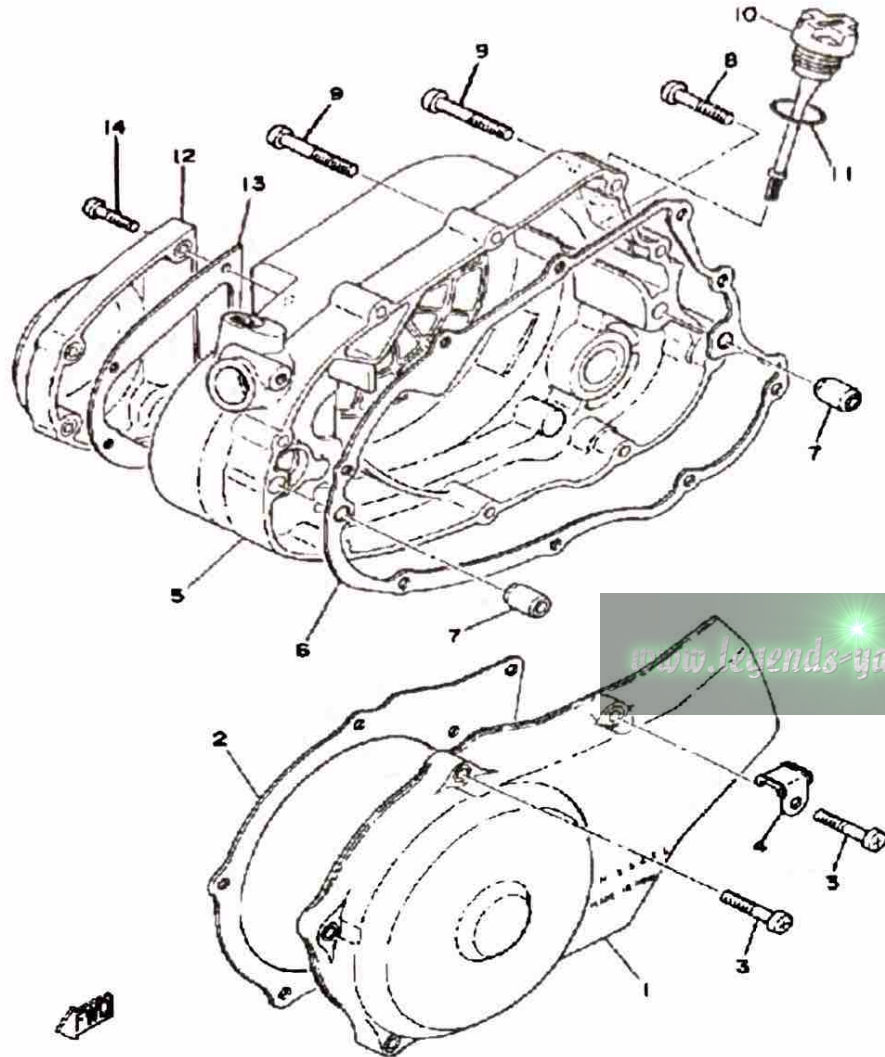

Ref. No.	Part Number	Description	Qty	Remarks
1	2A7-15411-01-00	COVER, CRANKCASE L	1	
2	2A6-15455-01-00	GASKET 1	1	
3	98511-06025-00	SCREW PAN HEAD (92501-06025)	6	
4	2A6-15484-01-00	CLAMP 2	1	
5	2A6-15431-00-00	COVER, CRANKCASE 3	1	
6	18G-15451-01-00	GASKET, CRCS. COVER	1	
7	99530-10014-00	PIN, DOWEL	2	
8	98580-06030-00	SCREW PAN HEAD	3	
9	98580-06040-00	SCREW, pan head (92501-06040-00)	6	
10	18G-15362-00-00	PLUG, OIL LEVEL	1	
11	93210-21190-00	O-RING	1	
12	2A6-15416-00-00	COVER, OIL PUMP	1	
13	2A6-15456-00-00	GASKET, O/PMP CVR 1	1	
14	98511-06025-00	SCREW PAN HEAD (92501-06025)	4	

www.legends-yamaha-enduros.com

KICK - STARTER

Ref. No.	Part Number	Description	Qty	Remarks
1	2A6-15660-01-00	KICK AXLE ASSEMBLY	1	
2	1W1-15641-00-00	GEAR, KICK (27T)	1	
3	90468-26048-00	CLIP	1	
4	248-15654-00-00	HOLDER, KICK GEAR	2	
5	99009-30400-00	CIRCLIP	1	
6	401-15676-00-00	COVER, SPRING	1	
7	90508-26346-00	SPRING, TORSION	1	
8	1W1-15666-00-00	SPACER	1	
9	525-15651-00-00	GEAR, KICK IDLE (25T)	1	
10	137-17417-00-05	SHIM 1 (0.5T)	2	
11	93440-15012-00	CIRCLIP	2	
12	2A6-15620-01-00	KICK CRANK ASSEMBLY	1	
13	1W1-15621-01-00	BOSS, KICK CRANK	1	
14	90501-10459-00	SPRING, COMPRESSION	1	
15	93503-16010-00	BALL	1	
16	90201-12541-00	WASHER, PLATE	1	
17	93430-08007-00	CIRCLIP	1	
18	156-15618-01-00	COVER, KICK LEVER	1	
19	1W1-15618-01-00	COVER, KICK LEVER	1	
20	91316-08025-00	BOLT, SOCKET HEAD	1	
21	93101-17062-00	OIL SEAL	1	

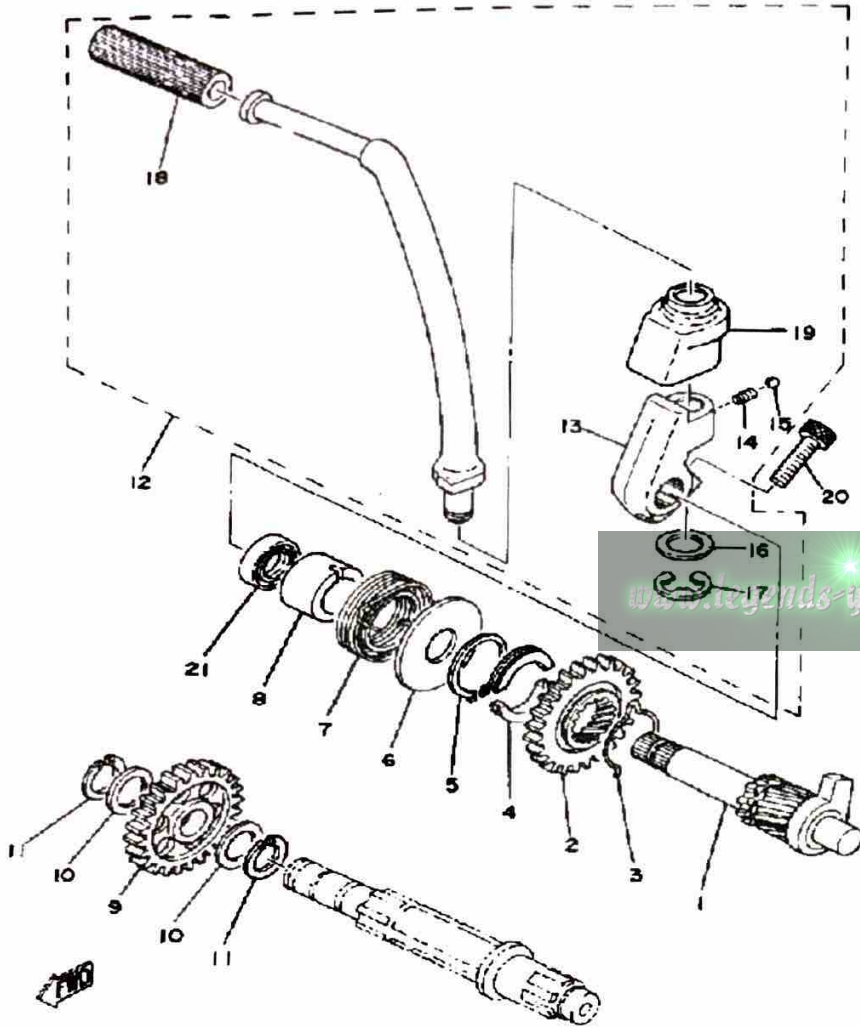

CLUTCH

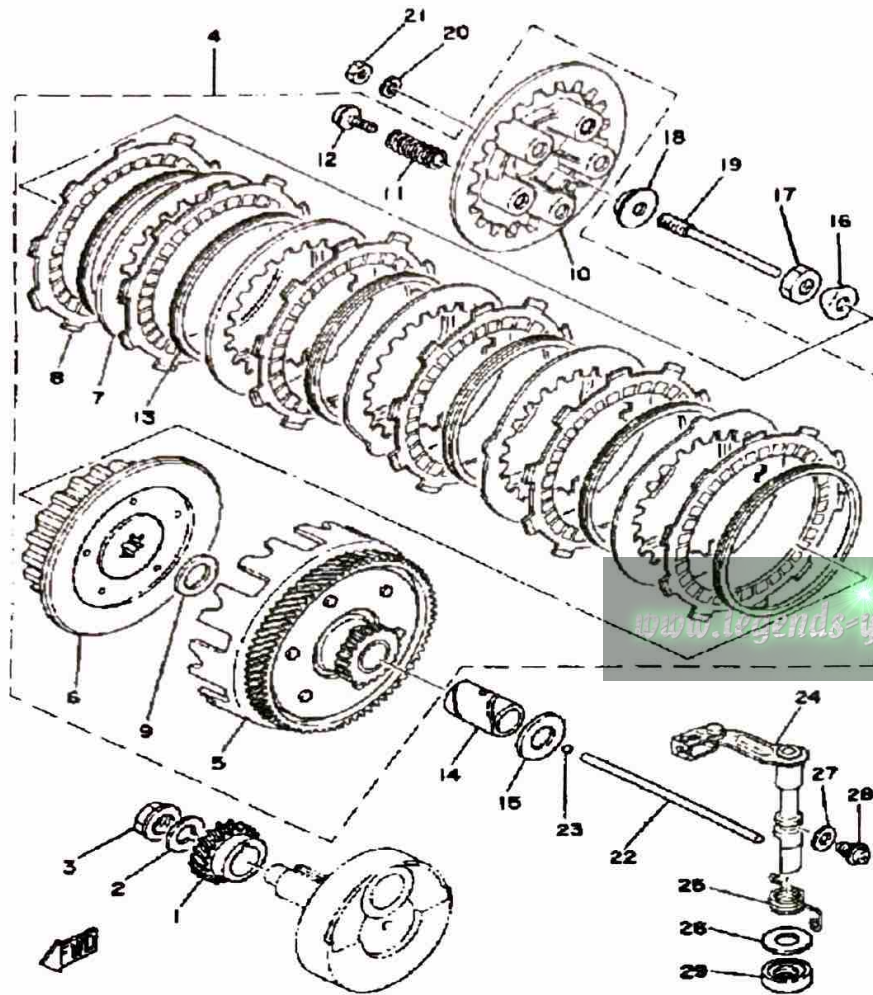

Ref. No.	Part Number	Description	Qty	Remarks
1	2A6-16111-00-00	GEAR, PRI DRIVE	1	
2	90204-12007-00	WASHER, SPRING	1	
3	90179-12244-00	NUT, SPEC'L SHAPE	1	
4	3J1-16300-00-00	CLUTCH ASSEMBLY CLUTCH ASSEMBLY (2A7-16301-00)	1	
5	1W1-16150-01-00	PRIMARY DRIVEN GEAR COMP. (71T)	1	
6	1G8-16371-00-00	BOSS, CLUTCH	1	
7	2A6-16324-00-00	PLATE, CLUTCH 1	5	
8	559-16321-01-00	PLATE, FRICTION	6	
9	90201-174E1-00	WASHER, PLATE	1	
10	1W1-16351-00-00	PLATE, PRESSURE 1	1	
11	90501-20474-00	SPRING, COMPRESSION	5	
12	90159-05011-00	SCREW, WITH WASHER	5	
13	307-16367-00-00	RING, CUSHION	6	
14	90560-17147-00	SPACER	1	
15	90201-174E1-00	WASHER, PLATE	1	
16	90215-14204-00	WASHER, LOCK	1	
17	90170-14171-00	NUT	1	
18	30X-16358-00-00	PLATE, PUSH	1	
19	1W1-16356-02-00	ROD, PUSH 1	1	
20	92990-06200-00	WASHER	1	
21	95380-06600-00	NUT	1	
22	2X3-16357-00-00	ROD, PUSH 2	1	
23	93503-16010-00	BALL	1	
24	2X3-16380-01-00	PUSH LEVER ASSEMBLY	1	
25	90508-20345-00	SPRING, TORSION	1	
26	90201-14217-00	WASHER, PLATE	1	
27	90430-08069-00	GASKET	1	

CONTINUED ON NEXT FRAME ►

CLUTCH

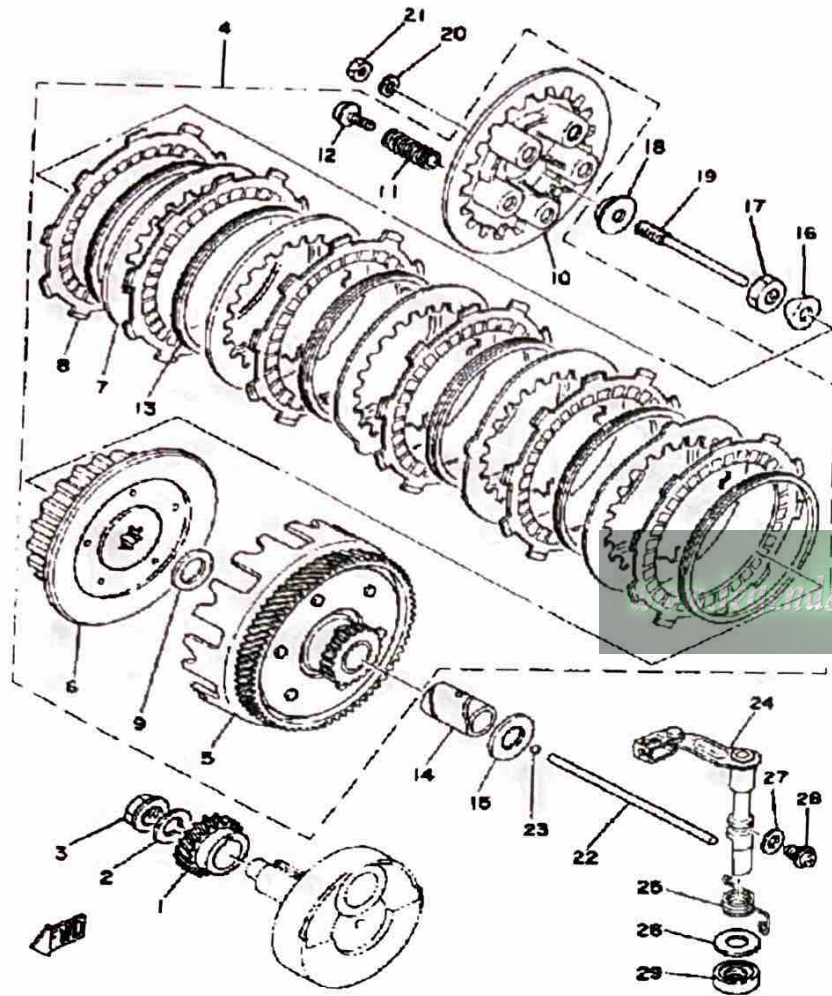

Ref. No.	Part Number	Description	Qty	Remarks
28	90149-08108-00	SCREW, SPEC"L SHAPE	1	
29	93104-14059-00	OIL SEAL, SO-TYPE	1	

TRANSMISSION

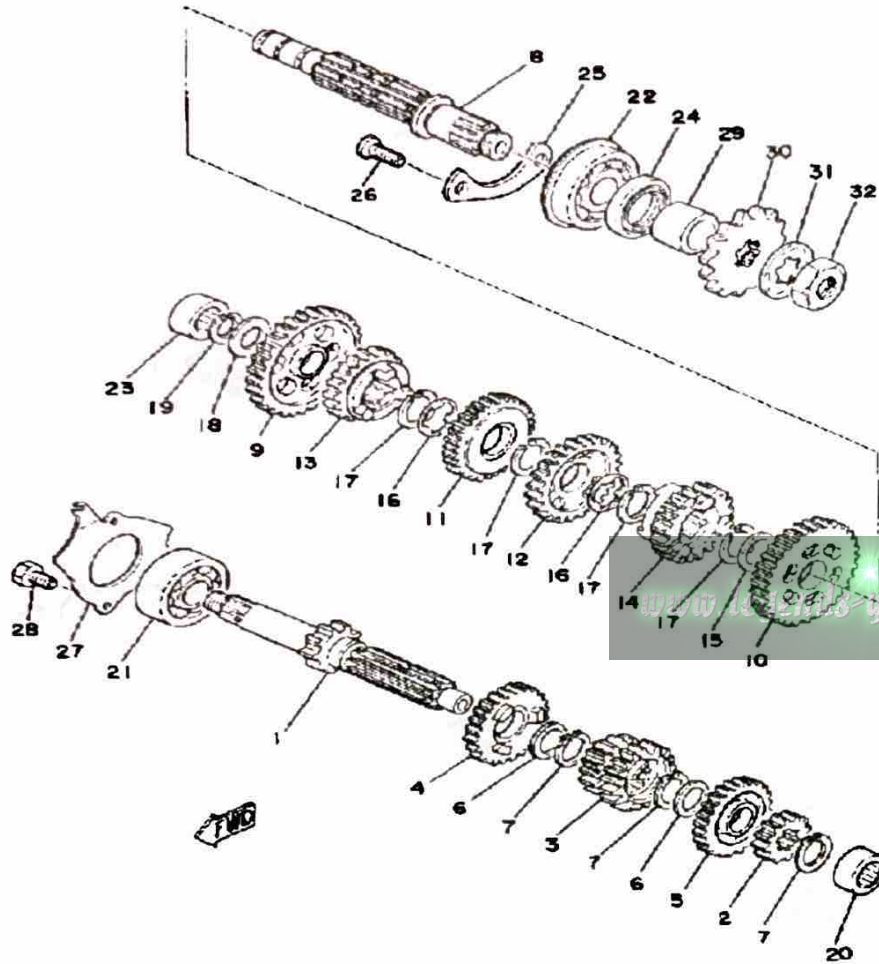

Ref. No.	Part Number	Description	Qty	Remarks
1	2A6-17411-00-00	AXLE, MAIN	1	
2	2A6-17121-00-00	GEAR, 2ND PINION	1	
3	2A6-17131-00-00	GEAR, 3RD PINION	1	
4	1W2-17151-00-00	GEAR, 5TH PINION	1	
5	1W2-17161-00-00	GEAR, 6TH PINION	1	
6	90201-20266-00	WASHER, PLATE (1.0T)	2	
7	93410-20038-00	CIRCLIP	3	
8	2A6-17421-00-00	AXLE, DRIVE	1	
9	2A6-17211-01-00	GEAR, 1ST WHEEL (2A6-17211-00)	1	
10	2A6-17221-01-00	GEAR, 2ND WHEEL (2A6-17221-00)	1	
11	2A6-17231-00-00	GEAR, 3RD WHEEL	1	
12	1W2-17241-00-00	GEAR, 4TH WHEEL	1	
13	2A6-17251-00-00	GEAR, 5TH WHEEL	1	
14	2A6-17261-00-00	GEAR, 6TH WHEEL	1	
15	90201-22555-00	WASHER, PLATE	1	
16	90209-18135-00	WASHER	2	
17	93410-22039-00	CIRCLIP	4	
18	90201-15701-00	WASHER, PLATE (1.0T)	1	
19	93440-15012-00	CIRCLIP	1	
20	93311-41530-00	BEARING	1	
21	93306-30309-00	BEARING	1	
22	93306-30411-00	BEARING (B6304)	1	
23	93311-31567-00	BEARING, CYLINDRICAL	1	
24	93102-26042-00	OIL SEAL	1	
25	1W1-15381-00-00	PLATE, BRNG COVER	1	
26	98603-06012-00	SCREW, OVAL HEAD (92701-06012)	2	
27	1W1-17471-01-00	PLATE, COVER	1	

CONTINUED ON NEXT FRAME ►

TRANSMISSION

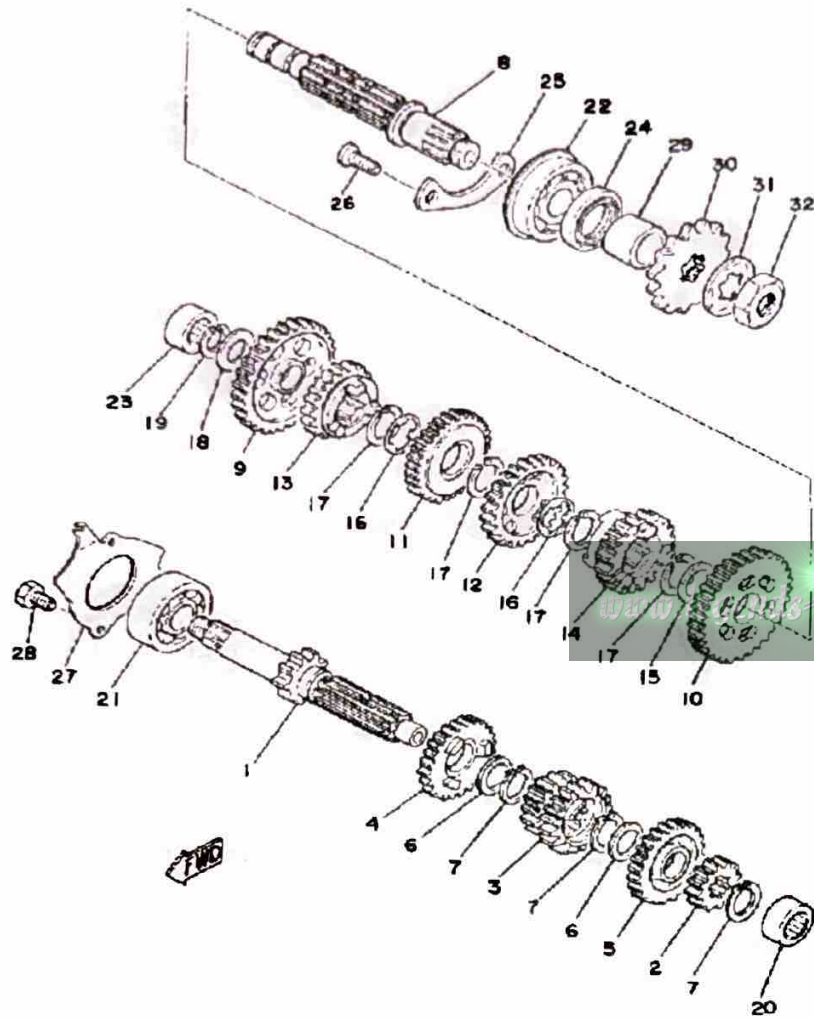

Ref. No.	Part Number	Description	Qty	Remarks
28	97013-06012-00	BOLT	2	
29	90387-202A0-00	COLLAR	1	
30	93822-16093-00	SPROCKET, DRIVE	1	
31	90215-16127-00	WASHER, LOCK	1	
32	90179-16226-00	NUT	1	

TACHOMETER GEAR

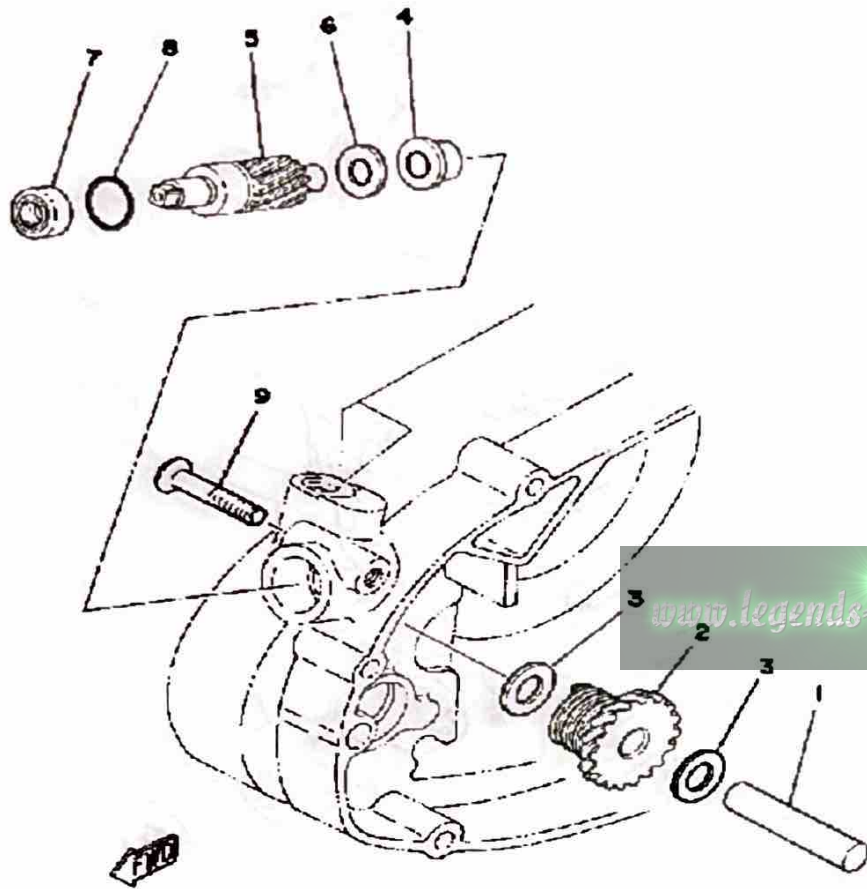

Ref. No.	Part Number	Description	Qty	Remarks
1	(248-17861-00-00)	AXLE, DRIVE GEAR	1	
2	2A6-17831-00-00	GEAR, DRIVE	1	
3	90201-10123-00	WASHER, PLATE (10.5-18-1.6) (256-21715-00) 0 2	2	
4	90381-08002-00	BUSHING (214-17843-00)	1	
5	(2A6-17841-00-00)	GEAR, DRIVEN	1	
6	90201-12M34-00	WASHER, PLATE	1	
7	93102-08307-00	OIL SEAL	1	
8	93210-14104-00	O-RING	1	
9	92601-06030-00	SCREW, OVAL HEAD	1	

SHIFT CAM - FORK

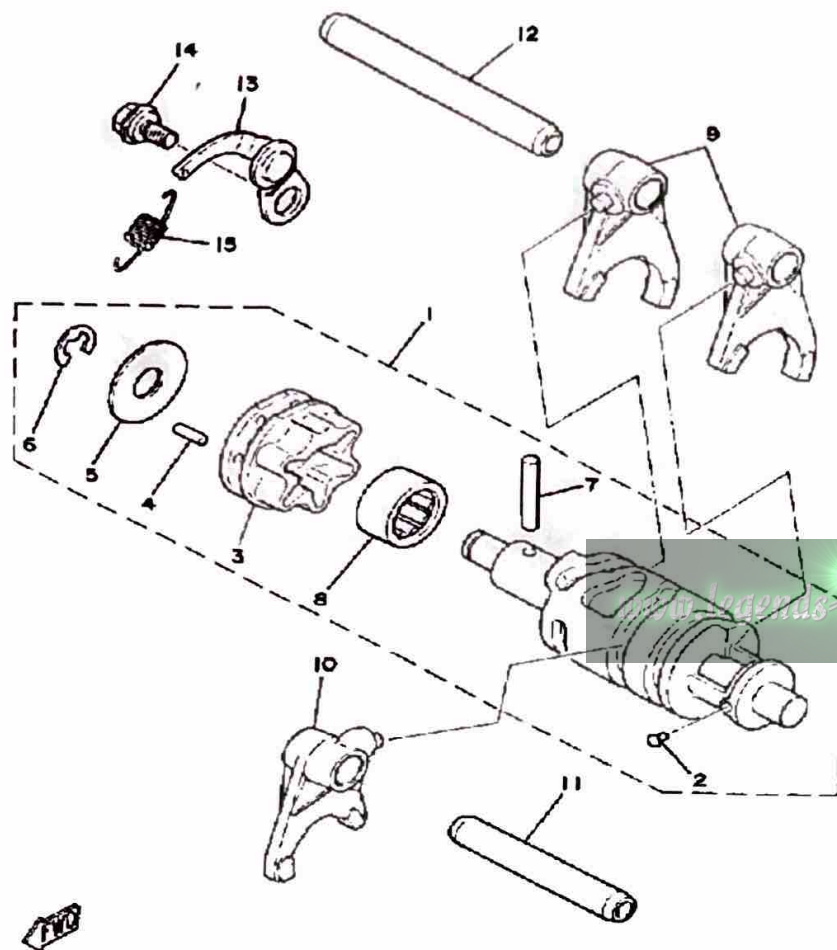

Ref. No.	Part Number	Description	Qty	Remarks
1	1W1-18540-00-00	SHIFT CAM ASSEMBLY	1	
2	136-18542-00-00	. POINT, NEUTRAL	1	
3	1W1-18185-00-00	. SEGMENT	1	
4	93604-12037-00	. PIN, DOWEL	6	
5	1W1-18561-00-00	. PLATE, SIDE 1	1	
6	99001-08600-00	. CIRCLIP	1	
7	93604-30018-00	. PIN, DOWEL	1	
8	93315-21813-00	. BEARING	1	
9	2A6-18511-00-00	FORK, SHIFT 1	2	
10	2A6-18512-00-00	FORK, SHIFT 2	1	
11	2A6-18531-00-00	BAR, SHIFT FORK GUIDE 1	1	
12	2A6-18535-00-00	BAR, SHIF FRK GDE 2	1	
13	1W1-18140-00-00	STOPPER LEVER ASSEMBLY	1	
14	50W-21631-00-00	BOLT 1	1	
15	90506-09156-00	SPRING, TENSION	1	

SHIFT SHAFT - PEDAL

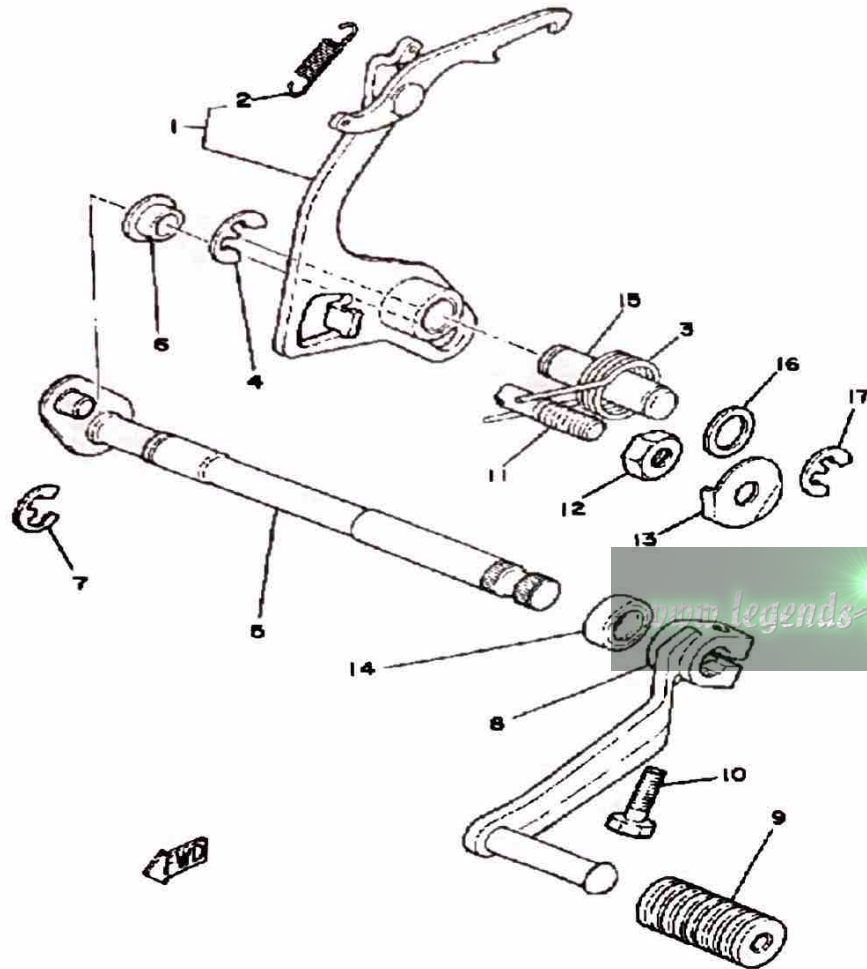

Ref. No.	Part Number	Description	Qty	Remarks
1	4F2-18120-00-00	SHIFT LEVER ASSEMBLY (2A6-18120-00)	1	
2	90506-08155-00	SPRING, TENSION	1	
3	90508-32349-00	SPRING, TORSION	1	
4	99006-10600-00	CIRCLIP	1	
5	1W1-18101-03-00	SHIFT SHAFT ASSEMBLY 1	1	
6	401-18178-00-00	ROLLER, SHIFT LEVER	1	
7	99006-10600-00	CIRCLIP	1	
8	2A6-18111-00-00	PEDAL, SHIFT	1	
9	132-18113-01-00	COVER, SHIFT PEDAL	1	
10	97011-06020-00	BOLT	1	
11	90149-08111-00	SCREW, SPEC'L SHAPE	1	
12	90170-08029-00	NUT	1	
13	90215-08014-00	WASHER, LOCK	1	
14	93101-12060-00	OIL SEAL	1	
15	1W1-18197-01-00	SHAFT	1	
16	90201-12M34-00	WASHER, PLATE	1	
17	99006-10600-00	CIRCLIP	1	

FRAME - TOOL

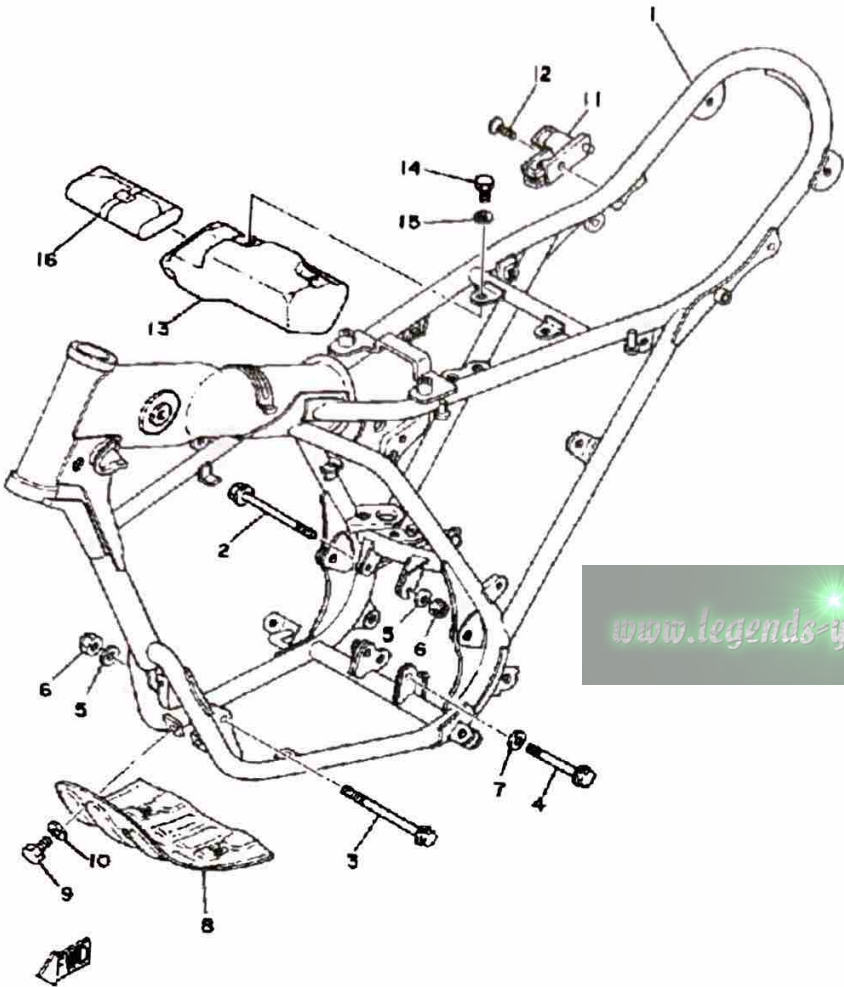

Ref. No.	Part Number	Description	Qty	Remarks
1	(3J0-21110-00-33)	FRAME	1	YAMAHA BLACK
2	90105-08099-00	BOLT, WASHER BASED	1	
3	90105-08120-00	BOLT, WASHER BASED	1	
4	90105-10037-00	BOLT, WASHER BASED	1	
5	92990-08200-00	WASHER, PLAIN	2	
6	90185-08089-00	NUT, SELF-LOCKING	2	
7	92990-10100-00	WASHER, SPRING	1	
8	(2A6-21471-00-90)	PROTECTOR, ENGINE	1	UNI CHROME (BLK)
9	97013-06012-00	BOLT	4	
10	92901-06600-00	WASHER	4	
11	55E-21308-00-00	HELMET HANGER ASSEMBLY	1	
12	98603-06018-00	SCREW, OVAL HEAD	1	
13	3J0-21170-00-00	BOX	1	
14	97013-06012-00	BOLT	2	
15	92901-06600-00	WASHER	2	
16	2A6-W2810-00-00	TOOL KIT	1	

www.legends-yamaha.com

FRONT FENDER - REAR FENDER

Ref. No.	Part Number	Description	Qty	Remarks
1	3J4-21511-00-00	FENDER, FRONT	1	CLEAN WHITE
2	90201-06067-00	WASHER, PLATE	4	
3	90480-14198-00	GROMMET	4	
4	90387-06388-00	COLLAR	4	
5	97011-06025-00	BOLT (97001-06025)	4	
6	92995-06100-00	WASHER, SPRING	4	
7	2A8-21611-80-00	FENDER, REAR	1	CLEAN WHITE
8	2A6-21617-01-00	BRACKET, FENDER (2A6-21617-00)	1	
9	97313-06016-00	BOLT, HEXAGON	4	
10	92995-06100-00	WASHER, SPRING	4	
11	92901-06600-00	WASHER	4	
12	(99999-01151-00)	GUARD, MUD	1	
13	2A6-21639-00-00	. DAMPER 2	1	
14	1M1-21621-00-00	FLAP	1	
15	90480-01254-00	GROMMET	2	
16	90201-06067-00	WASHER, PLATE	3	
17	97313-06016-00	BOLT, HEXAGON	3	
18	92995-06100-00	WASHER, SPRING	3	

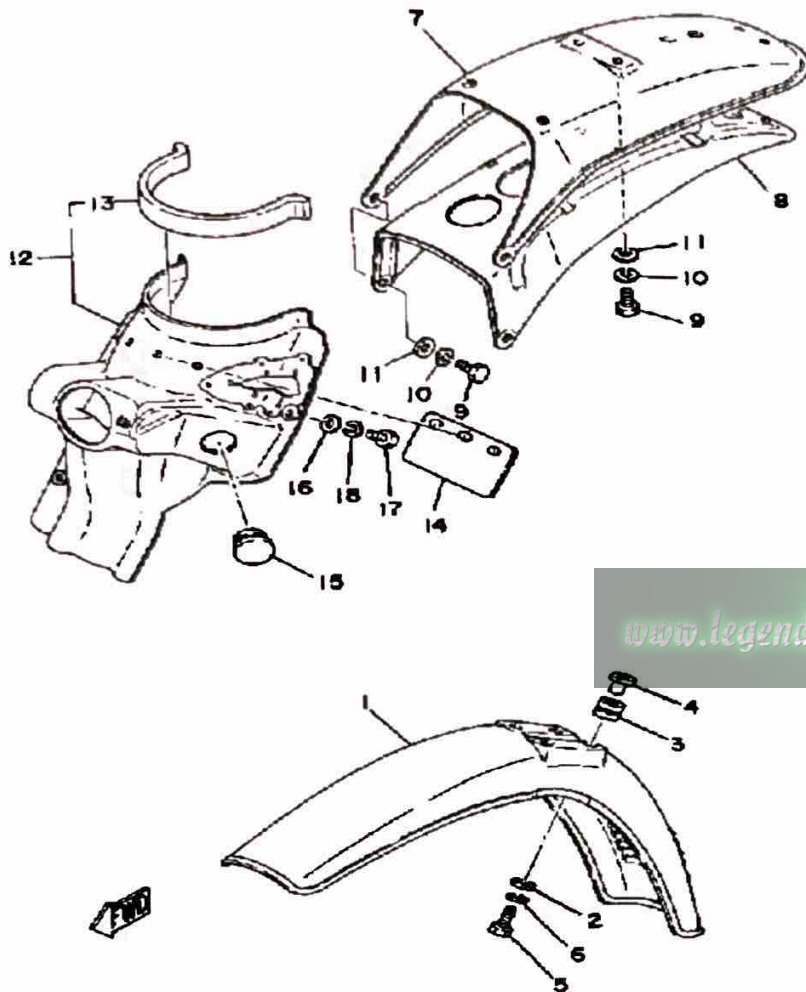

SIDE COVER

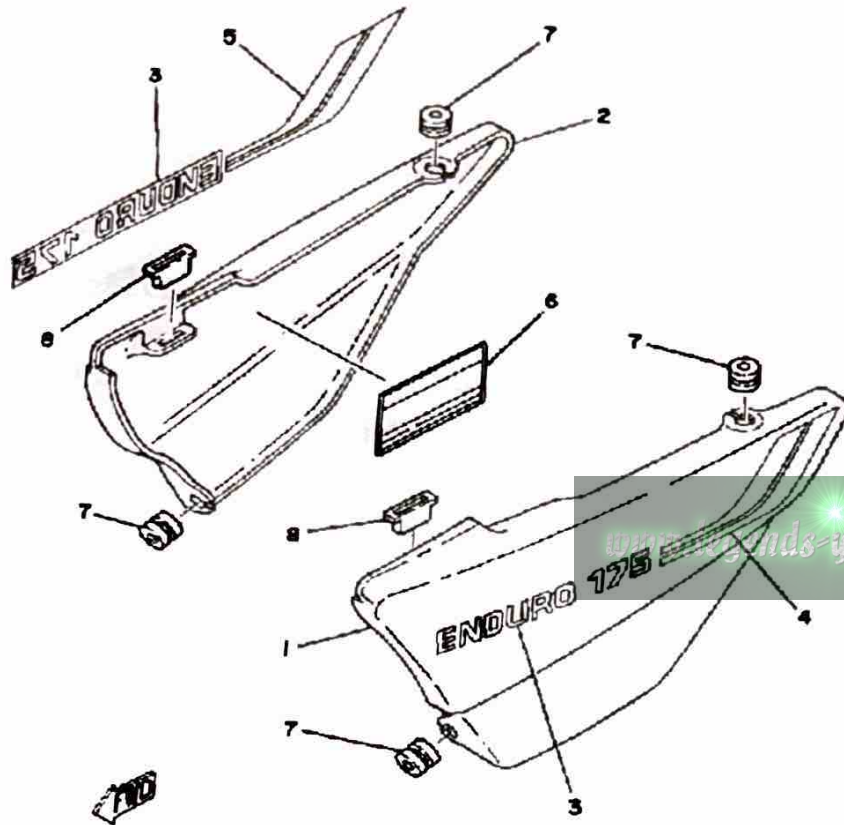

Ref. No.	Part Number	Description	Qty	Remarks
1	2N4-21711-01-E1	COVER, SIDE 1	1	CHAPPY RED
2	2N4-21721-01-E1	COVER, SIDE 2	1	CHAPPY RED
3	3J1-21786-10-00	EMBLEM 6 (2N5-21786-00) ...	2	
4	(3J0-21784-00-00)	EMBLEM 4	1	
5	3J0-21785-00-00	EMBLEM 5	1	
6	(3J1-21683-10-00)	PLATE, SPEC	1	
7	90480-12053-00	GROMMET	4	
8	2N4-21717-00-00	DAMPER	2	

OIL TANK

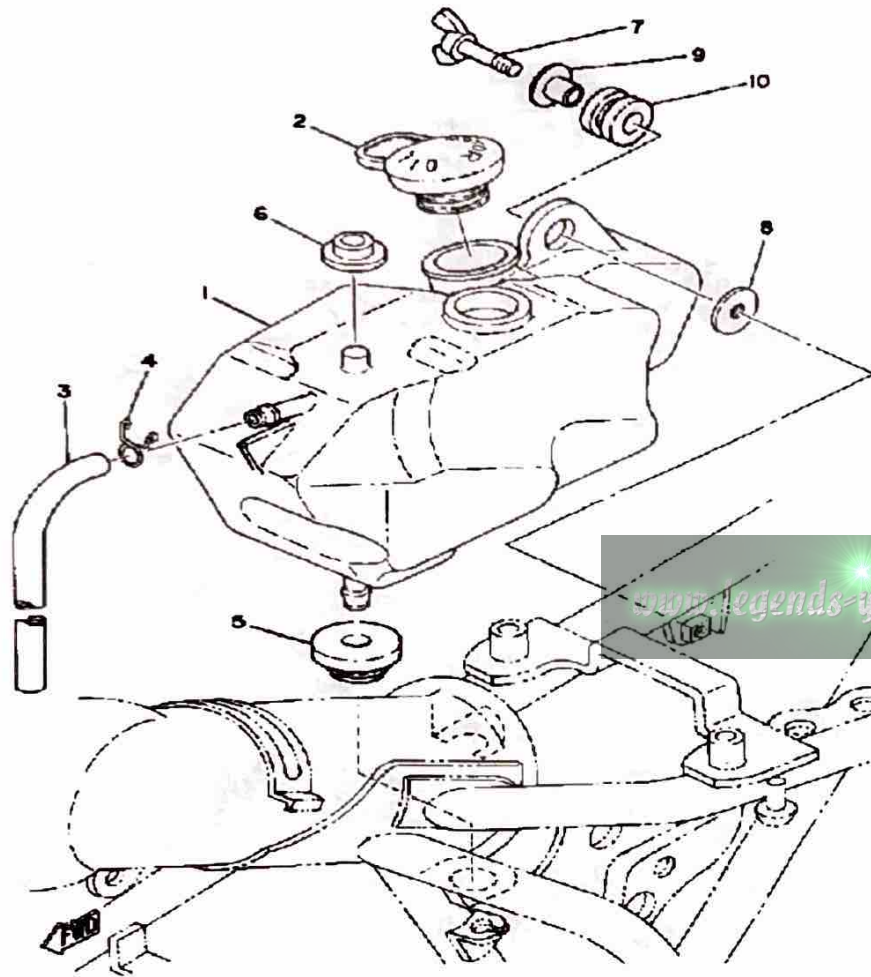

Ref. No.	Part Number	Description	Qty	Remarks
1	3J0-21751-00-00	TANK, OIL	1	
2	1T9-21771-00-00	BODY, CAP	1	
3	90445-09282-00	HOSE	1	
4	90467-08003-00	CLIP	1	
5	90480-18171-00	GROMMET	1	
6	90480-13253-00	GROMMET	1	
7	90122-06021-00	BOLT, WING (38W)	1	
8	90179-06013-00	NUT, SPEC'L SHAPE	1	
9	90387-07391-00	COLLAR	1	
10	90480-14023-00	GROMMET	1	

www.legends-yamaha-enduros.com

REAR ARM

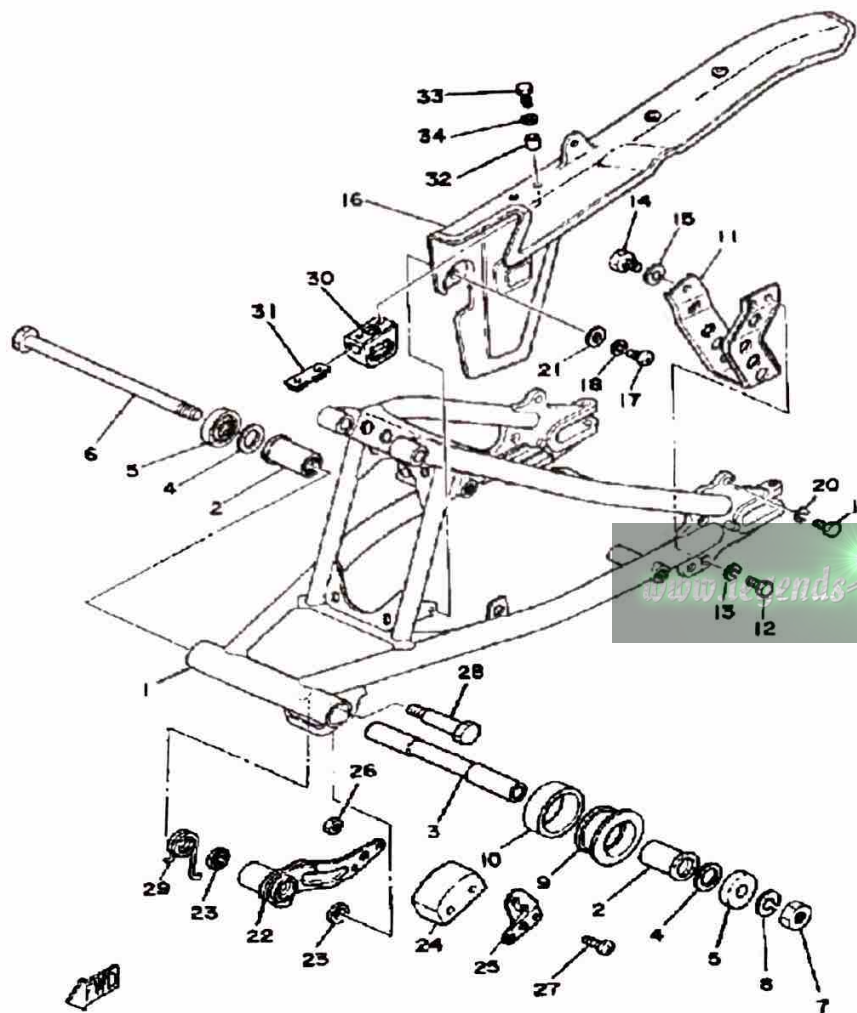

Ref. No.	Part Number	Description	Qty	Remarks
1	(2A6-22110-01-33)	REAR ARM	1	YAMAHA BLACK
2	90386-18028-00	BUSH	2	
3	18G-22124-00-00	BUSH 2	1	
4	401-22127-00-00	SHIM	1	U.N.
5	401-22128-01-00	SEAL, GUARD	2	
6	2N4-22141-00-00	SHAFT, PIVOT	1	
7	90185-12046-00	NUT, SELF-LOCKING	1	
8	92901-12100-00	WASHER, SPRING	1	
9	2A6-22151-00-00	SEAL, GUARD	1	
10	2A6-22152-00-00	SEAL, GUARD	1	
11	2A6-22318-00-00	GUARD, CHAIN	1	
12	97313-06016-00	BOLT, HEXAGON	2	
13	92995-06100-00	WASHER, SPRING	2	
14	97313-08012-00	BOLT	1	
15	92990-08100-00	WASHER	1	
16	2A6-22311-01-00	CASE, CHAIN	1	
17	98580-05016-00	SCREW, PAN HEAD	2	
18	92990-05100-00	WASHER, SPRING	2	
19	97313-05012-00	BOLT, HEXAGON	1	
20	92990-05100-00	WASHER, SPRING	1	
21	90201-05036-00	WASHER, PLATE	2	
22	2A6-22179-00-00	ARM, TENSIONER	1	
23	93104-14044-00	OIL SEAL	2	
24	ACC-11130-00-25	TENSIONER (2N0-22178-00-00)	1	
25	1W1-22187-00-00	GUIDE, CHAIN	1	
26	95311-05700-00	NUT	2	
27	98501-05035-00	SCREW, PAN HEAD	2	
28	90109-10483-00	BOLT (90109-10533-00)	1	
29	90508-35350-00	SPRING, TORSION	1	

CONTINUED ON NEXT FRAME ►

REAR ARM

Ref. No.	Part Number	Description	Qty	Remarks
30	3J0-22147-00-00	PROTECTOR, CHAIN	1	
31	3J0-22131-00-00	STAY, CHAIN CASE 1	1	
32	90387-05682-00	COLLAR	2	
33	97313-05016-00	BOLT, HEXAGON	2	
34	92901-05600-00	WASHER, PLATE	2	

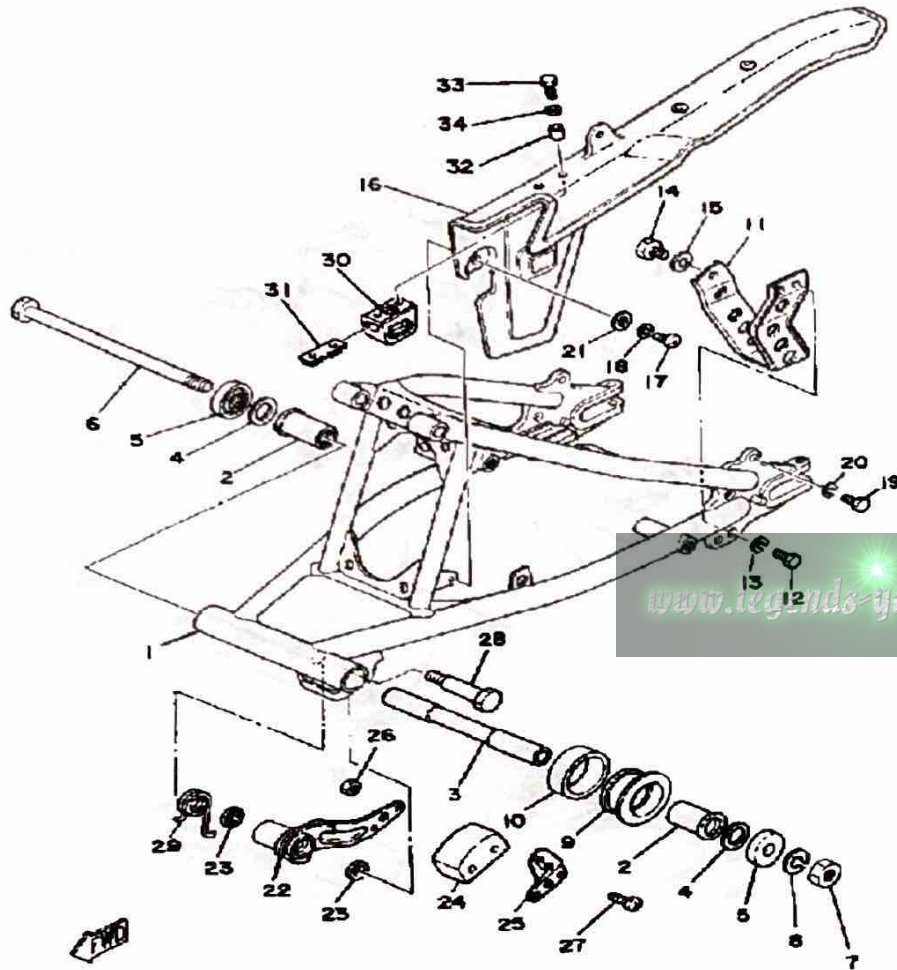

REAR SUSPENSION

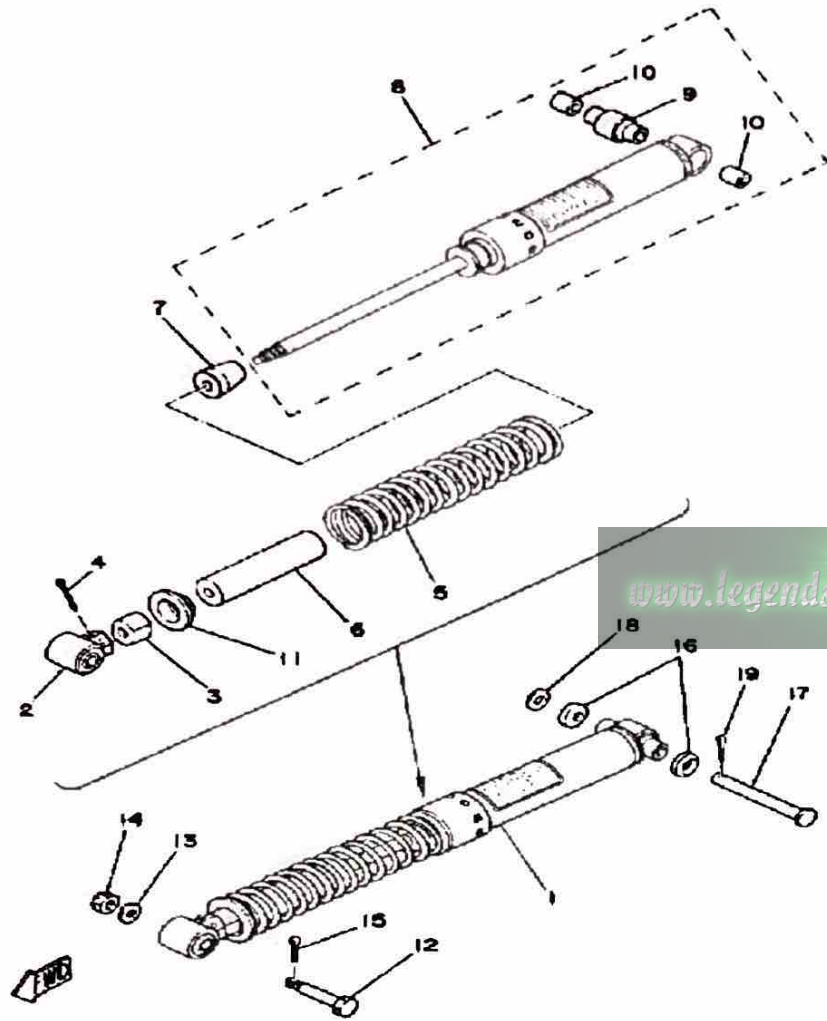

Ref. No.	Part Number	Description	Qty	Remarks
1	(2N4-22210-01-00)	SHK/ABS ASSEMBLY, REAR	1	
2	(1M1-22219-01-00)	BRACKET, UPPER	1	
3	(2N4-22213-00-00)	SEAT, SPRING UPPER	1	
4	91401-30040-00	. PIN, COTTER	1	
5	(90501-90514-00)	SPRING, COMPRESSION	1	
6	(2N4-22496-00-00)	SLEEVE, ROD	1	
7	(2A6-22493-00-00)	BUMP, STOP	1	
8	(2N4-22401-01-00)	DAMPER SUB-ASSEMBLY.	1	
9	1W1-22226-00-00	.. BUSH, SHOCK ABS LWR	1	
10	90380-12051-00	.. BUSH, SOLID	2	
11	(2N4-22214-00-00)	GUIDE, SPRING 1	1	
12	90109-10550-00	BOLT (90109-10453-00)	1	
13	92990-10200-00	WASHER, PLAIN	1	
14	95303-10700-00	NUT	1	
15	91490-20025-00	PIN, SPLIT	1	
16	1W1-22128-00-00	COVER, THRUST 1	2	
17	90240-12059-00	PIN, CLEVIS	1	
18	92990-12600-00	WASHER, PLATE	1	
19	91401-30030-00	PIN, COTTER	1	

STEERING

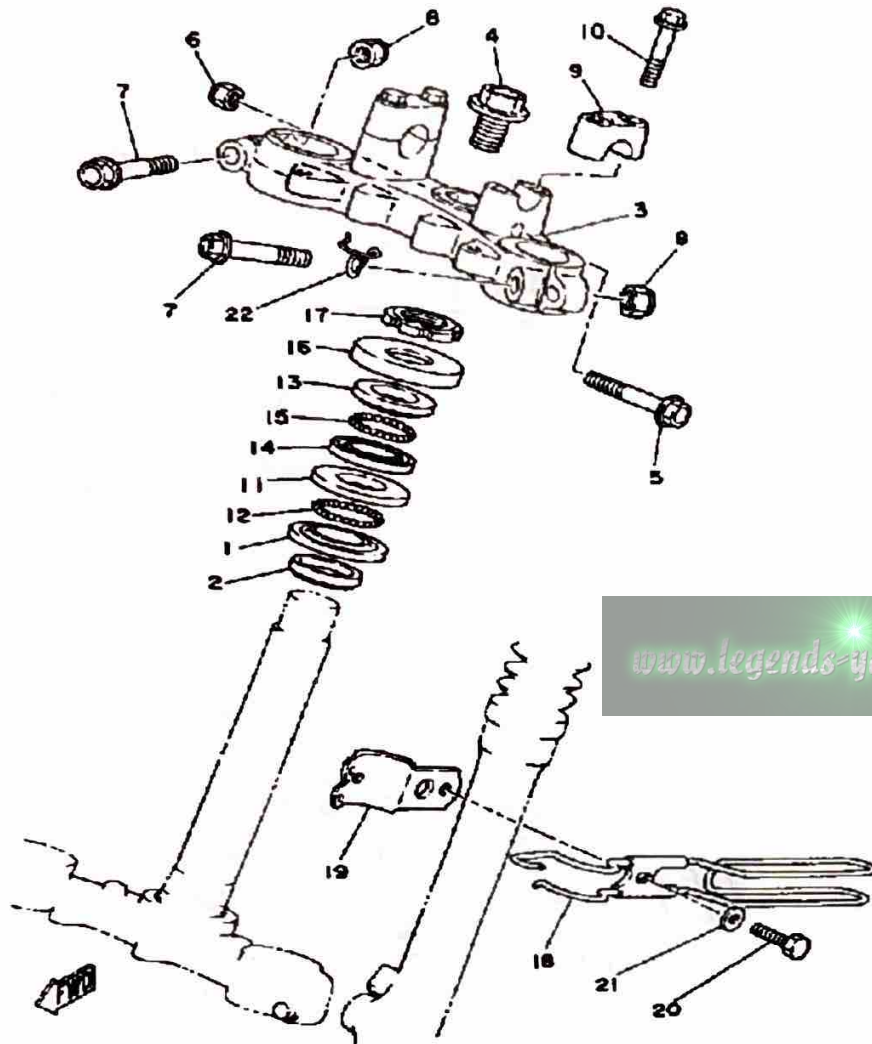

Ref. No.	Part Number	Description	Qty	Remarks
1	156-23411-00-00	RACE, BALL 1	1	
2	164-23462-00-00	SEAL, STEERING	1	
3	(3J0-23435-00-98)	CROWN, HANDLE	1	LOW GLOSS BLK
4	90105-14136-00	BOLT, WASHER BASED	1	
5	95811-08055-00	BOLT, FLANGE	1	
6	90185-08089-00	NUT, SELF-LOCKING	1	
7	95811-10060-00	BOLT, FLANGE	2	
8	90185-10060-00	NUT, SELF-LOCKING	2	
9	1E6-23441-00-00	HOLDER, HANDLE UPR	2	LOW GLOSS BLK
10	95811-08035-00	BOLT, FLANGE (95821-08035) .	4	
11	156-23412-00-00	RACE, BALL 2	1	
12	93501-04011-00	BALL	19	
13	22F-23411-01-00	RACE, BALL 1	1	
14	22F-23412-01-00	RACE, BALL 2	1	
15	93503-16010-00	BALL	22	
16	10V-23416-01-00	COVER, BALL RACE 2	1	
17	90179-25033-00	NUT	1	
18	2A6-23318-00-00	HOLDER, CABLE 1	1	
19	2A6-23319-00-00	HOLDER, CABLE 2	1	
20	97011-06025-00	BOLT (97001-06025)	2	
21	92901-06600-00	WASHER	1	
22	(4F2-23389-00-00)	GUIDE, CABLE	1	

FRONT FORK

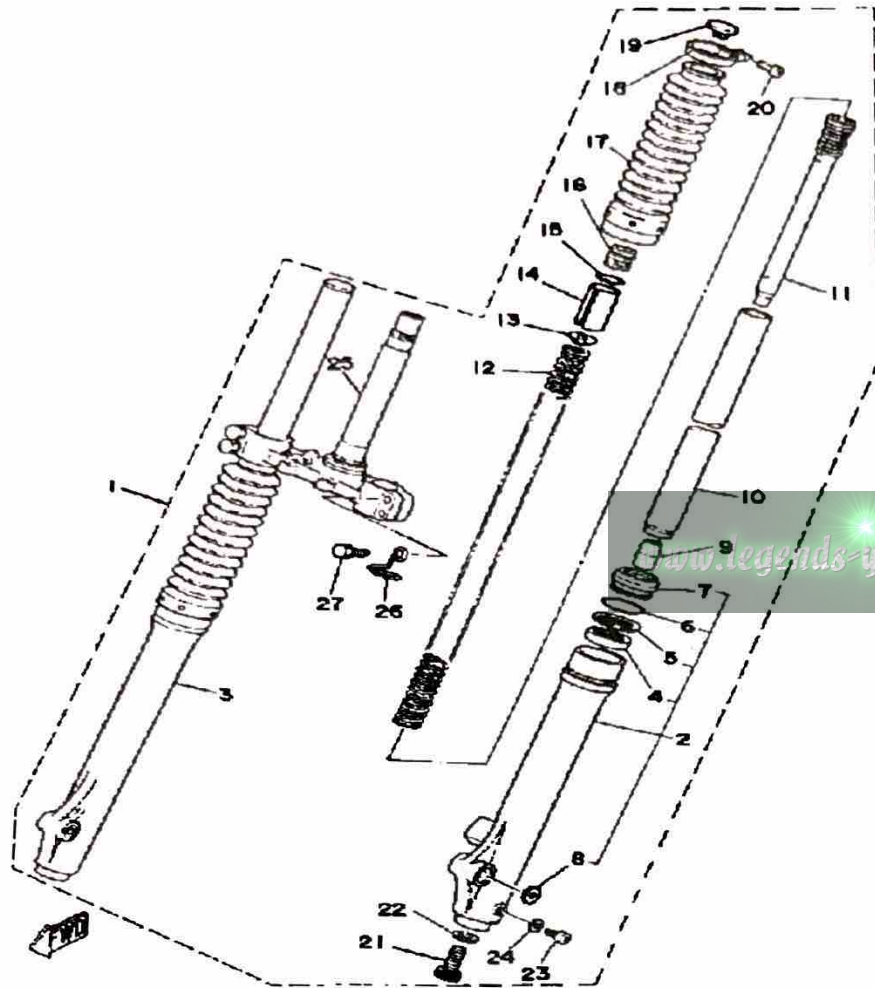

Ref. No.	Part Number	Description	Qty	Remarks
1	(3J1-23101-00-00)	FRONT FORK ASSEMBLY	1	
2	(2N4-23126-00-00)	TUBE, OUTER 1	1	
3	(2N4-23136-00-00)	TUBE, OUTER 2	1	
4	2K5-23145-00-00	. OIL SEAL	2	
5	2K5-23146-00-00	. WASHER, OIL SEAL	2	
6	15E-23153-00-00	. RING, SNAP	2	
7	3Y6-23144-00-00	. SEAL, DUST (2K5-23144-00)	2	
8	(2K5-23165-00-00)	WASHER, FELT	2	
9	2K5-23173-00-00	. SPINDLE, TAPER	2	
10	2N4-23110-00-00	. INNER TUBE 1	2	
11	(2K5-23170-00-00)	CYLINDER, FRTRFRK	2	
12	(2N4-23141-00-00)	SPRING, FRONT FORK	2	
13	256-23142-60-00	. SEAT, SPRING UPPER	2	
14	(256-23118-60-00)	SPACER	2	
15	146-23114-00-00	. GASKET	2	
16	1X0-23111-00-00	. BOLT, CAP	2	
17	2K5-23191-M0-00	. BOOT, FRONT FORK	2	
18	2K5-23192-00-00	. BAND	2	
19	1X0-23168-00-00	. CAP (2N4-23168-00)	2	
20	509-23194-L0-00	. SCREW, BOOT BAND	2	
21	278-23181-50-00	. BOLT, HEXAGON SOCKET HEAD	2	
22	509-23158-L0-00	. GASKET	2	
23	98580-04008-00	. SCREW, PAN HEAD	2	
24	122-23129-00-00	. GASKET, DRAIN PLUG	2	
25	(2N4-23340-00-33)	UNDER BRACKET	1	YAMAHA BLACK
26	(4F2-23317-00-00)	HOLDER, CABLE	1	
27	5X6-23181-L0-00	. BOLT, HEX SCKT HEADSOCKET HEAD	1	

FUEL TANK

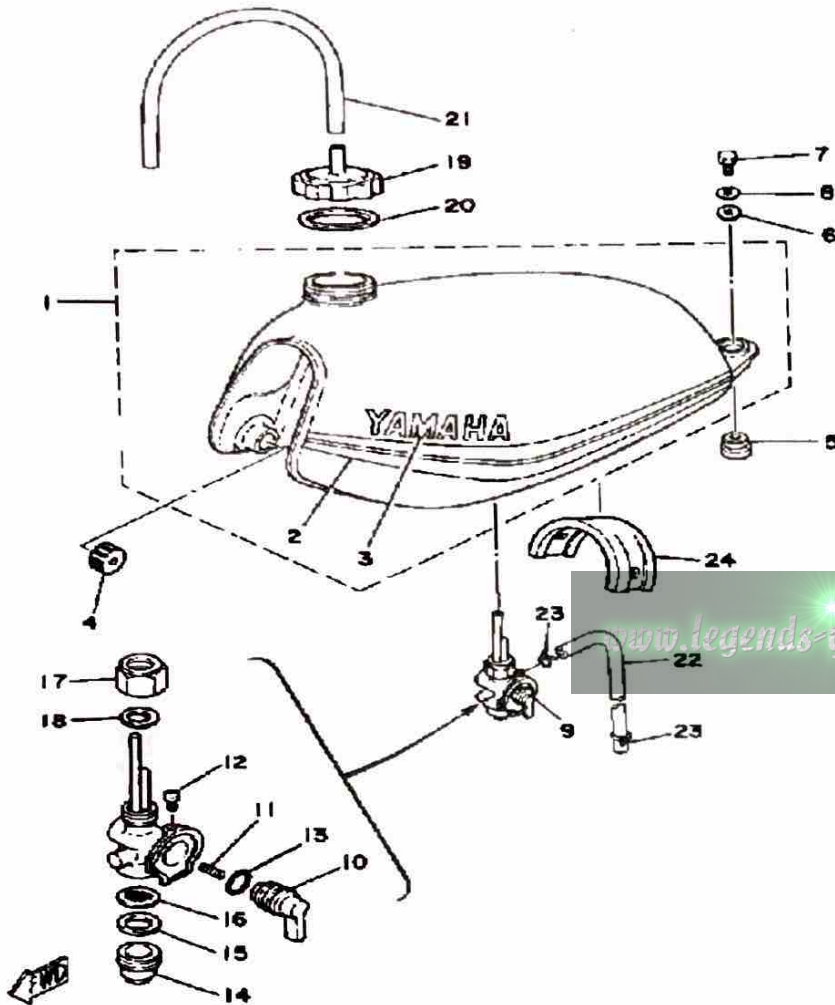

Ref. No.	Part Number	Description	Qty	Remarks
1	2N4-24110-Y0-03	FUEL TANK	1	CHAPPY RED
2	3J1-24240-20-00	. GRAPHIC SET	1	
3	388-24161-00-00	. EMBLEM 1	2	
4	278-24181-00-00	DAMPER, LOCATING 1	2	
5	90480-22231-00	GROMMET	2	
6	90201-06073-00	WASHER, PLATE	2	
7	97013-06012-00	BOLT	2	
8	92995-06100-00	WASHER, SPRING	2	
9	304-24500-12-00	FUEL COCK ASSEMBLY 1 ...	1	
10	(357-24524-10-00)	LEVER, COCK	1	
11	(357-24529-10-00)	SPRING	1	
12	2N3-24535-00-00	. SCREW, LVR FITTING	1	
13	2N3-24528-00-00	. GASKET	1	
14	(357-24521-10-00)	CUP, FILTER	1	
15	357-24522-10-00	. GASKET	1	
16	357-24515-10-00	. NET, FILTER 2	1	
17	2N3-24531-00-00	. NUT	1	
18	2N3-24532-00-00	. GASKET	1	
19	2A6-24611-00-00	BODY, CAP	1	
20	1W1-24612-00-00	GASKET, CAP	1	
21	90445-09115-00	HOSE	1	
22	90445-09089-00	HOSE	1	
23	90467-08003-00	CLIP	2	
24	2A6-24182-00-00	DAMPER, LOCATING 2	1	

SEAT

Ref. No.	Part Number	Description	Qty	Remarks
1	2N4-W2473-00-00	SEMI-DBL-SEAT ASSEMBLY (2N4-24770-90)	1	
2	2N4-24771-00-00	. COVER, SM-DBL SEAT	1	
3	509-24724-00-00	DAMPER, SEAT	4	
4	214-24724-00-00	DAMPER, SEAT	2	
5	1M1-24748-00-00	BRACKET, SEAT	1	
6	2A6-24738-00-00	BRACKET, SEAT	2	
7	97013-06012-00	BOLT	6	
8	92995-06100-00	WASHER, SPRING	6	
9	97313-08012-00	BOLT	2	
10	92901-08600-00	WASHER	2	
11	(2A6-24734-00-00)	BAND, SEAT	1	ALTERNATE PART
12	2A8-24736-00-00	WASHER	2	ALTERNATE PART
13	97313-08020-00	BOLT, HEXAGON	2	ALTERNATE PART
14	92990-08100-00	WASHER	2	ALTERNATE PART

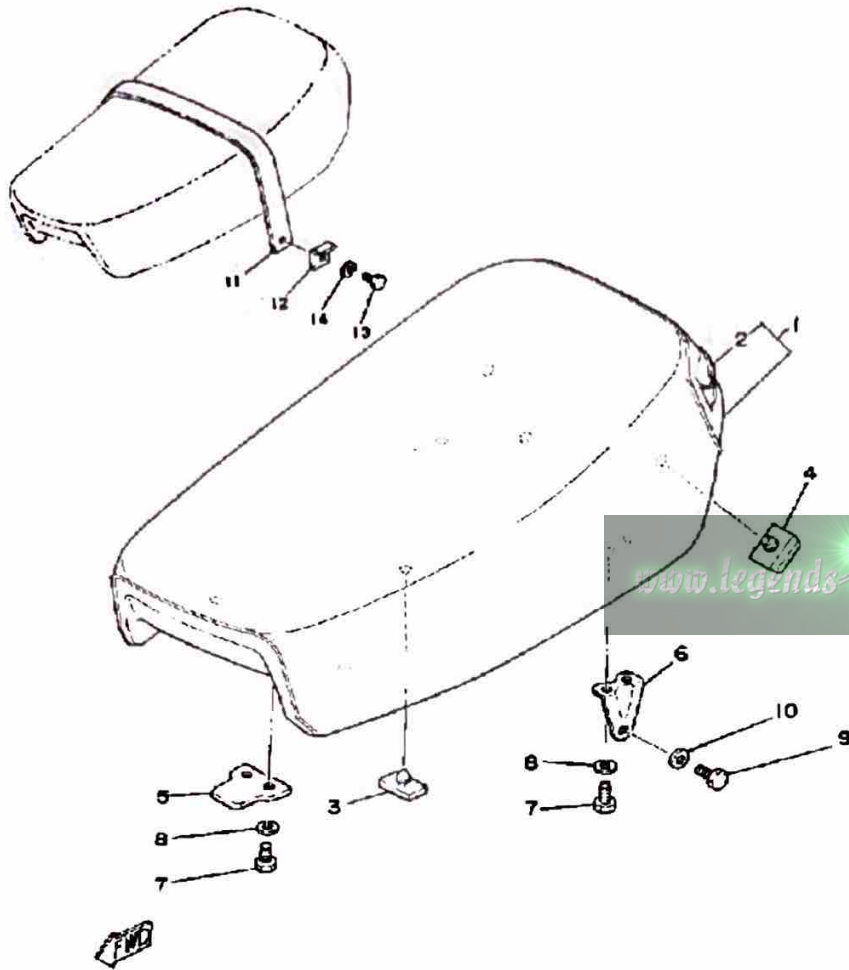

FRONT WHEEL

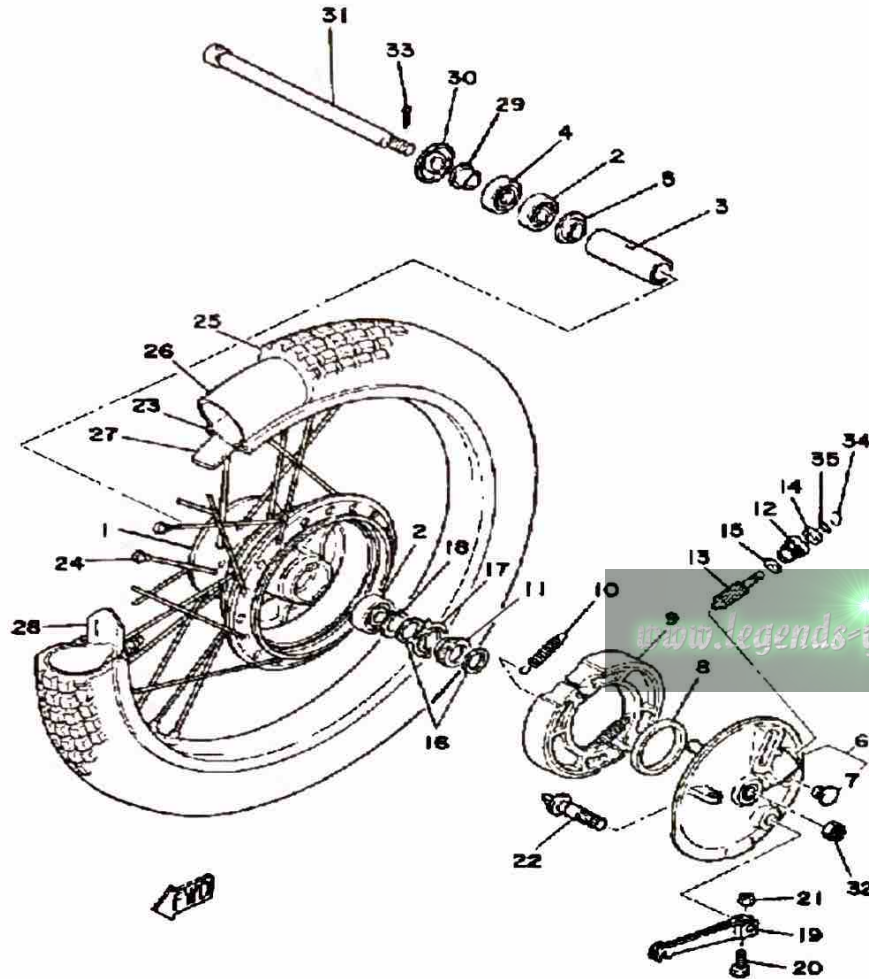

Ref. No.	Part Number	Description	Qty	Remarks
1	2A6-25111-00-98	HUB, FRONT	1	LOW GLOSS BLK
2	93306-30103-00	BEARING (B6301Z)	2	
3	90560-12261-00	SPACER	1	
4	93102-18008-00	OIL SEAL	1	
5	109-25315-00-00	FLANGE, SPACER	1	
6	2N4-25016-01-98	BRAKE SHOE PLT ASSEMBLY (2N4-25120-00-98)	1	LOW GLOSS BLK
7	90480-10068-00	GROMMET	1	
8	93105-47007-00	OIL SEAL	1	
9	437-W2536-00-00	BRAKESHOE SET-2PCS	2	
10	90506-17328-00	SPRING, TENSION	2	
11	248-25135-11-00	GEAR, DRIVE	1	
12	109-25136-00-00	BUSH	1	
13	(248-25138-11-00)	GEAR, METER	1	
14	93104-07003-00	OIL SEAL	1	
15	90201-07076-00	WASHER, PLATE	1	
16	90201-20269-00	WASHER, PLATE	2	
17	183-25149-00-00	CLUTCH, METER	1	
18	99009-20400-00	CIRCLIP	1	
19	5H0-25155-00-00	LEVER, CAMSHAFT 1	1	
20	90101-06278-00	BOLT	1	
21	95380-06600-00	NUT	1	
22	2RH-25351-00-00	CAMSHAFT	1	
23	94416-21206-00	RIM 1.60X21 (1.60-21) (94416-21312, B, +", F,)	1	
24	2A6-25104-00-00	SPOKE SET, FRONT	1	
25	94127-212X0-00	TIRE (2.75-21)	1	
26	94227-21123-00	TUBE (2.75-21)	1	
27	94330-21084-00	BAND, RIM (3.00-21)	1	

CONTINUED ON NEXT FRAME ►

FRONT WHEEL

Ref. No.	Part Number	Description	Qty	Remarks
28	1T1-25194-00-00	SPACER, BEAD	1	
29	90387-12265-00	COLLAR (183-25183-00)	1	
30	2K5-25118-00-00	COVER, HUB DUST	1	
31	353-25381-00-00	AXLE, WHEEL	1	
32	90171-10004-00	NUT, CASTLE	1	
33	91490-20020-00	PIN, COTTER	1	
34	102-25137-00-00	RING, STOP	1	
35	93210-14104-00	O-RING	1	

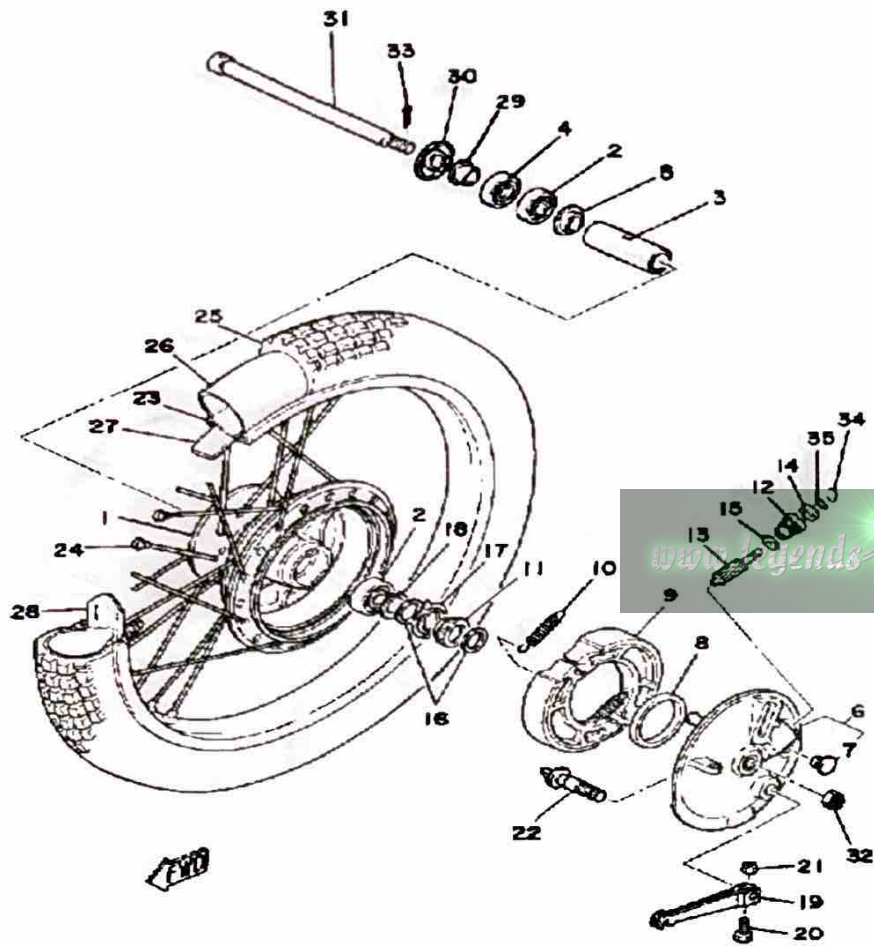

REAR WHEEL

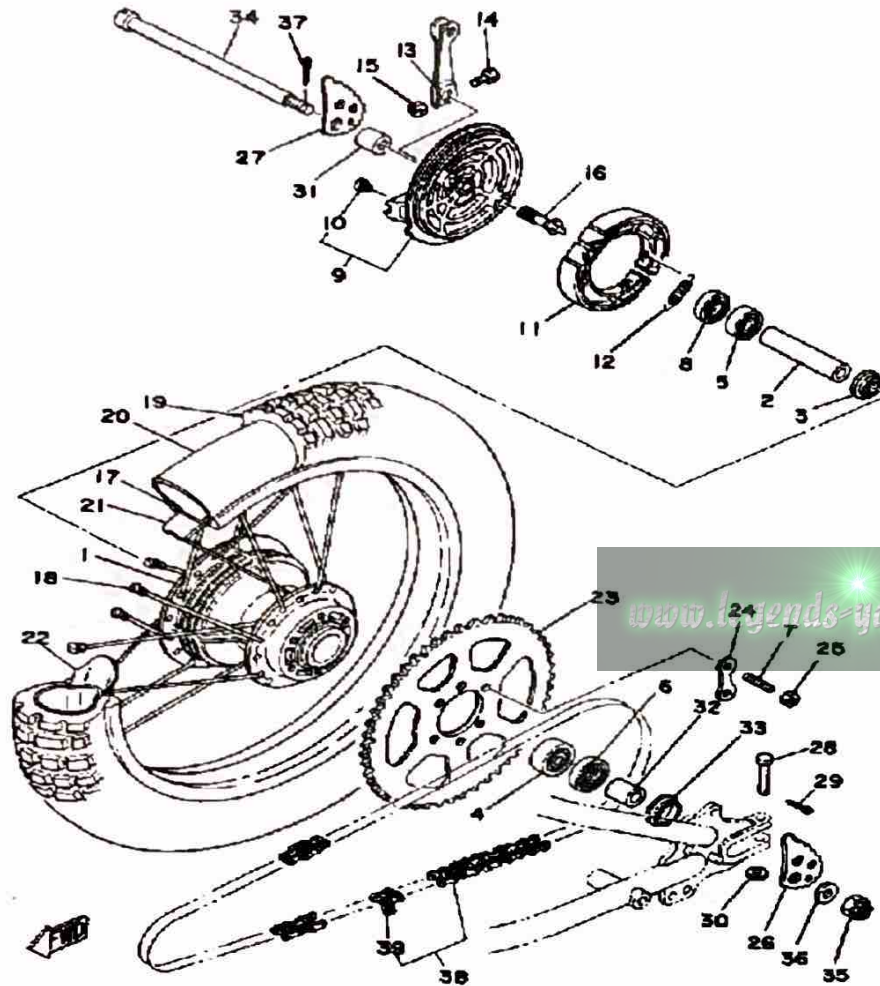

Ref. No.	Part Number	Description	Qty	Remarks
1	1W1-25311-00-98	HUB, REAR	1	LOW GLOSS BLK
2	90560-15313-00	SPACER	1	
3	146-25115-00-00	FLANGE, SPACER 1	1	
4	93306-30202-00	BEARING	1	
5	93306-20204-00	BEARING (B6202Z)	1	
6	93106-26005-00	OIL SEAL	1	
7	90116-10221-00	BOLT, STUD	6	
8	93104-22018-00	OIL SEAL	1	
9	99999-02024-00	BRAKE SHOE PLT ASSEMBLY (2A6-25026-00-98)BRAKE SHOE PLAT	1	LOW GLOSS BLK
10	90480-10068-00	. GROMMET	1	
11	437-W2536-00-00	BRAKESHOE SET-2PCS	2	
12	90506-17328-00	SPRING, TENSION	2	
13	1E2-25155-00-00	LEVER, CAMSHAFT 1	1	
14	90101-06278-00	BOLT	1	
15	95380-06600-00	NUT	1	
16	2RH-25351-00-00	CAMSHAFT	1	
17	94418-18171-00	RIM 1.85X 8	1	
18	401-25304-20-00	COMPLETE REAR WHEEL SPOKE SET	1	
19	(94135-18378-00)	BS 350X18 T 5	1	
20	94230-18084-00	TUBE	1	
21	94345-18081-00	BAND, RIM (4.50-18)	1	
22	1T2-25394-00-00	SPACER, BEAD	1	
23	18L-25449-20-00	SPROCKET, DRVN 49T	1	YAMAHA BLACK
24	1G8-25412-00-00	WASHER	3	
25	95701-10500-00	NUT, FLANGE (95702-10500)	6	
26	1W2-25388-01-00	PULLER, CHAIN 1	1	
27	1W2-25389-01-00	PULLER, CHAIN 2	1	

CONTINUED ON NEXT FRAME ►

REAR WHEEL

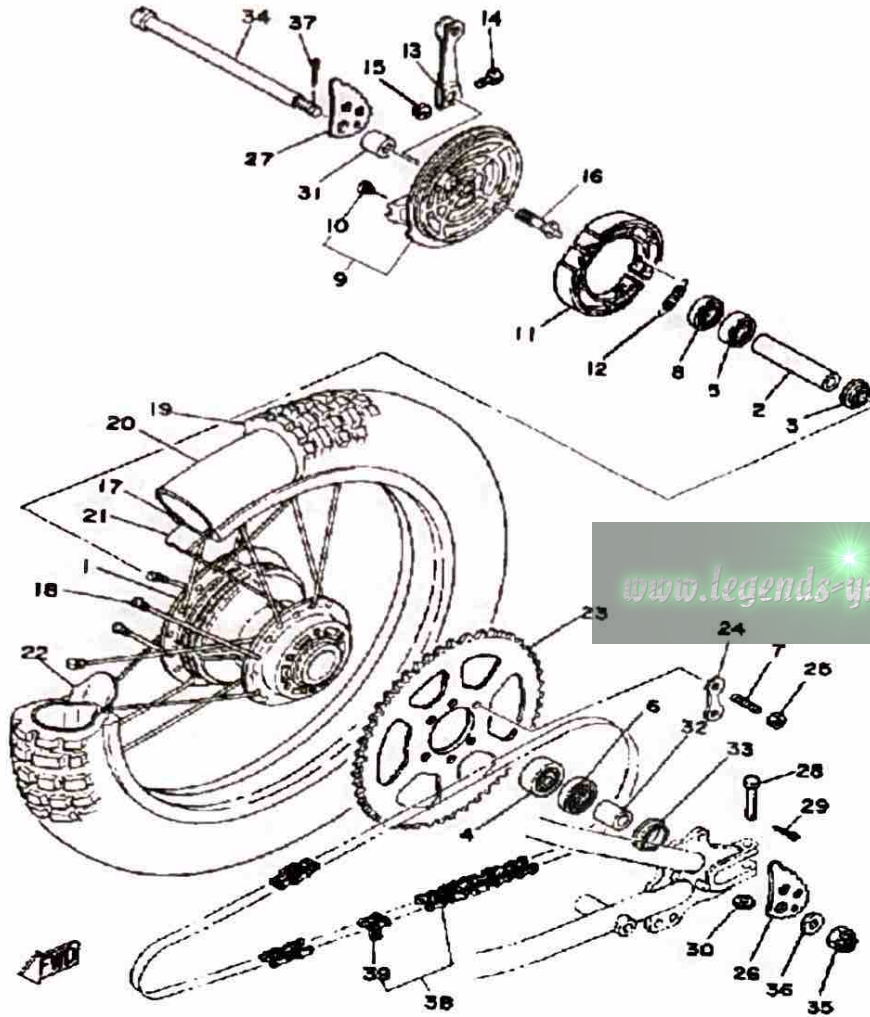

Ref. No.	Part Number	Description	Qty	Remarks
28	91701-06042-00	PIN, CLEVIS	2	
29	91490-20020-00	PIN, COTTER	2	
30	92901-06600-00	WASHER	2	
31	90387-15524-00	COLLAR	1	
32	90387-15524-00	COLLAR	1	
33	401-25367-00-00	COVER, HUB DUST	1	
34	5X3-25381-00-00	AXLE, WHEEL (2A6-25381-00-00)	1	
35	90171-14020-00	NUT, CASTLE	1	
36	90201-15238-00	WASHER, PLATE	1	
37	91401-30030-00	PIN, COTTER	1	
38	94580-33118-00	DID428DS-118L (94580-15118) .	1	
39	94680-15001-00	. JOINT CHAIN	1	

HANDLEBAR - CABLE

Ref. No.	Part Number	Description	Qty	Remarks
1	3G7-26111-00-00	HANDLEBAR	1	
2	1Y1-26290-10-00	MIRROR ASSEMBLY LH	1	
3	90338-09012-00	PLUG	1	
4	434-26243-00-00	TUBE, THROTTLE GUIDE	1	
5	1A0-26242-01-00	GRIP (RIGHT)	1	
6	1M1-26249-01-00	RING, LEAF	1	
7	1E6-26241-00-00	GRIP LH	1	
8	3J0-26311-01-00	CABLE, THROTTLE 1	1	
9	3J1-26312-00-00	CABLE, THROTTLE 2	1	
10	3J1-26321-00-00	CABLE, PUMP	1	
11	3J0-26261-00-00	CONNECTOR, CABLE	1	
12	3J0-26262-00-00	CAP, CBLE CONNECTOR	1	
13	360-26266-00-00	BOOT, CYLINDER	1	
14	3J0-26272-00-00	CAP	1	
15	2T5-26274-00-00	GUIDE, ROTOR	1	
16	2T5-26273-00-00	ROTOR	1	
17	2T5-26244-00-00	SLIDER, THROTTLE	1	
18	2T5-26267-00-00	PIN	1	
19	90167-03004-00	SCREW, TAPPING	4	
20	90501-05512-00	SPRING, COMPRESSION	1	
21	3J0-26393-00-00	HOLDER	1	
22	90170-10038-00	NUT, HEXAGON	1	
23	2A6-26335-01-00	CABLE, CLUTCH	1	
24	382-26372-01-00	. COVER, HANDLE LEVER ...	1	
25	2N4-26341-01-00	CABLE, BRAKE (1165MM)	1	
26	498-26372-00-00	. COVER, HANDLE LEVER 1 ..	1	
27	90123-08046-00	BOLT	2	
28	90179-08148-00	NUT	2	
29	2A6-26397-00-00	CLAMP	1	

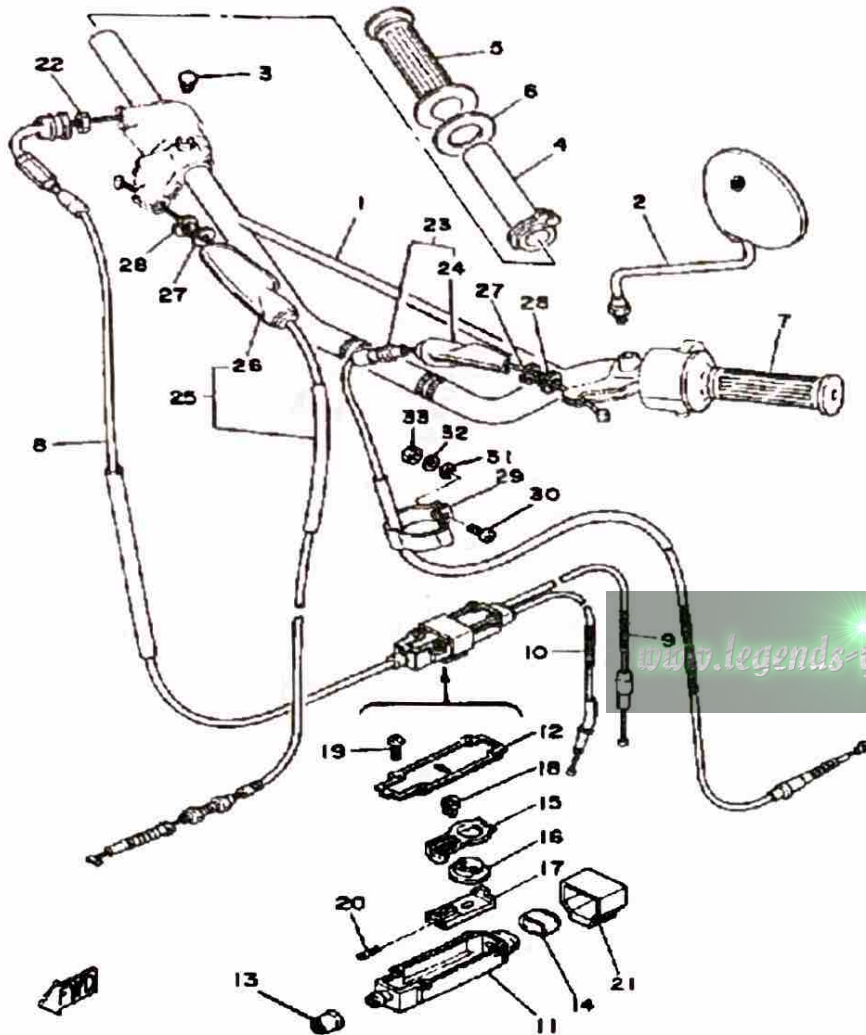

CONTINUED ON NEXT FRAME ►

HANDLEBAR - CABLE

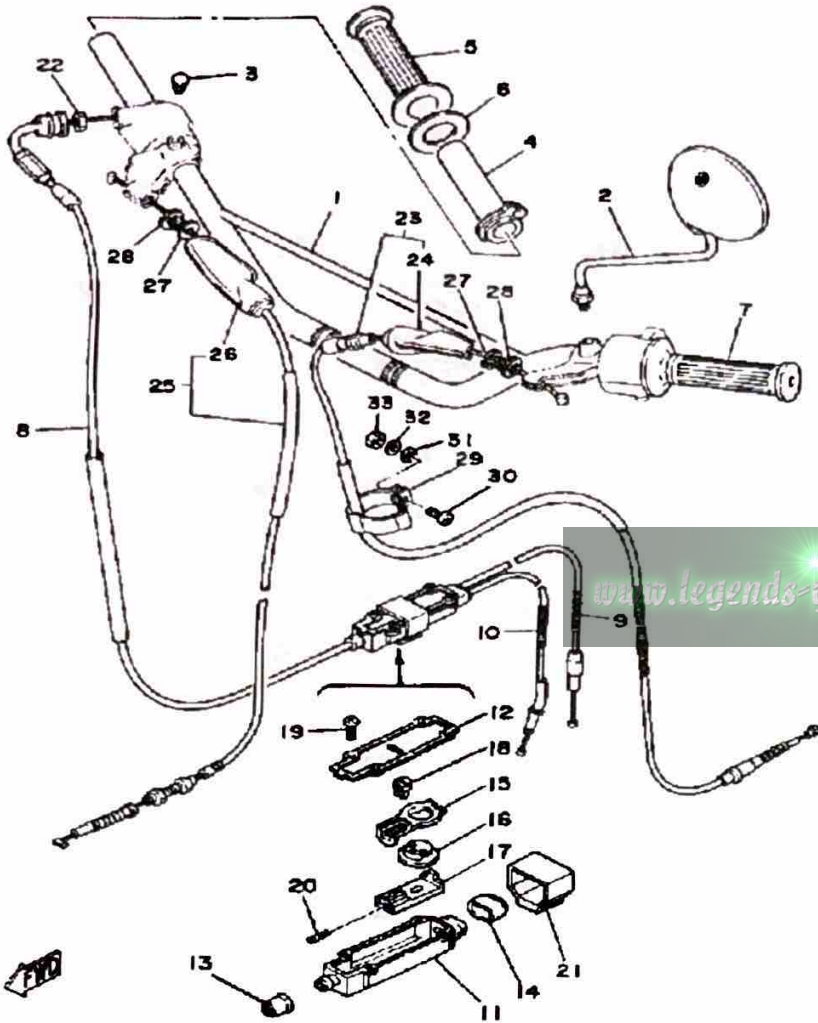

Ref. No.	Part Number	Description	Qty	Remarks
30	98501-05018-00	SCREW, PAN HEAD	1	
31	92901-05600-00	WASHER, PLATE	1	
32	92901-05600-00	WASHER, PLATE	1	
33	95380-05600-00	NUT	1	
34	1Y1-26290-00-00	MIRROR ASSEMBLY RH	1	ALTERNATE PART

STAND - FOOTREST

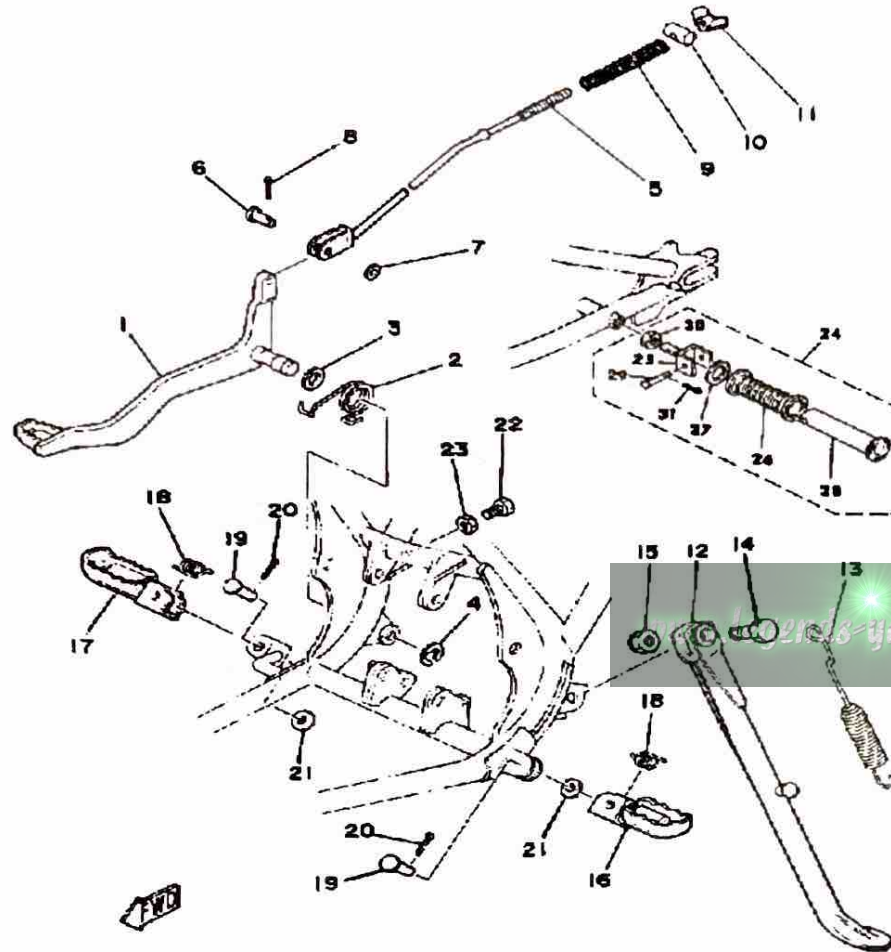

Ref. No.	Part Number	Description	Qty	Remarks
1	2A6-27211-00-00	PEDAL, BRAKE	1	UNI CHROME (BLK)
2	90508-32354-00	SPRING, TORSION	1	
3	90201-14212-00	WASHER, PLATE	1	
4	93403-10015-00	UNAVAILABLE IN PRICE BOOK	1	
5	1W2-27231-00-00	ROD, BRAKE	1	
6	90240-06006-00	PIN, CLEVIS	1	
7	92990-06200-00	WASHER	1	
8	91401-25020-00	PIN, COTTER	1	
9	90501-10245-00	SPRING, COMPRESSION	1	
10	90249-12008-00	PIN	1	
11	90179-06411-00	NUT	1	
12	1W1-27311-10-00	STAND, SIDE	1	
13	90507-29008-00	SPRING, TENSION	1	
14	90109-103A1-00	BOLT	1	
15	90185-10037-00	NUT, SELF-LOCKING	1	
16	22W-27411-01-90	FOOTREST 1	1	UNI CHROME (BLK)
17	22W-27421-01-90	FOOTREST 2	1	UNI CHROME (BLK)
18	90508-20023-00	SPRING, TORSION	2	
19	91701-08038-00	PIN, CLEVIS	2	
20	91401-25020-00	PIN, COTTER	2	
21	92901-08600-00	WASHER	2	
22	97011-06020-00	BOLT	1	
23	95380-06700-00	NUT	1	
24	120-27430-02-00	RR FOOTREST ASSEMBLY 1	2	ALTERNATE PART
25	120-27432-02-00	. BRACKET 1	1	ALTERNATE PART
26	120-27433-00-00	. COVER, REAR FOOTREST ..	1	ALTERNATE PART
27	90201-20279-00	. WASHER, PLATE	1	ALTERNATE PART
28	120-27431-00-00	. FOOTREST, REAR 1	1	ALTERNATE PART
29	90240-06009-00	. PIN, CLEVIS	1	ALTERNATE PART

CONTINUED ON NEXT FRAME ►

STAND - FOOTREST

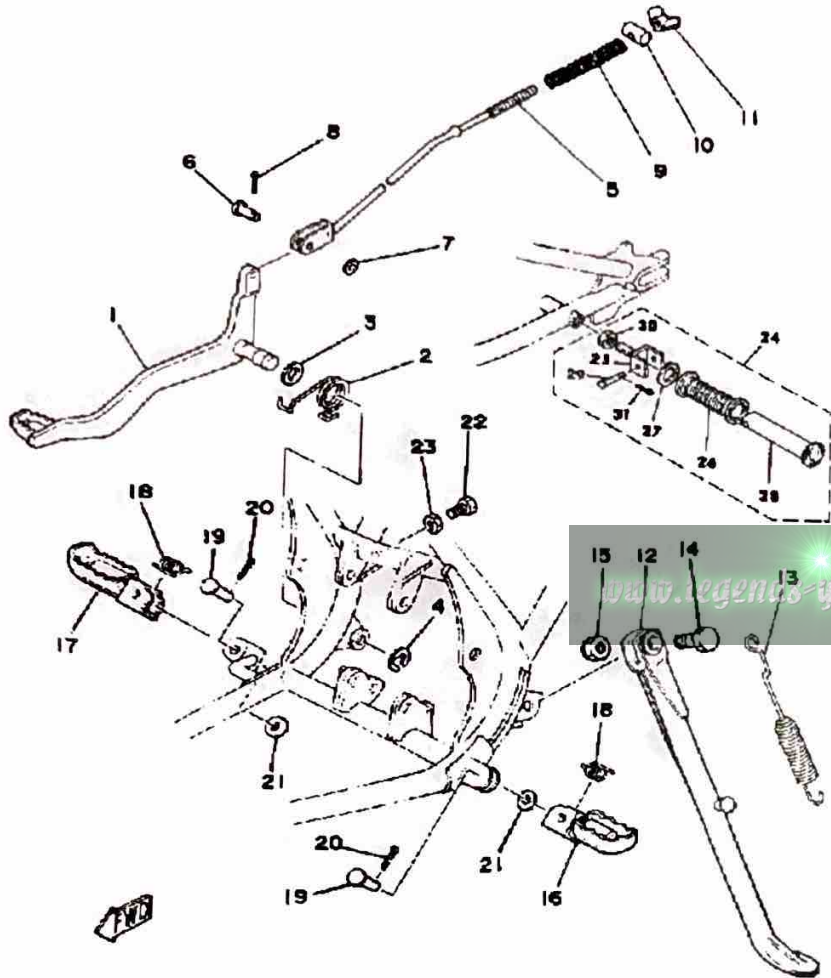

Ref. No.	Part Number	Description	Qty	Remarks
30	95301-12700-00	. NUT (95302-12700)	1	ALTERNATE PART
31	91490-16020-00	. PIN, COTTER	1	ALTERNATE PART

FLASHER LIGHT

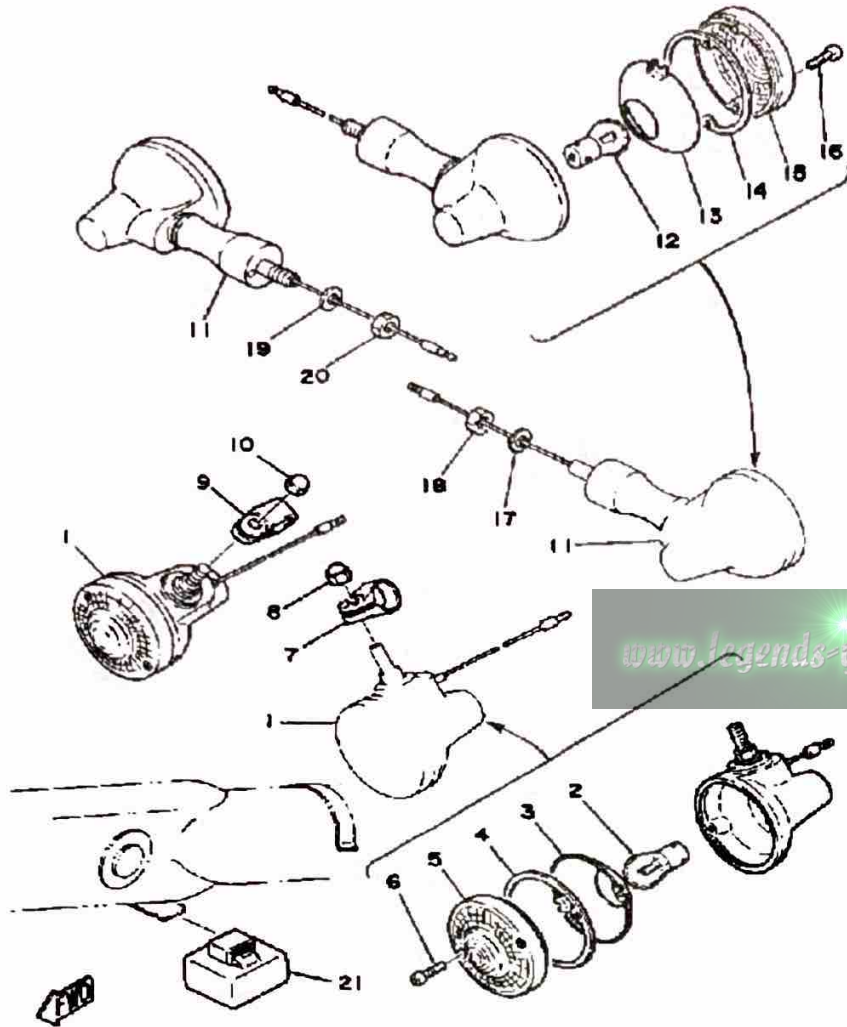

Ref. No.	Part Number	Description	Qty	Remarks
1	1M1-83310-60-00	FRT FLSHR LITE ASSEMBLY ASS'Y 1	2	
2	115-83311-60-00	. BULB, FLASHER	1	
3	1M1-83309-60-00	. REFLECTOR	1	
4	1M1-83313-60-00	. GASKET, FLSHR LENS	1	
5	341-83312-70-00	. LENS, FLASHER	1	
6	97780-30120-00	. SCREW, PANHEAD TAP	2	
7	1M1-83318-00-00	STAY, FLASHER 1	1	
8	95303-08800-00	NUT (CROWN) (95301-08800)	1	
9	1M1-83318-00-00	STAY, FLASHER 1	1	
10	95303-08800-00	NUT (CROWN) (95301-08800)	1	
11	1T9-83330-60-00	R FLSHR LITE ASSEMBLY	2	
12	115-83311-60-00	. BULB, FLASHER	1	
13	1M1-83309-60-00	. REFLECTOR	1	
14	1M1-83313-60-00	. GASKET, FLSHR LENS	1	
15	341-83312-70-00	. LENS, FLASHER	1	
16	97780-30120-00	. SCREW, PANHEAD TAP	2	
17	92990-10100-00	WASHER, SPRING	1	
18	95303-10600-00	NUT (95301-10600)	1	
19	92990-10100-00	WASHER, SPRING	1	
20	95303-10600-00	NUT (95301-10600)	1	
21	3BK-83350-00-00	FLASHER RELAY ASSEMBLY	1	

SPEEDOMETER

Ref. No.	Part Number	Description	Qty	Remarks
1	2N4-83570-A0-00	SPEEDOMETER ASSEMBLY ..	1	
2	122-83516-10-00	. BULB (122-83516-10)	1	
3	(1V1-83536-00-00)	SOCKET, METER	1	
4	1E6-83578-10-00	. KNOB, TRIP METER	1	
5	2A6-83506-00-00	RING, METER COVER	1	
6	2A6-83513-00-00	DAMPER	1	
7	1M1-83526-00-00	DAMPER 2	2	
8	90201-05033-00	WASHER, PLATE	2	
9	90468-10050-00	CLIP	2	
10	2X1-83540-F0-00	TACHOMETER ASSEMBLY (2N4-83540-00)	1	
11	122-83516-10-00	. BULB (122-83516-10)	5	
12	(2A6-83520-00-00)	SOCKET CORD ASSEMBLY ..	1	
13	2A6-83506-00-00	RING, METER COVER	1	
14	2A6-83513-00-00	DAMPER	1	
15	1M1-83526-00-00	DAMPER 2	2	
16	90201-05033-00	WASHER, PLATE	2	
17	90468-10050-00	CLIP	2	
18	3J0-83519-00-00	BRACKET, METER	1	
19	90385-06001-00	. BUSH, SPEC'L RUBBER (214-83528-00)	2	
20	97026-06045-00	BOLT	2	
21	92906-06600-00	WASHER	2	
22	92901-06600-00	WASHER	2	
23	92995-06100-00	WASHER, SPRING	2	
24	95380-06600-00	NUT	2	
25	1M1-83550-01-00	SPEEDOMETER CABLE (3H6-83550-00)	1	
26	2A6-83560-00-00	TACHOMETER CABLE	1	
27	(2A6-83595-00-00)	CLAMP	1	

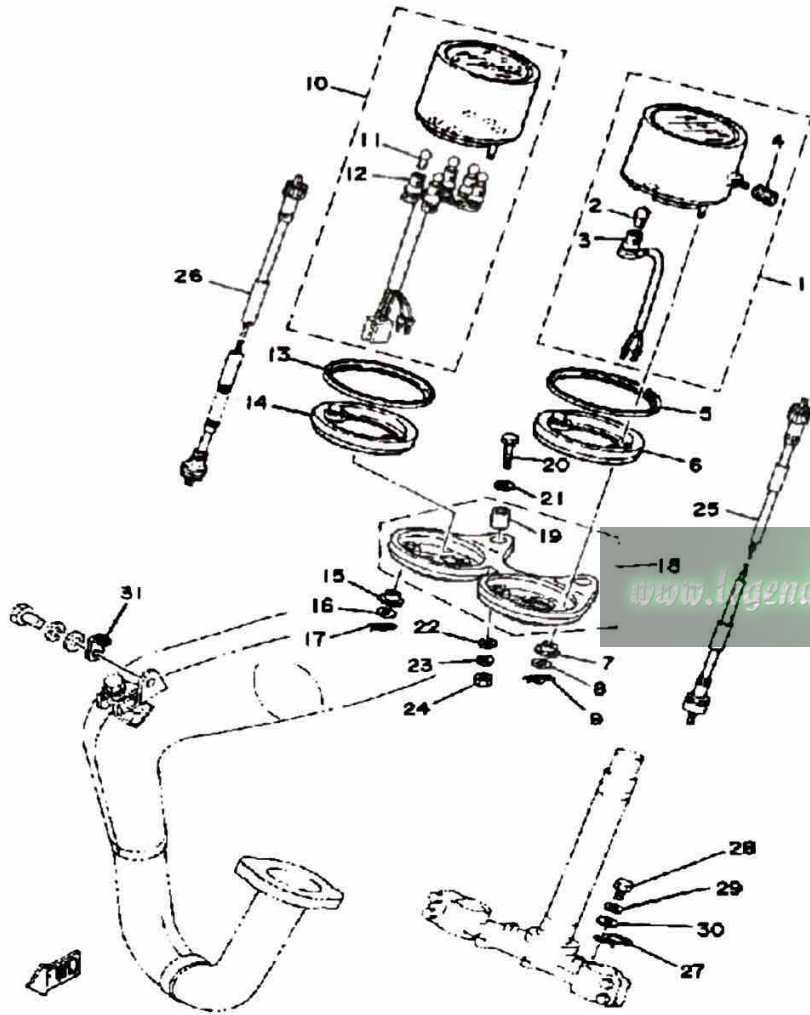

CONTINUED ON NEXT FRAME ►

SPEEDOMETER

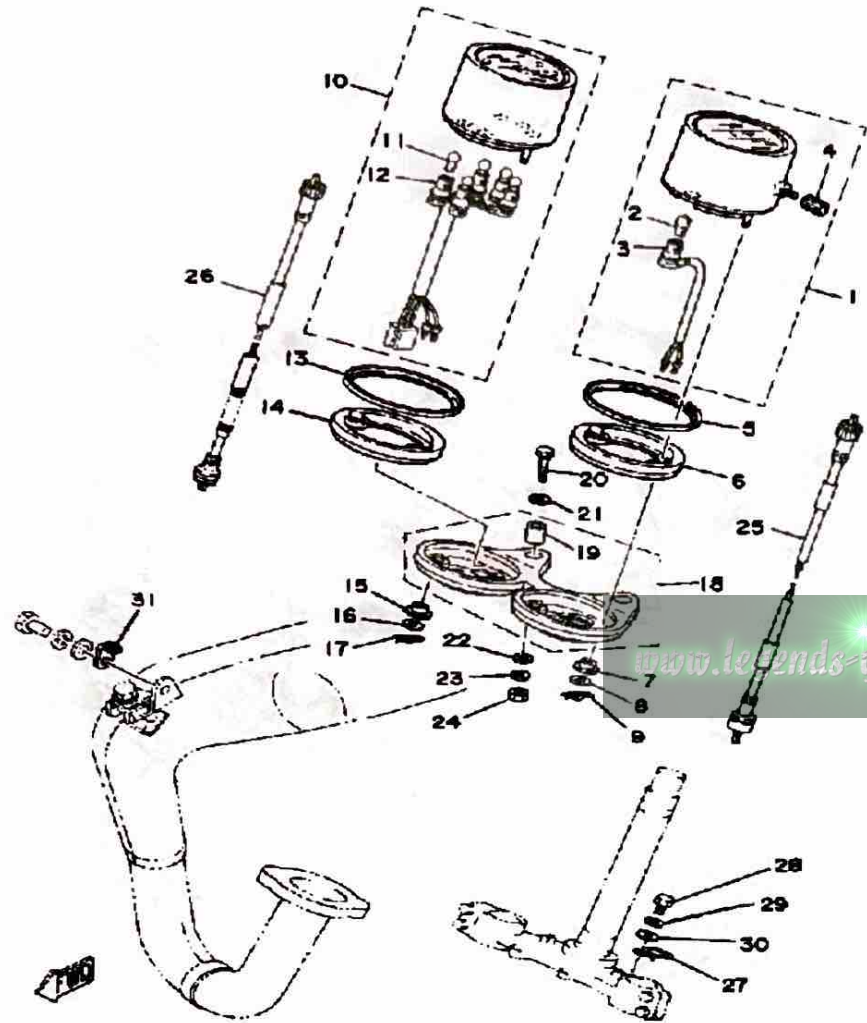

Ref. No.	Part Number	Description	Qty	Remarks
28	97013-06012-00	BOLT	1	
29	92995-06100-00	WASHER, SPRING	1	
30	92901-06600-00	WASHER	1	
31	2A6-83596-00-00	CLAMP	1	

www.legends-yamaha-enduros.com

HEADLIGHT

Ref. No.	Part Number	Description	Qty	Remarks
1	(3J0-84110-60-00)	HEADLIGHT UNIT ASSEMBLY	1	N/A
2	3J0-84195-60-00	. RING, RETAINING	1	
3	2A6-84120-60-00	. LENS ASSEMBLY	1	
4	341-84397-61-00	. COVER, SOCKET	1	
5	371-84312-60-00	. SOCKET	1	
6	1M1-84124-60-00	. SPRING, SET	3	
7	1M1-84133-60-00	. COLLAR, SCREW	1	
8	498-84128-60-00	. SPACER	1	
9	3J0-84130-60-00	BODY ASSEMBLY, HEADLIGHT	1	BLACK
10	498-84145-60-00	. COLLAR, BODY FITTING	2	
11	498-84163-60-00	. DAMPER	2	
12	1M1-84164-60-00	. DAMPER	2	
13	1M1-84137-60-00	BOLT, SPECIAL	1	
14	3Y1-84118-01-00	STAY, HEADLIGHT 1	1	
15	3Y1-84119-01-00	STAY, HEADLIGHT 2	1	
16	98506-06016-00	SCREW, PANHEAD	2	
17	92906-06100-00	WASHER, SPRING	2	
18	92906-06600-00	WASHER	2	
19	97313-08040-00	BOLT, HEXAGON (97322-08040)	2	
20	92990-08200-00	WASHER, PLAIN	4	
21	92990-08100-00	WASHER	2	
22	95333-08600-00	NUT	2	
23	355-85111-01-00	REFLECTOR, FRONT 1	2	
24	90430-06012-00	GASKET	2	

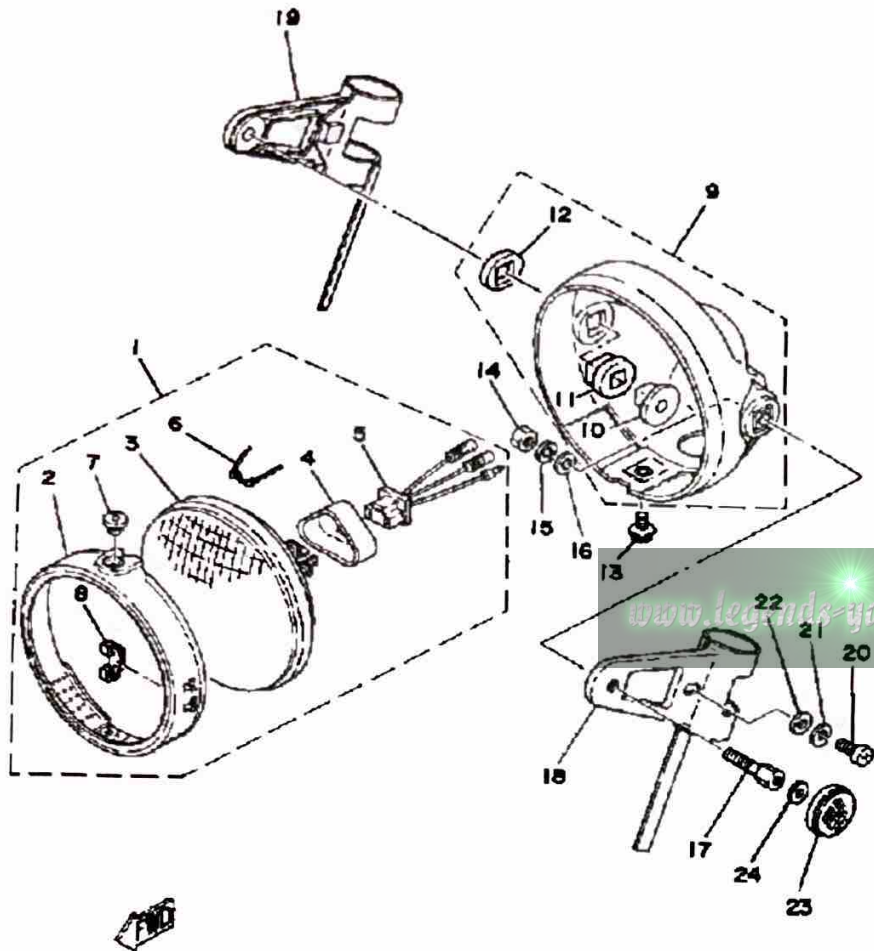

TAILLIGHT

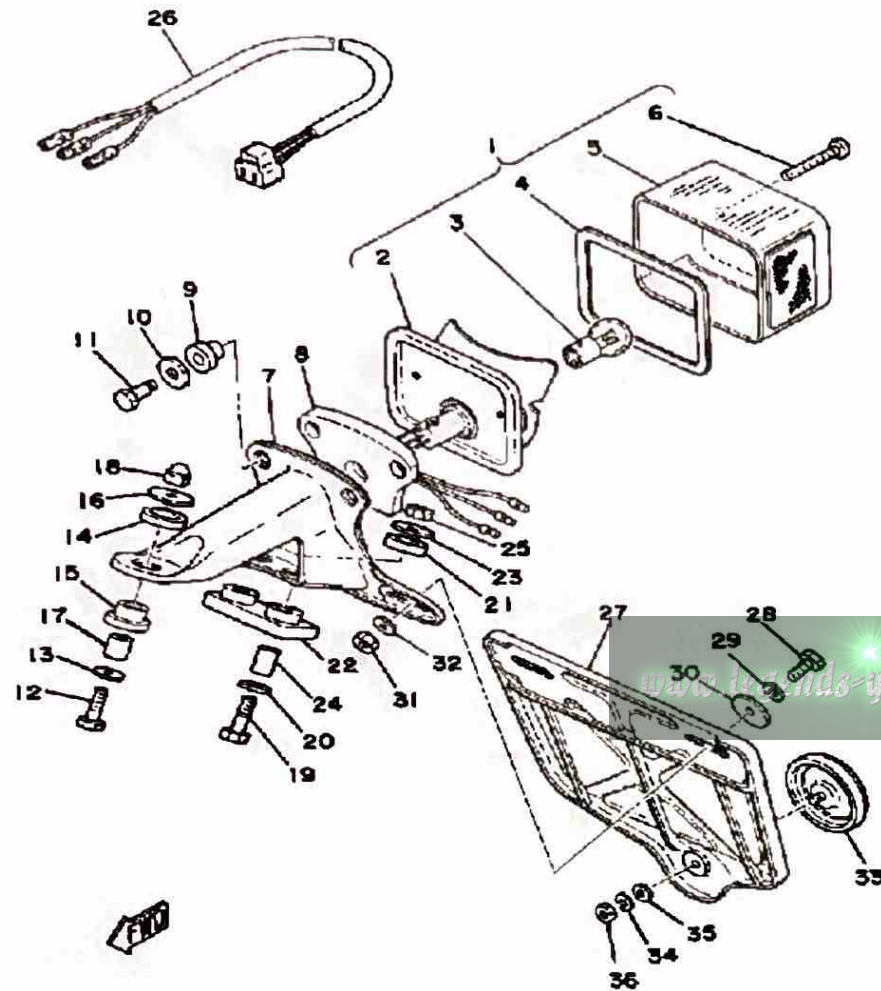

Ref. No.	Part Number	Description	Qty	Remarks
1	1M1-84510-60-00	TAILLIGHT UNIT ASSEMBLY ..	1	
2	1M1-84511-60-00	. BASE, TAILLIGHT	1	
3	1M1-84514-60-00	. BULB	1	
4	1M1-84523-60-00	. GASKET, LENS	1	
5	1M1-84521-60-00	. LENS, TAILLIGHT	1	
6	1M1-84524-60-00	. SCREW, LENS FITTING	2	
7	2A6-84551-60-33	BRACKET, LICENCE	1	YAMAHA BLACK
8	1M1-84512-60-00	SEAT, BASE	1	
9	1M1-84527-60-00	DAMPER	2	
10	2H7-84754-00-00	WASHER, SPECIAL	2	
11	1M1-84526-60-00	SCREW	2	
12	97011-06025-00	BOLT (97001-06025)	1	
13	92901-06600-00	WASHER	1	
14	1M1-84553-10-00	DAMPER	1	
15	1M1-84553-20-00	DAMPER	1	
16	90201-06074-00	WASHER, PLATE	1	
17	90387-06553-00	COLLAR	1	
18	95303-06800-00	NUT (CROWN)	1	
19	97013-06035-00	BOLT	2	
20	90201-06067-00	WASHER, PLATE	2	
21	1M1-84553-10-00	DAMPER	2	
22	1M1-84553-00-00	DAMPER	1	
23	90201-06074-00	WASHER, PLATE	2	
24	90387-06554-00	COLLAR	2	
25	95380-06600-00	NUT	2	
26	1M1-84517-00-00	CORD, TAILLIGHT	1	
27	1M1-85132-62-00	BRACKET, REFLECT 1	1	
28	97313-06016-00	BOLT, HEXAGON	2	
29	92995-06100-00	WASHER, SPRING	2	

CONTINUED ON NEXT FRAME ►

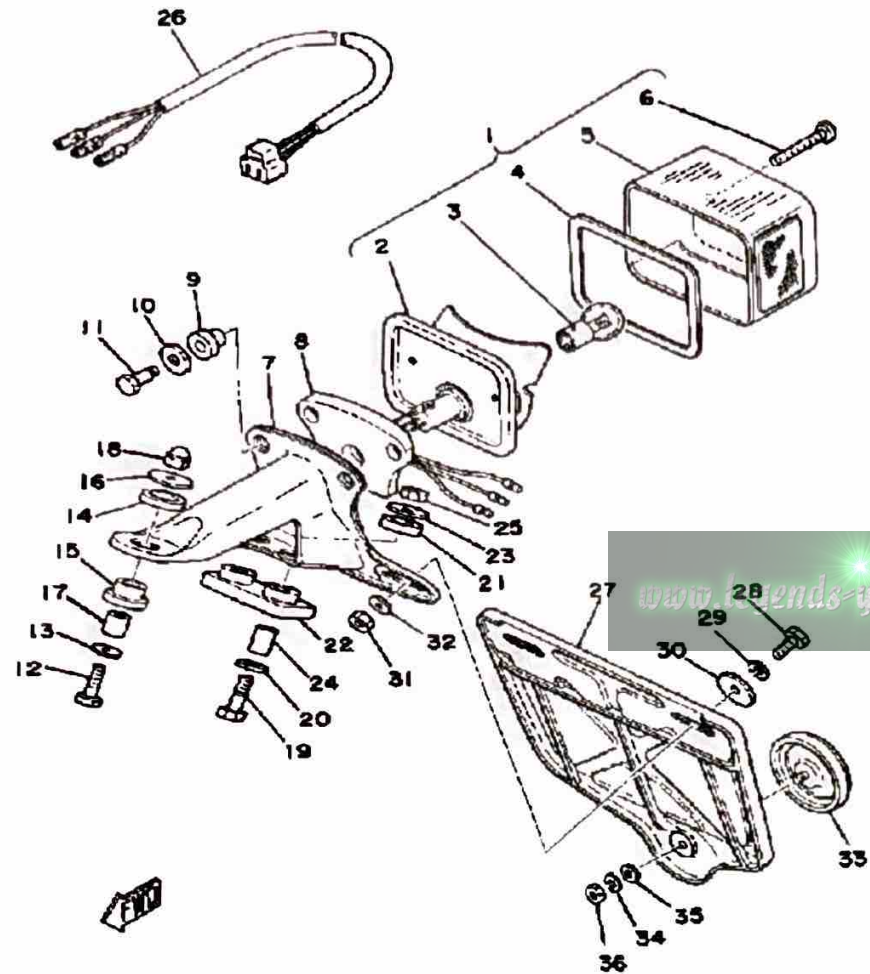

TAILLIGHT

Ref. No.	Part Number	Description	Qty	Remarks
30	90201-06074-00	WASHER, PLATE	2	
31	95380-06600-00	NUT	2	
32	92901-06600-00	WASHER	2	
33	1M1-85131-10-00	REFLECTOR, REAR 1	1	U.R.
	449-85131-02-00	REFLECTOR, REAR 1	1	U.R.
34	92990-05100-00	WASHER, SPRING	1	
35	92990-05200-00	WASHER, PLAIN	1	
36	95380-05600-00	NUT	1	

ELECTRICAL 1

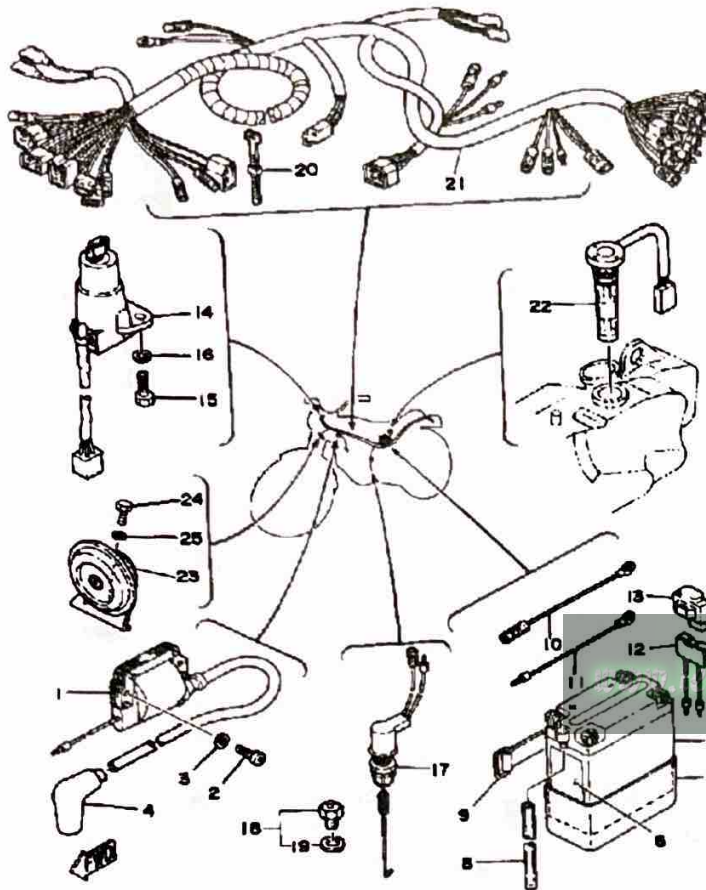

Ignition Coil Test Gap / Primary Ω / Secondary Ω	6mm / 1.0 Ω \pm 10% / 5.8K Ω \pm 20%
Pulse Coil or Pickup Coil Color Code / Ω	Wht-Red ~ Blk / 10 Ω \pm 10%
Source Coil Color Code / Ω	Bm ~ Blk / 300 Ω \pm 10%
LIGHTING SYSTEM	
Headlight / Taillight / Signal Rating	6V/35-35W / 6V/25-5.3W / 6V/17W
Battery: Model / Specific Gravity / Charge Rate	GS 6N6-3B-1 (6V 6AH) / 1.26 / 0.6A
Maximum Output	8.7V 2.5A @ 8000 rpm

Ref. No.	Part Number	Description	Qty	Remarks
1	5G4-82310-40-00	IGNITION COIL ASSEMBLY (J17-82310-21)	1	
2	98580-06020-00	SCREW	2	
3	92995-06100-00	WASHER, SPRING	2	
4	81E-82370-20-00	PLUG CAP ASSEMBLY	1	
	8E7-82370-11-00	PLUG CAP ASSEMBLY	1	ALTERNATE PART
5	BTY-6N63B-10-00	YUASA 6N6-3B-1 (1E6-82110-29)	1	
6	118-82141-09-00	LABEL, BATTERY	1	
7	(3J0-82122-00-00)	SEAT, BATTERY	1	
8	(90445-08357-00)	HOSE	1	
9	120-82131-00-00	BAND, BATTERY	1	
10	J42-82318-00-00	WIRE, SUB-LEAD	1	
11	1H2-83346-00-00	CORD (1M1-82519-00)	1	
12	3J0-82180-00-00	CIRCUIT BREAKER (3J0-82181-00)	1	
13	3J0-82182-00-00	COVER, CIRCUIT BRKR	1	
14	5R2-82501-01-00	MAIN SWCH STRGLCK	1	
15	97011-06020-00	BOLT	2	
16	92901-06600-00	WASHER	2	
17	3J0-82530-01-00	STOP SWITCH ASSEMBLY	1	
18	136-82540-00-00	NEUTRAL SWITCH ASSEMBLY	1	
19	37R-82543-00-00	GASKET	1	
20	437-83936-01-00	BAND, SWITCH CORD	2	
21	3J0-82590-50-00	WIRE HARNESS ASSEMBLY	1	
22	3J0-85720-00-00	OIL LVL GAUGE ASSEMBLY	1	
23	3Y1-83371-10-00	HORN	1	
24	97013-06012-00	BOLT	2	
25	92995-06100-00	WASHER, SPRING	2	

HANDLE SWITCH - LEVER

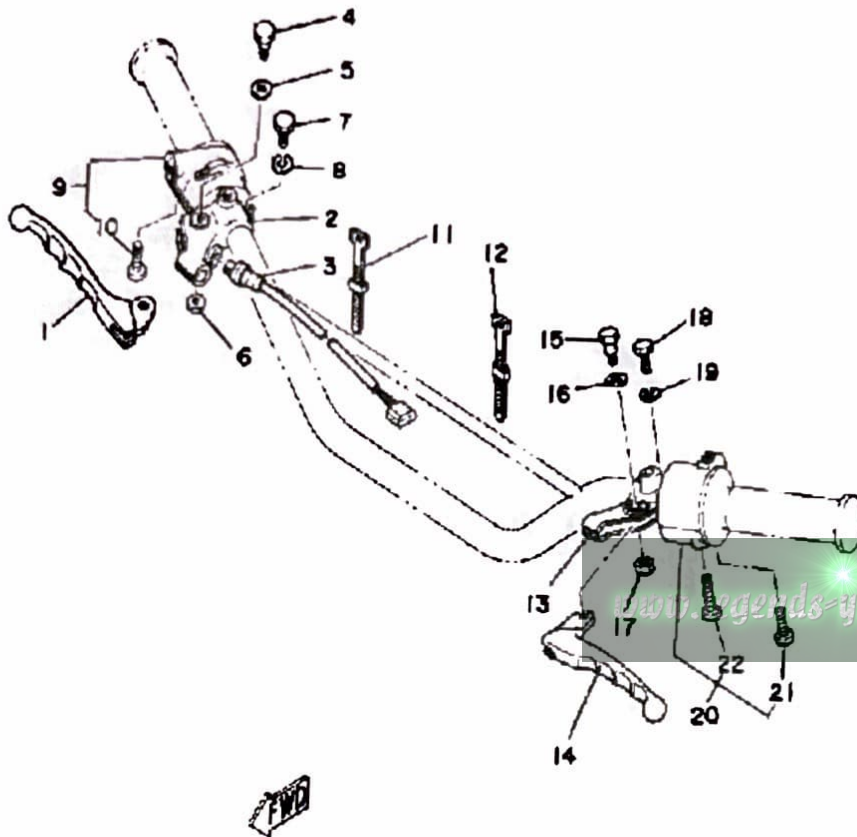

Ref. No.	Part Number	Description	Qty	Remarks
1	2H0-83922-30-00	LEVER R	1	LOW GLOSS BLK
2	361-82920-93-00	HOLDER, LEVER 2 (36182-92131-00)	1	
3	1M1-83980-30-00	STOP SWITCH ASSEMBLY	1	
4	90109-06797-00	BOLT	1	
5	90201-08083-00	WASHER, PLATE	1	
6	95601-06100-00	NUT, U	1	
7	97003-06022-00	BOLT, HEXAGON (97301-06022)	1	
8	92995-06100-00	WASHER, SPRING	1	
9	1R6-83976-01-00	SWITCH, HANDLE 1	1	
10	98580-05020-00	. SCREW, PAN HEAD	2	
11	437-83936-01-00	BAND, SWITCH CORD	2	
12	437-83936-01-00	BAND, SWITCH CORD	2	
13	3Y6-82911-00-00	HOLDER, LEVER 1	1	
14	2H0-83912-30-00	LEVER L	1	LOW GLOSS BLK
15	90109-06797-00	BOLT	1	
16	90201-08083-00	WASHER, PLATE	1	
17	95601-06100-00	NUT, U	1	
18	97003-06022-00	BOLT, HEXAGON (97301-06022)	1	
19	92995-06100-00	WASHER, SPRING	1	
20	1M1-83973-50-00	SWITCH, HANDLE 3	1	
21	98580-05020-00	. SCREW, PAN HEAD	1	
22	98501-05030-00	. SCREW, PAN HEAD	1	

DT175H 1981 SERVICE DATA

MODEL - IBM I.D. NUMBER	DT175H 3J1
Initial Engine Number / Frame Number	3J1-060101 / 3J1-060101
Basic Color(s)	Chappy Red
Fuel Type / Fuel Tank Capacity / Reserve Capacity	Regular / 6.8 Lit. (1.8 Gal.) / 0.9 Lit. (0.2 Gal.)
Dry Vehicle Weight	96 kg (216 lbs.)
ENGINE TYPE	2 Stroke, Air-Cooled, Reed Valve
Bore/Stroke/Number Cylinders/Displacement (cc)	66mm / 50mm / 1 / 171cc
Compression Ratio/Compression Pressure Min~Max	10.1:1 (6.8:1 Corrected) / \emptyset
Piston Skirt Clearance New / Max	0.040 ~ 0.045mm / 0.1mm
Ring End Gap Top / 2nd / 3rd	0.3 ~ 0.5mm / 0.3 ~ 0.5mm / \emptyset
Valve Clearance (Cold) Intake / Exhaust	\emptyset
Oil Pressure Hot / rpm	\emptyset
Oiling System	Autolube
Capacity: Dry	0.9 Lit. (0.9 Qt.)
Oil and Filter Change	\emptyset
Oil Change	\emptyset
Lubricant: Temp. Above 5°C (40°F)	Yamalube 2* or Equivalent
Temp. Below 15°C (60°F)	Yamalube 2* or Equivalent
AUTOLUBE - Min Stroke / Color Code	0.20 ~ 0.25mm / Gray
Minimum Output @ 200 Cycles	0.60cc
Maximum Output @ 200 Cycles	6.13cc
CARBURETOR - Mfr. / Type / I.D. Number	Mikuni / VM24SS / 3J1-00
Main Jet / Pilot Jet	150 / 22.5
Needle Jet / Jet Needle-Clip Position	N-4 / 5GL13 Fixed
Slide Cutaway or Throttle Valve	2.0
Floater Level / Fuel Level	21.0 ± 0.6mm / NA
Idle rpm	1350 ~ 1500 rpm
Max CO* / Max HC* / Set CO	\emptyset
SUSPENSION	
Front Forks: Oil Type / Level / Qty	10 Wt. Fork Oil* / \emptyset / 186cc
Gas Pressure	\emptyset
Spring Length Std	546.5mm
Monoshock: Oil Type / Qty	Not Rebuildable
Gas Pressure	15 kg/cm ² (213 psi)
Minimum Brake Lining Thickness	Front: 2mm Rear: 2mm
Tire Size (Nominal Pressure)	F:2.75-21 (1.7 kg/cm ² /28 psi) R:3.00-18 (2.0 kg/cm ² /28 psi)
TRANSMISSION - Oil Type/Qty Chg/Qty Reassemble	Yamalube 4* or SAE 10W30 SE / 650cc / 750cc
Primary Drive Type / Teeth / Ratio	Helical Gear / 71-22 / 3.227
Secondary Drive Type / Teeth / Chain	Chain / 49-16 / DID42BHM-118L
Clutch Friction Plate Thickness Std ~ Min	3.0 ~ 2.8mm
Clutch Spring Length Std ~ Min	33.0 ~ 32.0mm
Middle Gear Case Capacity	\emptyset
Final Gear Case Capacity	\emptyset
Gear Case Lubricant: Temp. Above 5°C (40°F)	\emptyset
Temp. Below 15°C (60°F)	\emptyset
All Weather Conditions	\emptyset

SERVICE COPY	SRV MGR	MECH	MECH	MECH	BINDER
OFFICE COPY	GEN MGR	SALES	PARTS	BINDER	*PAGE 1 OF 2

CHARGING SYSTEM	Flywheel Magneto / Single Phase / Half Wave
Battery: Model / Specific Gravity / Charge Rate	GS 6N6-3B-1 (6V 6AH) / 1.26 / 0.6A
Maximum Output	8.7V 2.5A @ 8000 rpm
TROUBLESHOOTING	
Field Coil Color Code / Ω	\emptyset
Charge Coil Color Code / Ω	Grn-Wht ~ Blk / 0.30 Ω ± 10%
IGNITION SYSTEM	Capacitor-Discharge Ignition
Ignition Timing	17.5° BTDC @ 3000 rpm (1.46mm BTDC)
Spark Plug Type	NGK B9ES
Spark Plug Gap / Torque / Cap Ω	0.6 ~ 0.8mm / 2.5 m·kg / 5K Ω ± 10%
Point Gap / Condenser Capacitance	\emptyset / \emptyset
TROUBLESHOOTING	
Ignition Coil Test Gap / Primary Ω / Secondary Ω	6mm / 1.0 Ω ± 10% / 5.9K Ω ± 20%
Pulser Coil or Pickup Coil Color Code / Ω	Wht-Red ~ Blk / 10 Ω ± 10%
Source Coil Color Code / Ω	Brn ~ Blk / 300 Ω ± 10%
LIGHTING SYSTEM	
Headlight / Taillight / Signal Rating	6V35-35W / 6V25-5.3W / 6V17W
TROUBLESHOOTING	
Lighting Coil Color Code / Ω	Yel ~ Blk / 0.18 Ω ± 10%
TORQUE VALUES	
Front Axle Nut	10 x 1.25: 3.7 m·kg
Front Axle Holder Nut	\emptyset
Rear Axle Nut	14 x 1.5: 8.5 m·kg
Rear Axle Pinch Bolt	\emptyset
Clutch Nut	14 x 1.0: 5.5 m·kg
Drain Plug	12 x 1.5: 2.0 m·kg
Cylinder Head Cover	\emptyset
Cylinder Head:	8 x 1.25: 2.5 m·kg
Engine Mounting Bolts: Front	8 x 1.25: 2.6 m·kg
Rear, Upper	8 x 1.25: 2.5 m·kg
Rear, Lower	10 x 1.25: 3.7 m·kg

\emptyset = Does Not Apply To This Model
NA = Information Not Available

*Available From Yamaha Parts Distributors Inc.
*For Diagnostic Use Only

PAGE 2 OF 2

CHARGING SYSTEM		Flywheel Magneto / Single Phase / Half Wave
Battery: Model / Specific Gravity / Charge Rate		GS 6N8-3B-1 (6V 6AH) / 1.26 / 0.6A
Maximum Output		6.7V 2.5A @ 8000 rpm
TROUBLESHOOTING		
Field Coil Color Code / Ω		\emptyset
Charge Coil Color Code / Ω		Grn-Wht ~ Blk / 0.30 Ω \pm 10%
IGNITION SYSTEM		Capacitor-Discharge Ignition
Ignition Timing		17.5° BTDC @ 3000 rpm (1.46mm BTDC)
Spark Plug Type		NGK B9ES
Spark Plug Gap / Torque / Cap Ω		0.6 ~ 0.8mm / 2.5 m·kg / BK Ω \pm 10%
Point Gap / Condenser Capacitance		\emptyset / \emptyset
TROUBLESHOOTING		
Ignition Coil Test Gap / Primary Ω / Secondary Ω		6mm / 1.0 Ω \pm 10% / 5.9K Ω \pm 20%
Pulser Coil or Pickup Coil Color Code / Ω		Wht-Red ~ Blk / 10 Ω \pm 10%
Source Coil Color Code / Ω		Brn ~ Blk / 300 Ω \pm 10%
LIGHTING SYSTEM		
Headlight / Taillight / Signal Rating		6V35-35W / 6V25-5.3W / 6V17W
TROUBLESHOOTING		
Lighting Coil Color Code / Ω		Yel ~ Blk / 0.18 Ω \pm 10%
TORQUE VALUES		
Front Axle Nut		10 x 1.25: 3.7 m·kg
Front Axle Holder Nut		\emptyset
Rear Axle Nut		14 x 1.5: 8.5 m·kg
Rear Axle Pinch Bolt		\emptyset
Clutch Nut		14 x 1.0: 5.5 m·kg
Drain Plug		12 x 1.6: 2.0 m·kg
Cylinder Head Cover		\emptyset
Cylinder Head		8 x 1.25: 2.6 m·kg
Engine Mounting Bolts: Front		8 x 1.25: 2.6 m·kg
Rear, Upper		8 x 1.25: 2.6 m·kg
Rear, Lower		10 x 1.25: 3.7 m·kg

\emptyset = Does Not Apply To This Model
NA = Information Not Available

*Available From Yamaha Parts Distributors Inc.
*For Diagnostic Use Only

www.legends-yamaha-enduros.com

www.legends-yamaha-enduros.com