

**YAMAHA**



**PARTS  
CATALOGUE**

**YZ80F (4ES3)**

**U.S.A.**



[www.tygenusa.yamaha-motor.com](http://www.tygenusa.yamaha-motor.com)

FIC-144ES-100E1

**YAMAHA**  
**GENUINE**  
Parts & Accessories

# FOREWORD

This Parts Catalogue is related to the parts in use for the Yamaha YZ80F(4ES3). When you are ordering replacement parts for the YZ80F(4ES3), refer to this Parts Catalogue and quote both part numbers and part names correctly.

1. Modifications or additions which have been made after issue of the Parts Catalogue will be announced in the Yamaha Parts News.

It is advisable that according to the Yamaha Parts News you make necessary corrections to the Parts Catalogue on hand to keep it up-to-date.

2. Abbreviations

The following abbreviations are used in this Parts Catalogue.

- U.R. Use size (thickness) and/or number as required.
- U.N. Use as many as you need.
- A.P. Alternate Parts
- L.M. Local Made
- F# Frame No. (Applicable machine No.)

3. The parts marked with (\*) in the parts number column of this Catalogue are not supplied with by Yamaha, those have to be found locally.

4. Parts, which are to be supplied in the form of assemblies, are listed with an indention of one letter's space, and a dot ( . ) is put against the name of each part.

**EXAMPLE**  
 CARBURETOR ASS'Y  
 . JET, pilot  
 . NOZZLE, main

5. Indication of No. of constituent parts for assembly

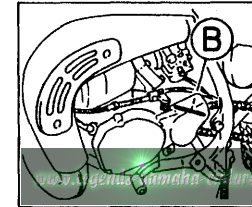
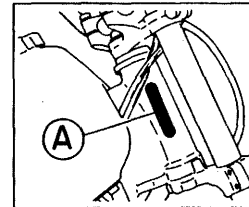
The numeral appearing to the right of each constituent part under the description indicates the quantity of such parts for each individual assembly unit.

**EXAMPLE**

Part No.	Description	Q'ty	Remarks
2F5-83310-60	FRONT FLASHER LIGHT ASS'Y	2	
115-83311-60	. BULB (6V-18W)	1	
1M1-83309-60	. REFLECTOR	1	

6. Initial Serial No. and Color Code

(A) Frame Serial No.	4ES-012101 and following
(B) Engine Serial No.	4ES-012101 and following



Color Code	Color Name	Abbreviate
0206	PURPLISH WHITE SOLID 1	PWS1

7. Applicable colors of graphics are represented in the "Remarks" column by the letter(s) appropriately picked out of the full word(s) showing such colors.

**EXAMPLE**

Part No.	Description	Q'ty	Remarks
2N4-24110-00-X5	FUEL TANK COMP.	1	MAXIM RED
3J1-24240-10	. GRAPHIC, fuel tank set	1	for MXR

# CONTENTS

## ENGINE

Cylinder .....	B2
Crankshaft, Piston .....	B3
Water Pump .....	B4
Radiator, Hose .....	B5
Intake .....	B6
Carburetor .....	B7~B8
Exhaust .....	B9
Crankcase .....	B10
Crankcase Cover 1 .....	B11
Starter .....	B12
Clutch .....	B13
Transmission .....	B14~B15
Shift Cam, Fork .....	C2
Shift Shaft .....	C3

## CHASSIS

Frame .....	C4
Fender .....	C5
Side Cover .....	C6
Rear Arm .....	C7~C8
Rear Suspension .....	C9
Steering .....	C10
Front Fork .....	C11~C12
Fuel Tank .....	C13
Seat .....	C14
Front Wheel .....	C15
Front Brake Caliper .....	D2
Rear Wheel .....	D3~D4
Rear Brake Caliper .....	D5

Steering Handle, Cable .....	D6
Front Master Cylinder .....	D7
Stand, Footrest .....	D8
Rear Master Cylinder .....	D9
Generator .....	D10
Handle Switch, Lever .....	D11
Electrical 1 .....	D12

## ALTERNATE PARTS

Alternate (Chassis) .....	D13
---------------------------	-----

## REPAIR KIT

Repair Kit .....	D14
------------------	-----

## INDEX

Numerical Index .....	M1~M3
-----------------------	-------

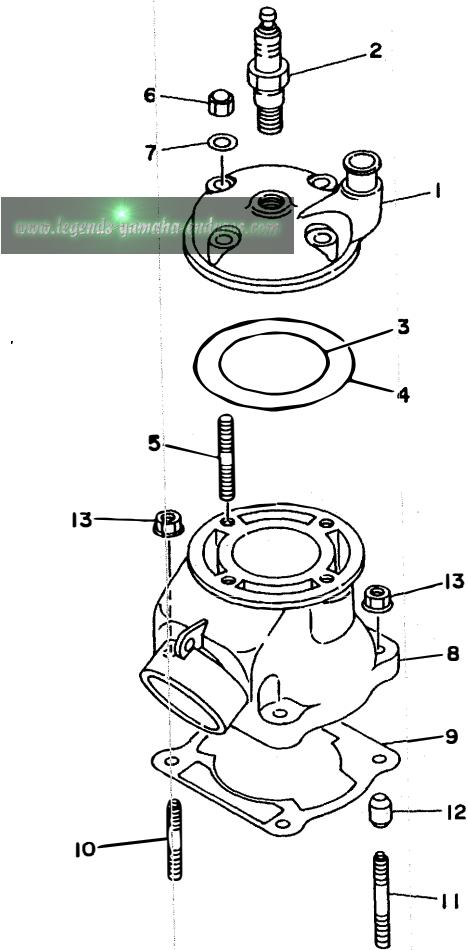


FIG. 1 CYLINDER

REF. NO.	PART NO.	DESCRIPTION	Q'TY	REMARKS
1	4ES-11111-00	HEAD, CYLINDER 1	1	
2	94702-00367	PLUG, SPARK (NGK B10EG)	1	UR
	94702-00368	PLUG, SPARK (NGK B10EG)	1	UR FOR CANADA,S.AFRICA
3	93210-56459	O-RING	1	
4	93210-84724	O-RING	1	
5	90116-08394	BOLT, STUD	4	
6	90176-08026	NUT, CROWN	4	
7	90201-08087	WASHER, PLATE	4	
8	4ES-11311-00	CYLINDER 1	1	
9	4ES-11351-00	GASKET, CYLINDER	1	
10	90116-08318	BOLT, STUD	2	
11	90116-08388	BOLT, STUD	2	
12	99510-10114	PIN, DOWEL	2	
13	90179-08491	NUT	4	



4ES1100-3010

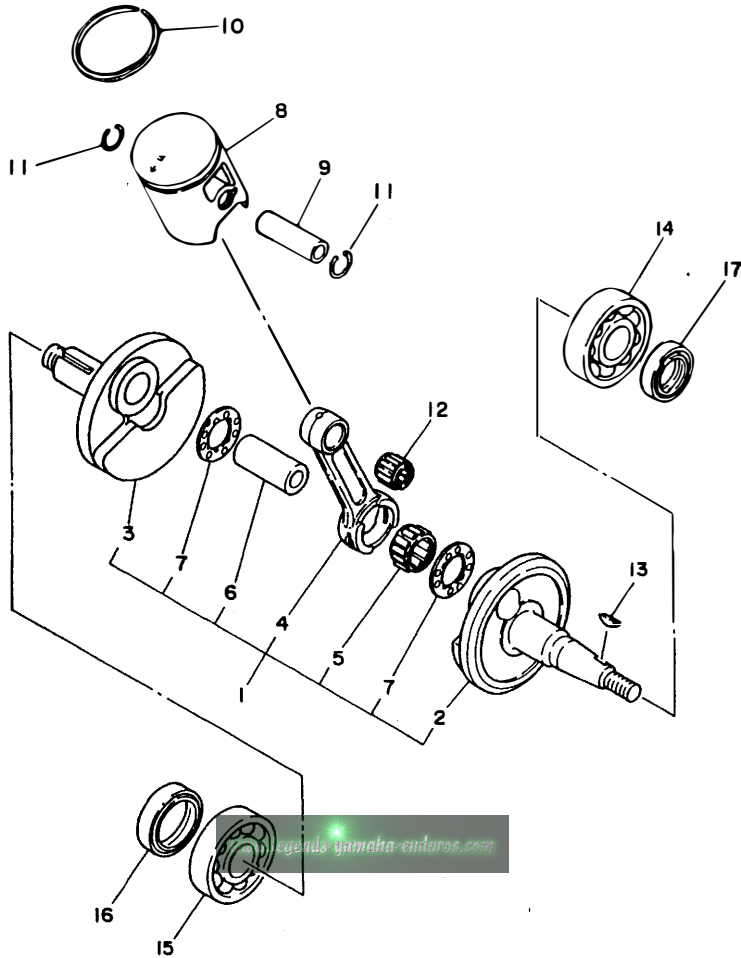


FIG. 2 CRANKSHAFT. PISTON

REF. NO.	PART NO.	DESCRIPTION	Q'TY	REMARKS
1	4ES-11400-02	CRANKSHAFT ASSY	1	
2	4ES-11412-00	.CRANK 1	1	
3	4ES-11422-00	.CRANK 2	1	
4	4ES-11651-01	.ROD, CONNECTING	1	
5	93310-320T3	.BEARING, CYLINDRICAL	1	
6	2RA-11681-00	.PIN, CRANK 1	1	
7	90209-20159	.WASHER	2	
8	4ES-11631-01-A0	PISTON (STD)	1	UR RED
	4ES-11631-01-B0	PISTON (STD)	1	UR ORANGE
	4ES-11631-01-C0	PISTON (STD)	1	UR GREEN
	4ES-11631-01-D0	PISTON (STD)	1	UR PURPLE
9	4ES-11633-00	PIN, PISTON	1	
10	43K-11611-00	RING, PISTON	1	
11	93450-16115	CIRCLIP	2	
12	93310-214F8	BEARING, CYLINDRICAL	1	KOYO
13	90280-03017	KEY, WOODRUFF	1	
14	93306-20468	BEARING	1	
15	93306-30421	BEARING (B6304C3)	1	
16	93103-28126	OIL SEAL	1	
17	93102-20447	OIL SEAL	1	



4ES1100-3020

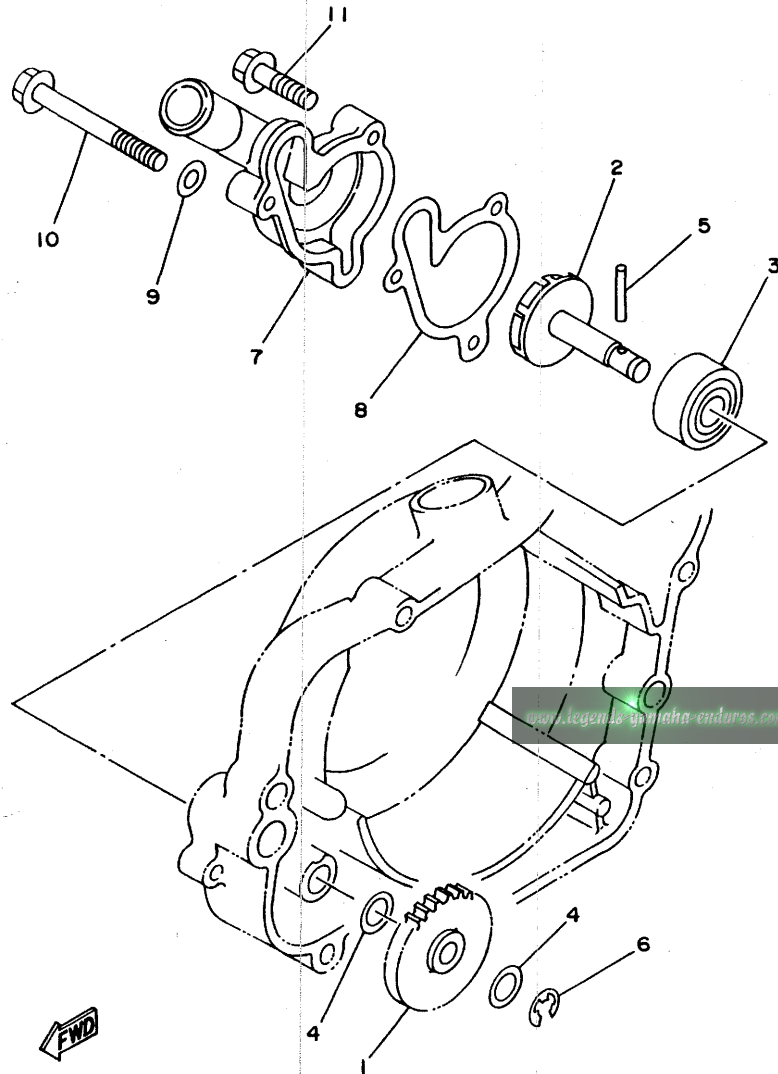
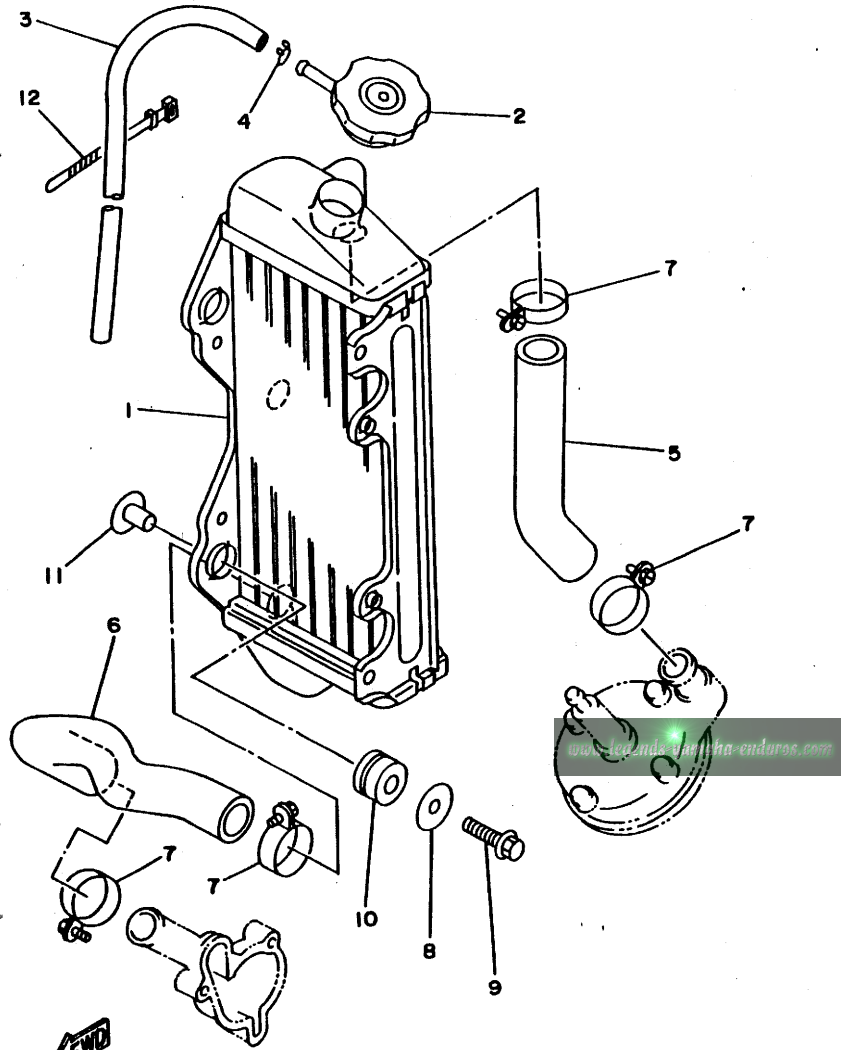


FIG. 3 WATER PUMP

REF. NO.	PART NO.	DESCRIPTION	Q'TY	REMARKS
1	4ES-12459-00	GEAR, IMPELLER SHAFT	1	
2	36F-12450-00	IMPELLER SHAFT ASSY	1	
3	93103-10168	OIL SEAL	1	
4	90201-08512	WASHER, PLATE	2	
5	93603-22028	PIN, DOWEL	1	
6	99080-07600	CIRCLIP	1	
7	4BA-12422-00	COVER, HOUSING	1	
8	4BA-12428-00	GASKET, HOUSING COVER 2	1	
9	90430-06166	GASKET	1	
10	95821-06060	BOLT, FLANGE	1	
11	95023-06025	BOLT	2	



4ES1100-3030



4ES1100-3040

FIG. 4 RADIATOR. HOSE

REF. NO:	PART NO.	DESCRIPTION	Q'TY	REMARKS
1	4ES-12461-00	RADIATOR ASSY	1	
2	22W-12462-00	CAP, RADIATOR	1	
3	22W-12463-00	PIPE, BREATHER	1	
4	90467-08004	CLIP	1	
5	4ES-12481-00	PIPE 1	1	
6	4ES-12482-00	PIPE 2	1	
7	90450-28014	HOSE CLAMP ASSY	4	
8	90201-06067	WASHER, PLATE	3	
9	95023-06030	BOLT	3	
10	90480-15528	GROMMET	3	
11	90387-0700G	COLLAR	3	
12	437-83936-01	BAND, SWITCH CORD	1	

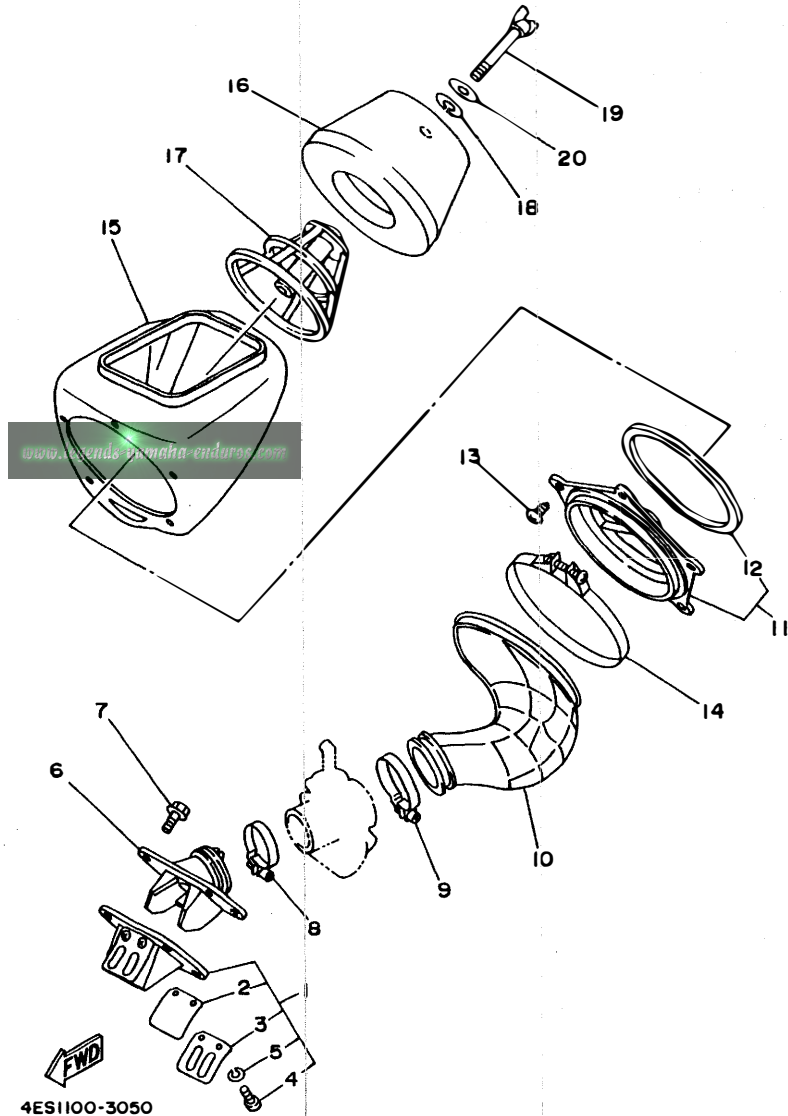
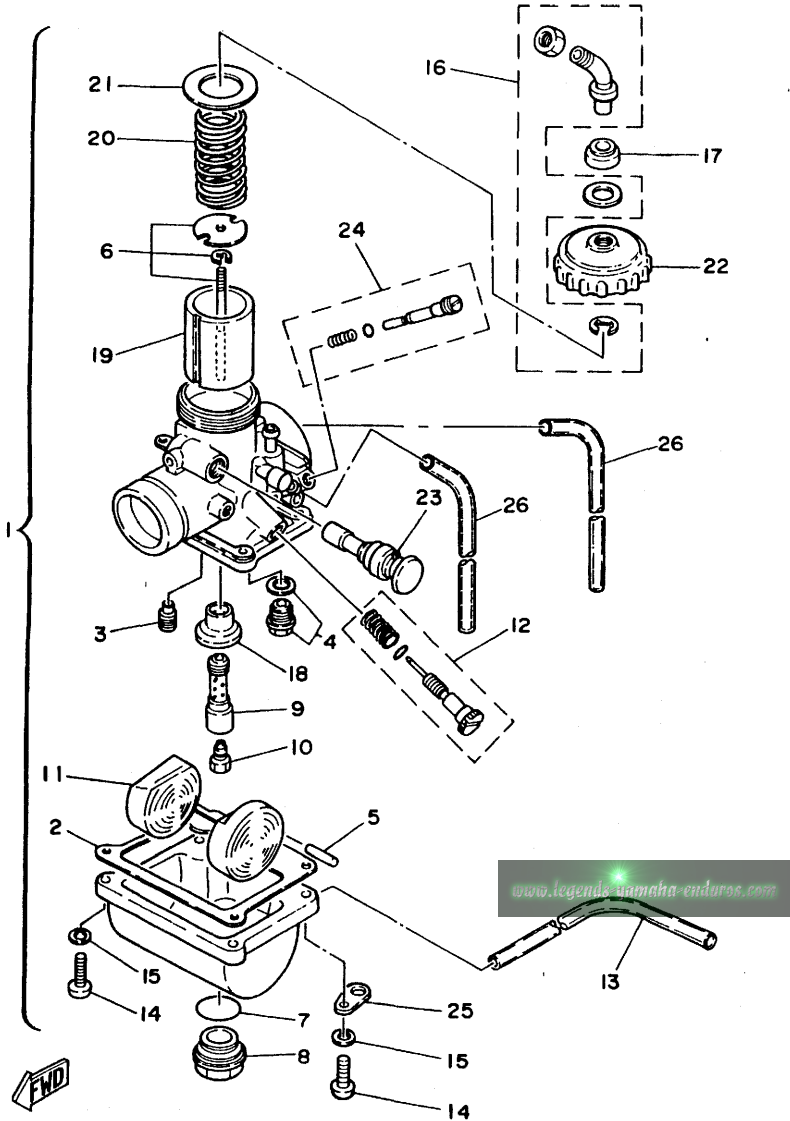


FIG. 5 INTAKE

REF. NO.	PART NO.	DESCRIPTION	Q'TY	REMARKS
1	4ES-13610-00	REED VALVE ASSY	1	
2	4ES-13613-00	.REED, VALVE	2	
3	4ES-13616-00	.STOPPER, REED VALVE	2	
4	98580-03008	.SCREW, PAN HEAD	4	
5	92990-03100	.WASHER, SPRING	4	
6	4ES-13565-00	JOINT, CARBURETOR	1	
7	95023-06020	BOLT	4	
8	90460-43053	CLAMP, HOSE	1	
9	90460-51059	CLAMP, HOSE	1	
10	4ES-14453-00	JOINT, AIR CLEANER 1	1	
11	4ES-14459-00	HOLDER, GUIDE	1	
12	4ES-14462-00	.SEAL	1	
13	90167-05031	SCREW, TAPPING	5	
14	90450-99064	HOSE CLAMP ASSY	1	
15	4ES-14411-00	CASE, AIR CLEANER 1	1	
16	4ES-14451-00	ELEMENT, AIR CLEANER	1	
17	4ES-14458-00	GUIDE	1	
18	90209-06096	WASHER	1	
19	90122-06034	BOLT, WING	1	
20	92995-06100	WASHER	1	





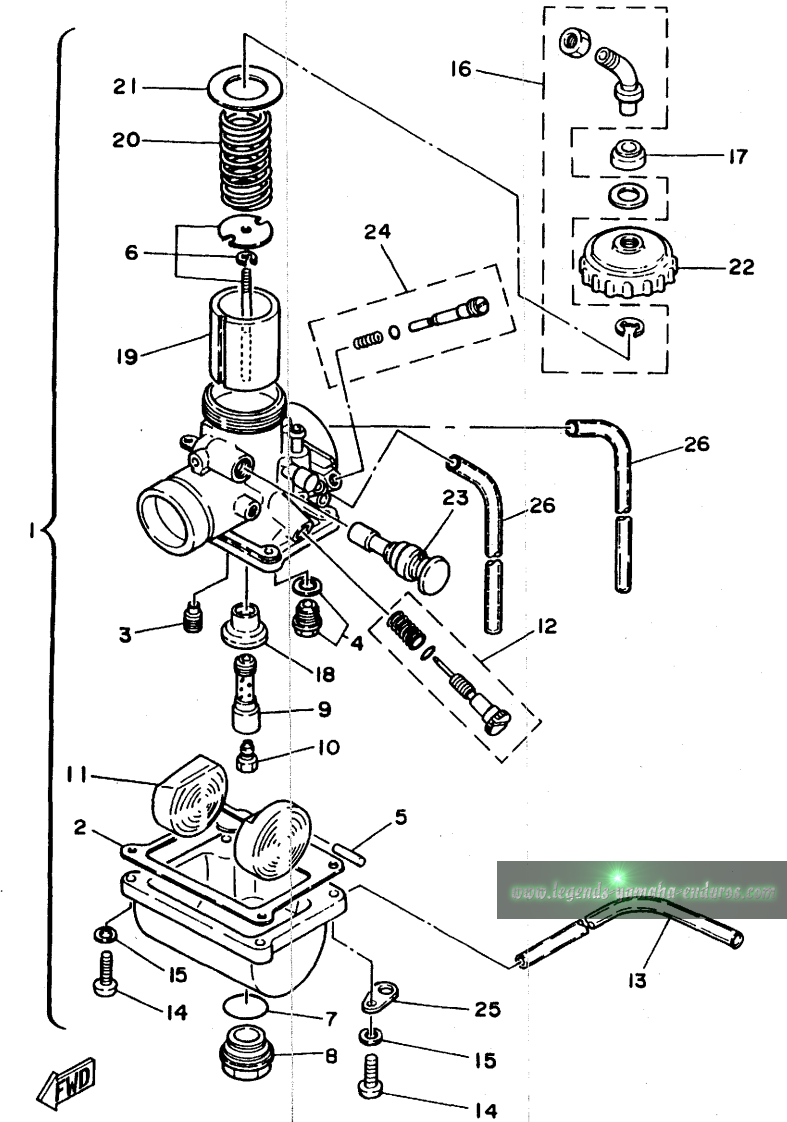
**FWD**  
4E51100-3060

**FIG. 6 CARBURETOR**

REF. NO.	PART NO.	DESCRIPTION	Q'TY	REMARKS
1	4E5-14101-01	CARBURETOR ASSY 1	1	
2	304-14184-00	.GASKET, FLOAT CHAMBER	1	
3	260-14142-35	.JET, PILOT (# 35)	1	STD
	260-14142-30	.JET, PILOT (# 30)	1	AP
	260-14142-40	.JET, PILOT (# 40)	1	AP
4	23L-14107-25	.NEEDLE VALVE SET	1	
5	127-14186-00	.PIN, FLOAT	1	
6	58T-1490J-00	.NEEDLE SET	1	
7	93210-18288	.O-RING	1	
8	3R1-14115-00	.PLUG, SCREW	1	
9	3R1-14141-52	.NOZZLE, MAIN	1	STD
	3R1-14141-50	.NOZZLE, MAIN	1	AP
	3R1-14141-54	.NOZZLE, MAIN	1	AP
10	137-14143-58-A1	.JET, MAIN (#290)	1	STD
	137-14143-56-A0	.JET, MAIN (#280)	1	AP
	137-14143-60-A0	.JET, MAIN (#300)	1	AP
11	314-14185-00	.FLOAT	1	
12	31J-14103-00	.THROTTLE SCREW SET	1	
13	278-14197-00	.PIPE	1	
14	98511-04016	.SCREW, PAN HEAD	4	
15	92902-04100	.WASHER, SPRING	4	
16	22W-14106-00	.CABLE ADJUST SCREW SET	1	
17	3X3-14169-00	.CAP	1	
18	39K-14153-00	.WASHER, MAIN JET	1	
19	2X6-14112-30	.VALVE, THROTTLE 1	1	STD
	2X6-14112-25	.VALVE, THROTTLE 1	1	AP
	2X6-14112-35	.VALVE, THROTTLE 1	1	AP
20	248-14131-00	.SPRING, THROTTLE VALVE	1	

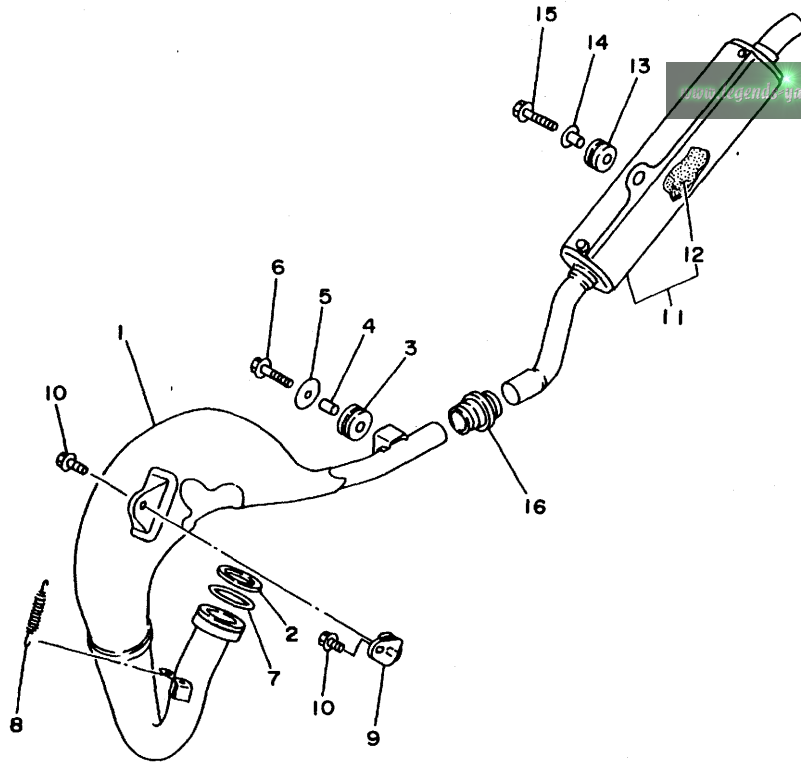
FIG. 6 CARBURETOR

REF. NO.	PART NO.	DESCRIPTION	Q'TY	REMARKS
21	2A6-14126-00	.GASKET	1	
22	2A6-14158-00	.TOP, MIXING CHAMBER	1	
23	3SB-14171-00	.PLUNGER, STARTER	1	
24	10W-14104-00	.AIR SCREW SET	1	
25	132-14146-00	.PLATE	1	
26	55X-14196-00	.PIPE	2	



4ES1100-3060

FIG. 7 EXHAUST



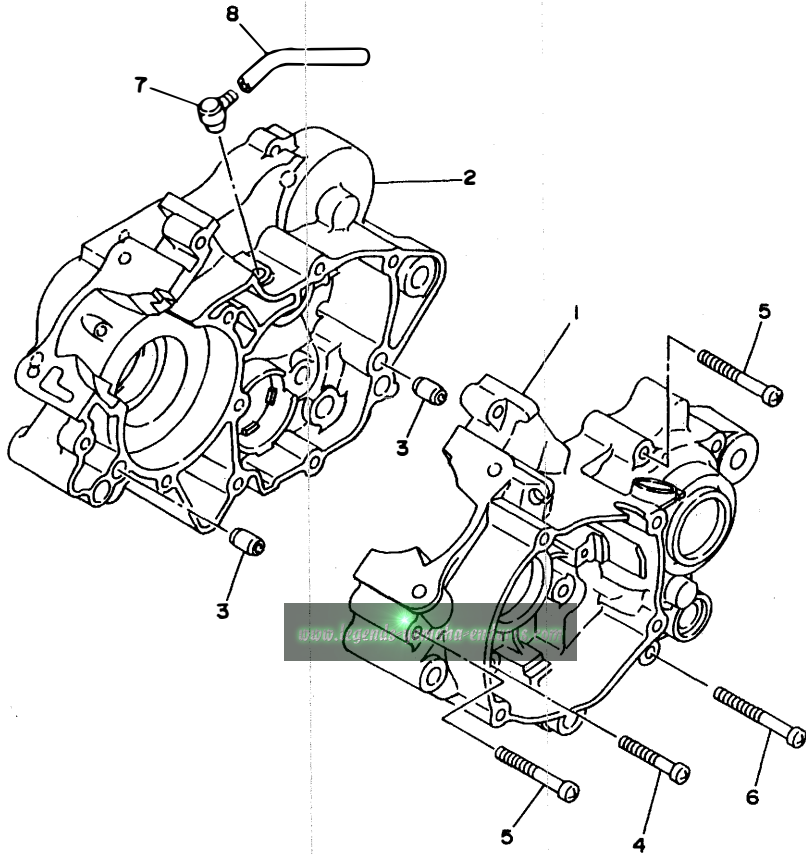
REF. NO.	PART NO.	DESCRIPTION	Q'TY	REMARKS
1	4ES-14610-00	EXHAUST PIPE ASSY 1	1	
2	90201-33299	WASHER, PLATE	1	
3	90480-18411	GROMMET	1	
4	90387-105L0	COLLAR	1	
5	90201-060A3	WASHER, PLATE	1	
6	95023-06025	BOLT	1	
7	93210-371A9	O-RING	1	
8	90507-20030	SPRING, TENSION	1	
9	565-14771-00	STAY, MUFFLER 1	1	
10	95023-06012	BOLT	2	
11	4ES-14753-00	SILENCER, EXHAUST	1	
12	4ES-1469A-00	.FIBER	1	
13	90480-16561	GROMMET	1	
14	90387-063G3	COLLAR	1	
15	95023-06025	BOLT	1	
16	17W-14615-00	JOINT, EXHAUST 1	1	



4ES3100-4070

FIG. 8 CRANKCASE

REF. NO.	PART NO.	DESCRIPTION	Q'TY	REMARKS
1	4ES-15111-00	CRANKCASE 1	1	
2	4ES-15121-01	CRANKCASE 2	1	
3	99530-10014	PIN, DOWEL	2	
4	98580-06040	SCREW, PAN HEAD	3	
5	98580-06550	SCREW, PAN HEAD	5	
6	92580-06560	SCREW, PAN HEAD	3	
7	583-15371-00	BREATHER	1	
8	90446-07349	HOSE	1	



4ES1100-3080

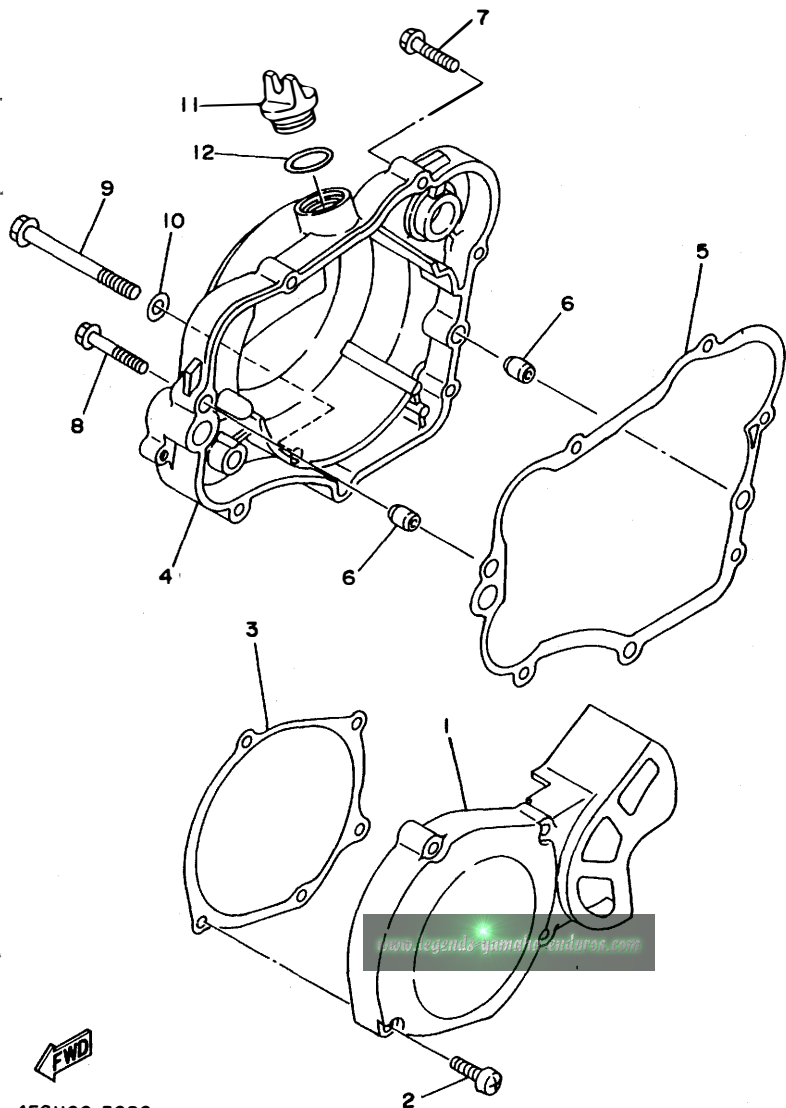


FIG. 9 CRANKCASE COVER 1

REF. NO.	PART NO.	DESCRIPTION	Q'TY	REMARKS
1	4ES-15411-00	COVER, CRANKCASE 1	1	
2	98580-06030	SCREW, PAN HEAD	4	
3	4ES-15451-00	GASKET, CRANKCASE COVER 1	1	
4	4ES-15421-00	COVER, CRANKCASE 2	1	
5	4ES-15461-00	GASKET, CRANKCASE COVER 2	1	
6	99530-10014	PIN, DOWEL	2	
7	95023-06030	BOLT	4	
8	95023-06040	BOLT	1	
9	95021-08080	BOLT, FLANGE	1	
10	90201-08087	WASHER, PLATE	1	
11	1RG-15363-00	PLUG, OIL	1	
12	93210-19123	O-RING	1	



4ES1100-3090

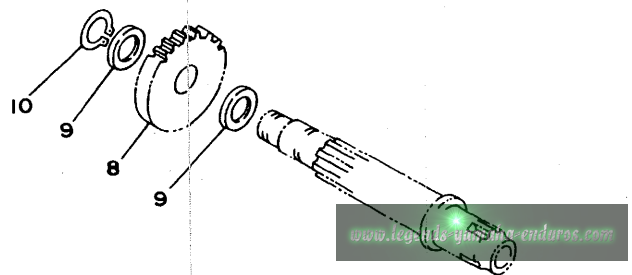
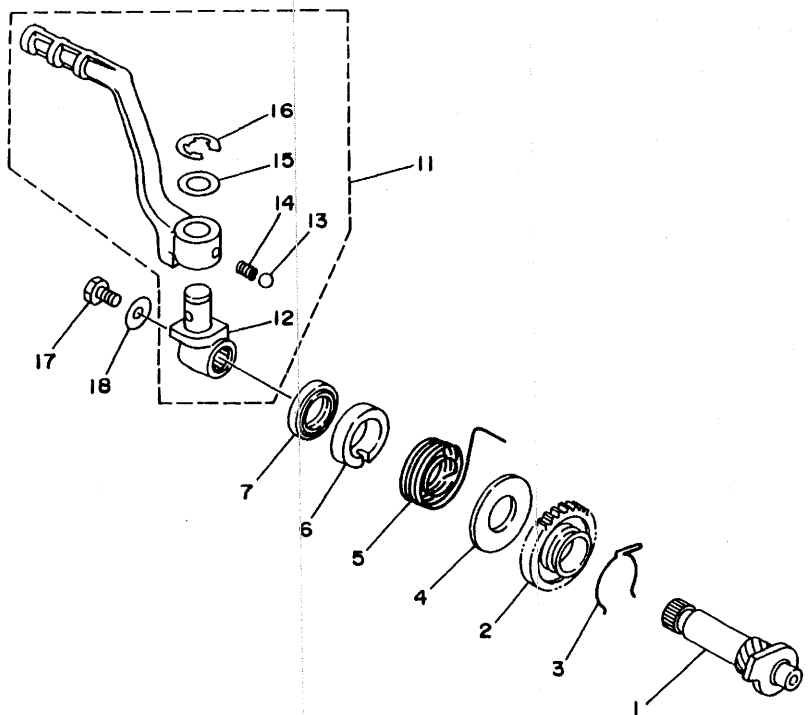


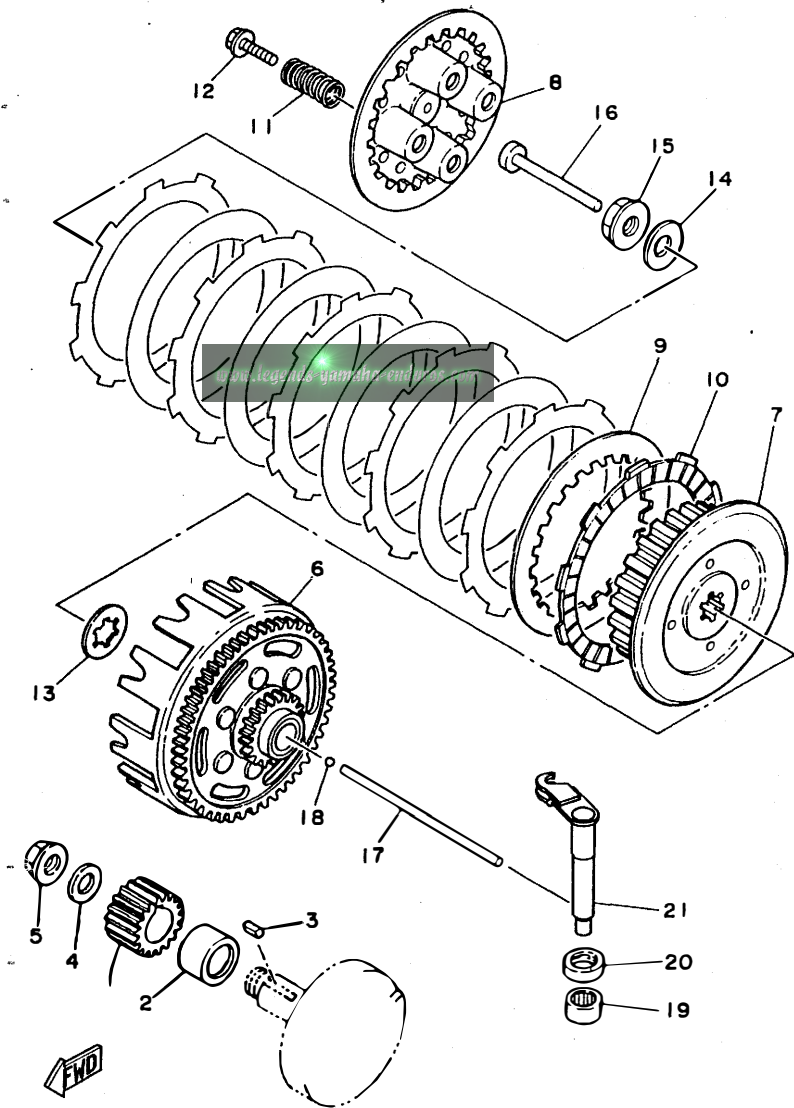
FIG. 10 STARTER

REF. NO.	PART NO.	DESCRIPTION	Q'TY	REMARKS
1	4ES-15660-00	KICK AXLE ASSY	1	
2	4ES-15641-00	GEAR, KICK	1	
3	90468-23194	CLIP	1	
4	90201-176L4	WASHER, PLATE	1	
5	90508-26750	SPRING, TORSION	1	
6	4ES-15664-00	GUIDE, SPRING	1	
7	93102-17263	OIL SEAL	1	
8	4ES-15651-00	GEAR, KICK IDLE	1	
9	90201-124F8	WASHER, PLATE	2	
10	99009-12400	CIRCLIP	1	
11	4ES-15620-00	KICK CRANK ASSY	1	
12	4ES-15621-00	.BOSS, KICK CRANK	1	
13	93507-32031	.BALL	1	
14	90501-12081	.SPRING, COMPRESSION	1	
15	90201-12631	.WASHER, PLATE	1	
16	93430-08007	.CIRCLIP	1	
17	95023-06012	BOLT	1	
18	90201-065F3	WASHER, PLATE	1	



4ES1100-3100

www.legendaryenduros.com



4ES1100-3110

FIG. 11 CLUTCH

REF. NO.	PART NO.	DESCRIPTION	Q'TY	REMARKS
1	4ES-16111-00	GEAR, PRIMARY DRIVE	1	
2	90387-20488	COLLAR	1	
3	90282-05001	KEY, STRAIGHT	1	
4	90208-12015	WASHER, CONICAL SPRING	1	
5	90179-12244	NUT	1	
6	4ES-16150-00	PRIMARY DRIVEN GEAR COMP.	1	
7	1LR-16371-00	BOSS, CLUTCH	1	
8	1LR-16351-00	PLATE, PRESSURE 1	1	
9	257-16324-00	PLATE, CLUTCH 1	5	
10	4ES-16321-00	PLATE, FRICTION	6	
11	90501-20361	SPRING, COMPRESSION	4	
12	90159-05011	SCREW, WITH WASHER	4	
13	4V0-16154-00	PLATE, THRUST 1	1	
14	90208-12015	WASHER, CONICAL SPRING	1	
15	90179-12244	NUT	1	
16	4ES-16356-00	ROD, PUSH 1	1	
17	2X3-16357-00	ROD, PUSH 2	1	
18	93503-16010	BALL	1	
19	93315-11206	BEARING, CYLINDRICAL	1	
20	93102-12224	OIL SEAL	1	
21	4ES-16381-00	PUSH LEVER COMP.	1	

FIG. 12 TRANSMISSION

REF. NO.	PART NO.	DESCRIPTION	Q'TY	REMARKS
1	4ES-17411-00	AXLE, MAIN	1	
2	4ES-17151-00	GEAR, 5TH PINION	1	
3	4ES-17131-00	GEAR, 3RD PINION	1	
4	4ES-17161-00	GEAR, 6TH PINION	1	
5	4ES-17121-00	GEAR, 2ND PINION	1	
6	93440-17064	CIRCLIP	3	
7	90201-065F3	WASHER, PLATE	2	
8	90157-06071	SCREW, PAN HEAD	2	
9	4ES-17421-00	AXLE, DRIVE	1	
10	4ES-17221-00	GEAR, 2ND WHEEL	1	
11	4ES-17261-00	GEAR, 6TH WHEEL	1	
12	4ES-17231-00	GEAR, 3RD WHEEL	1	
13	4ES-17241-00	GEAR, 4TH WHEEL	1	
14	4ES-17251-00	GEAR, 5TH WHEEL	1	
15	4ES-17211-01	GEAR, 1ST WHEEL	1	
16	93410-20038	CIRCLIP	2	
17	90201-203E7	WASHER, PLATE	1	
18	164-17427-00-06	SHIM 1 (0.6T)	1	
19	93440-15012	CIRCLIP	1	
20	93306-20333	BEARING	1	
21	93317-11245	BEARING, CYLINDRICAL	1	
22	93315-31502	BEARING, CYLINDRICAL	1	
23	93306-20421	BEARING (B6204)	1	
24	93102-20143	OIL SEAL	1	
25	93822-14037	SPROCKET, DRIVE 14T (1741746140)	1	STD
	93822-12012	SPROCKET, DRIVE 12T (1741746120)	1	AP
	93822-13024	SPROCKET, DRIVE 13T (1741746130)	1	STD Y280LW MODEL
	93822-15065	SPROCKET, DRIVE 15T (1741746150)	1	AP

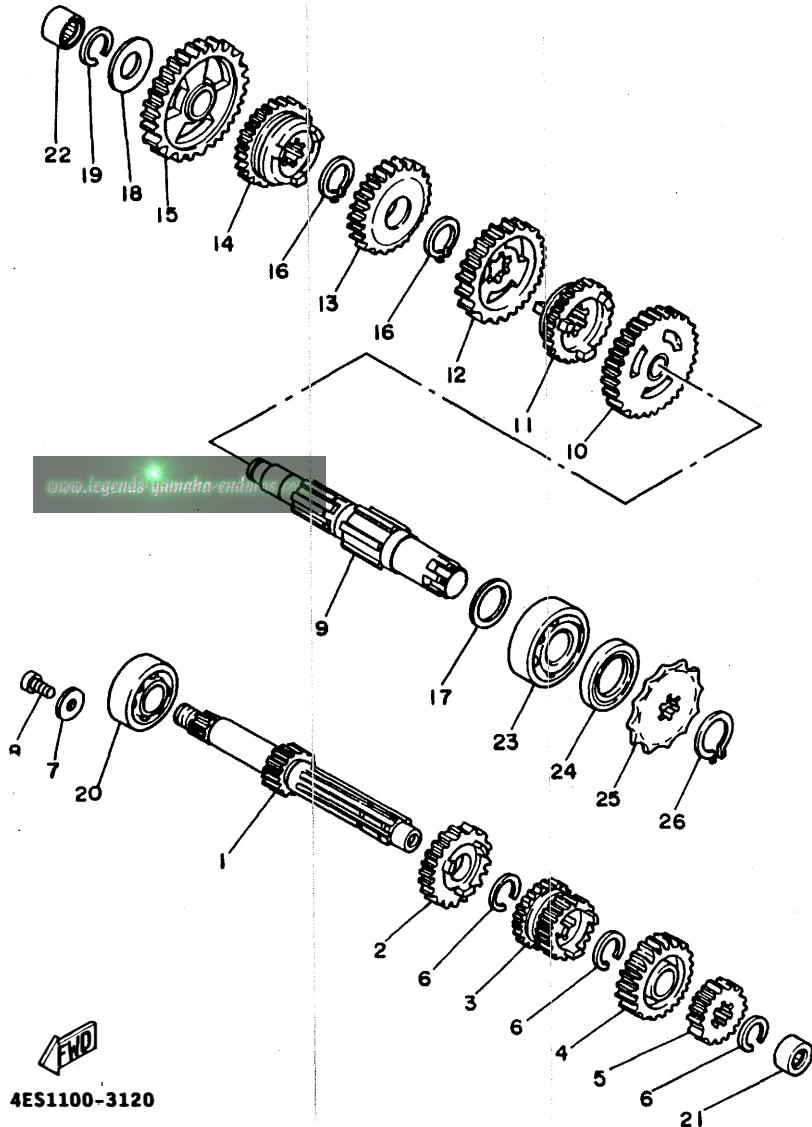
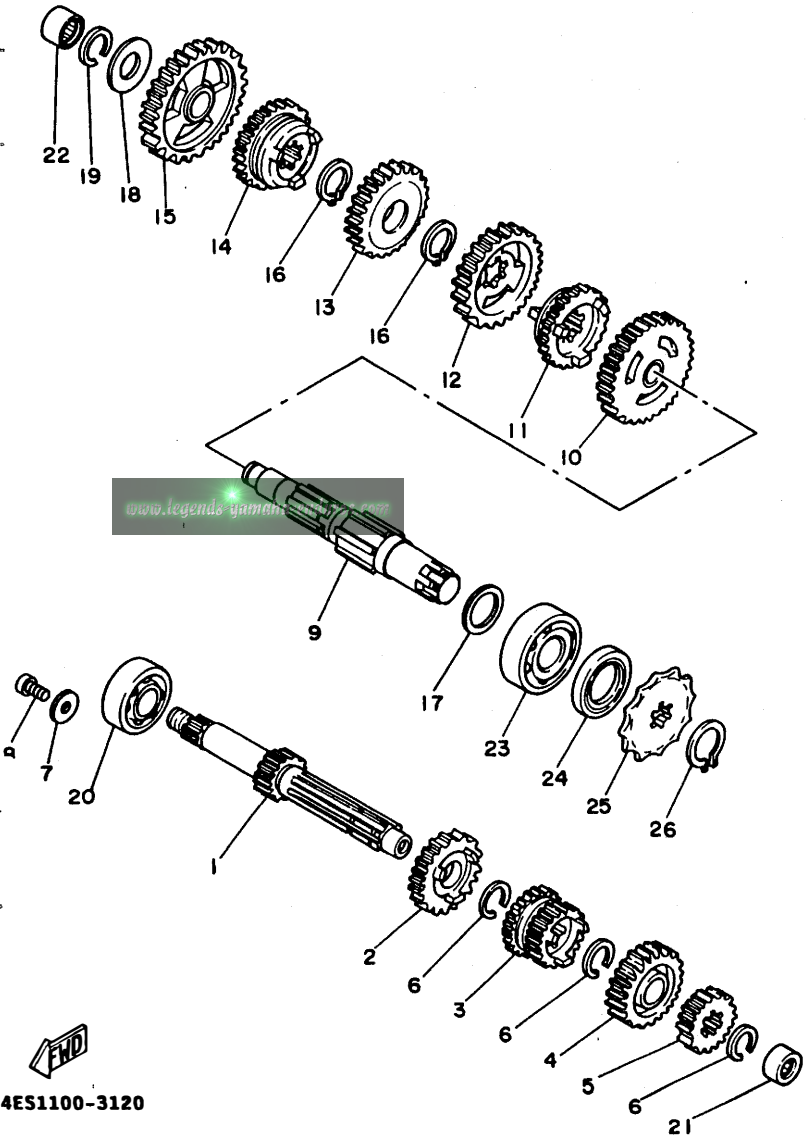




FIG. 12 TRANSMISSION



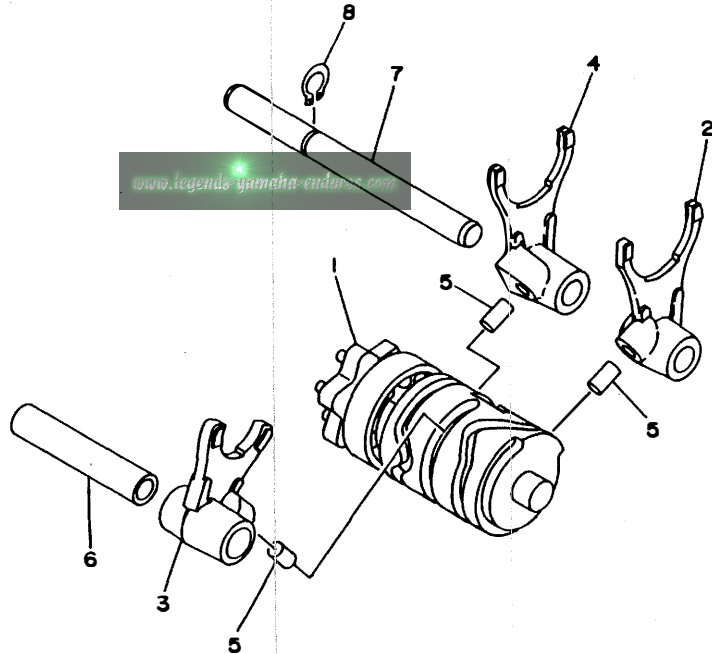
REF. NO.	PART NO.	DESCRIPTION	Q'TY	REMARKS
----------	----------	-------------	------	---------

26	99009-18400	CIRCLIP	1	
----	-------------	---------	---	--

  
4ES1100-3120

FIG. 13 SHIFT CAM. FORK

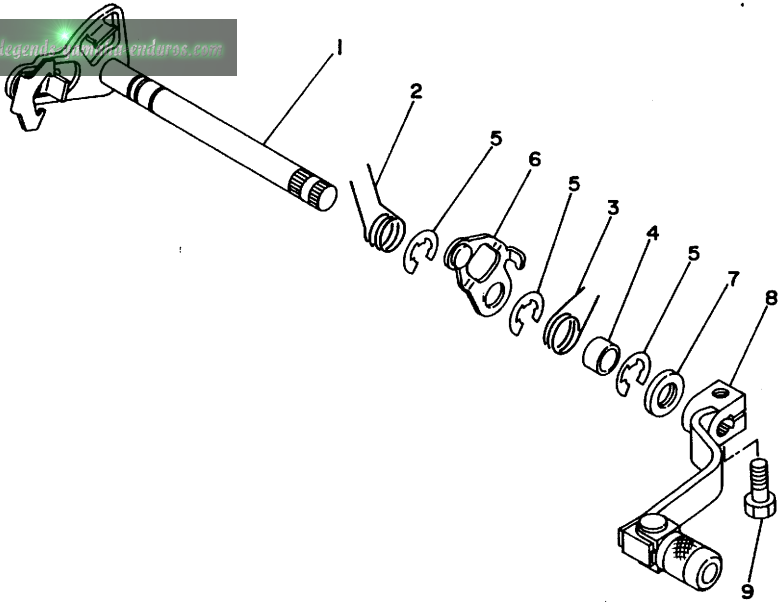
REF. NO.	PART NO.	DESCRIPTION	Q'TY	REMARKS
1	4ES-18540-00	SHIFT CAM ASSY	1	
2	4ES-18511-00	FORK, SHIFT 1	1	
3	4V0-18512-00	FORK, SHIFT 2	1	
4	4ES-18513-00	FORK, SHIFT 3	1	
5	90250-06013	PIN, STRAIGHT	3	
6	4BA-18531-00	BAR, SHIFT FORK GUIDE 1	1	
7	4BA-18535-00	BAR, SHIFT FORK GUIDE 2	1	
8	99009-10400	CIRCLIP	1	



4ES3100-4130

FIG. 14 SHIFT SHAFT

REF. NO.	PART NO.	DESCRIPTION	Q'TY	REMARKS
1	4ES-18101-00	SHIFT SHAFT ASSY	1	
2	90508-32553	SPRING, TORSION	1	
3	90508-242A6	SPRING, TORSION	1	
4	90387-126Y7	COLLAR	1	
5	99006-10600	CIRCLIP	3	
6	4BA-18140-00	STOPPER LEVER ASSY	1	
7	93101-12060	OIL SEAL	1	
8	2HF-18110-01	SHIFT PEDAL ASSY	1	
9	97011-06020	BOLT	1	



www.legendsenduros.com



4ES1100-3140

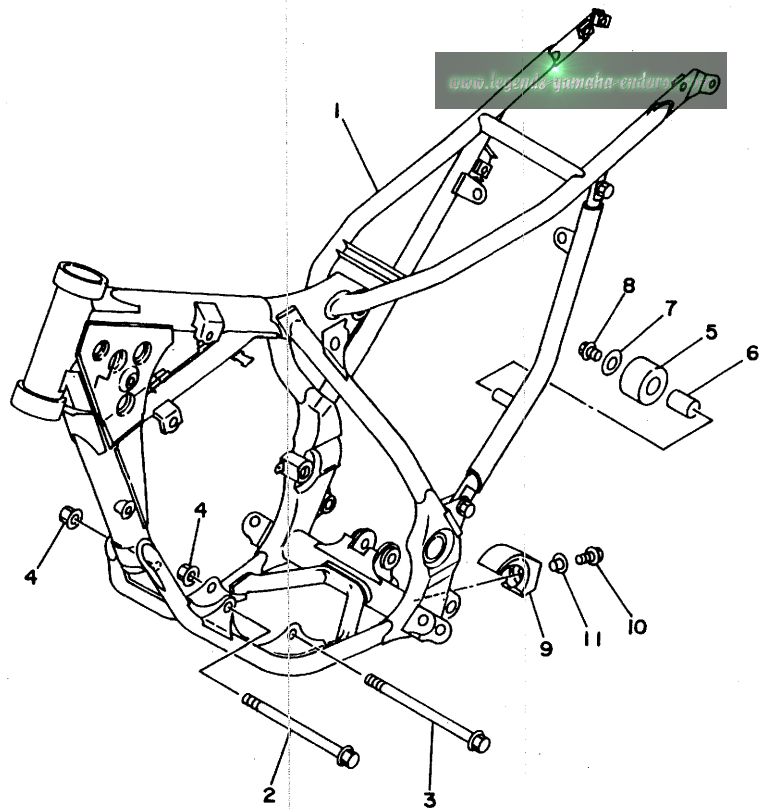


FIG. 15 FRAME

REF. NO.	PART NO.	DESCRIPTION	Q'TY	REMARKS
1	4ES-21110-01-PO	FRAME COMP.	1	DEEP VIOLET SOLID 1
2	91011-08125	BOLT, FLANGE	1	
3	91011-08135	BOLT, FLANGE	1	
4	95601-08200	NUT, SELF-LOCKING	2	
5	30X-22178-00	TENSIONER	1	
6	4V4-22184-00	BUSH	1	
7	90201-081R9	WASHER, PLATE	1	
8	95023-08012	BOLT	1	
9	4ES-22178-00	TENSIONER	1	
10	90119-06118	BOLT, WITH WASHER	1	
11	90387-06216	COLLAR	1	



4ES1100-3150

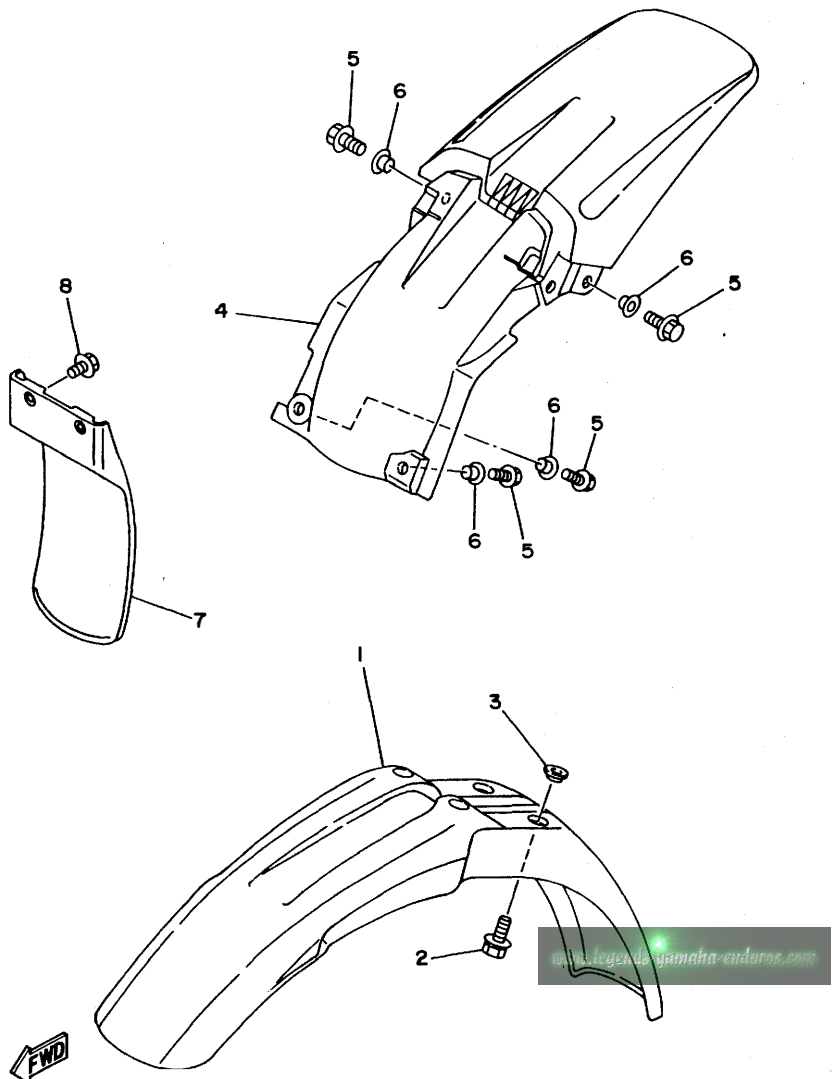
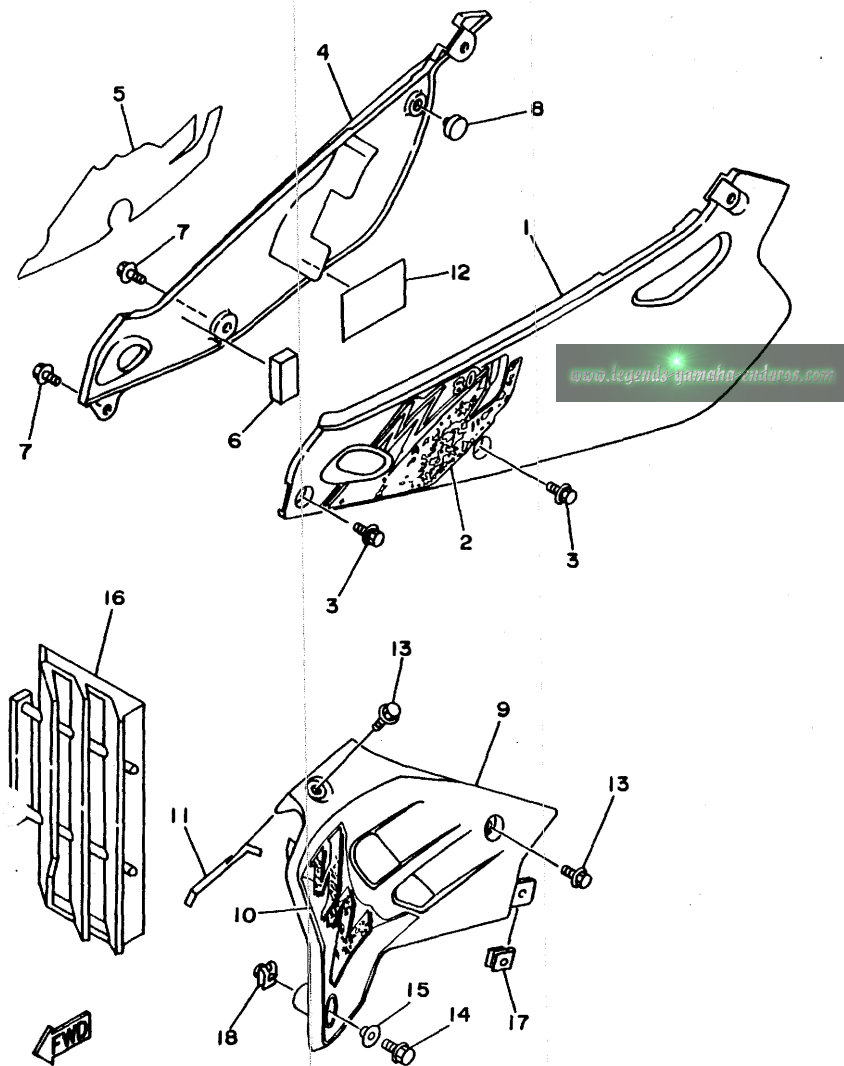


FIG. 16 FENDER

REF. NO.	PART NO.	DESCRIPTION	Q'TY	REMARKS
1	4ES-21511-00	FENDER, FRONT	1	
2	90119-06063	BOLT, WITH WASHER	4	
3	90209-06187	WASHER	4	
4	4ES-21611-00	FENDER, REAR	1	
5	95023-06016	BOLT	4	
6	90387-064X4	COLLAR	4	
7	4ES-21642-00	GUARD, FLAP	1	
8	90119-06185	BOLT, WITH WASHER	2	

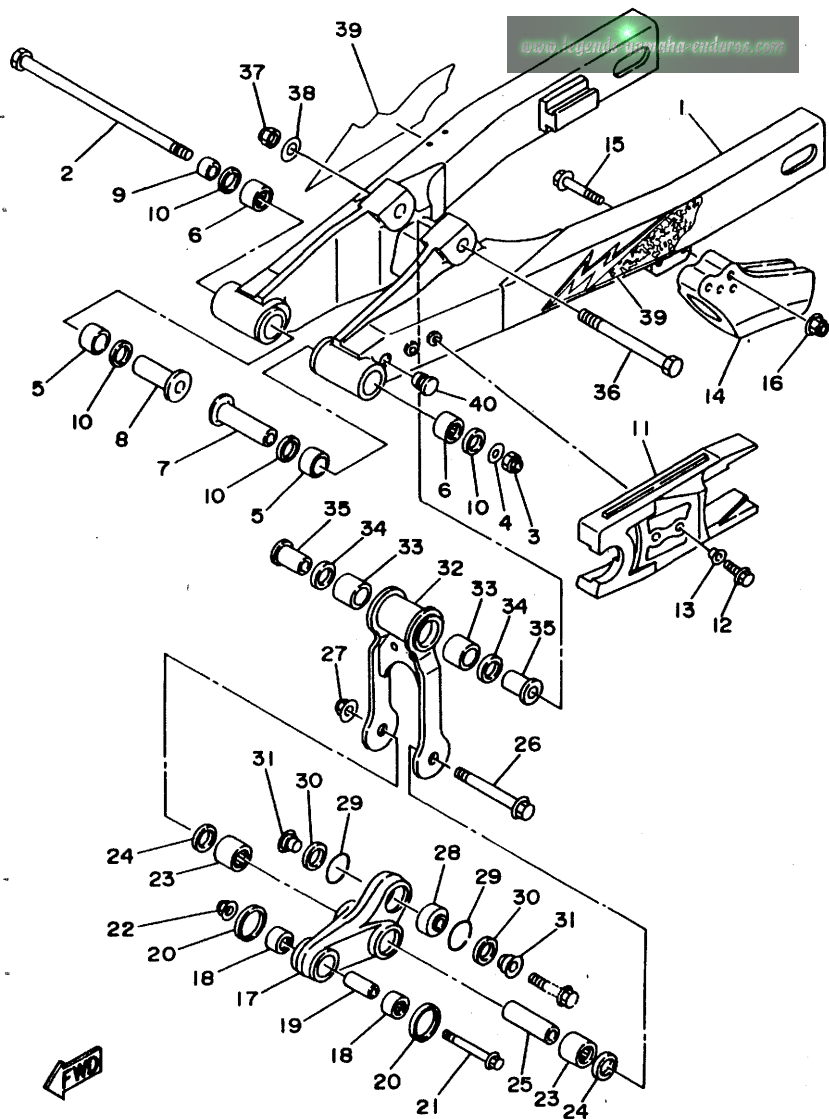
 4ES1100-3160



4ES3100-4170

FIG. 17 SIDE COVER

REF. NO.	PART NO.	DESCRIPTION	Q'TY	REMARKS
1	4ES-21711-00	COVER, SIDE 1	1	
2	4ES-2173E-00	GRAPHIC 1	1	
3	90119-06217	BOLT, WITH WASHER	2	
4	4ES-21721-00	COVER, SIDE 2	1	
5	4ES-2173F-00	GRAPHIC 2	1	
6	4ES-21735-00	SEAL 2	1	
7	90119-06217	BOLT, WITH WASHER	2	
8	22W-24181-00	DAMPER, LOCATING 1	1	
9	4ES-21731-00	COVER, SIDE 3	1	
10	4ES-21783-10	EMBLEM 3	1	
11	4ES-21732-00	SEAL 1	1	
12	4DJ-2174A-00	INSULATOR, SIDE COVER	1	
13	90109-067F4	BOLT	2	
14	95023-06016	BOLT	1	
15	90387-062M9	COLLAR	1	
16	4EW-2172A-00	PANEL 1	1	
17	90183-06023	NUT, SPRING	1	
18	90183-06069	NUT, SPRING	1	



4ES3100-4180

FIG. 18 REAR ARM

REF. NO.	PART NO.	DESCRIPTION	Q'TY	REMARKS
1	4ES-22110-00	REAR ARM COMP.	1	UR
	4LB-22110-00	REAR ARM COMP.	1	UR YZ80LW MODEL
2	22W-25181-01	AXLE, WHEEL	1	
3	90185-12119	NUT, SELF-LOCKING	1	
4	90201-12469	WASHER, PLATE	1	
5	90385-17042	BUSH	2	
6	93317-21746	BEARING, CYLINDRICAL	2	
7	90387-127J8	COLLAR	1	
8	90387-127J7	COLLAR	1	
9	90387-1200U	COLLAR	1	
10	93109-17048	OIL SEAL (SDO 17-24-4)	4	
11	4ES-22151-00	SEAL, GUARD	1	
12	95021-06014	BOLT, FLANGE	2	
13	90387-062X0	COLLAR	2	
14	39K-22199-00	SUPPORT, CHAIN	1	
15	90105-08310	BOLT, WASHER BASED	2	
16	95601-08200	NUT, SELF-LOCKING	2	
17	4ES-2217A-00	ARM, RELAY	1	
18	93315-31449	BEARING, CYLINDRICAL	2	
19	90380-10218	BUSH, SOLID	1	
20	4ES-22129-00	COVER, THRUST 2	2	
21	90105-10582	BOLT, WASHER BASED	1	
22	95601-10200	NUT, SELF-LOCKING	1	
23	93315-31748	BEARING, CYLINDRICAL	2	
24	93101-17062	OIL SEAL	2	
25	90380-12219	BUSH, SOLID	1	
26	90105-12382	BOLT, WASHER BASED	1	
27	95601-12200	NUT, SELF-LOCKING	1	

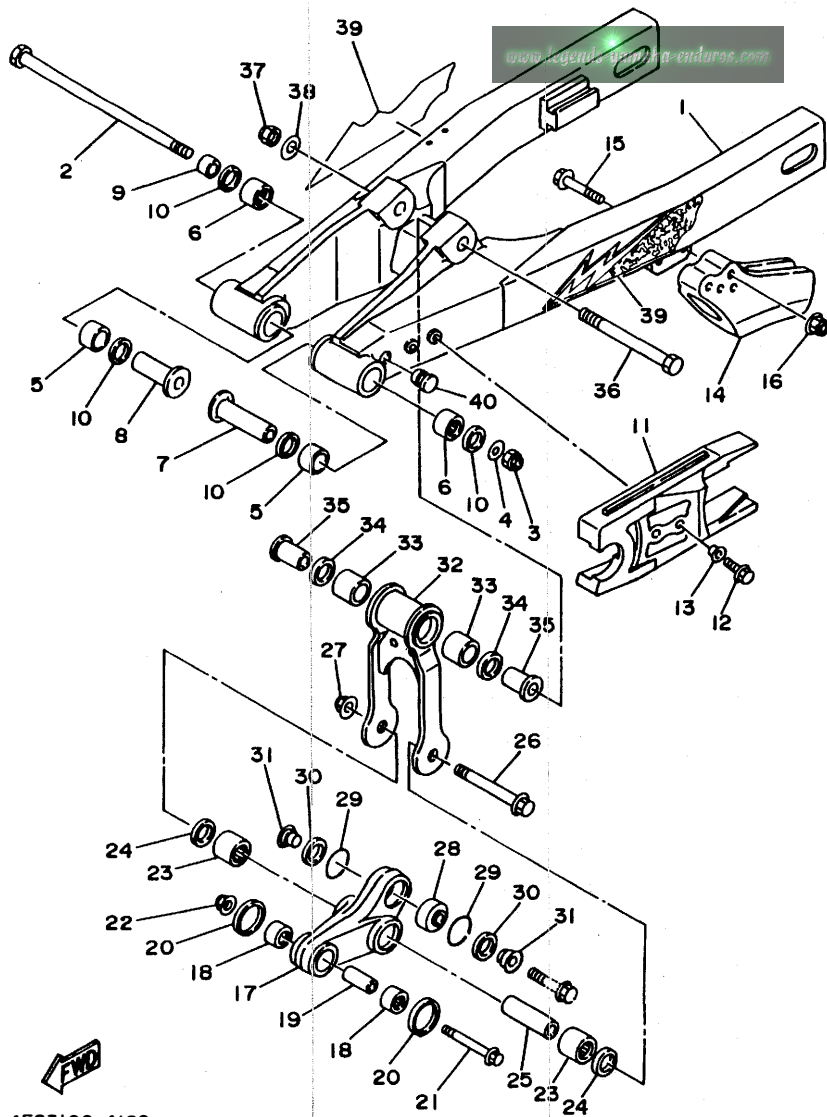


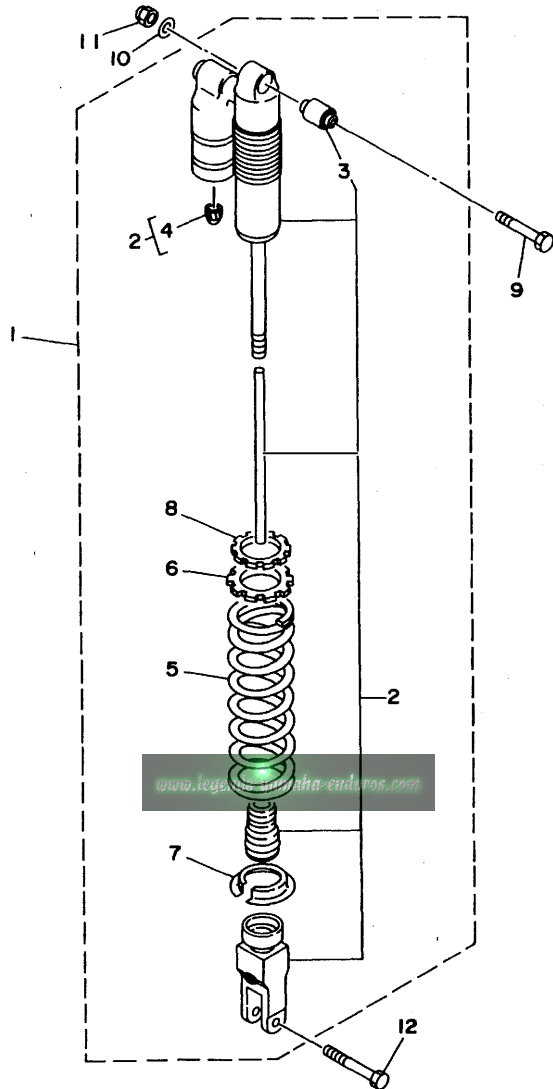
FIG. 18 REAR ARM

REF. NO.	PART NO.	DESCRIPTION	Q'TY	REMARKS
28	93399-99921	BEARING	1	
29	93440-30113	CIRCLIP	2	
30	3XJ-22475-00	SEAL, DUST	2	
31	90387-103X9	COLLAR	2	
32	4ES-2217F-00	ROD, CONNECTING 1	1	
33	93315-31748	BEARING, CYLINDRICAL	2	
34	93101-17062	OIL SEAL	2	
35	90381-12091	BUSH, SOLID	2	
36	90101-12755	BOLT	1	
37	90185-12119	NUT, SELF-LOCKING	1	
38	90201-122A7	WASHER, PLATE	1	
39	4ES-22180-10	EMBLEM	1	
40	90338-10150	PLUG	2	

  
4ES3100-4180



FIG. 19 REAR SUSPENSION

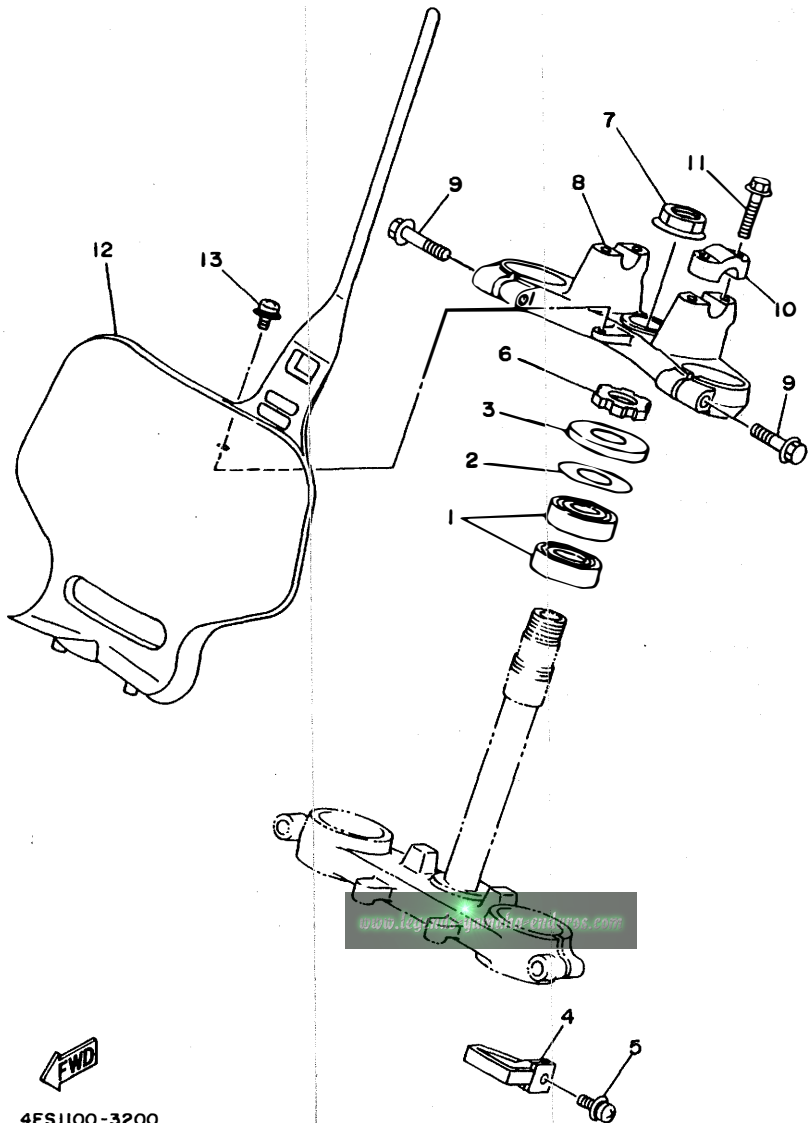


REF. NO.	PART NO.	DESCRIPTION	Q'TY	REMARKS
1	4ES-22210-30	SHOCK ABSORBER ASSY, REAR	1	UR FOR USA
	4ES-22210-40	SHOCK ABSORBER ASSY, REAR	1	UR FOR CANADA
	4ES-22210-50	SHOCK ABSORBER ASSY, REAR	1	UR FOR NEWZEALAND, S.AFRICA
	4LB-22210-00	SHOCK ABSORBER ASSY, REAR	1	UR YZ80LW MODEL
2	4ES-22201-30	.DAMPER SUB ASSY	1	UR FOR USA
	4ES-22201-40	.DAMPER SUB ASSY	1	UR FOR CANADA
	4ES-22201-50	.DAMPER SUB ASSY	1	UR FOR NEWZEALAND, S.AFRICA
	4LB-22201-00	.DAMPER SUB ASSY	1	UR YZ80LW MODEL
3	4ES-22216-00	..BUSH, REAR SHOCK ABSORBER	1	
4	58T-23184-L0	..CAP, AIR VALVE	1	
5	4ES-22212-30	.SPRING (K=5.0)	1	UR
	4ES-22212-50	.SPRING (K=5.2)	1	UR YZ80LW MODEL
6	4ES-22214-00	.GUIDE, SPRING 1	1	
7	3JD-22214-00	.GUIDE, SPRING 1	1	
8	4ES-22251-00	.NUT 1	1	
9	90109-10729	BOLT	1	
10	92990-10600	WASHER, PLATE	1	
11	90185-10120	NUT, SELF-LOCKING	1	
12	90105-10614	BOLT, WASHER BASED	1	

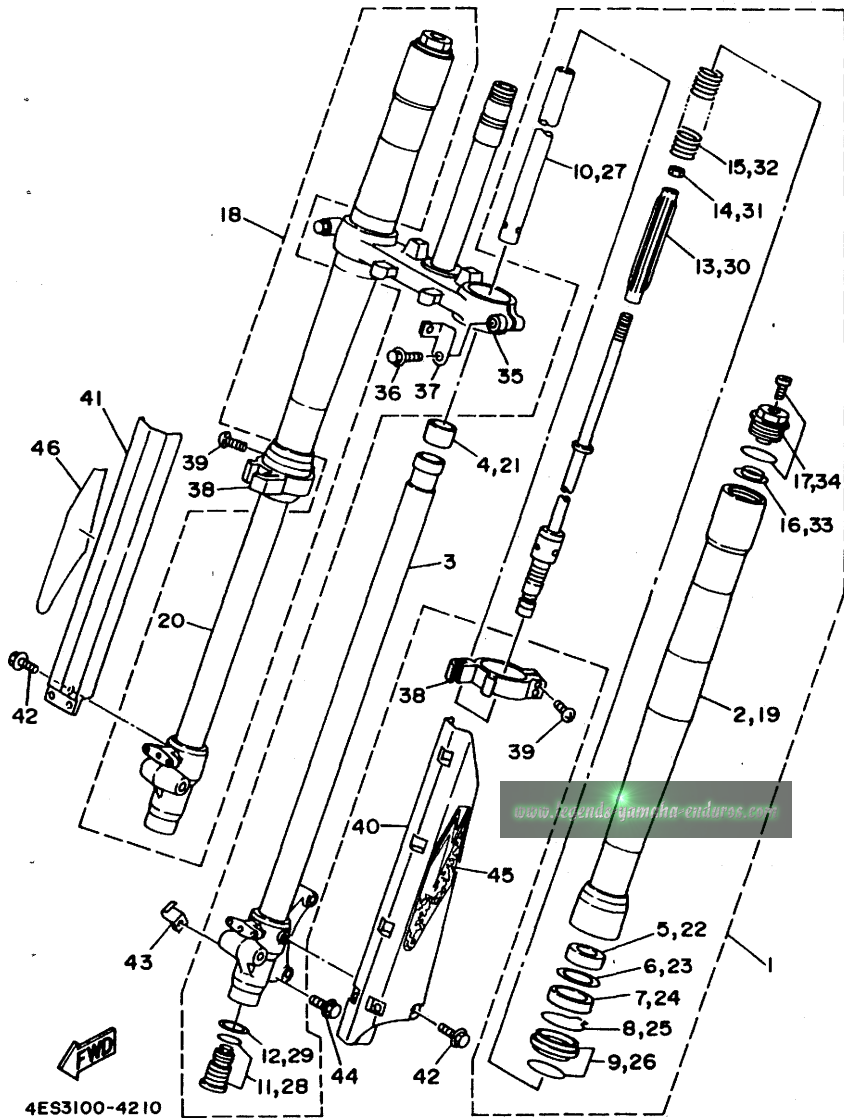
FWD  
4ES1100-3190

FIG. 20 STEERING

REF. NO.	PART NO.	DESCRIPTION	Q'TY	REMARKS
1	93332-00079	BEARING	2	
2	90201-256K5	WASHER, PLATE (0.5T)	1	
3	1J7-23415-00	COVER, BALL RACE 1	1	
4	4DA-23389-00	GUIDE, CABLE	1	
5	90159-05122	SCREW, WITH WASHER	1	
6	90179-25033	NUT	1	
7	90179-22412	NUT	1	
8	4ES-23435-00	CROWN, HANDLE	1	
9	95811-08035	BOLT, FLANGE	2	
10	3SP-23441-00	HOLDER, HANDLE UPPER	2	
11	95023-08030	BOLT	4	
12	4ES-23485-00	PLATE, NUMBER	1	
13	95023-06012	BOLT	1	



4ES1100-3200



4ES3100-4210

FIG. 21 FRONT FORK

REF. NO.	PART NO.	DESCRIPTION	Q'TY	REMARKS
1	4ES-23102-00	FRONT FORK ASSY (L.H)	1	UR
	4LB-23102-00	FRONT FORK ASSY (L.H)	1	UR YZ80LW MODEL
2	4ES-23136-00	.TUBE, OUTER (RIGHT)	1	
3	4ES-23120-00	.INNER TUBE COMP. 2	1	
4	4ES-23171-00	.PISTON, FRONT FORK	1	
5	4ES-23125-00	.METAL, SLIDE 1	1	
6	5K5-23149-00	.WASHER, SPRING UPPER	1	
7	4ES-23145-00	.OIL SEAL	1	
8	4A1-23156-00	.CLIP, OIL SEAL	1	
9	4ES-23144-00	.SEAL, DUST	1	
10	4ES-23170-00	.CYLINDER COMP., FRONT FORK	1	
11	4ES-2316A-00	.VALVE COMP.	1	
12	2HH-23158-L0	.GASKET	1	
13	4ES-23142-00	.SEAT, SPRING UPPER	1	
14	3XJ-23357-L0	.NUT	1	
15	4ES-23141-00	.SPRING, FRONT FORK (K=0.29)	1	UR
	4ES-23141-20	.SPRING, FRONT FORK (K=0.30)	1	UR YZ80LW MODEL
16	3GM-23142-00	.SEAT, SPRING UPPER	1	
17	4ES-23111-00	.BOLT, CAP	1	
18	4ES-23103-00	FRONT FORK ASSY (R.H)	1	UR
	4LB-23103-00	FRONT FORK ASSY (R.H)	1	UR YZ80LW MODEL
19	4ES-23136-00	.TUBE, OUTER (RIGHT)	1	
20	4ES-23110-00	.INNER TUBE COMP. 1	1	
21	4ES-23171-00	.PISTON, FRONT FORK	1	
22	4ES-23125-00	.METAL, SLIDE 1	1	
23	5K5-23149-00	.WASHER, SPRING UPPER	1	
24	4ES-23145-00	.OIL SEAL	1	
25	4A1-23156-00	.CLIP, OIL SEAL	1	

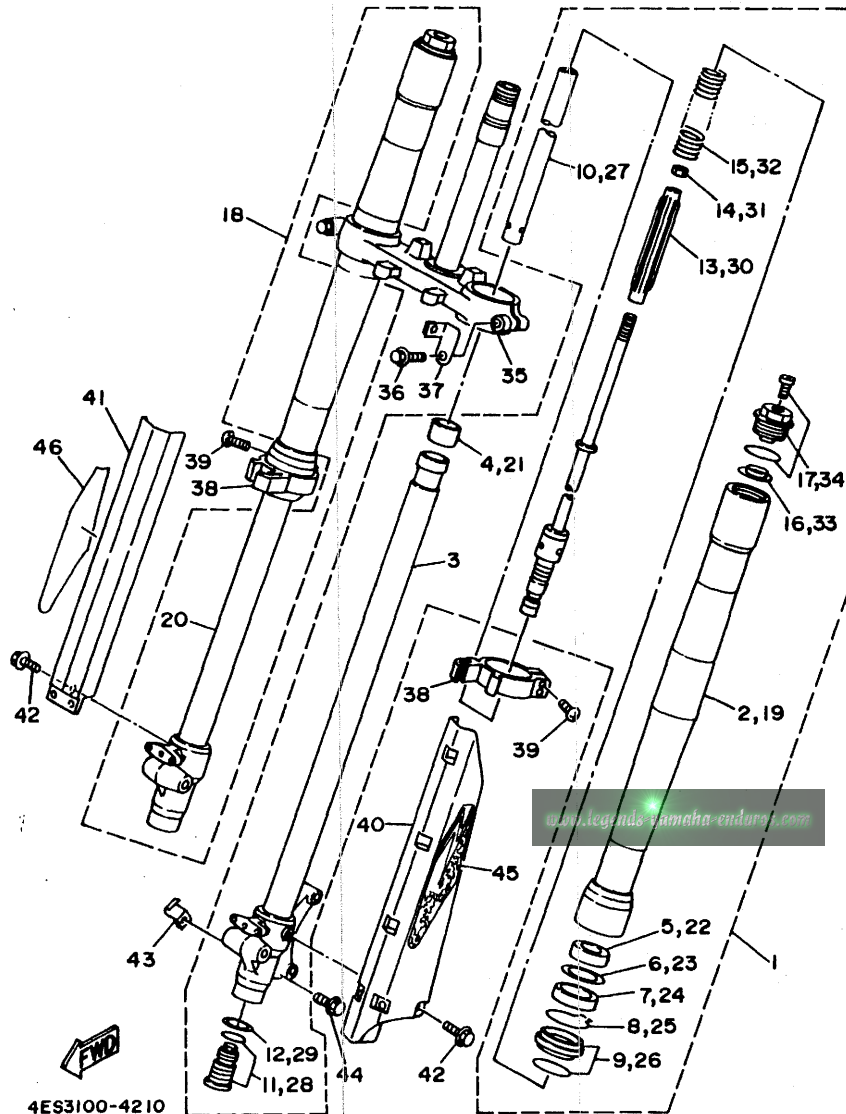
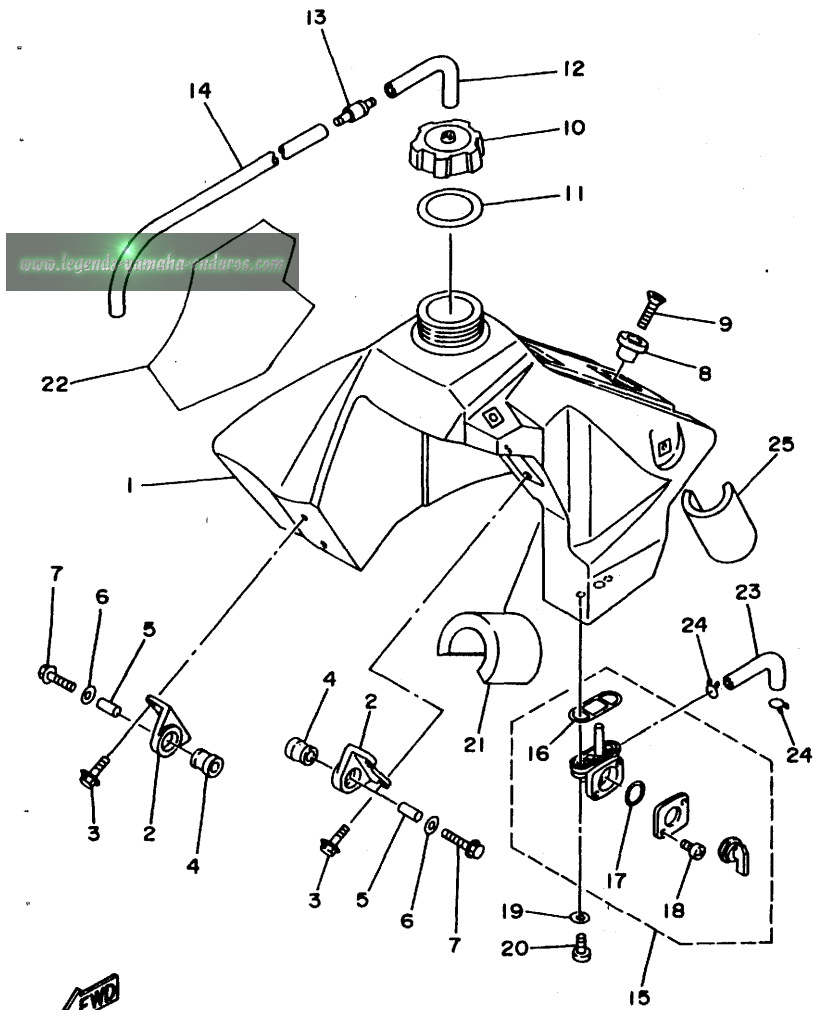


FIG. 21 FRONT FORK

REF. NO.	PART NO.	DESCRIPTION	Q'TY	REMARKS
26	4ES-23144-00	.SEAL, DUST	1	
27	4ES-23170-00	.CYLINDER COMP., FRONT FORK	1	
28	4ES-2316A-00	.VALVE COMP.	1	
29	2HH-23158-LO	.GASKET	1	
30	4ES-23142-00	.SEAT, SPRING UPPER	1	
31	3XJ-23357-LO	.NUT	1	
32	4ES-23141-00	.SPRING, FRONT FORK (K=0.29)	1	UR
	4ES-23141-20	.SPRING, FRONT FORK (K=0.30)	1	UR YZ80LW MODEL
33	3GM-23142-00	.SEAT, SPRING UPPER	1	
34	4ES-23111-00	.BOLT, CAP	1	
35	4ES-23340-00	UNDER BRACKET COMP.	1	
36	95021-10040	BOLT, FLANGE	2	
37	4ES-2331E-00	GUIDE, CABLE	1	
38	4ES-2314F-00	PROTECTOR GUIDE COMP. 1	2	
39	4V4-23194-LO	SCREW, BOOT BAND	4	
40	4ES-2314H-L1	PROTECTOR COMP. 1	1	
41	4ES-2314J-LO	PROTECTOR COMP. 2	1	
42	4DA-23346-LO	BOLT 1	6	
43	4ES-23318-00	HOLDER, CABLE 1	1	
44	95023-06016	BOLT	1	
45	4ES-2313B-10	EMBLEM1	1	
46	4ES-2313C-10	EMBLEM2	1	



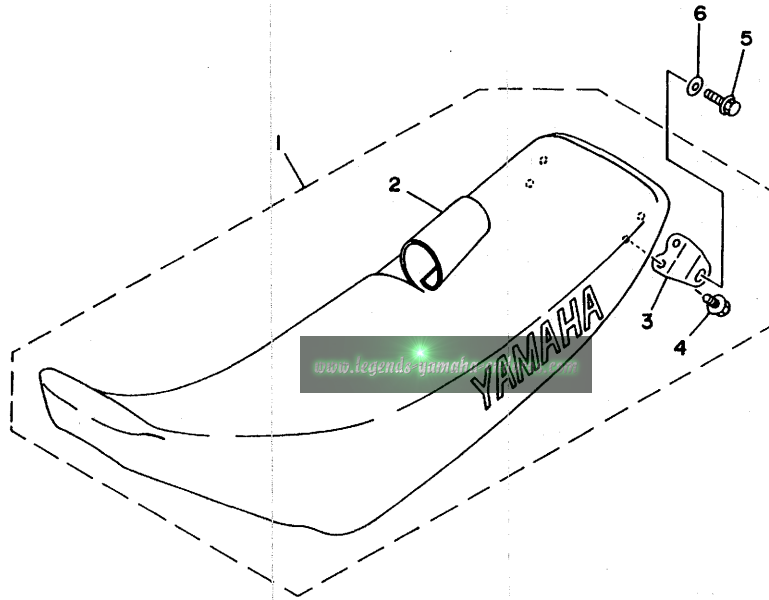
4ES3100-4220

FIG. 22 FUEL TANK

REF. NO.	PART NO.	DESCRIPTION	Q'TY	REMARKS
1	4ES-24110-00	FUEL TANK COMP.	1	
2	24X-24144-00	HOLDER, DAMPER	2	
3	95023-06016	BOLT	4	
4	90480-18549	GROMMET	2	
5	90387-06027	COLLAR	2	
6	90201-06697	WASHER, PLATE	2	
7	95023-06030	BOLT	2	
8	4EW-2412F-00	BRACKET, SEAT	1	
9	98701-06025	SCREW, FLAT HEAD	1	
10	5X7-24611-01	BODY, CAP	1	
11	5X7-24612-00	GASKET, CAP	1	
12	90445-09055	HOSE	1	
13	3XJ-24380-00	PIPE JOINT ASSY	1	
14	90445-09100	HOSE	1	
15	2VN-24500-01	FUEL COCK ASSY 1	1	
16	4X8-24512-00	.O-RING	1	
17	3AJ-24534-00	.SEAL, COCK	1	
18	98580-03008	.SCREW, PAN HEAD	2	
19	90202-05193	WASHER, PLATE	2	
20	90149-06011	SCREW	2	
21	3Y0-24183-00	DAMPER, LOCATING 3	1	
22	4ES-24161-10	EMBLEM 1	1	
23	4ES-24311-00	PIPE, FUEL 1	1	
24	90467-10008	CLIP	2	
25	51L-28371-00	DAMPER	1	

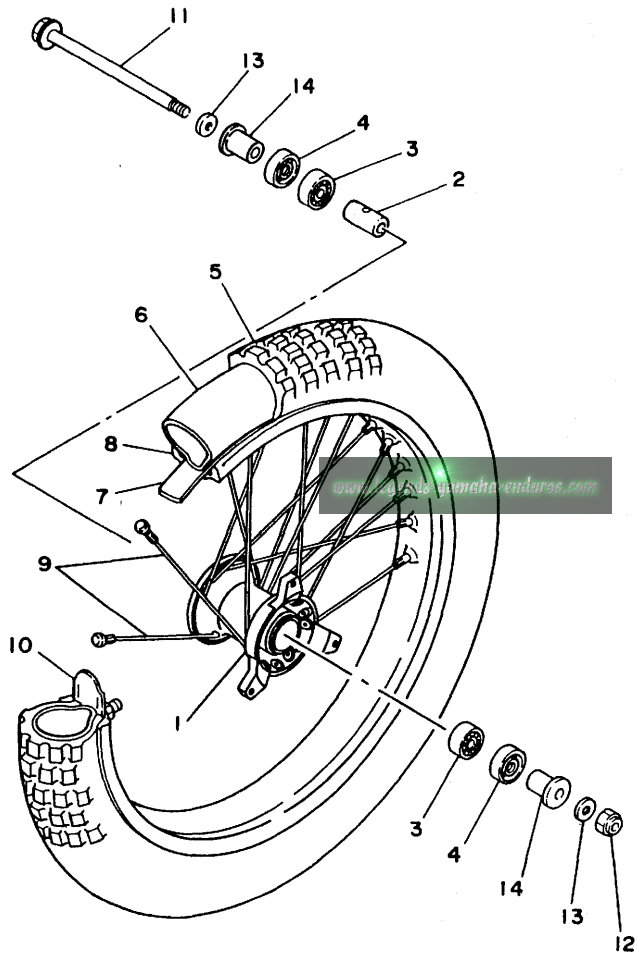
FIG. 23 SEAT

REF. NO.	PART NO.	DESCRIPTION	Q'TY	REMARKS
1	4ES-24770-00	SEMI-DOUBLE SEAT ASSY	1	DEEP VIOLET SOLID 1
2	4ES-24731-00	.COVER, SEAT	1	DEEP VIOLET SOLID 1
3	4ES-24728-00	.BRACKET	2	
4	95023-06012	.BOLT	4	
5	95023-06020	BOLT	2	
6	92901-06200	WASHER, PLAIN	2	



4ES3100-4230

FIG. 24 FRONT WHEEL

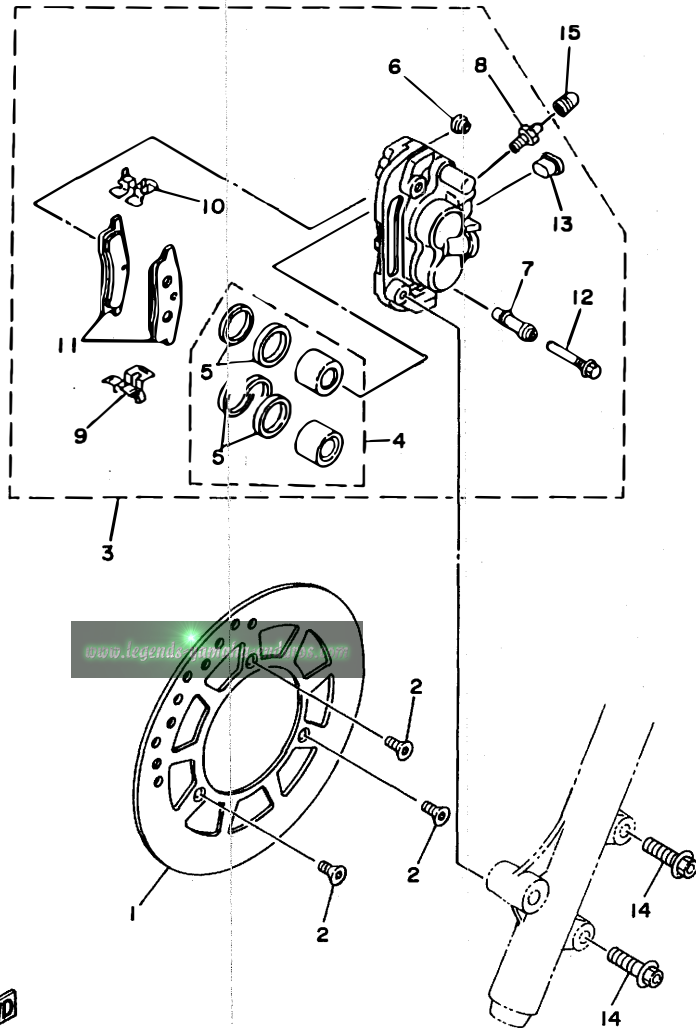


REF. NO.	PART NO.	DESCRIPTION	Q'TY	REMARKS
1	4ES-25111-00	HUB, FRONT	1	
2	90387-124H0	COLLAR	1	
3	93306-20117	BEARING	2	
4	93106-20031	OIL SEAL	2	
5	94107-177Y5	TIRE (70/100-17 40M K490)	1	UR DUNLOP
	94107-1902J	TIRE (70/100-19 42M K990)	1	UR DUNLOP YZ80LW MODEL
6	94207-17284	TUBE (70/100-17 TR4)	1	UR DUNLOP
	94207-19290	TUBE (70/100-19 TR4)	1	UR DUNLOP YZ80LW MODEL
7	94307-17166	BAND, RIM (80/90,70/100-17)	1	UR DUNLOP
	94307-19170	BAND, RIM (70-100-19)	1	UR DUNLOP YZ80LW MODEL
8	94414-17530	RIM (1.40-17)	1	UR
	94414-19521	RIM (1.40-19)	1	UR YZ80LW MODEL
9	4ES-25104-20	SPOKE SET, FRONT	1	UR
	4LB-25104-00	SPOKE SET, FRONT	1	UR YZ80LW MODEL
10	1T1-25194-00	SPACER, BEAD	1	
11	4ES-25181-00	AXLE, WHEEL	1	
12	90185-12046	NUT, SELF-LOCKING	1	
13	90201-12362	WASHER, PLATE	2	
14	4ES-25183-10	COLLAR, WHEEL	2	



4ES1100-3240

FIG. 25 FRONT BRAKE CALIPER



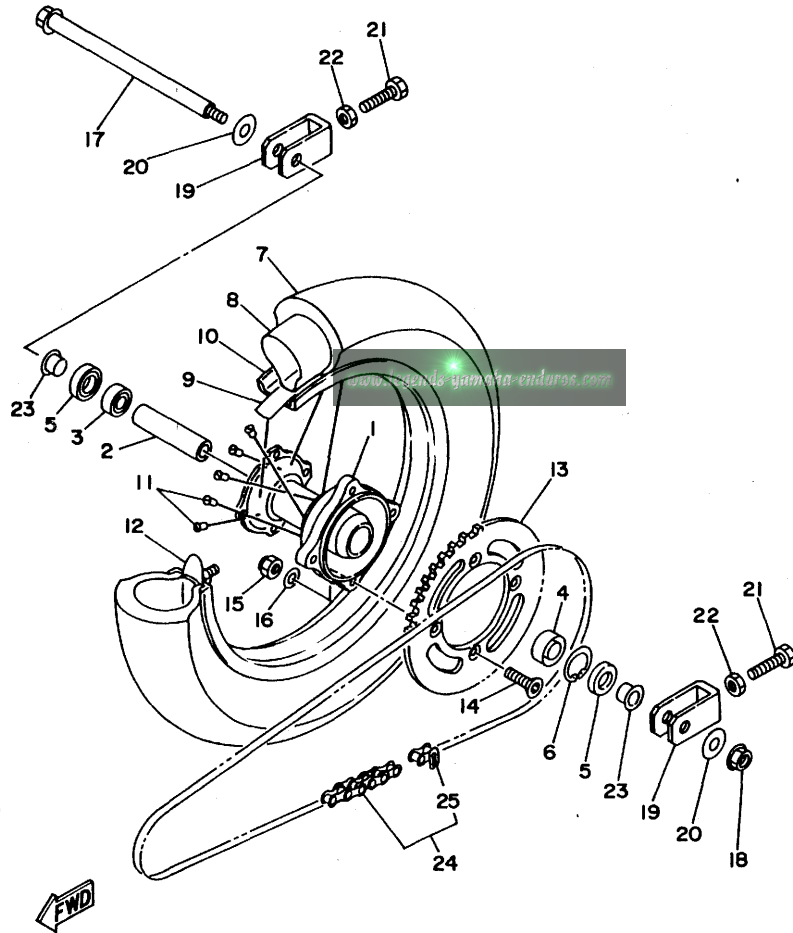
REF. NO.	PART NO.	DESCRIPTION	Q'TY	REMARKS
1	4ES-2582T-00	DISC, BRAKE	1	
2	90149-06272	SCREW	3	
3	4ES-2580T-00	CALIPER ASSY (LEFT)	1	
4	1LR-W0057-00	.PISTON ASSY, CALIPER	1	
5	1LR-W0047-00	..CALIPER SEAL KIT	1	
6	5R2-25937-00	.BOOT 2	1	
7	56A-25937-00	.BOOT 2	1	
8	47X-25824-00	.SCREW, BREED	1	
9	56A-25919-00	.SUPPORT, PAD	1	
10	56A-25919-10	.SUPPORT, PAD	1	
11	4ES-W0045-00	.BRAKE PAD KIT	1	
12	56A-25926-00	.BOLT	1	
13	34X-25845-00	.CAP, INDICATOR	1	
14	90105-08211	BOLT, WASHER BASED	2	
15	51L-25825-00	CAP	1	



4ES3100-4250

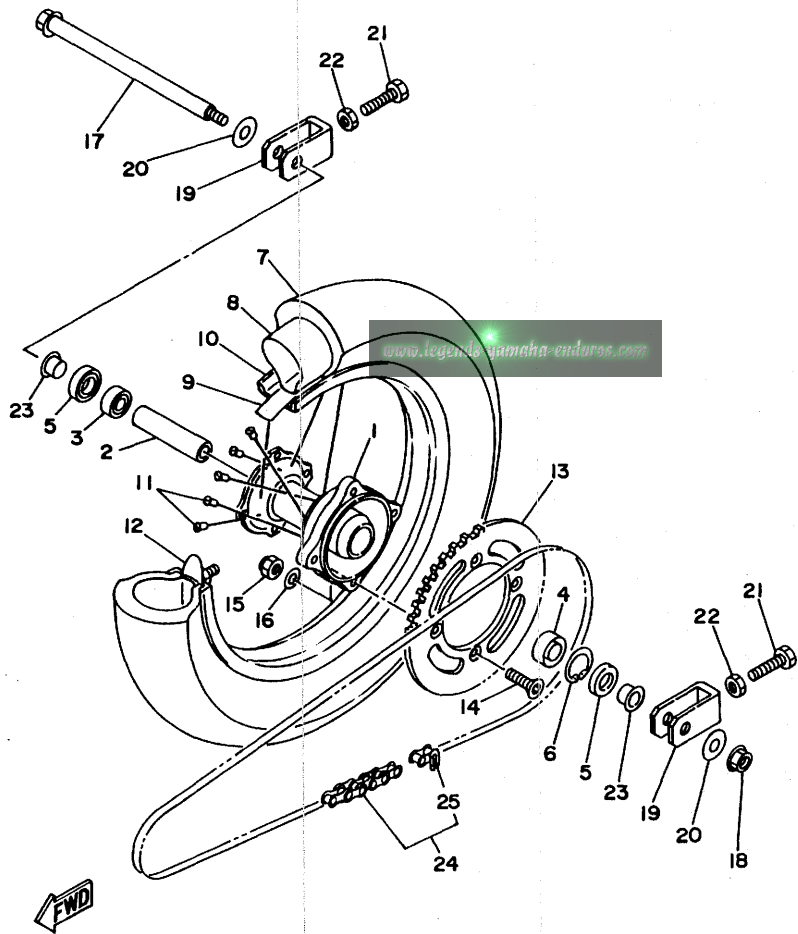


FIG. 26 REAR WHEEL



4ES1100-3260

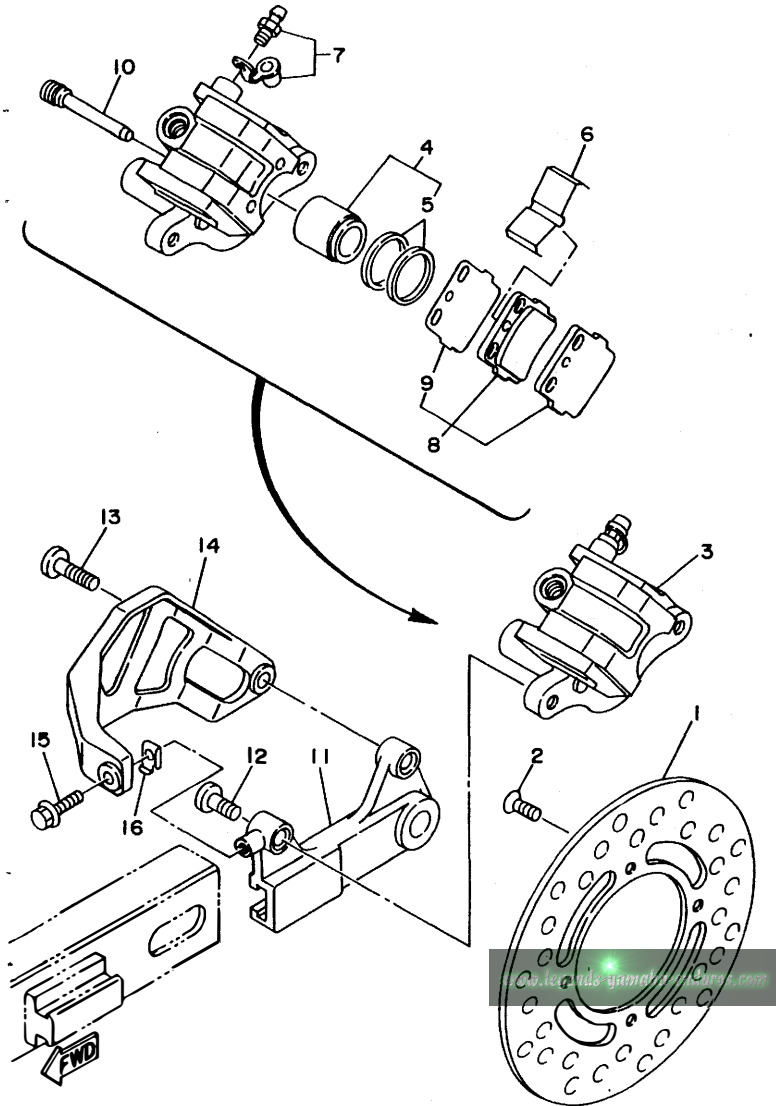
REF. NO.	PART NO.	DESCRIPTION	Q'TY	REMARKS
1	4ES-25311-00	HUB, REAR	1	
2	4ES-25383-00	COLLAR, WHEEL	1	
3	93306-00210	BEARING	1	
4	93306-20204	BEARING (B6202Z)	1	
5	93102-20009	OIL SEAL	2	
6	99009-35500	CIRCLIP	1	
7	94109-147Y6	TIRE (90/100-14 49M K695)	1	UR DUNLOP
	94109-1602K	TIRE (90/100-16 52M K990)	1	UR DUNLOP YZ80LW MODEL
8	94208-14285	TUBE (80-90/100-14 TR4)	1	UR DUNLOP
	94209-16291	TUBE (90/100-16 TR4)	1	UR DUNLOP YZ80LW MODEL
9	94308-14165	BAND, RIM (80-90/100-14)	1	UR DUNLOP
	94307-16171	BAND, RIM (70-90/100-16)	1	UR DUNLOP YZ80LW MODEL
10	94416-14529	RIM (1.60-14)	1	UR
	94418-16522	RIM (1.85-16)	1	UR YZ80LW MODEL
11	4ES-25304-20	SPOKE SET, REAR	1	UR
	4LB-25304-00	SPOKE SET, REAR	1	UR YZ80LW MODEL
12	5X2-25394-00	SPACER, BEAD	1	UR
	1T2-25394-00	SPACER, BEAD	1	UR YZ80LW MODEL
13	4ES-25447-00	SPROCKET, DRIVEN (47T)	1	STD
	4ES-25446-00	SPROCKET, DRIVEN (46T)	1	AP
	4ES-25448-00	SPROCKET, DRIVEN (48T)	1	AP
14	90109-08706	BOLT	4	
15	95611-08100	NUT, U	4	
16	90201-086P8	WASHER, PLATE	4	
17	4ES-25381-01	AXLE, WHEEL	1	
18	95601-14200	NUT, SELF-LOCKING	1	
19	4ES-25388-00	PULLER, CHAIN 1	2	
20	90201-161R1	WASHER, PLATE	2	



4ES1100-3260

FIG. 26 REAR, WHEEL.

REF. NO.	PART NO.	DESCRIPTION	Q'TY	REMARKS
21	90101-08699	BOLT	2	
22	95303-08700	NUT	2	
23	4ES-25383-10	COLLAR, WHEEL	2	
24	94581-58118	CHAIN (DID428G2 118L)	1	UR
	94581-58120	CHAIN (DID428G2 120L)	1	UR YZ80LW MODEL
25	94681-58001	.JOINT, CHAIN (DID 428G2)	1	



4ES1100-3270

FIG. 27 REAR BRAKE CALIPER

REF. NO.	PART NO.	DESCRIPTION	Q'TY	REMARKS
1	4ES-2582W-00	DISC, REAR BRAKE 2	1	
2	90149-06272	SCREW	4	
3	4ES-2580W-00	CALIPER ASSY, REAR 2	1	
4	4ES-W0057-00	.PISTON ASSY, CALIPER	1	
5	4ES-W0047-00	..CALIPER SEAL KIT	1	
6	1UY-25919-51	.SUPPORT, PAD	1	
7	36Y-W0048-00	.BREED SCREW KIT	1	
8	4ES-W0046-50	.BRAKE PAD KIT 2	1	
9	3GD-25827-00	..SHIM, CALIPER	1	
10	3GD-25933-00	.PIN, PAD	2	
11	4ES-25920-00	SUPT. BRKT. ASSY	1	
12	90110-08096	BOLT, HEXAGON SOCKET HEAD	1	
13	90109-08718	BOLT	1	
14	4ES-27491-00	PROTECTOR	1	
15	95023-06012	BOLT	1	
16	4ES-27114-00	STOPPER, MAIN STAND	1	

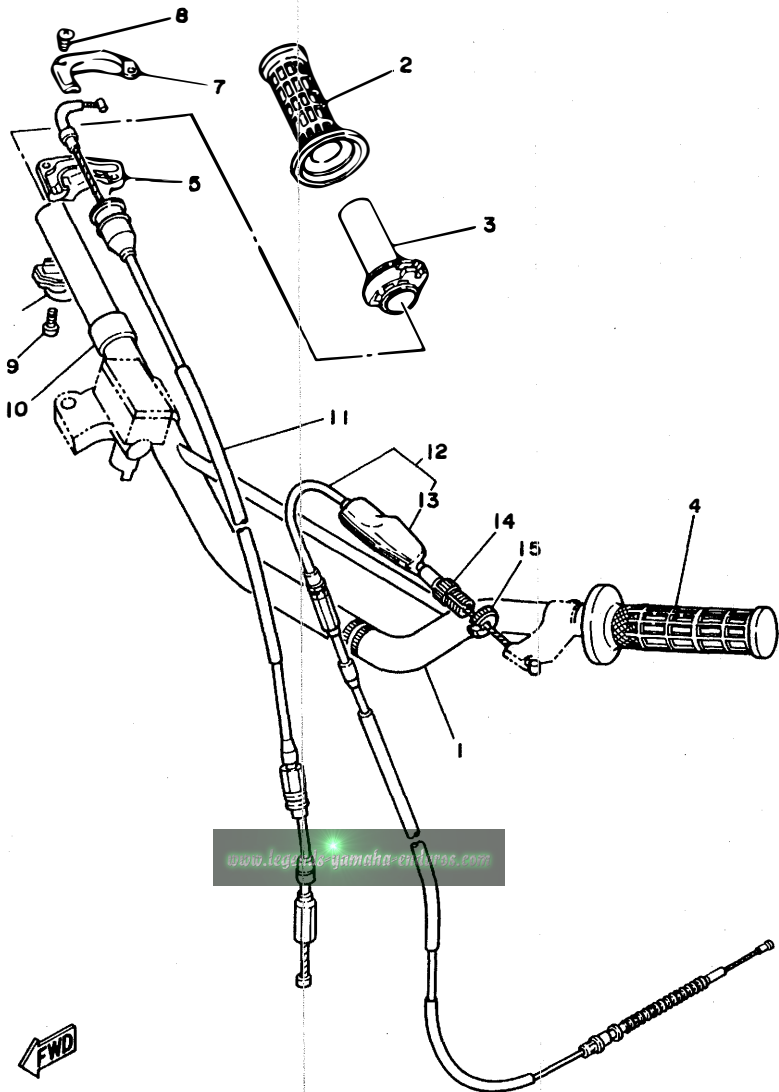


FIG. 28 STEERING HANDLE. CABLE

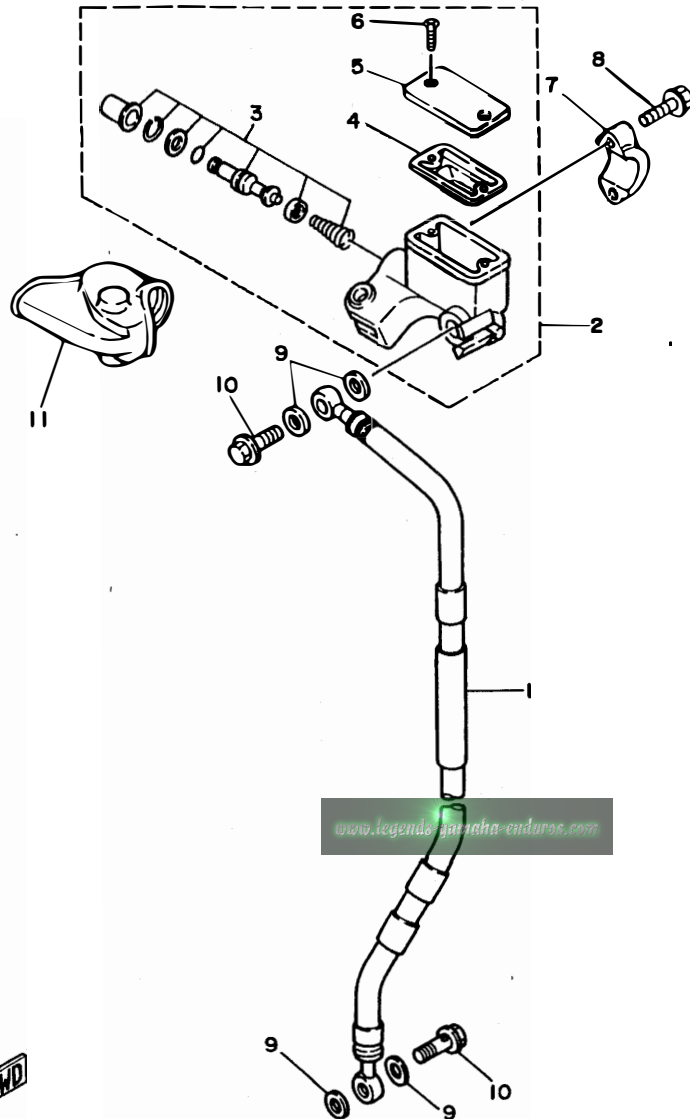
REF. NO.	PART NO.	DESCRIPTION	Q'TY	REMARKS
1	4ES-26111-00	HANDLEBAR	1	
2	1LX-26242-01	GRIP (RIGHT)	1	
3	22W-26243-00	TUBE, THROTTLE GUIDE	1	
4	1LX-26241-01	GRIP (LEFT)	1	
5	5X2-26281-00	CAP, GRIP UPPER	1	
6	322-26282-00	CAP, GRIP LOWER	1	
7	5X2-2628H-01	CAP, WIRE	1	
8	98706-04012	SCREW, FLAT HEAD	2	
9	98586-D5016	SCREW, PAN HEAD	2	
10	90387-22647	COLLAR	1	
11	4ES-26311-00	CABLE, THROTTLE 1	1	
12	4ES-26335-00	CABLE, CLUTCH	1	
13	382-26372-01	COVER, HANDLE LEVER 1	1	
14	90123-08013	BOLT	1	
15	90179-08148	NUT	1	

www.legends-yamaha-en.com



3MK4100-2270

FIG. 29 FRONT MASTER CYLINDER



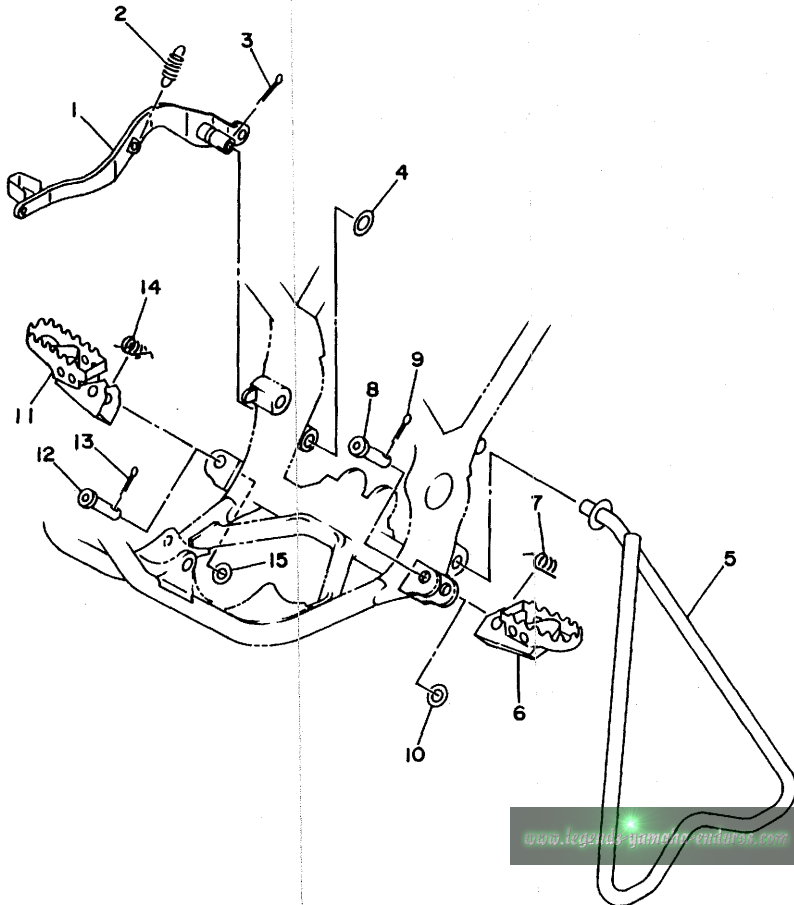
REF. NO.	PART NO.	DESCRIPTION	Q'TY	REMARKS
1	4ES-25872-00	HOSE, BRAKE 1	1	UR
	4LB-25872-00	HOSE, BRAKE 1	1	UR YZ80LW MODEL
2	2VN-25870-01	MASTER CYLINDER SUB ASSY	1	
3	56A-W0041-00	.CYLINDER KIT, MASTER	1	
4	56A-25854-00	.DIAPHRAGM, RESERVOIR	1	
5	2VN-25852-01	.CAP, RESERVOIR	1	
6	98706-04012	.SCREW, FLAT HEAD	2	
7	56A-25867-00	BRACKET, MASTER CYLINDER	1	
8	95026-06025	BOLT, FLANGE	2	
9	90201-10118	WASHER, PLATE	4	
10	90401-10034	BOLT, UNION	2	
11	56A-26372-01	COVER, HANDLE LEVER 1	1	



4ES1100-3290

FIG. 30 STAND. FOOTREST

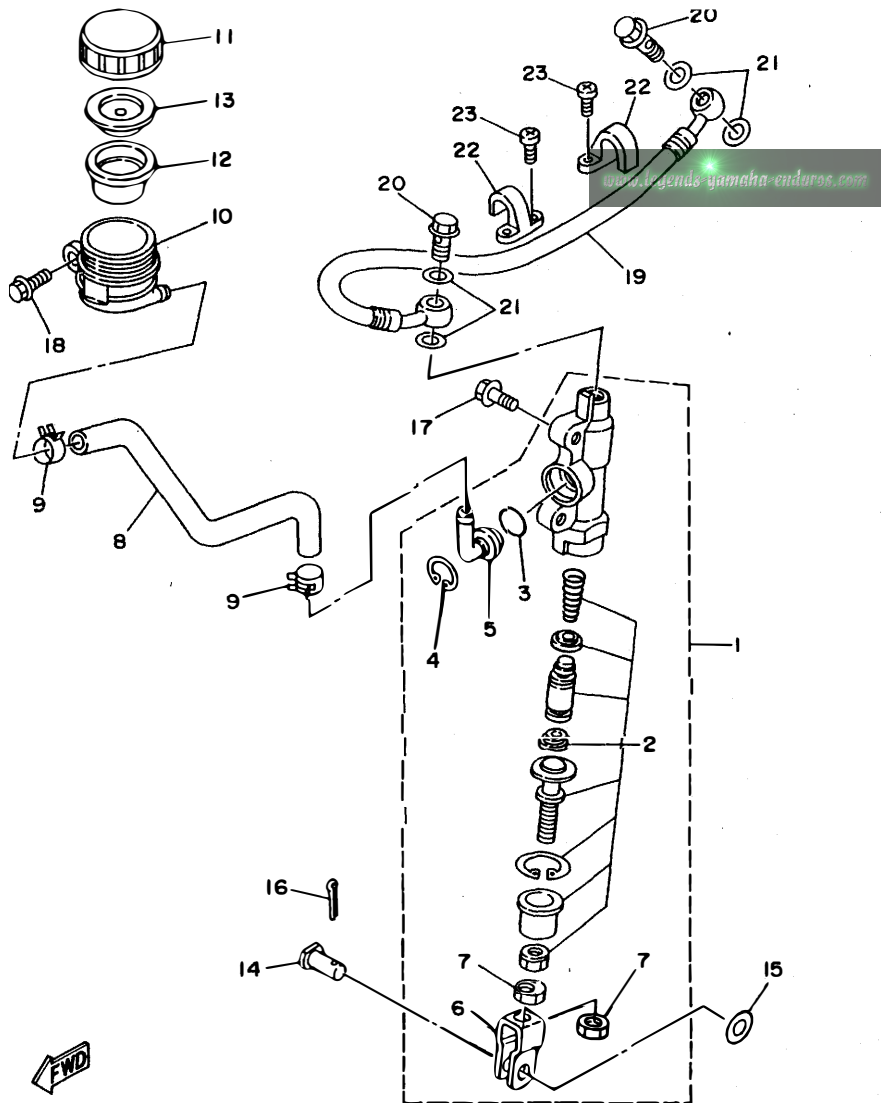
REF. NO.	PART NO.	DESCRIPTION	Q'TY	REMARKS
1	4ES-27211-00	PEDAL, BRAKE	1	
2	90506-15480	SPRING, TENSION	1	
3	91401-20030	PIN, COTTER	1	
4	90201-154E8	WASHER, PLATE	1	
5	4ES-27311-00	STAND, SIDE	1	UR
	4LB-27311-00	STAND, SIDE	1	UR YZ80LW MODEL
6	3SP-27411-00	FOOTREST 1	1	
7	90508-28777	SPRING, TORSION	1	
8	90240-10117	PIN, CLEVIS	1	
9	91401-25020	PIN, COTTER	1	
10	90201-10119	WASHER, PLATE	1	
11	3SP-27421-00	FOOTREST 2	1	
12	90240-10117	PIN, CLEVIS	1	
13	91401-25020	PIN, COTTER	1	
14	90508-28777	SPRING, TORSION	1	
15	90201-10119	WASHER, PLATE	1	



www.legends-games-enduros.com



4ES1100-3300



4ES1100-3310

FIG. 31 REAR MASTER CYLINDER

REF. NO.	PART NO.	DESCRIPTION	Q'TY	REMARKS
1	4ES-2583V-00	RR. MASTER CYLINDER ASSY	1	
2	1FK-W0042-50	.CYLINDER KIT, MASTER	1	
3	93210-15620	.O-RING	1	
4	2VN-25866-00	.CIRCLIP	1	
5	2VN-2582A-50	.JOINT	1	
6	2YK-27222-00	.JOINT	1	
7	95333-08600	.NUT	2	
8	4ES-25895-00	HOSE, RESERVOIR	1	
9	90467-11044	CLIP	2	
10	4EW-25894-00	TANK, RESERVOIR	1	
11	3XP-25852-50	CAP, RESERVOIR	1	
12	2VN-25854-00	DIAPHRAGM, RESERVOIR	1	
13	2VN-25855-00	BUSH,DIAPHRAGM	1	
14	90240-08124	PIN, CLEVIS	1	
15	90201-08083	WASHER, PLATE	1	
16	91401-16020	PIN, COTTER	1	
17	95023-06016	BOLT	2	
18	95023-06012	BOLT	1	
19	4ES-25873-00	HOSE, BRAKE 2	1	UR
	4LB-25873-00	HOSE, BRAKE 2	1	UR YZ80LW MODEL
20	90401-10034	BOLT, UNION	2	
21	90201-10118	WASHER, PLATE	4	
22	2VM-25876-00	HOLDER, BRAKE HOSE 2	2	
23	97780-50110	SCREW, TAPPING	4	

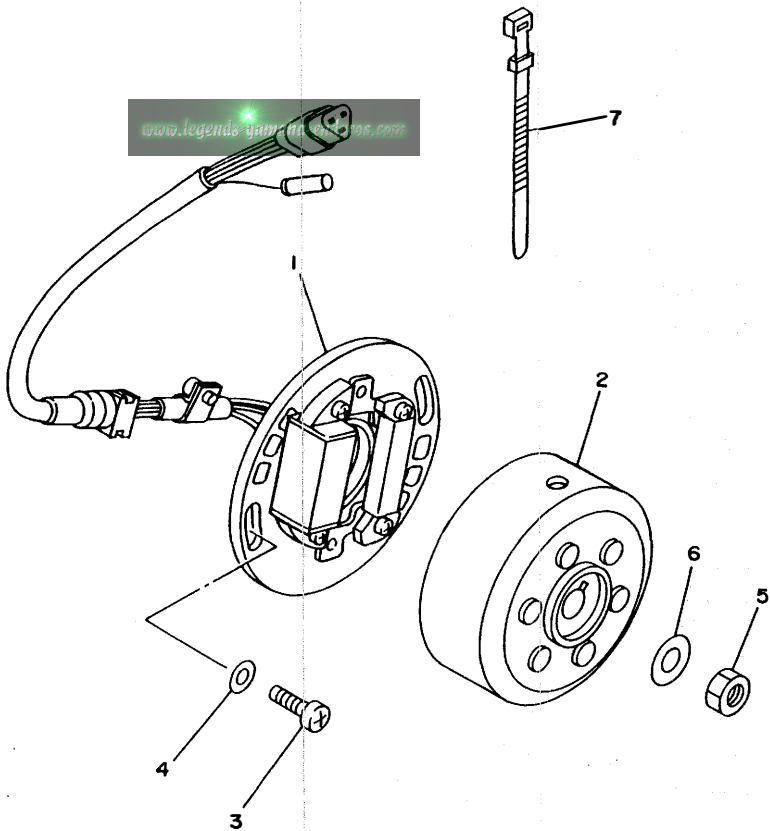


FIG. 32 GENERATOR

REF. NO.	PART NO.	DESCRIPTION	Q'TY	REMARKS
1	4ES-85510-10	STATOR ASSY	1	
2	4ES-85550-00	ROTOR ASSY	1	
3	98502-06016	SCREW, PAN HEAD	2	
4	92901-06600	WASHER, PLATE	2	
5	95311-10600	NUT	1	
6	90201-10774	WASHER, PLATE	1	
7	437-83936-01	BAND, SWITCH CORD	3	



4GT3300-4320



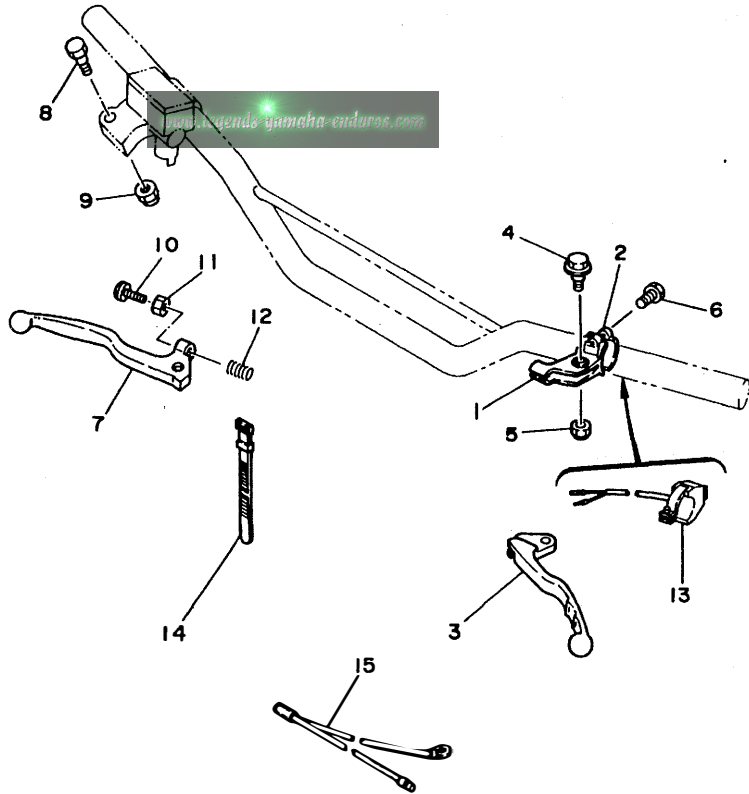


FIG. 33 HANDLE SWITCH. LEVER

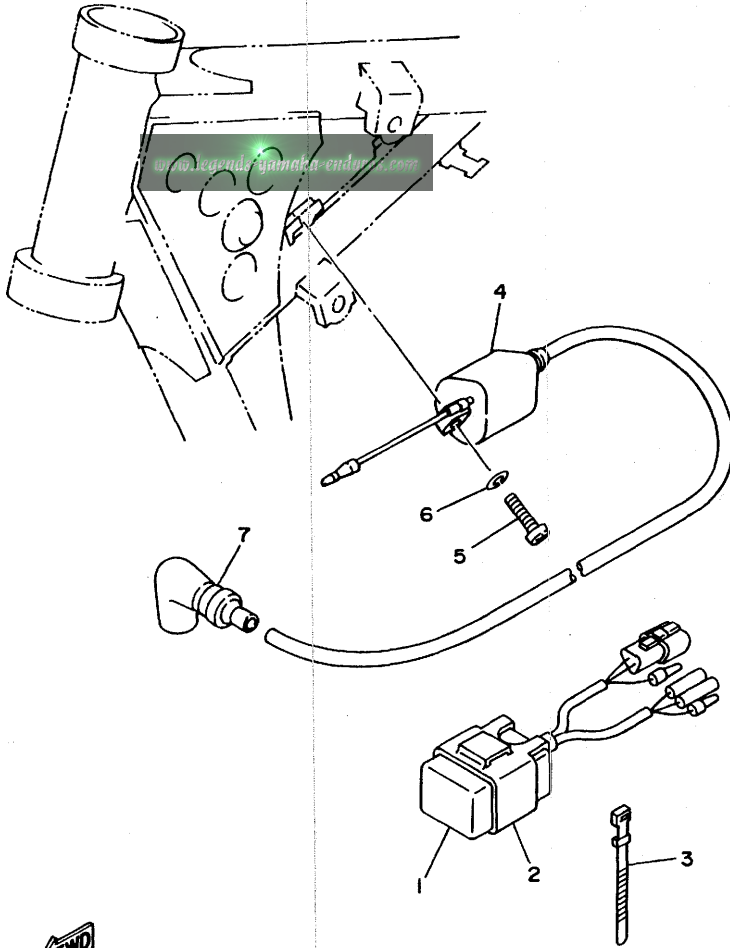
REF. NO.	PART NO.	DESCRIPTION	Q'TY	REMARKS
1	38V-82911-00	HOLDER, LEVER 1	1	
2	38V-82913-00	HOLDER, LEVER LOWER 1	1	
3	23X-83912-00	LEVER 1	1	
4	90109-06799	BOLT	1	
5	95616-06100	NUT, U	1	
6	97006-05016	BOLT	2	
7	55Y-83922-00	LEVER 2	1	
8	90109-06577	BOLT	1	
9	95616-06100	NUT, U	1	
10	90143-06024	SCREW, HEXAGON	1	
11	90170-06010	NUT	1	
12	90501-061G2	SPRING, COMPRESSION	1	
13	23X-83976-00	SWITCH, HANDLE 1	1	
14	437-83936-01	BAND, SWITCH CORD	2	
15	5X1-82519-01	WIRE, EARTH LEAD	1	



4ES1100-3330

FIG. 34 ELECTRICAL 1

REF. NO.	PART NO.	DESCRIPTION	Q'TY	REMARKS
1	4ES-85540-10	C.D.I. UNIT ASSY	1	
2	2A7-85546-00	BAND	1	
3	437-83936-11	BAND, SWITCH CORD	1	
4	43G-82310-40	IGNITION COIL ASSY	1	
5	98580-06020	SCREW, PAN HEAD	2	
6	92995-06100	WASHER	2	
7	81E-82370-20	PLUG CAP ASSY	1	



4ES1100-3340

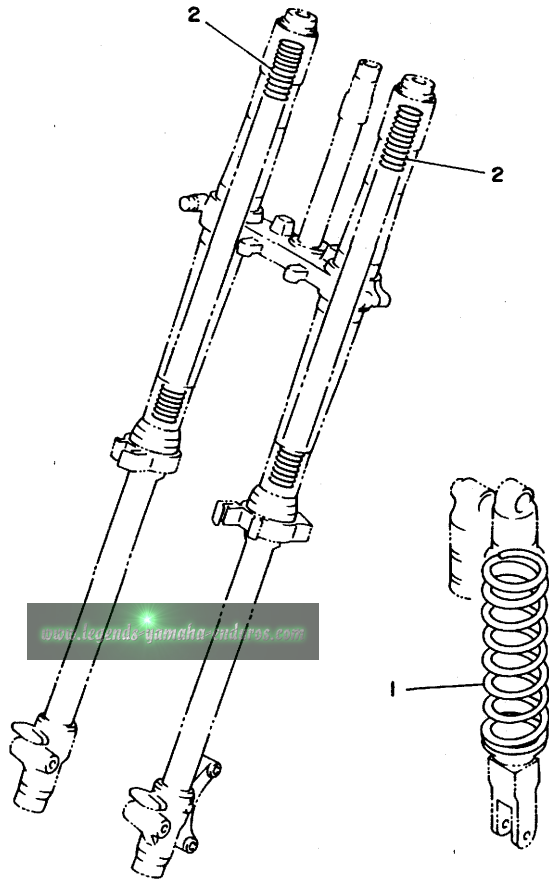


FIG. 35 ALTERNATE (CHASSIS)

REF. NO.	PART NO.	DESCRIPTION	Q'TY	REMARKS
1	4ES-22212-40	SPRING (K=4.8)	1	AP (SOFT)
	4ES-22212-30	SPRING (K=5.0)	1	AP (SOFT) YZ80LW MODEL
	4ES-22212-50	SPRING (K=5.2)	1	AP (HARD)
	4ES-22212-60	SPRING (K=5.4)	1	AP (HARD) YZ80LW MODEL
2	4ES-23141-10	SPRING, FRONT FORK (K=0.28)	2	AP (SOFT)
	4ES-23141-00	SPRING, FRONT FORK (K=0.29)	2	AP (SOFT) YZ80LW MODEL
	4ES-23141-20	SPRING, FRONT FORK (K=0.30)	2	AP (HARD)
	4ES-23141-30	SPRING, FRONT FORK (K=0.31)	2	AP (HARD) YZ80LW MODEL



4ES1100-3350

FIG. 36 REPAIR KIT

REF. NO.	PART NO.	DESCRIPTION	Q'TY	REMARKS
1	4ES-11630-01	PISTON ASSY (STD)	1	
2	4ES-11631-01-BO	.PISTON (STD)	1	
3	43K-11611-00	.RING, PISTON	1	
4	4ES-11633-00	.PIN, PISTON	1	
5	93450-16115	.CIRCLIP	2	
6	4ES-11650-01	CONNECTING ROD ASSY	1	
7	4ES-11651-01	.ROD, CONNECTING	1	
8	93310-320T3	.BEARING, CYLINDRICAL	1	
9	2RA-11681-00	.PIN, CRANK 1	1	
10	90209-20159	.WASHER	2	
11	93310-214F8	.BEARING, CYLINDRICAL	1	KOYO

NUMERICAL INDEX

PART NO.	GRID NO.	PART NO.	GRID NO.	PART NO.	GRID NO.	PART NO.	GRID NO.	PART NO.	GRID NO.	PART NO.	GRID NO.	PART NO.	GRID NO.
56A-W0041-00	D- 7	2X6-14112-25	B- 7	4ES-15651-00	B-12	4ES-21783-10	C- 6	4ES-23141-00	C-11	3XJ-24380-00	C-13		
1FK-W0042-50	D- 9	2X6-14112-30	B- 7	4ES-15660-00	B-12	4ES-22110-00	C- 7		C-12	2VN-24500-01	C-13		
4ES-W0045-00	D- 2	2X6-14112-35	B- 7	4ES-15664-00	B-12	4LB-22110-00	C- 7		D-13	4X8-24512-00	C-13		
4ES-W0046-50	D- 5	3R1-14115-00	B- 7	4ES-16111-00	B-13	4ES-22129-00	C- 7	4ES-23141-10	D-13	3AJ-24534-00	C-13		
1LR-W0047-00	D- 2	2A6-14126-00	B- 8	4ES-16150-00	B-13	4ES-22151-00	C- 7	4ES-23141-20	C-11	5X7-24611-01	C-13		
4ES-W0047-00	D- 5	248-14131-00	B- 7	4V0-16154-00	B-13	4ES-2217A-00	C- 7		C-12	5X7-24612-00	C-13		
36Y-W0048-00	D- 5	3R1-14141-50	B- 7	4ES-16321-00	B-13	4ES-2217F-00	C- 8		D-13	4ES-24728-00	C-14		
1LR-W0057-00	D- 2	3R1-14141-52	B- 7	257-16324-00	B-13	30X-22178-00	C- 4	4ES-23141-30	D-13	4ES-24731-00	C-14		
4ES-W0057-00	D- 5	3R1-14141-54	B- 7	1LR-16351-00	B-13	4ES-22178-00	C- 4	3GM-23142-00	C-11	4ES-24770-00	C-14		
4ES-11111-00	B- 2	260-14142-30	B- 7	4ES-16356-00	B-13	4ES-22180-10	C- 8		C-12	4ES-25104-20	C-15		
4ES-11311-00	B- 2	260-14142-35	B- 7	2X3-16357-00	B-13	4V4-22184-00	C- 4	4ES-23142-00	C-11	4LB-25104-00	C-15		
4ES-11351-00	B- 2	260-14142-40	B- 7	1LR-16371-00	B-13	39K-22199-00	C- 7		C-12	4ES-25111-00	C-15		
4ES-11400-02	B- 3	137-14143-56-A0	B- 7	4ES-16381-00	B-13	4ES-22201-30	C- 9	4ES-23144-00	C-11	22W-25181-01	C- 7		
4ES-11412-00	B- 3	137-14143-58-A1	B- 7	4ES-17121-00	B-14	4ES-22201-40	C- 9		C-12	4ES-25181-00	C-15		
4ES-11422-00	B- 3	137-14143-60-A0	B- 7	4ES-17131-00	B-14	4ES-22201-50	C- 9	4ES-23145-00	C-11	4ES-25183-10	C-15		
43K-11611-00	B- 3	132-14146-00	B- 8	4ES-17151-00	B-14	4LB-22201-00	C- 9		C-11	1T1-25194-00	C-15		
	D-14	39K-14153-00	B- 7	4ES-17161-00	B-14	4ES-22210-30	C- 9	5K5-23149-00	C-11	4ES-25304-20	D- 3		
4ES-11630-01	D-14	2A6-14158-00	B- 8	4ES-17211-01	B-14	4ES-22210-40	C- 9		C-11	4LB-25304-00	D- 3		
4ES-11631-01-A0	B- 3	3X3-14169-00	B- 7	4ES-17221-00	B-14	4ES-22210-50	C- 9	4A1-23156-00	C-11	4ES-25311-00	D- 3		
4ES-11631-01-B0	B- 3	3S8-14171-00	B- 8	4ES-17231-00	B-14	4LB-22210-00	C- 9		C-11	4ES-25381-01	D- 3		
	D-14	304-14184-00	B- 7	4ES-17241-00	B-14	4ES-22212-30	C- 9	2HH-23158-L0	C-11	4ES-25383-00	D- 3		
4ES-11631-01-C0	B- 3	314-14185-00	B- 7	4ES-17251-00	B-14		D-13		C-12	4ES-25383-10	D- 4		
4ES-11631-01-D0	B- 3	127-14186-00	B- 7	4ES-17261-00	B-14	4ES-22212-40	D-13	4ES-2316A-00	C-11	4ES-25388-00	D- 3		
4ES-11633-00	B- 3	55X-14196-00	B- 8	4ES-17411-00	B-14	4ES-22212-50	C- 9		C-12	1T2-25394-00	D- 3		
	D-14	278-14197-00	B- 7	4ES-17421-00	B-14		D-13	4ES-23170-00	C-11	5X2-25394-00	D- 3		
4ES-11650-01	D-14	4ES-14411-00	B- 6	164-17427-00-P06	B-14	4ES-22212-60	D-13		C-12	4ES-25446-00	D- 3		
4ES-11651-01	B- 3	4ES-14451-00	B- 6	4ES-18101-00	C- 3	3JD-22214-00	C- 9	4ES-23171-00	C-11	4ES-25447-00	D- 3		
	D-14	4ES-14453-00	B- 6	2HF-18110-01	C- 3	4ES-22214-00	C- 9		C-11	4ES-25448-00	D- 3		
2RA-11681-00	B- 3	4ES-14458-00	B- 6	4BA-18140-00	C- 3	4ES-22216-00	C- 9	58T-23184-L0	C- 9	4ES-25807-00	D- 2		
	D-14	4ES-14459-00	B- 6	4ES-18511-00	C- 2	4ES-22251-00	C- 9	4V4-23194-L0	C-12	4ES-25804-00	D- 5		
4BA-12422-00	B- 4	4ES-14462-00	B- 6	4V0-18512-00	C- 2	3XJ-22475-00	C- 8	4ES-2331E-00	C-12	2VN-2582A-50	D- 9		
4BA-12428-00	B- 4	4ES-14610-00	B- 9	4ES-18513-00	C- 2	4ES-23102-00	C-11	4ES-23318-00	C-12	4ES-2582T-00	D- 2		
36F-12450-00	B- 4	17W-14615-00	B- 9	4BA-18531-00	C- 2	4LB-23102-00	C-11	4ES-23340-00	C-12	4ES-2582W-00	D- 5		
4ES-12459-00	B- 4	4ES-1469A-00	B- 9	4BA-18535-00	C- 2	4ES-23103-00	C-11	4DA-23346-L0	C-12	47X-25824-00	D- 2		
4ES-12461-00	B- 5	4ES-14753-00	B- 9	4ES-18540-00	C- 2	4LB-23103-00	C-11	3XJ-23357-L0	C-11	51L-25825-00	D- 2		
22W-12462-00	B- 5	565-14771-00	B- 9	4ES-21110-01-P0	C- 4	4ES-23110-00	C-11		C-12	3GD-25827-00	D- 5		
22W-12463-00	B- 5	58T-1490J-00	B- 7	4ES-21511-00	C- 5	4ES-23111-00	C-11	4DA-23389-00	C-10	4ES-2583V-00	D- 9		
4ES-12481-00	B- 5	4ES-15111-00	B-10	4ES-21611-00	C- 5		C-12	1J7-23415-00	C-10	34X-25845-00	D- 2		
4ES-12482-00	B- 5	4ES-15121-01	B-10	4ES-21642-00	C- 5	4ES-23120-00	C-11	4ES-23435-00	C-10	2VN-25852-01	D- 7		
4ES-13565-00	B- 6	1RG-15363-00	B-11	4ES-21711-00	C- 6	4ES-23125-00	C-11	3SP-23441-00	C-10	3XP-25852-50	D- 9		
4ES-13610-00	B- 6	583-15371-00	B-10	4EW-2172A-00	C- 6		C-11	4ES-23485-00	C-10	2VN-25854-00	D- 9		
4ES-13613-00	B- 6	4ES-15411-00	B-11	4ES-21721-00	C- 6	4ES-2313B-10	C-12	4ES-24110-00	C-13	56A-25854-00	D- 7		
4ES-13616-00	B- 6	4ES-15421-00	B-11	4ES-2173E-00	C- 6	4ES-2313C-10	C-12	4EW-2412F-00	C-13	2VN-25855-00	D- 9		
4ES-14101-01	B- 7	4ES-15451-00	B-11	4ES-2173F-00	C- 6	4ES-23136-00	C-11	24X-24144-00	C-13	2VN-25866-00	D- 9		
31J-14103-00	B- 7	4ES-15461-00	B-11	4ES-21731-00	C- 6		C-11	4ES-24161-10	C-13	56A-25867-00	D- 7		
10W-14104-00	B- 8	4ES-15620-00	B-12	4ES-21732-00	C- 6	4ES-2314F-00	C-12	22W-24181-00	C- 6	2VN-25870-01	D- 7		
22W-14106-00	B- 7	4ES-15621-00	B-12	4ES-21735-00	C- 6	4ES-2314H-L1	C-12	3Y0-24183-00	C-13	4ES-25872-00	D- 7		
23L-14107-25	B- 7	4ES-15641-00	B-12	4DJ-2174A-00	C- 6	4ES-2314J-L0	C-12	4ES-24311-00	C-13	4LB-25872-00	D- 7		

NUMERICAL INDEX

PART NO.	GRID NO.	PART NO.	GRID NO.	PART NO.	GRID NO.	PART NO.	GRID NO.	PART NO.	GRID NO.	PART NO.	GRID NO.
4ES-25873-00	D- 9	4ES-85550-00	D-10	90201-06067	B- 5	90387-06363	B- 9	92901-06600	D-10	93440-30113	C- 8
4LB-25873-00	D- 9	90101-08699	D- 4	90201-065F3	B-12	90387-064X4	C- 5	92902-04100	B- 7	93450-16115	B- 3
2YM-25876-00	D- 9	90101-12755	C- 8		B-14	90387-0700G	B- 5	92990-03100	B- 6		D-14
4EW-25894-00	D- 9	90105-08211	D- 2	90201-06697	C-13	90387-103X9	C- 8	92990-10600	C- 9	93503-16010	B-13
4ES-25895-00	D- 9	90105-08310	C- 7	90201-08083	D- 9	90387-105L0	B- 9	92995-06100	B- 6	93507-32031	B-12
1UY-25919-51	D- 5	90105-10582	C- 7	90201-08087	B- 2	90387-1200U	C- 7		D-12	93603-22028	B- 4
56A-25919-00	D- 2	90105-10614	C- 9		B-11	90387-124H0	C-15	93101-12060	C- 3	93822-12012	B-14
56A-25919-10	D- 2	90105-12382	C- 7	90201-081R9	C- 4	90387-126Y7	C- 3	93101-17062	C- 7	93822-13024	B-14
4ES-25920-00	D- 5	90109-06577	D-11	90201-08512	8- 4	90387-127J7	C- 7		C- 8	93822-14037	B-14
56A-25926-00	D- 2	90109-067F4	C- 6	90201-086P8	D- 3	90387-127J8	C- 7	93102-12224	B-13	93822-15065	B-14
3GD-25933-00	D- 5	90109-06799	D-11	90201-10118	D- 7	90387-20488	B-13	93102-17263	B-12	94107-177Y5	C-15
5R2-25937-00	D- 2	90109-08706	D- 3		D- 9	90387-22647	D- 6	93102-20009	D- 3	94107-1902J	C-15
56A-25937-00	D- 2	90109-08718	D- 5	90201-10119	D- 8	90401-10034	D- 7	93102-20143	B-14	94109-147Y6	D- 3
4ES-26111-00	D- 6	90109-10729	C- 9		D- 8		D- 9	93102-20447	B- 3	94109-1602K	D- 3
1LX-26241-01	D- 6	90110-08096	D- 5	90201-10774	D-10	90430-06166	B- 4	93103-10168	B- 4	94207-17284	C-15
1LX-26242-01	D- 6	90116-08318	B- 2	90201-122A7	C- 8	90445-09055	C-13	93103-28126	B- 3	94207-19290	C-15
22W-26243-00	D- 6	90116-08388	B- 2	90201-12362	C-15	90445-09100	C-13	93106-20031	C-15	94208-14285	D- 3
5X2-2628H-01	D- 6	90116-08394	B- 2	90201-124F8	B-12	90446-07349	B-10	93109-17048	C- 7	94209-16291	D- 3
5X2-26281-00	D- 6	90119-06063	C- 5	90201-12469	C- 7	90450-28014	B- 5	93210-15620	D- 9	94307-16171	D- 3
322-26282-00	D- 6	90119-06118	C- 4	90201-12631	B-12	90450-99064	B- 6	93210-18288	B- 7	94307-17166	C-15
4ES-26311-00	D- 6	90119-06185	C- 5	90201-154E8	D- 8	90460-43053	B- 6	93210-19123	B-11	94307-19170	C-15
4ES-26335-00	D- 6	90119-06217	C- 6	90201-161R1	D- 3	90460-51059	B- 6	93210-371A9	B- 9	94308-14165	D- 3
382-26372-01	D- 6		C- 6	90201-176L4	B-12	90467-08004	B- 5	93210-56459	B- 2	94414-17530	C-15
56A-26372-01	D- 7	90122-06034	B- 6	90201-203E7	B-14	90467-10008	C-13	93210-84724	B- 2	94414-19521	C-15
4ES-27114-00	D- 5	90123-08013	D- 6	90201-256K5	C-10	90467-11044	D- 9	93306-00210	D- 3	94416-14529	D- 3
4ES-27211-00	D- 8	90143-06024	D-11	90201-33299	B- 9	90468-23194	B-12	93306-20117	C-15	94418-16522	D- 3
2YK-27222-00	D- 9	90149-06011	C-13	90202-05193	C-13	90480-15528	B- 5	93306-20204	D- 3	94580-24118	D- 4
4ES-27311-00	D- 8	90149-06272	D- 2	90208-12015	B-13	90480-16561	B- 9	93306-20333	B-14	94581-58118	D- 4
4LB-27311-00	D- 8		D- 5		B-13	90480-18411	B- 9	93306-20421	B-14	94680-24001	D- 4
35P-27411-00	D- 8	90157-06071	B-14	90209-06096	B- 6	90480-18549	C-13	93306-20468	B- 3	94681-58001	D- 4
35P-27421-00	D- 8	90159-05011	B-13	90209-06187	C- 5	90501-06162	D-11	93306-30421	B- 3	94702-00367	B- 2
4ES-27491-00	D- 5	90159-05122	C-10	90209-20159	B- 3	90501-12081	B-12	93310-214F8	B- 3	94702-00368	B- 2
51L-28371-00	C-13	90167-05031	B- 6		D-14	90501-20361	B-13		D-14	95021-06014	C- 7
43G-82310-40	D-12	90170-06010	D-11	90240-08124	D- 9	90506-15480	D- 8	93310-320T3	B- 3	95021-08080	B-11
81E-82370-20	D-12	90176-08026	B- 2	90240-10117	D- 8	90507-20030	B- 9		D-14	95021-10040	C-12
5X1-82519-01	D-11	90179-08148	D- 6		D- 8	90508-242A6	C- 3	93315-11206	B-13	95023-06012	B- 9
38V-82911-00	D-11	90179-08491	B- 2	90250-06013	C- 2	90508-26750	B-12	93315-31449	C- 7		B-12
38V-82913-00	D-11	90179-12244	B-13	90280-03017	B- 3	90508-28777	D- 8	93315-31502	B-14		C-10
23X-83912-00	D-11		B-13	90282-05001	B-13		D- 8	93315-31748	C- 7		C-14
55Y-83922-00	D-11	90179-22412	C-10	90338-10150	C- 8	90508-32553	C- 3		C- 8		D- 5
437-83936-01	B- 5	90179-25033	C-10	90380-10218	C- 7	91011-08125	C- 4	93317-11245	B-14		D- 9
	D-10	90183-06023	C- 6	90380-12219	C- 7	91011-08135	C- 4	93317-21746	C- 7	95023-06016	C- 5
	D-11	90183-06069	C- 6	90381-12091	C- 8	91401-16020	D- 9	93332-00079	C-10		C- 6
437-83936-11	D-12	90185-10120	C- 9	90385-17042	C- 7	91401-20030	D- 8	93399-99921	C- 8		C-12
23X-83976-00	D-11	90185-12046	C-15	90387-06027	C-13	91401-25020	D- 8	93410-20038	B-14		C-13
4ES-85510-10	D-10	90185-12119	C- 7	90387-062M9	C- 6		D- 8	93430-08007	B-12		D- 9
4ES-85540-10	D-12		C- 8	90387-062X0	C- 7	92580-06560	B-10	93440-15012	B-14	95023-06020	B- 6
2A7-85546-00	D-12	90201-060A3	B- 9	90387-06216	C- 4	92901-06200	C-14	93440-17064	B-14		C-14

NUMERICAL INDEX

PART NO.	GRID NO.	PART NO.	GRID NO.	PART NO.	GRID NO.	PART NO.	GRID NO.	PART NO.	GRID NO.
95023-06025	B- 4								
	B- 9								
	B- 9								
95023-06030	B- 5								
	B-11								
	C-13								
95023-06040	B-11								
95023-08012	C- 4								
95023-08030	C-10								
95026-06025	D- 7								
95303-08700	D- 4								
95311-10600	D-10								
95333-08600	D- 9								
95601-08200	C- 4								
	C- 7								
95601-10200	C- 7								
95601-12200	C- 7								
95601-14200	D- 3								
95611-08100	D- 3								
95616-06100	D-11								
	D-11								
95811-08035	C-10								
95821-06060	B- 4								
97006-05016	D-11								
97011-06020	C- 3								
97780-50110	D- 9								
98502-06016	D-10								
98511-04016	B- 7								
98580-03008	B- 6								
	C-13								
98580-06020	D-12								
98580-06030	B-11								
98580-06040	B-10								
98580-06550	B-10								
98586-05016	D- 6								
98701-06025	C-13								
98706-04012	D- 6								
	D- 7								
99006-10600	C- 3								
99009-10400	C- 2								
99009-12400	B-12								
99009-18400	B-15								
99009-35500	D- 3								
99080-07600	B- 4								
99510-10114	B- 2								
99530-10014	B-10								
	B-11								

