



YAMAHA

GENUINE

PARTS CATALOGUE

MOTORCYCLE

www.legends-yamaha-enduros.com

CYLINDER HEAD-CYLINDER

Ref. No.	Part Number	Description	Qty	Remarks
1	2A7-11111-00-00	HEAD, CYLINDER 1	1	
2	2A7-11311-00-00	CYLINDER 1	1	
3	90116-08104-00	BOLT, STUD	6	
4	90116-06016-00	BOLT, STUD	2	
5	2A6-11129-00-00	ABSORBER 5	1	
6	1W2-11181-00-00	GASKET, CYLINDER HEAD 1 .	1	
7	90201-08100-00	WASHER, PLATE	6	
8	95333-08600-00	NUT	6	
9	18G-11351-01-00	GASKET, CYLINDER	1	
10	95611-10630-00	BOLT, STUD	2	
11	95611-10640-00	BOLT, STUD	2	
12	99530-14016-00	PIN, DOWEL	2	
13	90179-10201-00	NUT	4	
14	NGK-B8ES0-00-00	PLUG, SPARK (NGK B8ES) ...	1	

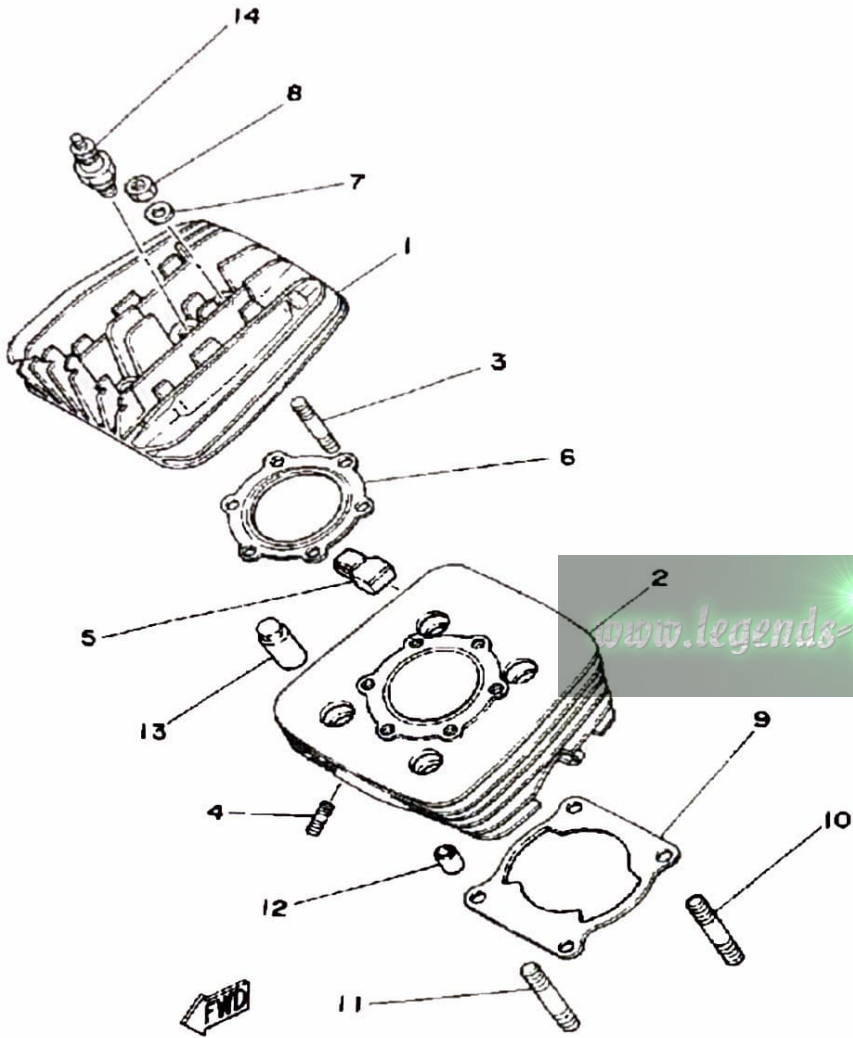

CRANKSHAFT-PISTON

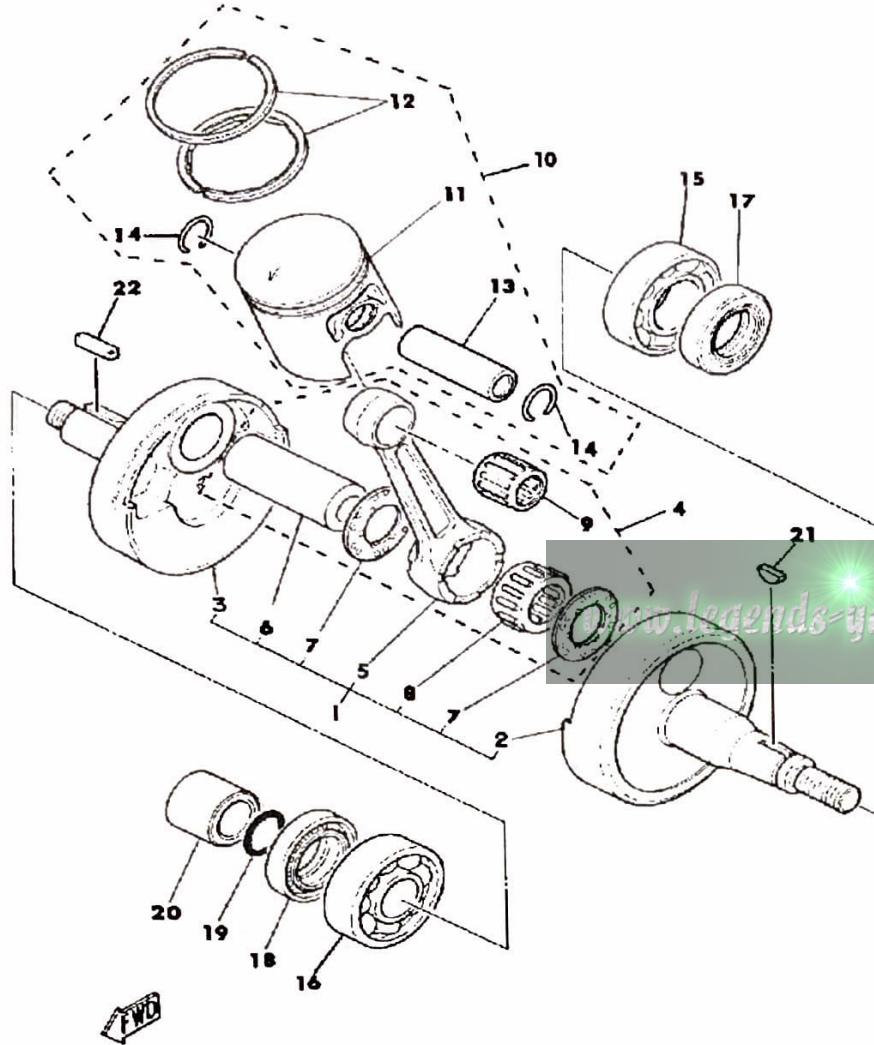

Ref. No.	Part Number	Description	Qty	Remarks
1	2N4-11400-00-00	CRANKSHAFT ASSEMBLY ...	1	
2	1W1-11412-01-00	. CRANK 1	1	
3	1W1-11422-01-00	. CRANK 2	1	
4	(3U5-11650-00-00)	CONNECTING ROD ASSEMBLY	1	ASSEMBLY
5	25V-11651-00-00	.. ROD, CONNECTING 1	1	
6	3M5-11681-00-00	.. PIN, CRANK 1	1	
7	90209-22248-00	.. WASHER	2	
8	93310-42277-00	.. BEARING, CYLINDER.#10 (93310-42231)	1	
9	93310-216E1-00	. BEARING	1	
10	2N5-11630-00-00	PISTON KIT STD	1	ASSEMBLY
11	2N5-11631-00-96	. PISTON STD (2A7-11631-00-96)	1	
12	2N5-11610-00-00	. PISTON RINGSET STD	1	
13	251-11633-00-00	. PIN, PISTON	1	
14	93450-17044-00	. CIRCLIP	2	
15	93306-20529-00	BEARING (B6205C4)	1	
16	93306-30421-00	BEARING (B6304C3)	1	
17	93102-25061-00	OIL SEAL, SD-TYPE	1	
18	93103-28011-00	OIL SEAL	1	
19	93210-180A6-00	O-RING	1	
20	90387-20488-00	COLLAR	1	
21	2N5-11610-10-00	PISTON RINGSET 1ST	1	
	2N5-11610-20-00	PISTON RINGSET 2ND	1	
	2N5-11610-30-00	PISTON RINGSET 3RD	1	
	2N5-11610-40-00	PISTON RINGSET 4TH	1	
	2N5-11630-10-00	PISTON KIT 1ST	1	
	2N5-11630-20-00	PISTON KIT 2ND	1	
	2N5-11630-30-00	PISTON KIT 3RD	1	

CONTINUED ON NEXT FRAME ►

CRANKSHAFT-PISTON

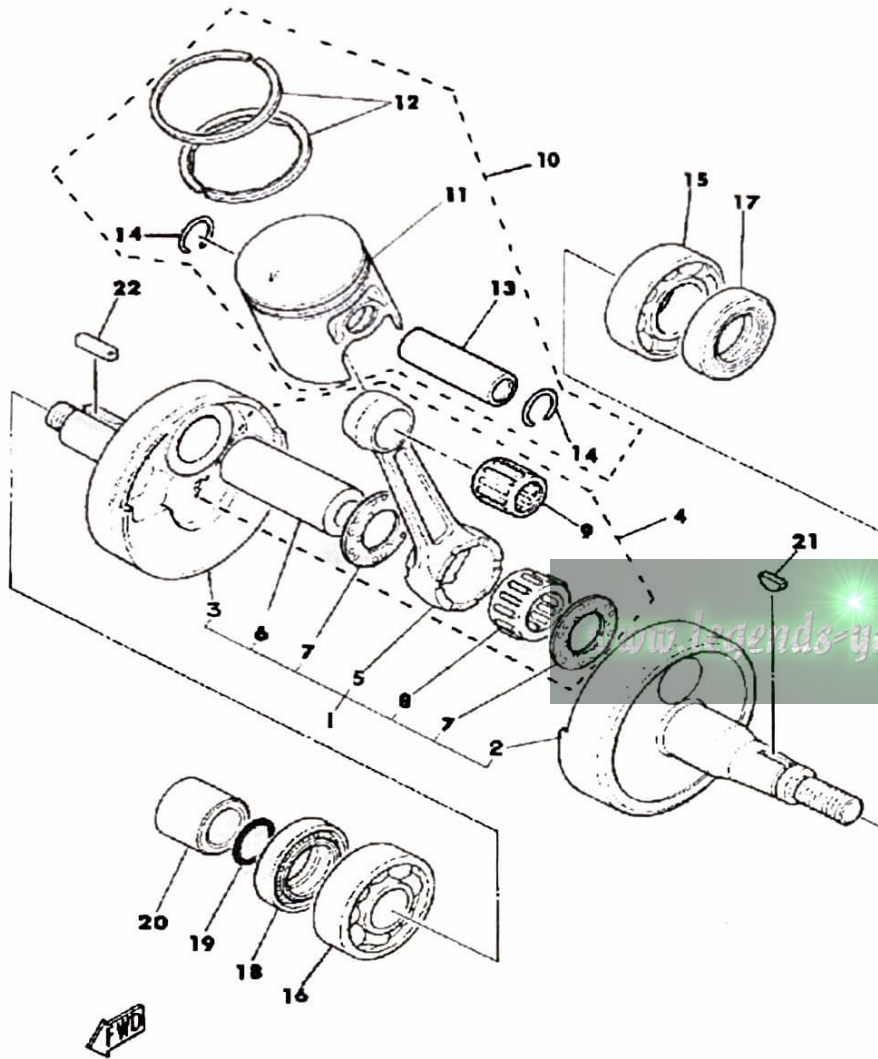

Ref. No.	Part Number	Description	Qty	Remarks
21	2N5-11630-40-00	PISTON KIT 4TH	1	
	2N5-11635-00-00	PISTON 1 O/S 0.25 (2A7-11635-00)	1	
	2N5-11636-00-00	PISTON 2 O/S 0.50 (2A7-11636-00)	1	
	2N5-11637-00-00	PISTON 3 O/S 0.75 (2A7-11637-00)	1	
	2N5-11638-00-00	PISTON 4 O/S 1.00 (2A7-11638-00)	1	
	90280-03017-00	KEY, WOODRUFF	1	
	90282-05005-00	KEY, STRAIGHT	1	

C - D - I - MAGNETO

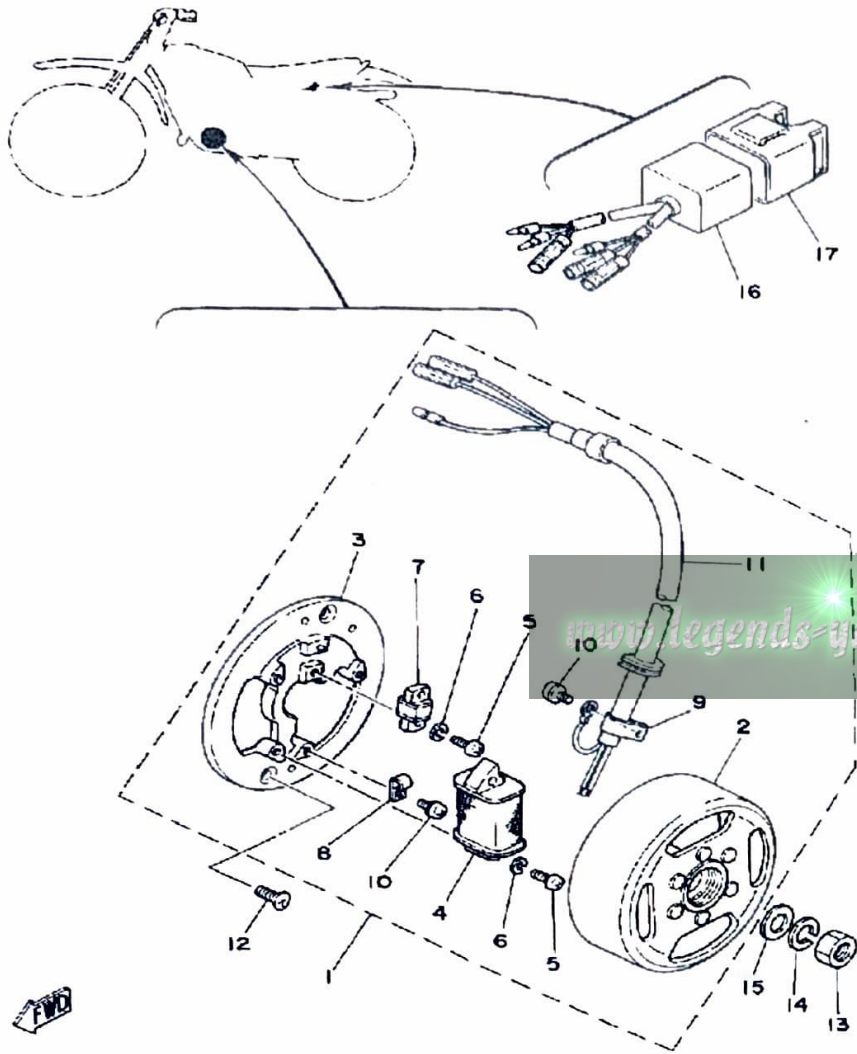

Ref. No.	Part Number	Description	Qty	Remarks
1	3M2-85500-90-00	C D I MAGNETO ASSEMBLY.	1	
2	3M2-85550-20-00	. ROTOR ASSEMBLY	1	
3	3M2-85509-21-00	. BASE, MAGNETO	1	
4	3M2-85512-20-00	. COIL, SOURCE	1	
5	98503-04014-00	. SCREW, PAN HEAD	3	
6	92901-04100-00	. WASHER, SPRING	3	
7	3M2-85580-20-00	. COIL, PULSER	1	
8	(445-85528-20-00)	CLAMP, LEAD	1	
9	104-81328-20-00	. CLAMP	1	
10	97601-04106-00	. SCREW, PN/HD.W/WSHR	2	
11	3M2-85515-20-00	. LEAD WIRE ASSEMBLY	1	
12	98603-06012-00	SCREW, OVAL HEAD (92701-06012)	2	
13	90170-12347-00	NUT, HEXAGON	1	
14	90201-12593-00	WASHER, PLATE	1	
15	92901-12100-00	WASHER, SPRING	1	
16	3M2-85540-20-00	CDI UNIT ASSEMBLY	1	
17	2A7-85546-00-00	BAND	1	

OIL PUMP

Ref. No.	Part Number	Description	Qty	Remarks
1	2A6-13101-00-00	OIL PUMP ASSEMBLY	1	
2	402-13552-00-00	. NOZZLE	1	
3	93505-32002-00	. BALL	1	
4	90501-02018-00	. SPRING, COMPRESSION	1	
5	90430-04004-00	. GASKET	1	
6	98901-04008-00	. SCREW, BIND	1	
7	137-13138-01-00	. PLATE, ADJUSTING	1	
8	137-13137-00-03	. SHIM (0.3T)	1	U.R.
	137-13137-00-05	. SHIM (0.5T)	1	U.R.
	137-13137-00-10	. SHIM (1.0T)	1	U.R.
9	92990-05100-00	. WASHER, SPRING	1	
10	95380-05600-00	. NUT	1	
11	275-13175-01-00	SHAFT, WORM	1	
12	90201-08624-00	WASHER, PLATE	1	
13	3MT-13116-00-00	GASKET, PUMP CASE (8Y0-13116-00)	1	
14	98530-05016-00	SCREW, PAN HEAD	2	
15	93101-10002-00	OIL SEAL	1	
16	1E7-13176-00-00	METAL, WRM SHAF OTR	1	
17	2A6-13178-00-00	GEAR, PUMP DRIVE	1	
18	93603-22028-00	PIN, DOWEL	1	
19	99001-08600-00	CIRCLIP	1	
20	363-13133-01-00	CLIP	1	
21	92901-08600-00	WASHER	1	
22	93210-07100-00	O-RING	1	
23	90468-08086-00	CLIP	1	
24	2A6-13115-01-00	CONNECTOR, SCTN PPE	1	
25	90445-07219-00	HOSE	1	
26	90445-09100-00	HOSE	1	

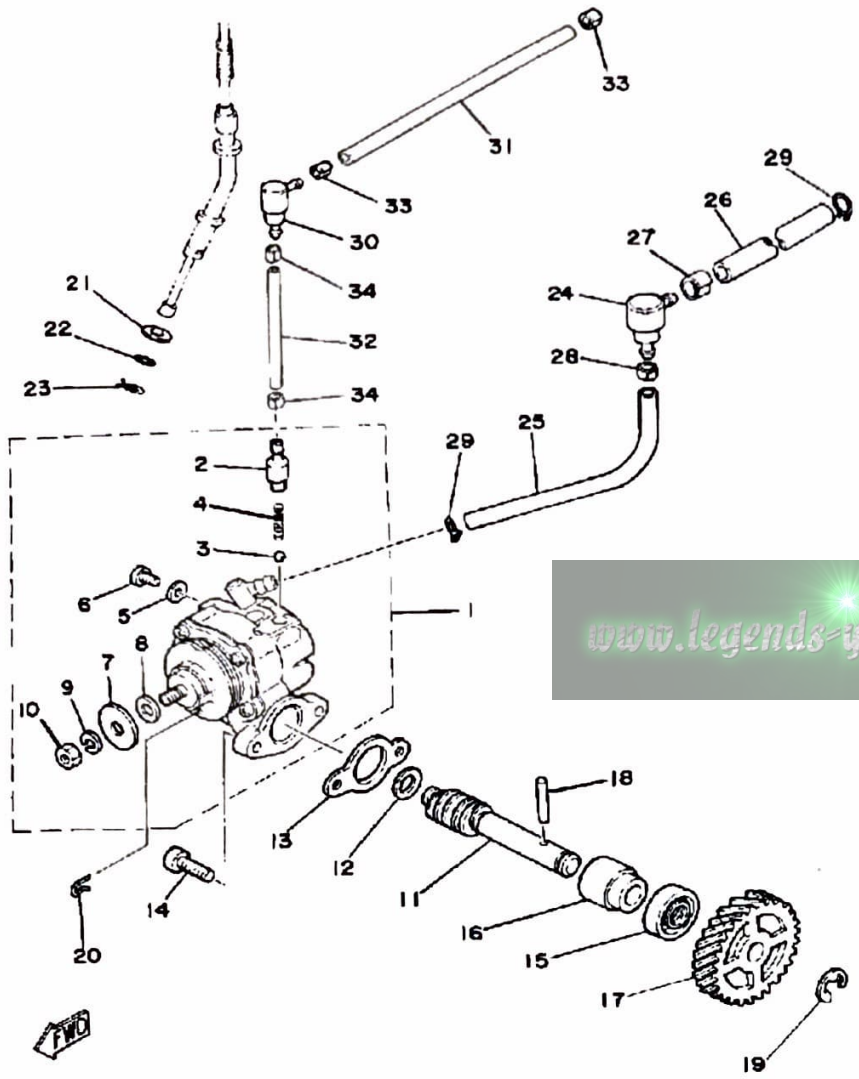

CONTINUED ON NEXT FRAME ►

OIL PUMP

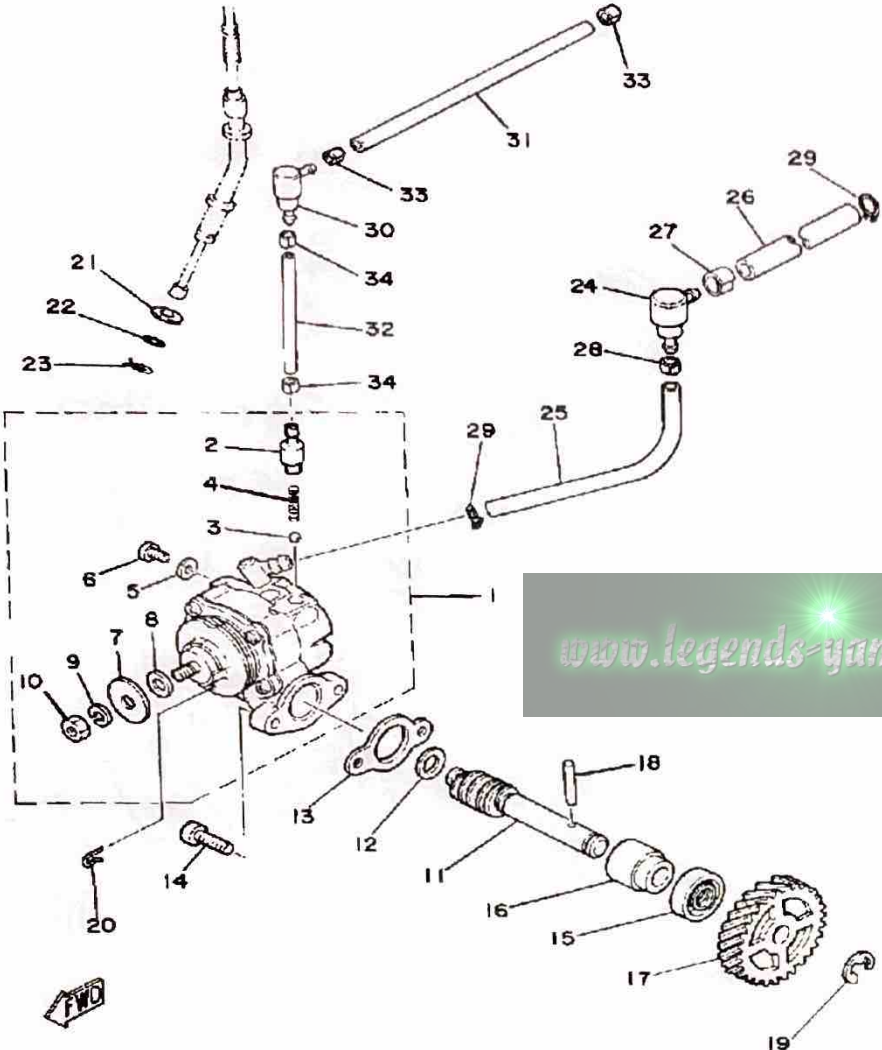

Ref. No.	Part Number	Description	Qty	Remarks
27	90468-02078-00	CLIP	1	
28	90468-02025-00	CLIP	1	
29	90467-08003-00	CLIP	2	
30	2A6-13164-01-00	CONCT, DELIVERY PPE	1	
31	90445-05024-00	HOSE (835-13171-00)	1	
32	90445-05019-00	HOSE	1	
33	90468-02033-00	CLIP	2	
34	90468-02033-00	CLIP	2	

INTAKE

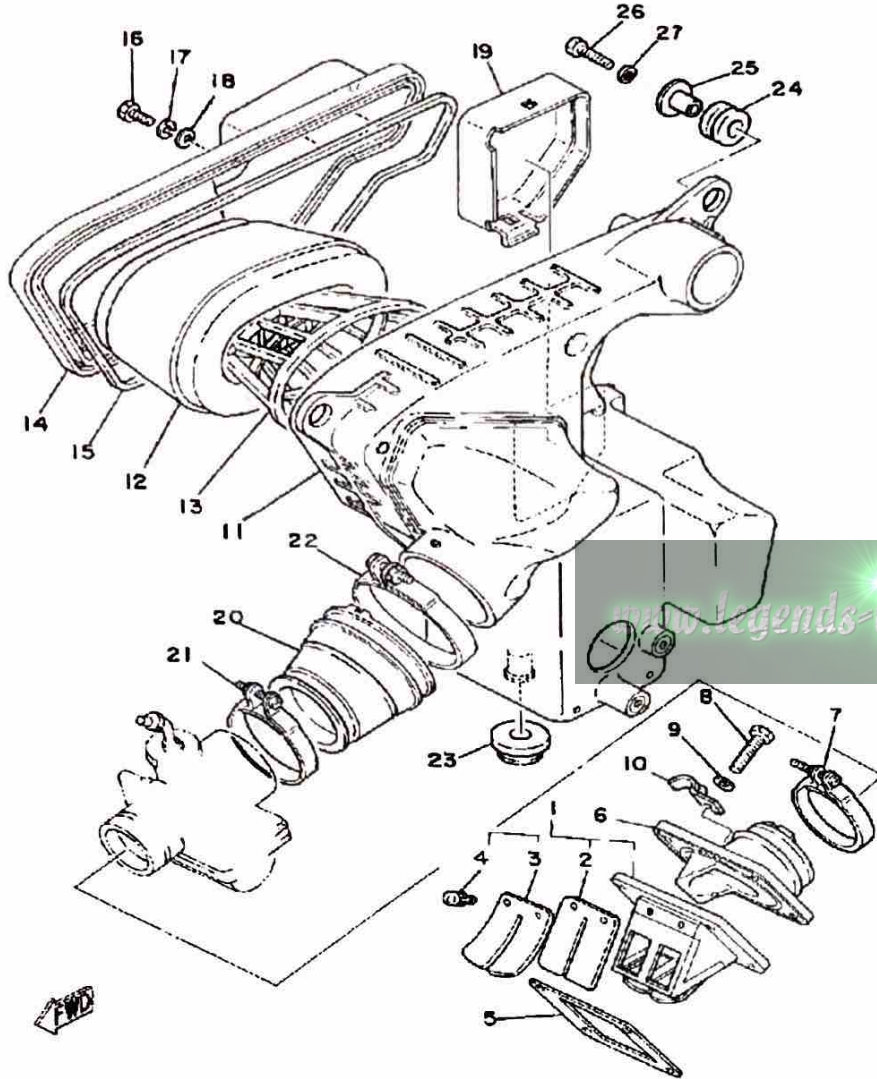

Ref. No.	Part Number	Description	Qty	Remarks
1	558-13610-00-00	REED VALVE ASSEMBLY	1	
2	345-13613-70-00	. REED, VALVE	2	
3	345-13616-70-00	. STOPPER, REED VALVE	2	
4	98580-03008-00	. SCREW, PAN HEAD	4	
5	87A-13621-00-00	GASKET, VALVE SEAT	1	
6	401-13565-01-00	JOINT, CARBURETOR	1	
7	90460-43053-00	CLAMP, HOSE	1	
8	97011-06025-00	BOLT (97001-06025)	4	
9	92901-06600-00	WASHER	4	
10	90462-05005-00	CLAMP	1	
11	3M2-14411-00-00	CASE, AIR CLEANER 1	1	
12	2A6-14451-00-00	ELEMENT, AIR CLNR	1	
13	2A6-14458-00-00	UNAVAILABLE IN PRICE BOOK	1	
14	2A6-14412-00-00	CAP, CLEANER CASE 1	1	
15	4L0-14457-01-00	SEAL	1	
16	93580-05012-00	SCREW, PAN HEAD	5	
17	92990-05100-00	WASHER, SPRING	5	
18	92901-05600-00	WASHER, PLATE	5	
19	2A6-14417-00-00	COVER 1	1	
20	2A7-14453-00-00	JOINT, AIR CLNR 1	1	
21	90460-49058-00	CLAMP, HOSE	1	
22	90460-64065-00	CLAMP, HOSE	1	
23	90480-18171-00	GROMMET	1	
24	90480-14023-00	GROMMET	2	
25	90387-07391-00	COLLAR	2	
26	97011-06025-00	BOLT (97001-06025)	2	
27	92995-06100-00	WASHER, SPRING	2	

CARBURETOR

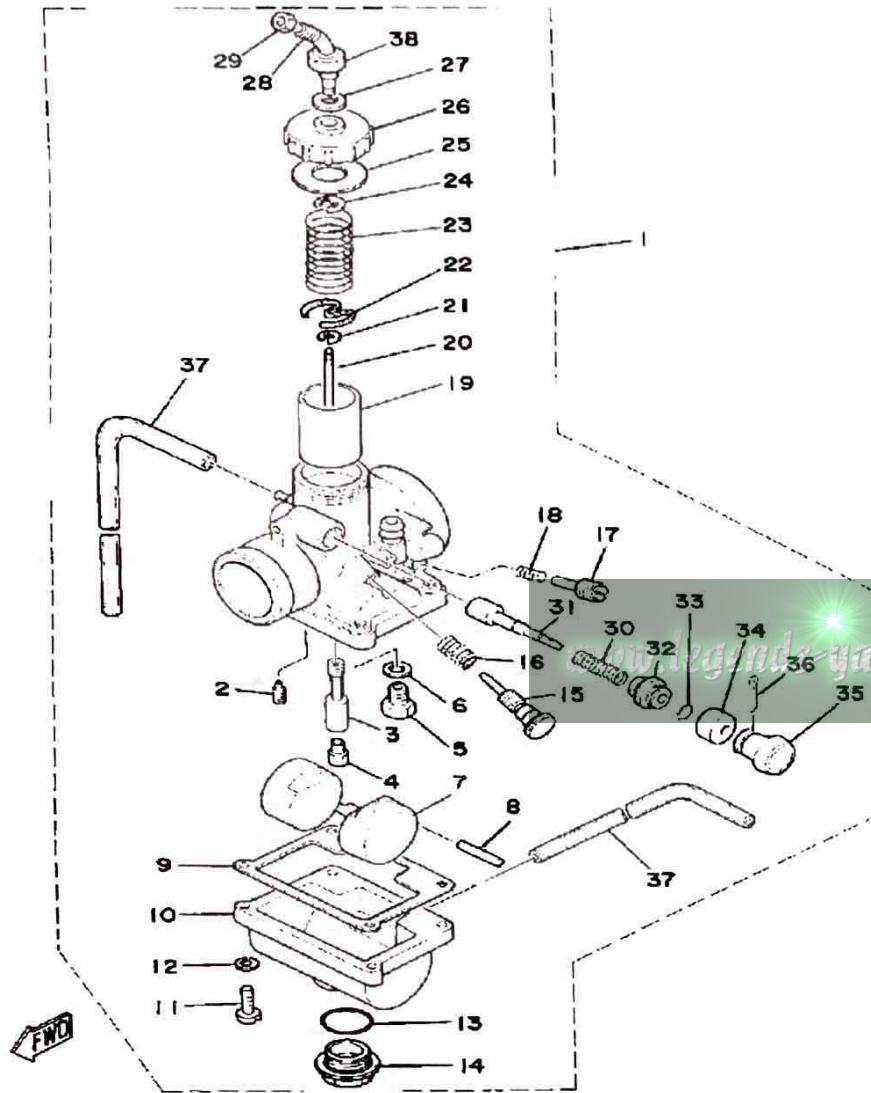

Ref. No.	Part Number	Description	Qty	Remarks
1	3M2-14101-00-00	CARBURETOR ASSEMBLY 1	1	
2	260-14142-27-00	. JET, PILOT (# 27.5)	1	
3	558-14141-32-00	. NOZZLE, MAIN	1	
4	137-14143-25-A0	. JET, MAIN #1 5	1	U.R.
	137-14143-26-A0	. JET, MAIN (#130)	1	U.R.
	137-14143-27-00	. JET, MAIN (#135)	1	U.R.
5	1V0-14190-25-00	. NEEDLE VALVE ASSEMBLY	1	
6	214-14195-00-00	. WASHER, NEEDLE VALVE	1	
7	314-14185-00-00	. FLOAT	1	
8	127-14186-00-00	. PIN, FLOAT	1	
9	304-14184-00-00	. GASKET, FLOAT CHAMBER	1	
10	539-14181-04-00	. BODY, FLOAT CHMBR 1	1	
11	98503-04014-00	. SCREW, PAN HEAD	4	
12	92901-04100-00	. WASHER, SPRING	4	
13	558-14147-00-00	. O-RING	1	
14	500-14115-00-00	. PLUG, SCREW	1	
15	493-14122-00-00	. SCREW, THROTTLE (443-14122-00)	1	
16	493-14133-00-00	. SPRING, THRTL STOP	1	
17	22K-14104-00-00	. AIR SCREW SET	1	
18	174-14134-00-00	. SPRING, AIR ADJUSTING	1	
19	314-14112-30-00	. VALVE, THROTTLE 1	1	
20	18L-1490J-00-00	. NEEDLE	1	
21	363-14137-00-00	. CLIP	1	
22	246-14132-00-00	. STOPPER, CABLE	1	
23	248-14131-00-00	. SPRING, THROTTLE VALVE	1	
24	164-14137-00-00	. CLIP	1	
25	2A6-14126-00-00	. GASKET	1	
26	2A6-14158-00-00	. TOP, MIXING CHAMBER	1	

CONTINUED ON NEXT FRAME ►

CARBURETOR

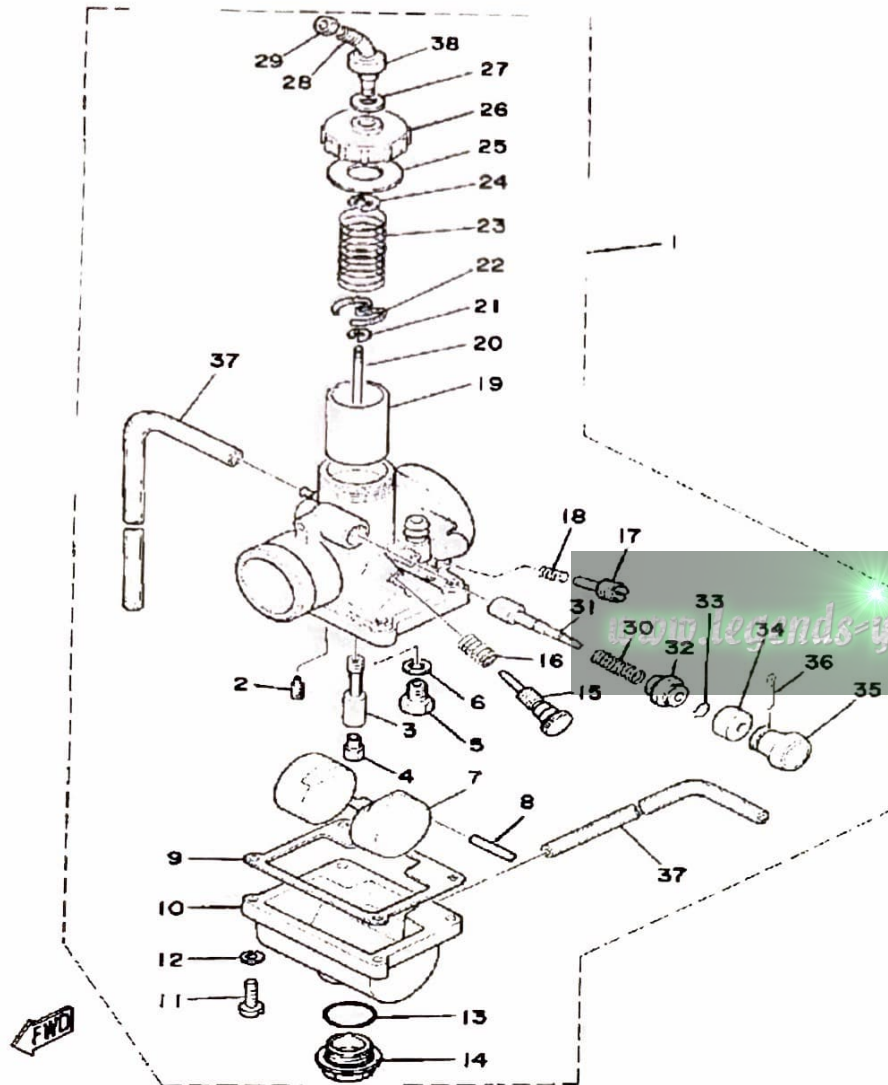

Ref. No.	Part Number	Description	Qty	Remarks
27	509-14198-00-00	. GASKET	1	
28	10X-14106-00-00	. CABLE ADJUST SCREW SET	1	
29	127-14161-00-00	. NUT, CABLE ADJUSTING ...	1	
30	156-14135-00-00	. SPRING, PLUNGER	1	
31	304-14171-00-00	. PLUNGER, STARTER	1	
32	152-14174-00-00	. CAP, PLUNGER	1	
33	353-14138-00-00	. CLIP, PLUNGER	1	
34	132-14173-00-00	. COVER, PLUNGER CAP	1	
35	304-14261-00-00	. HOLDER	1	
36	91490-16020-00	. PIN, COTTER	1	
37	23F-14197-00-00	. PIPE, AIRVENT	2	
38	1M1-14169-00-00	. CAP	1	

EXHAUST

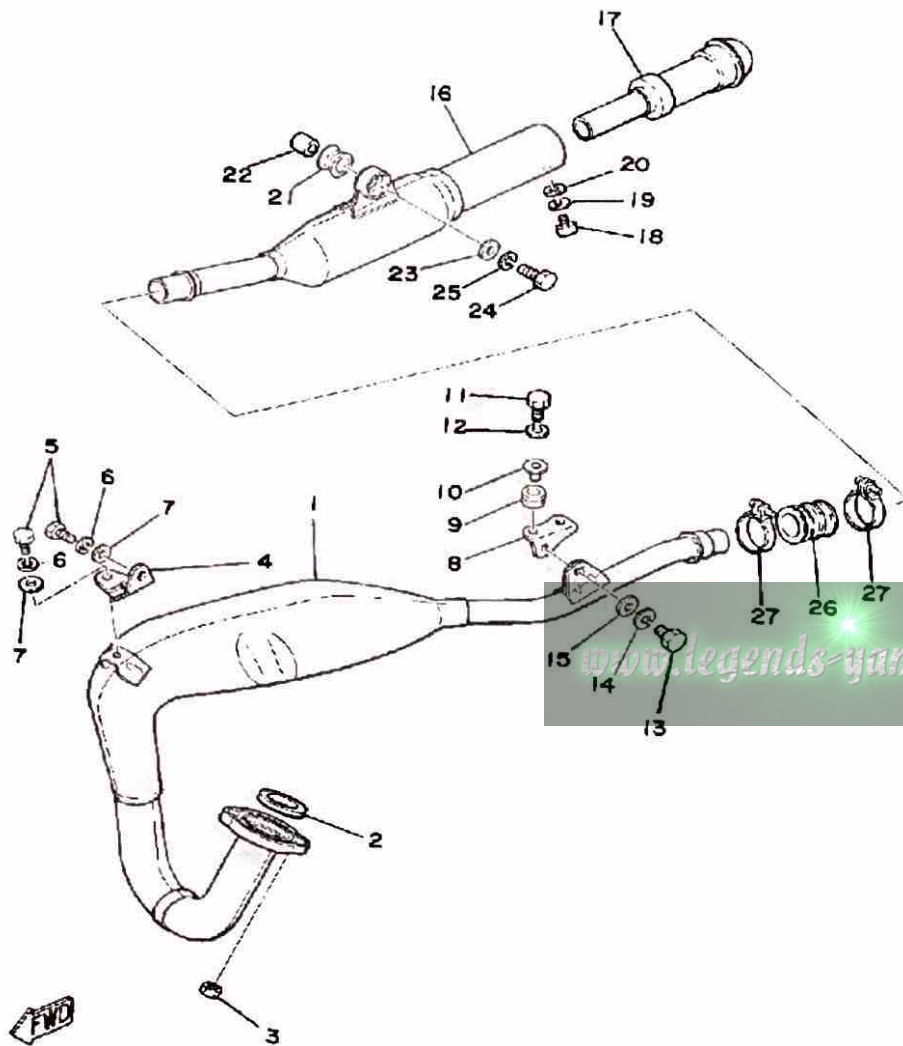

Ref. No.	Part Number	Description	Qty	Remarks
1	3J0-14610-00-00	EXHAUST PIPE ASSEMBLY L (2A6-14610-00)	1	
2	152-14613-00-00	GASKET, EXST PIPE	1	
3	95380-06600-00	NUT	2	
4	2A6-14772-00-00	STAY, MUFFLER 2	1	
5	97313-08018-00	BOLT, HEXAGON (97301-08016)	2	
6	92990-08100-00	WASHER	2	
7	92901-08600-00	WASHER	2	
8	5V7-14771-00-00	STAY, MUFFLER 1	1	
9	90480-14023-00	GROMMET	2	
10	90387-06388-00	COLLAR	2	
11	97011-06025-00	BOLT (97001-06025)	2	
12	92995-06100-00	WASHER, SPRING	2	
13	97313-08018-00	BOLT, HEXAGON (97301-08016)	1	
14	92990-08100-00	WASHER	1	
15	92901-08600-00	WASHER	1	
16	2A6-14753-00-00	SILENCER, EXHAUST	1	
17	1M1-14752-01-00	PIPE, OUTLET	1	
18	98580-06012-00	SCREW, PAN HEAD	1	
19	92995-06100-00	WASHER, SPRING	1	
20	92901-06600-00	WASHER	1	
21	565-14747-00-00	DAMPER, MUFFLER	1	
22	90387-08258-00	COLLAR	1	
23	90201-08753-00	WASHER, PLATE	1	
24	97313-08030-00	BOLT, HEXAGON	1	
25	92990-08100-00	WASHER	1	
26	1W2-14714-00-00	GASKET, MUFFLER	1	
27	90460-37026-00	CLAMP, HOSE	2	

CRANKCASE

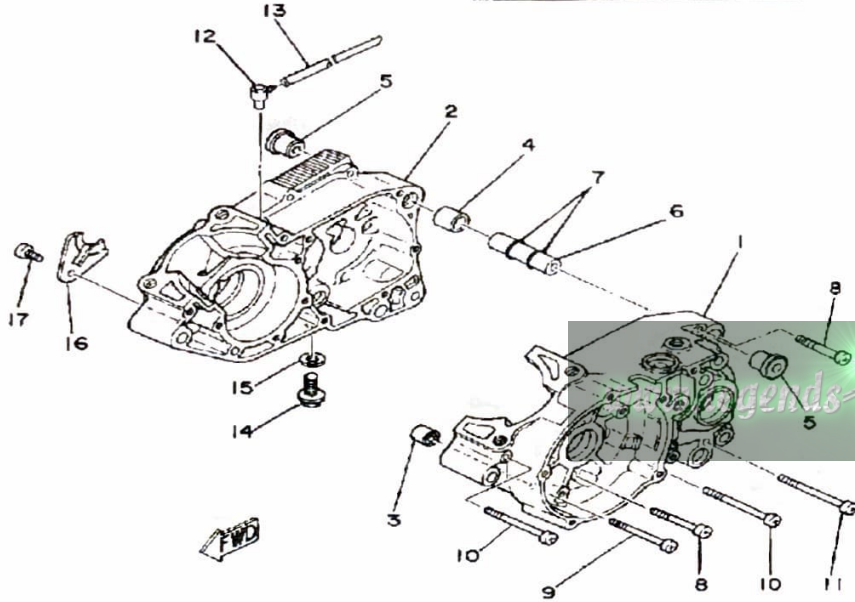
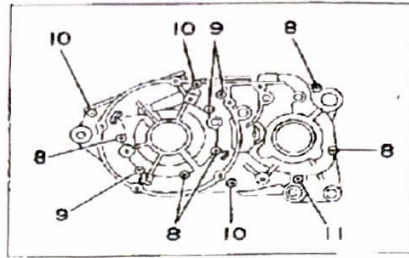

Ref. No.	Part Number	Description	Qty	Remarks
2	2A6-15121-01-00	CRANKCASE 2	1	
3	99530-10014-00	PIN, DOWEL	1	
4	99510-20020-00	PIN, DOWEL	1	
5	328-15316-00-00	DAMPER, ENG MOUNT 1 (328-15316-00)	2	
6	401-15317-00-00	SPACER, ENG MOUNT	1	
7	93210-11073-00	O-RING	2	
8	98580-06550-00	SCREW PAN HEAD (92503-06050)	5	
9	92580-06560-00	SCREW PAN HEAD	3	
10	98501-06070-00	SCREW, PAN HEAD	3	
11	98501-06075-00	SCREW, PAN HEAD	1	
12	2N4-15371-00-00	BREATHER	1	
13	90445-07340-00	HOSE	1	
14	90340-12005-00	PLUG, DRAIN	1	
15	90430-12207-00	GASKET	1	
16	304-15128-00-00	HOLDER	1	
17	92501-08010-00	SCREW, PAN HEAD	1	

CRANKCASE-COVER

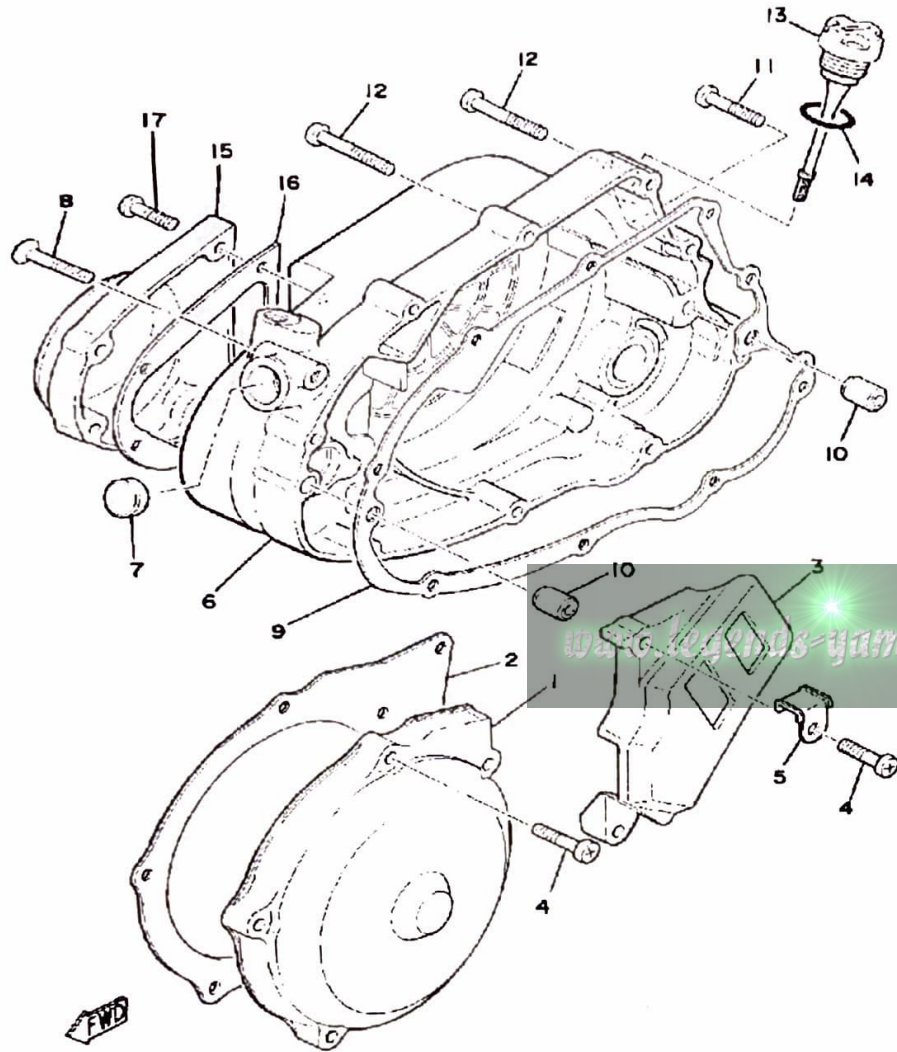

Ref. No.	Part Number	Description	Qty	Remarks
1	1W1-15411-00-00	COVER, CRANKCASE L	1	
2	1W1-15455-00-00	GASKET 1	1	
3	1W1-15421-01-00	COVER, CRANKCASE R	1	
4	98511-06025-00	SCREW PAN HEAD (92501-06025)	7	
5	2A6-15484-01-00	CLAMP 2	1	
6	2A6-15431-00-00	COVER, CRANKCASE 3	1	
7	90338-19078-00	PLUG	1	
8	92601-06030-00	SCREW, OVAL HEAD	1	
9	18G-15451-01-00	GASKET, CRCS. COVER	1	
10	99530-10014-00	PIN, DOWEL	2	
11	98580-06030-00	SCREW PAN HEAD	3	
12	98580-06040-00	SCREW, pan head (92501-06040-00)	6	
13	18G-15362-00-00	PLUG, OIL LEVEL	1	
14	93210-21190-00	O-RING	1	
15	2A6-15416-00-00	COVER, OIL PUMP	1	
16	2A6-15456-00-00	GASKET, O/PMP CVR 1	1	
17	98511-06025-00	SCREW PAN HEAD (92501-06025)	4	

KICK STARTER

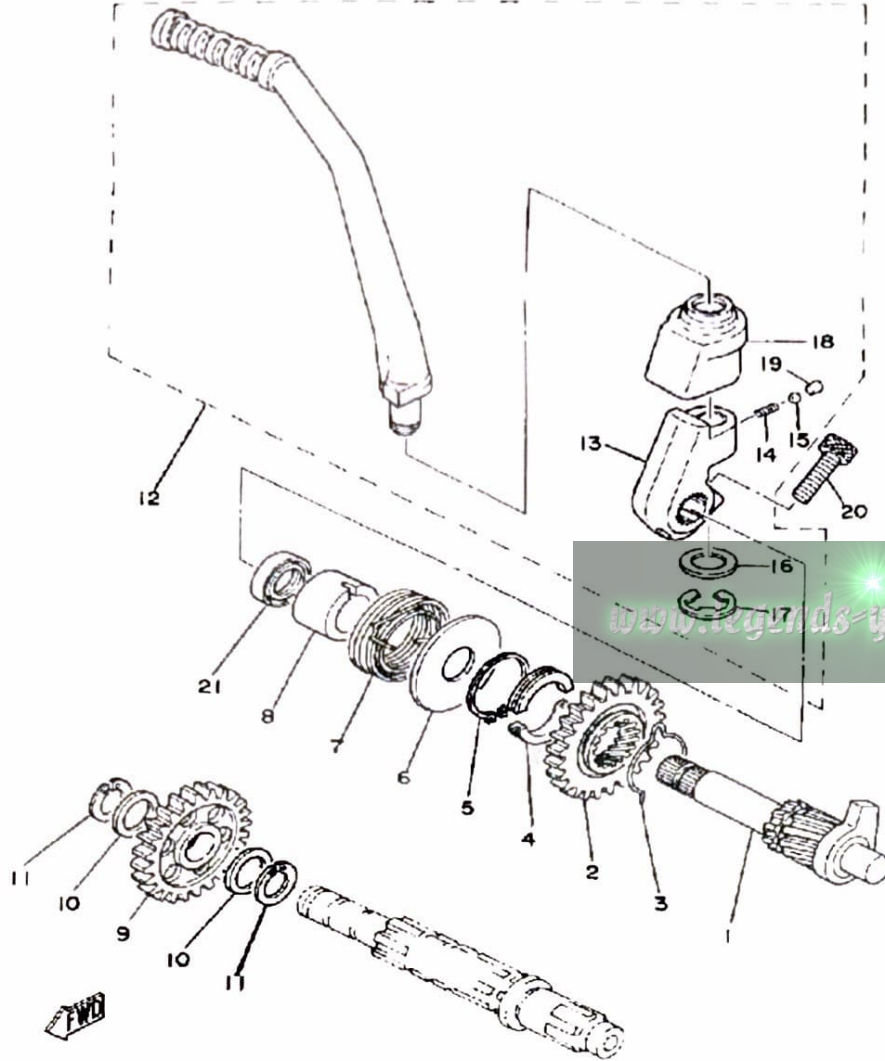

Ref. No.	Part Number	Description	Qty	Remarks
1	2A6-15660-01-00	KICK AXLE ASSEMBLY	1	
2	1W1-15641-00-00	GEAR, KICK (27T)	1	
3	90468-26048-00	CLIP	1	
4	248-15654-00-00	HOLDER, KICK GEAR	2	
5	99009-30400-00	CIRCLIP	1	
6	401-15676-00-00	COVER, SPRING	1	
7	90508-26346-00	SPRING, TORSION	1	
8	1W1-15666-00-00	SPACER	1	
9	525-15651-00-00	GEAR, KICK IDLE (25T)	1	
10	137-17417-00-05	SHIM 1 (0.5T)	2	
11	93440-15012-00	CIRCLIP	2	
12	1W1-15620-01-00	KICK CRANK ASSEMBLY (1W1-15611-02-33)	1	
13	1W1-15621-01-00	BOSS, KICK CRANK	1	
14	90501-10459-00	SPRING, COMPRESSION	1	
15	93503-16010-00	BALL	1	
16	90201-12541-00	WASHER, PLATE	1	
17	93430-08007-00	CIRCLIP	1	
18	1W1-15618-01-00	COVER, KICK LEVER	1	
19	90336-06030-00	PLUG, TAPER	1	
20	91316-08025-00	BOLT, SOCKET HEAD	1	
21	93101-17062-00	OIL SEAL	1	

CLUTCH

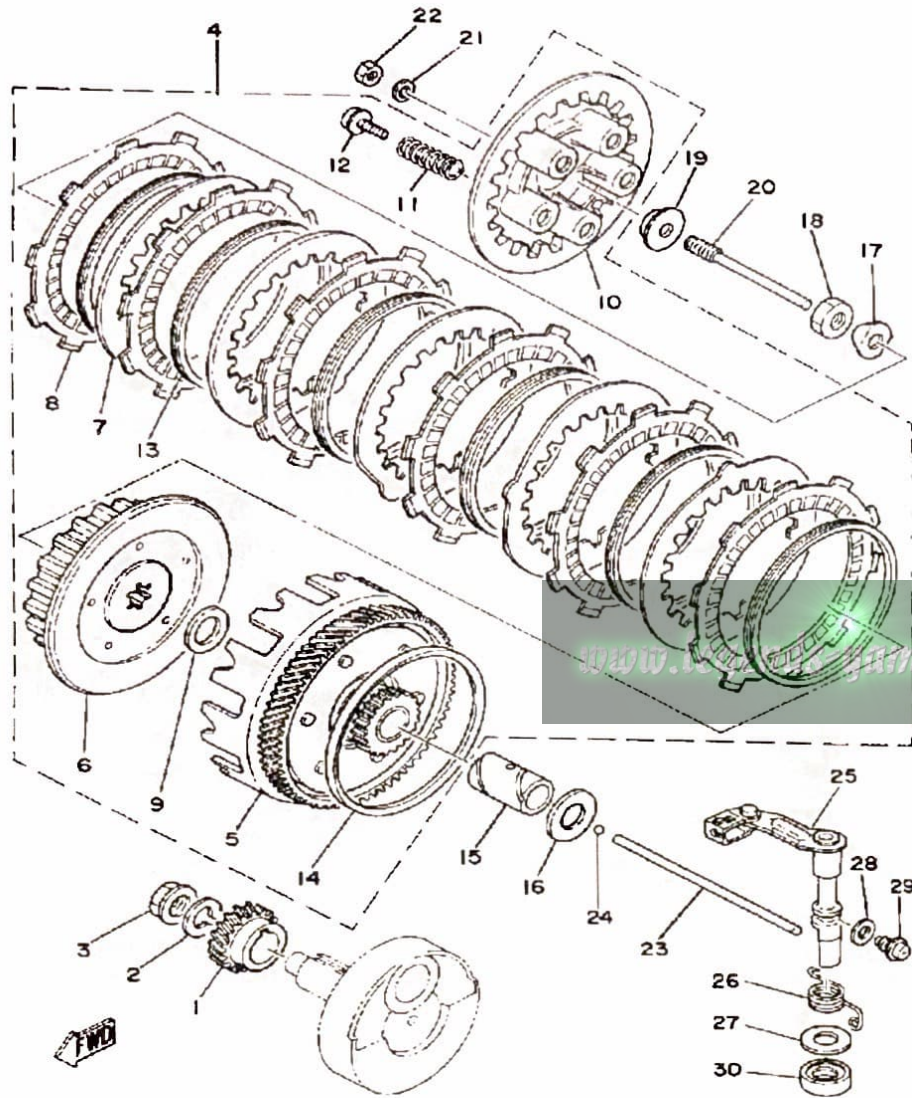

Ref. No.	Part Number	Description	Qty	Remarks
1	1W1-16111-00-00	GEAR, PRI DRIVE	1	
2	90204-12007-00	WASHER, SPRING	1	
3	90179-12244-00	NUT, SPEC'L SHAPE	1	
4	3J1-16300-00-00	CLUTCH ASSEMBLY CLUTCH ASSEMBLY (2A7-16301-00)	1	
5	2A7-16150-00-00	. PRI DRVN GEAR COMP. (71T)	1	
6	1G8-16371-00-00	. BOSS, CLUTCH	1	
7	2A6-16324-00-00	. PLATE, CLUTCH 1	5	
8	559-16321-01-00	. PLATE, FRICTION	6	
9	90201-17543-00	. WASHER, PLATE	1	
10	1W1-16351-00-00	. PLATE, PRESSURE 1	1	
11	90501-20474-00	. SPRING, COMPRESSION	5	
12	90159-05011-00	. SCREW, WITH WASHER	5	
13	307-16367-00-00	. RING, CUSHION	6	
14	(2A7-16369-00-00)	RING, FRICTION	1	
15	90560-17147-00	SPACER	1	
16	90201-174E1-00	WASHER, PLATE	1	
17	90215-14204-00	WASHER, LOCK	1	
18	90170-14171-00	NUT	1	
19	30X-16358-00-00	PLATE, PUSH	1	
20	1W1-16356-02-00	ROD, PUSH 1	1	
21	92990-06200-00	WASHER	1	
22	95380-06600-00	NUT	1	
23	2X3-16357-00-00	ROD, PUSH 2	1	
24	93503-16010-00	BALL	1	
25	2X3-16380-01-00	PUSH LEVER ASSEMBLY	1	
26	90508-20345-00	SPRING, TORSION	1	
27	90201-14217-00	WASHER, PLATE	1	
28	90430-08069-00	GASKET	1	

CONTINUED ON NEXT FRAME ►

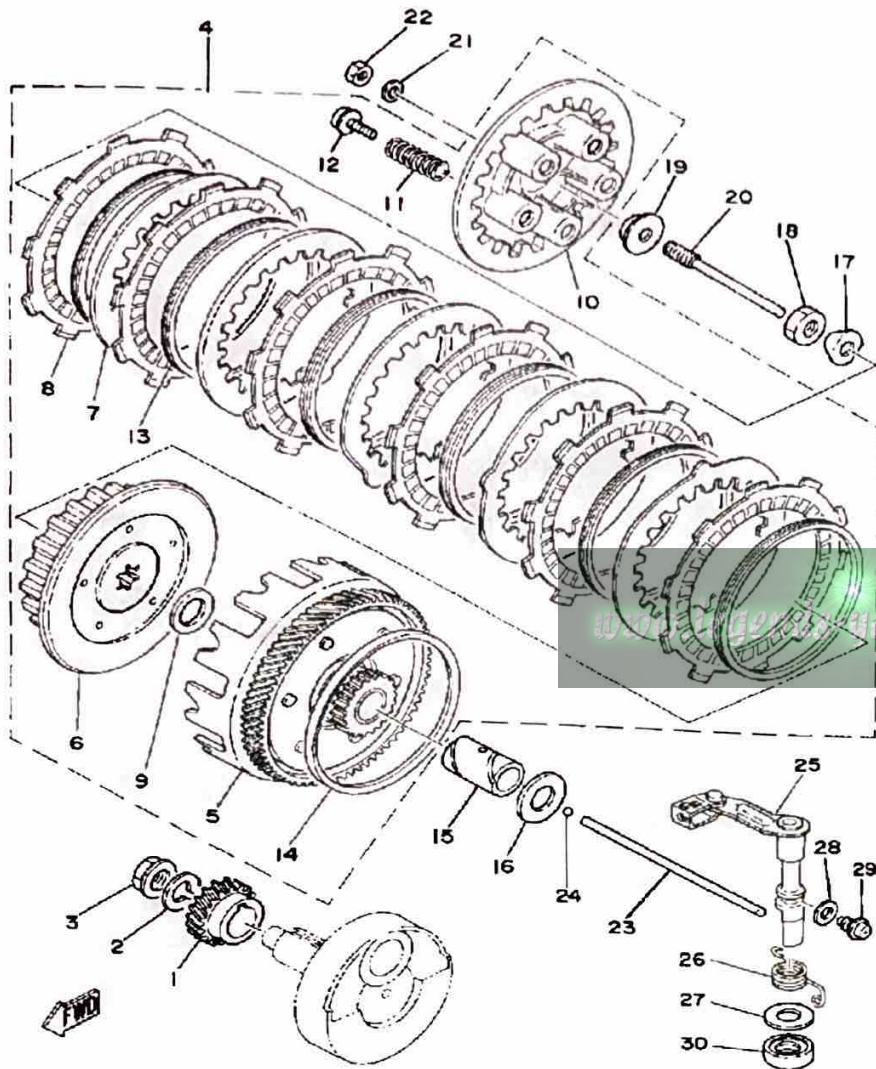

CLUTCH

Ref. No.	Part Number	Description	Qty	Remarks
29	90149-08108-00	SCREW, SPEC"L SHAPE 1	
30	93104-14059-00	OIL SEAL, SO-TYPE 1	

www.yamaha-enduros.com

TRANSMISSION

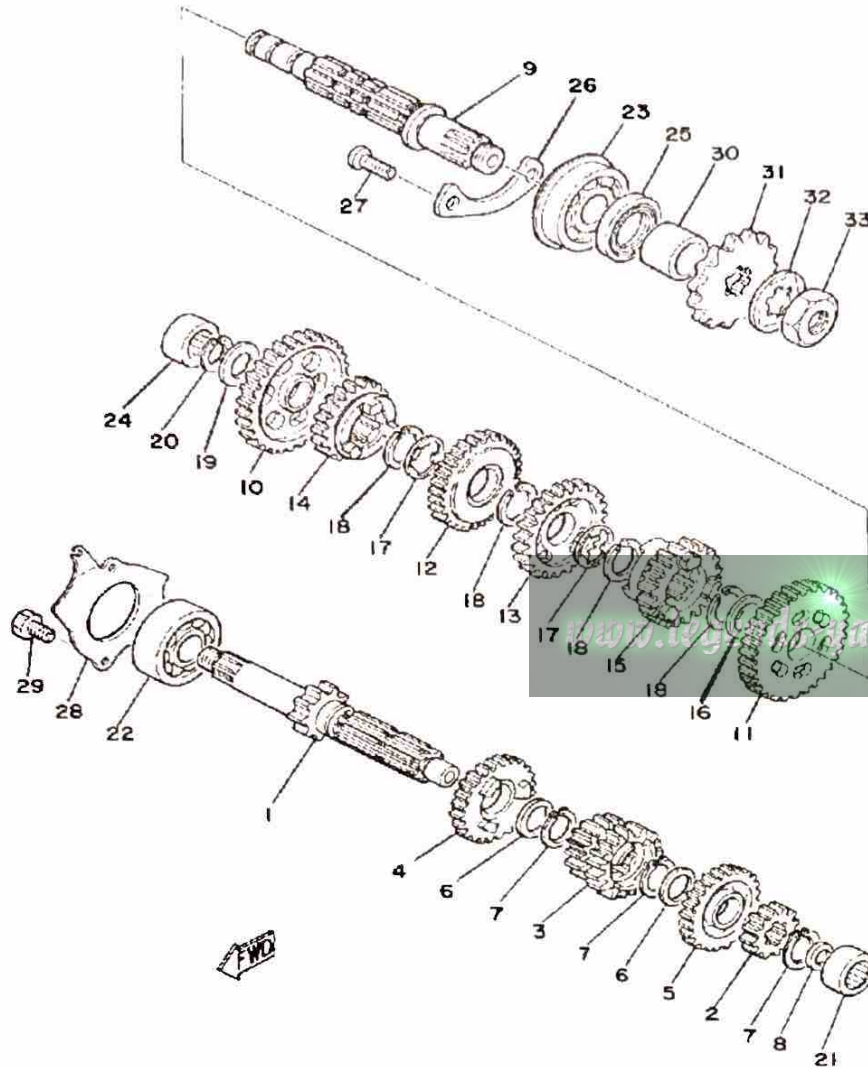

Ref. No.	Part Number	Description	Qty	Remarks
1	2A6-17411-00-00	AXLE, MAIN	1	
2	2A6-17121-00-00	GEAR, 2ND PINION	1	
3	2A6-17131-00-00	GEAR, 3RD PINION	1	
4	1W2-17151-00-00	GEAR, 5TH PINION	1	
5	1W2-17161-00-00	GEAR, 6TH PINION	1	
6	90201-20266-00	WASHER, PLATE (1.0T)	2	
7	93410-20038-00	CIRCLIP	3	
8	90201-15701-00	WASHER, PLATE (1.0T)	1	
9	2A6-17421-00-00	AXLE, DRIVE	1	
10	2A6-17211-01-00	GEAR, 1ST WHEEL (2A6-17211-00)	1	
11	2A6-17221-01-00	GEAR, 2ND WHEEL (2A6-17221-00)	1	
12	2A6-17231-00-00	GEAR, 3RD WHEEL	1	
13	1W2-17241-00-00	GEAR, 4TH WHEEL	1	
14	2A6-17251-00-00	GEAR, 5TH WHEEL	1	
15	2A6-17261-00-00	GEAR, 6TH WHEEL	1	
16	90201-22555-00	WASHER, PLATE	1	
17	90209-18135-00	WASHER	2	
18	93410-22039-00	CIRCLIP	4	
19	90201-15701-00	WASHER, PLATE (1.0T)	1	
20	93440-15012-00	CIRCLIP	1	
21	93311-41530-00	BEARING	1	
22	93306-30309-00	BEARING	1	
23	93306-30411-00	BEARING (B6304)	1	
24	93311-31567-00	BEARING, CYLINDRICAL	1	
25	93102-26042-00	OIL SEAL	1	
26	1W1-15381-00-00	PLATE, BRNG COVER	1	
27	98603-06012-00	SCREW, OVAL HEAD (92701-06012)	2	

CONTINUED ON NEXT FRAME ►

TRANSMISSION

Ref. No.	Part Number	Description	Qty	Remarks
28	1W1-17471-01-00	PLATE, COVER	1	
29	97013-06012-00	BOLT	2	
30	90387-202A0-00	COLLAR	1	
31	93822-14037-00	SPROCKET, DRIVE 14T (1741746140)	1	U.R.
	93822-15065-00	SPROCKET, DRIVE 15T (1741746150)	1	U.R.
	93822-16093-00	SPROCKET, DRIVE	1	U.R.
32	90215-16127-00	WASHER, LOCK	1	
33	90179-16226-00	NUT	1	

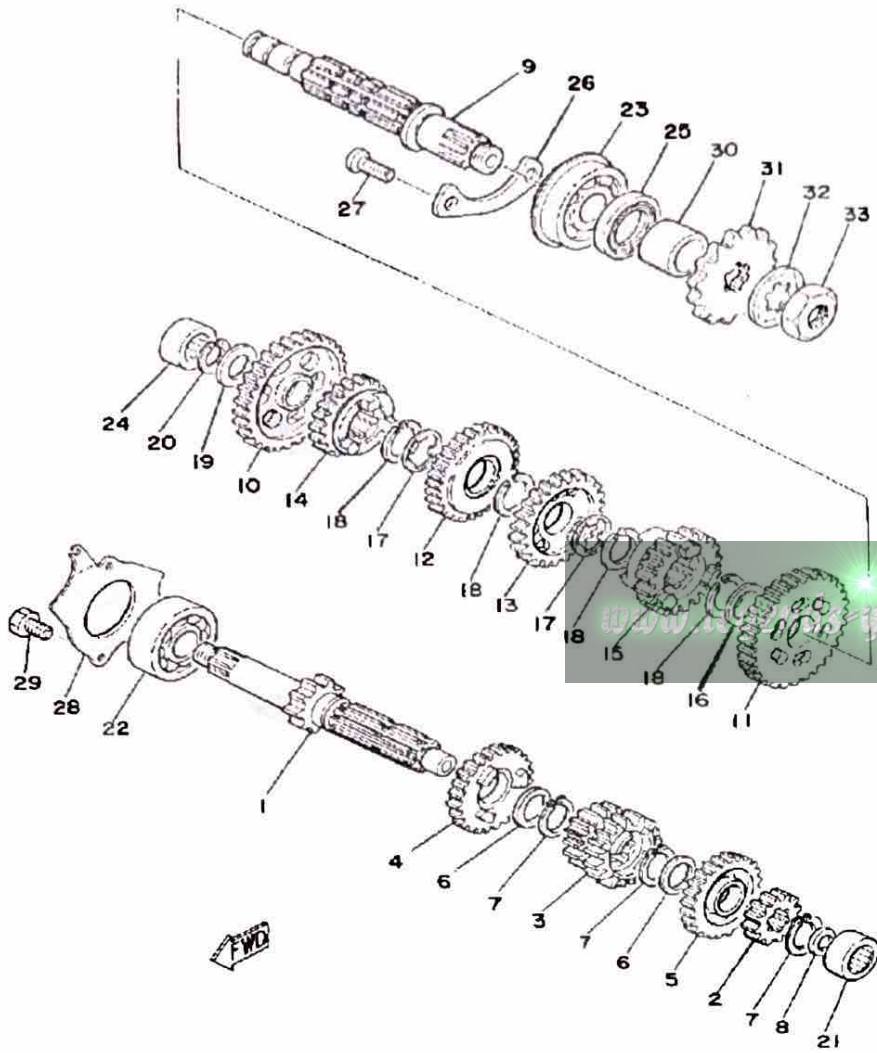

SHIFT CAM-FORK

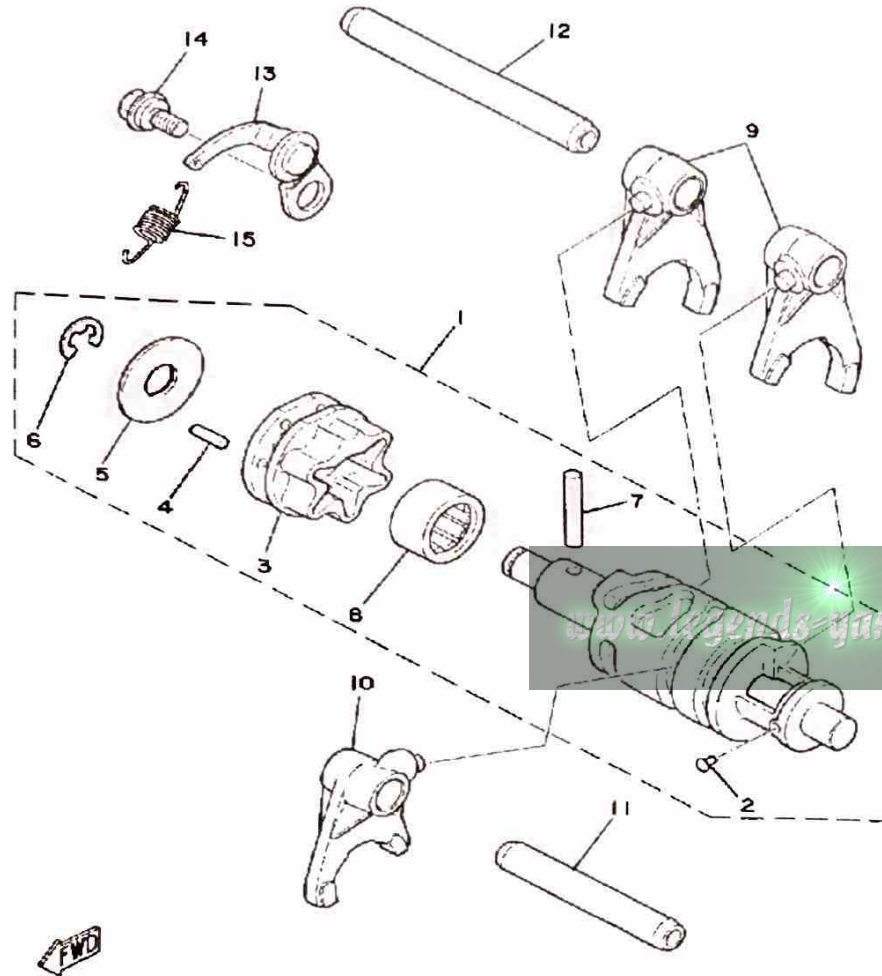

Ref. No.	Part Number	Description	Qty	Remarks
1	1W1-18540-00-00	SHIFT CAM ASSEMBLY	1	
2	136-18542-00-00	. POINT, NEUTRAL	1	
3	1W1-18185-00-00	. SEGMENT	1	
4	93604-12037-00	. PIN, DOWEL	6	
5	1W1-18561-00-00	. PLATE, SIDE 1	1	
6	99001-08600-00	. CIRCLIP	1	
7	93604-30018-00	. PIN, DOWEL	1	
8	93315-21813-00	. BEARING	1	
9	2A6-18511-00-00	FORK, SHIFT 1	2	
10	2A6-18512-00-00	FORK, SHIFT 2	1	
11	2A6-18531-00-00	BAR, SHIFT FORK GUIDE 1	1	
12	2A6-18535-00-00	BAR, SHIF FRK GDE 2	1	
13	1W1-18140-00-00	STOPPER LEVER ASSEMBLY	1	
14	50W-21631-00-00	BOLT 1	1	
15	90506-09156-00	SPRING, TENSION	1	



SHIFT SHAFT-PEDAL

Ref. No.	Part Number	Description	Qty	Remarks
1	4F2-18120-00-00	SHIFT LEVER ASSEMBLY (2A6-18120-00)	1	
2	90506-08155-00	SPRING, TENSION	1	
3	90508-32349-00	SPRING, TORSION	1	
4	99006-10600-00	CIRCLIP	1	
5	1W1-18101-03-00	SHIFT SHAFT ASSEMBLY 1	1	
6	401-18178-00-00	ROLLER, SHIFT LEVER	1	
7	99006-10600-00	CIRCLIP	1	
8	2A6-18111-00-00	PEDAL, SHIFT	1	
9	132-18113-01-00	COVER, SHIFT PEDAL	1	
10	97011-06020-00	BOLT	1	
11	90149-08111-00	SCREW, SPEC'L SHAPE	1	
12	90170-08029-00	NUT	1	
13	90215-08014-00	WASHER, LOCK	1	
14	93101-12060-00	OIL SEAL	1	
15	1W1-18197-01-00	SHAFT	1	
16	90201-12M34-00	WASHER, PLATE	1	
17	99006-10600-00	CIRCLIP	1	

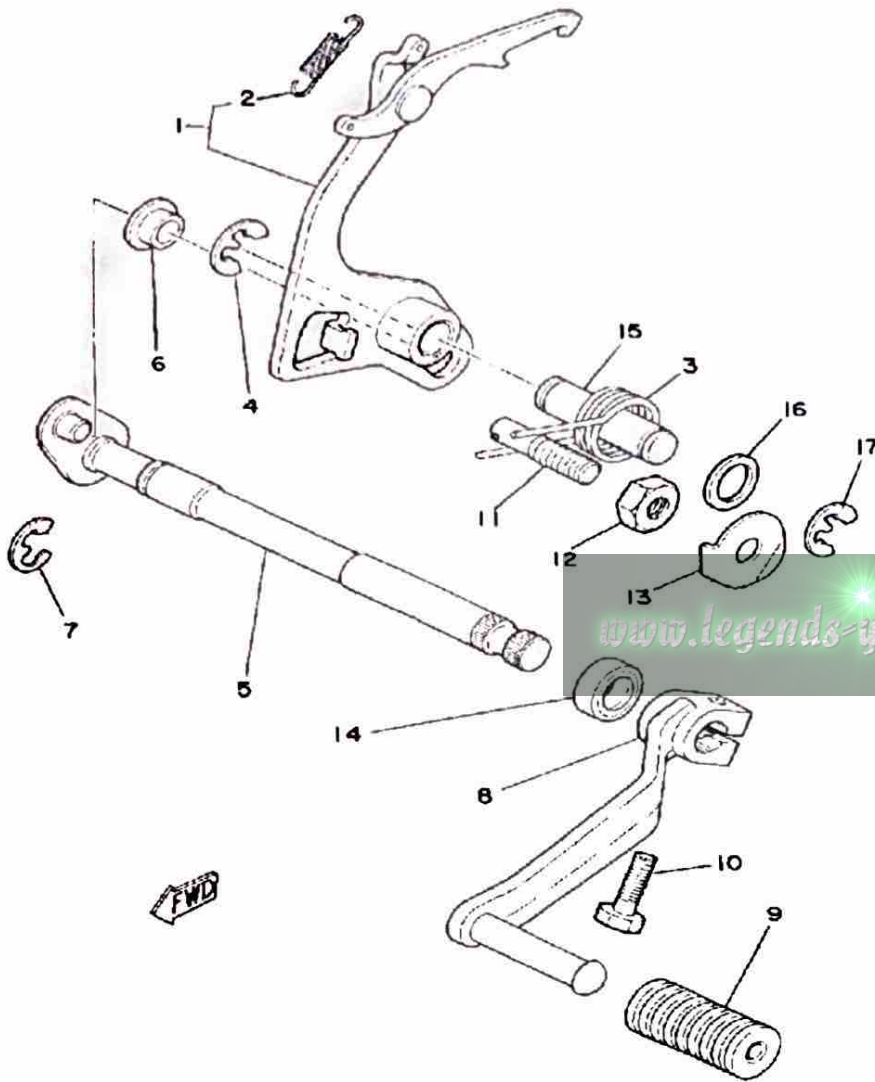

FRAME-TOOL

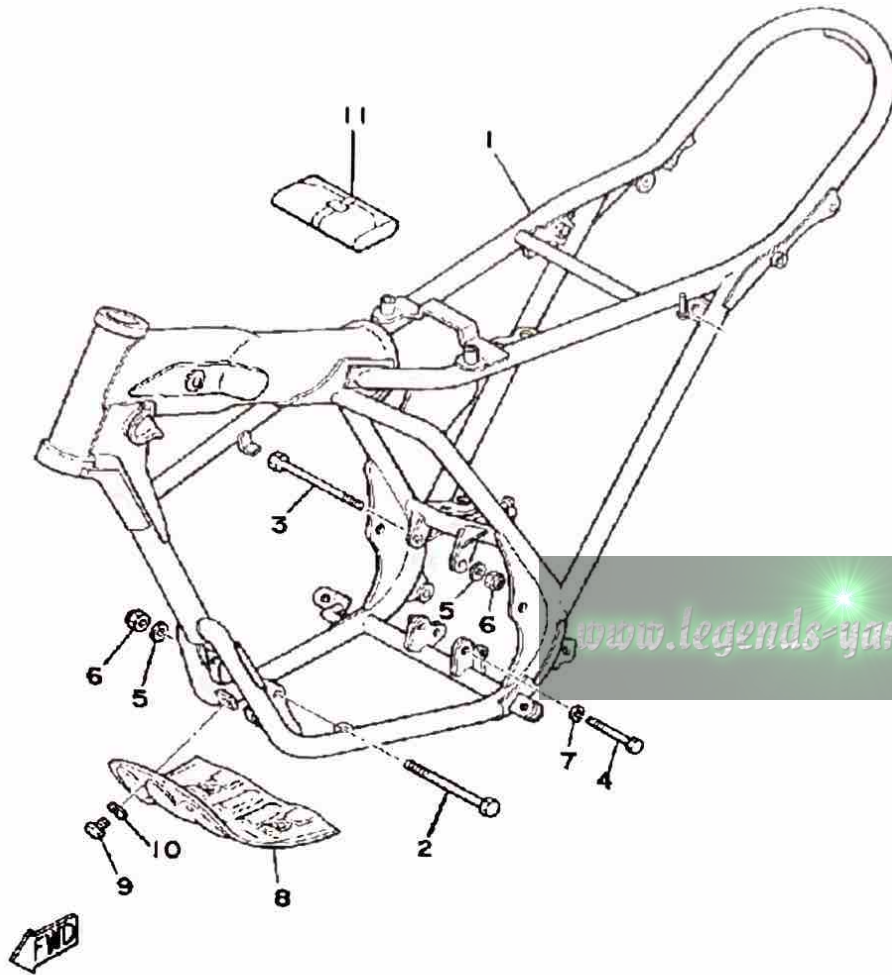

Ref. No.	Part Number	Description	Qty	Remarks
1	(3M2-21110-00-33)	FRAME	1	YAMAHA BLACK
2	90105-08099-00	BOLT, WASHER BASED	1	
3	90105-08120-00	BOLT, WASHER BASED	1	
4	90105-10037-00	BOLT, WASHER BASED	1	
5	92990-08200-00	WASHER, PLAIN	2	
6	90185-08089-00	NUT, SELF-LOCKING	2	
7	92990-10100-00	WASHER, SPRING	1	
8	(2A6-21471-00-90)	PROTECTOR, ENGINE	1	UNI CHROME6(BLACK)
9	97013-06012-00	BOLT	4	
10	92901-06600-00	WASHER	4	
11	2A6-W2810-00-00	TOOL KIT	1	

FRONT FENDER-REAR FENDER

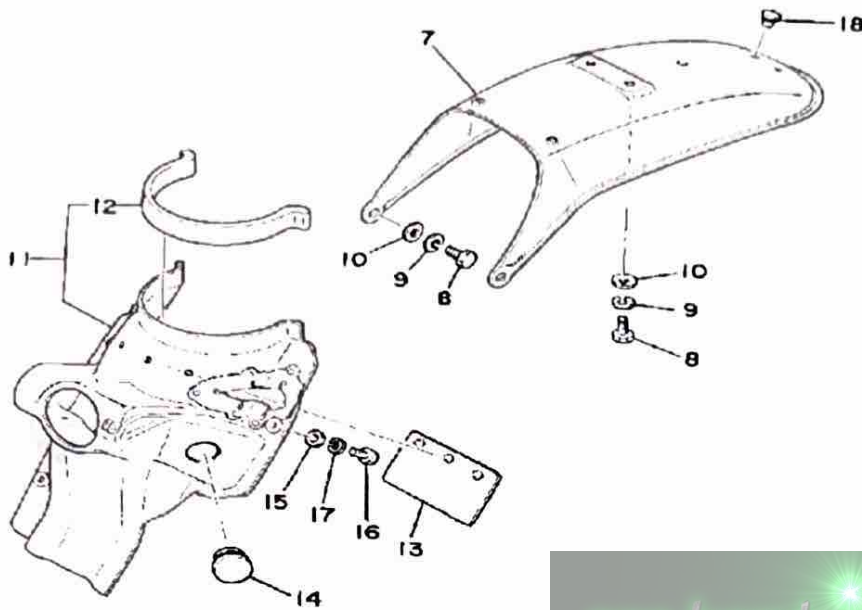

Ref. No.	Part Number	Description	Qty	Remarks
1	3J0-21511-00-00	FENDER, FRONT	1	CLEAN WHITE
2	90201-06067-00	WASHER, PLATE	4	
3	90480-14198-00	GROMMET	4	
4	90387-06388-00	COLLAR	4	
5	97011-06025-00	BOLT (97001-06025)	4	
6	92995-06100-00	WASHER, SPRING	4	
7	2A8-21611-80-00	FENDER, REAR	1	CLEAN WHITE
8	97313-06016-00	BOLT, HEXAGON	4	
9	92995-06100-00	WASHER, SPRING	4	
10	92990-06200-00	WASHER	4	
11	(99999-01151-00)	GUARD, MUD	1	
12	2A6-21639-00-00	. DAMPER 2	1	
13	1M1-21621-00-00	FLAP	1	
14	90480-01254-00	GROMMET	2	
15	90201-06067-00	WASHER, PLATE	3	
16	97313-06016-00	BOLT, HEXAGON	3	
17	92995-06100-00	WASHER, SPRING	3	
18	90480-12012-00	GROMMET	3	

www.legends-yamaha-enthusiast.com

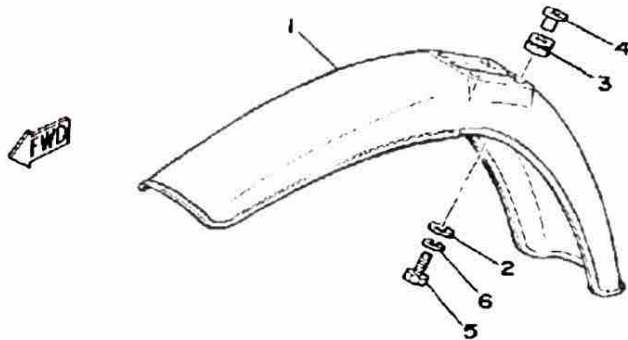

SIDE COVER

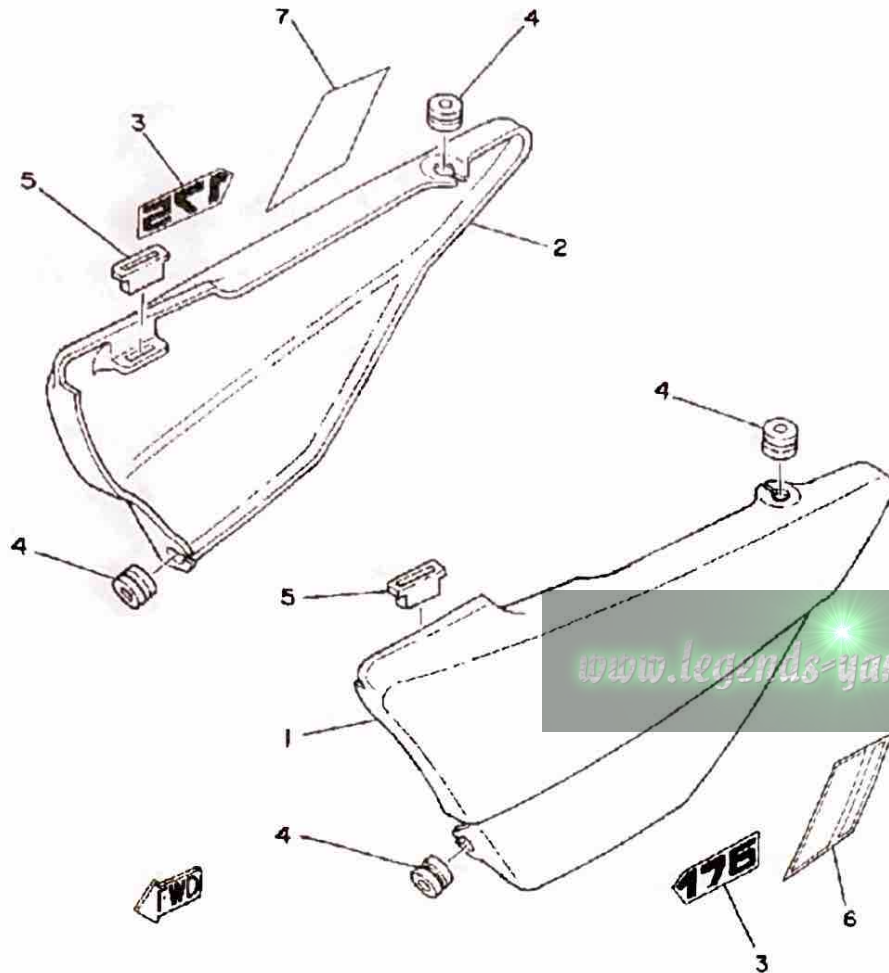

Ref. No.	Part Number	Description	Qty	Remarks
1	2N4-21711-01-36	COVER, SIDE 1	1	CLEAN WHITE
2	2N4-21721-01-36	COVER, SIDE 2	1	CLEAN WHITE
3	3M2-21786-10-00	EMBLEM 6	2	
4	90480-12053-00	GROMMET	4	
5	2N4-21717-00-00	DAMPER	2	
6	3M2-21784-00-00	EMBLEM 4	1	
7	(3M2-21785-00-00)	EMBLEM 5	1	

OIL TANK

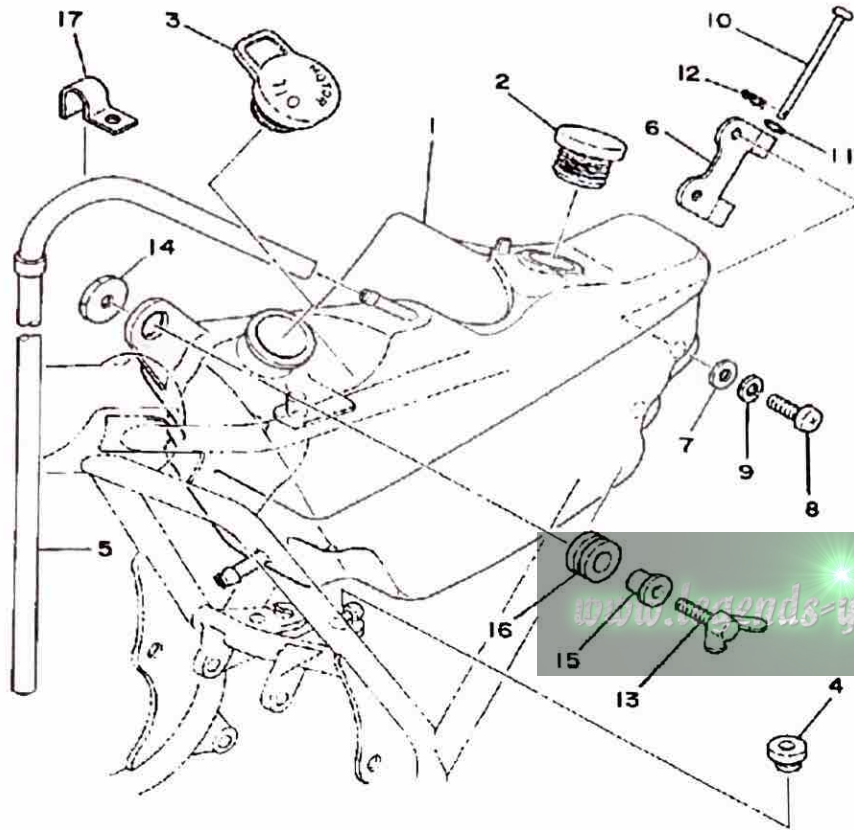

Ref. No.	Part Number	Description	Qty	Remarks
1	2A6-21751-00-00	TANK, OIL	1	
2	3M2-21771-00-00	BODY, CAP	1	
3	1T9-21771-00-00	BODY, CAP	1	
4	90480-18171-00	GROMMET	1	
5	90445-09361-00	HOSE	1	
6	2A6-21796-00-00	HINGE	1	
7	90201-06067-00	WASHER, PLATE	2	
8	98503-06014-00	SCREW, PAN HEAD (92502-06016)	2	
9	92995-06100-00	WASHER, SPRING	2	
10	91701-05050-00	PIN, CLEVIS	1	
11	93210-04122-00	O-RING	1	
12	90468-10050-00	CLIP	1	
13	90122-06021-00	BOLT, WING (38W)	1	
14	90179-06013-00	NUT, SPEC"L SHAPE	1	
15	90387-07391-00	COLLAR	1	
16	90480-14023-00	GROMMET	1	
17	90462-05005-00	CLAMP	1	



REAR ARM

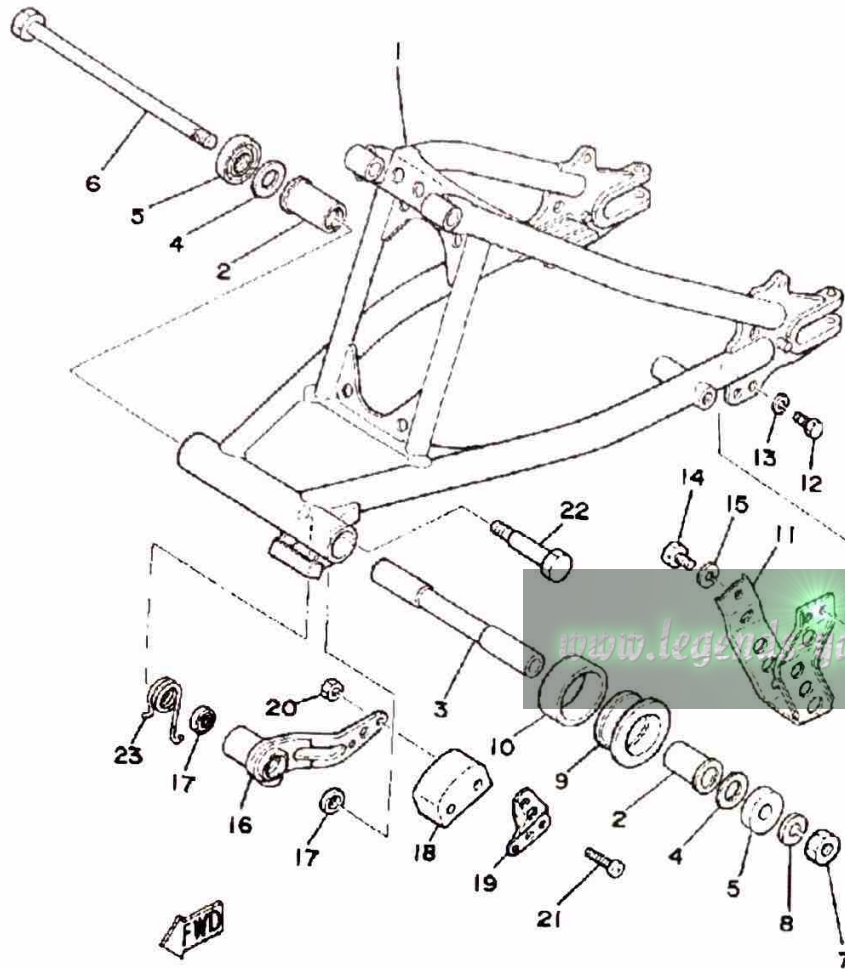

Ref. No.	Part Number	Description	Qty	Remarks
1	(3M2-22110-01-33)	REAR ARM	1	YAMAHA BLACK
2	90386-18028-00	BUSH	2	
3	18G-22124-00-00	BUSH 2	1	
4	401-22127-00-00	SHIM	1	U.N.
5	401-22128-01-00	SEAL, GUARD	2	
6	2N4-22141-00-00	SHAFT, PIVOT	1	
7	90185-12046-00	NUT, SELF-LOCKING	1	
8	92901-12100-00	WASHER, SPRING	1	
9	2A6-22151-00-00	SEAL, GUARD	1	
10	2A6-22152-00-00	SEAL, GUARD	1	
11	2A6-22318-00-00	GUARD, CHAIN	1	
12	97313-06016-00	BOLT, HEXAGON	2	
13	92995-06100-00	WASHER, SPRING	2	
14	97313-08012-00	BOLT	1	
15	92990-08100-00	WASHER	1	
16	2A6-22179-00-00	ARM, TENSIONER	1	
17	93104-14044-00	OIL SEAL	2	
18	ACC-11130-00-25	TENSIONER (2N0-22178-00-00)	1	
19	1W1-22187-00-00	GUIDE, CHAIN	1	
20	95311-05700-00	NUT	2	
21	98501-05035-00	SCREW, PAN HEAD	2	
22	90109-10483-00	BOLT (90109-10533-00)	1	
23	90508-35350-00	SPRING, TORSION	1	

REAR SUSPENSION

Ref. No.	Part Number	Description	Qty	Remarks
1	(3J0-22210-00-00)	SHK/ABS ASSEMBLY, REAR	1	
2	(3J0-22401-00-00)	DAMPER SUB-ASSEMBLY.	1	
3	90380-12051-00	.. BUSH, SOLID	2	
4	1W1-22226-00-00	.. BUSH, SHOCK ABS LWR	1	
5	(3J0-22493-00-00)	BUMP, STOP	1	
6	(2N4-22496-00-00)	SLEEVE, ROD	1	
7	(2N4-22214-00-00)	GUIDE, SPRING 1	1	
8	(2N4-22213-00-00)	SEAT, SPRING UPPER	1	
9	(1M1-22219-01-00)	BRACKET, UPPER	1	
10	91401-30040-00	. PIN, COTTER	1	
11	(90501-90554-00)	SPRING, COMPRESSION	1	
12	90109-10550-00	BOLT (90109-10453-00)	1	
13	92990-10200-00	WASHER, PLAIN	1	
14	95303-10700-00	NUT	1	
15	91490-20025-00	PIN, SPLIT	1	
16	1W1-22128-00-00	COVER, THRUST 1	2	
17	90240-12059-00	PIN, CLEVIS	1	
18	92990-12600-00	WASHER, PLATE	1	
19	91401-30030-00	PIN, COTTER	1	

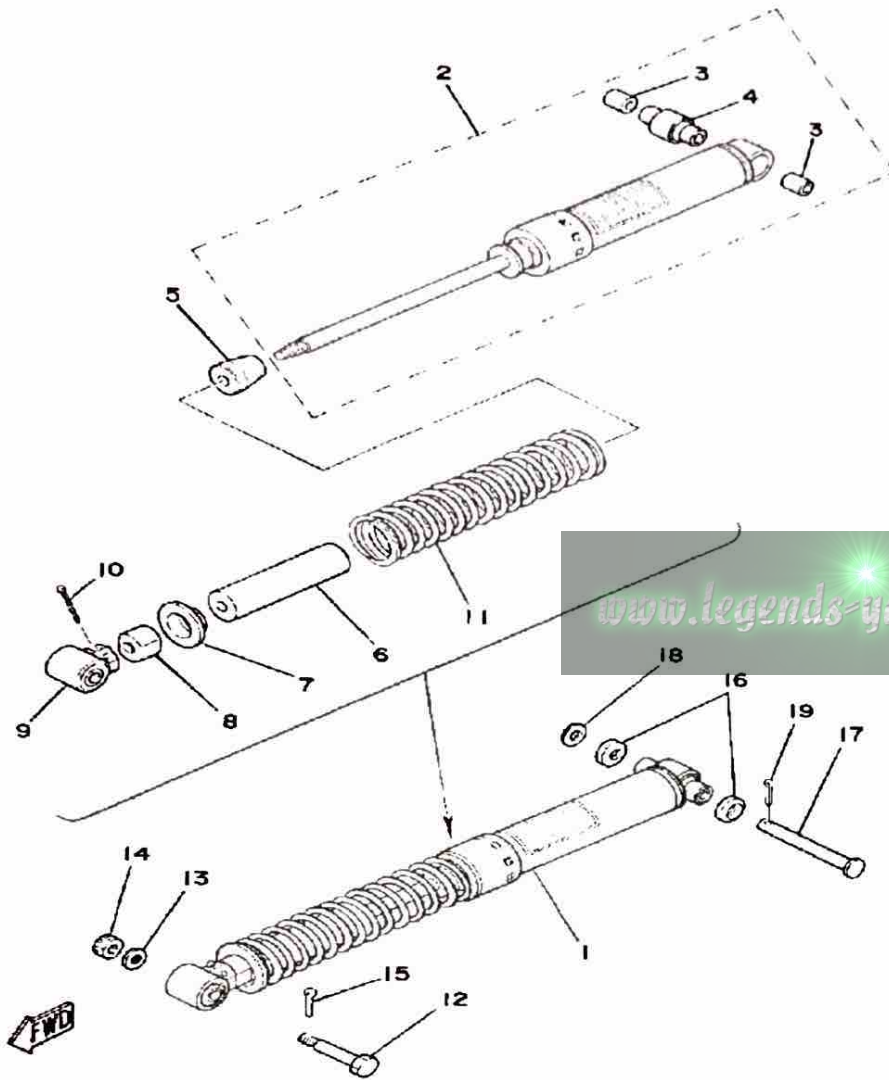

STEERING

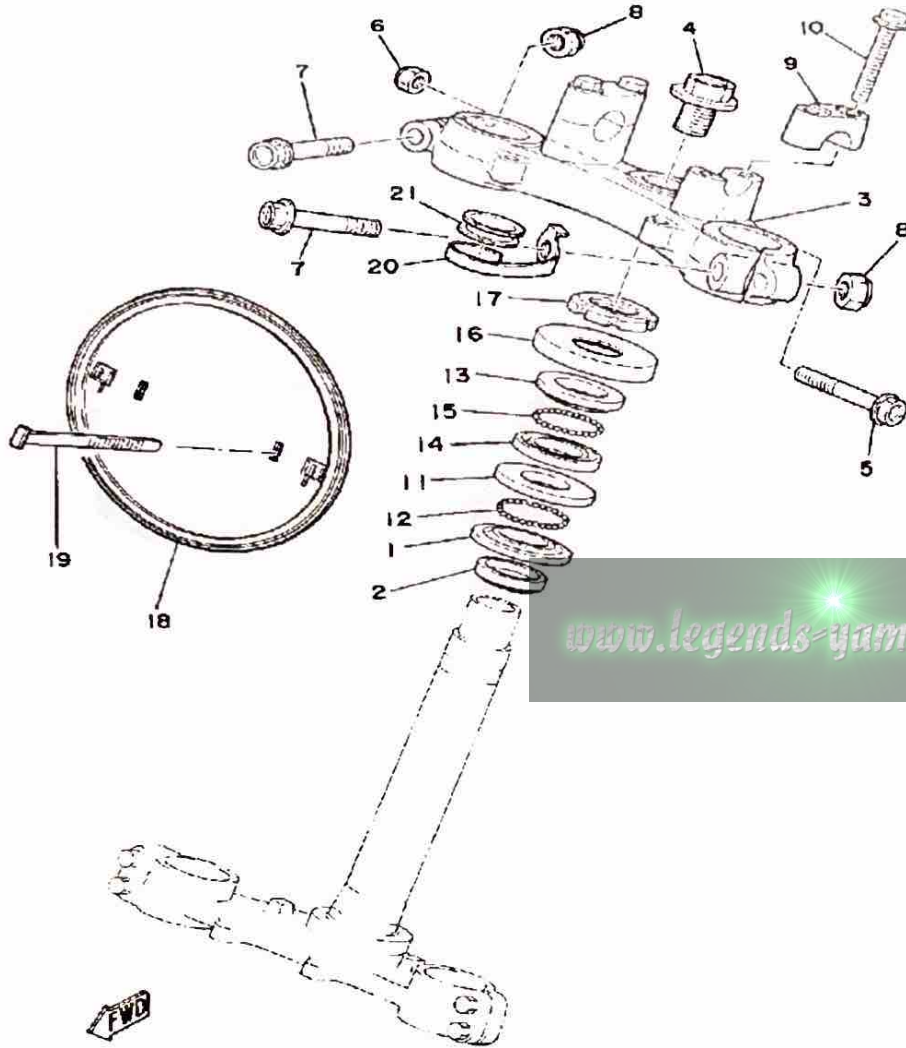

Ref. No.	Part Number	Description	Qty	Remarks
1	156-23411-00-00	RACE, BALL 1	1	
2	164-23462-00-00	SEAL, STEERING	1	
3	2N4-23435-00-98	CROWN, HANDLE	1	LOW GLOSS BLK
4	90105-14136-00	BOLT, WASHER BASED	1	
5	95811-08055-00	BOLT, FLANGE	1	
6	90185-08089-00	NUT, SELF-LOCKING	1	
7	95811-10060-00	BOLT, FLANGE	2	
8	90185-10060-00	NUT, SELF-LOCKING	2	
9	1E6-23441-00-00	HOLDER, HANDLE UPR	2	LOW GLOSS BLK
10	95811-08035-00	BOLT, FLANGE (95821-08035)	4	
11	156-23412-00-00	RACE, BALL 2	1	
12	93501-04011-00	BALL	19	
13	22F-23411-01-00	RACE, BALL 1	1	
14	22F-23412-01-00	RACE, BALL 2	1	
15	93503-16010-00	BALL	22	
16	10V-23416-01-00	COVER, BALL RACE 2	1	
17	90179-25033-00	NUT	1	
18	3R0-23485-00-00	PLATE, NUMBER	1	
19	2X4-23489-00-00	BAND	2	
20	2K5-23317-01-00	HOLDER, CABLE	1	
21	1W1-23389-00-00	GUIDE, CABLE	1	

FRONT FORK

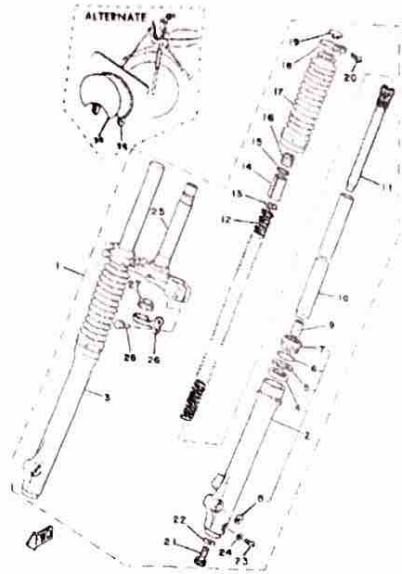

Ref. No.	Part Number	Description	Qty	Remarks
1	(3M2-23101-00-00)	FRONT FORK ASSEMBLY	1	
2	(3J0-23126-00-00)	TUBE, OUTER 1	1	
3	(3J0-23136-00-00)	TUBE, OUTER 2	1	
4	2K5-23145-00-00	. . OIL SEAL	2	
5	2K5-23146-00-00	. . WASHER, OIL SEAL	2	
6	15E-23153-00-00	. . RING, SNAP	2	
7	3Y6-23144-00-00	. . SEAL, DUST (2K5-23144-00)	2	
8	(2K5-23165-00-00)	WASHER, FELT	2	
9	2K5-23173-00-00	. SPINDLE, TAPER	2	
10	(3J0-23110-00-00)	INNER TUBE 1	2	
11	(3J0-23170-00-00)	CYLINDER, FRTRFK	2	
12	(3J0-23141-00-00)	SPRING, FRONT FORK	2	
13	256-23142-60-00	. SEAT, SPRING UPPER	2	
14	(3J0-23118-00-00)	SPACER	2	
15	146-23114-00-00	. GASKET	2	
16	1X0-23111-00-00	. BOLT, CAP	2	
17	2K5-23191-M0-00	. BOOT, FRONT FORK	2	
18	2K5-23192-00-00	. BAND	2	
19	1X0-23168-00-00	. CAP (2N4-23168-00)	2	
20	509-23194-L0-00	. SCREW, BOOT BAND	2	
21	278-23181-50-00	. BOLT, HEXAGON SOCKET HEAD	2	
22	509-23158-L0-00	. GASKET	2	
23	4H7-23119-00-00	. PLUG, DRAIN - (122-23119-01)	2	
24	122-23129-00-00	. GASKET, DRAIN PLUG	2	
25	(2N4-23340-00-33)	UNDER BRACKET	1	YAMAHA BLACK
26	1W1-23317-01-00	. HOLDER, CABLE	1	
27	1W1-23389-00-00	. GUIDE, CABLE	1	
28	5X6-23181-L0-00	. BOLT, HEX SCKT HEADSOCKET HEAD	4	

www.legends-yamaha-vehicles.com

CONTINUED ON NEXT FRAME ►

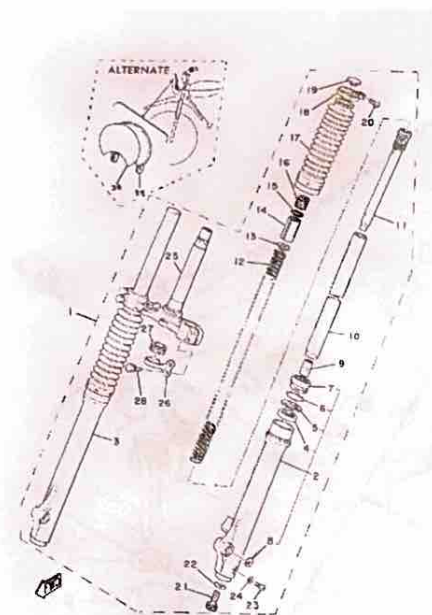

FRONT FORK

Ref. No.	Part Number	Description	Qty	Remarks
29	1W2-23485-00-00	PLATE, NUMBER	1	ALTERNATE PARTS
30	1W2-23395-00-00	EMBLEM	1	ALTERNATE PARTS

www.legends-yamaha-enduros.com

FUEL TANK

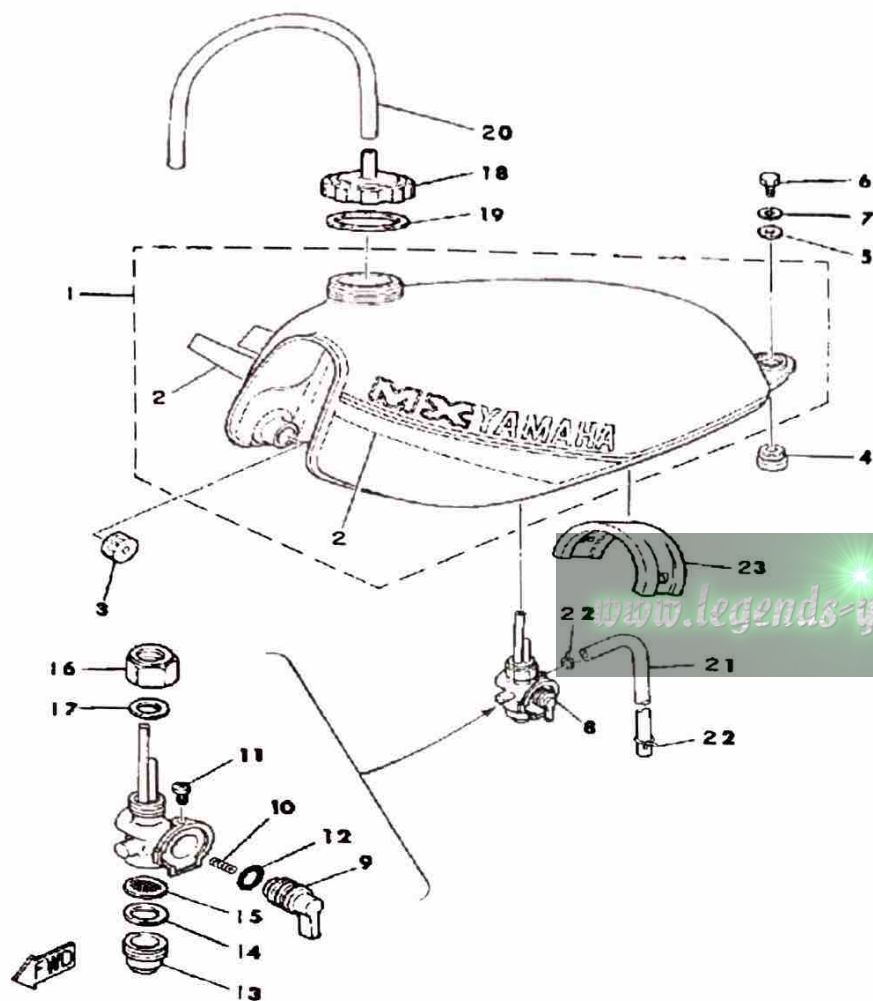

Ref. No.	Part Number	Description	Qty	Remarks
1	2N4-24110-Y0-X3	FUEL TANK	1	CLEAN WHITE
2	3M2-24240-10-00	. GRAPHIC SET	1	
3	278-24181-00-00	DAMPER, LOCATING 1	2	
4	90480-22231-00	GROMMET	2	
5	90201-06073-00	WASHER, PLATE	2	
6	97013-06012-00	BOLT	2	
7	92995-06100-00	WASHER, SPRING	2	
8	304-24500-12-00	FUEL COCK ASSEMBLY 1	1	
9	(357-24524-10-00)	LEVER, COCK	1	
10	(357-24529-10-00)	SPRING	1	
11	2N3-24535-00-00	. SCREW, LVR FITTING	1	
12	2N3-24528-00-00	. GASKET	1	
13	(357-24521-10-00)	CUP, FILTER	1	
14	357-24522-10-00	. GASKET	1	
15	357-24515-10-00	. NET, FILTER 2	1	
16	2N3-24531-00-00	. NUT	1	
17	2N3-24532-00-00	. GASKET	1	
18	2A6-24611-00-00	BODY, CAP	1	
19	1W1-24612-00-00	GASKET, CAP	1	
20	90445-09115-00	HOSE	1	
21	90445-09089-00	HOSE	1	
22	90467-08003-00	CLIP	2	
23	2A6-24182-00-00	DAMPER, LOCATING 2	1	

SEAT

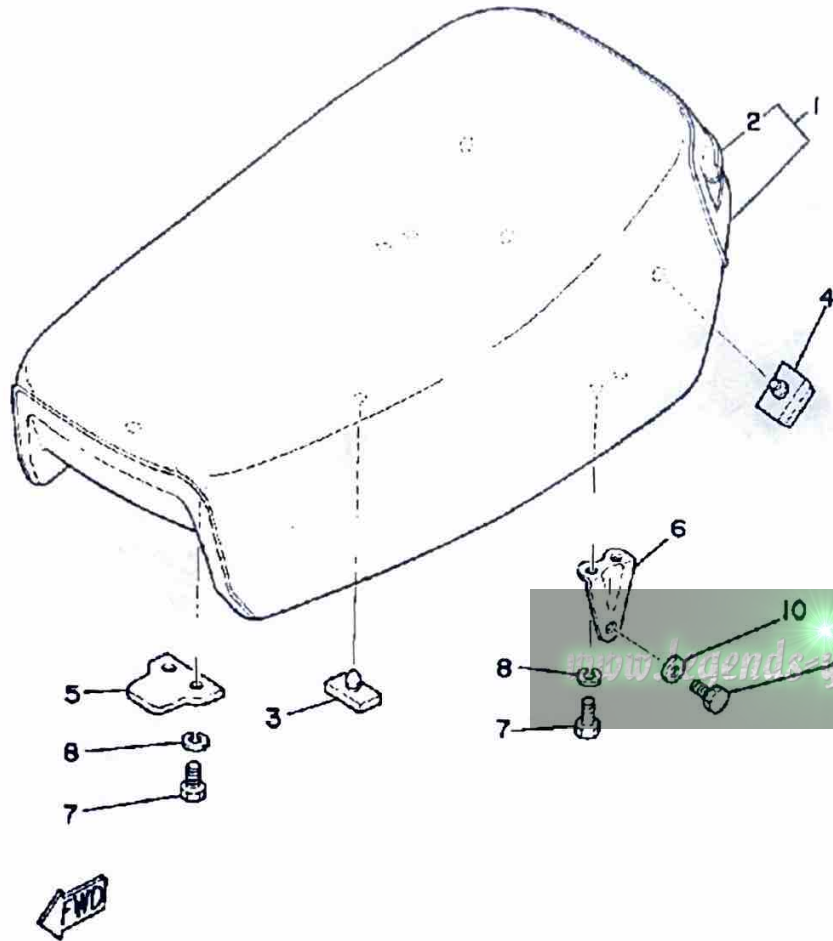

Ref. No.	Part Number	Description	Qty	Remarks
1	2N4-W2473-00-00	SEMI-DBL-SEAT ASSEMBLY (2N4-24770-90)	1	
2	3M2-24771-00-00	. COVER, SM-DBL SEAT	1	
3	509-24724-00-00	DAMPER, SEAT	4	
4	214-24724-00-00	DAMPER, SEAT	2	
5	1M1-24748-00-00	BRACKET, SEAT	1	
6	2A6-24738-00-00	BRACKET, SEAT	2	
7	97013-06012-00	BOLT	6	
8	92995-06100-00	WASHER, SPRING	6	
9	97313-08012-00	BOLT	2	
10	92901-08600-00	WASHER	2	

FRONT WHEEL

Ref. No.	Part Number	Description	Qty	Remarks
1	248-25111-00-98	HUB, FRONT	1	LOW GLOSS BLK
2	93306-30103-00	BEARING (B6301Z)	1	
3	90560-12261-00	SPACER	1	
4	109-25315-00-00	FLANGE, SPACER	1	
5	93102-18008-00	OIL SEAL	1	
6	93306-30103-00	BEARING (B6301Z)	1	
7	2K5-25121-01-98	PLATE, BRAKE SHOE	1	LOW GLOSS BLK
8	22F-W2534-00-00	BRAKESHOE SET	2	
9	90506-16150-00	SPRING, TENSION (102-25333-00)	2	
10	401-25155-11-00	LEVER, CAMSHAFT 1 (401-25155-00)	1	
11	90101-06278-00	BOLT	1	
12	95380-06600-00	NUT	1	
13	122-25351-02-00	CAMSHAFT	1	
14	94416-21223-00	RIM 1.60X 1	1	
15	3M2-25104-00-00	SPOKE SET, FRONT	1	
16	(94127-21550-00)	CS 275X21 C-755 1	1	
17	(94227-21144-00)	TUBE	1	
18	94330-21084-00	BAND, RIM (3.00-21)	1	
19	1T1-25194-00-00	SPACER, BEAD	1	
20	90387-12265-00	COLLAR (183-25183-00)	1	
21	2K5-25118-00-00	COVER, HUB DUST	1	
22	353-25381-00-00	AXLE, WHEEL	1	
23	90171-10004-00	NUT, CASTLE	1	
24	91490-20020-00	PIN, COTTER	1	

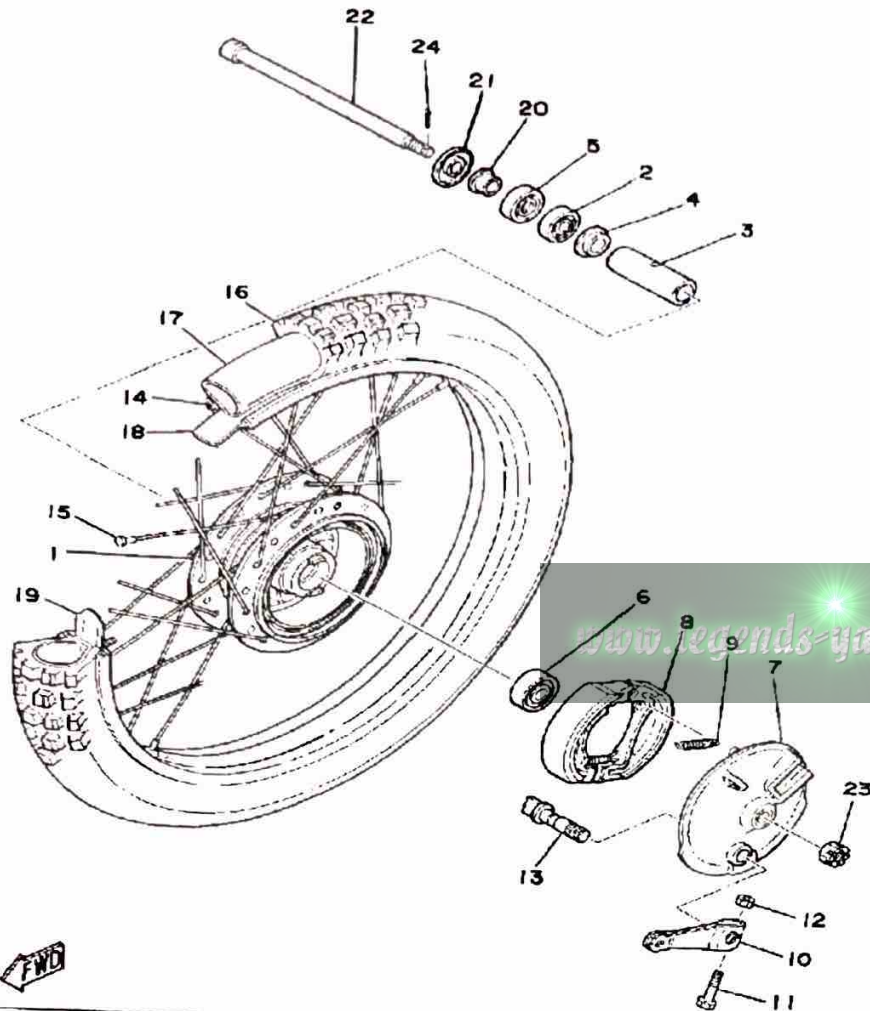

Tire Size (Nominal Pressure)	F:2.75-21 (0.8 kg/cm ² /13 psi) R:3.50-18 (1.1 kg/cm ² /16 psi)
Front Axle Nut	10 x 1.25: 4.0 m-kp
Front Axle Holder Nut	10

REAR WHEEL

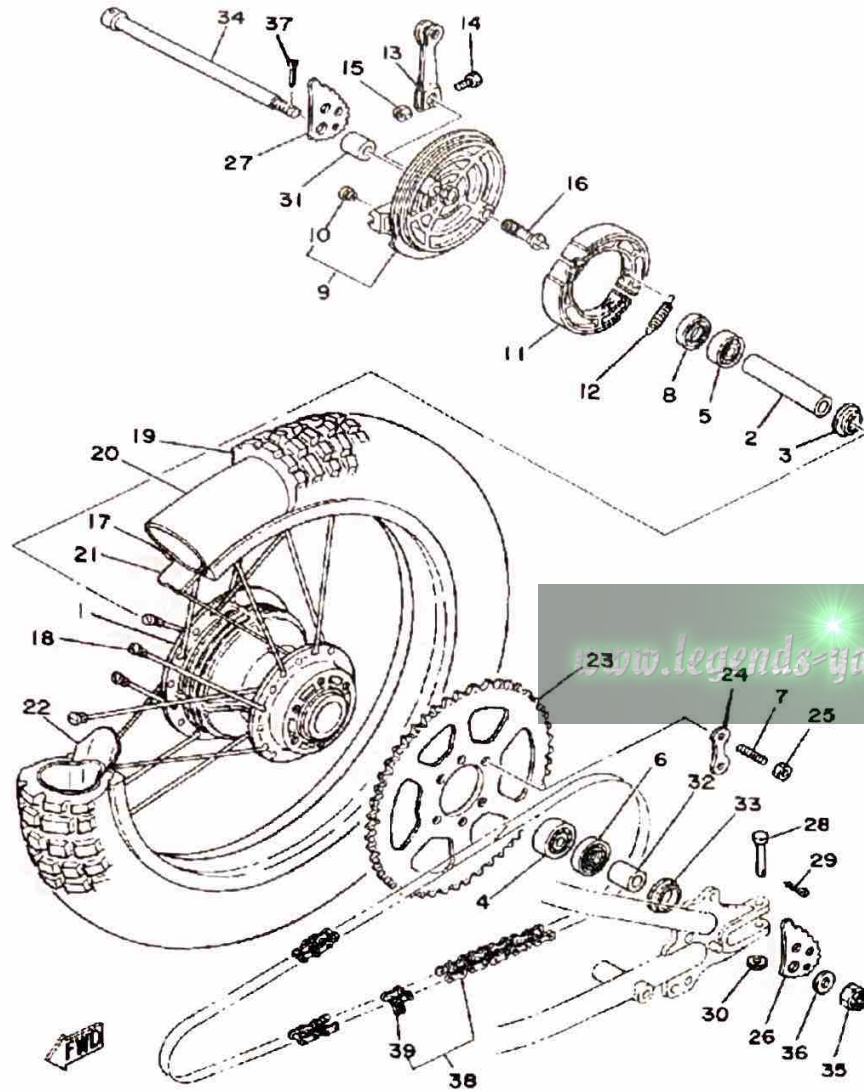

Ref. No.	Part Number	Description	Qty	Remarks
1	1W1-25311-00-98	HUB, REAR	1	LOW GLOSS BLK
2	90560-15313-00	SPACER	1	
3	146-25115-00-00	FLANGE, SPACER 1	1	
4	93306-30202-00	BEARING	1	
5	93306-20204-00	BEARING (B6202Z)	1	
6	93106-26005-00	OIL SEAL	1	
7	90116-10221-00	BOLT, STUD	6	
8	93104-22018-00	OIL SEAL	1	
9	99999-02024-00	BRAKE SHOE PLT ASSEMBLY (2A6-25026-00-98)BRAKE SHOE PLAT	1	LOW GLOSS BLK
10	90480-10068-00	GROMMET	1	
11	437-W2536-00-00	BRAKESHOE SET-2PCS	2	
12	90506-17328-00	SPRING, TENSION	2	
13	1E2-25155-00-00	LEVER, CAMSHAFT 1	1	
14	90101-06278-00	BOLT	1	
15	95380-06600-00	NUT	1	
16	2RH-25351-00-00	CAMSHAFT	1	
17	94418-18171-00	RIM 1.85X 8	1	
18	401-25304-00-00	SPOKE SET, REAR	1	
19	(94135-18551-00)	CS 350X18 C-755 1	1	
20	94235-18085-00	TUBE	1	
21	94325-18043-00	BAND, RIM	1	
22	1T2-25394-00-00	SPACER, BEAD	1	
23	18L-25449-20-00	SPROCKET, DRVN 49T	1	U.R.
	1X0-25445-10-33	SPROCKET, DRVN 45T	1	U.R.
	2N0-25447-10-00	SPOCKET, DRVN 47T	1	U.R.
24	1G8-25412-00-00	WASHER	3	
25	95701-10500-00	NUT, FLANGE (95702-10500)	6	

CONTINUED ON NEXT FRAME ►

REAR WHEEL

Ref. No.	Part Number	Description	Qty	Remarks
26	1W2-25388-01-00	PULLER, CHAIN 1	1	
27	1W2-25389-01-00	PULLER, CHAIN 2	1	
28	91701-06042-00	PIN, CLEVIS	2	
29	91490-20020-00	PIN, COTTER	2	
30	92901-06600-00	WASHER	2	
31	90387-15524-00	COLLAR	1	
32	90387-15524-00	COLLAR	1	
33	401-25367-00-00	COVER, HUB DUST	1	
34	5X3-25381-00-00	AXLE, WHEEL (2A6-25381-00-00)	1	
35	90171-14020-00	NUT, CASTLE	1	
36	90201-15238-00	WASHER, PLATE	1	
37	91401-30030-00	PIN, COTTER	1	
38	94580-33118-00	DID428DS-118L (94580-15118)	1	
39	94680-15001-00	JOINT CHAIN	1	

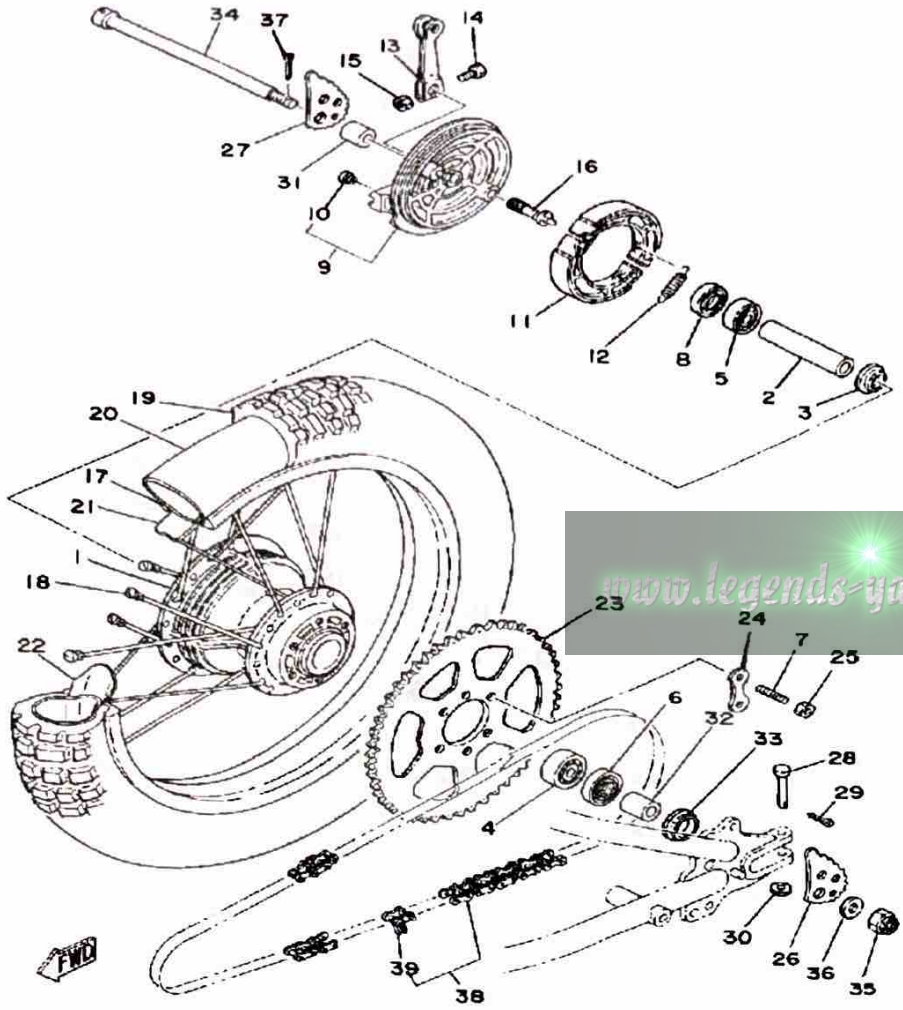

HANDLEBAR - CABLE

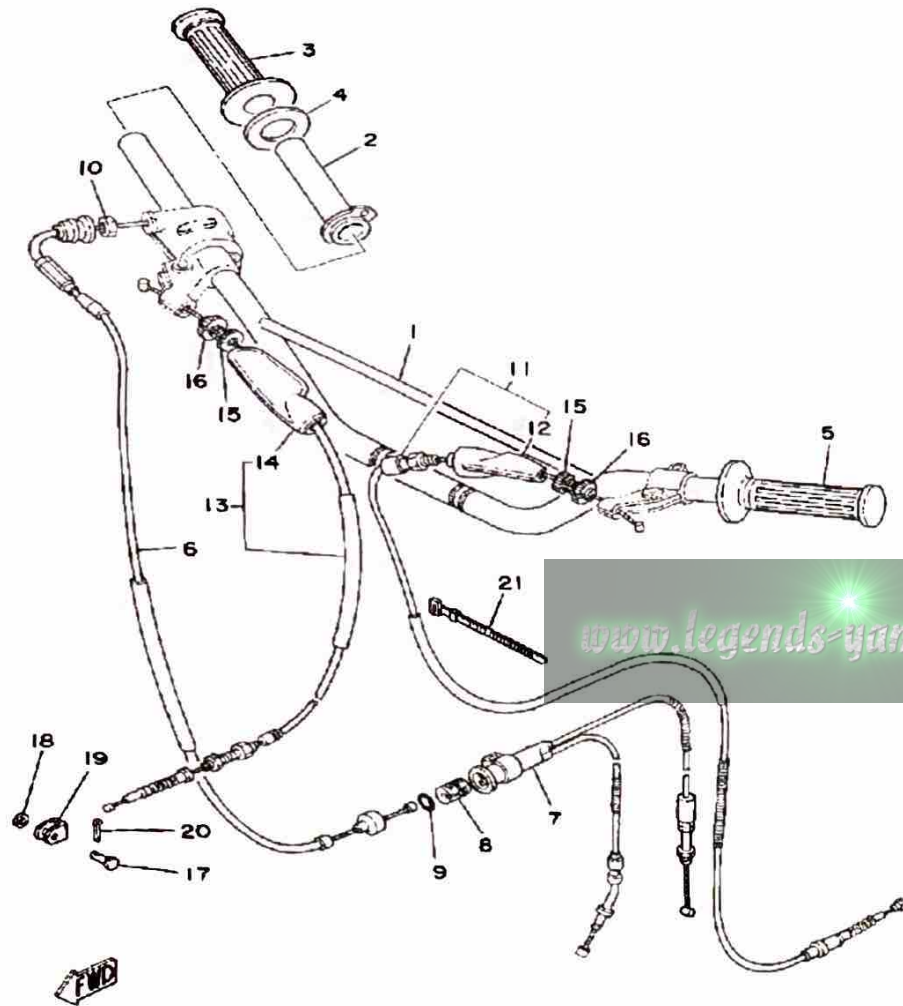

Ref. No.	Part Number	Description	Qty	Remarks
1	2A8-26111-00-00	HANDLEBAR	1	
2	434-26243-00-00	TUBE, THROTTLE GUIDE	1	
3	1A0-26242-01-00	GRIP (RIGHT)	1	
4	1M1-26249-01-00	RING, LEAF	1	
5	1E6-26241-00-00	GRIP LH	1	
6	2A6-26311-00-00	CABLE, THROTTLE 1	1	
7	2A6-26312-00-00	CABLE, THROTTLE 2	1	
8	1M1-26263-00-00	PIECE, CONNECTING	1	
9	93210-10118-00	O-RING	1	
10	90170-10038-00	NUT, HEXAGON	1	
11	2A6-26335-01-00	CABLE, CLUTCH	1	
12	382-26372-01-00	COVER, HANDLE LEVER	1	
13	2K5-26341-00-00	CABLE, BRAKE	1	
14	382-26372-01-00	COVER, HANDLE LEVER	1	
15	90123-08046-00	BOLT	2	
16	90179-08148-00	NUT	2	
17	90240-08013-00	PIN, CLEVIS	1	
18	90201-08083-00	WASHER, PLATE	1	
19	156-26347-00-00	JOINT, CABLE	1	
20	91490-20020-00	PIN, COTTER	1	
21	437-83936-11-00	BAND, SWITCH CORD	1	

STA.

FOOTREST

Ref. Par.
No. Number

Description Qty Remarks

1	3M2-27211-00-33		1	
2	90508-32354-00	SPR.	1	
3	90201-14212-00	WASH.	1	
4	93430-10015-00	CIRCLIP, L	1	
5	1W2-27231-00-00	ROD, BRAKE	1	
6	90240-06006-00	PIN, CLEVIS		
7	92990-06200-00	WASHER		
8	91401-25020-00	PIN, COTTER		
9	90501-10245-00	SPRING, COMPRESSION		
10	90249-12008-00	PIN		
11	90179-06411-00	NUT	1	
12	1W1-27311-10-00	STAND, SIDE	1	
13	90507-29008-00	SPRING, TENSION	1	
14	90109-103A1-00	BOLT	1	
15	90185-10037-00	NUT, SELF-LOCKING	1	
16	22W-27411-01-90	FOOTREST 1	1	
17	22W-27421-01-90	FOOTREST 2	1	
18	90508-20023-00	SPRING, TORSION	2	
19	91701-08038-00	PIN, CLEVIS	2	
20	91401-25020-00	PIN, COTTER	2	
21	92901-08600-00	WASHER	2	
22	97011-06020-00	BOLT	1	
23	95380-06700-00	NUT	1	

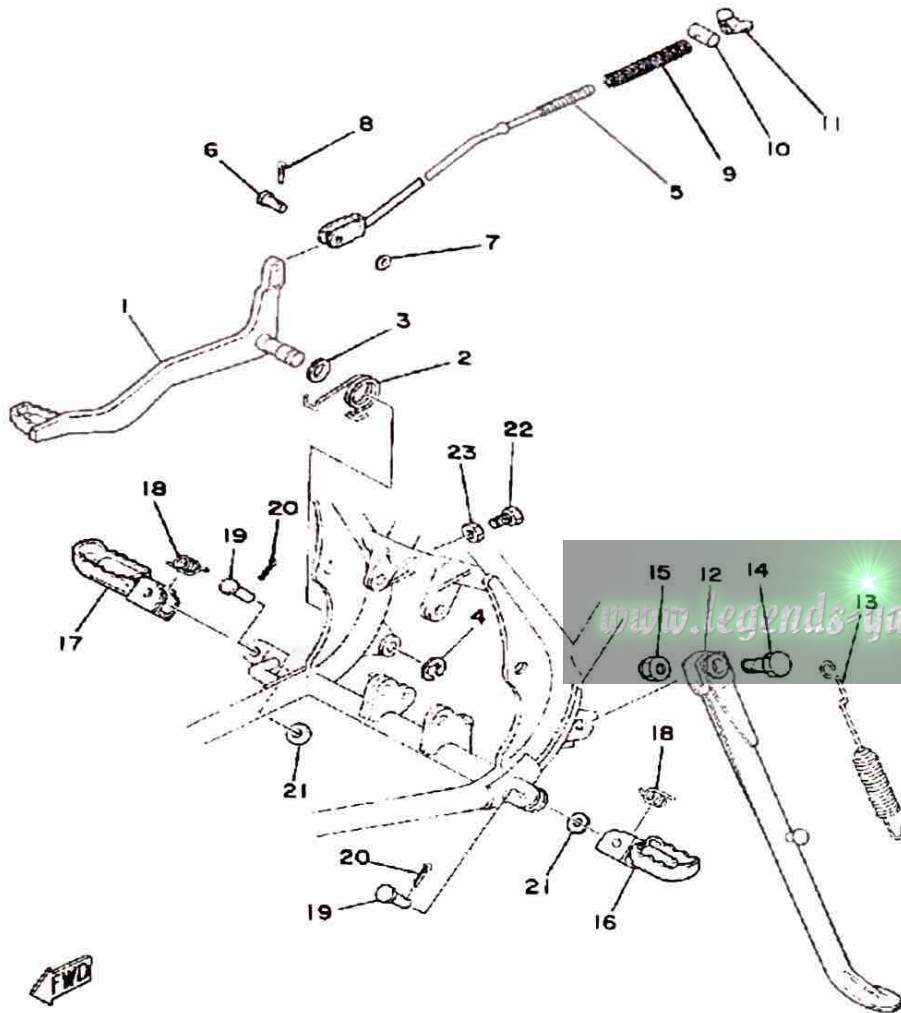

ELECTRICAL 1

Ref. No.	Part Number	Description	Qty	Remarks
1	5G4-82310-40-00	IGNITION COIL ASSEMBLY (J17-82310-21)	1	
2	98580-06020-00	SCREW	2	
3	92995-06100-00	WASHER, SPRING	2	
4	81E-82370-20-00	PLUG CAP ASSEMBLY	1	
5	(3M2-82590-01-00)	WIRE HARNESS ASSEMBLY	1	
6	437-83936-01-00	BAND, SWITCH CORD	4	

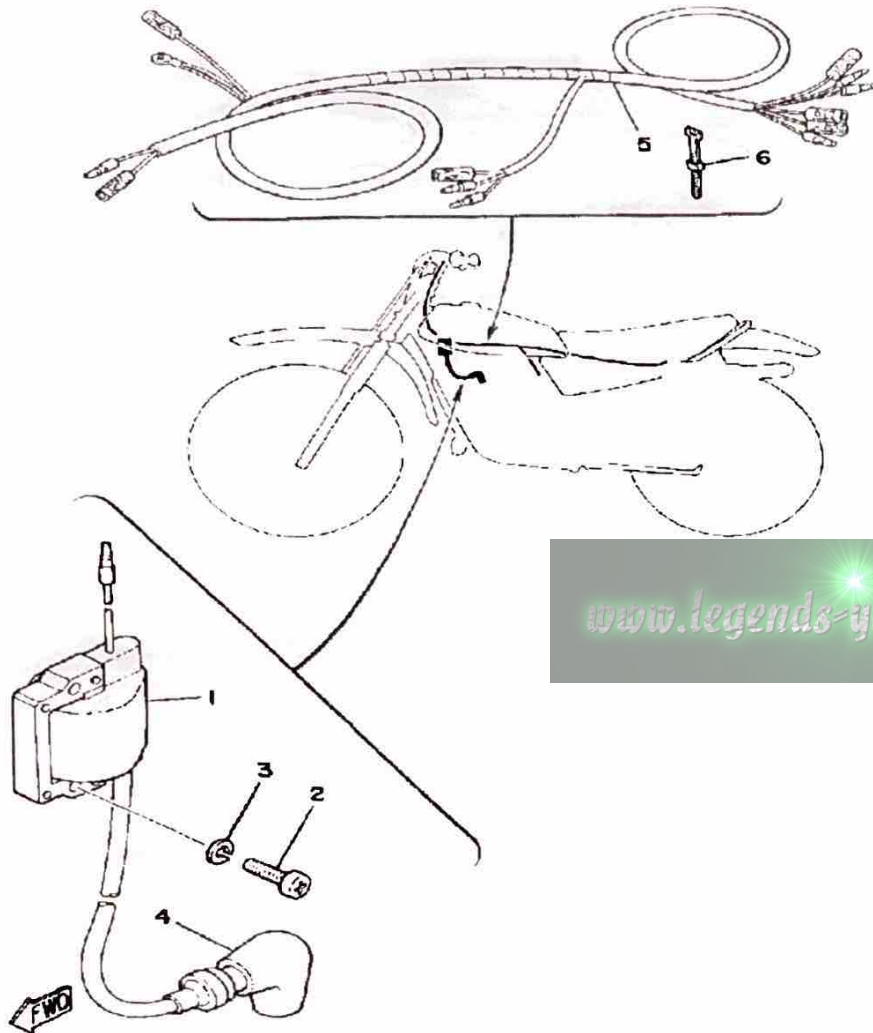

www.legends-yamaha-enduros.com

HANDLE SWITCH - LEVER

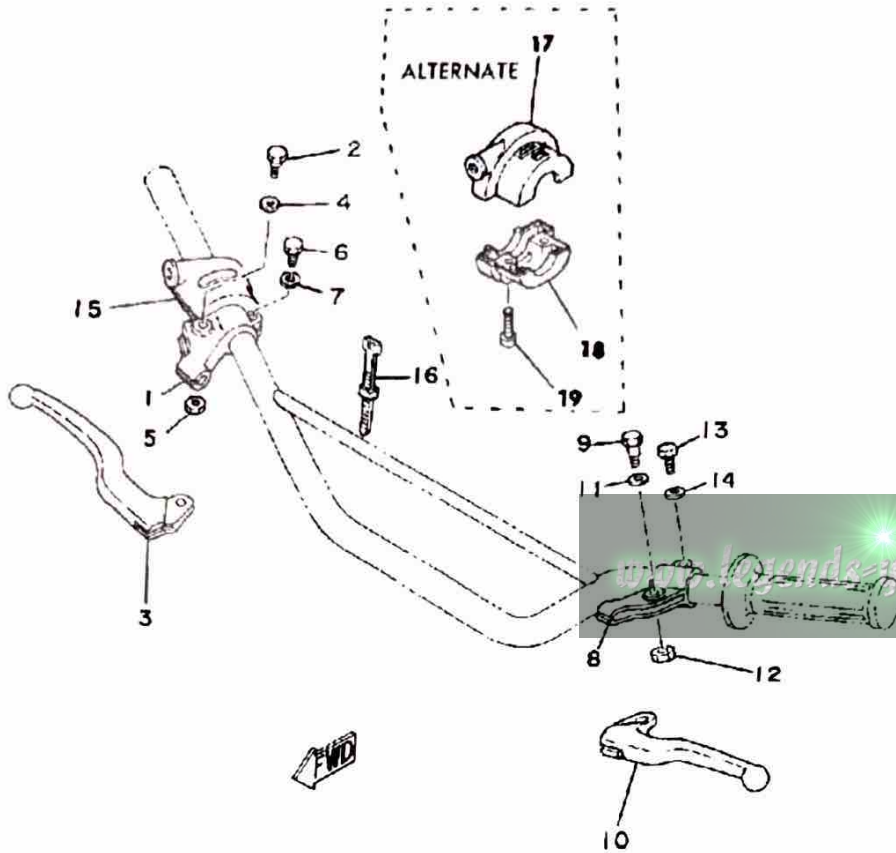

Ref. No.	Part Number	Description	Qty	Remarks
1	516-82921-30-00	HOLDER, LEVER 2	1	
2	90109-06797-00	BOLT	1	
3	23X-83922-00-00	LEVER 2	1	
4	90201-08083-00	WASHER, PLATE	1	
5	95601-06100-00	NUT, U	1	
6	97003-06022-00	BOLT, HEXAGON (97301-06022)	1	
7	92995-06100-00	WASHER, SPRING	1	
8	214-82911-01-00	HOLDER, LEVER 1	1	
9	90109-06797-00	BOLT	1	
10	23X-83912-00-00	LEVER 1	1	
11	90201-08083-00	WASHER, PLATE	1	
12	95601-06100-00	NUT, U	1	
13	97003-06022-00	BOLT, HEXAGON (97301-06022)	1	
14	92995-06100-00	WASHER, SPRING	1	
15	(2X6-83976-00-98)	SWITCH, HANDLE 1	1	
16	437-83936-01-00	BAND, SWITCH CORD	2	
17	3M2-26281-00-00	CAP, GRIP UPPER	1	
18	437-26282-02-00	CAP, GRIP LOWER	1	
19	98580-05020-00	SCREW, PAN HEAD	2	

LIGHTING KIT

Ref. No.	Part Number	Description	Qty	Remarks
1	(ACC-01100-61-00)	MX175 LIGHTING KIT	1	
2	(3M2-85533-20-00)	UNAVAILABLE IN PRICE BOOK	1	
3	(3M2-85513-20-00)	COIL, LIGHTING 1	1	
4	(3M2-85515-21-00)	LEAD WIRE ASSEMBLY	1	
5	98511-04030-00	SCREW, PAN HEAD	2	
6	92901-04100-00	WASHER, SPRING	2	
7	3M2-82590-90-00	WIRE HARNESS ASSEMBLY ..	1	
8	1W2-83973-00-98	SWITCH, HANDLE 3	1	
9	98580-05020-00	SCREW, PAN HEAD	2	
10	437-83936-01-00	BAND, SWITCH CORD	2	
11	(1W2-84110-60-00)	UNAVAILABLE IN PRICE BOOK	1	N/A
12	(1W2-84115-60-00)	RIM, HEADLIGHT	1	
13	1W2-84144-60-00	COVER, HEADLIGHT	1	
14	3R8-84120-60-00	LENS ASSEMBLY	1	
15	527-84114-09-XX	BULB, HL 6V25/25W	1	
16	1W2-84112-60-00	SOCKET	1	
17	1W2-84324-60-00	SPRING, REFLECTOR	4	
18	98580-05016-00	SCREW, PAN HEAD	1	
19	92990-05100-00	WASHER, SPRING	1	
20	1W2-84130-60-00	BODY ASSEMBLY, HEADLIGHT	1	LOW GLOSS BLACK
21	(1W2-84145-60-00)	COLLAR, BODY FTNG	2	
22	1L9-84338-60-00	COLLAR, BODY FTNG	2	
23	(3M2-84118-00-00)	STAY, HEADLIGHT 1	1	
24	(3M2-84119-00-00)	STAY, HEADLIGHT 2	1	
25	98580-06020-00	SCREW	1	
26	92995-06100-00	WASHER, SPRING	1	
27	92901-06600-00	WASHER	1	
28	98580-06020-00	SCREW	1	
29	92995-06100-00	WASHER, SPRING	1	

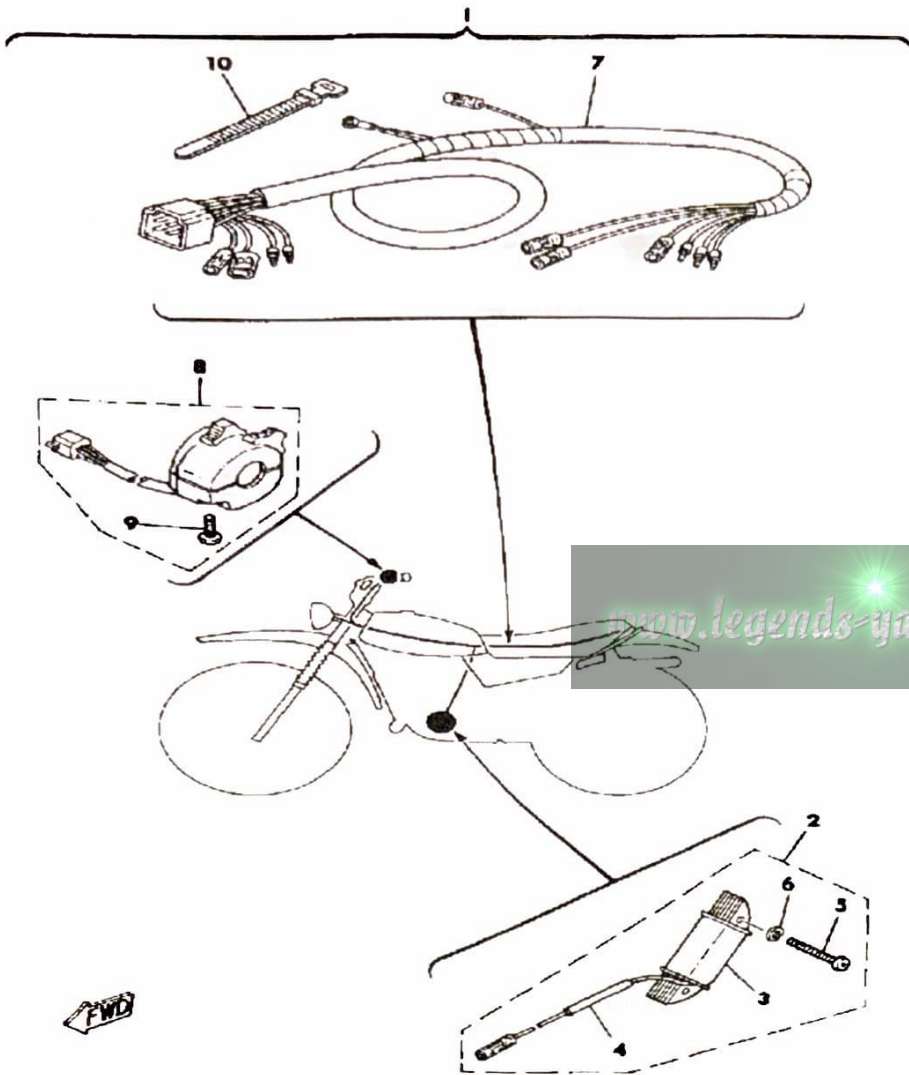

LIGHTING KIT CONTINUED ON GRIDS E2 & E3

CONTINUED ON NEXT FRAME ►

LIGHTING KIT

Ref. No.	Part Number	Description	Qty	Remarks
30	92901-06600-00	WASHER	1	
31	1W2-84143-00-00	DAMPER, HDLT STAY	2	
32	92990-08100-00	WASHER	4	
33	92901-08600-00	WASHER	2	
34	95303-08800-00	NUT (CROWN) (95301-08800) .	2	
35	95333-08600-00	NUT	2	
36	434-84500-64-00	TAILLIGHT ASSEMBLY	1	
37	434-84521-69-00	LENS, TAILLIGHT	1	
38	434-84515-61-00	RIM, TAILLIGHT	1	
39	122-84514-30-00	BULB	1	
40	434-84517-61-00	CORD, TAILLIGHT	1	
41	434-84522-62-00	WASHER	2	
42	(434-84524-62-00)	SCREW, LENS FITTING	2	
43	434-84519-64-00	BRACKET, TAILLIGHT	1	
44	434-84500-64-00	TAILLIGHT ASSEMBLY	1	
45	(434-84557-60-00)	COLLAR		
46	1W2-84525-00-00	WASHER, SPECIAL	1	
47	92990-05100-00	WASHER, SPRING	2	
48	95380-05600-00	NUT	2	
49	90462-05005-00	CLAMP	2	

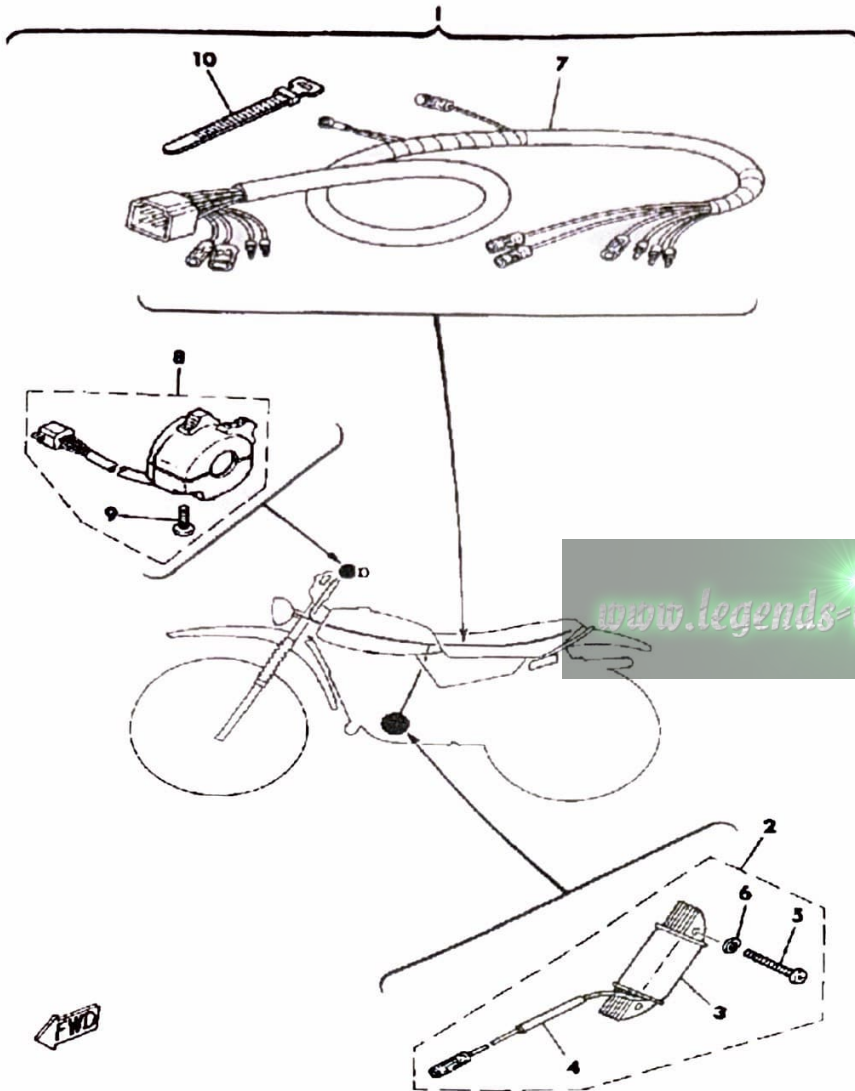

LIGHTING KIT CONTINUED ON GRIDS E2 & E3

MX175H

1981 SERVICE DATA

MODEL - IBM I.D. NUMBER	MX175H	3M2
Initial Engine Number / Frame Number	3M2 200101 / 3M2-200101	
Basic Color(s)	Clean White	
Fuel Type / Fuel Tank Capacity / Reserve Capacity	Regular / 6.8 Lit. (1.8 Gal.) / 0.9 Lit. (0.2 Gal.)	
Dry Vehicle Weight	91 kg (200 lbs.)	
ENGINE TYPE	2-Stroke, Air-Cooled, Reed Valve	
Bore / Stroke / Number Cylinders / Displacement (cc)	66mm / 50mm / 1 / 171cc	
Compression Ratio / Compression Pressure Min~Max	6.8:1 / \emptyset	
Piston Skirt Clearance New / Max	0.040 ~ 0.045mm / 0.1mm	
Ring End Gap Top / 2nd / 3rd	0.3 ~ 0.5mm / 0.3 ~ 0.5mm / \emptyset	
Valve Clearance (Cold) Intake / Exhaust	\emptyset	
Oil Pressure Hot / rpm	\emptyset	
Oiling System	Autolube	
Capacity: Dry	1.0 Lit. (1.0 Qt.)	
Oil and Filter Change	\emptyset	
Oil Change	\emptyset	
Lubricant: Temp. Above 5°C (40°F)	Yamalube 2* or Equivalent	
Temp. Below 15°C (60°F)	Yamalube 2* or Equivalent	
AUTOLUBE - Min Stroke / Color Code	0.20 ~ 0.25mm / Gray	
Minimum Output @ 200 Cycles	0.50cc	
Maximum Output @ 200 Cycles	5.13cc	
CARBURETOR - AMr. / Type / I.D. Number	Mikuni / VM24SS / 3M2-00	
Main Jet / Pilot Jet	130 / 27.5	
Needle Jet / Jet Needle-Clip Position	0.2 / 4L6-3	
Slide Cutaway or Throttle Valve	3.0	
Float Level / Fuel Level	21.0mm \pm 1.0mm / NA	
Idle rpm	\emptyset	
Max CO* / Max HC* / Set CO	\emptyset	
SUSPENSION		
Front Forks: Oil Type / Level / Qty	10 Wt. Fork Oil* / \emptyset / 179cc	
Gas Pressure	\emptyset	
Spring Length Std	453.5mm	
Monoshock: Oil Type / Qty	Not Rebuildable	
Gas Pressure	15 kg/cm ²	
Minimum Brake Lining Thickness	Front: 2mm Rear: 2mm	
Tire Size (Nominal Pressure)	F:2.75-21 8.9 kg/cm ² /13 psi R:3.50-18 (1.1 kg/cm ² /16 psi)	
TRANSMISSION - Oil Type/Qty Chg/Qty Reassemble	SAE 10W30 SE / 650cc / 750cc	
Primary Drive Type / Teeth / Ratio	Helical Gear / 71-22 / 3.227	
Secondary Drive Type / Teeth / Chain	Chain / 49-15 / DID428DSM-118L	
Clutch Friction Plate Thickness Std ~ Min	3.0 ~ 2.8mm	
Clutch Spring Length Std ~ Min	33.0 ~ 32.0mm	
Middle Gear Case Capacity	\emptyset	
Final Gear Case Capacity	\emptyset	
Gear Case Lubricant: Temp. Above 5°C (40°F)	\emptyset	
Temp. Below 15°C (60°F)	\emptyset	
All Weather Conditions	\emptyset	

SERVICE COPY	SER MGR	MECH	MECH	MECH	BINDER
OFFICE COPY	GEN MGR	SALES	PARTS	BINDER	PAGE 1 OF 2

CHARGING SYSTEM	Flywheel Magneto / Single Phase / Half Wave
Battery: Model / Specific Gravity / Charge Rate	\emptyset
Maximum Output	\emptyset
TROUBLESHOOTING	
Field Coil Color Code / Ω	\emptyset
Charge Coil Color Code / Ω	\emptyset
IGNITION SYSTEM	Capacitor-Discharge Ignition
Ignition Timing	1.8mm BTDC
Spark Plug Type	NGK B8ES
Spark Plug Gap / Torque / Cap Ω	0.6 ~ 0.8mm / 2.0 m·kg / 5K Ω \pm 10%
Point Gap / Condenser Capacitance	\emptyset
TROUBLESHOOTING	
Ignition Coil Test Gap / Primary Ω / Secondary Ω	6mm / 1.0 Ω \pm 10% / 5.9K Ω \pm 20%
Pulser Coil or Pickup Coil Color Code / Ω	Wht-Red ~ Blk / 10 Ω \pm 10%
Source Coil Color Code / Ω	Bm-Blk / 300 Ω \pm 10%
LIGHTING SYSTEM	
Headlight / Taillight / Signal Rating	\emptyset
TROUBLESHOOTING	
Lighting Coil Color Code / Ω	\emptyset
TORQUE VALUES	
Front Axle Nut	10 x 1.25: 4.0 m·kg
Front Axle Holder Nut	\emptyset
Rear Axle Nut	14 x 1.5: 8.5 m·kg
Rear Axle Pinch Bolt	\emptyset
Clutch Nut	14 x 1.5: 5.0 m·kg
Drain Plug	12 x 1.5: 2.5 m·kg
Cylinder Head Cover	\emptyset
Cylinder Head:	Nut 8 x 1.25: 2.5 m·kg Stud 8 x 1.25: 2.5 m·kg
Engine Mounting Bolts: Front	8 x 1.25: 2.5 m·kg
Rear, Upper	8 x 1.25: 2.5 m·kg
Rear, Lower	10 x 1.25: 4.0 m·kg

\emptyset = Does Not Apply To This Model
NA = Information Not Available

*Available From Yamaha Parts Distributors Inc.
*For Diagnostic Use Only

CHARGING SYSTEM	Flywheel Magneto / Single Phase / Half Wave
Battery: Model / Specific Gravity / Charge Rate	Ø
Maximum Output	Ø
TROUBLESHOOTING	
Field Coil Color Code / Ω	Ø
Charge Coil Color Code / Ω	Ø
IGNITION SYSTEM	Capacitor-Discharge Ignition
Ignition Timing	1.8mm BTDC
Spark Plug Type	NGK BBES
Spark Plug Gap / Torque / Cap Ω	0.6 ~ 0.8mm / 2.0 m·kg / 5K Ω ± 10%
Point Gap / Condenser Capacitance	Ø
TROUBLESHOOTING	
Ignition Coil Test Gap / Primary Ω / Secondary Ω	Ømm / 1.0 Ω ± 10% / 5.9K Ω ± 20%
Pulser Coil or Pickup Coil Color Code / Ω	Whi-Red ~ Blk / 16 Ω ± 10%
Source Coil Color Code / Ω	Brn-Blk / 300 Ω ± 10%
LIGHTING SYSTEM	
Headlight / Taillight / Signal Rating	Ø
TROUBLESHOOTING	
Lighting Coil Color Code / Ω	Ø
TORQUE VALUES	
Front Axle Nut	10 x 1.25: 4.0 m·kg
Front Axle Holder Nut	Ø
Rear Axle Nut	14 x 1.5: 8.5 m·kg
Rear Axle Pinch Bolt	Ø
Clutch Nut	14 x 1.5: 5.0 m·kg
Drain Plug	12 x 1.5: 2.5 m·kg
Cylinder Head Cover	Ø
Cylinder Head	Nut 8 x 1.25: 2.5 m·kg Stud 8 x 1.25: 2.5 m·kg
Engine Mounting Bolts: Front	8 x 1.25: 2.5 m·kg
Rear, Upper	8 x 1.25: 2.5 m·kg
Rear, Lower	10 x 1.25: 4.0 m·kg

Ø = Does Not Apply To This Model
 NA = Information Not Available

*Available From Yamaha Parts Distributors Inc.
 *For Diagnostic Use Only

www.legends-yamaha-enduros.com