



YAMAHA

YZ60J

**OWNER'S
SERVICE MANUAL**

www.legends-yamaha-enduros.com

Some data in this manual may become outdated due to improvements made to this model in the future. If there is any question you have regarding this manual or your machine, please consult your Yamaha dealer.

This Owner's Service Manual is included to provide basic information for operation and maintenance.

Additional information regarding major repairs, such as crankcase disassembly, can be found within the GT80E/GTMXE Service Manual (2F4-28197-10) and various other information and training manuals available from your Authorized Yamaha Dealer.

INTRODUCTION

Congratulations on your purchase of the Yamaha YZ60J. This model represents the product of many years of Yamaha experience in the production of fine sporting, touring, and pace-setting racing machines. You can now appreciate the high degrees of craftsmanship and reliability that have made Yamaha a leader in these fields.

PLEASE READ THIS MANUAL CAREFULLY AND COMPLETELY BEFORE OPERATING YOUR NEW MACHINE. This manual will provide you with a good basic understanding of the features, operation, and basic maintenance and inspection items of this vehicle. If you have any questions regarding the operation or maintenance of your machine, please consult your Yamaha dealer.

Particularly important information is distinguished in this manual by the following notations:

NOTE: A NOTE provides key information to make procedures easier or clearer.

CAUTION: A CAUTION indicates special procedures that must be followed to avoid damage to the machine.

WARNING: A WARNING indicates special procedures that must be followed to avoid injury to a machine operator or person inspecting or repairing the machine.

YZ60J OWNER'S SERVICE MANUAL
© 1981 Yamaha Motor Corporation, U.S.A.
1st. Edition, June 1981
All rights reserved. Any reprinting or
unauthorized use without the written
permission of Yamaha Motor Corporation,
U.S.A., is expressly prohibited

P/No. LIT-11626-03-19

WARNING:

- READ OWNER'S MANUAL CAREFULLY BEFORE OPERATING.
- USE MIXED GAS.
- OPERATOR ONLY. NO PASSENGERS. WEIGHT LIGHT 50 kg (110 lb)
- DO NOT TOUCH ANY MOVING OR HEATED AREAS.
- INSPECTION REQUIRED BEFORE RIDING. REFER TO PAGE 5.
- WEAR HELMET AND SUITABLE PROTECTIVE CLOTHING.
- ADULT SUPERVISION REQUIRED WHEN CHILDREN OPERATE THIS VEHICLE.
- COMPLETION USE ONLY.

IMPORTANT NOTICE

This vehicle is designed and manufactured strictly for competition use only. It is illegal to operate this vehicle on street. Off-road use on public land may be illegal.

Suspension on this vehicle can be adjusted to accomodate differing rider weights and technique, check this manual.

SAFETY WARNINGS:

1. **GASOLINE IS HIGHLY FLAMMABLE:**
 - * Always turn off the engine when refueling.
 - * Take care not to spill on the engine or exhaust pipe/muffler, when refueling.
 - * Never refuel while smoking or in the vicinity of an open flame.
2. If you should swallow some gasoline or inhale a lot of gasoline vapor, or allow some gasoline to get in your eye(s), see your doctor immediately. If any gasoline spills on your skin or clothing, immediately wash it with soap and water, and change your clothes.
3. Always turn off the engine before leaving the machine unattended. When parking the machine, note the following:
 - * The engine and exhaust pipe(s)/muffler(s) may be hot. Park the machine in a place where pedestrians or children are not likely to touch the machine.
 - * Do not park the machine on a slope or soft ground; the machine may overturn.
4. When transporting the motorcycle in another vehicle, be sure it is kept upright and that the fuel cock is turned to the "OFF" position. If it should lean over, gasoline may leak out of the carburetor or fuel tank.
5. Never start your engine or let it run for any length of time in a closed area. The exhaust fumes are poisonous and may cause loss of consciousness and death within a short time. Always operate your machine in an area with adequate ventilation.
6. Always wear a helmet, gloves, boots, trousers, and jacket for moto-cross riding.

CONTENTS

GENERAL INFORMATION	1
DESCRIPTION.....	1
MACHINE IDENTIFICATION.....	1
CONTROL FUNCTIONS.....	2
FUEL AND OIL.....	4
PRE-OPERATION CHECKS.....	5
STARTING AND OPERATION.....	6
PERIODIC MAINTENANCE AND ADJUSTMENT	7
MAINTENANCE AND LUBRICATION SCHEDULE CHART.....	7
SPECIAL TOOLS.....	8
ADJUSTMENTS.....	10
MAINTENANCE AND MINOR REPAIRS	19
ENGINE.....	19
CHASSIS.....	32
WIRING DIAGRAM.....	38
MISCELLANEOUS	40
CABLE ROUTING.....	40
TROUBLESHOOTING.....	42
CLEANING AND STORAGE.....	43
SPECIFICATIONS.....	44
WARRANTY INFORMATION.....	48

GENERAL INFORMATION

DESCRIPTION

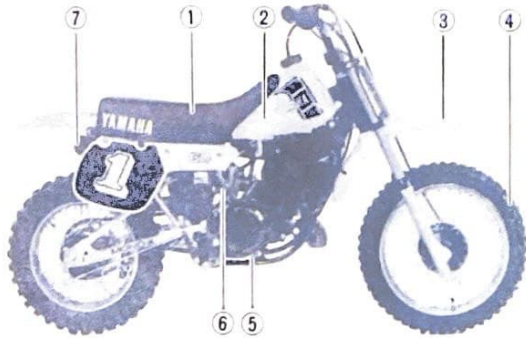

- 1. Seat
- 2. Fuel tank
- 3. Front fender
- 4. Front wheel
- 5. Brake pedal
- 6. Kick starter
- 7. Muffler



- 1. Front fork
- 2. Rear wheel
- 3. Sidestand
- 4. Footrest
- 5. Change pedal

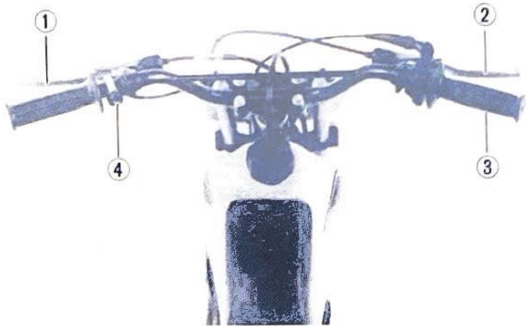

- 1. Clutch lever
- 2. Throttle grip
- 3. Engine stop switch
- 4. Front brake lever

MACHINE IDENTIFICATION

Frame serial number

The frame serial number is stamped on the right side of the steering head pipe.

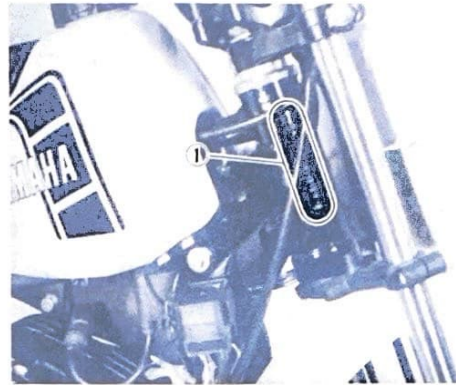

1. Frame serial number

Engine serial number

The engine serial number is stamped on the left side of the engine on top of the crankcase.

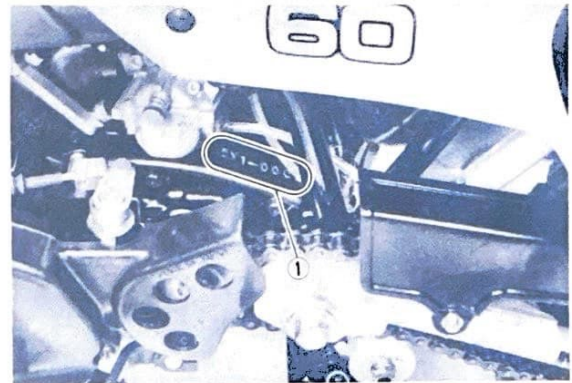

1. Engine serial number

NOTE:

The first digits of these numbers are for model identifications; the remaining digits are the unit production number.

Keep a record of these numbers for reference when ordering parts from your Yamaha dealer.

www.legends-yamaha-online.com

CONTROL FUNCTIONS

WARNING:

Before riding this machine, become thoroughly familiar with all operating controls and their function.

Consult your Yamaha dealer or other qualified mechanic regarding any control or function you do not thoroughly understand.

NOTICE:

This machine is designed strictly for competition use only. It is not equipped with highway approved lighting. Off-road use on public land may be illegal.

Note on handling of the Yamaha Energy Induction System (Y.E.I.S.)

Handle the air chamber, hose with special care. Improper installation or damaged parts will result in poor performance. Replace any cracked or damage parts immediately. No modification of this system in any form is not allowed.

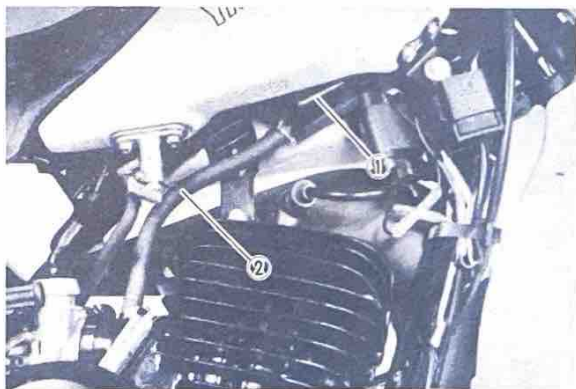

1. Air chamber 2. Hose

Engine stop switch

The engine stop switch is located on the right handlebar.

Push and hold to stop engine.

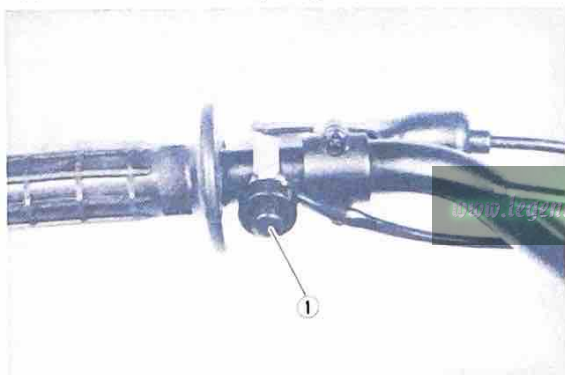

1. Engine stop switch

Fuel cock

The fuel cock functions to supply fuel from the tank to the carburetor and also to filter the fuel.

The fuel cock has the following two positions:

OFF: With the lever in this position fuel will not flow. Return the lever to this position when the engine is not running.

ON: With the lever in this position fuel flows to the carburetor. Normal riding is done with the lever in this position.

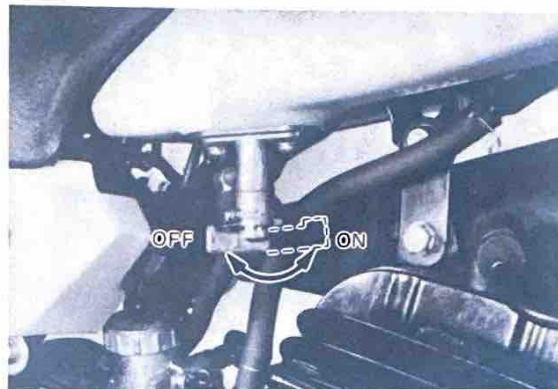

Front brake lever

The front brake lever is located on the right handlebar, pull it toward the handlebar to activate the front brake.

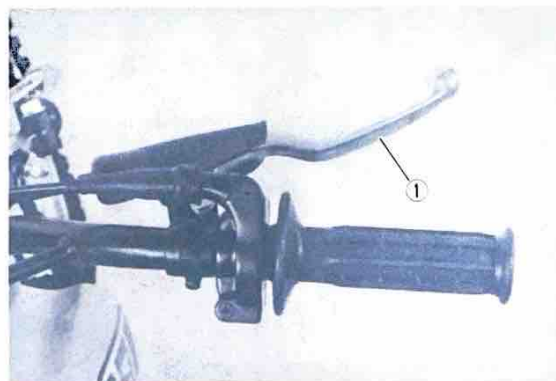

1. Front brake lever

Rear brake pedal

The rear brake pedal is on the right side of the machine. Press down on the brake pedal to activate the rear brake.

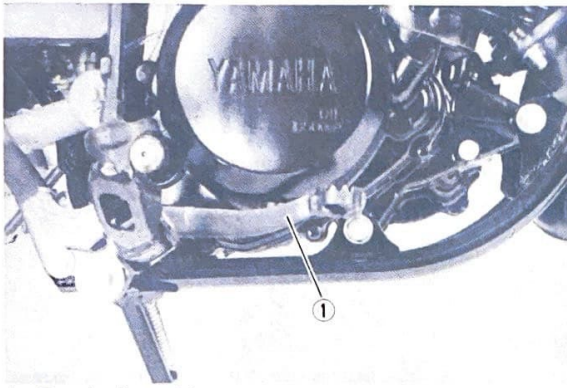

1. Rear brake pedal

Clutch lever

The clutch lever is located on the left handlebar and disengages or engages the clutch. Pull the clutch lever to the handlebar to disengage the clutch and release the lever to engage the clutch. The lever should be pulled rapidly and released slowly for smooth starts.

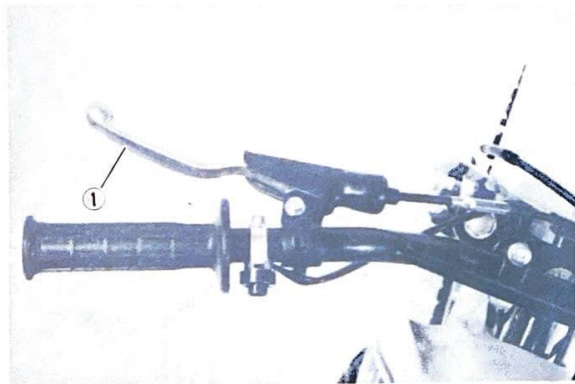

1. Clutch lever

Change pedal

The gear ratios of the constant mesh 6-speed transmission are ideally spaced. The gears can be shifted by using the change pedal on the left side of the engine.

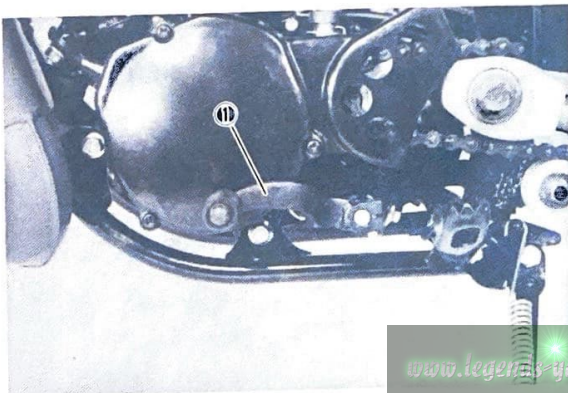

1. Change pedal

Starter knob (choke)

When cold, the engine requires a richer fuel mixture for starting. A separate starter circuit, which is controlled by the starter knob, supplies this mixture.

Pull the knob out to open the circuit (for starting) and push the knob in to close the circuit.

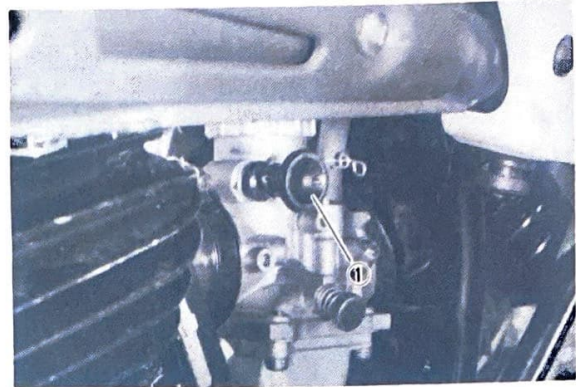

1. Starter knob

Kick starter

To start the engine, rotate the kick starter, push down lightly with foot until gears engage, and then kick with full strength. This model has the primary kick starter so the engine can be started in any gear if the clutch is disengaged. As normal practice, however, shift to neutral before starting.

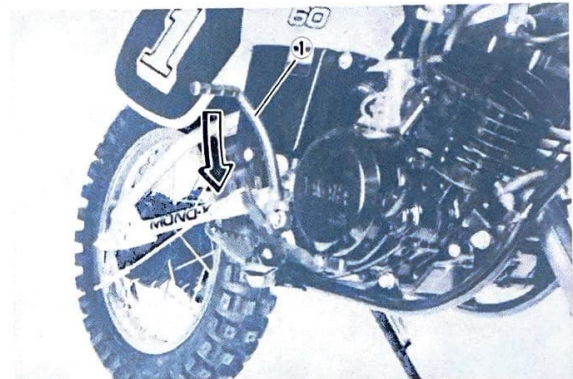

1. Kick starter

Fuel tank cap

Remove the fuel tank breather pipe from fuel tank cap.

Then remove the fuel tank cap by turning counterclockwise.

WARNING:

Do not overfill the fuel tank. Avoid spilling fuel on the hot engine.

Do not fill the fuel tank all the way to the top or it may overflow when the fuel heats up later and expands.

Keep the breather pipe from clogging or fouling.

FUEL AND OIL

Fuel

Use premium gasoline with an octane rating of 90+ mixed with oil at a gas/oil ratio specified below. Always use fresh, name-brand gasoline. Always mix a fresh batch of fuel the morning of the race and do not retain a mixed batch overnight.

Fuel tank capacity: 3.3 lit (0.9 US. gal)

Engine mixing oil

We recommend that your first choice be Yamalube Racing 2-cycle oil.

Mixing ratio: 24 : 1

If for any reason you should use another type, select from the following list.

- * Shell Super M
- * Castrol R 30

Mixing ratio: 20 : 1

Transmission oil

Recommended oil:

Yamalube 4-cycle oil or
SAE 10W/30 "SE" motor oil

Transmission oil capacity:

Periodic oil change:

650 ~ 700 cc (0.69 ~ 0.74 US. qt)

Overhaul:

700 ~ 750 cc (0.74 ~ 0.80 US. qt)

OIL REPLACEMENT

To drain the oil, warm the engine up and remove the drain plug and drain all transmission oil. Reinstall the drain plug (make sure it is secure). Add oil through the filler cap hole.

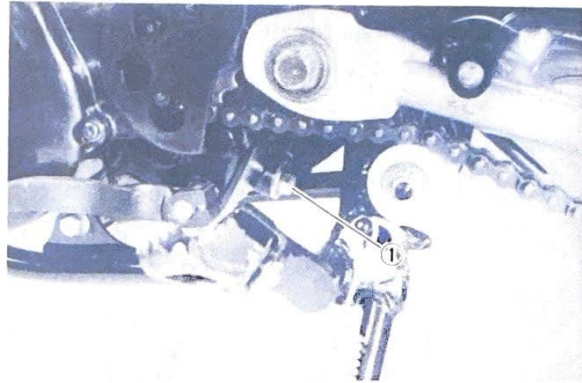

1. Drain plug

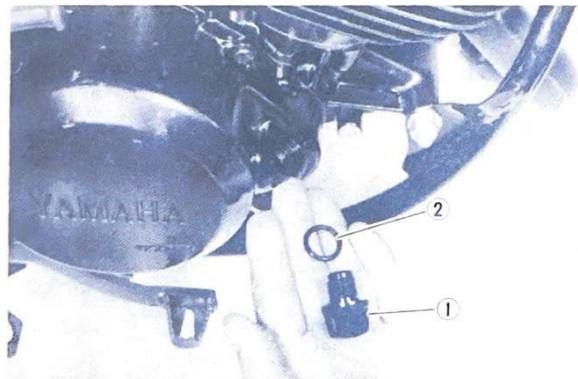

1. Filler cap
2. O-ring

PRE-OPERATION CHECKS

Item	Routine	Page
Brake	Check operation/adjustment	5, 14
Clutch	Check operation/lever adjustment	5, 14
Transmission oil	Change oil as required	4
Drive chain	Check alignment/adjustment/lubrication	14, 15
Spark plug	Check color/condition	10
Throttle	Check for proper throttle cable operation	5, 13
Air filter	Foam type – must be clean and damp w/oil always	12
Wheels and tires	Check pressure/runout/spoke tightness/bead stopper/axle nuts	5, 16, 32 ~ 35
Fittings/fasteners	Check all – tighten as necessary	5, 48

NOTE:

Pre-operation checks should be made each time the machine is used. Such an inspection can be thoroughly accomplished in a very short time; and the added safety it assures is more than worth the time involved.

WARNING:

If any item in the PRE-OPERATION CHECK is not working properly, have it inspected and repaired before operating the machine.

Brake (Front and rear)

Check for correct play in the brake lever and pedal and make sure they are working properly. Check the brakes at low speed shortly after starting out. If the play is correct, make an adjustment.

Clutch

Check for correct play in the clutch lever and make sure the lever operates properly. If the play is incorrect, make an adjustment.

Wheel

Check the wheel runout and damage, and check the tightness of spokes.

Tires

Check the tire pressure and check the tires for wear.

Tire pressure

Front	1.0 kg/cm ² (14 psi)
Rear	1.0 kg/cm ² (14 psi)

Throttle grip

Turn the throttle grip to see that it operates properly and that the play is normal. Make certain the throttle springs are closed when released.

Engine stop switch

Start the engine and make sure the engine stop switch functions properly.

Fittings/Fasteners

Always check the tightness of chassis fittings and fasteners before a ride. Use the chart on page 48 to find the correct torque.

STARTING AND OPERATION

CAUTION:

Prior to operating the machine, perform steps listed in pre-operation check list.

WARNING:

Never start your engine or let it run for any length of time in a closed area. The exhaust fumes are poisonous and can cause loss of consciousness and death within a short time. Always operate your machine in an area with adequate ventilation.

Starting a cold engine

1. Turn the fuel cock to "ON".
2. Operate the carburetor starter (choke) knob and completely close the throttle grip.
3. Shift the transmission into neutral position.
4. Kick the kick starter with full strength to start the engine.
5. After the engine starts, warm up for one or two minutes. Make sure the starter (choke) knob is returned to the original position before riding.

Starting a warm engine

To start a warm engine, refer to the "Starting a cold engine" section. The starter (choke) knob should not be used. The throttle should be opened slightly.

CAUTION:

See "Break-in Section" prior to operating engine for the first time.

Warming up

To get maximum engine life, always "warm-up" the engine before starting off. Never accelerate hard with a cold engine! To see whether or not the engine is warm, see if it responds to throttle normally with the starter (choke) turned off.

WARNING:

Before starting off, be sure to turn up or remove the side stand.

Failure to retract the side stand completely can result in a serious accident when you try to turn a corner.

Engine break-in

1. Prior to starting, fill tank with a break-in gasoline/oil mixture of 12:1 ~ 14:1.
2. Allow engine to warm up. Check engine idling speed. Check operating controls and engine stop switch operation.
3. Operate machine in lower gears at moderate throttle setting for 3 ~ 5 minutes. Check spark plug condition.
4. Allow engine to cool. Repeat procedure, running for 5 minutes. Very briefly, shift to higher gears (4th or 5th) and check full throttle response. Check spark plug condition.
5. Allow engine to cool. Repeat procedure, running for 5 minutes. Full throttle and higher gears may be used, but avoid sustained full throttle operation. Check spark plug condition.
6. Allow engine to cool. Remove top end and inspect. Remove "high" spots on piston with No. 600 grit, wet sandpaper. Clean, and carefully reassemble.
7. Remove break-in fuel/oil mixture from tank. Refill with a mixture specified under "GAS/OIL MIXING RATIO". Check entire unit for loose or mis-adjusted fittings/controls/fasteners.
8. Re-start engine and check through entire operating range thoroughly. Stop. Check spark plug condition. Re-start. After 10 ~ 15 minutes operation, machine is ready to race.

PERIODIC MAINTENANCE AND ADJUSTMENT

MAINTENANCE AND LUBRICATION SCHEDULE CHART

The maintenance and lubrication schedule chart should be considered strictly as a guide to general maintenance and lubrication intervals. You must take into consideration that weather, terrain, geographical locations, and a variety of individual uses all tend to demand that each owner alter this time schedule to match his environment. For example, if the motorcycle is continually operated in an area of high humidity then all parts must be lubricated much more frequently than shown on the chart to avoid rust and damage. If you are in doubt as to how closely you can follow these time recommendations, check with the Yamaha dealer in your area.

Lubrication intervals

Item	Remarks	Type	Initial (hour)				Thereafter every (hour)			
			10	20	40	80	40	80	160	
Transmission oil change	Warm engine before draining	Yamalube 4-cycle oil or SAE 10W/30 type "SE" motor oil		○	○				○	
Drive chain	Lube/Adjust as required Remove/Clean/Lube/Adjust	Yamalube Chain and Cable Lube or SAE 10W/30 motor oil	See service notes							
Control cables	All apply thoroughly	SAE 10W/30 motor oil			○	○			○	
Throttle grip and housing	Apply lightly	Lithium base grease				○			○	
Brake pedal shaft	Apply lightly	Lithium base grease			○				○	
Stand shaft pivot	Apply lightly	Lithium base grease			○				○	
Front forks	Drain completely	Yamaha fork oil 20 wt or SAE 20W motor oil				○			○	
Steering ball race	Inspect thoroughly/Pack moderately	Medium-weight wheel bearing grease				○				○
Point cam lubrication wick	Apply very lightly	Light-weight machine oil			○					○
Wheel bearings	Do not over-pack yearly or ...	Medium-weight wheel bearing grease				○		○	○	

Periodic maintenance intervals

Item	Remarks	Initial (hour)				Thereafter every (hour)		
		10	20	40	80	40	80	160
Brake system (complete)	Check/Adjust as required—repair as required		○	○		○		
Clutch	Check/Adjust as required		○	○		○		
Spark plug	Inspect/Clean or replace as required	○	○	○		○		
Wheels and tires	Pressure/Runout/Spoke—tension	○	○	○		○		
Fittings and fasteners	Tighten before each trip and/or	○	○	○		○		
Drive chain	Tension/Alignment (No. 1)	○	○	○		○		
Air filter	Wet type—clean/Replace as required (No. 2)		○	○	○	○		
Fuel cock	Clean/Flush tank as required	○		○		○		
Ignition timing	Adjust/Clean or replace parts as required		○	○	○		○	
Y.E.I.S.	Inspect air chamber and hose for damage	○	○	○		○		
Carburetor adjustment	Check operation/Timings		○	○	○		○	
Carburetor overhaul	Clean/Repair as required/Refit/Adjust							○
Cylinder compression	Preventive maintenance check		○	○	○		○	
Decarbonize engine	Includes exhaust system			○			○	

SERVICE NOTES:

- No. 1. **DRIVE CHAIN:** In addition to tension and alignment, chain must be lubricated every 0.5 ~ 1.0 hour. If unit is subjected to extremely hard usage and wet weather riding, chain must be checked constantly. See "Lubrication Intervals" for additional details.
- No. 2. **AIR FILTER:** Remove and clean filter every 20 ~ 40 hours.

SPECIAL TOOLS

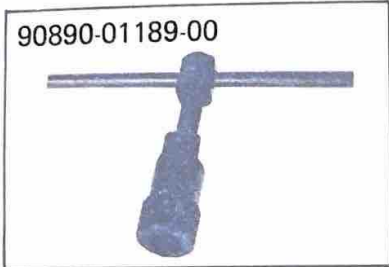

Flywheel holding tool

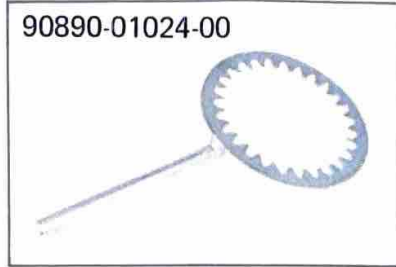

Clutch holding tool



Exhaust ring and steering nut wrench



Dial gauge stand



Dial gauge needle

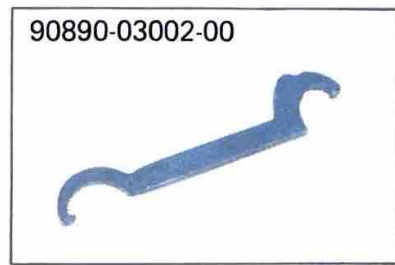

Dial gauge

LUBRICATION

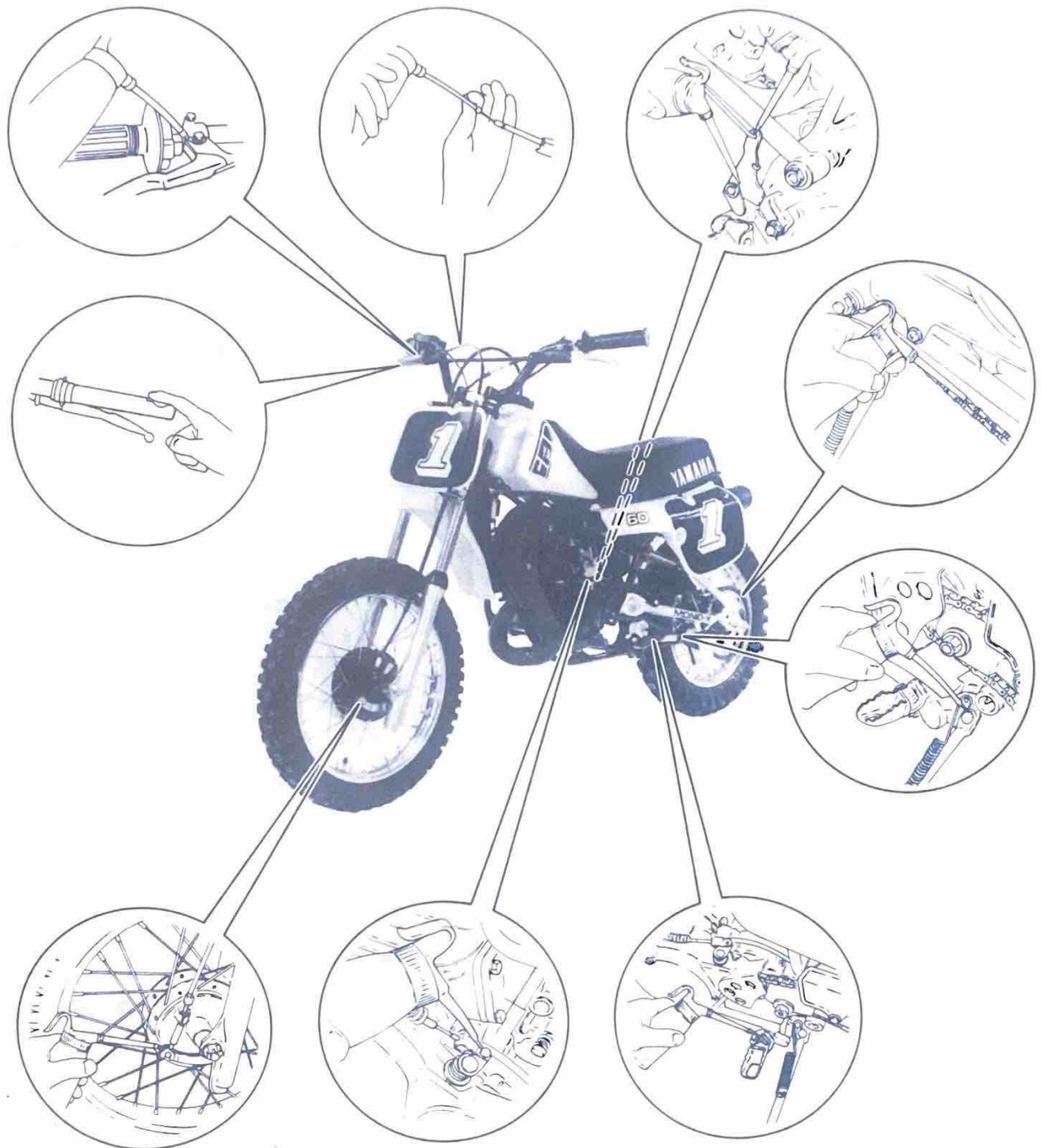

www.legends-yamaha-enduros.com

ADJUSTMENT

WARNING:

The engine, exhaust pipe(s), and muffler(s) will be very hot after the engine has been run. Be careful not to touch them or to allow any clothing item to contact them during inspection or repair.

Spark plug

Standard spark plug:
N-2 (CHAMPION)

1. Measure the electrode gap with a wire thickness gauge.

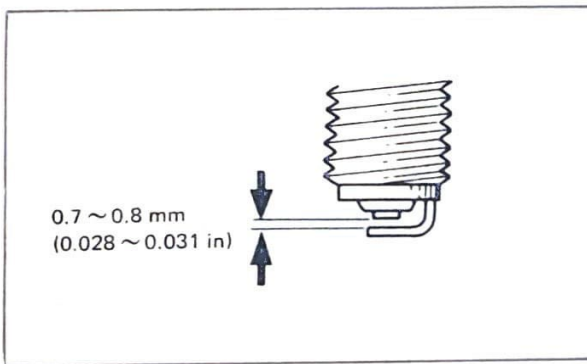

Adjustment can be made by bending the side electrode.

Electrode gap:
0.7 ~ 0.8 mm (0.028 ~ 0.031 in)

When installing the plug, always, clean the gasket surface and use a new gasket. Wipe off any grime from the threads and torque the spark plug properly.

Spark plug torque: 2.5 m·kg (18 ft·lb)

2. The insulator must be a medium-to-light tan color. If not, check carburetion, ignition timing and gas-oil mixing ratio. If the porcelain is a very dark brown or black color, then a plug with a hotter heat range may be required.

This situation is quite common during the engine break-in period. However, use the standard plug. If the insulator tip shows a very light tan or white color or is actually pure white or if the electrodes show signs of melting, then a spark plug with a colder heat range is required.

NOTE:

If a torque wrench is not available when you are installing a spark plug, a good estimate of the correct torque is 1/4 to 1/2 turns past finger tight. Have the spark plug torqued to the correct value as soon as possible with a torque wrench.

IGNITION TIMING

Checking

Ignition timing is checked with a timing light by observing the position of the case mark and rotor mark.

1. Remove the shift pedal and crankcase cover (L).
2. Connect the timing light to the spark plug lead wire.
3. Start the engine and keep it running at the specified speed. Use a tachometer for checking.

Specified speed: 10,000 r/min

4. While keeping the engine running at a specified speed, check that the rotor mark is aligned with the case mark. If they are not aligned, adjust the ignition timing.

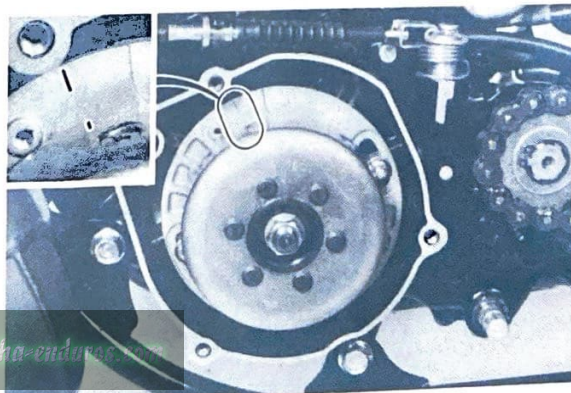

www.legends-yamaha-enduros.com

Adjustment

1. Remove the flywheel magneto.

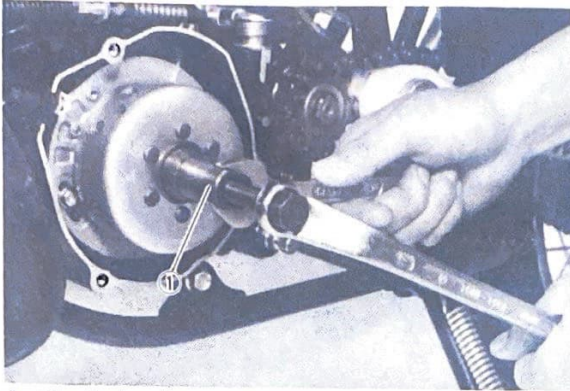

1. Flywheel puller
(90890-01189-00)

2. Loosen the base set screws and turn the base right or left until the base mark aligns the case mark. And tighten the base set screws.

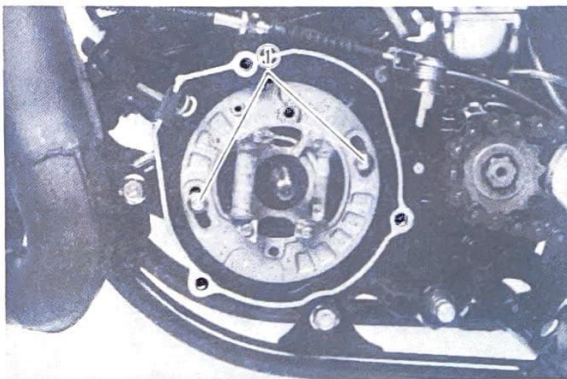

1. Set screw

3. Reinstall the flywheel and tighten the nut.

Tightening torque: 4.0 m·kg (28 ft·lb)

Marking of match mark

If a new crankcase is used, provide a match mark on it and proceed as follows:

1. Remove muffler, spark plug and screw Dial Gauge Stand into spark plug hole.
2. Insert Dial Gauge Assembly with a 56 mm (2.2 in) extension (needle) into stand.
3. Remove left engine crankcase cover.
4. Rotate rotor until piston is at top-dead center (T.D.C.). Tighten set screw on Dial Gauge Stand to secure dial gauge assembly. Set the zero on dial indicator face to line up exactly with dial indicator needle. Rotate flywheel back and

forth to be sure that indicator needle does not go past zero.

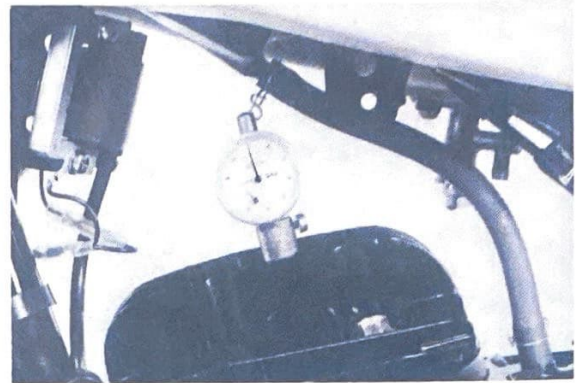

5. Starting at T.D.C., rotate flywheel clockwise until dial gauge reads approximately 3 needle revolutions before-top-dead-center.
6. Slowly turn flywheel counterclockwise until dial gauge reads ignition advance setting listed in specifications table.

Ignition timing:

B.T.D.C. 18° at 10,000 r/min
(1.0 ± 0.15 mm/0.039 ± 0.006 in)

7. Punch a new mark on the crankcase matching the one on the flywheel.

NOTE:

Be sure to locate the piston in the correct position before remarking.

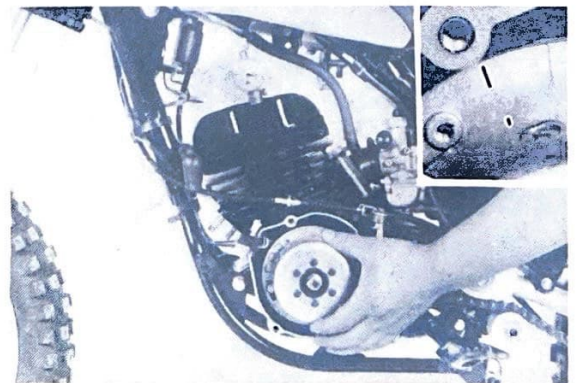

8. Remove dial gauge assembly and stand. Install spark plug and muffler.

Spark plug torque: 2.5 m·kg (18 ft·lb)

9. Install the engine crankcase cover.

AIR FILTER

Removal

1. Remove the side cover and remove the three pan head screws.

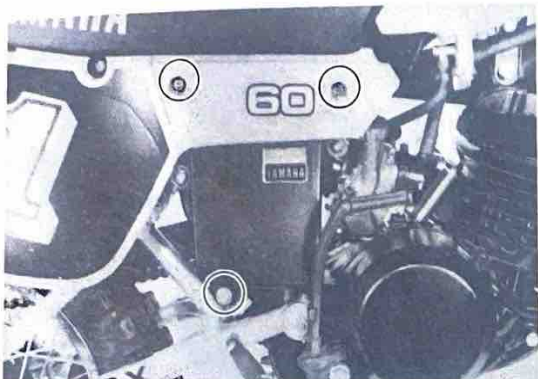

2. Remove the three pan head screws from the element guide.

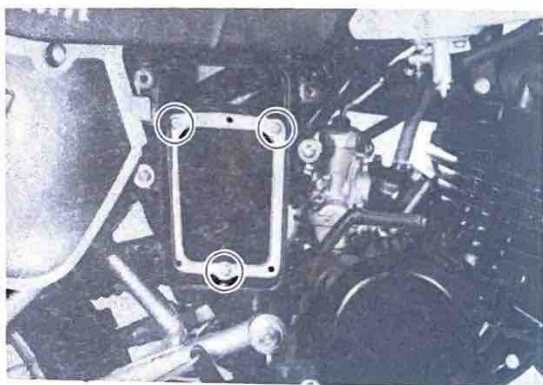

3. Pull out element and guide.

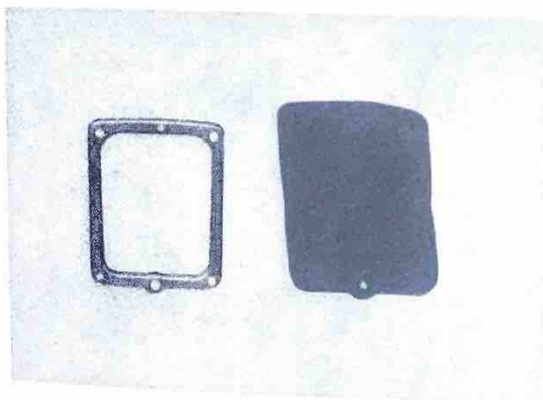

Cleaning

1. Wash the element gently, but thoroughly, in solvent.
2. Squeeze the excess solvent out of the element and let dry.
3. Pour a small quantity of air cooled 2-stroke engine oil onto the filter element and work thoroughly into the porous foam material.

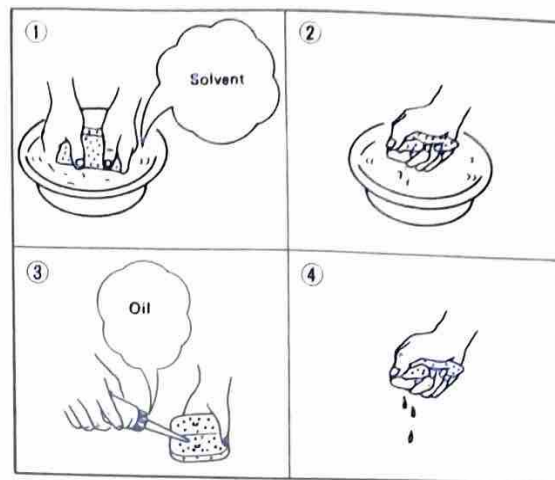

NOTE:

In order to function properly, the element must be damp with oil at all times, but not dripping with oil.

4. Re-insert the filter element guide into the element.
5. Coat the sealing edges of the filter element with light grease. This will provide an air-tight seal between the filter case cover and filter seat.

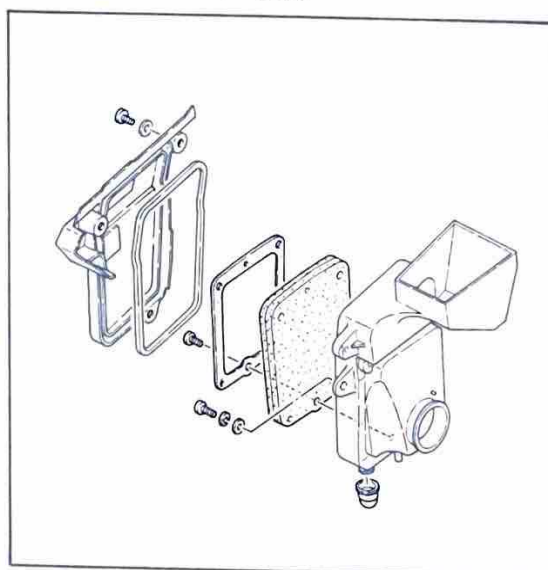

6. Reinstall the element assembly and parts removed for access.

NOTE:

Each time filter element maintenance is performed, check the air inlet to the filter case for obstructions. Check the air cleaner joint rubber to the carburetor and manifold fittings for an air-tight seal. Tighten all fittings thoroughly to avoid the possibility of unfiltered air entering the engine.

CAUTION:

Never operate the engine with the air filter element removed. This will allow unfiltered air to enter, causing rapid wear and possible engine damage. Additionally, operation without the filter element will affect carburetor jetting with subsequent poor performance and possible engine overheating.

Throttle cable adjustment

Check play in turning direction of throttle grip. The play should be 3 ~ 5 mm (0.12 ~ 0.2 in) at grip flange, loosen the lock nut and turn the wire adjuster to make the necessary adjustment. Tighten the adjuster lock nut.

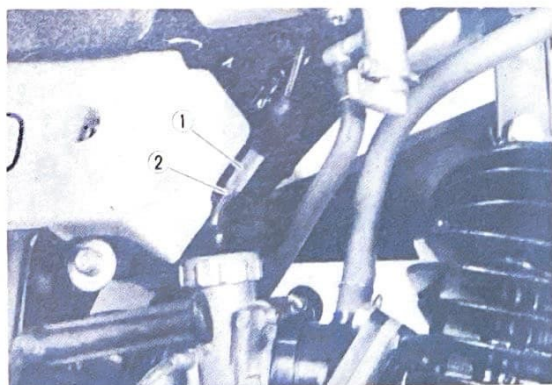
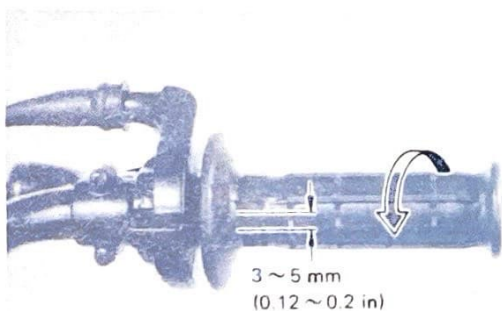

1. Adjuster

2. Lock nut

Idle speed adjustments

1. Turn pilot air screw in until lightly seated.
2. Back out 1 and 1/4 turns. Start the engine and warm it up.

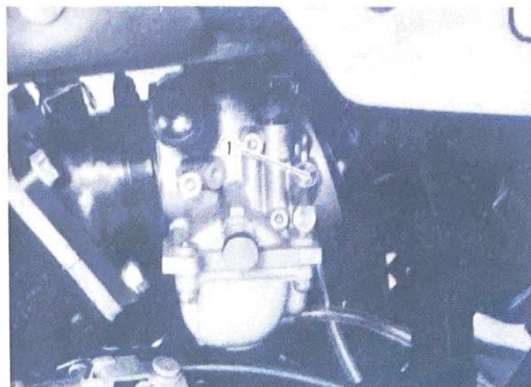

1. Pilot air screw

Pilot air screw: Back out 1 and 1/4 turns.

3. Turn the throttle stop screw until idle is at desired r/min.
4. Turn the pilot air screw in or out until the idle speed is at the highest possible r/min.
5. Turn the throttle stop screw in or out until idle speed is at desired r/min.

Idle speed:

As desired (S.T.D. 1,350 r/min)

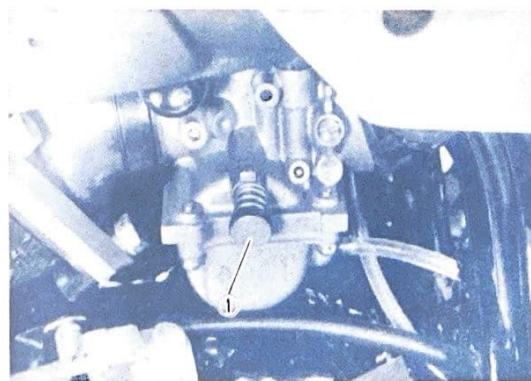

1. Throttle stop screw

If the engine, when warm, hesitates after adjusting as described, turn the idle air mixture screw in or out in 1/4 turn increments until the problem is eliminated.

NOTE:

Pilot air and throttle stop screws should be adjusted so that engine response from idle position is rapid and without hesitation.

Clutch adjustment

The clutch should be adjusted to suit rider preference within a 2 ~ 3 mm (0.08 ~ 0.12 in) free play at the lever pivot side. To adjust, loosen either the handle lever adjuster lock nut or the cable in-line length adjuster lock nut. Next, turn the adjuster either in or out until proper lever free play is achieved.

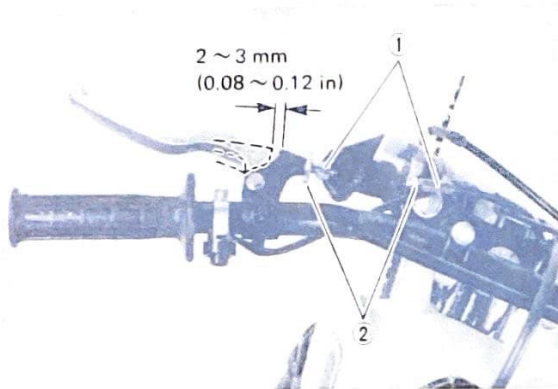

1. Adjuster 2. Lock nut

Front brake adjustment

The front brake should be adjusted to suit rider preference within a 5 ~ 8mm (0.2 ~ 0.3 in) free play at the lever pivot side. Adjustment is accomplished at one of two places; either the handle lever holder or the front brake hub.

1. Loosen the adjuster lock nut.
2. Turn the cable length adjuster in or out until adjustments is suitable.
3. Tighten the adjuster lock nut.

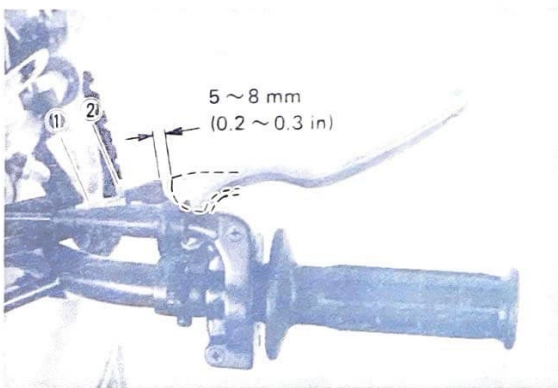

1. Adjuster 2. Lock nut

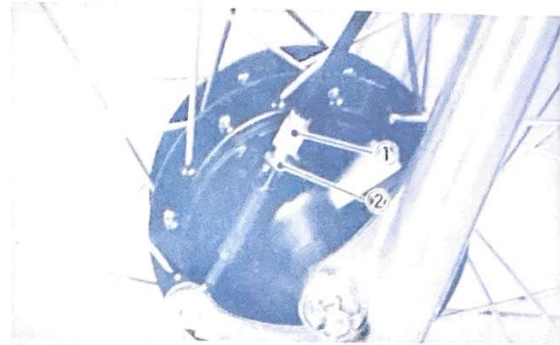

1. Adjuster 2. Lock nut

Rear brake adjustment

The rear brake should be adjusted so the end of the brake pedal moves 20 ~ 30 mm (0.8 ~ 1.2 in). To adjust, turn the adjuster on the brake rod clockwise to reduce play; turn the adjuster counterclockwise to increase play.

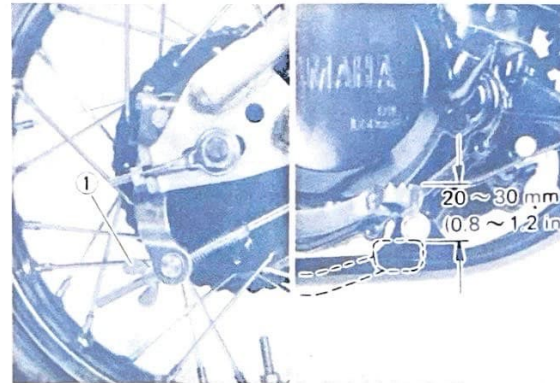

1. Adjuster

Checking the drive chain tension

To check the chain play, the motorcycle must stand vertically with its both wheels on the ground and without passenger on it.

Then measure the play at the bottom of the chain at a point midway between the drive and driven sprockets.

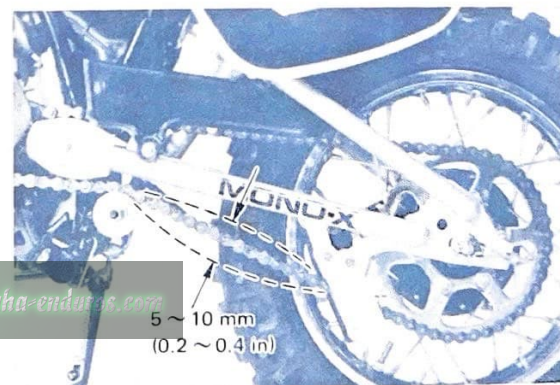

www.legends-yamaha-enduro.com

The normal vertical deflection is approximately 5 ~ 10 mm (0.20 ~ 0.39 in). If the chain deflection is not as specified, adjust the chain tension.

Drive chain tension adjustment

1. Loosen the rear brake rod adjuster.
2. Remove the cotter pin from the rear wheel axle nut with pliers.
3. Loosen the rear wheel axle nut.
4. To tighten chain, turn chain puller adjusting bolt clockwise. To loosen chain, turn adjusting bolts counterclockwise and push wheel forward. Turn each bolt exactly the same amount to main-

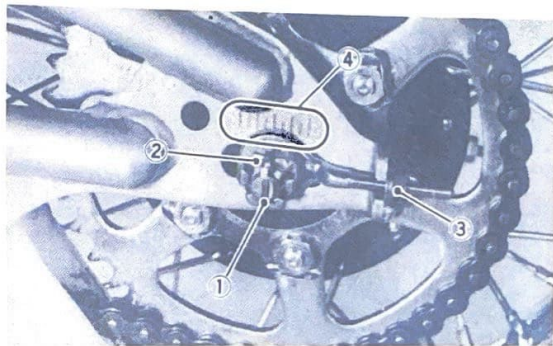

- | | |
|------------------------|------------------------|
| 1. Cotter pin | 3. Adjusting nut |
| 2. Rear wheel axle nut | 4. Marks for alignment |

tain correct axle alignment. (There are marks on each side of rear arm and on each chain puller; use them to check for proper alignment.)

NOTE:

Before adjusting, rotate rear wheel through several revolutions and check tension several times to find the tightest point. Adjust chain tension with rear wheel in this "tight chain" position.

5. After adjusting, be sure to tighten the rear wheel axle nut. (If the nut notch and the cotter pin hole do not match, tighten the nut slightly to match.)

Tightening torque:
4.0 m·kg (29 ft·lb)

6. Also tighten the adjusting nuts against the rear arm (about 1/4 turn each).

7. Insert the cotter pin into the rear wheel axle nut and bend the cotter pin end as shown in the illustration.

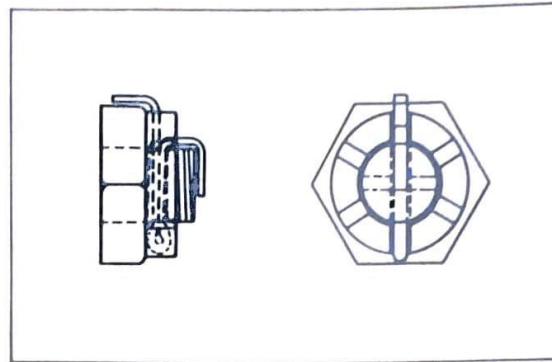

WARNING:

Always use a new cotter pin on the axle nut.

8. In the final step, adjust the play in the brake pedal.

CAUTION:

Excessive chain tension will overload the engine and other vital parts; keep the tension within the specified limits.

Drive chain lubrication

The chain consists of many parts which work against each other. If the chain is not maintained properly, it will wear out rapidly. Form the habit of periodically servicing the chain. This service is especially necessary when driving in dusty conditions.

1. Use any of the many brands of spray type chain lubricant. First, remove dirt and mud from the chain with a brush or cloth and then spray the lubricant between both rows of side plates and on all center rollers.
2. To clean the entire chain, first remove the chain from the machine, dip it in solvent and clean out as much dirt as possible. Then take the chain out of the solvent and dry it. After drying, lubricate the chain to prevent the formation

of rust.

www.legends-yamaha-enduros.com

Tire air pressure

Improper tire pressure affects the smoothness of the tire, traction, handling and the life of the tires. Always maintain the correct tire pressure.

Tire pressure:

Front	1.0 kg/cm ² (14 psi)
Rear	1.0 kg/cm ² (14 psi)

Check the spokes

If they are loose or bent, tighten or replace them. The spokes should be checked before each use.

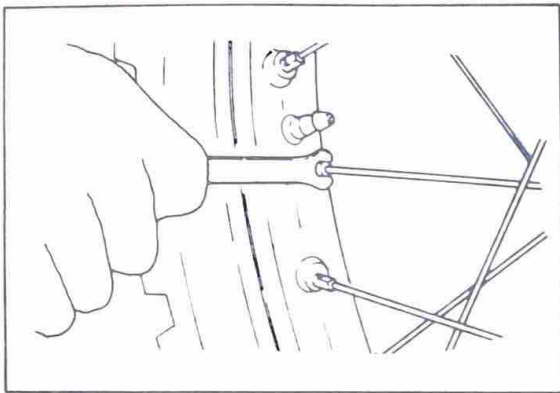

Steering inspection

Periodically inspect the condition of the steering. Worn out or loose steering bearings may be dangerous.

Place a block under the engine to hold the front wheel of the machine off the ground; then hold the lower end of the front fork and try to move forward and backward.

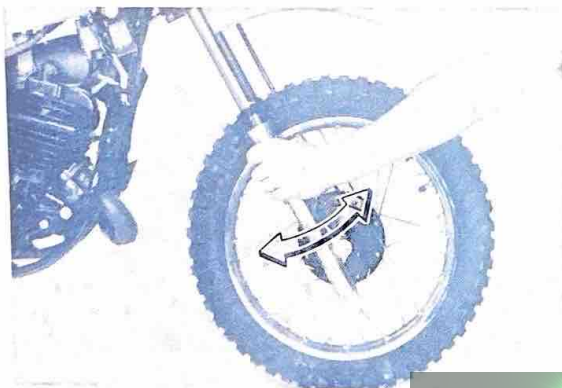

www.legends-yamaha-enduros.com

Steering adjustment

1. To adjust, loosen stem bolt.
2. Use ring nut wrench to tighten ring nut.

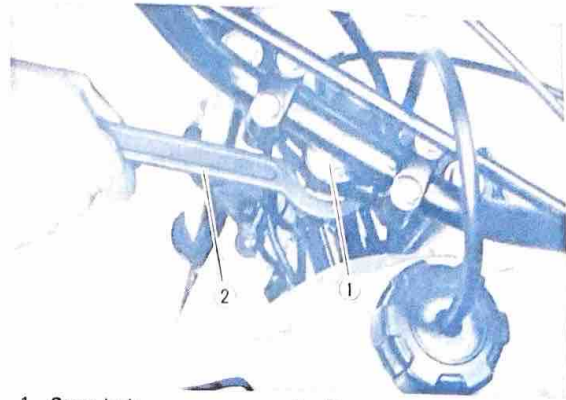

1. Stem bolt

2. Ring nut wrench

CAUTION:

Forks must swing from lock to lock without binding or catching.

3. Tighten stem bolt.

Tightening torque: 6.0 m·kg (43 ft·lb)

NOTE:

Steering head disassembly must be performed by your Yamaha dealer or other qualified mechanic.

Front fork oil change

WARNING:

1. Fork oil leakage can cause loss of stability and safe handling. Have any problem corrected before operating the machine.
2. Securely support the machine so there is no danger of it falling over.

1. Remove cap bolts from inner fork tubes.
2. With the front wheel and front brake cable removed, the fork legs can be removed from the upper and lower brackets by loosening upper and lower pinch bolts.

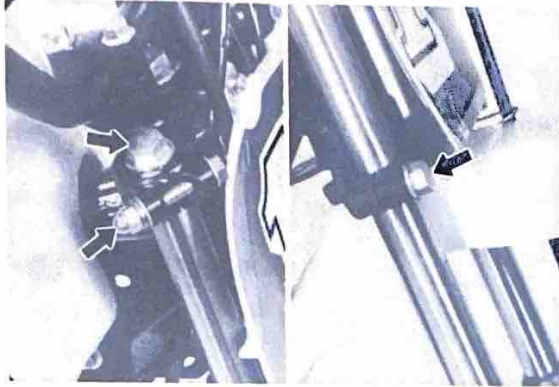

3. Drain the oil from fork.
4. Installing the front forks on the frame. Bring up the front forks to the correct position and partially tighten the under-bracket mounting bolt. Pour specified amount of oil into the inner tube through the upper end opening.

Recommended oil:
 Yamaha fork oil 20 wt or
 SAE 20W motor oil
 Capacity per leg: 79.1 cc (2.7 US oz)

NOTE:
 Select the weight oil that suits local conditions and your preference (lighter for less damping; heavier for more damping).

5. After filling, slowly pump the outer tubes up and down to distribute the oil.

NOTE:
 Adjust the oil levels in both right and left front forks so they are even.

6. Inspect O-ring on fork cap bolts and replace if damaged. Install the fork cap bolts and torque to specification.

Fork cap bolt torque:
 2.0 m·kg (14.5 ft·lb)



1. O-ring

Rear shock absorber (monocross suspension "De Carbon" system)

WARNING:

This shock absorber contains highly compressed nitrogen gas.

Read and understand the following information before handling the shock absorber. The manufacturer cannot be held responsible for property damage or personal injury that may result from improper handling.

1. Do not tamper with or attempt to open the cylinder assembly. Injury may result.
2. Do not subject shock absorber to an open flame or other high heat. This may cause the unit to explode due to excessive gas pressure.
3. Do not deform or damage the cylinder in any way. Cylinder damage will result in poor damping performance.
4. Handle it with great care, for a score or scratch in the piston rod sliding portion will cause oil leakage.

Notes on disposal (Yamaha dealers only)

Gas pressure must be released before disposal of shock absorber. To do so, drill a 2 ~ 3 mm (0.08 ~ 0.12 in) hole through the cylinder wall at a point 10 ~ 15 mm (0.4 ~ 0.6 in) above the bottom of the cylinder.

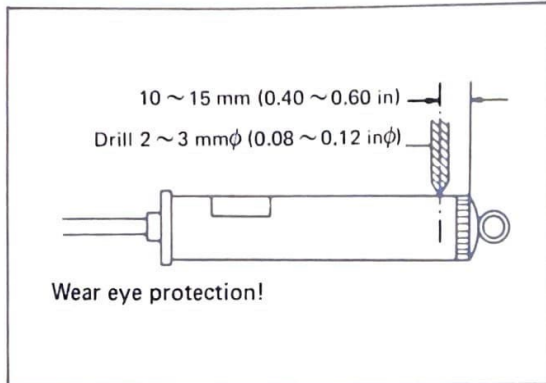

CAUTION:

Wear eye protection to prevent eye damage from escaping gas and/or metal chips.

WARNING:

To dispose of a damage or wornout shock absorber, take the unit to your Yamaha dealer or other qualified mechanic for this disposal procedure.

Adjustment

Using a screwdriver, make an adjustment of rear shock absorbers.

- When bottoming feels excessive and too soft:
 1. Increase the spring pre-load.
- When springing feels excessive and too hard:
 1. Decrease the spring pre-load.

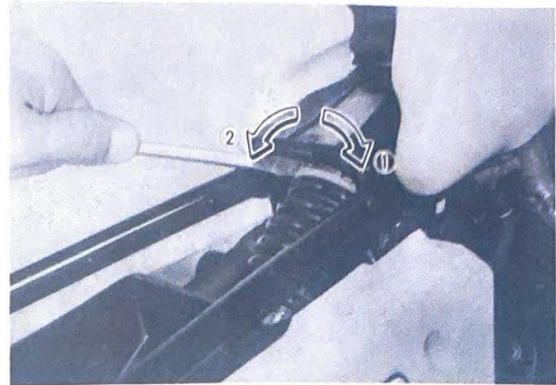

1. Soft 2. Hard

Spring pre-load	STD	Hard			
		1	2	3	4
Position	●				

Suspension settings

1. The front forks and rear shock absorber are designed, assuming that the rider's weight including his riding equipment is 50 kg (110 lb).
2. For suspension bottoming during a ride, the following types are available as option for front and rear use. Please use the type that best suits your riding.

Front fork spring			
STD Type	5X1-23141-00	k = 0.2 kg/mm	—
Hard Duty Type	5X1-23141-10	k = 0.225 kg/mm	
Rear shock spring			
STD Type	5X1-22212-00	k1 = 2.5 kg/mm	—
Hard Duty Type	5X1-22212-10	k = 3.1 kg/mm	Blue painting

MAINTENANCE AND MINOR REPAIRS

PREPARATION FOR SERVICE

1. Before servicing the machine, be sure to clean machine exteriors.
2. Place the removed parts, always on a tray in the order of removal.
3. When replacing parts, always use genuine Yamaha parts to maintain better performance, durability and safety.
4. All gaskets and seals should be replaced when an engine is overhauled. All gasket surfaces must be cleaned.
5. Properly oil all mating engine and transmission parts during assembly.
6. All circlips should be inspected before assembly. Replace distorted circlips.
7. Always replace cotter pins and piston pin clips after one use.
8. When installing parts, apply grease or oil to them, as required, and following the torque chart. (Refer to "Maintenance and Lubrication Schedule Chart".)
9. For assembly, reverse the procedure for removal.

ENGINE

CARBURETOR

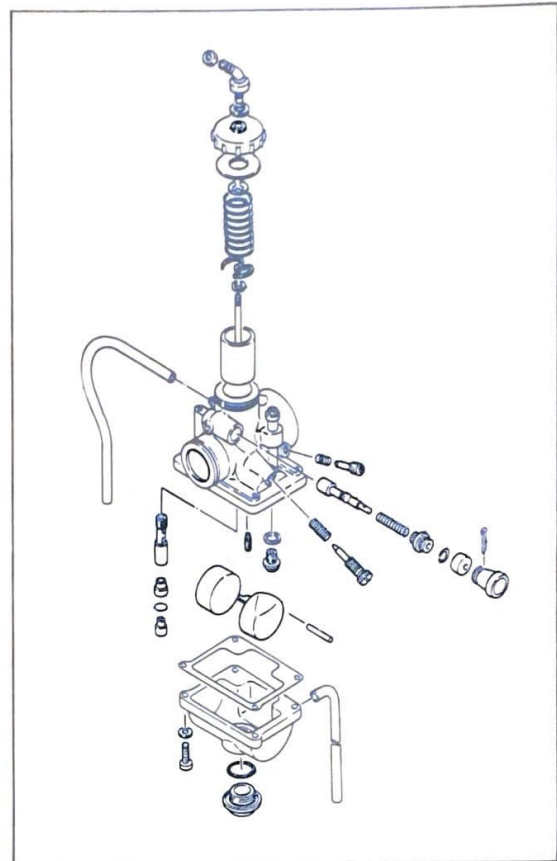

Replacement of main jet

1. Turn fuel cock lever to the "OFF"
2. Disconnect the fuel hose.
3. Loosen the manifold and inlet joint bands (hose clamps).

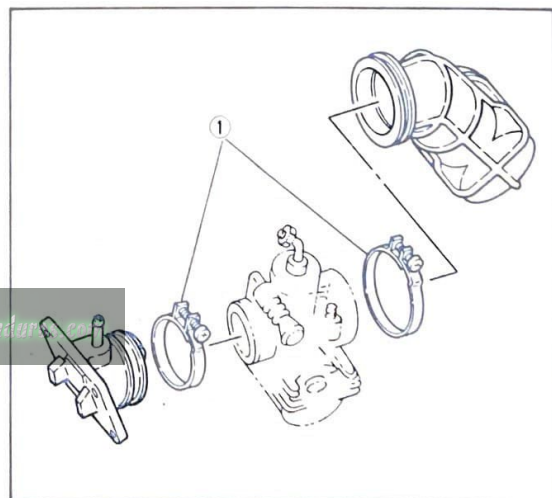

1. Joint band

4. Rotate carburetor, exposing main jet cover bolt.
5. Remove bolt. Main jet is located directly behind bolt.

WARNING:

Removing the main jet cover bolt will allow the fuel in the float bowl to drain. Do not remove if engine is hot. Place a rag under carburetor to catch overflow.

Remove bolt in well-ventilated area. Do not remove near open flame. Always clean and dry the machine after reassembly.

6. Change as required. Reinstall cover bolt and reassemble, reversing steps "1" through "4".

Standard main jet: #200

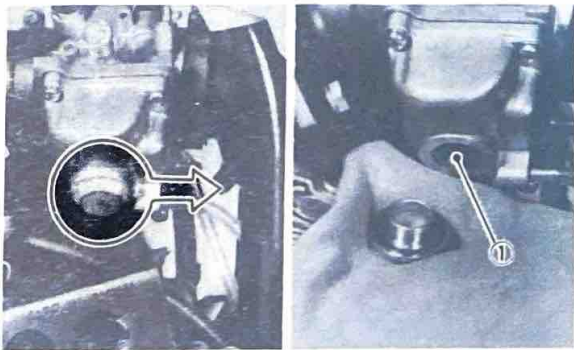

1. Main jet

IMPORTANT:

The YZ60J Carburetor has been set for normal sea level conditions. The standard setting is the result of extensive testing and does not usually require changing. However, under conditions of high atmospheric pressure or heavy load (deep sand or mud) the standard main jet should be replaced with another main jet. If the carburetor requires any other setting changes to suit local conditions of altitude, weather, etc., the change must be made with great care. Improper carburetor setting changes will cause poor engine performance and possible engine damage.

Please consult your Yamaha dealer or other qualified mechanic about any carburetor setting changes before actually going about them.

Inspection

1. Examine carburetor body and fuel passages. If contaminated, wash carburetor in petroleum based solvent. Do not use caustic carburetor cleaning solutions. Blow out all passages and jets with compressed air.
2. Examine condition of floats. If floats are leaking or damaged, they should be replaced.
3. Inspect inlet needle valve and seat for wear or contamination. Replace these components as a set.

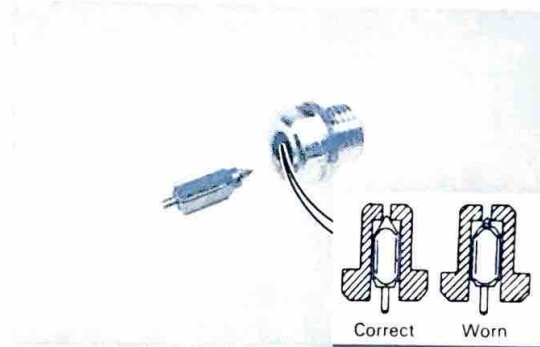

Adjustment

1. Float height
 - a. Checking

Hold the carburetor in an upside down position. Incline the carburetor at 60° ~ 70° (so that the end of the float valve does not hang down of float weight), and measure the distance from the mating surface of the float chamber (gasket removed) and carburetor to the top of the float arm using a gauge.

Float height:

21.0 ± 1 mm (0.83 ± 0.039 in)
Level with carburetor base

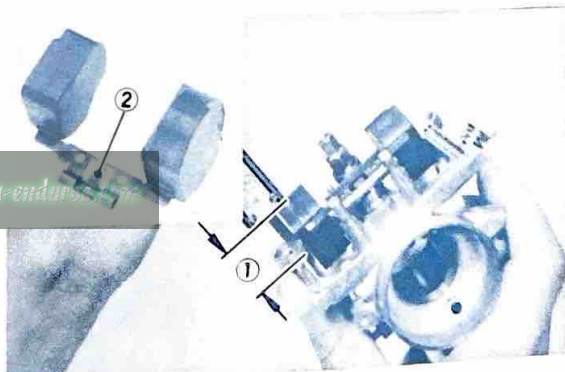

1. Float height 2. Tang

b. Adjustment

CAUTION:

Check the needle valve and valve seat for wear before adjustment.

Make the adjustment by bending the tang on the float arm.

2. Jet needle

The mid-range air/fuel supply is affected by the position of the needle in the needle jet. If it is necessary to alter the mid-range air/fuel mixture characteristics of the machine, the jet needle position may be changed. Move the jet needle up for a leaner condition or toward the bottom position for a richer condition.

Jet needle type: 4K4
Clip position: No. 3 Groove

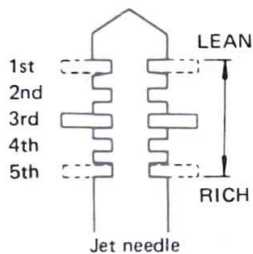

REED VALVE

Removal

1. With carburetor, top end, and muffler removed, remove the four (4) bolts holding the intake manifold and reed valve assembly to the cylinder. Remove the assembly.

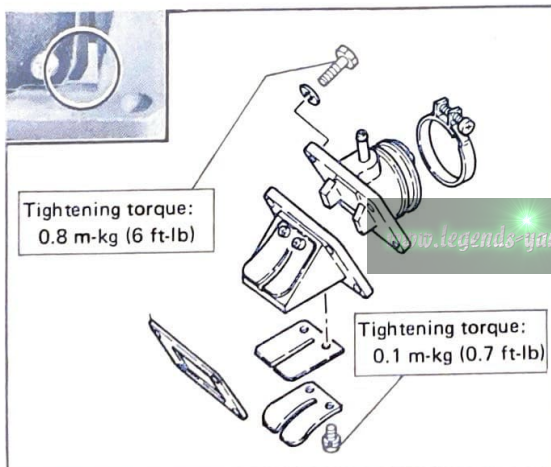

Inspection

1. Inspect rubber intake manifold for signs of weathering, checking or other deterioration.
2. Inspect reed petals for signs of fatigue and cracks. Reed petals should fit flush or nearly flush against neoprene seats. If in doubt as to sealing ability, apply suction to carburetor side of assembly. Leakage should be slight to moderate.
3. The valve stopper controls the movement of the valve. Check clearance "a".

Standard valve "a": 9 mm (0.35 in)

If it is 0.5 mm (0.02 in) more or less than specified, replace the valve stopper.



4. Check reed valve for bending. If beyond tolerance, replace reed valve.

Reed valve bending limit:
0.3 mm (0.012 in) or less

Yamaha Energy Induction System (Y.E.I.S.)

CAUTION:

Never attempt to modify the Yamaha Energy Induction System.

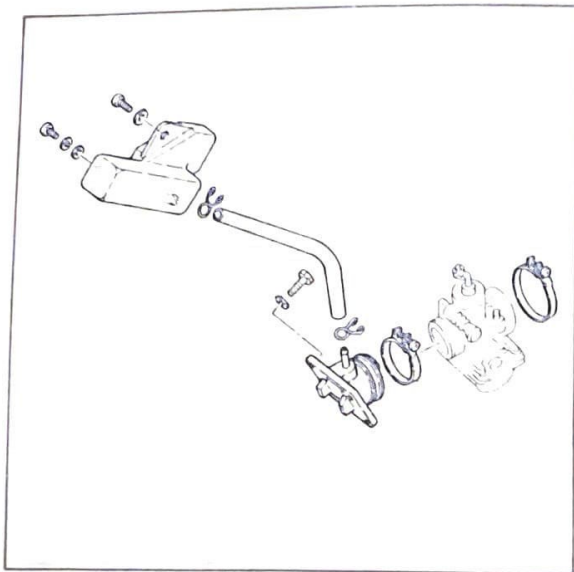

Inspection

1. Check the hose for damage, and replace it, as required.



2. Check the air chamber for damage, and replace it as required.

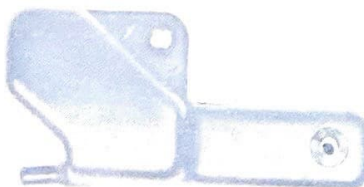

3. Check that the hose is clipped correctly, and if not, refit clips.

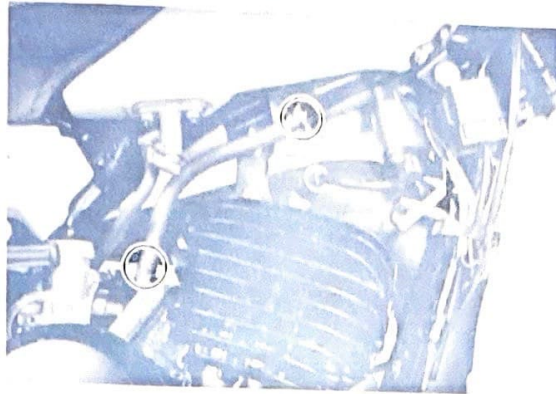

MUFFLER

With the carburetor removed, proceed as follows:

Removal

1. Remove the side cover (L.H.).
2. Remove the nuts holding muffler to cylinder and remove the muffler mounting bolts, and screw.

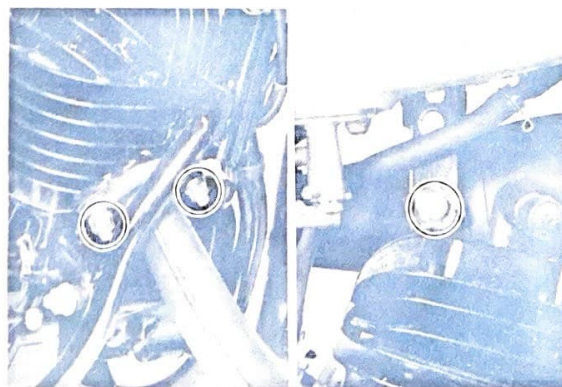

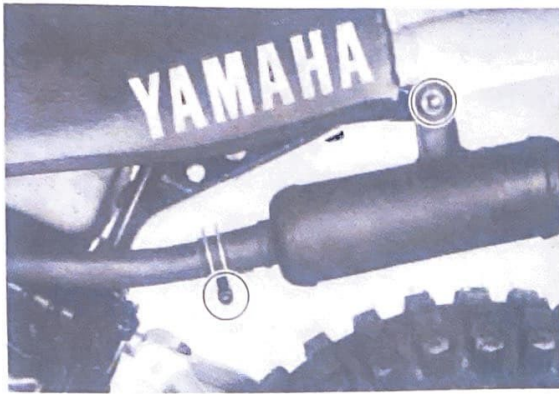

Maintenance

1. Using a rounded scraper, remove excess carbon deposits from manifold area of exhaust pipe. Check muffler gasket condition. The gasket seat is located around the cylinder exhaust port.



2. Carbon deposits within the silencer may be removed by lightly tapping the outer shell with a hammer and then blowing out with compressed air. Heavy wire, such as a coat hanger, may be inserted to break loose deposits. Use care.

TOP END

Removal

1. Remove the side covers.
2. Remove the two bolts and remove seat.
3. Turn the fuel cock to "OFF" position and disconnect the fuel pipe. Remove the securing bolt and holding band from fuel tank. Lift rear of the fuel tank up and pull back to clear frame mounts. Remove tank.

www.legends-yamaha-enduro.com

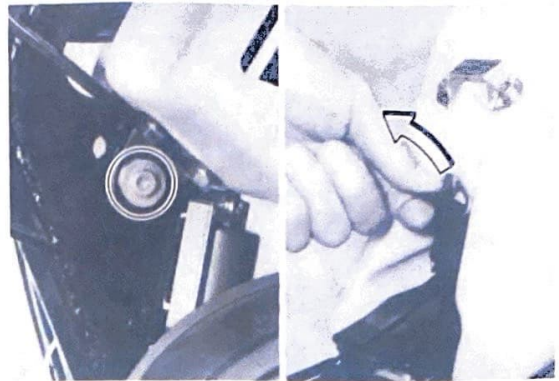

4. Remove spark plug lead wire. Loosen, but do not remove spark plug.
5. Remove nuts securing cylinder and head (4 nuts).
Remove cylinder head and gasket.

NOTE:

Break each nut loose (1/4 turn) prior to removing.

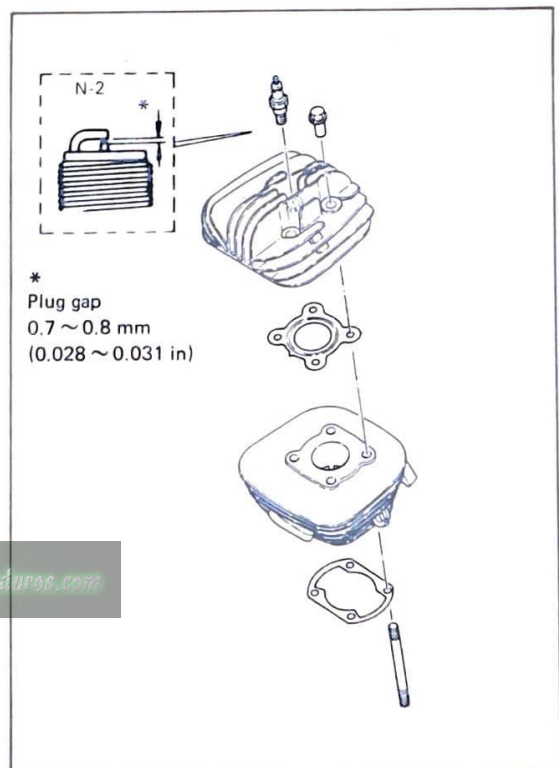
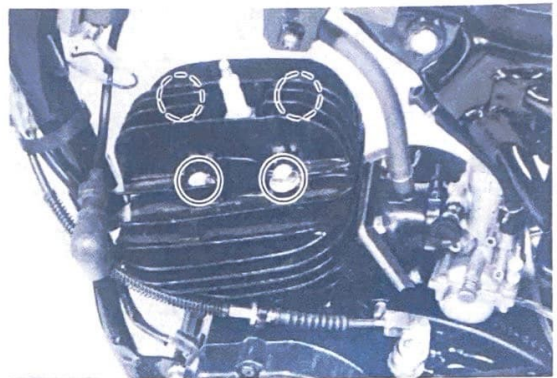

- Remove the clutch wire.

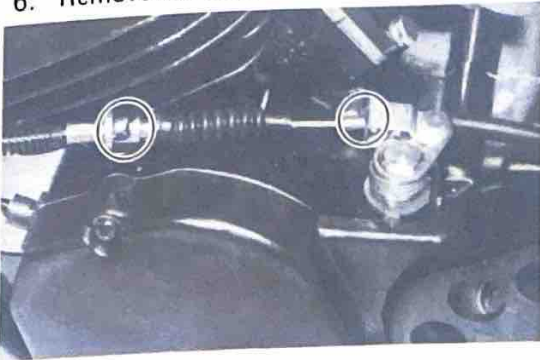

- With the piston at top dead center, rise the cylinder until the cylinder skirts clear crankcase. Stuff a clean shop rag into crankcase cavity, around rod, to prevent dirt and other foreign particles from entering. Remove cylinder.
- Remove the piston pin clip from the piston. Push the piston pin out from opposite side. Remove the piston.

NOTE:

If the pin hangs up, use a piston pin puller. Do not hammer on pin as damage to rod, piston and bearing will result.

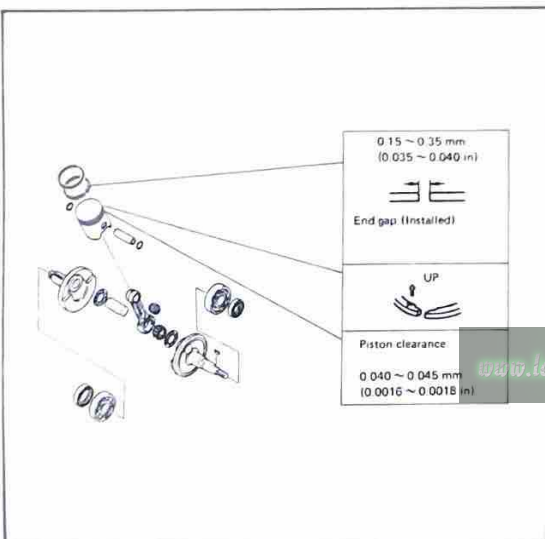
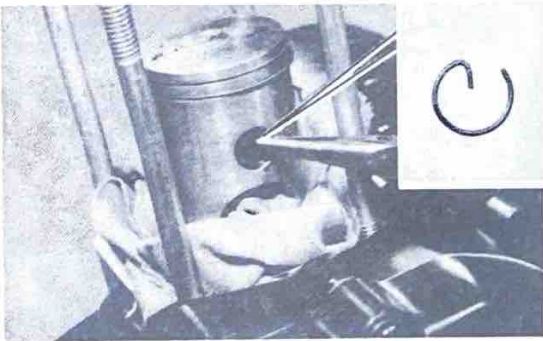

Maintenance

Cylinder head

- Remove spark plug.
- Using a rounded scraper, remove carbon deposits from combustion chamber. Take care to avoid damaging the spark plug threads. Do not use a sharp instrument. Avoid scratching the metal surface.



- Place the head on a surface plate. There should be no warpage. Correct by resurfacing. Place 400 ~ 600 grit wet emery sandpaper on surface plate and re-surface head using a figure-eight sanding pattern. Rotate head several times to avoid removing too much material from one side.
- Clean the spark plug gasket mating surface thoroughly.

Cylinder

- Remove reed valve assembly.
- Using a rounded scraper, remove carbon deposits from exhaust port.



- Check cylinder bore. Using a cylinder hone, remove any scoring. Hone lightly, using smooth stones. Hone no more than required to avoid excess piston clearance.

Piston

1. Using a rounded scraper, remove carbon deposits from piston crown.
2. Break a used piston ring in two. File end square. De-burr edges to avoid scratching ring groove and clean carbon deposits from ring grooves.

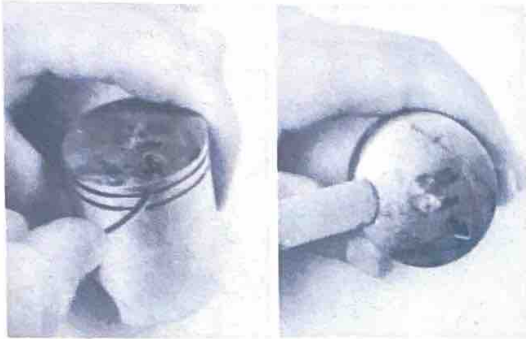

3. Using 400 ~ 600 grit wet sandpaper, lightly sand score marks and lacquer deposits from sides of piston. Sand in cross-hatch pattern. Do not sand excessively.



Piston clearance

1. Cylinder bore measurement

Using a cylinder gauge set to standard bore size, measure the cylinder. Measure front-to-rear and side-to-side at top, center and bottom just above exhaust port. Compare minimum and maximum measurements. If over tolerance and not correctable by honing, rebore to next oversize.

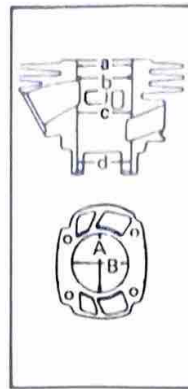

2. Piston outside diameter measurement
Using an outside micrometer, measure piston diameter. The measuring point is at right-angles to the piston pin holes, about 20 mm (0.8 in) from the bottom of the piston skirts.
3. Make a correct calculation of the piston clearance using the following formula.

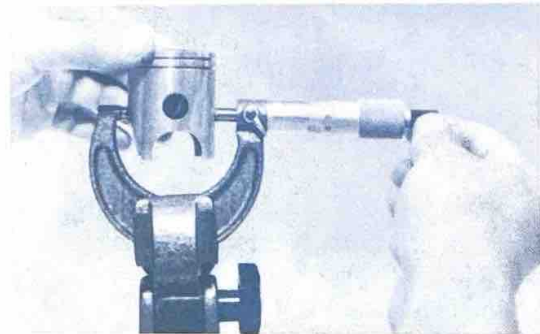

- ACTUAL PISTON DIAMETER
= Measurement + 0.040 mm (0.0016 in)
- PISTON CLEARANCE
= Minimum Cylinder Diameter
– Maximum Piston Diameter

EXAMPLE:

- ACTUAL PISTON DIAMETER
= 41.915 mm + 0.040 mm = 41.955 mm
(1.6502 in + 0.0016 in = 1.6518 in)
- PISTON CLEARANCE
= 42.000 mm – 41.955 mm = 0.045 mm
(1.6535 in – 1.6518 in = 0.0018 in)

Normal piston clearance

0.040 ~ 0.045 mm
(0.0016 ~ 0.0018 in)

If beyond tolerance replace piston or rebore cylinder as required.

Piston rings

1. Remove ring from piston.
2. Insert ring into cylinder. Push down approximately 20 mm (0.79 in) using piston crown to maintain right-angle to bore. Measure installed end gap. If beyond tolerance, replace.

Ring end gap installed (top and 2nd):
0.15 ~ 0.35 mm (0.035 ~ 0.040 in)

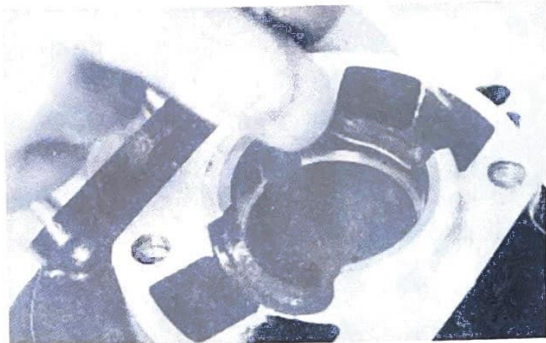

3. With rings installed in grooves, insert feeler gauge between ring and groove. If beyond tolerance, replace ring and/or piston as required.

Ring groove clearance:
0.02 mm (0.0008 in)

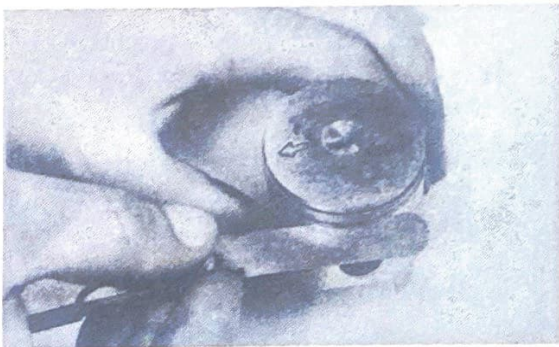

4. Holding cylinder towards light, check for full seating of ring around bore. If not fully seated, check cylinder. If cylinder is not out-of-round, replace piston ring.
5. During installation, make sure ring ends are properly fitted around ring locating pin in piston groove. Apply liberal coating of two-stroke oil to ring.



NOTE:

New rings require break-in. Follow first portion of new machine break-in procedure.

Piston pin bearing and connecting rod

1. Check the pin for signs of wear. If any wear is evident, replace pin and bearing.
2. Check the pin and bearing for signs of heat discoloration. If excessive (heavily blued), replace both.
3. Check the bearing cage for excessive wear. Check the rollers for signs of flat spots. If found, replace pin and bearing.
4. Apply a light film of oil to pin and bearing surfaces. Install in connecting rod small end. Check for play. There should be no noticeable vertical play. If play exists, check connecting rod small end diameter for wear. Replace pin and bearing or all as required.
5. Mount the dial gauge at right angles to connecting rod small end holding the bottom of rod toward the dial indicator, rock top of rod and measure axial play.

Connecting rod axial play:
0.5 ~ 1.2 mm (0.020 ~ 0.047 in)

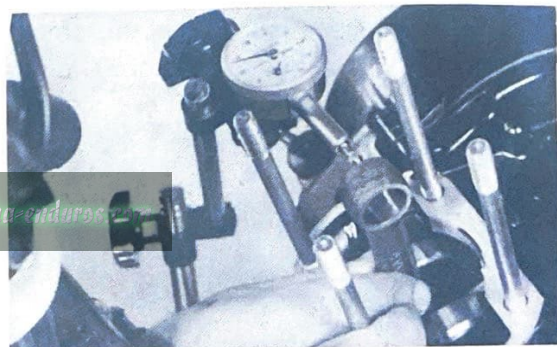

- Remove the dial gauge and slide the connecting rod to one side. Insert a feeler gauge between the side of the connecting rod big end and the crank wheel. Measure clearance.

Connecting rod/crank side clearance:
0.2 ~ 0.7 mm (0.008 ~ 0.028 in)

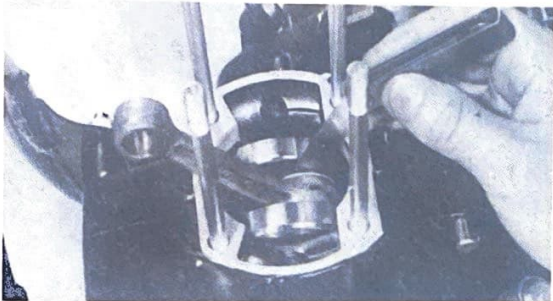

- If any of the above measurements exceed tolerance, crankshaft repair is required. Take the machine to your authorized dealer.
- During reassembly apply a liberal coating of two-stroke oil to the piston pin and bearing. Apply several drops of oil to the connecting rod big end. Apply several drops of oil into each crankshaft bearings oil delivery hole.

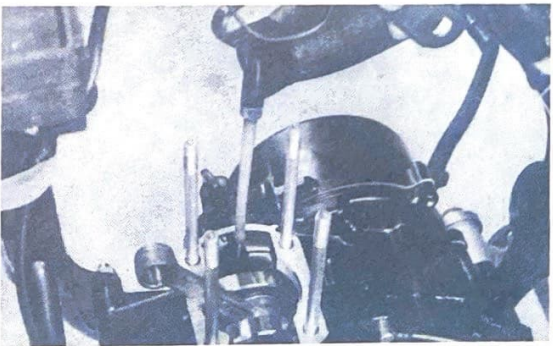

CLUTCH

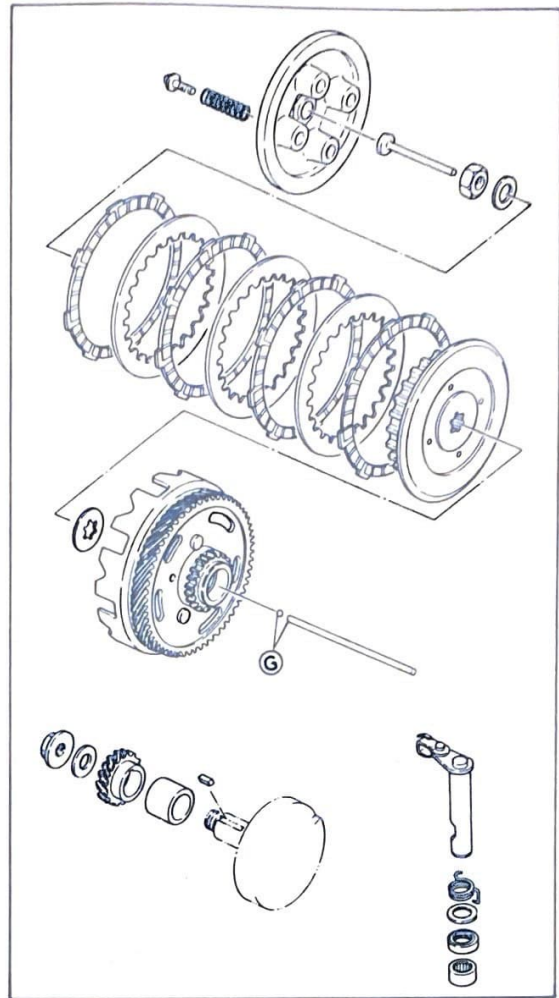

Removal

- Remove the rear brake adjuster.
- Remove the kick starter.
- Remove the footrest.

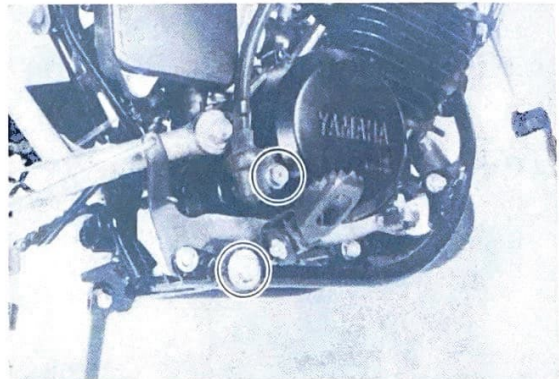

- Remove the pan head screws holding the case cover in place and remove the cover. Note the position of the dowel pins.

NOTE:
Drain transmission oil before removing cover.

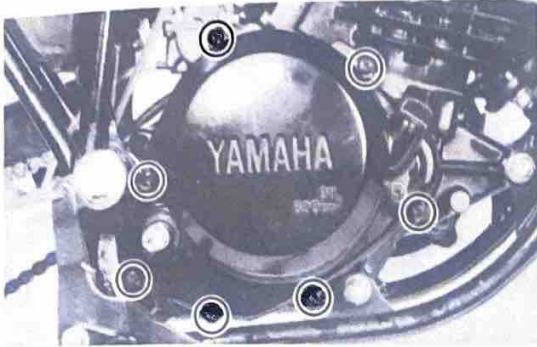

- Remove the Phillips screw (4) holding the pressure plate. Remove the clutch springs (4), pressure plate and push rod. Remove the clutch plates and friction plates.

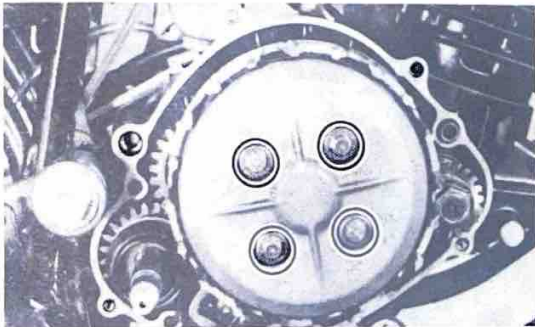

NOTE:
When removing Phillips (hexagon) spring screws, loosen each screw in several stages working in a cross-hatch pattern to avoid any unnecessary warpage. Note the condition of each piece as it is removed and its location with the assembly.

- Using the clutch holding tool, remove the clutch securing nut and lock washer. Remove the clutch boss and driven gear (clutch housing).

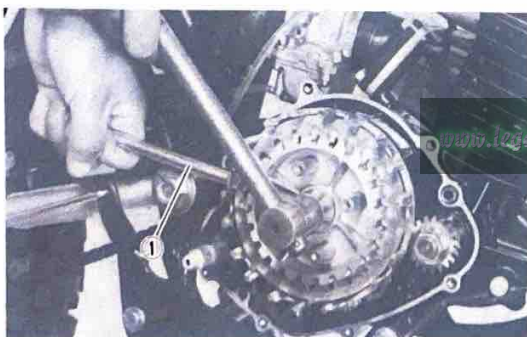

1. Clutch holding tool

Inspection

- Measure each clutch spring. If beyond tolerance, replace.

	New	Minimum
Clutch spring free length	30.1 mm (1.19 in)	29.1 mm (1.15 in)

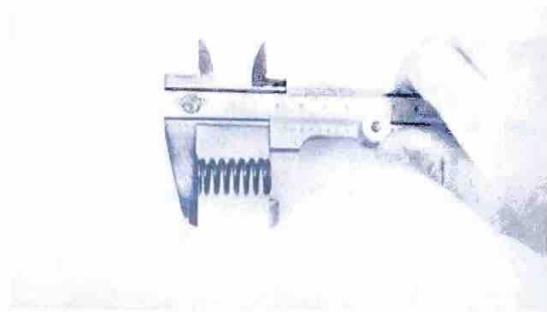

- Check the plates for signs of warpage and heat damage, replace as required.
- Measure the friction plates at three or four points. If their minimum thickness exceeds tolerance, replace.

	New	Wear limit
Friction plate thickness	3.0 mm (0.12 in)	2.7 mm (0.11 in)

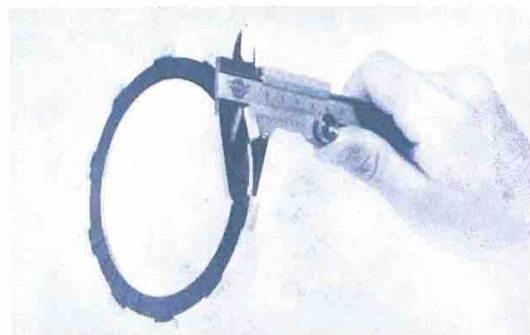

NOTE:
For optimum performance, if any plate requires replacement, it is advisable to replace the entire set.

- Check each clutch plate for signs of heat damage and warpage. Place on surface plate (plate glass is acceptable) and use feeler gauge.

Clutch plate warp allowance:
0.05 mm (0.002 in) maximum

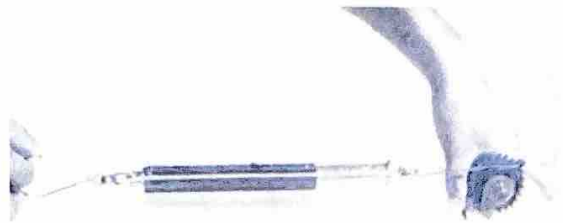

KICK STARTER

Removal

1. Remove the circlip and then remove kick idle gear and washers.

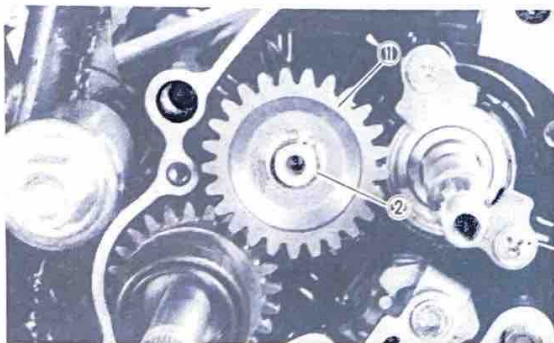

1. Kick idle gear 2. Circlip

2. Unhook the kick spring from its post in the crankcase. Allow it to relax. Then remove the kick axle assembly by rotating the shaft counterclockwise and then pulling out the entire assembly. Check the gear teeth for wear and breakage.

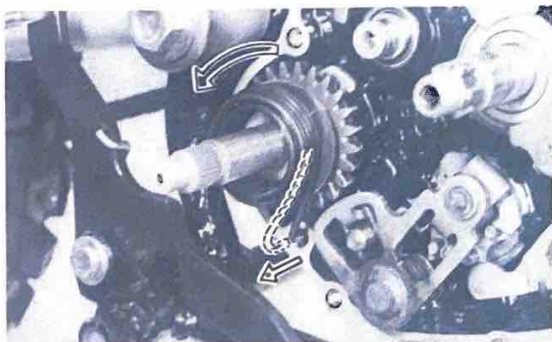

Inspection

1. The pressure of the kick clip is 1.0 kg (2.2 lb).
If above pressure is too strong, spring wear and kick starter slipping will result. If it is too weak, the same slippage will occur particularly at low temperatures. Do not try to bend the clip.

2. Check the clip for damage and wear, and determine whether or not, it should be replaced.

Reassembly

1. While keeping the kick stopper upwards, engage the kick axle return spring with the slot on the end of the kick axle. And hook the spring to the spring hook. Check whether the kick starter acts correctly and whether it returns to its home position.

en douceur ou pas.

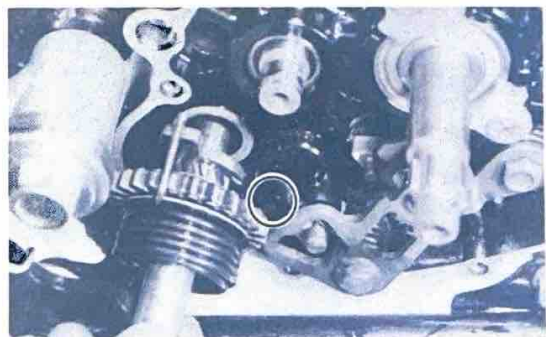

2. After installing the kick assembly be sure to check whether it operates smoothly or not.

SHIFTER

NOTE:

Shifter maintenance should be performed with clutch assembly removed.

Removal

1. Remove the change pedal and pull out the change lever assembly.
2. Shift into 2nd gear and unhook the stopper spring.
3. Remove the flange bolt, stopper lever and spring.

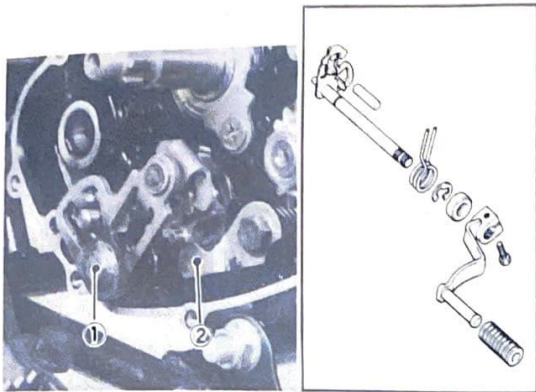

1. Change lever assembly
2. Change lever

Inspection

1. Inspect shift return spring. A broken or worn spring will impair the return action of the shifting mechanism.
2. Inspect change shaft assembly for bending of shaft, worn or bent spline, and broken or worn shift arm spring. A bent shaft will cause hard shifting.

Installation

1. Engage the shift return spring with its home position.

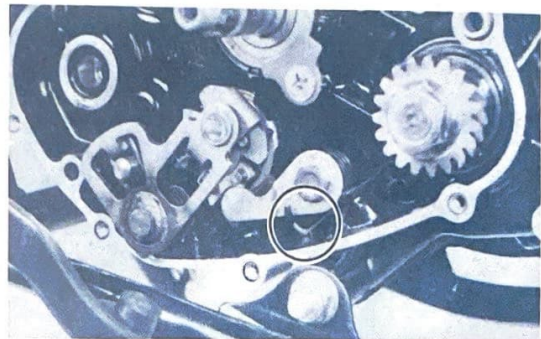
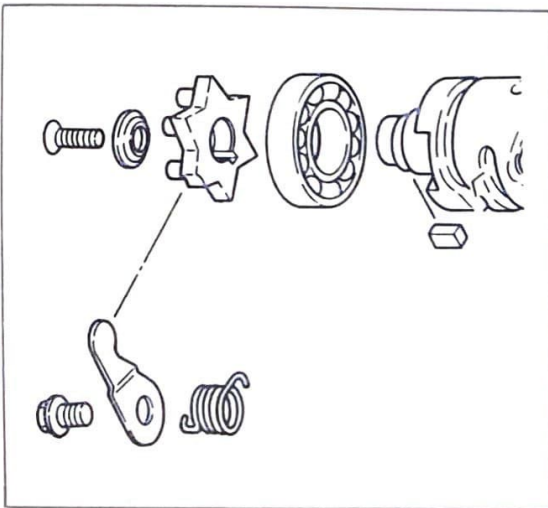

C.D.I MAGNETO

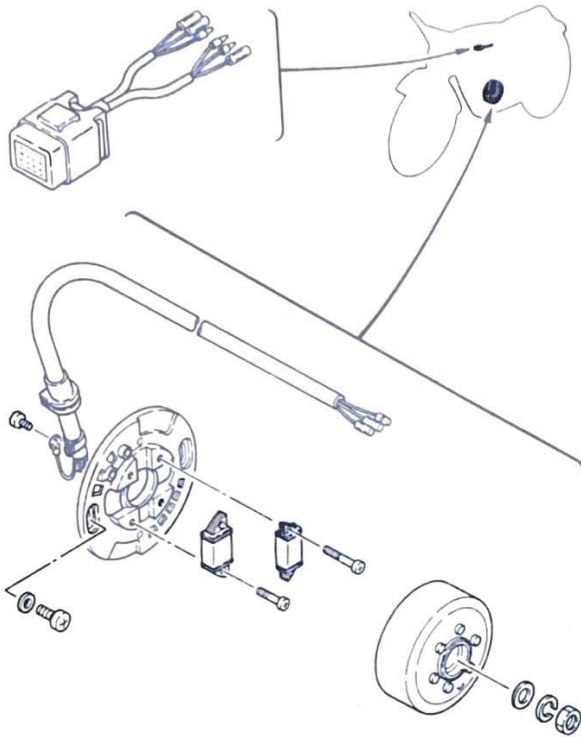

CRANKCASE

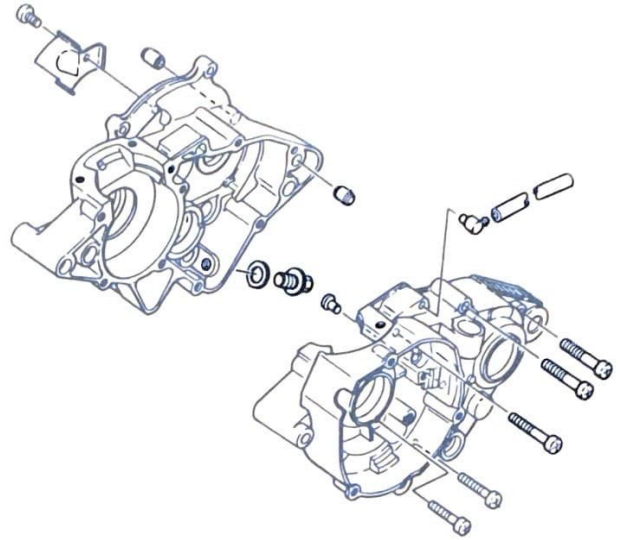

TRANSMISSION

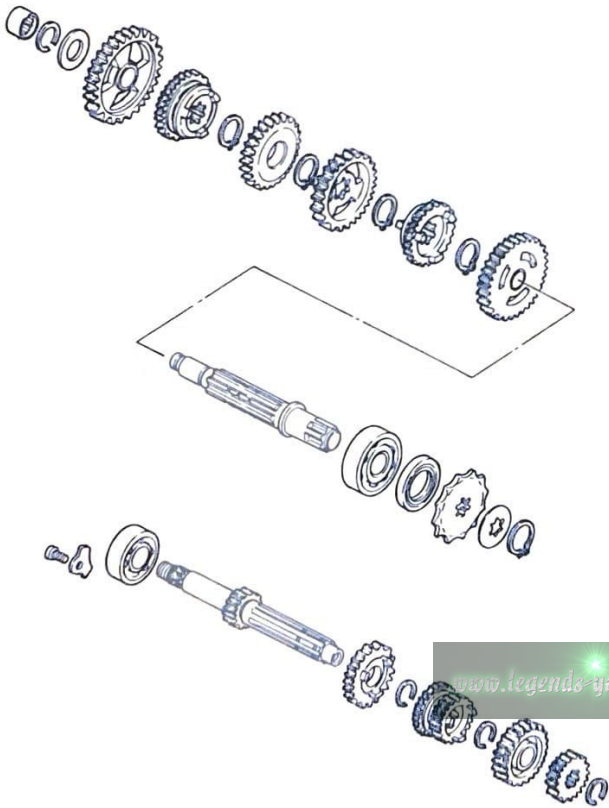

KICK STARTER

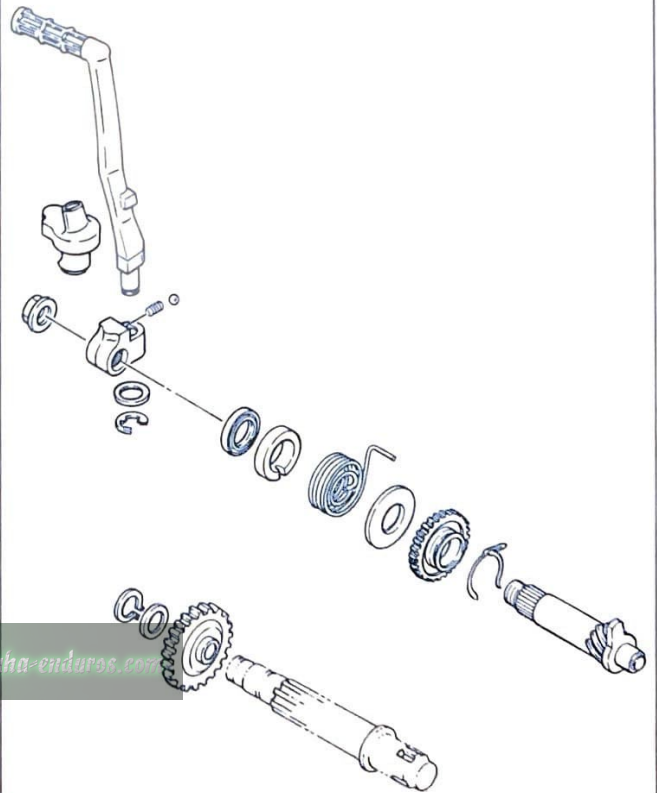

www.legends-yamaha-enduros.com

CHASSIS

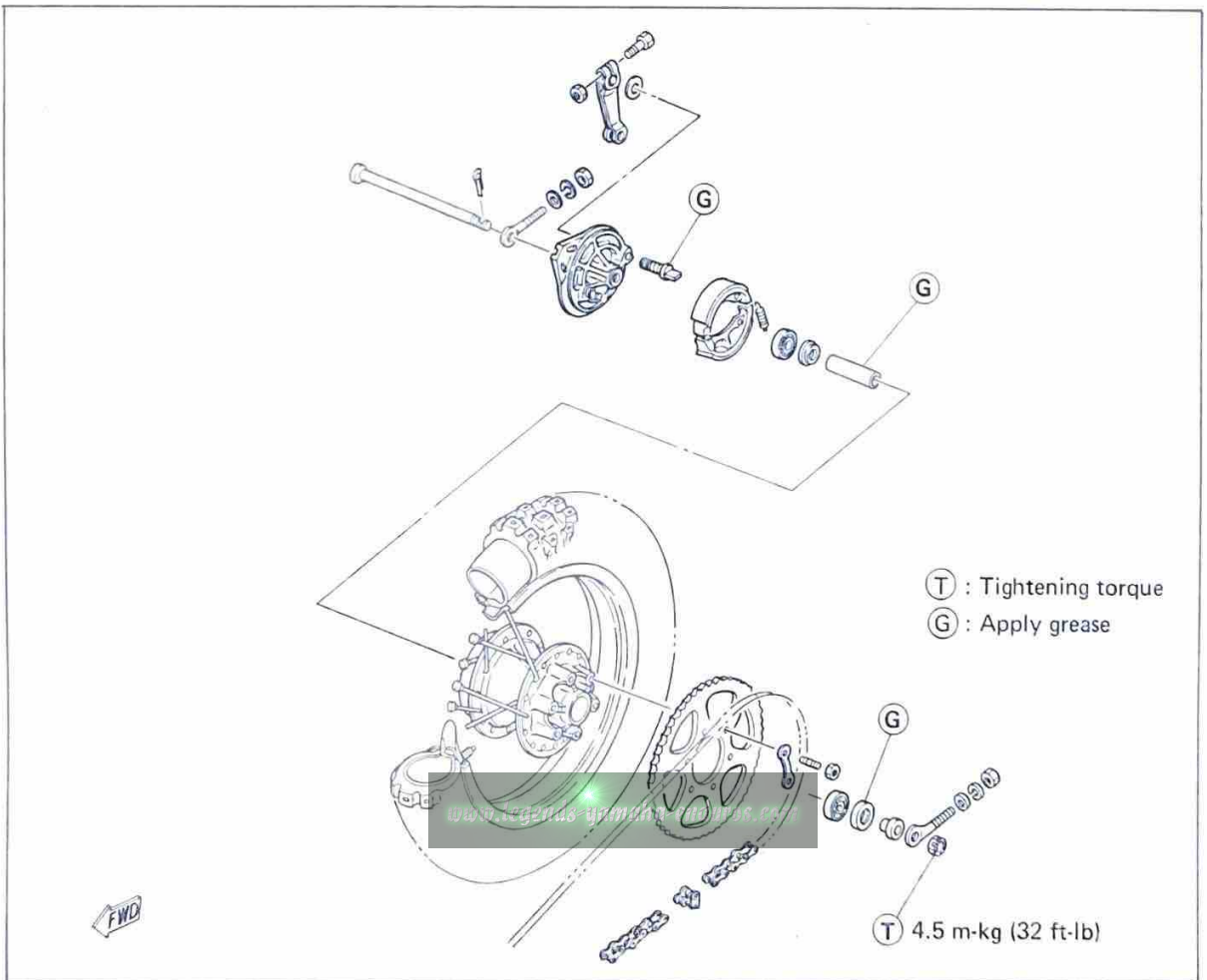
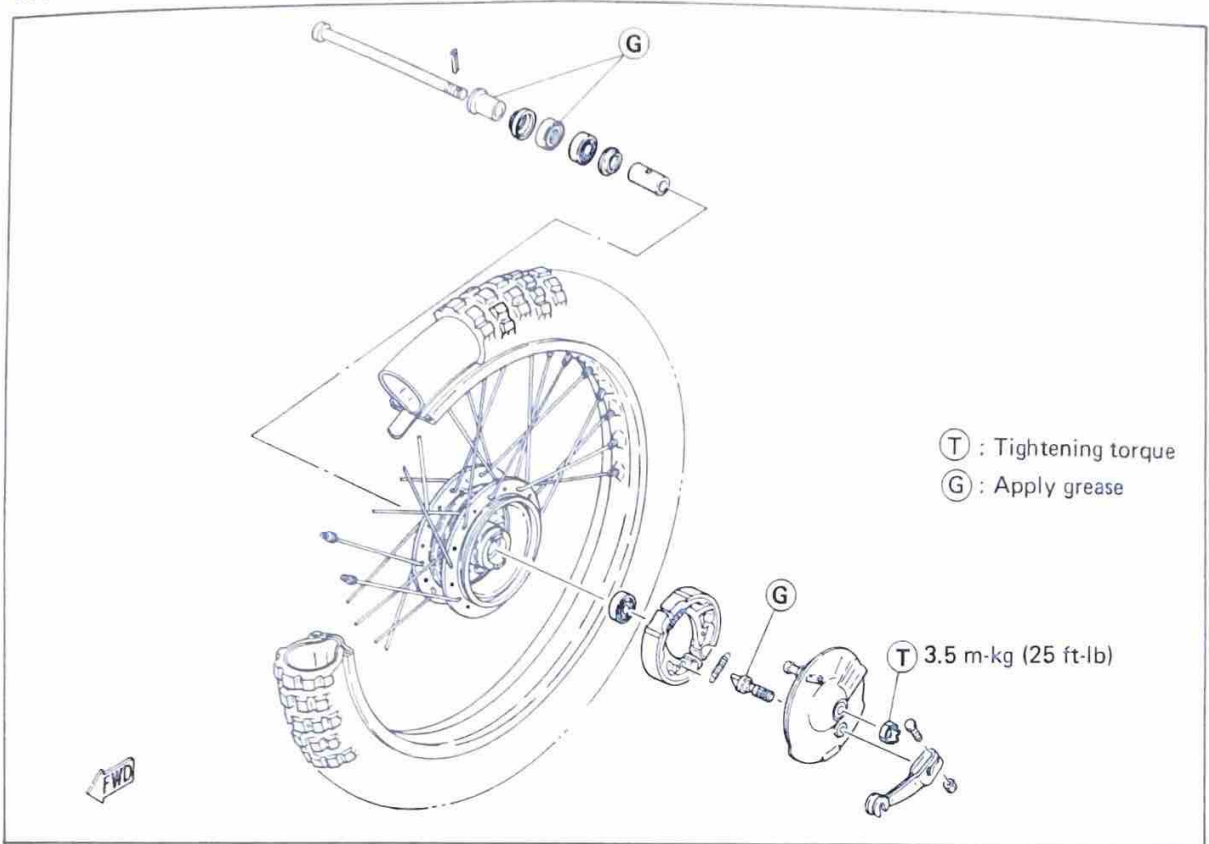

Front wheel removal

1. Elevate the front wheel by placing a suitable stand under the engine.
2. Remove brake cable: Loosen all cable adjuster screws and remove cable from handle lever holder. Then remove cable from cam lever at front brake shoe plate.
3. Remove cotter pin from front wheel axle and remove axle nut.

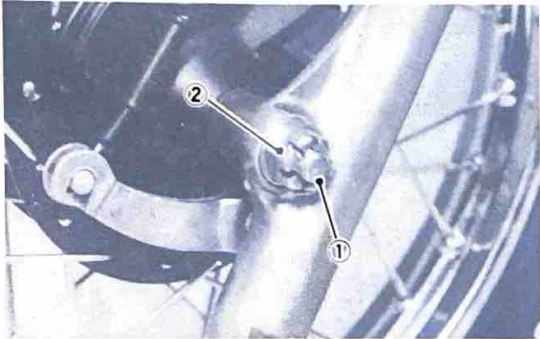

1. Cotter pin 2. Axle nut

4. Turn and pull out the front wheel axle; the wheel assembly can now be removed.

Front wheel installation

When installing front wheel, reverse the removal procedure taking the following steps:

1. Check for proper engagement of the boss on the outer fork tube with the locating slot on the brake shoe plate.
2. Insert the new cotter pin into the front wheel axle nut.

WARNING:

Always use a new cotter pin on the axle nut.



Axle nut torque: 3.5 m·kg (25 ft·lb)

Rear wheel removal

1. The brake rod can be removed by removing the adjuster.
2. Loosen the lock nuts of the right and left chain pullers and loosen the adjuster bolts.
3. Remove the master link clip and master link and remove the chain from the rear sprocket.
4. Remove the cotter pin from the wheel axle and remove the rear wheel axle nut.

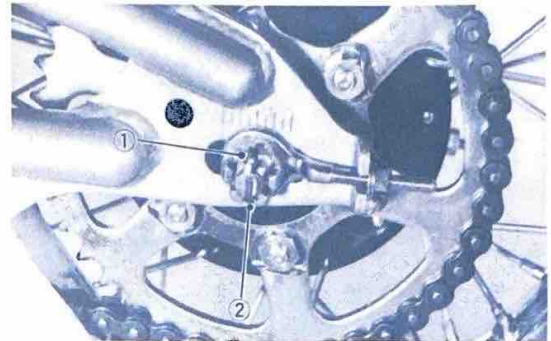

1. Cotter pin 2. Axle nut

5. The rear wheel assembly, the collar, the chain puller(s), etc., can be removed from the motorcycle by pulling the wheel axle.

Rear wheel installation

The rear wheel can be installed by reversing the removal procedure. Take the following steps.

1. Check for proper engagement of the boss on the swing arm with the locating slot on the brake shoe plate.



- When connecting the chain, make certain closed end of master link clip is facing direction of rotation.

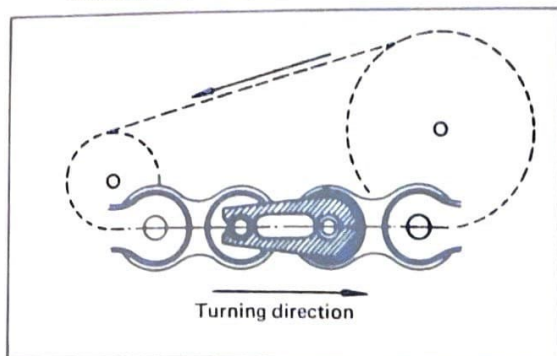

- Be sure to adjust the tension of the chain. (Refer to "Drive chain tension adjustment".)
- Insert the new cotter pin into the rear wheel axle nut.

WARNING:

Always use a new cotter pin on the axle nut.

Axle nut torque:
4.5 m·kg (32 ft·lb)

Brake shoe inspection

Measure the outside diameter of the brake shoe set with slide calipers.

If they measure less than replacement limit, replace them. Smooth out any rough spots on shoe surface with sandpaper.

	Front	Rear
Brake shoe diameter	95 mm (3.74 in)	95 mm (3.74 in)
Replacement limit	92 mm (3.62 in)	92 mm (3.62 in)

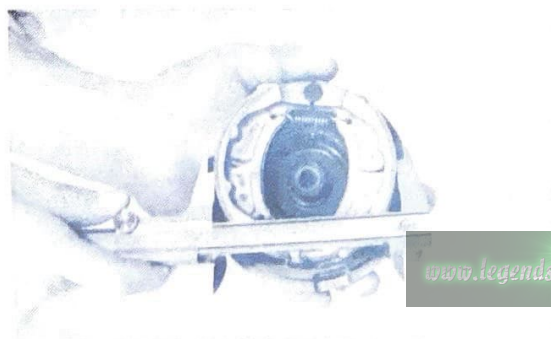

Brake drum inspection

Check the inner surface of the brake drum and remove any scratches with emery cloth. Remove any oil with a cloth dipped in sol-

vent. If damage is more extensive, have a Yamaha dealer or other qualified mechanic replace the wheel the hub.

Tire removal and tire repair

- Remove the wheel from the machine.
- Remove lock nut from valve stem and release as much air as possible from the tire.
- Push both tire beads away from the edges of the rim.
- Starting opposite the valve stem on one side, use two round-ended tire irons to work the bead off the rim.

NOTE:

Use a tire removal lubricant and be careful not to pinch the tube with the tire irons.

- Remove the valve stem from its hole and remove the tube.
- If the tire is to be changed, remove the second bead from the rim using the tire irons and tire lubricant.

Inspection

- Use a cloth to check for nails or other sharp objects in the tire.

CAUTION:

Always use a cloth to avoid cutting your hand.

- Check for faults in the side wall. If there is any fault, the tire should be replaced as a damaged tire may burst at high speeds, which is extremely dangerous.
- Inflate the tube with air and check the valve stem and the tube for damage and leakage replace as required. Some leaks can be patched in an emergency, but it is best to replace tube.

Reassembly

- Install one tire bead on the rim using tire irons and lubricant and then install the tube.

- Inflate tube wire air to about one-third the specified pressure. Hit the outer circumference of the tire with a soft hammer to make certain the tube is not caught between tire and rim. Release air from tube.
- Inspect rim band and replace if damaged.
- Install second tire bead starting opposite the valve stem using the irons and tire mounting lubricant.
- Inflate tire to approximately 3 kg/cm² (42 psi) and then reduce pressure to specified setting.

CAUTION:

Check the valve stem; it must be pointing directly at center of wheel hub. If angled in any direction, release air and adjust tube position.

Replacing wheel bearings

If the bearings allow excessive play in the wheel or if it does not turn smoothly have your dealer replace the wheel bearings.

Checking rim

- Check for cracks, bends or warpage of rim. If a rim is deformed or cracked, it must be replaced.
- Check wheel run-out
If deflection exceeds tolerance, check wheel bearing or replace wheel as required.

Rim run-out limits:
Vertical – 2.0 mm (0.08 in)
Lateral – 2.0 mm (0.08 in)

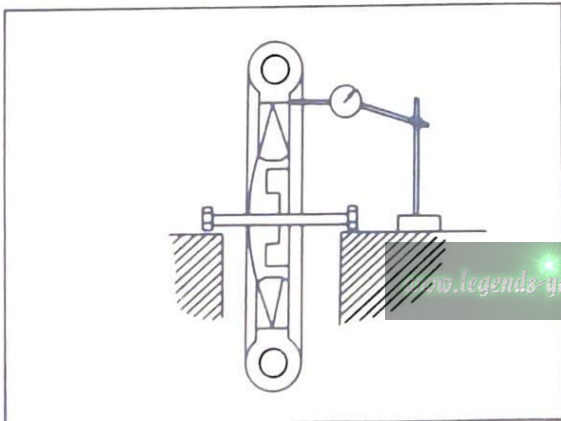

Rear shock absorber (Monocross suspension)

Removal

- Remove the side cover (R.H.)
- Remove the two bolts and remove seat.



- Remove the securing bolt and holding band from fuel tank. Lift rear of the fuel tank up and pull back to clear frame mounts. Remove tank.

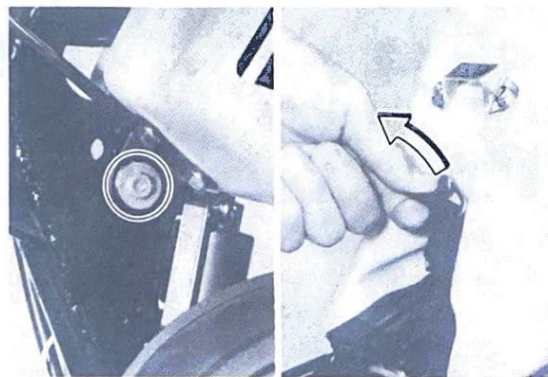

- Elevate rear wheel by placing a suitable stand under the engine.
- Remove the cotter pin. And remove the pin securing the upper bracket to frame.

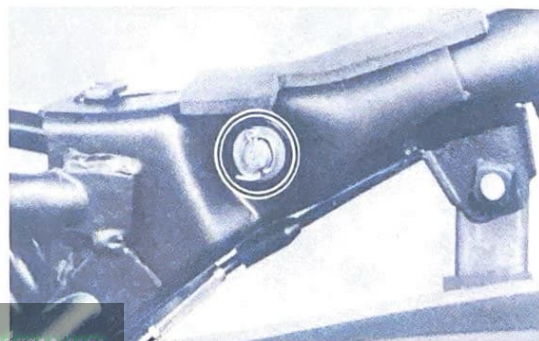

- Remove the cotter pin and remove the pin from the lower bracket.

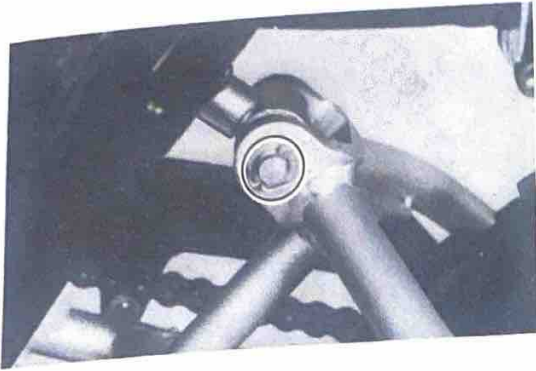

7. Remove the rear shock absorber from the frame. (To remove, pull the rear shock backward while lifting up the frame.)

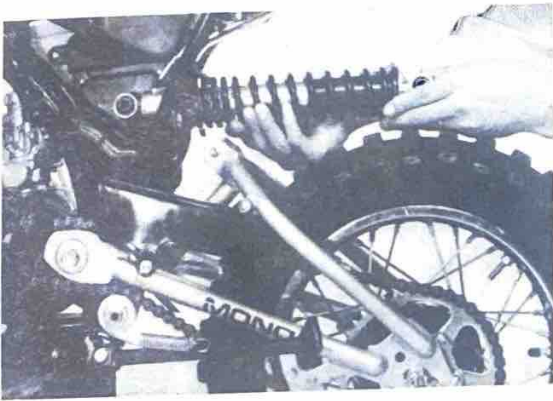

8. When reassembling, reverse the removal procedure taking care of the following points:
 - a. Always use new cotter pins.
 - b. Grease the pin and thrust cover lip.

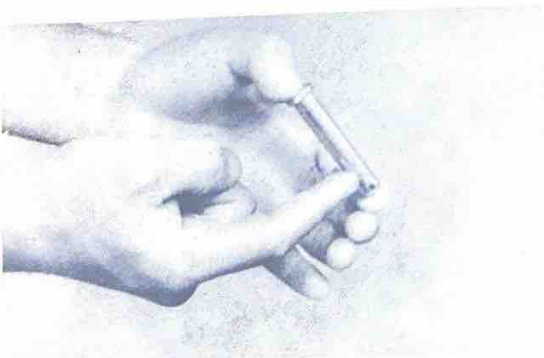

- c. Installation should be done as illustrated.

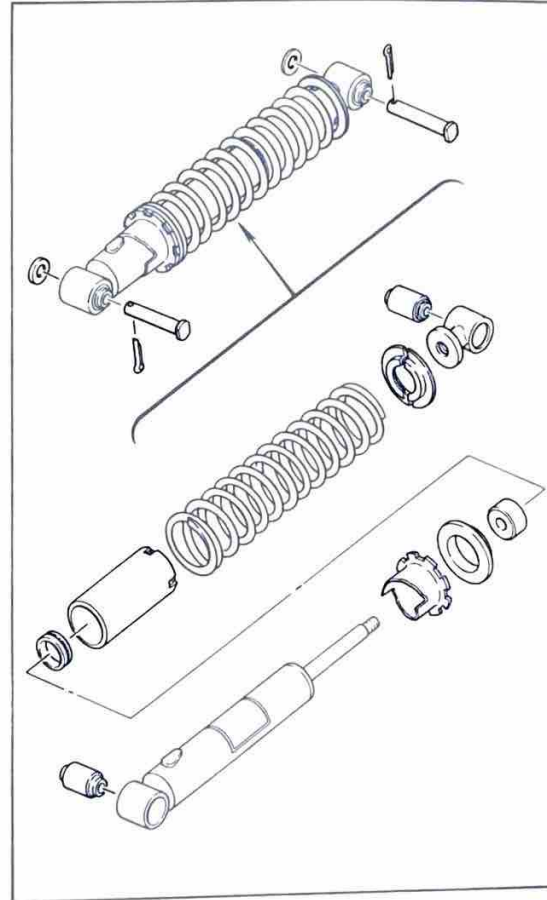
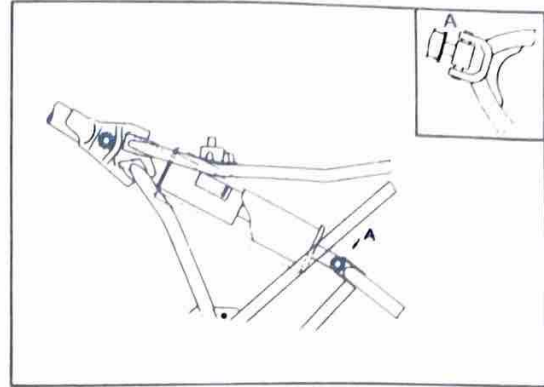

Swing arm inspection

1. With shock absorber removed, grasp the ends of the arm and move from right to left to check for free play.

Swing arm free play: 1.0 mm (0.040 in)



Cable inspection and lubrication

CAUTION:

Damage to the outer housing of the various cables, may cause corrosion and often free movement will be obstructed. An unsafe condition may result so replace as soon as possible.

1. If the inner cables do not operate smoothly, lubricate or ask your Yamaha dealer or other qualified mechanic to replace them.

Recommended lubricant:
Yamaha Chain and Cable Lube or
SAE 10W/30 motor oil

Throttle cable and grip lubrication

The throttle twist grip assembly should be greased at the time that the cable is lubricated, since the grip must be removed to get at the end of the throttle cable. Two screws clamp the throttle housing to the handlebar. Once these two are removed, the end of the cable can be held high to pour in several drops of lubricant. With the throttle grip disassembled, coat the metal surface of the grip assembly with a suitable all-purpose grease to cut down friction. (See lubrication chart.)

Lubrication of levers, pedals, etc.

1. Lubricate the pivoting parts of the brake and clutch levers with Yamaha Chain and Cable Lube or SAE 10W/30 motor oil.
2. Lubricate the shaft of the brake pedal with lithium base grease.

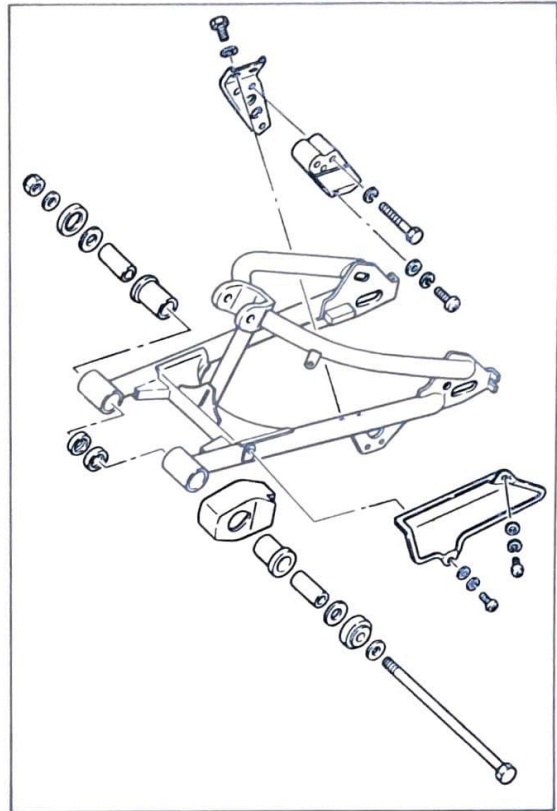

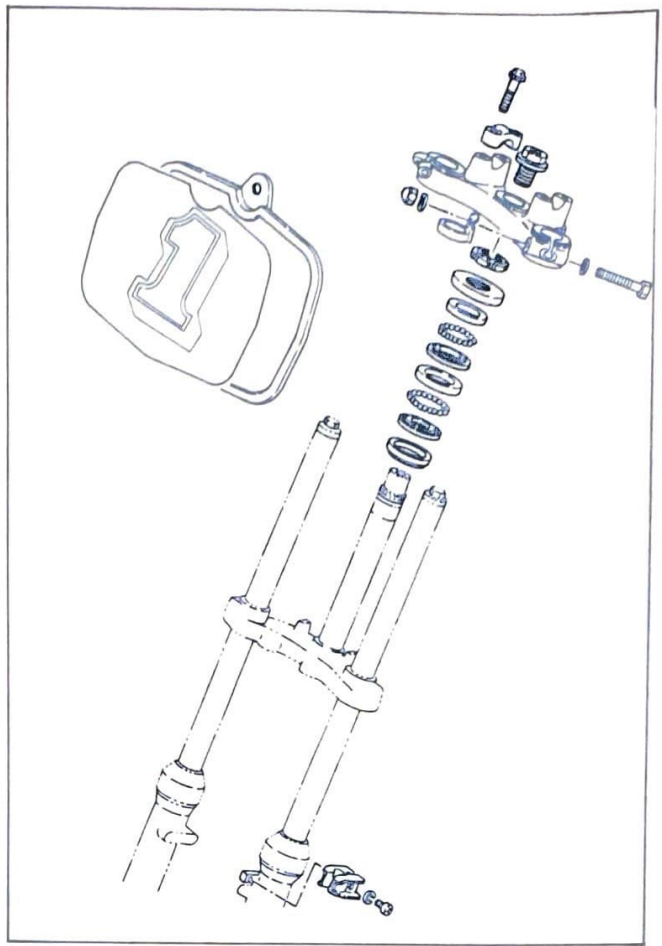
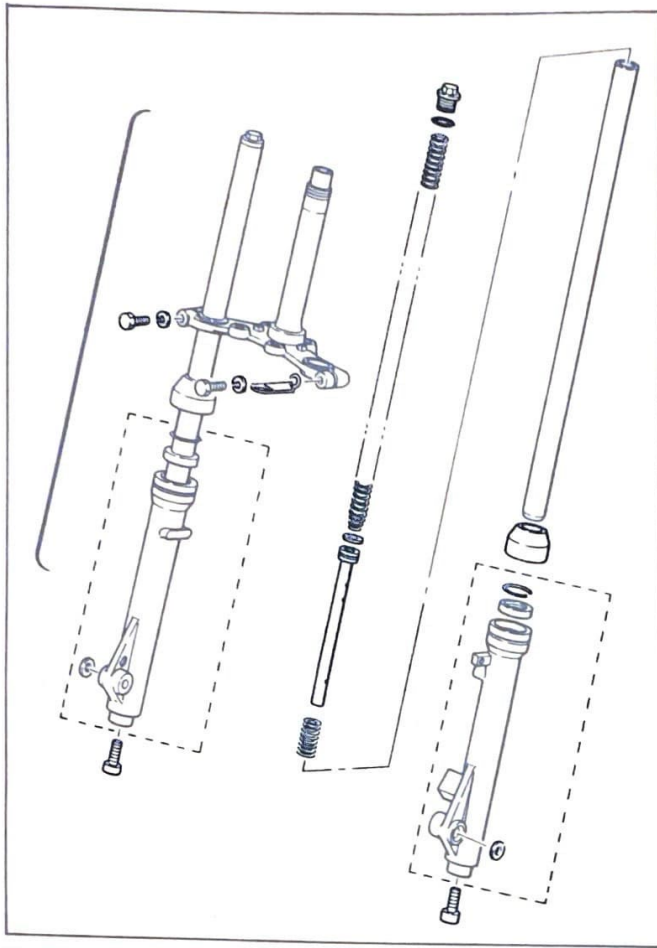

WIRING DIAGRAM

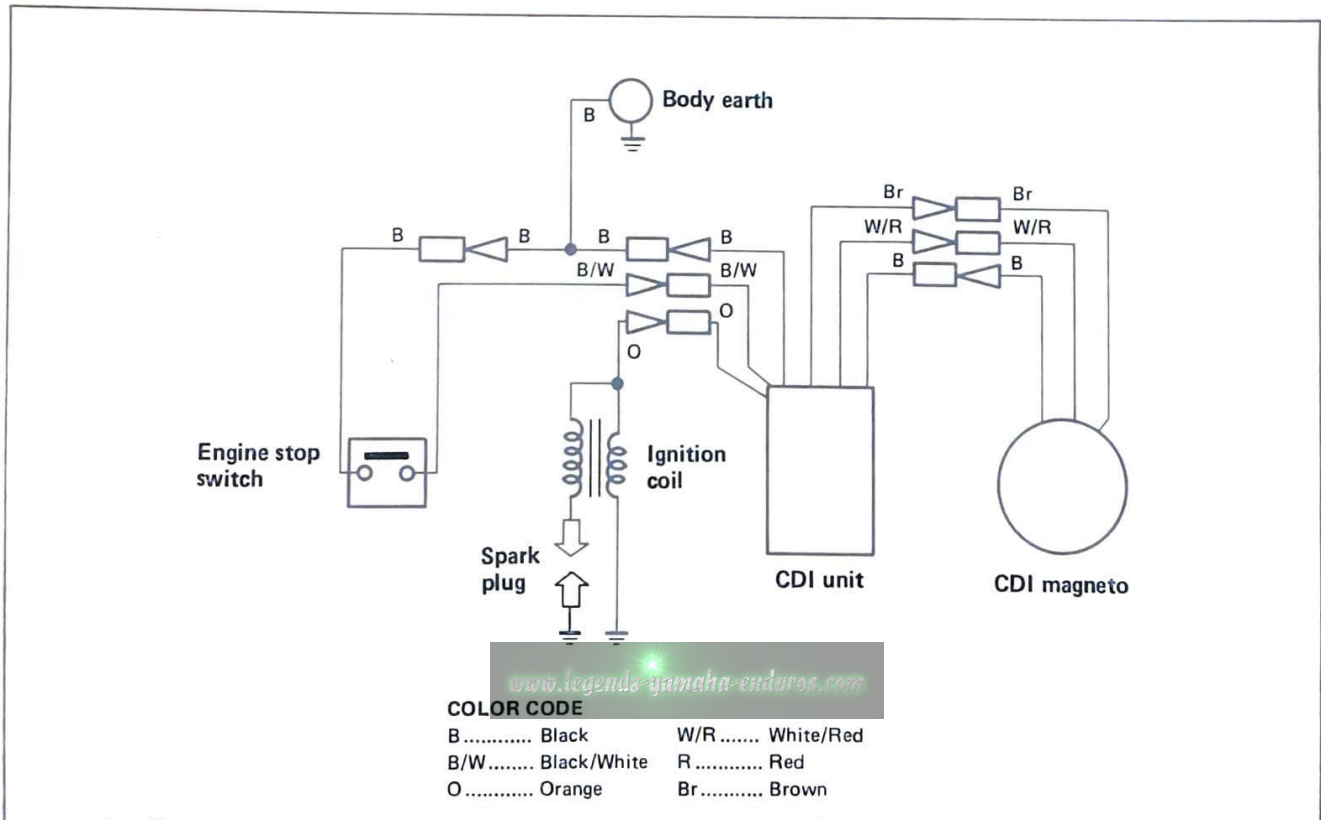

1. CDI CHECK-UP

If engine malfunction is apparently attributable to the C.D.I. system, perform check ups as per following procedure and order.

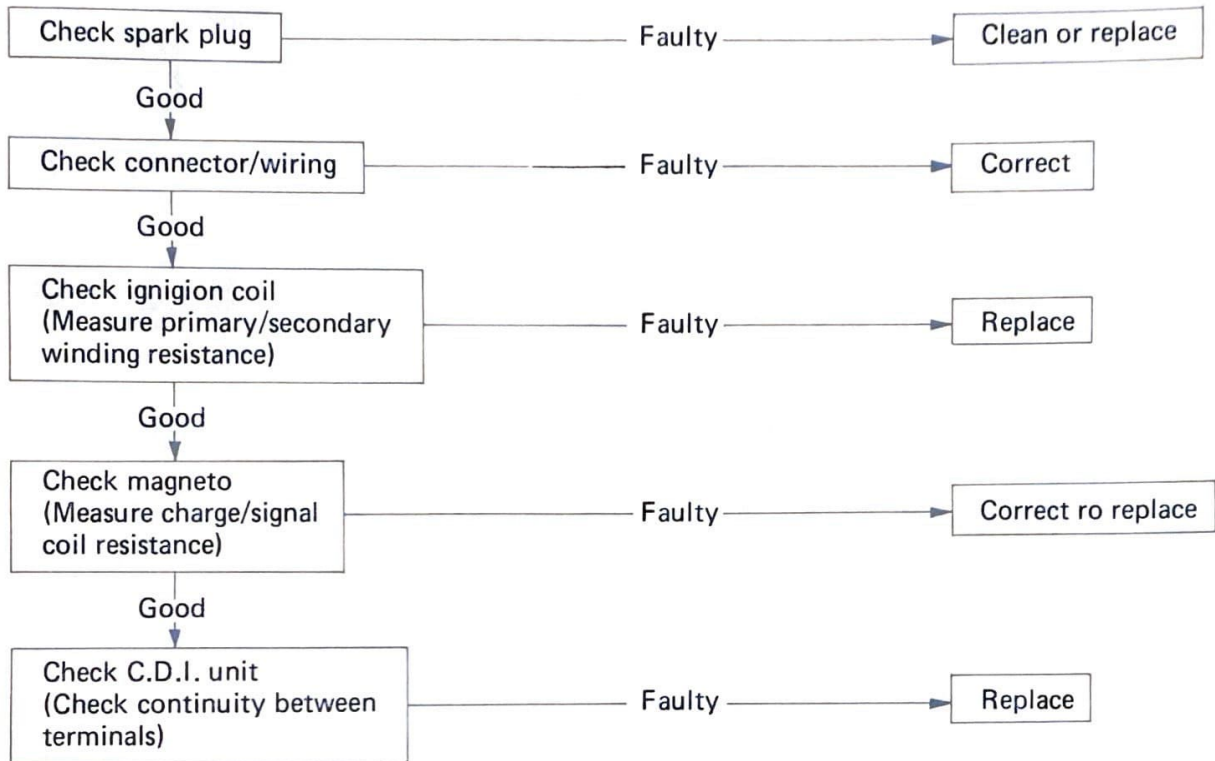

NOTE:

In the absence of sparking despite nothing wrong with the C.D.I. magneto, wiring, ignition coil, or spark plug, replace with a NEW C.D.I. unit and check.

2. CONNECTORS CHECK-UP

- Check the connectors and couplers for looseness of joining ends.
- Keep the connectors and couplers from dirt or rust.
- For secure and firm joining, take care to hold the connectors and couplers, not the wire portions, in attaching or separating them.

MISCELLANEOUS

CABLE ROUTING

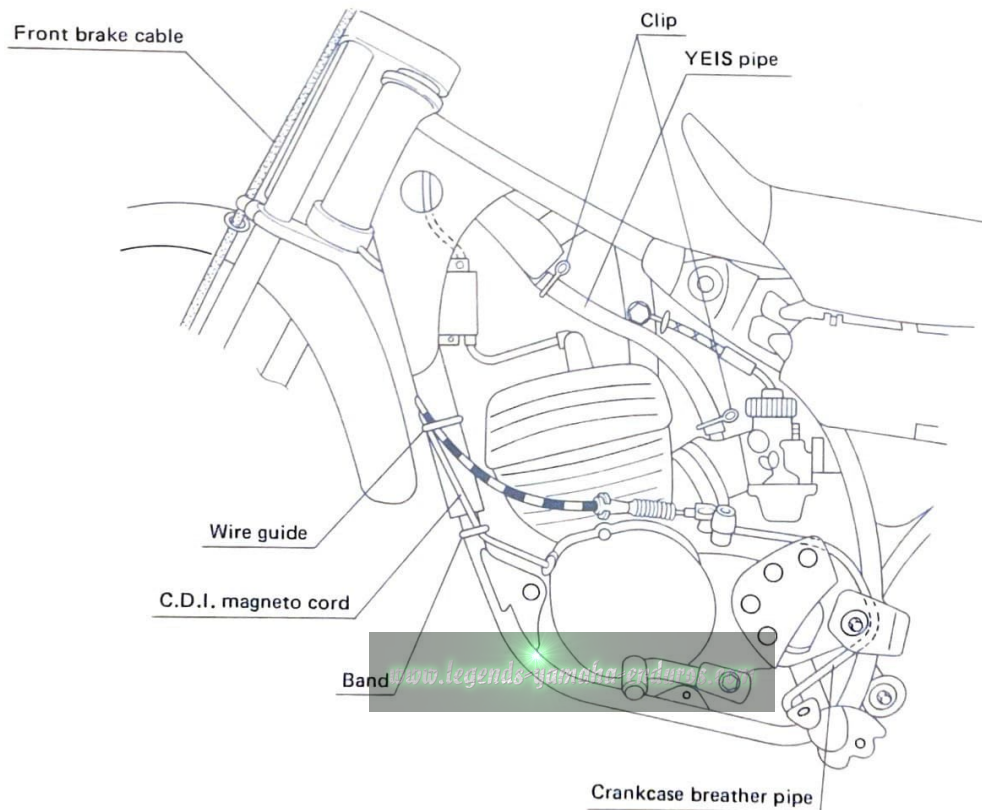
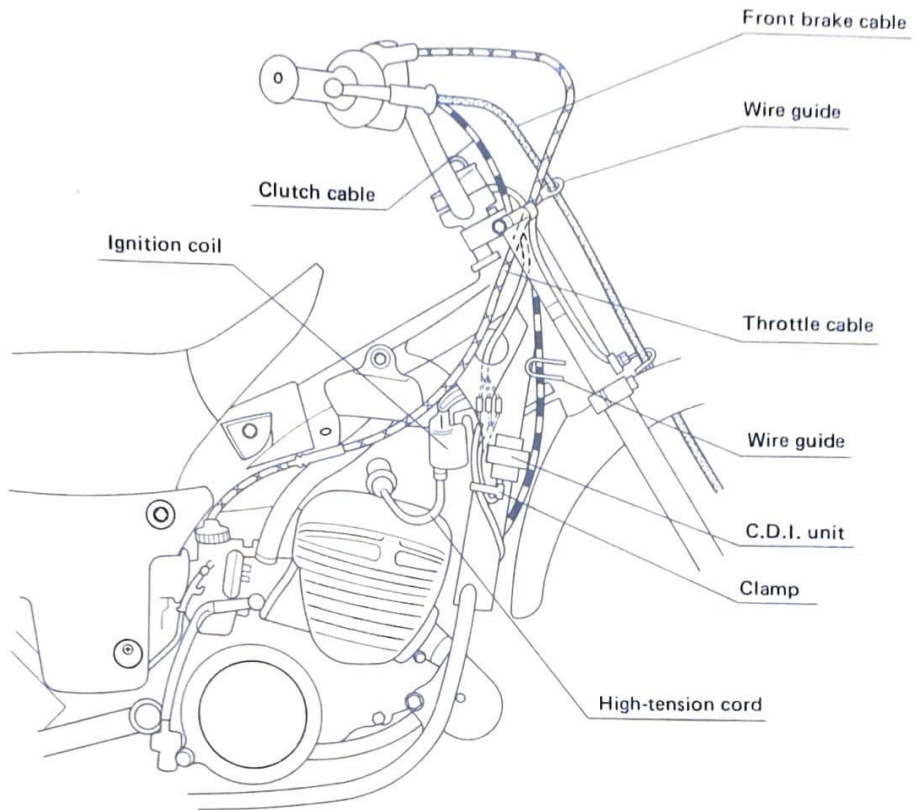

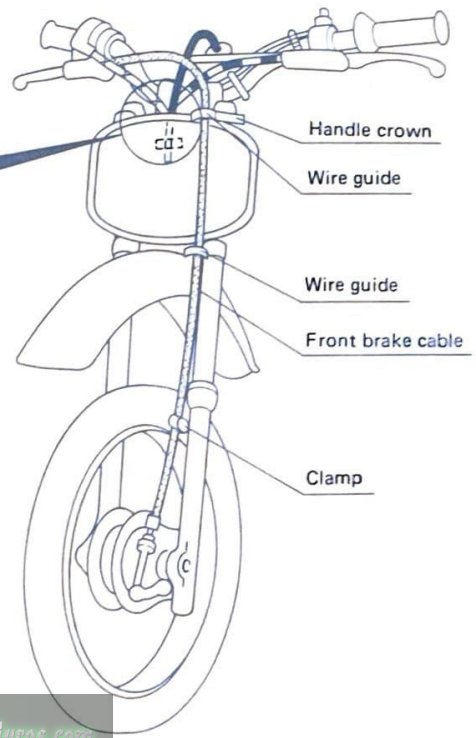
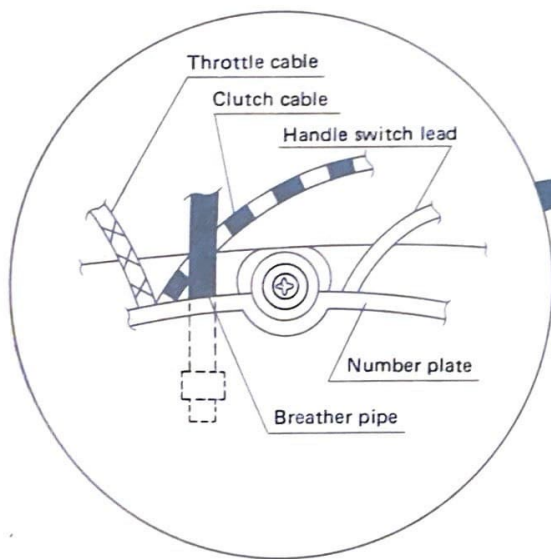
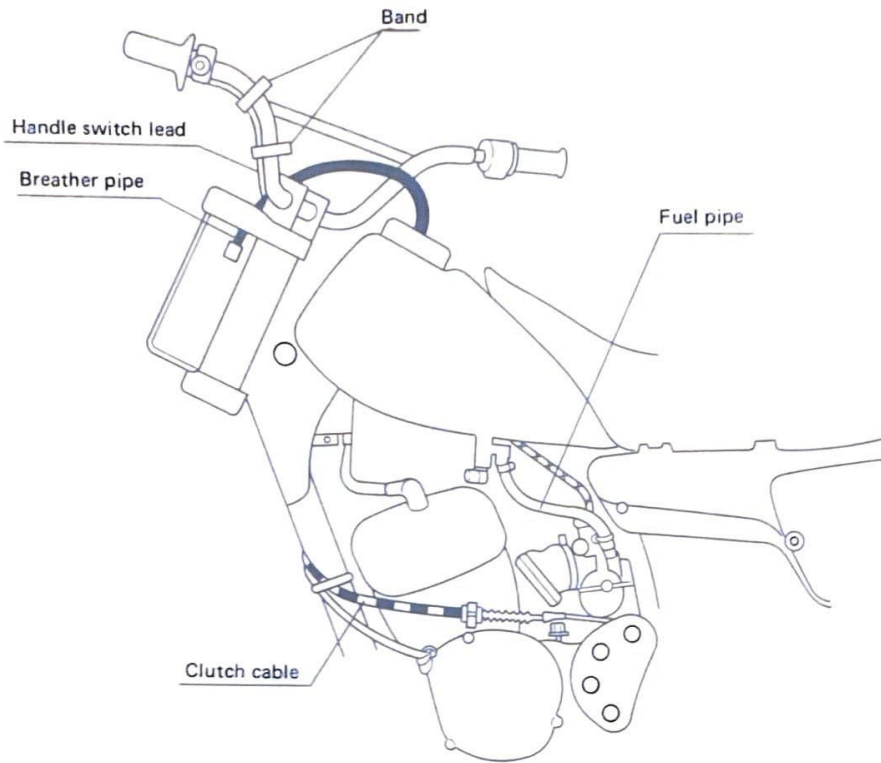

www.legends-yamaha-enduros.com

TROUBLESHOOTING

Although Yamaha machines are given a rigid inspection before shipment from the factory, trouble may occur in operation. If this happens check the machine in accordance with the procedures given in the troubleshooting chart below. If repair is necessary, ask your Yamaha dealer.

The skilled technicians at your Yamaha dealer provide excellent service. For replacement parts, use only genuine Yamaha parts. Imita-

tion parts are similar in shape but often inferior in quality of materials and workmanship; consequently, service life is shorter and more expensive repairs may be necessitated. Any fault in the fuel, compression or ignition system can cause poor starting or loss of power while riding. The troubleshooting chart describes quick and easy procedures for checking these systems.

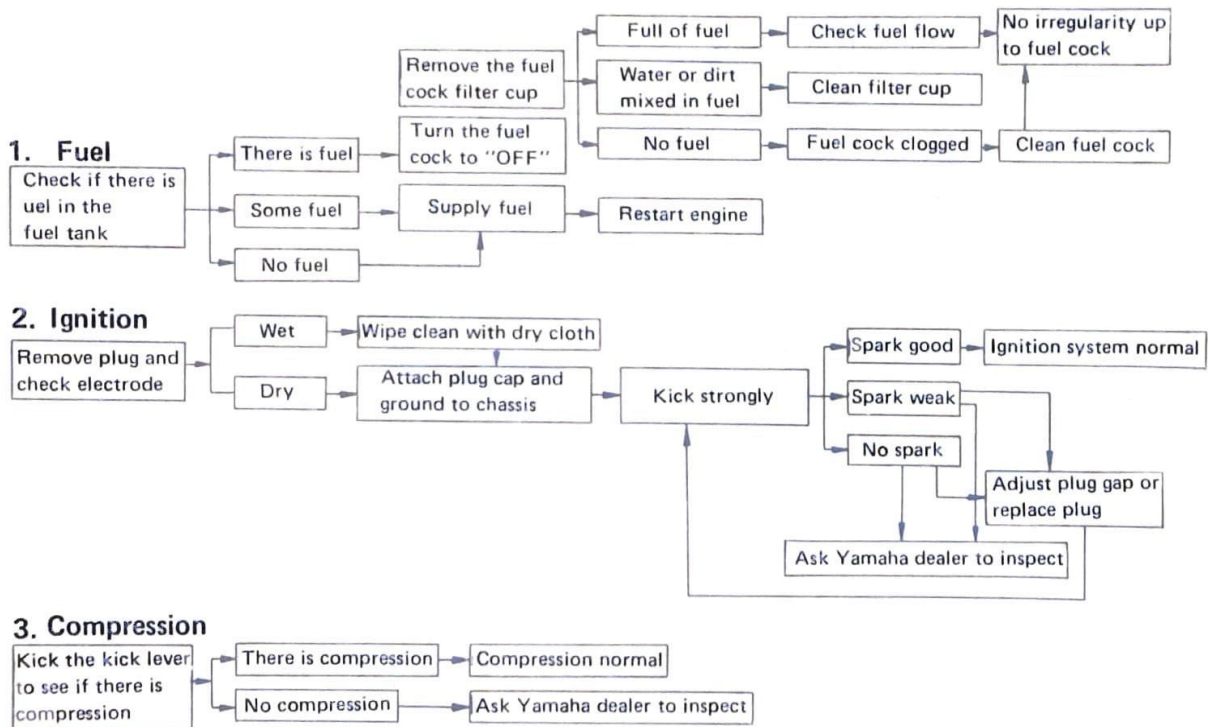

CLEANING AND STORAGE

Cleaning

Frequent thorough cleaning of your machine will not only enhance its appearance but will improve general performance and extend the useful life of many components.

1. Before cleaning the machine:
 - a. Block off end of exhaust pipe to prevent water entry; a plastic bag and strong rubber band may be used.
 - b. Remove air cleaner or protect it from water with plastic covering.
 - c. Make sure spark plug(s), fuel tank cap, transmission oil filler cap are properly installed.
2. If engine case is excessively greasy, apply degreaser with a paint brush. Do not apply degreaser to chain, sprockets, or wheel axles.
3. Rinse dirt and degreaser off with garden hose, using only enough hose pressure to do the job.

CAUTION:

Excessive hose pressure may cause water seepage and contamination of wheel bearings, front forks, brake drums, and transmission seals. Many expensive repair bills have resulted from improper high pressure detergent applications such as those available in coin-operated car washers.

4. Once the majority of the dirt has been hosed off, wash all surfaces with warm water and mild, detergent-type soap. An old tooth brush or bottle brush is handy to reach hard-to-get-to places.
5. Rinse machine off immediately with clean water and dry all surfaces with a chamois, clean towel, or soft absorbent cloth.
6. Immediately after washing, remove excess moisture from chain and lubricate to prevent rust.
7. Chrome-plated parts such as handlebars, rims, spokes, forks, etc., may be further cleaned with automotive chrome cleaner.
8. Clean the seat with a vinyl upholstery cleaner to keep the cover pliable and

glossy.

9. Automotive-type wax may be applied to all painted and chrome plate surfaces. Avoid combination cleaner-waxes. Many contain abrasive which may mar paint or protective finish on fuel and oil tanks.
10. After finishing, start the engine immediately and allow to idle for several minutes.

NOTE:

Water may enter the air cleaner case during washing the machine. Be sure to remove the grommet attached to the lower left part of the case and drain the water, as required.

Storage

Long term storage (30 days or more) of your motorcycle will require some preventive procedures to insure against deterioration. After cleaning machine thoroughly, prepare for storage as follows:

1. Drain fuel tank, fuel lines, and carburetor float bowl(s).
2. Remove the empty fuel tank, pour a cup of SAE 10W/30 oil in tank, shake the tank to coat inner surfaces thoroughly and drain off excess oil. Reinstall the tank.
3. Remove spark plug(s), pour about one tablespoon of SAE 10W/30 oil in spark plug hole(s) and reinstall spark plugs. Kick engine over several times (with ignition off) to coat cylinder walls with oil.
4. Remove drive chain. Clean thoroughly with solvent and lubricate. Re-install chain or store in a plastic bag (tie to frame for safe-keeping).
5. Lubricate all the control cables.
6. Block up frame to raise both wheels off ground.
7. Tie a plastic bag over exhaust pipe outlet(s) to prevent moisture from entering.
8. If storing in humid or salt-air atmosphere, coat all exposed metal surfaces with a light film of oil. Do not apply oil to rubber parts or seat cover.

NOTE:

Make any necessary repairs before storing the machine.

SPECIFICATIONS

General

Item	Model	YZ60J
Model:		
Model (I.B.M. No.)	5X1	
Frame I.D. & Starting Number	5X1-000101	
Engine I.D. & Starting Number	5X1-000101	
Dimensions:		
Overall length	1,550 mm (61.0 in)	
Overall width (standard)	715 mm (28.1 in)	
Overall height (standard)	930 mm (36.6 in)	
Seat height	670 mm (26.4 in)	
Wheelbase	1,065 mm (41.9 in)	
Minimum ground clearance	215 mm (8.5 in)	
Basic weight:		
With oil and full fuel tank	55 kg (121 lb)	

Engine

Description:	
Engine type	Air cooled 2-stroke gasoline torque induction
Engine model	5X1
Displacement	58 cc (3.54 cu.in)
Bore x Stroke	42 x 42 mm (1.65 x 1.65 in)
Compression ratio	7.6 : 1
Starting system	Primary kick starter
Ignition system	Magneto
Lubrication system	Mixed gas (24 : 1) (YAMALUBE R)
Cylinder head:	
Combustion chamber volume	4.9 cc (0.3 cu.in)
Combustion chamber type	Special squish
Head gasket thickness	0.5 mm (0.02 in)
Cylinder:	
Material	Cast iron sleeve with aluminium
Bore size	42 ⁺⁰ _{+0.02} mm (1.65 ⁺⁰ _{+0.0008} in)
Taper limit	0.05 mm (0.002 in)
Out of round limit	0.01 mm (0.004 in)
Piston:	
Piston skirt clearance	0.055 ~ 0.060 mm (0.0022 ~ 0.0024 in)
Piston oversize	42.25, 42.50, 42.75, 43.00 mm (1.585, 1.594, 1.604, 1.614 in)
Piston pin outside diameter x Length	12 x 35 mm (0.47 x 1.34 in)
Piston ring:	
Piston ring design (Top/Second)	Plain ring
Ring end gap (Installed) (Top/Second)	0.15 ~ 0.35 mm (0.006 ~ 0.014 in)
Ring groove side clearance (Top)	0.04 ~ 0.08 mm (0.002 ~ 0.003 in)
Ring groove side clearance (Second)	0.02 mm (0.0008 in)
Small end bearing: Type	Needle (12 x 16 x 14.8 mm)
Big end bearing: Type	Needle (18 x 24 x 14 mm)

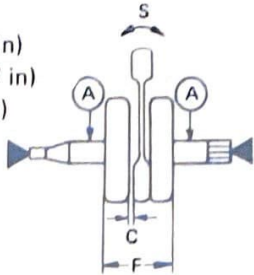
<p>Crankshaft:</p> <p>Crankshaft assembly width (F)</p> <p>Crankshaft deflection (A)</p> <p>Connecting rod big end side clearance (C)</p> <p>Connecting rod small end deflection (S)</p> <p>Crank pin outside diameter x Length</p> <p>Crank pin type</p> <p>Crank bearing type (Left)</p> <p>(Right)</p> <p>Crank oil seal type (Left)</p> <p>(Right)</p>	<p>45^{-0.05}_{-0.10} mm (1.77^{-0.002}_{-0.004} in)</p> <p>0.03 mm (0.0012 in)</p> <p>0.2 ~ 0.7 mm (0.08 ~ 0.028 in)</p> <p>0.5 ~ 1.2 mm (0.019 ~ 0.047 in)</p> <p>18 x 43.6 mm (0.71 x 1.72 in)</p> <p>Hollow type</p> <p>6204</p> <p>6204</p> <p>SD-20-40-8-GS</p> <p>MHSD-28-40-8</p> 
<p>Clutch:</p> <p>Clutch type</p> <p>Clutch operating mechanism</p> <p>Primary reduction ratio & method</p> <p>Friction plate – Thickness/Quantity</p> <p>– Wear limit</p> <p>Clutch – Thickness/Quantity</p> <p>– Warp limit</p> <p>Clutch spring – Free length/Quantity</p> <p>– Wear limit</p> <p>Clutch housing axial play (wear limit)</p> <p>Push rod bending limit</p>	<p>Wet, multiple disc type</p> <p>Inner push type, cam axle</p> <p>68/19, 3.578 Helical gear</p> <p>3.0 mm (0.12 in) x 4 pcs.</p> <p>2.7 mm (0.11 in)</p> <p>1.2 mm (0.05 in) x 3 pcs.</p> <p>0.05 mm (0.002 in)</p> <p>30.1 mm (1.19 in) x 4 pcs.</p> <p>29.1 mm (1.15 in)</p> <p>0.1 ~ 0.35 mm (0.004 ~ 0.014 in)</p> <p>0.15 mm (0.006 in)</p>
<p>Transmission:</p> <p>Type</p> <p>Gear ratio 1st (Teeth) (Ratio)</p> <p>2nd</p> <p>3rd</p> <p>4th</p> <p>5th</p> <p>6th</p> <p>Transmission gear oil capacity & type</p> <p>Secondary reduction ratio & method</p>	<p>Constant mesh, 6-speed</p> <p>36/13 (2.769)</p> <p>33/16 (2.062)</p> <p>31/19 (1.631)</p> <p>28/21 (1.333)</p> <p>23/20 (1.150)</p> <p>25/24 (1.042)</p> <p>Total = 700 ~ 750 cc (0.74 ~ 0.80 US qt)</p> <p>Exchange = 650 ~ 700 cc (0.69 ~ 0.74 US qt)</p> <p>YAMALUBE 4-cycle oil or SAE 10W/30</p> <p>“SE” motor oil</p> <p>42/13 (3.231) chain</p>
<p>Intake:</p> <p>Air cleaner – Type/Quantity</p> <p>– Oil grade</p> <p>Induction system</p>	<p>Wet-form rubber/1 pc.</p> <p>SAE 10W/30 “SE” motor oil</p> <p>Reed valve</p>
<p>Reed valve:</p> <p>Type</p> <p>Bending limit</p> <p>Valve lift</p>	<p>V type</p> <p>0.3 mm (0.012 in) or less</p> <p>9 mm (0.35 in)</p>
<p>Carburetor:</p> <p>Type & Manufacturer/Quantity</p> <p>I.D. Mark</p> <p>Main jet (M.J.)</p> <p>Air jet (A.J.)</p> <p>Jet needle-clip position (J.N.)</p> <p>Needle jet (N.J.)</p> <p>Cutaway (C.A.)</p> <p>Pilot jet (P.J.)</p> <p>Air screw (turns out) (A.S.)</p> <p>Starter jet (G.S.)</p> <p>Float height (F.H.)</p>	<p>VM24SS, MIKUNI/1 pc.</p> <p>5X100</p> <p>#200</p> <p>1.0</p> <p>4K4-3</p> <p>O-4</p> <p>#30</p> <p>1 and 1/4</p> <p>20</p> <p>21.0 ± 1 mm (0.83 ± 0.039 in)</p>

Chassis

Frame: Frame design Steering system: Caster Trail Number & size of balls in steering head: Upper race Lower race Lock to lock angel	Tubular steel, semi double cradle 26° 60 mm (2.36 in) 3/16 in x 22 pcs. 1/4 in x 19 pcs. Each 47°
Front suspension: Type Damper type Front fork travel Front fork springs: Free length Inner tube outside diameter Oil seal type Front fork oil capacity & type	Telescopic fork Coil spring, oil damper 165 mm (6.5 in) 467.5 mm (18.41 in) 26 mm (1.1 in) SD26-37-10.5 79.1 cc (2.7 US oz) per each (Yamaha fork oil 20 wt, SAE 20W motor oil)
Rear suspension: Type Gas pressure Gas properties Absorber stroke Wheel travel Compression spring: Free length Set length Number of windings Spring diameter Spring O.D. Swing arm free play	Monocross (DE CARBON SYSTEM) 16 kg/cm ² (227 lb/in ²) Nitrogen gas 76 mm (3.0 in) 178 mm (7.0 in) 235 mm (9.3 in) 215 mm (8.5 in) 16.7 turns 7.7 mm (0.3 in) 53.4 mm (2.1 in) 1.0 mm (0.04 in)
Fuel tank: Capacity Fuel grade	3.3 liter (0.9 US gal) Mixed gas 24 : 1 (Premium gasoline: YAMALUBE "R")
Wheel: Tire size (Front) (Rear) Tire pressure (STD) (Front) (Rear) Rim size (Front) (Rear) Rim run out limit (Front/Rear) – Vertical – Lateral Secondary drive chain type: Type Number of links Chain free play	2.50–14–4PR 3.00–12–4PR 1.0 kg/cm ² (14 psi) 1.0 kg/cm ² (14 psi) 1.40 x 14 1.60 x 12 2 mm (0.08 in) 2 mm (0.08 in) DK420 97L + Joint 5 ~ 10 mm (0.20 ~ 0.39 in)

Brake:	
Front brake:	
Type	Leading, trailing
Drum diameter	95 mm (3.74 in)
Shoe diameter x Width	95 x 20 mm (3.74 x 0.79 in)
Shoe spring free length	32.7 mm (1.29 in)
Lining thickness/Wear limit	3 mm/1.5 mm (0.12 in/0.06 in)
Rear brake:	
Type	Leading, trailing
Drum diameter	95 mm (3.74 in)
Shoe diameter x Width	95 x 20 mm (3.74 x 0.79 in)
Shoe spring free length	32.7 mm (1.29 in)
Lining thickness/Wear limit	3 mm/1.5 mm (0.12 in/0.06 in)

Electrical

Ignition system:	
Type	CDI magneto
Model/Manufacturer	F3T-80371
Charge coil resistance	420Ω ± 10% (Brown–Black)
Pulser coil resistance	12Ω ± 10% (White/Red–Black)
Ignition timing (B.T.D.C.):	18° at 10,000 r/min (1.0 ± 0.15 mm/0.071 ± 0.006 in)
Ignition coil:	
Model/Manufacturer	F6T411/Mitsubishi
Spark gap	6 mm (0.24 in) or more
Primary winding resistance	1Ω at 20°C
Secondary winding resistance	5.9kΩ at 20°C
Spark plug:	
Type/Manufacturer	N-2 (CHAMPION)
Spark plug gap	0.7 ~ 0.8 mm (0.028 ~ 0.031 in)
CDI unit:	
Type/Manufacturer	F8T02371/Mitsubishi

Tightening torque

		Specified torque
Engine:		
Cylinder head	M8	3.0 m-kG (21 ft-lb)
Spark plug	M14	2.5 m-kG (18 ft-lb)
Carburetor joint	M6	1.0 m-kG (7 ft-lb)
Crankcase	M6	0.8 m-kG (6 ft-lb)
Crankcase cover	M6	0.8 m-kG (6 ft-lb)
Bearing plate cover	M6	0.8 m-kG (6 ft-lb)
Drain plug	M12	2.0 m-kG (14 ft-lb)
Kick crank	M6	1.2 m-kG (8 ft-lb)
Primary drive gear	M12	6.5 m-kG (46 ft-lb)
Clutch boss	M12	5.0 m-kG (36 ft-lb)
Clutch spring	M5	0.6 m-kG (4 ft-lb)
Rotor	M10	4.0 m-kG (28 ft-lb)
Stator	M6	0.8 m-kG (6 ft-lb)
Drive gear	M12	6.0 m-kG (43 ft-lb)
Chassis:		
Front wheel axle	M10	3.5 m-kG (26 ft-lb)
Front fender	M6	0.6 m-kG (4 ft-lb)
Brake cam lever	M6	1.0 m-kG (7 ft-lb)
Handle crown — Steering	M14	6.0 m-kG (43 ft-lb)
— Inner tube	M8	1.6 m-kG (12 ft-lb)
— Handle holder	M8	1.6 m-kG (12 ft-lb)
Engine mounts	M8	2.4 m-kG (17 ft-lb)
Pivot shaft	M12	5.0 m-kG (36 ft-lb)
Footrest bracket	M10	5.0 m-kG (36 ft-lb)
Rear wheel axle	M12	4.5 m-kG (32 ft-lb)
Rear hub stud	M8	3.0 m-kG (21 ft-lb)
Driven sprocket	M8	2.6 m-kG (18 ft-lb)
Fuel tank fittings	M6	0.6 m-kG (4 ft-lb)
Side stand	M8	2.0 m-kG (14 ft-lb)
Rear fender	M6	0.6 m-kG (4 ft-lb)
Chain case	M5	0.3 m-kG (2 ft-lb)

WARRANTY INFORMATION

STATEMENT OF PURCHASER'S RESPONSIBILITY

This (model) Yamaha motorcycle is sold AS IS, WITHOUT ANY WARRANTIES EXPRESSED OR IMPLIED REGARDLESS OF THE INTENDED USE.

THE PURCHASER OF THIS MOTORCYCLE, which is intended for competition purposes, IS RESPONSIBLE FOR ALL COSTS OF SERVICE AND/REPAIR.



www.legends-yamaha-enduro.com

YAMAHA MOTOR CO., LTD.

IWATA, JAPAN

PRINTED IN U.S.A.