

# YAMAHA

## PARTS CATALOGUE

**YZ80L** (39K)

(80 CM<sup>3</sup>)

1439K-100E1

[www.legends-yamaha-enduros.com](http://www.legends-yamaha-enduros.com)

**A2**

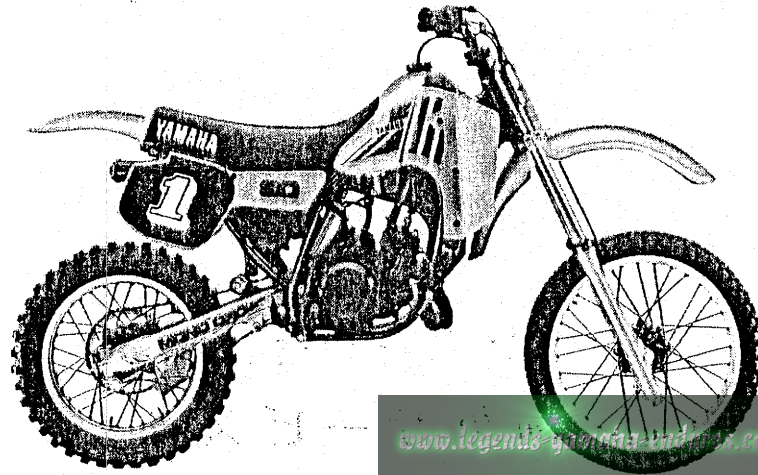
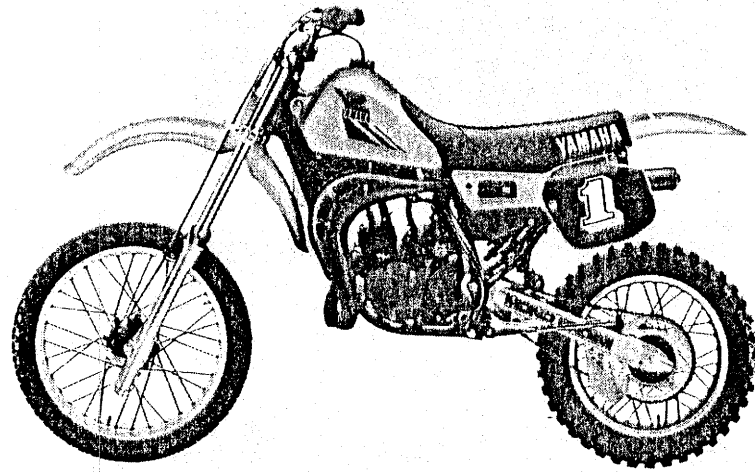

[www.legends-yamaha-riders.com](http://www.legends-yamaha-riders.com)

A3

# FOREWORD

This Parts Catalogue is related to the parts in use for the Yamaha YZ 80L (39K).

When you are ordering replacement parts for the YZ 80L (39K), refer to this Parts Catalogue and quote both part numbers and part names correctly.

1. Modifications or additions which have been made after issue of the Parts Catalogue will be announced in the Yamaha Parts News.

It is advisable that according to the Yamaha Parts News you make necessary corrections to the Parts Catalogue on hand to keep it up-to-date.

2. Abbreviations

The following abbreviations are used in this Parts Catalogue.

- U.R. Use size (thickness) and/or number as required.
- U.N. Use as many as you need.
- A.P. Alternate Parts
- L.M. Local Made
- F# Frame No. (Applicable machine No.)

3. The parts marked with (+) in the parts number column of this Catalogue are not supplied with by Yamaha, those have to be found locally.

4. Parts, which are to be supplied in the form of assemblies, are listed with an indention of one letter's space, and a dot ( . ) is put against the name of each part.

**EXAMPLE** CARBURETOR ASS'Y  
 . JET, pilot  
 . NOZZLE, main

5. Indication of No. of constituent parts for assembly

The numeral appearing to the right of each constituent part under the description indicates the quantity of such parts for each individual assembly unit.

**EXAMPLE**

Part No.	Description	Q'ty	Remarks
2F5-83310-60	FRONT FLASHER LIGHT ASS'Y	2	
115-83311-60	. BULB (6V-18W)	1	
1M1-83309-60	. REFLECTOR	1	

6. Initial Serial No. and Color Code

(A) Frame Serial No.	39K-000101 and following
(B) Engine Serial No.	39K-000101 and following

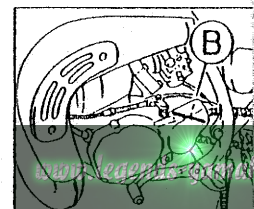
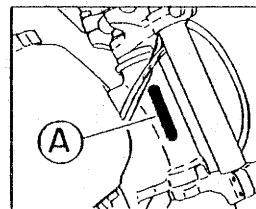

Color Code	Color Name	Abbreviate
26	Competition Yellow	CPY
36	Clean White	W

7. Applicable colors of graphics are represented in the "Remarks" column by the letter(s) appropriately picked out of the full word(s) showing such colors.

**EXAMPLE**

Part No.	Description	Q'ty	Remarks
2N4-24110-00-X5	FUEL TANK COMP.	1	MAXIM RED
3J1-24240-10	. GRAPHIC, fuel tank set	1	for MXR

# CONTENTS

## ENGINE

Cylinder Head .....	B2
Crankshaft · Piston .....	B3
Water Pump .....	B4
Radiator Hose .....	B5
Intake .....	B6 ~ B7
Carburetor .....	B8
Exhaust .....	B9
Crankcase .....	B10
Crankcase Cover 1 .....	B11
Starter .....	B12
Clutch .....	B13
Transmission .....	B14
Shift Cam · Fork .....	B15
Shift Shaft .....	C2

## CHASSIS

Frame .....	C3
Fender .....	C4
Side Cover .....	C5
Rear Arm .....	C6 ~ C7
Rear Suspension .....	C8 ~ C9
Steering .....	C10
Front Fork .....	C11 ~ C12
Fuel Tank .....	C13 ~ C14
Seat .....	C15
Front Wheel .....	D2
Rear Wheel .....	D3 ~ D4
Steering Hand · Cable .....	D5
Stand · Footrest .....	D6 ~ D7

Generator .....	D8
Handle Switch · Lever .....	D9
Electrical 1 .....	D10

## ALTERNATE PARTS

Alternate (Chassis) .....	D11
---------------------------	-----

## REPAIR KIT

Repair Kit .....	D12
------------------	-----

## INDEX

Numerical Index .....	L1 ~ L3
Parts Name Index .....	M1 ~ M4

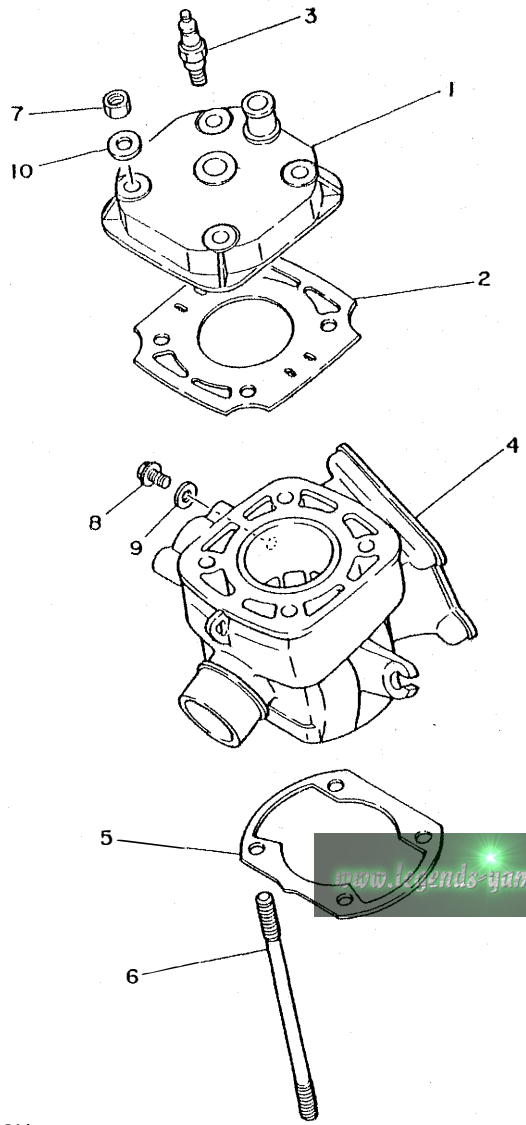

FIG. 1 CYLINDER HEAD

REF. NO.	PART NO.	DESCRIPTION	Q'TY	REMARKS
1	39K-11111-00	HEAD, cylinder 1	1	
2	39K-11181-00	GASKET, cylinder head 1	1	
3	*	PLUG, spark (CHAMPION QN-84)	1	UR LM for Canada
	*	PLUG, spark (CHAMPION N-84)	1	UR LM for U.S.A
4	39K-11311-00	CYLINDER 1	1	
5	4V0-11351-00	GASKET, cylinder	1	
6	90116-08438	BOLT, stud	4	
7	95311-08600	NUT	4	
8	90153-06045	SCREW, hexagon	1	
9	90430-06166	GASKET	1	
10	90201-08649	WASHER, plate	4	

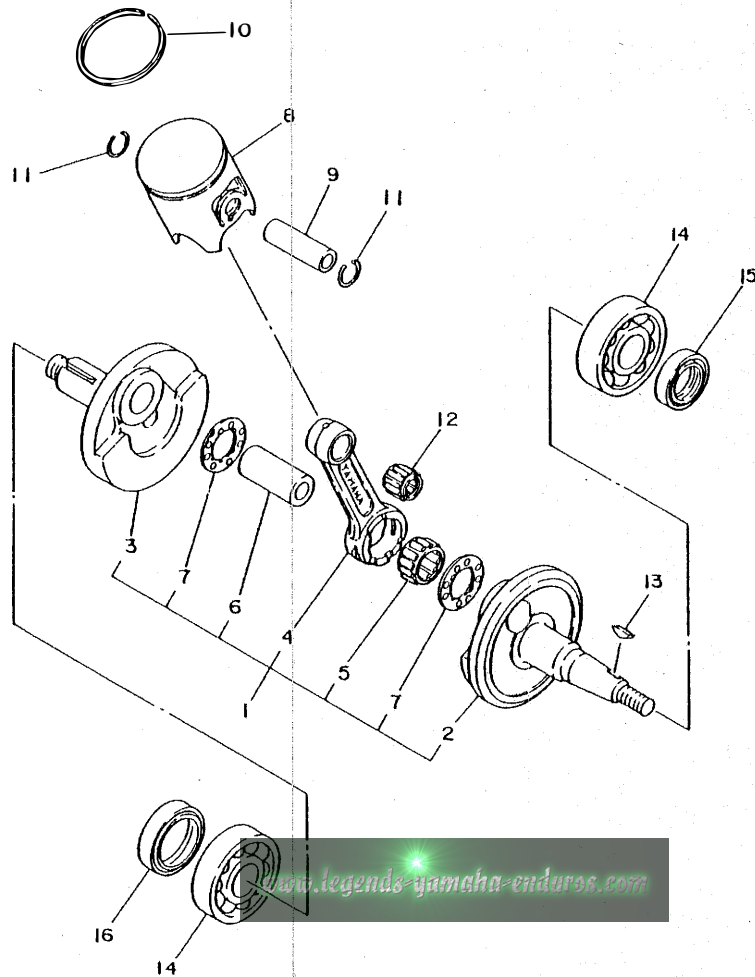

FIG. 2 CRANKSHAFT, PISTON

REF. NO.	PART NO.	DESCRIPTION	Q'TY	REMARKS
1	39K-11400-00	CRANKSHAFT ASSY	1	
2	39K-11412-00	.CRANK 1	1	
3	39K-11422-00	.CRANK 2	1	
4	39K-11651-00	.ROD, connecting	1	
5	93310-418M6	.BEARING, cylindrical	1	
6	4V0-11681-00	.PIN, crank 1	1	
7	90209-18112	.WASHER	2	
8	39K-11631-00-94	PISTON (STD)	1	UR
	39K-11631-00-95	PISTON (STD)	1	UR
	39K-11635-00	PISTON (0.25MM O/S)	1	AP
	39K-11636-00	PISTON (0.50MM O/S)	1	AP
9	4V1-11633-00	PIN, piston	1	
10	39K-11611-00	RING, piston	1	
	39K-11611-10	RING, piston	1	AP
	39K-11611-20	RING, piston	1	AP
11	5X2-11634-00	CLIP, piston pin	2	
12	93310-312M5	BEARING, cylindrical	1	
13	90280-03017	KEY, woodruff	1	
14	93306-20438	BEARING	2	
15	93102-20231	OIL SEAL	1	
16	93103-28126	OIL SEAL	1	



22W100-3020

B3

FIG. 3 WATER PUMP

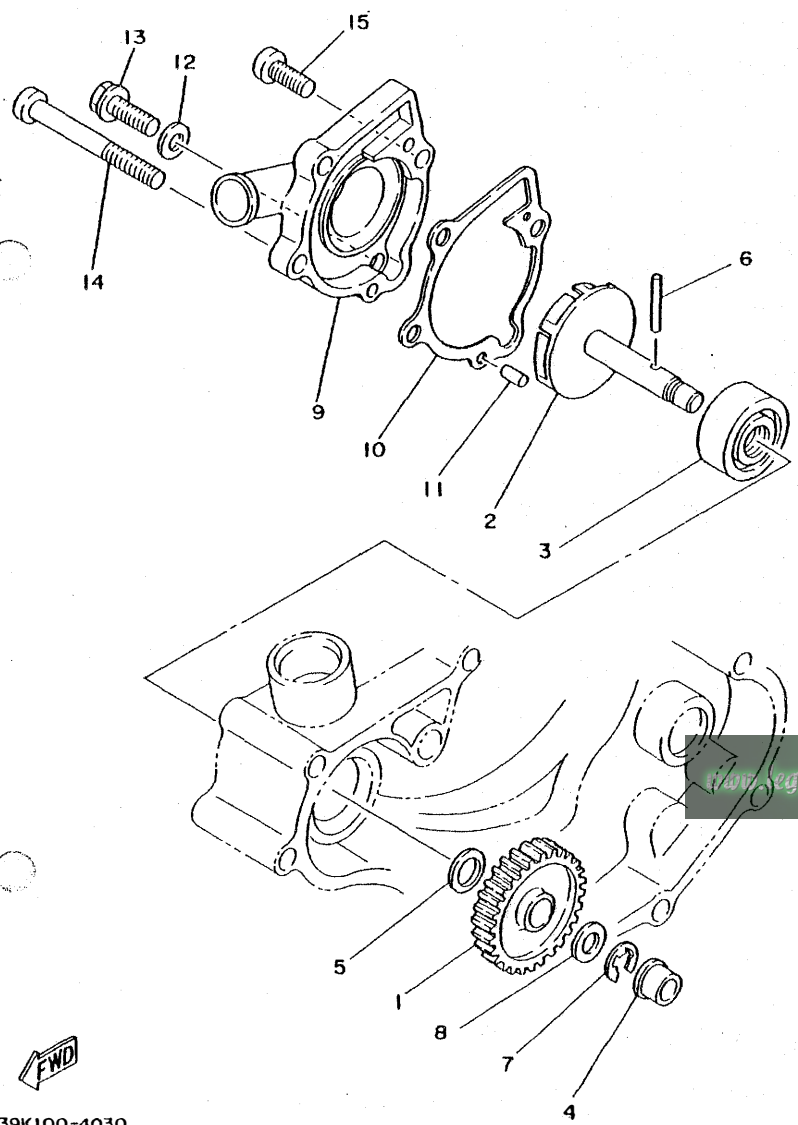

REF. NO.	PART NO.	DESCRIPTION	Q'TY	REMARKS
1	39K-12459-00	GEAR, impeller shaft	1	
2	22W-12450-00	IMPELLER SHAFT ASSY	1	
3	93103-10113	OIL SEAL	1	
4	90381-08002	BUSH, solid	1	
5	90201-10614	WASHER, plate	1	
6	93603-22028	PIN, dowel	1	
7	93430-07012	CIRCLIP	1	
8	90201-08085	WASHER, plate	1	
9	39K-12422-00	COVER, housing	1	
10	5X2-12428-00	GASKET, housing cover 2	1	
11	93604-10011	PIN, dowel	2	
12	90430-06166	GASKET	1	
13	95826-06020	BOLT, flange	1	
14	92506-06060	SCREW, pan head	2	
15	92506-06020	SCREW, pan head	1	

[www.legends-yamaha-enduros.com](http://www.legends-yamaha-enduros.com)



39K100-4030

**B4**

FIG. 4 RADIATOR. HOSE

REF. NO.	PART NO.	DESCRIPTION	Q'TY	REMARKS
1	39K-12460-00	RADIATOR ASSY	1	
2	22W-12462-00	.CAP, radiator	1	
3	22W-12463-00	PIPE, breather	1	
4	90467-08004	CLIP	1	
5	39K-12481-00	PIPE 1	1	
6	39K-12482-00	PIPE 2	1	
7	90460-31253	CLAMP, hose	2	
8	90460-22252	CLAMP, hose	2	
9	39K-12446-00	JOINT	1	
10	92506-06016	SCREW, pan head	2	
11	93210-16275	O-RING	2	
12	4V2-12494-00	SEAL, pipe 1	1	
13	90201-06570	WASHER, plate	2	
14	90119-06080	BOLT, with washer	2	
15	90480-15064	GROMMET	2	
16	90387-07392	COLLAR	2	
17	22W-24181-00	DAMPER, locating 1	2	

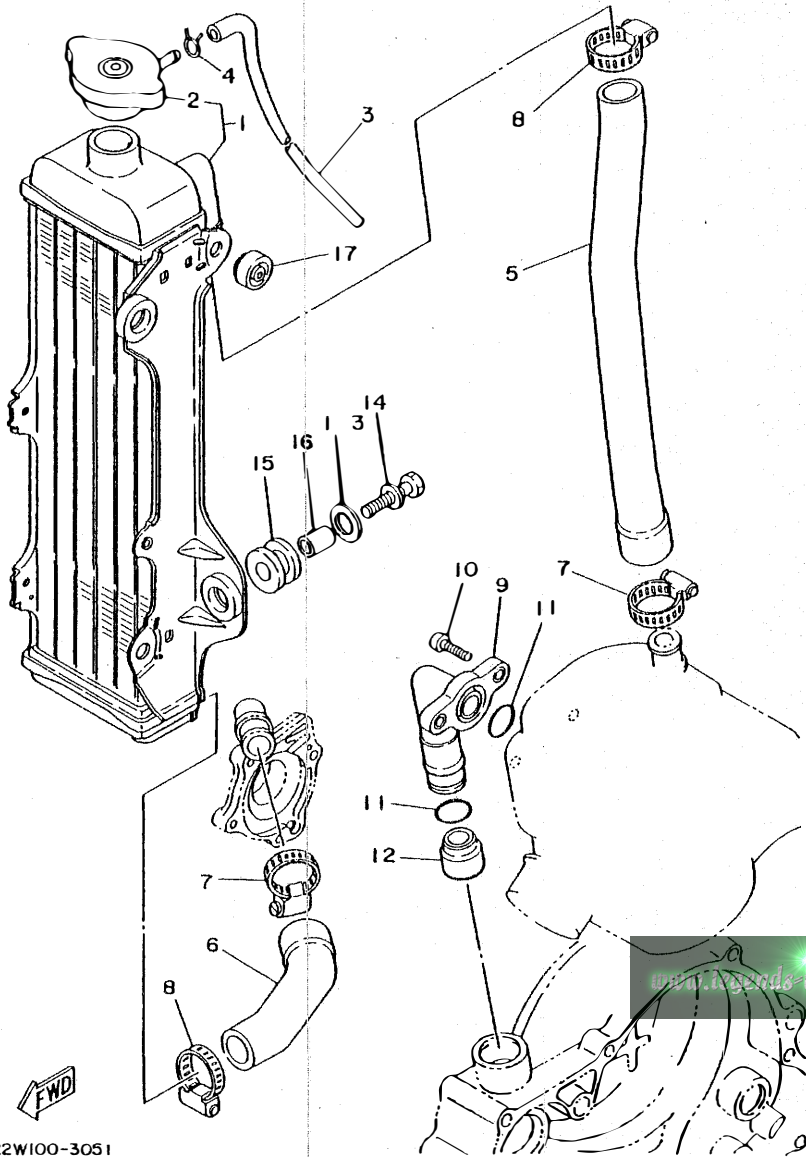

FWD

22W100-3051

B5



FIG. 5 INTAKE

REF. NO.	PART NO.	DESCRIPTION	Q'TY	REMARKS
1	22W-13610-00	REED VALVE ASSY	1	
2	11.8-13613-00	.REED, valve	2	
3	10V-13616-01	.STOPPER, reed valve	2	
4	97602-03108	.SCREW, pan head with washer	4	
5	39K-13621-00	GASKET, valve seat	1	
6	5X2-13565-00	JOINT, carburetor	1	
7	97301-06025	BOLT	4	
8	92901-06600	WASHER, plate	4	
9	90460-43053	CLAMP, hose	1	
10	90460-51059	CLAMP, hose	1	
11	39K-14401-00	AIR CLEANER CASE ASSY	1	
12	92506-06016	SCREW, pan head	3	
13	92906-06600	WASHER, plate	3	
14	39K-14453-00	JOINT, air cleaner 1	1	
15	90460-58124	CLAMP, hose	1	
16	39K-14451-00	ELEMENT, air cleaner	1	
17	39K-14458-00	GUIDE	1	
18	4V2-14468-01	PLATE, element fitting	1	
19	39K-14457-00	SEAL	1	
20	90504-03033	SPRING, compression	1	
21	39K-14402-00	CAP ASSY, air cleaner	1	UR competition yellow
	43K-14402-00	CAP ASSY, air cleaner	1	UR clean white
22	97702-40116	.SCREW, tapping	2	
23	5X5-1441L-00	.PANEL 1	1	
24	39K-14467-00	.SEAL	1	
25	39K-14452-00	.SEAL	1	
26	39K-21781-00	.EMBLEM 1	1	UR for U.S.A
	39K-21781-10	.EMBLEM 1	1	UR for Canada

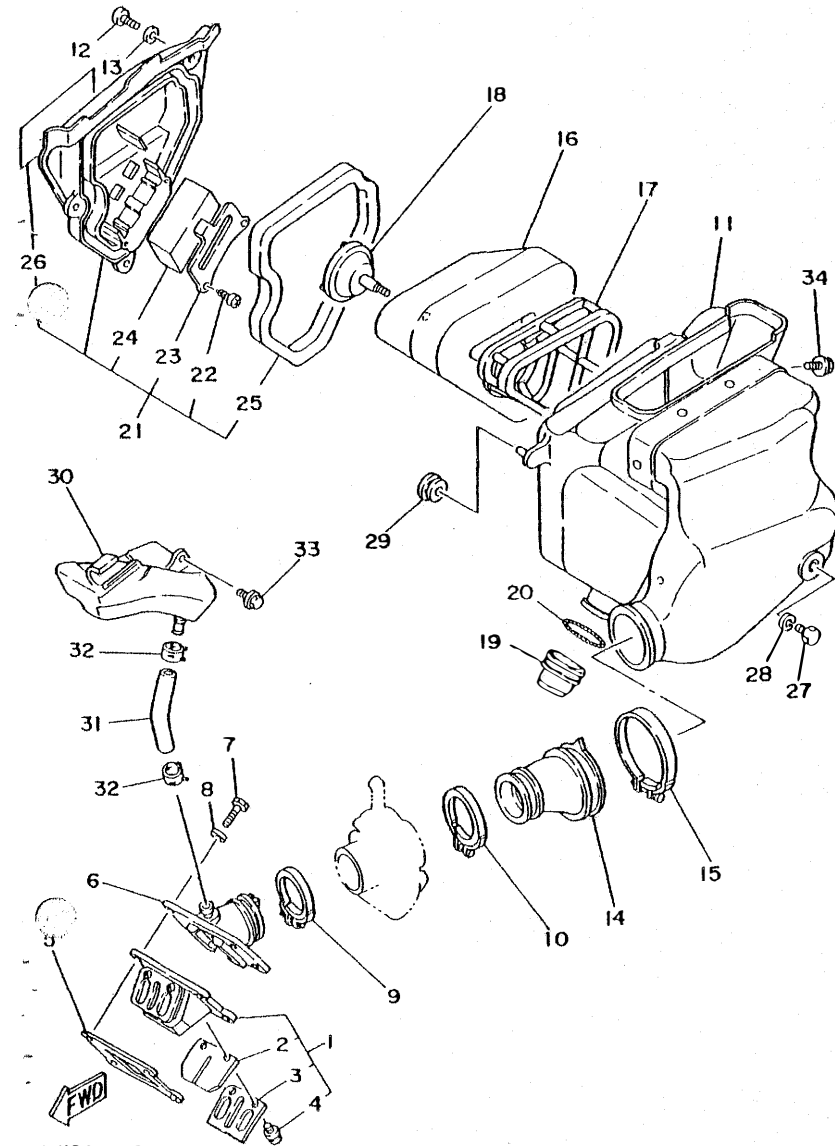

39K100-4050

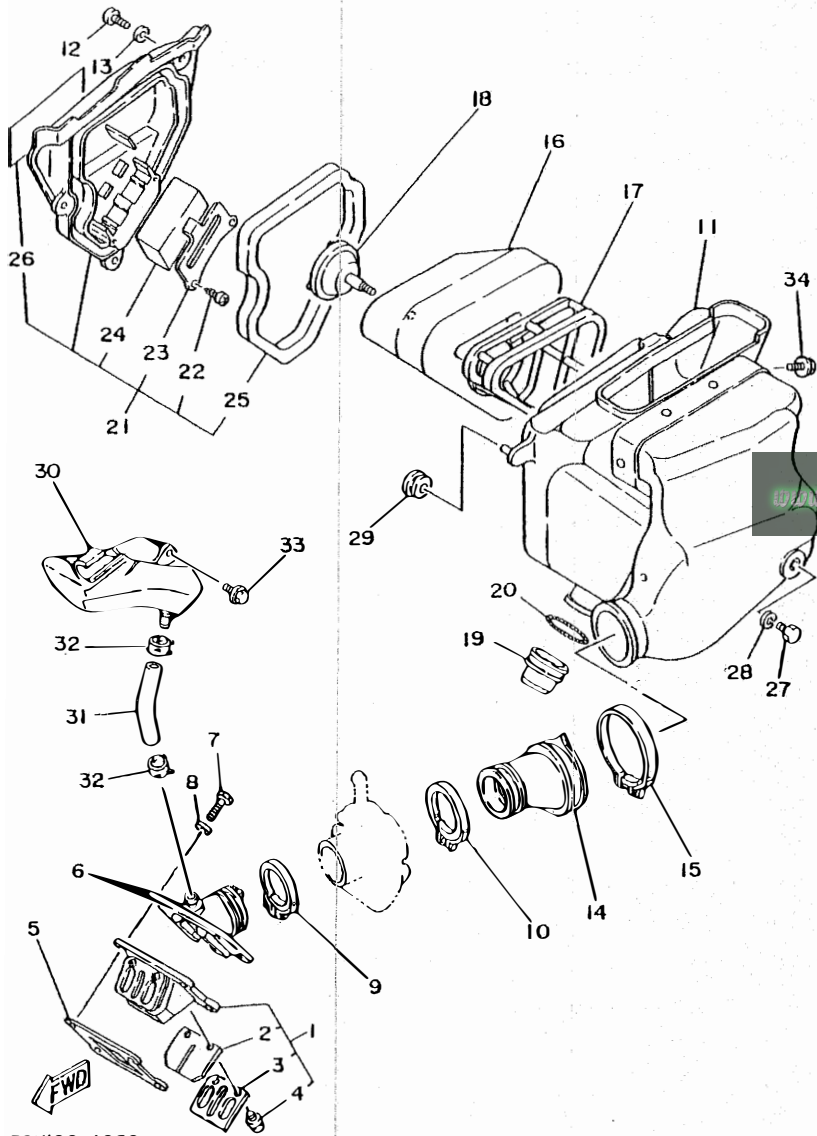

FIG. 5 INTAKE

REF. NO.	PART NO.	DESCRIPTION	Q'TY	REMARKS
27	97301-06012	BOLT	1	
28	92901-06100	WASHER, spring	1	
29	90480-13197	GROMMET	1	
30	22W-13581-00	CHAMBER, air	1	
31	90445-16673	HOSE	1	
32	90467-16063	CLIP	2	
33	90119-06043	BOLT, with washer	1	
34	90119-06085	BOLT, with washer	1	

39K100-4050

B7

FIG. 6 CARBURETOR

REF. NO.	PART NO.	DESCRIPTION	Q'TY	REMARKS
1	39K-14101-00	CARBURETOR ASSY 1	1	
2	304-14184-00	.GASKET, float chamber	1	
3	260-14142-35	.JET, pilot (# 35)	1	
4	23L-14107-25	.NEEDLE VALVE SET	1	
5	127-14186-00	.PIN, float	1	
6	22W-1490J-00	.NEEDLE SET	1	
7	93210-18288	.O-RING	1	
8	3R1-14115-00	.PLUG, screw	1	
9	3R1-14141-44	.NOZZLE, main	1	
10	137-14143-48	.JET, main (#240)	1	STD
	137-14143-46	.JET, main (#230)	1	AP
	137-14143-50	.JET, main (#250)	1	AP
11	314-14185-00	.FLOAT	1	
12	10W-14103-00	.THROTTLE SCREW SET	1	
13	183-14196-00	.PIPE	2	
14	98511-04016	.SCREW, pan head	4	
15	92902-04100	.WASHER, spring	4	
16	22W-14106-00	.CABLE ADJUST SCREW SET	1	
17	3X3-14169-00	.CAP	1	
18	3R1-14153-00	.WASHER, main jet	1	
19	2X6-14112-20	.VALVE, throttle 1	1	
20	248-14131-00	.SPRING, throttle valve	1	
21	2A6-14126-00	.GASKET	1	
22	2A6-14158-00	.TOP, mixing chamber	1	
23	4U5-14171-00	.PLUNGER, starter	1	
24	10W-14104-00	.AIR SCREW SET	1	

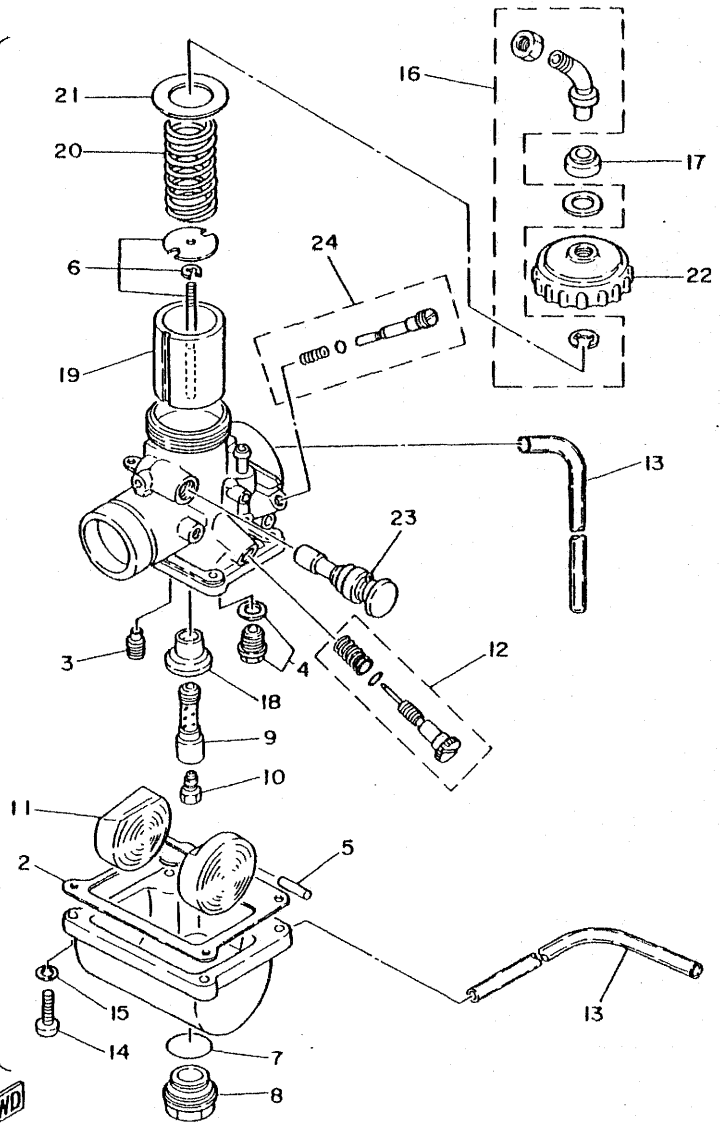

22W100-3070

www.legends-yamaha-enduros.com

FIG. 7 EXHAUST

REF. NO.	PART NO.	DESCRIPTION	Q'TY	REMARKS
1	39K-14610-00	EXHAUST PIPE ASSY 1	1	
2	39K-14718-00	PROTECTOR, muffler 1	1	
3	98906-06008	SCREW, bind	2	
4	90202-06010	WASHER, plate	2	
5	22W-14613-00	GASKET, exhaust pipe	1	
6	90507-20030	SPRING, tension	2	
7	565-14771-00	STAY, muffler 1	1	
8	97301-06016	BOLT	2	
9	92901-06100	WASHER, spring	2	
10	92901-06600	WASHER, plate	2	
11	39K-14753-00	SILENCER, exhaust	1	

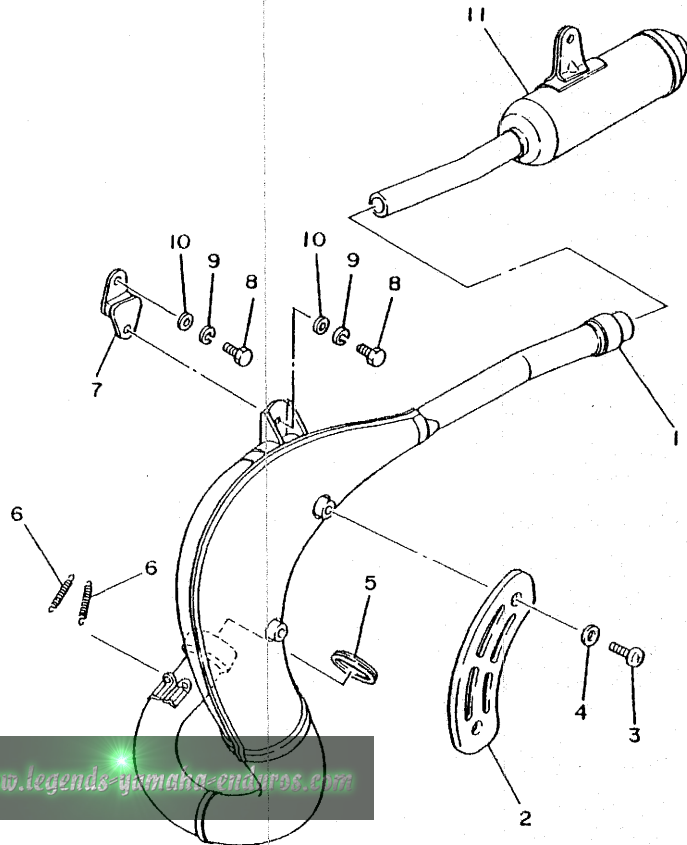

www.legends-yamaha-ent.com



22W100-3081

B9

FIG. 8 CRANKCASE

REF. NO.	PART NO.	DESCRIPTION	Q'TY	REMARKS
1	39K-15111-00	CRANKCASE 1	1	
2	92501-06045	SCREW, pan head	6	
3	92501-06035	SCREW, pan head	3	
4	353-13115-01	CONNECTOR, suction pipe	1	
5	90445-08376	HOSE	1	
6	91830-22016	PIN, dowel	2	
7	39K-15121-00	CRANKCASE 2	1	
8	90338-07011	PLUG	1	
9	5X2-15113-00	PLATE	1	
10	92501-06012	SCREW, pan head	1	
11	90340-12095	PLUG, straight screw	1	
12	90430-12038	GASKET	1	

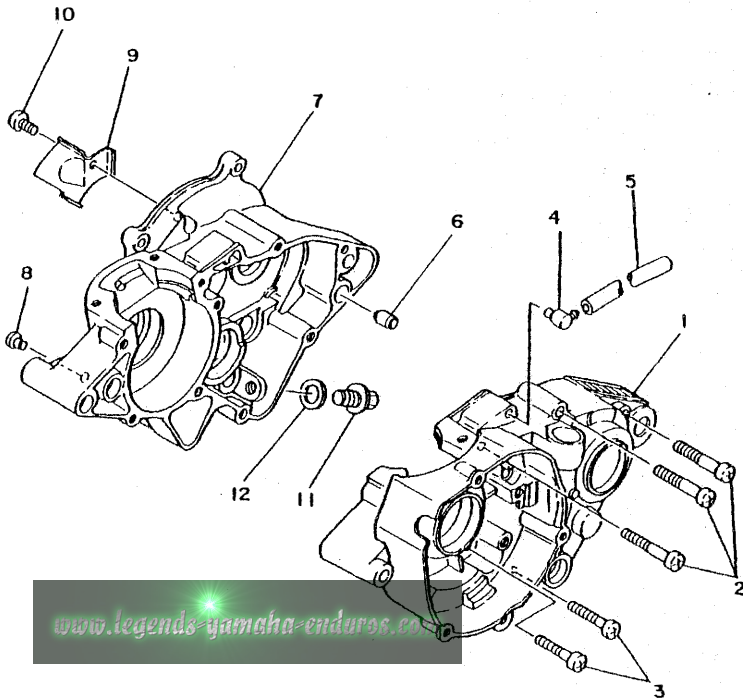

[www.legends-yamaha-enduro.com](http://www.legends-yamaha-enduro.com)



22W100-3090

**B10**

FIG. 9 CRANKCASE COVER 1

REF. NO.	PART NO.	DESCRIPTION	Q'TY	REMARKS
1	4V0-15411-00	COVER, crankcase 1	1	
2	22W-15451-00	GASKET, crankcase cover 1	1	
3	92506-06030	SCREW, pan head	3	
4	22W-15421-00	COVER, crankcase 2	1	
5	5X2-15462-00	GASKET, crankcase cover 3	1	
6	91830-21014	PIN, dowel	2	
7	92506-06025	SCREW, pan head	6	
8	92506-06040	SCREW, pan head	1	
9	4J2-15363-00	PLUG, oil	1	
10	93210-14104	O-RING	1	
11	92506-06008	SCREW, pan head	1	
12	90430-06016	GASKET	1	

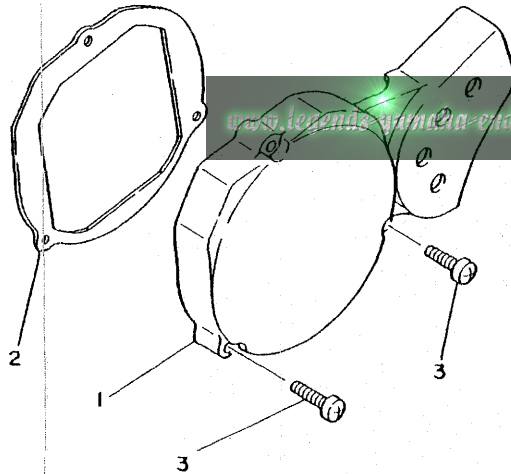
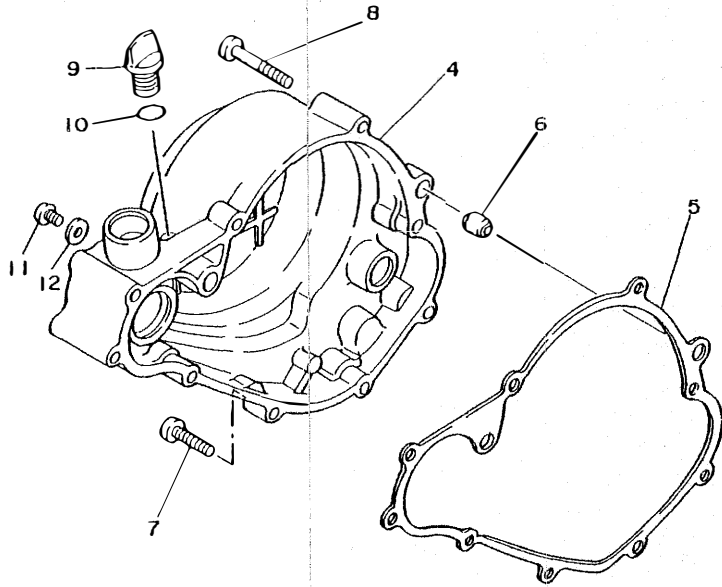

22W100-3101

**B11**







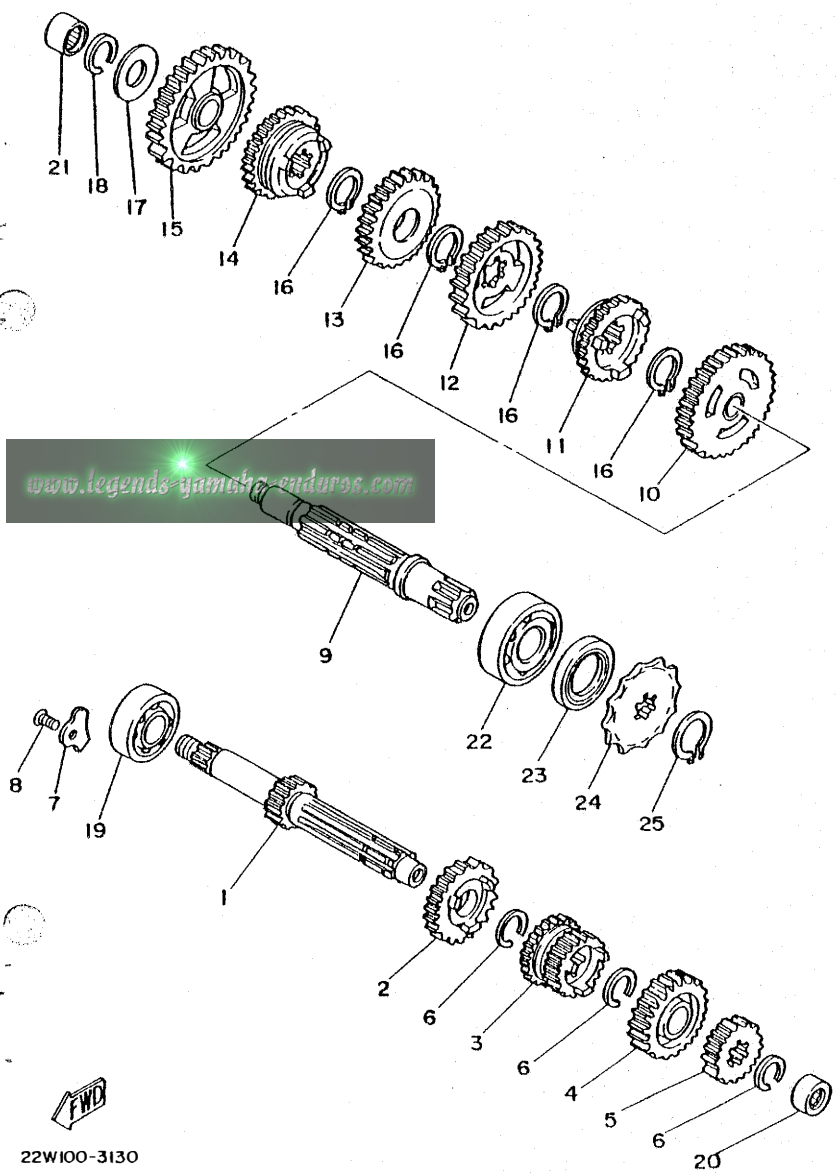

22W100-3130

FIG. 12 TRANSMISSION

REF. NO.	PART NO.	DESCRIPTION	Q'TY	REMARKS
1	4V0-17411-01	AXLE, main	1	
2	39K-17151-00	GEAR, 5th pinion (22T)	1	
3	39K-17131-00	GEAR, 3rd pinion (16T/19T)	1	
4	39K-17161-00	GEAR, 6th pinion (23T)	1	
5	4V0-17121-00	GEAR, 2nd pinion (16T)	1	
6	93440-16089	CIRCLIP	3	
7	3R4-15383-01	PLATE, bearing cover	2	
8	92701-06012	SCREW, flat head	2	
9	22W-17421-00	AXLE, drive	1	
10	39K-17221-00	GEAR, 2nd wheel (33T)	1	
11	39K-17261-00	GEAR, 6th wheel (26T)	1	
12	4V0-17231-00	GEAR, 3rd wheel (31T)	1	
13	39K-17241-00	GEAR, 4th wheel (22T)	1	
14	39K-17251-00	GEAR, 5th wheel (27T)	1	
15	4V0-17211-00	GEAR, 1st wheel (36T)	1	
16	93410-20038	CIRCLIP	4	
17	164-17427-00-06	SHIM 1 (0.6T)	1	
18	93440-15012	CIRCLIP	1	
19	93306-20333	BEARING	1	
20	93317-11245	BEARING, cylindrical	1	
21	93315-31502	BEARING, cylindrical	1	
22	93306-20401	BEARING (B6204)	1	
23	93102-20143	OIL SEAL	1	
24	174-17461-40	SPROCKET, drive (14T)	1	
	174-17461-20	SPROCKET, drive (12T)	1	AP
	174-17461-30	SPROCKET, drive (13T)	1	AP
	174-17461-50	SPROCKET, drive (15T)	1	AP
25	93410-18062	CIRCLIP	1	

**B14**

FIG. 13 SHIFT CAM. FORK

REF. NO.	PART NO.	DESCRIPTION	Q'TY	REMARKS
1	22W-18540-00	SHIFT CAM ASSY	1	
2	22W-18140-00	STOPPER LEVER ASSY	1	
3	90508-26462	SPRING, torsion	1	
4	1W1-18177-00	BOLT, stopper	1	
5	4V0-18511-00	FORK, shift 1	1	
6	39K-18512-00	FORK, shift 2	1	
7	4V0-18513-00	FORK, shift 3	1	
8	90250-06013	PIN, straight	3	
9	5X5-18531-01	BAR, shift fork guide 1	1	
10	5X5-18535-01	BAR, shift fork guide 2	1	

www.legends-yamaha-enduros.com

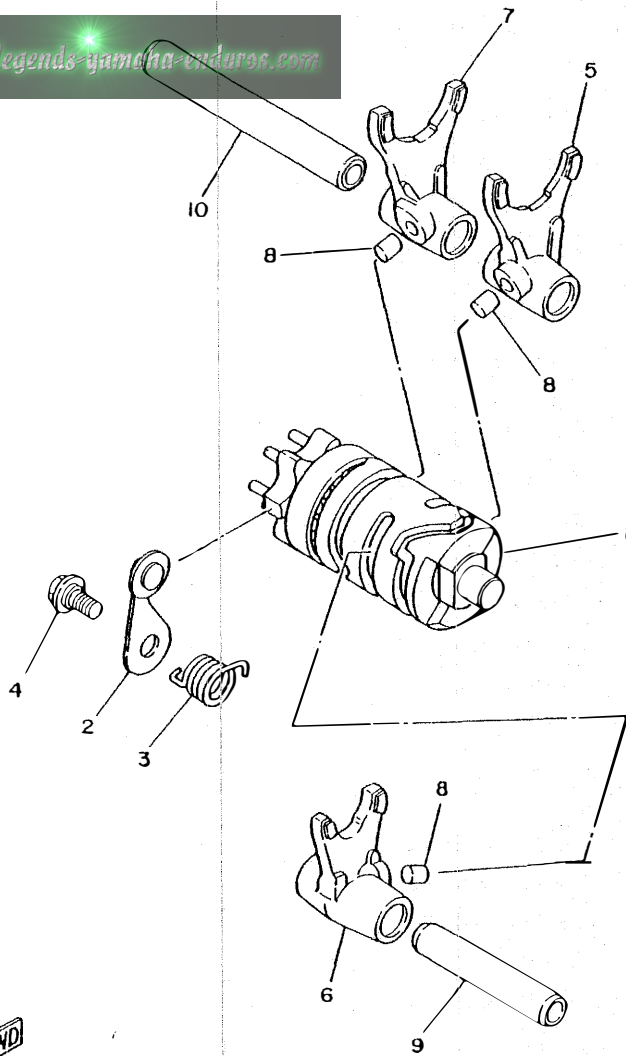

22W100-3140

**B15**

FIG. 14 SHIFT SHAFT

REF. NO.	PART NO.	DESCRIPTION	Q'TY	REMARKS
1	22W-18101-00	SHIFT SHAFT ASSY	1	
2	93430-10016	CIRCLIP	1	
3	90508-32465	SPRING, torsion	1	
4	93608-30128	PIN, dowel	1	
5	93109-12012	OIL SEAL	1	
6	22W-18110-00	SHIFT PEDAL ASSY	1	
7	97321-06020	BOLT	1	

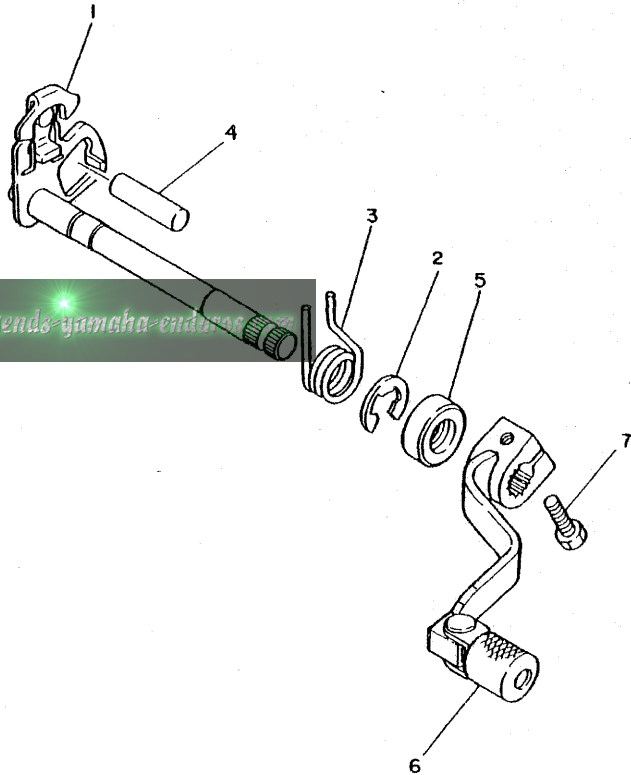

www.legends-yamaha-enduro.com



22W100-3150

FIG. 15 FRAME

REF. NO.	PART NO.	DESCRIPTION	Q'TY	REMARKS
1	39K-21110-00-FH	FRAME COMP.	1	UR fire red
	39K-21110-00-33	FRAME COMP.	1	UR yamaha black
2	95811-08125	BOLT, flange	1	
3	95811-08135	BOLT, flange	1	
4	90185-08113	NUT, self-locking	2	
5	22W-22178-01	TENSIONER	1	
6	4V4-22184-00	BUSH	1	
7	90201-067A0	WASHER, plate	1	
8	97301-06016	BOLT	1	
9	92902-06700	WASHER	1	
10	39K-2174F-00	GUARD, radiator	1	
11	95021-08012	BOLT, flange	2	
12	39K-28100-00	TOOL KIT	1	

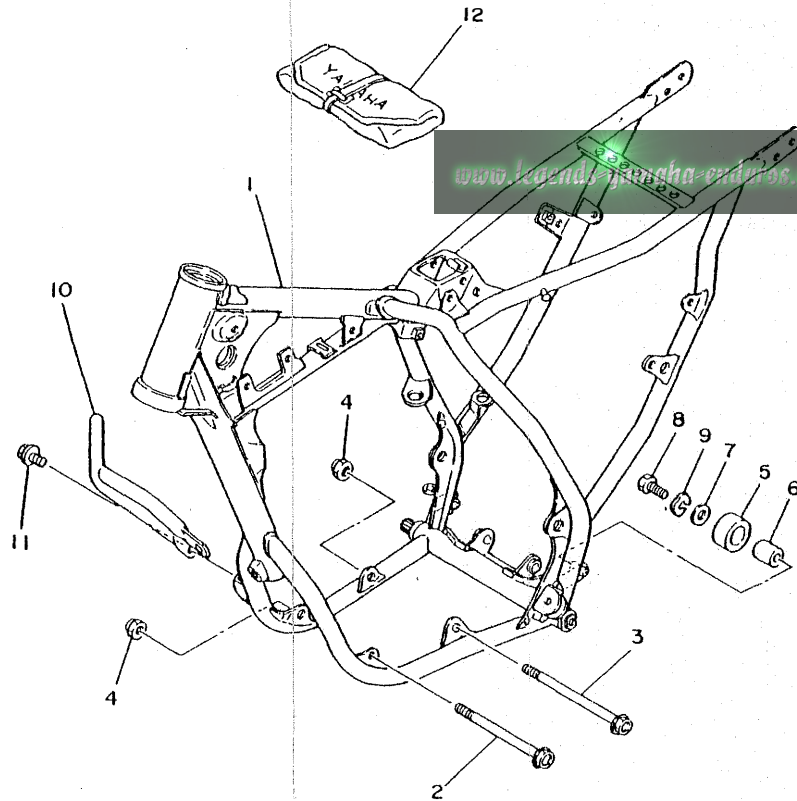

22W100-3161

C3

FIG. 16 FENDER

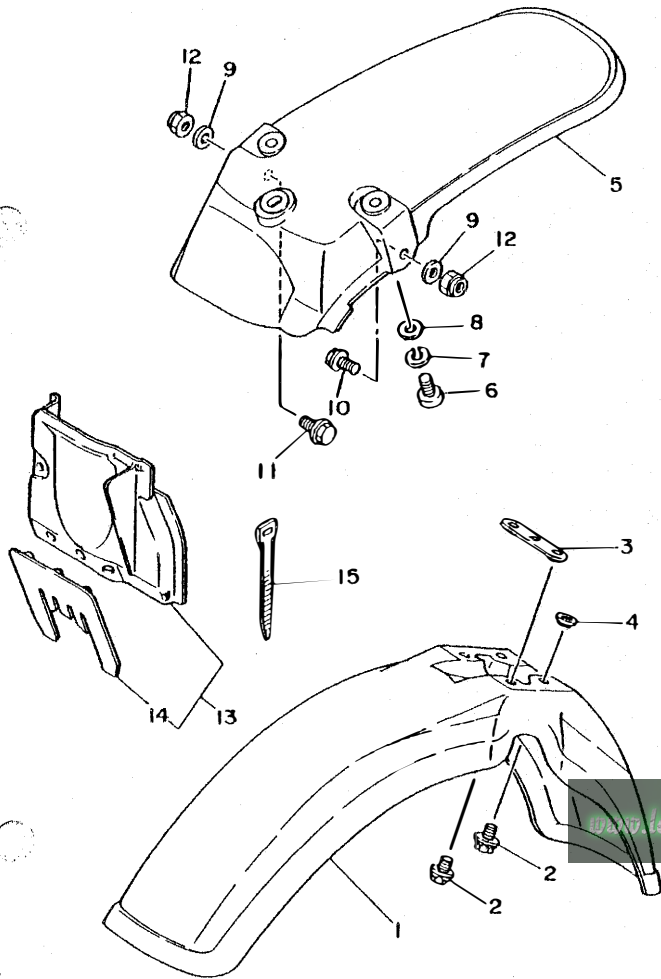

REF. NO.	PART NO.	DESCRIPTION	Q'TY	REMARKS
1	5X2-21511-00	FENDER, front	1	UR competition yellow
	5X2-21511-10	FENDER, front	1	UR clean white
2	90119-06063	BOLT, with washer	4	
3	22W-21523-00	PLATE 1	1	
4	90209-06187	WASHER	2	
5	22W-21611-00	FENDER, rear	1	UR competition yellow
	22W-21611-10	FENDER, rear	1	UR clean white
6	92502-06016	SCREW, pan head	3	
7	92902-06100	WASHER, spring	3	
8	90201-06557	WASHER, plate	3	
9	90201-08730	WASHER, plate	2	
10	95801-08025	BOLT, flange	1	
11	95801-08020	BOLT, flange	1	
12	90185-08113	NUT, self-locking	2	
13	39K-21620-00	MUD GUARD COMP.	1	
14	4V0-21621-00	FLAP	1	
15	437-83936-00	BAND, switch cord	1	



22WI00-3171

FIG. 17 SIDE COVER

REF. NO.	PART NO.	DESCRIPTION	Q'TY	REMARKS
1	39K-21711-00	COVER, side 1	1	UR competition yellow
	39K-21711-10	COVER, side 1	1	UR clean white
2	22W-24181-00	DAMPER, locating 1	2	
3	39K-21781-00	EMBLEM 1	1	UR for U.S.A
	39K-21781-10	EMBLEM 1	1	UR for Canada
4	3R1-21782-00	EMBLEM 2	1	
5	92501-06014	SCREW, pan head	2	
6	92901-06100	WASHER, spring	2	
7	90201-06571	WASHER, plate	2	
8	39K-21721-00	COVER, side 2	1	UR competition yellow
	39K-21721-10	COVER, side 2	1	UR clean white
9	3R1-21782-00	EMBLEM 2	1	
10	92501-06014	SCREW, pan head	2	
11	92901-06100	WASHER, spring	2	
12	90201-06571	WASHER, plate	2	
13	39K-21741-00	COVER, side 4	1	UR competition yellow
	39K-21741-10	COVER, side 4	1	UR clean white
14	22W-21746-00	DAMPER	1	*
15	22W-21791-00	NUT	3	
16	90159-05101	SCREW, with washer	2	
17	90159-05100	SCREW, with washer	1	
18	39K-2172A-00	PANEL 1	1	
19	90480-12053	GROMMET	1	

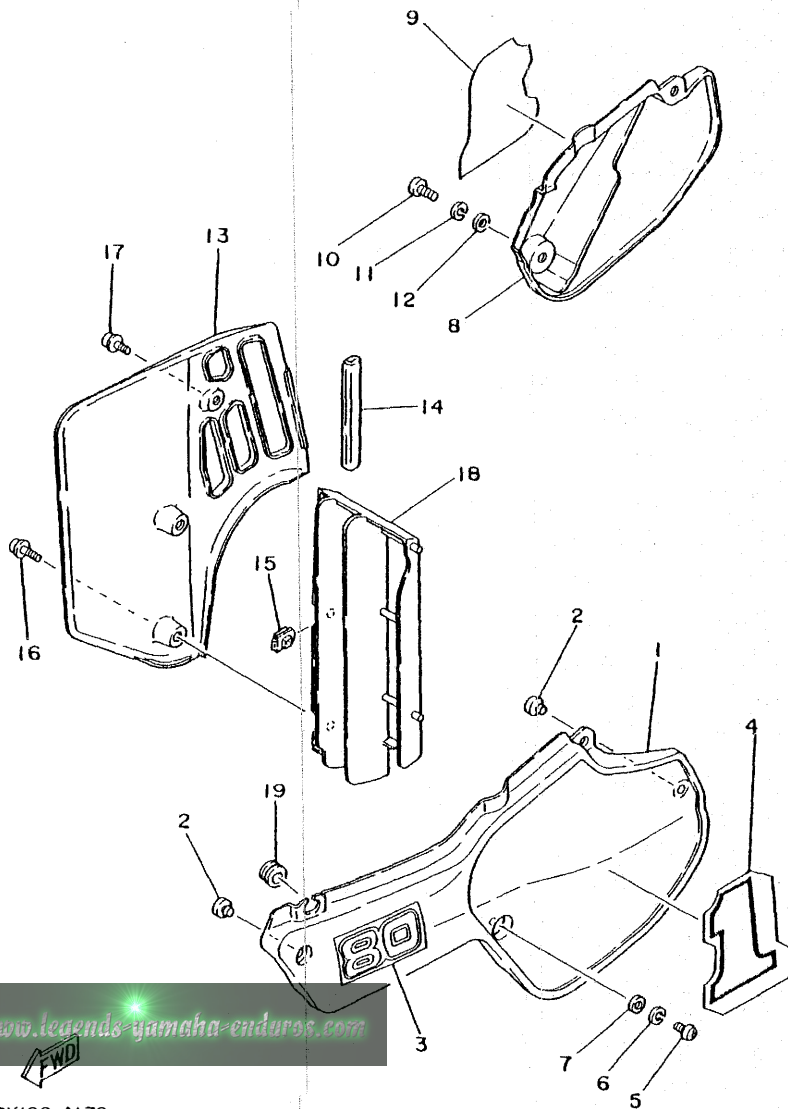

www.legends-yamaha-enduros.com



39K100-4170

\* SUB TO RED. P/NO REM. SAME  
P/NEWS - M/C 89002  
14-1-89.

C5

FIG. 18 REAR ARM

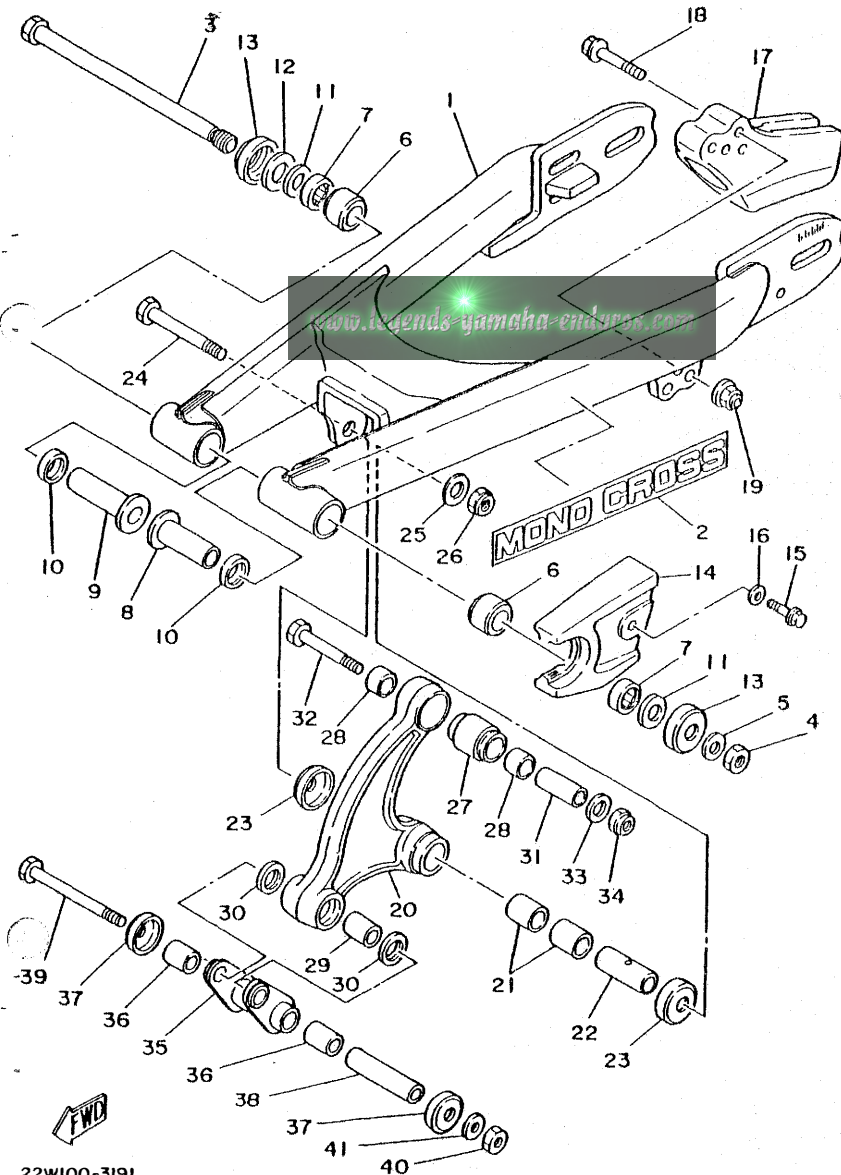

REF. NO.	PART NO.	DESCRIPTION	Q'TY	REMARKS
1	39K-22110-00-35	REAR ARM COMP.	1	silver
2	5X1-2218A-00	EMBLEM, rear arm	2	
3	4V1-22141-00	SHAFT, pivot	1	
4	90185-12119	NUT, self-locking	1	
5	90201-12469	WASHER, plate	1	
6	90385-17042	BUSH	2	
7	93317-21746	BEARING, cylindrical	2	
8	90387-127J8	COLLAR	1	
9	90387-127J7	COLLAR	1	
10	93109-17048	OIL SEAL	2	
11	90201-174H1	WASHER, plate	2	
12	401-22127-00	SHIM	1	
13	401-22128-01	SEAL, guard	2	
14	39K-22151-00	SEAL, guard	1	
15	95801-06025	BOLT, flange	1	
16	90201-06067	WASHER, plate	1	
17	39K-22199-00	SUPPORT, chain	1	
18	95821-08040	BOLT, flange	2	
19	90185-08113	NUT, self-locking	2	
20	39K-2217A-00	ARM, relay	1	
21	90384-18190	BUSH, bimetal formed	2	
22	90380-12094	BUSH, solid	1	
23	5X6-22129-00	COVER, thrust 2	2	
24	90109-10690	BOLT	1	
25	90201-100E9	WASHER, plate	1	
26	90185-10110	NUT, self-locking	1	
27	22W-22124-00	BUSH 2	1	
28	90380-16109	BUSH, solid	2	

22W100-3191

C6

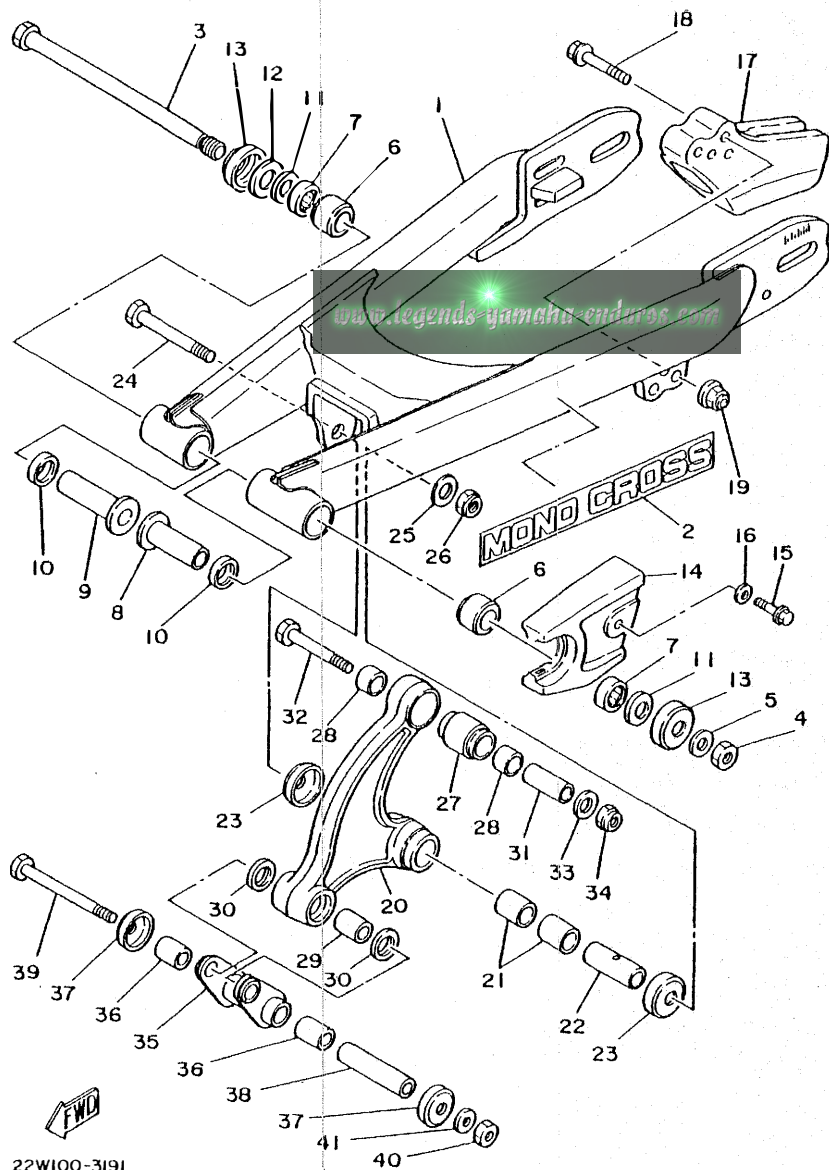

22W100-3191

FIG. 18 REAR ARM

REF. NO.	PART NO.	DESCRIPTION	Q'TY	REMARKS
29	90383-16023	BUSH, formed	1	
30	93109-16035	OIL SEAL	2	
31	90387-10660	COLLAR	1	
32	90109-10689	BOLT	1	
33	92901-10600	WASHER, plate	1	
34	90185-10110	NUT, self-locking	1	
35	22W-2217F-00	ROD, connecting 1	1	
36	90383-16023	BUSH, formed	2	
37	22W-22129-00	COVER, thrust 2	2	
38	90387-10569	COLLAR	1	
39	90109-10688	BOLT	1	
40	90185-10110	NUT, self-locking	1	
41	92901-10600	WASHER, plate	1	



FIG. 19 REAR SUSPENSION

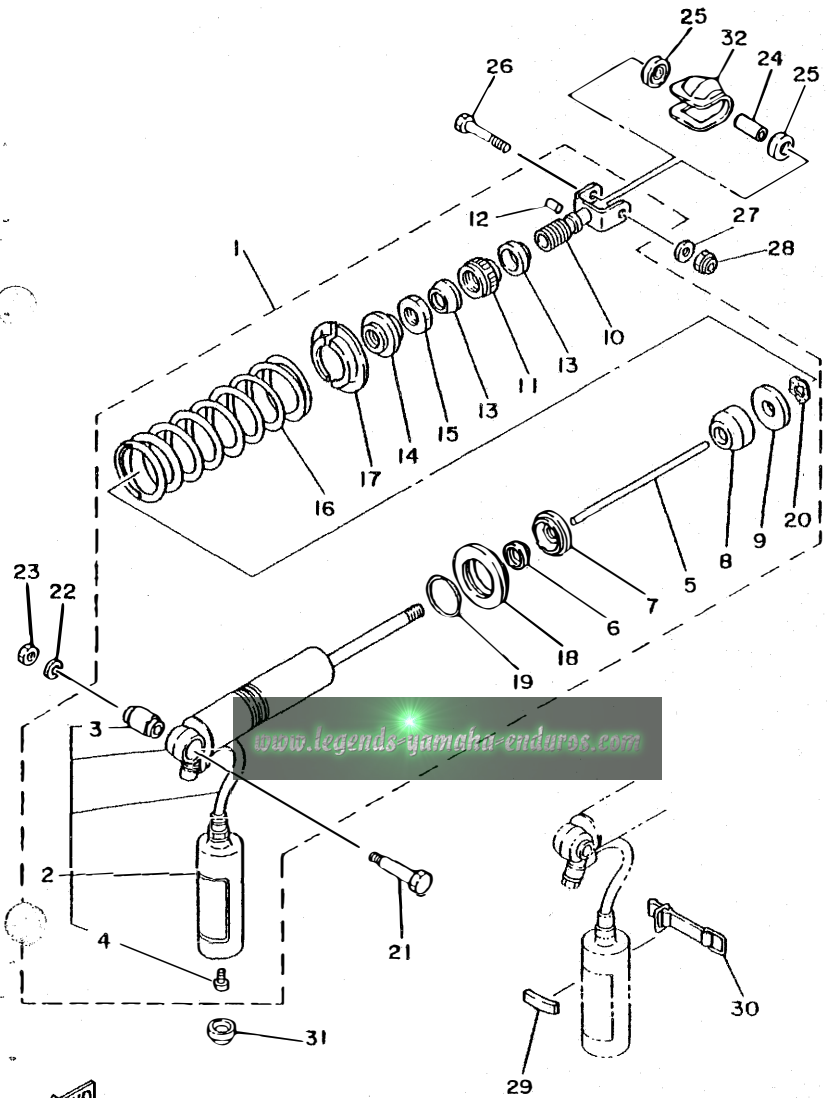

REF. NO.	PART NO.	DESCRIPTION	Q'TY	REMARKS
1	39K-22210-00-26	SHOCK ABSORBER ASSY, rear	1	UR competition yellow
	39K-22210-00-6W	SHOCK ABSORBER ASSY, rear	1	UR native red
2	39K-22401-00	.DAMPER SUB ASSY	1	
3	2X6-22216-00	.BUSH, rear shock absorber	1	
4	98501-04005	.SCREW, pan head	1	
5	22W-22489-00	.ROD, push	1	
6	29L-22475-00	.SEAL, dust	1	
7	39K-22472-00	.CAP, case	1	
8	5X2-22493-00	.BUMP, stop	1	
9	5X2-22228-00	.SUPPORT, bump stop	1	
10	22W-22409-00	.UPPER BRACKET SUB ASSY	1	
11	3R4-22497-00	.NUT, adjusting	1	
12	93604-26132	.PIN, dowel	1	
13	3R4-22221-01	.COVER	2	
14	3R4-22213-00	.SEAT, spring upper	1	
15	90170-20213	.NUT	1	
16	22W-22212-20-26	.SPRING	1	UR competition yellow
	22W-22212-20-6W	.SPRING	1	UR native red
17	22W-22214-00	.GUIDE, spring 1	2	
18	22W-22223-00	.SEAT, spring lower	1	
19	93440-42101	.CIRCLIP	1	
20	90206-12082	.WASHER, wave	1	
21	90109-10729	BOLT	1	
22	92901-10600	WASHER, plate	1	
23	90185-10110	NUT, self-locking	1	
24	90387-10660	COLLAR	1	
25	22W-22129-00	COVER, thrust 2	2	
26	90109-10689	BOLT	1	

FWD  
39K100-4190

FIG. 19 REAR SUSPENSION

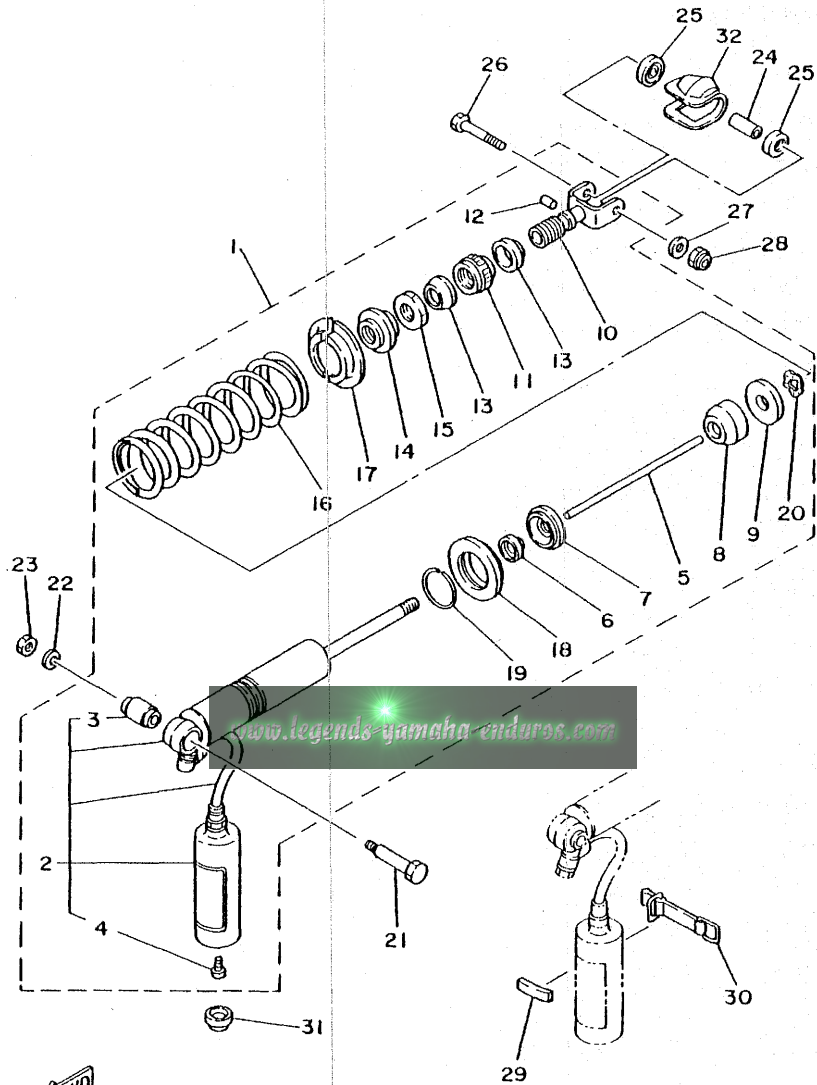

REF. NO.	PART NO.	DESCRIPTION	Q'TY	REMARKS
27	92901-10600	WASHER, plate	1	
28	90185-10110	NUT, self-locking	1	
29	24X-22261-00	DAMPER, sub tank	1	
30	24X-22262-00	HOLDER, sub tank	1	
31	90480-17359	GROMMET	1	
32	22W-22189-00	BOOT, rubber	1	



39K100-4190

C9

FIG. 20 STEERING

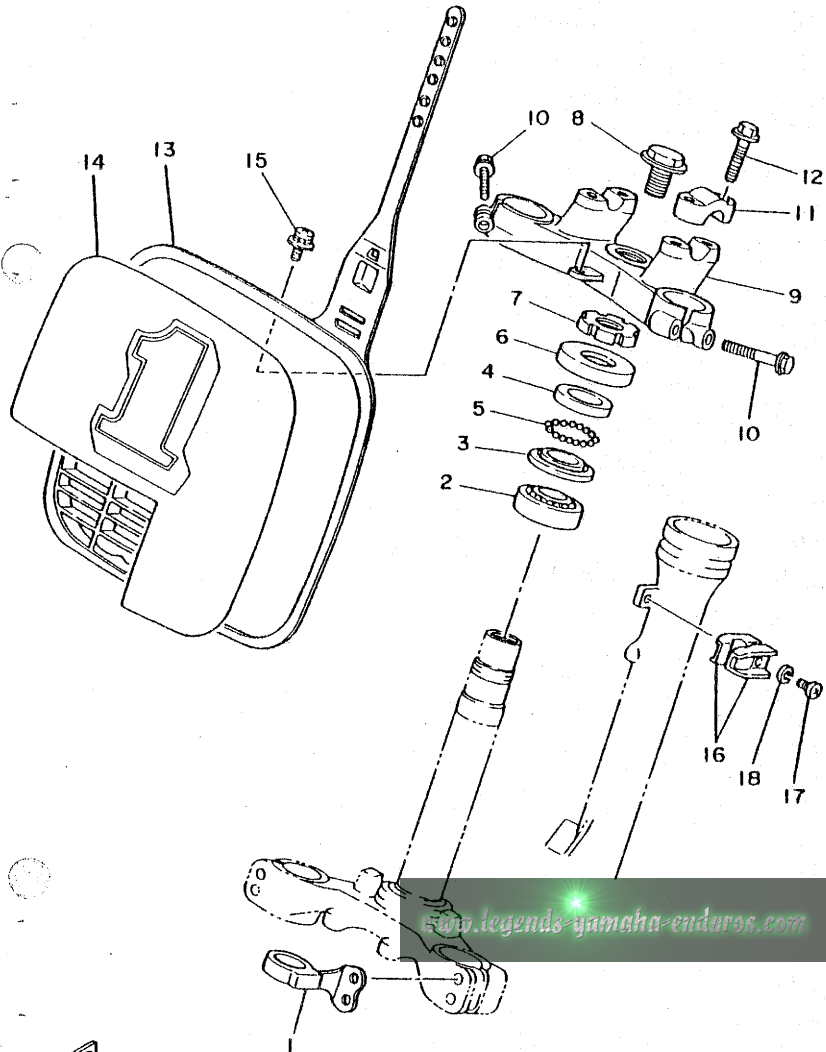

REF. NO.	PART NO.	DESCRIPTION	Q'TY	REMARKS
1	3R4-23389-00	GUIDE, cable	1	
2	93332-00059	BEARING	1	
3	122-23411-00	RACE, ball 1	1	
4	122-23412-00	RACE, ball 2	1	
5	93503-16010	BALL	22	
6	122-23416-00	COVER, ball race 2	1	
7	90179-25033	NUT	1	
8	90105-14137	BOLT, washer based	1	
9	22W-23435-00-98	CROWN, handle	1	low gloss black
10	95801-08035	BOLT, flange	2	
11	1E6-23441-00	HOLDER, handle upper	2	
12	95821-08030	BOLT, flange	4	
13	22W-23485-01	PLATE, number	1	UR competition yellow
	22W-23485-11	PLATE, number	1	UR clean white
14	22W-21785-00	EMBLEM 5	1	
15	90159-06060	SCREW, with washer	1	
16	90462-14055	CLAMP	2	
17	92501-06012	SCREW, pan head	1	
18	92901-06100	WASHER, spring	1	



FIG. 21 FRONT FORK

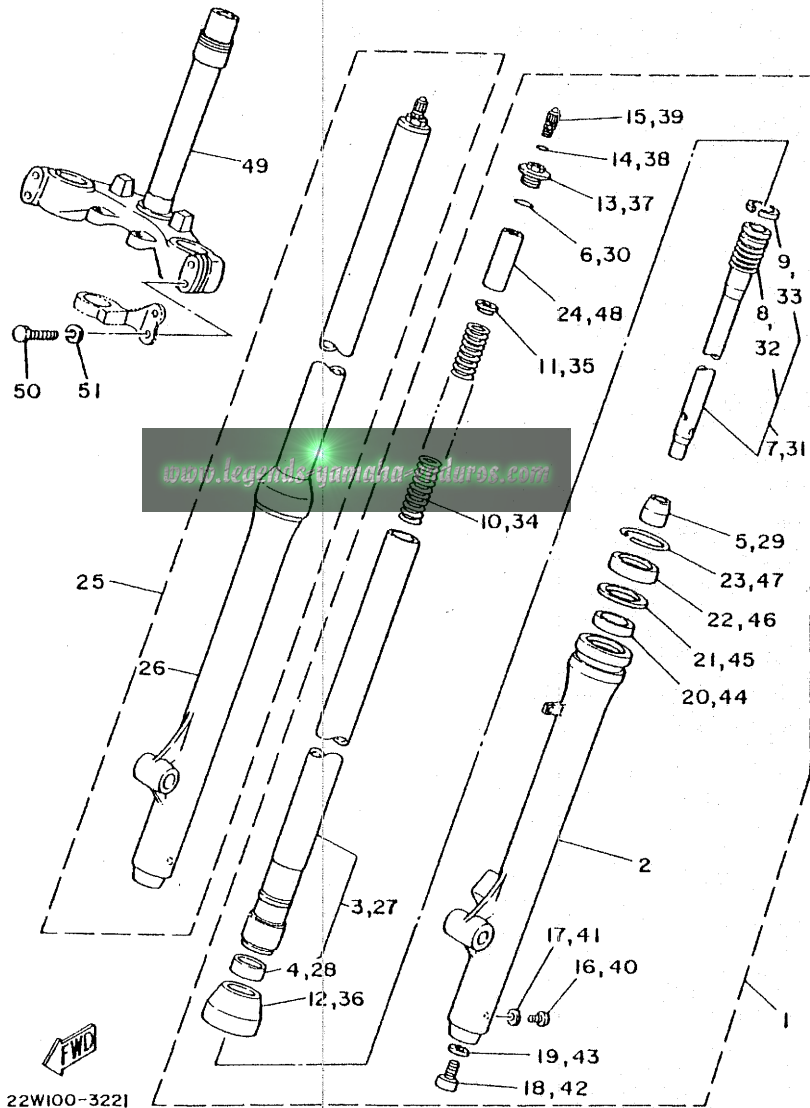

22W100-3221

REF. NO.	PART NO.	DESCRIPTION	Q'TY	REMARKS
1	39K-23102-LO	FRONT FORK ASSY (L.H)	1	
2	39K-23126-LO	.TUBE, outer 1	1	
3	22W-23110-LO	.INNER TUBE COMP.1	1	
4	22W-2312K-00	..PISTON, front fork	1	
5	3R8-23173-LO	.SPINDLE, taper	1	
6	3J2-23114-00	.O-RING	1	
7	39K-23170-LO	.CYLINDER COMP., front fork	1	
8	509-23151-LO	..SPRING, rebound	1	
9	22W-23157-LO	..RING, piston	1	
10	39K-23141-00	.SPRING, front fork	1	
11	583-23142-00	.SEAT, spring upper	1	
12	22W-23144-LO	.SEAL, dust	1	
13	22W-23111-LO	.BOLT, cap	1	
14	3J2-23147-00	.O-RING	1	
15	23X-23190-LO	.AIR VALVE COMP.	1	
16	122-23119-01	.PLUG, drain	1	
17	122-23129-00	.GASKET, drain plug	1	
18	278-23181-50	.BOLT, hexagon socket head	1	
19	509-23158-LO	.GASKET	1	
20	22W-23125-LO	.METAL, slide 1	1	
21	22W-23146-LO	.WASHER, oil seal	1	
22	22W-23145-LO	.OIL SEAL	1	
23	22W-23153-LO	.RING, snap	1	
24	15R-23118-00	.SPACER	1	
25	39K-23103-LO	FRONT FORK ASSY (R.H)	1	
26	39K-23136-LO	.TUBE, outer 2	1	
27	22W-23110-LO	.INNER TUBE COMP.1	1	
28	22W-2312K-00	..PISTON, front fork	1	

C11

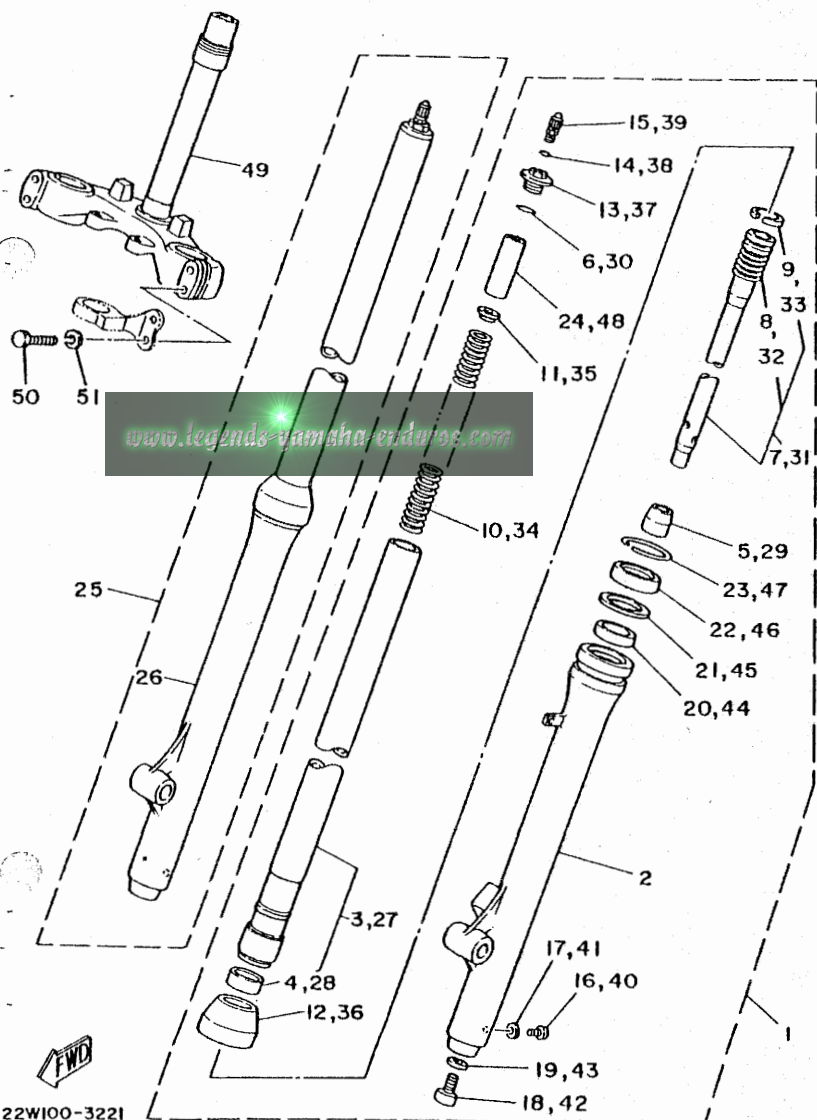

FIG. 21 FRONT FORK

REF. NO.	PART NO.	DESCRIPTION	Q'TY	REMARKS
29	3R8-23173-L0	.SPINDLE, taper	1	
30	3J2-23114-00	.O-RING	1	
31	39K-23170-L0	.CYLINDER COMP., front fork	1	
32	509-23151-L0	.SPRING, rebound	1	
33	22W-23157-L0	.RING, piston	1	
34	39K-23141-00	.SPRING, front fork	1	
35	583-23142-00	.SEAT, spring upper	1	
36	22W-23144-L0	.SEAL, dust	1	
37	22W-23111-L0	.BOLT, cap	1	
38	3J2-23147-00	.O-RING	1	
39	23X-23190-L0	.AIR VALVE COMP.	1	
40	122-23119-01	.PLUG, drain	1	
41	122-23129-00	.GASKET, drain plug	1	
42	278-23181-50	.BOLT, hexagon socket head	1	
43	509-23158-L0	.GASKET	1	
44	22W-23125-L0	.METAL, slide 1	1	
45	22W-23146-L0	.WASHER, oil seal	1	
46	22W-23145-L0	.OIL SEAL	1	
47	22W-23153-L0	.RING, snap	1	
48	15R-23118-00	.SPACER	1	
49	39K-23340-L0-39	UNDER BRACKET COMP.	1	
50	97321-08035	BOLT	4	
51	92901-08100	WASHER, spring	4	

FWD  
22W100-3221

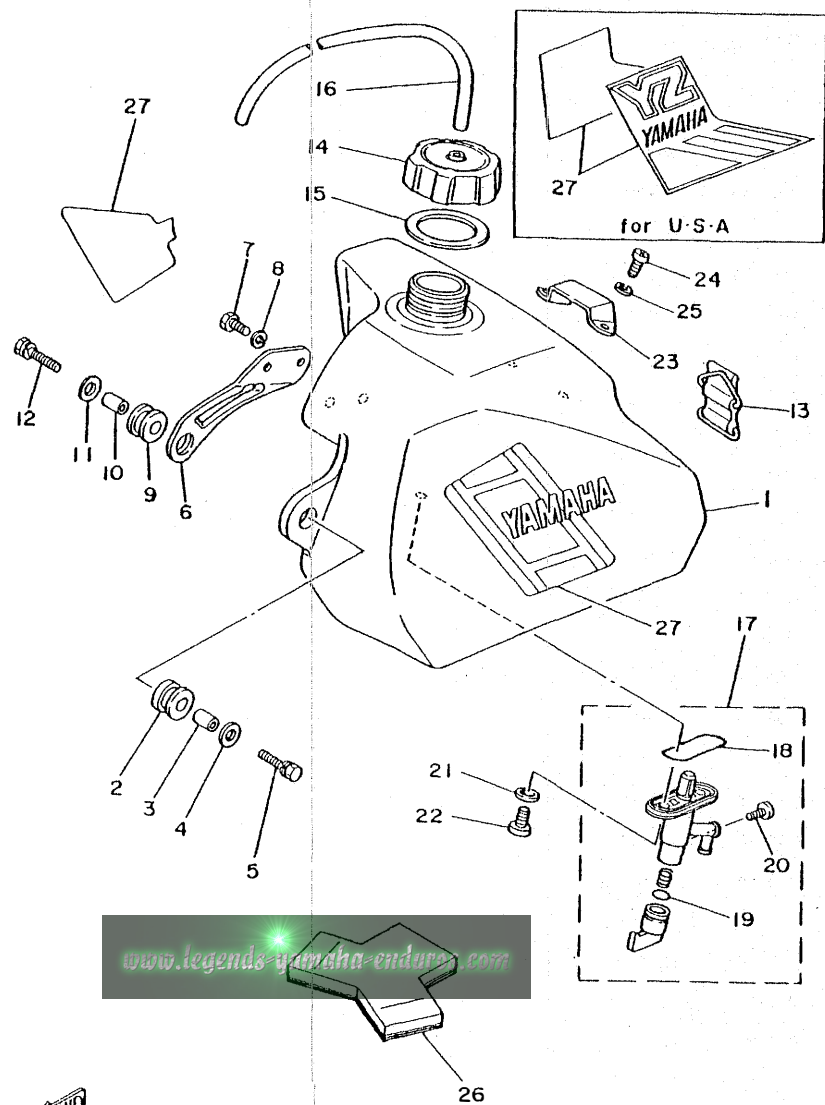
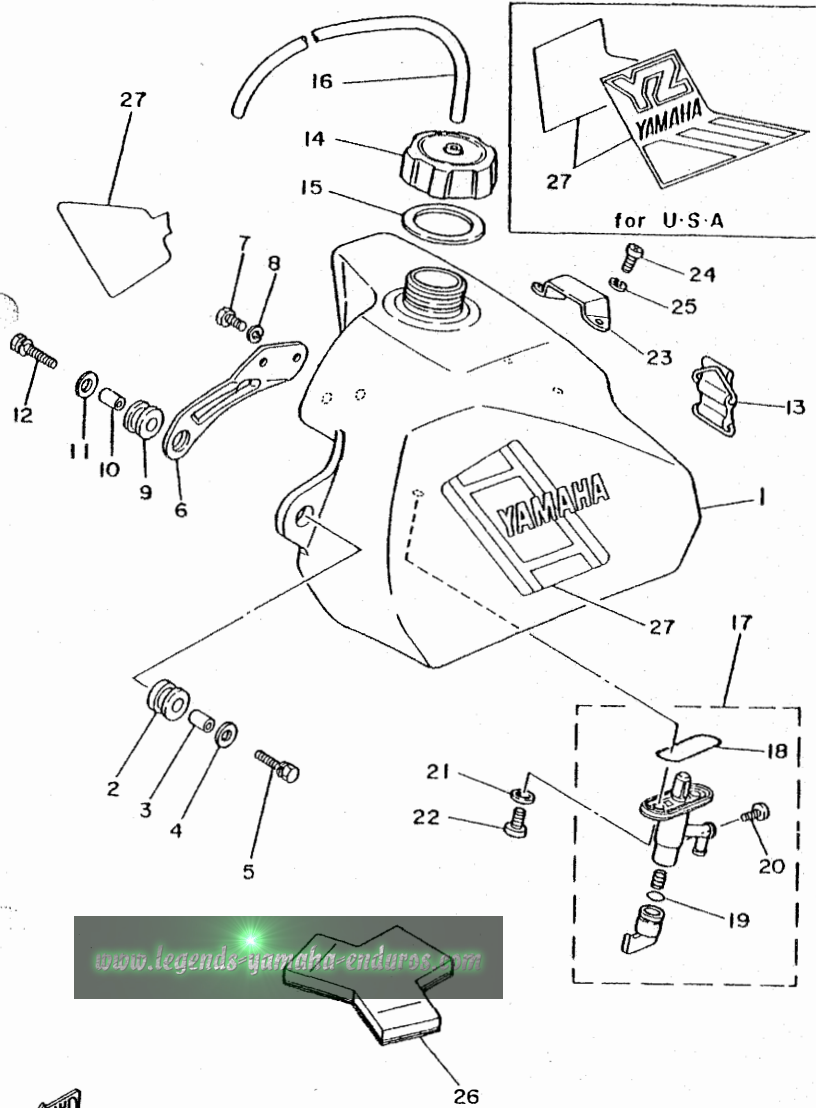

FIG. 22 FUEL TANK

REF. NO.	PART NO.	DESCRIPTION	Q'TY	REMARKS
1	22W-24110-00	FUEL TANK COMP.	1	UR competition yellow
	22W-24110-10	FUEL TANK COMP.	1	UR clean white
2	90480-18290	GROMMET	1	
3	90387-07598	COLLAR	1	
4	90201-06072	WASHER, plate	1	
5	90119-06073	BOLT, with washer	1	
6	22W-24158-00	STAY, fuel tank 2	1	
7	97301-06012	BOLT	2	
8	92901-06100	WASHER, spring	2	
9	90480-18290	GROMMET	1	
10	90387-07598	COLLAR	1	
11	90201-06072	WASHER, plate	1	
12	90119-06073	BOLT, with washer	1	
13	3R3-24173-00	BAND, tank fitting 1	1	
14	5X7-24611-01	BODY, cap	1	
15	5X7-24612-00	GASKET, cap	1	
16	90445-09304	HOSE	1	
17	2K5-24500-00	FUEL COCK ASSY 1	1	
18	214-24512-00	.GASKET	1	
19	1A0-24512-00	.O-RING	1	
20	619-24535-00	.SCREW, lever fitting	1	
21	90202-06010	WASHER, plate	2	
22	90149-06011	SCREW	2	
23	5X7-2412F-00	BRACKET, seat	1	
24	92501-06012	SCREW, pan head	2	
25	92901-06100	WASHER, spring	2	
26	22W-24183-00	DAMPER, locating 3	1	
27	39K-24250-01	GRAPHIC SET	1	UR for U.S.A

C13

FIG. 22 FUEL TANK



REF. NO.	PART NO.	DESCRIPTION	Q'TY	REMARKS
27	39K-24250-11	GRAPHIC SET	1	UR for Canada

FIG. 23 SEAT

REF. NO.	PART NO.	DESCRIPTION	Q'TY	REMARKS
1	22W-24770-00	SEMI-DOUBLE SEAT ASSY	1	UR for U.S.A
2	22W-24771-00	.COVER, semi-double seat	1	black
3	22W-24770-10	SEMI-DOUBLE SEAT ASSY	1	UR for Canada
4	22W-24771-10	.COVER, semi-double seat	1	red

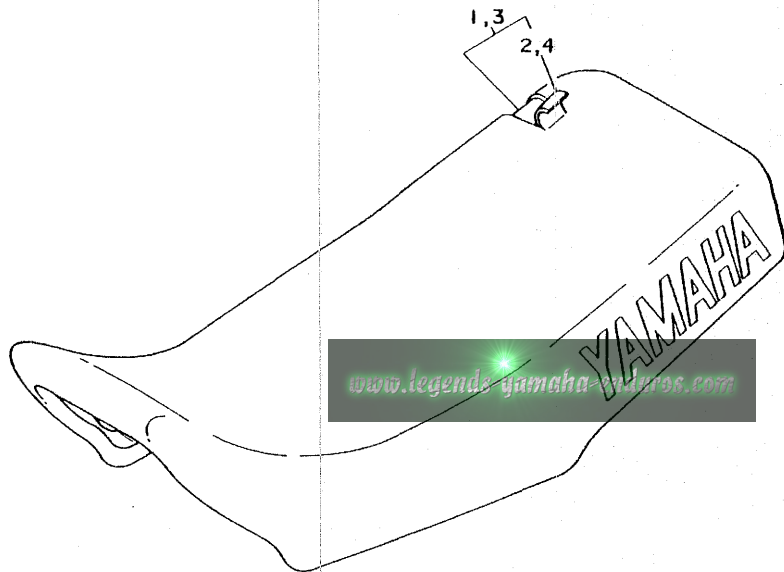



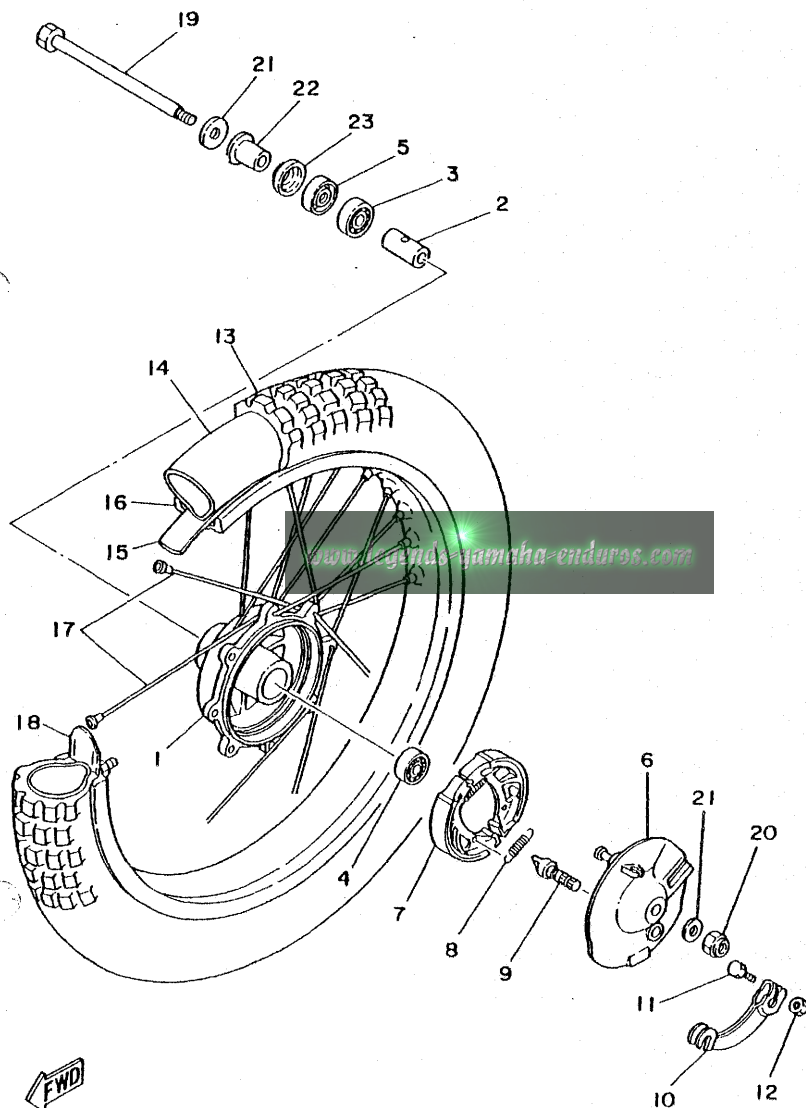

FIG. 24 FRONT WHEEL

REF. NO.	PART NO.	DESCRIPTION	Q'TY	REMARKS
1	39K-25111-00-98	HUB, front	1	low gloss black
2	90560-12257	SPACER	1	
3	93306-00105	BEARING (B6001)	1	
4	93306-00104	BEARING (B6001RS)	1	
5	93106-18013	OIL SEAL	1	
6	39K-25121-00-98	PLATE, brake shoe	1	low gloss black
7	39K-25130-00	BRAKE SHOE COMP.	2	
8	90506-14081	SPRING, tension	2	
9	451-25151-00	CAMSHAFT	1	
10	39K-25155-00	LEVER, camshaft 1	1	
11	90101-06291	BOLT	1	
12	95301-06600	NUT	1	
13	94108-170F1	TIRE	1	UR bridgestone
	94108-171F1	TIRE	1	UR inoue
14	94227-17152	TUBE (2.75-17)	1	UR bridgestone
	94227-17162	TUBE (2.75-17)	1	UR inoue
15	94327-17103	BAND, rim (2.75-17)	1	UR bridgestone
	94327-17079	BAND, rim (2.75-17)	1	UR inoue
16	94414-17374	RIM (1.40-17)	1	
17	39K-25104-00	SPOKE SET, front	1	
18	1T1-25194-00	SPACER, bead	1	
19	22W-25181-01	AXLE, wheel	1	
20	90185-12046	NUT, self-locking	1	
21	90201-12174	WASHER, plate	2	
22	2J5-25183-00	COLLAR, wheel	1	
23	462-25118-00	COVER, hub dust	1	

FWD  
39K100-4240

FIG. 25 REAR WHEEL

REF. NO.	PART NO.	DESCRIPTION	Q'TY	REMARKS
1	39K-25311-00-98	HUB, rear	1	low gloss black
2	90560-12256	SPACER	1	
3	93306-00104	BEARING (B6001RS)	1	
4	93306-00105	BEARING (B6001)	1	
5	93306-30101	BEARING (B6301)	1	
6	93106-20002	OIL SEAL	1	
7	39K-25321-00-98	PLATE, brake shoe	1	low gloss black
8	39K-25130-00	BRAKE SHOE COMP.	2	
9	90506-14081	SPRING, tension	2	
10	3R0-25351-00	CAMSHAFT	1	
11	3R0-25355-11	LEVER, camshaft	1	
12	90101-06278	BOLT	1	
13	95301-06600	NUT	1	
14	94111-147E9	TIRE	1	UR bridgestone
	94111-141F2	TIRE	1	UR inoue
15	94241-14175	TUBE (4.10-14)	1	UR bridgestone
	94232-14174	TUBE (3.25-14)	1	UR inoue
16	94336-14102	BAND, rim (3.60-14)	1	UR bridgestone
	94327-14106	BAND, rim (2.75-14)	1	UR inoue
17	94416-14375	RIM (1.60-14)	1	
18	39K-25304-00	SPOKE SET, rear	1	
19	5X2-25394-00	SPACER, bead	1	
20	39K-25448-00	SPROCKET, driven (48T)	1	
	39K-25444-00	SPROCKET, driven (44T)	1	AP
	39K-25446-00	SPROCKET, driven (46T)	1	AP
	39K-25450-00	SPROCKET, driven (50T)	1	AP
21	90109-08706	BOLT	4	
22	95611-08100	NUT, u	4	

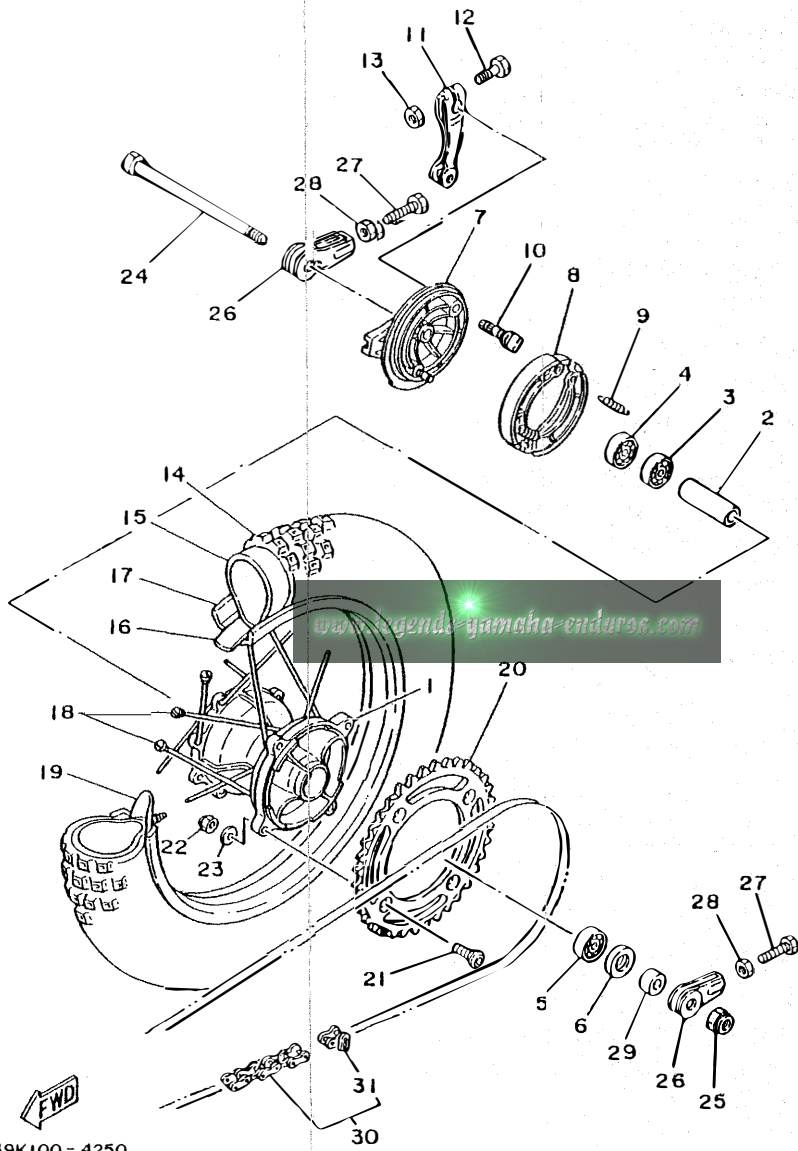

39K100-4250

D3

FIG. 25 REAR WHEEL

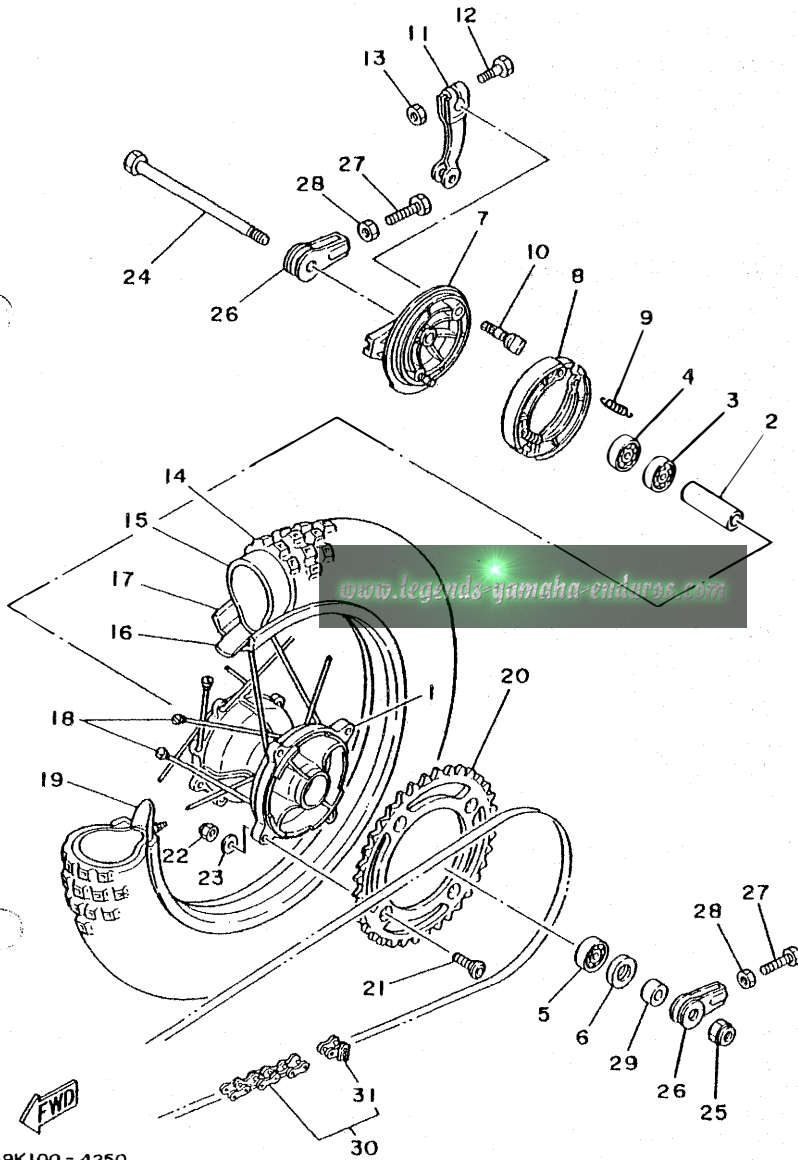

REF. NO.	PART NO.	DESCRIPTION	Q'TY	REMARKS
23	90201-081A6	WASHER, plate	4	
24	39K-25381-00	AXLE, wheel	1	
25	90185-12046	NUT, self-locking	1	
26	5H5-25389-00	PULLER, chain 2	2	
27	90101-08034	BOLT	2	
28	95301-08700	NUT	2	
29	90387-127J9	COLLAR	1	
30	94580-24114	CHAIN	1	
31	94680-24001	JOINT, chain	1	

39K100-4250

D4

FIG. 26 STEERING HANDLE. CABLE

REF. NO.	PART NO.	DESCRIPTION	Q'TY	REMARKS
1	22W-26111-00	HANDLEBAR	1	
2	4V4-26242-01	GRIP (R.H)	1	
3	22W-26243-00	TUBE, throttle guide	1	
4	688-82535-00	GROMMET	1	
5	4V4-26241-01	GRIP (L.H)	1	
6	5X2-26281-00	CAP, grip upper	1	
7	322-26282-00-98	CAP, grip lower	1	low gloss black
8	5X2-2628H-01	CAP, wire	1	
9	98606-04012	SCREW, oval head	2	
10	98506-05016	SCREW, pan head	2	
11	22W-26311-00	CABLE, throttle l	1	
12	39K-26341-00	CABLE, brake	1	
13	382-26372-01	.COVER, handle lever l	1	
14	39K-26335-00	CABLE, clutch	1	
15	382-26372-01	.COVER, handle lever l	1	
16	90123-08013	BOLT	2	
17	90179-08148	NUT	2	
18	437-83936-10	BAND, switch cord	1	

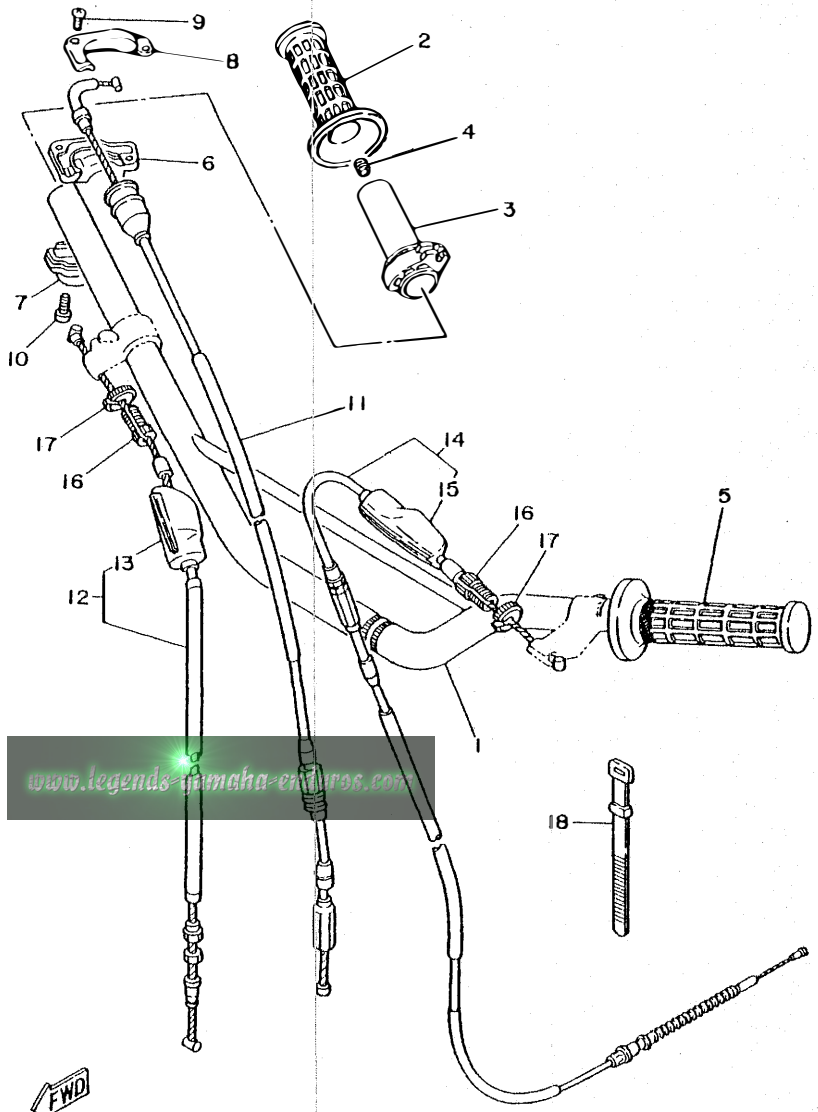

www.legends-jamaha-enturos.com



22W100-3270

D5

FIG. 27 STAND, FOOTREST

REF. NO.	PART NO.	DESCRIPTION	Q'TY	REMARKS
1	22W-27211-00	PEDAL, brake	1	
2	97301-06012	BOLT	1	
3	95301-06700	NUT	1	
4	90508-32468	SPRING, torsion	1	
5	93430-09019	CIRCLIP	1	
6	92902-12600	WASHER, plate	1	
7	39K-27231-00	ROD, brake	1	
8	90240-06040	PIN, clevis	1	
9	92901-06200	WASHER, plain	1	
10	91401-20015	PIN, cotter	1	
11	90501-10245	SPRING, compression	1	
12	90249-12008	PIN	1	
13	90175-06016	NUT, wing	1	
14	22W-27311-00-R4	STAND, side	1	black
15	22W-27321-00	BRACKET, side stand	1	
16	95821-10016	BOLT, flange	1	
17	90201-102A2	WASHER, plate	1	
18	90109-08666	BOLT	1	
19	90506-28100	SPRING, tension	1	
20	95301-08700	NUT	1	
21	22W-27411-00	FOOTREST 1	1	
22	90508-20023	SPRING, torsion	1	
23	90240-08097	PIN, clevis	1	
24	91401-25015	PIN, cotter	1	
25	5X2-27422-01-33	BRACKET, footrest 2	1	yamaha black
26	22W-27421-00	FOOTREST 2	1	
27	90240-08097	PIN, clevis	1	
28	91401-25012	PIN, cotter	1	

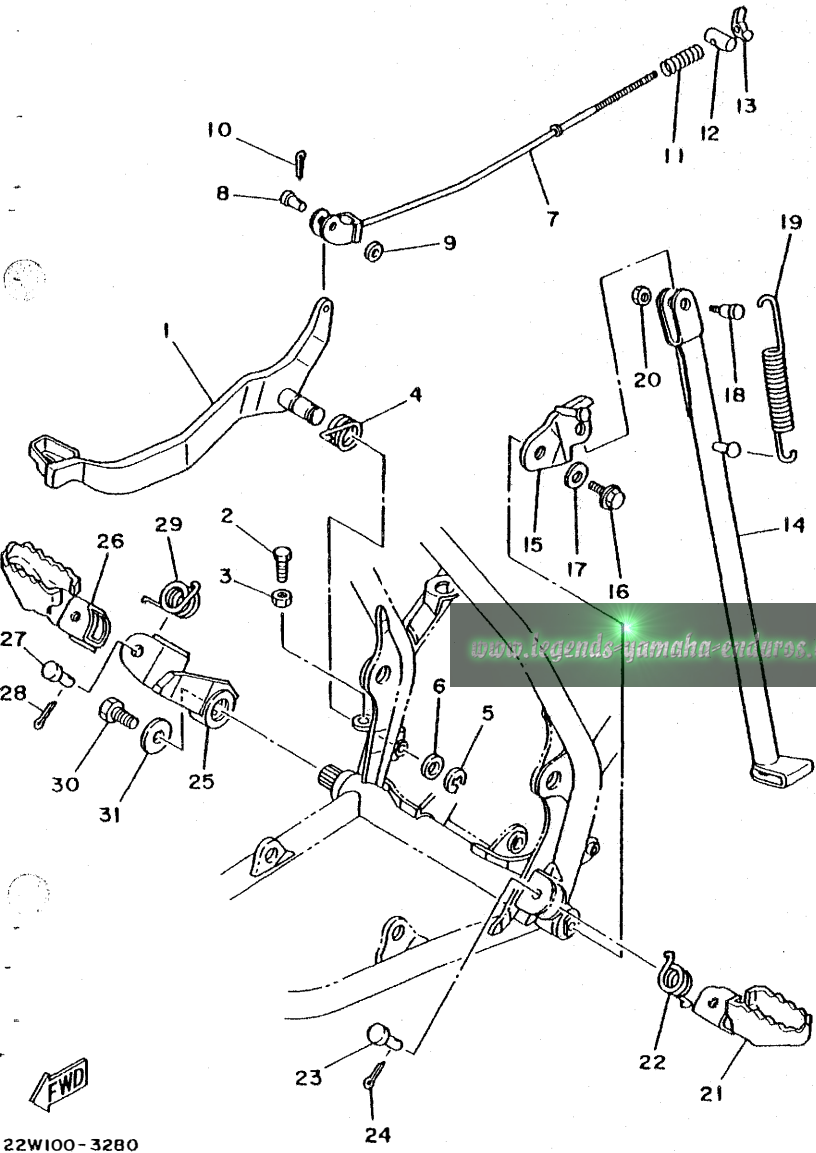

22W100-3280

D6

FIG. 27 STAND, FOOTREST

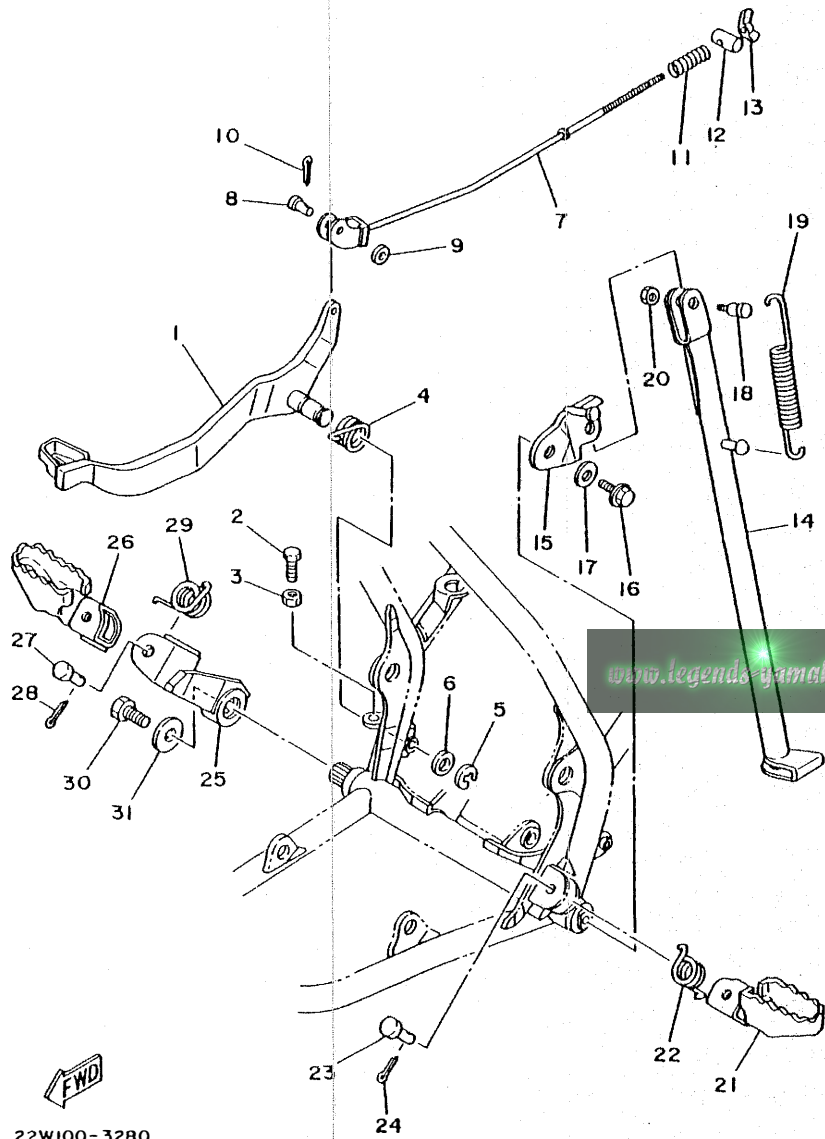

REF. NO.	PART NO.	DESCRIPTION	Q'TY	REMARKS
29	90508-20023	SPRING, torsion	1	
30	97311-10022	BOLT	1	
31	90201-10144	WASHER, plate	1	

FWD  
22W100-3280

D7

FIG. 28 GENERATOR

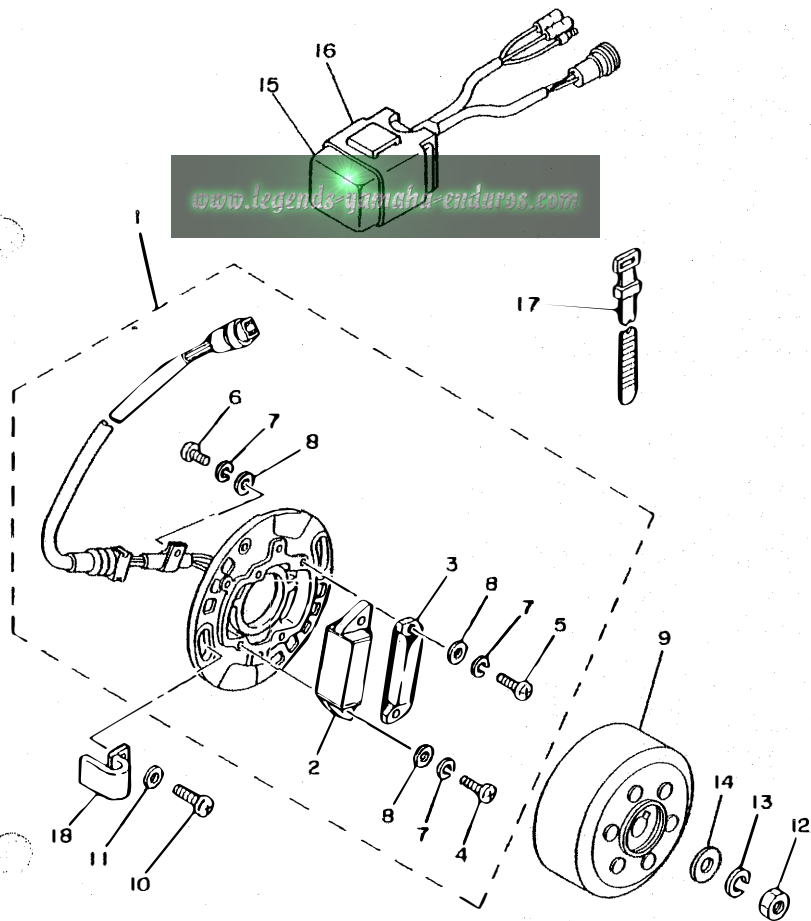

REF. NO.	PART NO.	DESCRIPTION	Q'TY	REMARKS
1	39K-85510-20	STATOR ASSY	1	
2	39K-85512-20	.COIL, source	1	
3	39K-85580-20	.COIL, pulser	1	
4	98501-04025	.SCREW, pan head	2	
5	98501-04014	.SCREW, pan head	2	
6	98502-04008	.SCREW, pan head	1	
7	92902-04100	.WASHER, spring	5	
8	92901-04600	.WASHER, plate	5	
9	39K-85550-20	ROTOR ASSY	1	
10	92501-06014	SCREW, pan head	2	
11	92901-06600	WASHER, plate	2	
12	95311-10600	NUT	1	
13	92901-10100	WASHER, spring	1	
14	90201-10591	WASHER, plate	1	
15	39K-85540-20	C.D.I. UNIT ASSY	1	
16	2A7-85546-00	BAND	1	
17	437-83936-10	BAND, switch cord	1	
18	90462-05005	CLAMP	1	



39K100-4280

FIG. 29 HANDLE SWITCH. LEVER

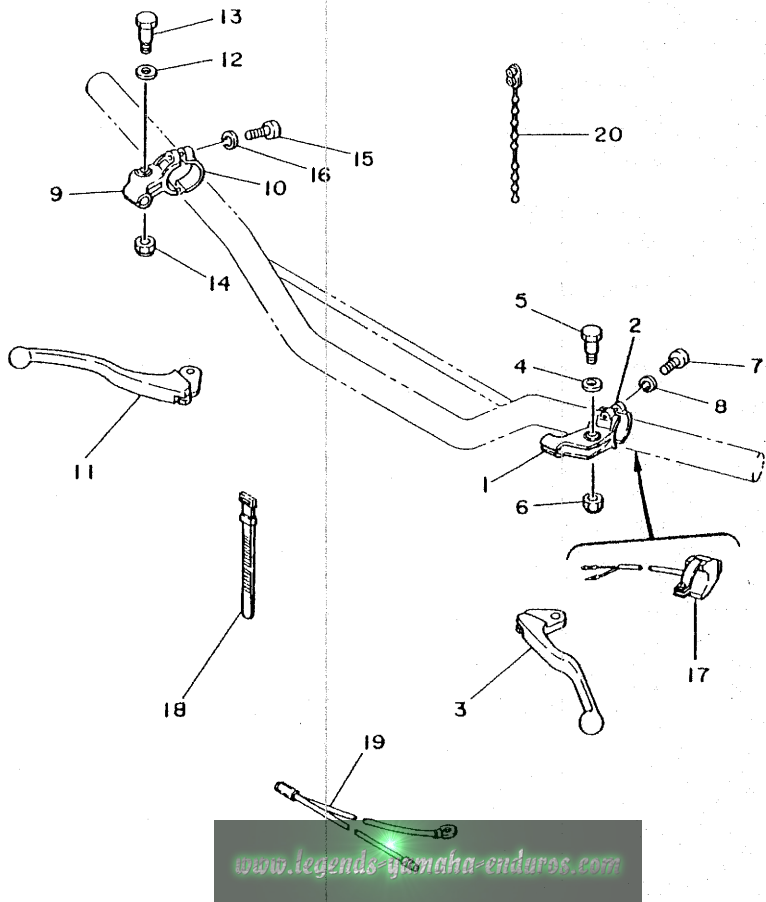

REF. NO.	PART NO.	DESCRIPTION	Q'TY	REMARKS
1	38V-82911-00	HOLDER, lever 1	1	
2	38V-82913-00	HOLDER, lever lower 1	1	
3	3R0-83912-01	LEVER 1	1	
4	90201-08083	WASHER, plate	1	
5	90109-06410	BOLT	1	
6	95601-06100	NUT, u	1	
7	98506-05018	SCREW, pan head	2	
8	92906-05100	WASHER, spring	2	
9	38V-82921-00	HOLDER, lever 2	1	
10	38V-82913-00	HOLDER, lever lower 1	1	
11	3R0-83922-01	LEVER 2	1	
12	90201-08083	WASHER, plate	1	
13	90109-06410	BOLT	1	
14	95601-06100	NUT, u	1	
15	98506-05018	SCREW, pan head	2	
16	92906-05100	WASHER, spring	2	
17	22W-83976-00	SWITCH, handle 1	1	
18	437-83936-00	BAND, switch cord	1	
19	5X1-82519-00	WIRE, earth lead	1	
20	90464-20031	CLAMP	1	

[www.legends-yamaha-enduros.com](http://www.legends-yamaha-enduros.com)



39K100-4290

D9



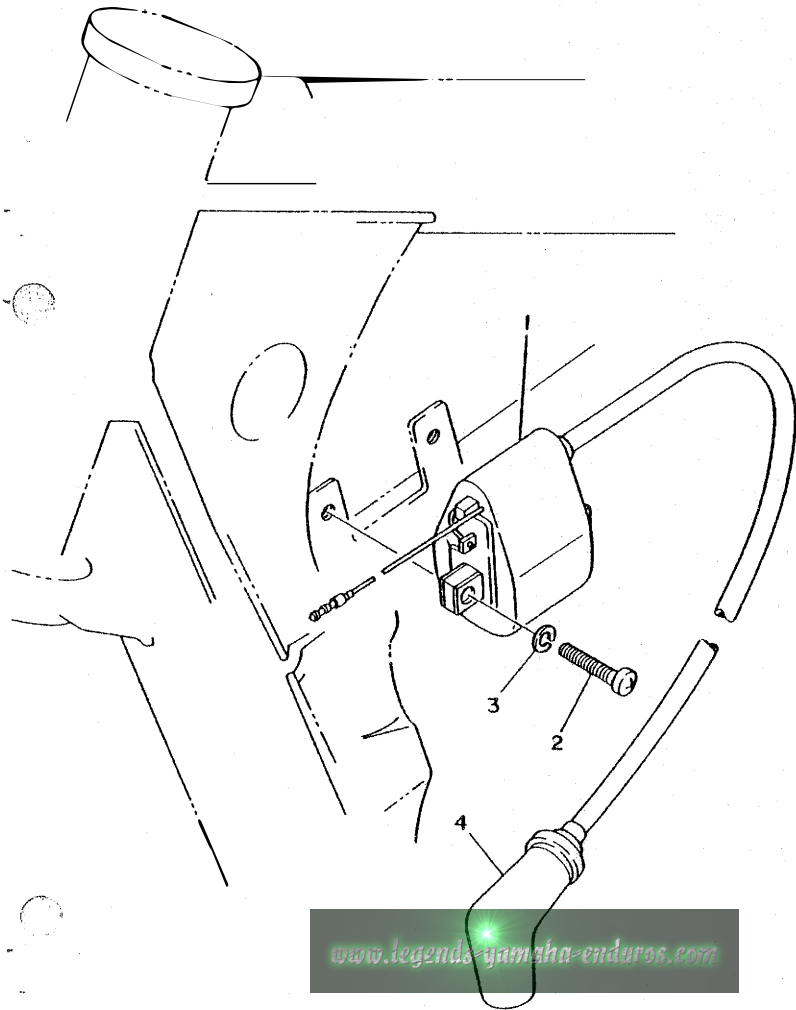

FIG. 30 ELECTRICAL 1

REF. NO.	PART NO.	DESCRIPTION	Q'TY	REMARKS
1	39K-82310-40	IGNITION COIL ASSY	1	
2	92501-06020	SCREW, pan head	2	
3	92902-06100	WASHER, spring	2	
4	3R0-82370-20	PLUG CAP ASSY	1	UR
	1M1-82370-21	PLUG CAP ASSY	1	UR with noisesuppressor



22W100-3291

FIG. 31 ALTERNATE (CHASSIS)

REF. NO.	PART NO.	DESCRIPTION	Q'TY	REMARKS
1	39K-23141-20	SPRING, front fork	2	hard
2	22W-22212-30-26	SPRING	1	UR hard competition yellow
	22W-22212-30-6W	SPRING	1	UR hard native red

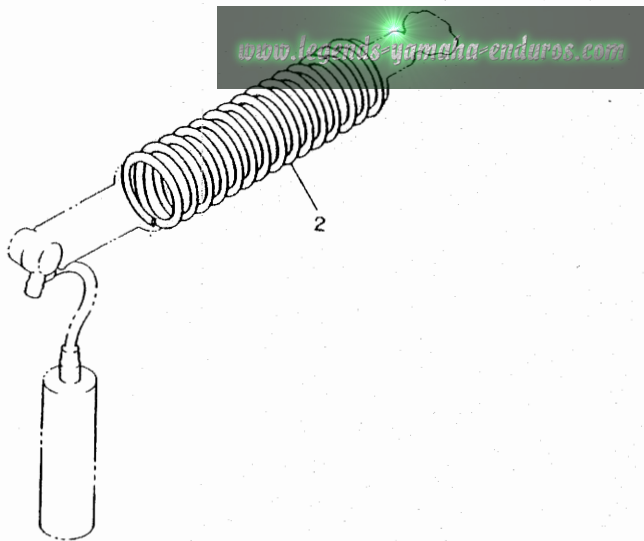
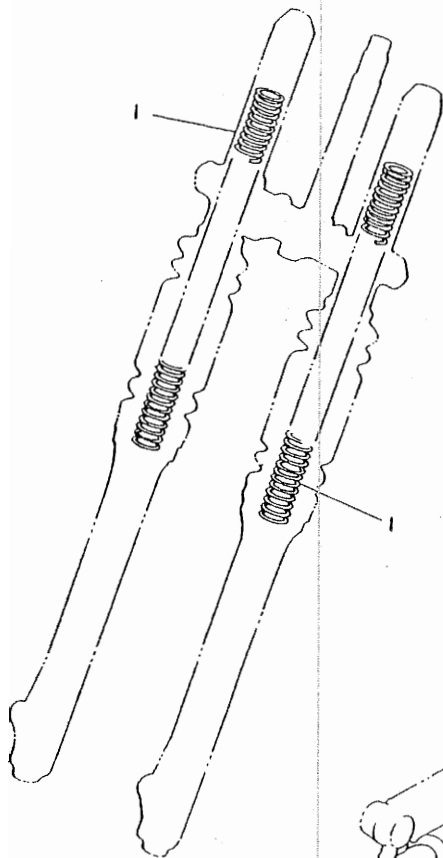

22W100-3311

D11

FIG. 32 REPAIR KIT

REF. NO.	PART NO.	DESCRIPTION	Q'TY	REMARKS
1	39K-11630-00	PISTON ASSY (STD)	1	
2	39K-11631-00-94	.PISTON (STD)	1	
3	39K-11611-00	.RING, piston	1	
4	4V1-11633-00	.PIN, piston	1	
5	5X2-11634-00	.CLIP, piston pin	2	
6	39K-11630-10	PISTON ASSY (1ST O/S)	1	
7	39K-11635-00	.PISTON (0.25MM O/S)	1	
8	39K-11611-10	.RING, piston	1	
9	4V1-11633-00	.PIN, piston	1	
10	5X2-11634-00	.CLIP, piston pin	2	
11	39K-11630-20	PISTON ASSY (2ND O/S)	1	
12	39K-11636-00	.PISTON (0.50MM O/S)	1	
13	39K-11611-20	.RING, piston	1	
14	4V1-11633-00	.PIN, piston	1	
15	5X2-11634-00	.CLIP, piston pin	2	
16	39K-11650-00	CONNECTING ROD ASSY	1	
17	39K-11651-00	.ROD, connecting	1	
18	93310-418M6	.BEARING, cylindrical	1	
19	4V0-11681-00	.PIN, crank 1	1	
20	90209-18112	.WASHER	2	
21	93310-312M5	.BEARING, cylindrical	1	

[www.legends-yamaha-enduros.com](http://www.legends-yamaha-enduros.com)

NUMERICAL INDEX

PART NO.	GRID NO.	PART NO.	GRID NO.	PART NO.	GRID NO.	PART NO.	GRID NO.	PART NO.	GRID NO.	PART NO.	GRID NO.
39K-11111-00	B- 2	5X2-13565-00	B- 6	4J2-15363-00	B-11	5X5-18531-01	B-15	22W-22212-20-6W	C- 8	22W-23146-L0	C-12
39K-11181-00	B- 2	22W-13581-00	B- 7	3R4-15383-01	B-14	5X5-18535-01	B-15	22W-22212-30-26	D-11	3J2-23147-00	C-11
39K-11311-00	B- 2	22W-13610-00	B- 6	4V0-15411-00	B-11	22W-18540-00	B-15	22W-22212-30-6W	D-11		C-12
4V0-11351-00	B- 2	1LB-13613-00	B- 6	22W-15421-00	B-11	39K-21110-00-FH	C- 3	3R4-22213-00	C- 8	509-23151-L0	C-11
39K-11400-00	B- 3	10V-13616-01	B- 6	22W-15451-00	B-11	39K-21110-00-33	C- 3	22W-22214-00	C- 8		C-12
39K-11412-00	B- 3	39K-13621-00	B- 6	5X2-15462-00	B-11	5X2-21511-00	C- 4	2X6-22216-00	C- 8	22W-23153-L0	C-11
39K-11422-00	B- 3	39K-14101-00	B- 8	4V0-15618-00	B-12	5X2-21511-10	C- 4	3R4-22221-01	C- 8		C-12
39K-11611-00	B- 3	10W-14103-00	B- 8	22W-15620-00	B-12	22W-21523-00	C- 4	22W-22223-00	C- 8	22W-23157-L0	C-11
	D-12	10W-14104-00	B- 8	4V0-15621-00	B-12	22W-21611-00	C- 4	5X2-22228-00	C- 8		C-12
39K-11611-10	B- 3	22W-14106-00	B- 8	39K-15641-00	B-12	22W-21611-10	C- 4	24X-22261-00	C- 9	509-23158-L0	C-11
	D-12	23L-14107-25	B- 8	39K-15651-00	B-12	39K-21620-00	C- 4	24X-22262-00	C- 9		C-12
39K-11611-20	B- 3	2X6-14112-20	B- 8	22W-15660-00	B-12	4V0-21621-00	C- 4	39K-22401-00	C- 8	39K-23170-L0	C-11
	D-12	3R1-14115-00	B- 8	4V0-15664-00	B-12	39K-21711-00	C- 5	22W-22409-00	C- 8		C-12
39K-11630-00	D-12	2A6-14126-00	B- 8	39K-16111-00	B-13	39K-21711-10	C- 5	39K-22472-00	C- 8	3R8-23173-L0	C-11
39K-11630-10	D-12	248-14131-00	B- 8	39K-16150-00	B-13	39K-2172A-00	C- 5	29L-22475-00	C- 8		C-12
39K-11630-20	D-12	3R1-14141-44	B- 8	4V0-16154-00	B-13	39K-21721-00	C- 5	22W-22489-00	C- 8	278-23181-50	C-11
39K-11631-00-94	B- 3	260-14142-35	B- 8	4V0-16321-00	B-13	39K-21721-10	C- 5	5X2-22493-00	C- 8		C-12
	D-12	137-14143-46	B- 8	598-16324-00	B-13	39K-2174F-00	C- 3	3R4-22497-00	C- 8	23X-23190-L0	C-11
39K-11631-00-95	B- 3	137-14143-48	B- 8	4Y2-16351-01	B-13	39K-21741-00	C- 5	39K-23102-L0	C-11		C-12
4V1-11633-00	B- 3	137-14143-50	B- 8	137-16356-00	B-13	39K-21741-10	C- 5	39K-23103-L0	C-11	39K-23340-L0-39	C-12
	D-12	3R1-14153-00	B- 8	2X3-16357-00	B-13	22W-21746-00	C- 5	22W-23110-L0	C-11	3R4-23389-00	C-10
	D-12	2A6-14158-00	B- 8	1V1-16371-02	B-13	39K-21781-00	B- 6		C-11	122-23411-00	C-10
	D-12	3X3-14169-00	B- 8	39K-16382-00	B-13		C- 5	22W-23111-L0	C-11	122-23412-00	C-10
5X2-11634-00	B- 3	4U5-14171-00	B- 8	4V0-17121-00	B-14	39K-21781-10	B- 6		C-12	122-23416-00	C-10
	D-12	304-14184-00	B- 8	39K-17131-00	B-14		C- 5	3J2-23114-00	C-11	22W-23435-00-98	C-10
	D-12	314-14185-00	B- 8	39K-17151-00	B-14	3R1-21782-00	C- 5		C-12	1E6-23441-00	C-10
	D-12	127-14186-00	B- 8	39K-17161-00	B-14		C- 5	15R-23118-00	C-11	22W-23485-01	C-10
39K-11635-00	B- 3	183-14196-00	B- 8	4V0-17211-00	B-14	22W-21785-00	C-10		C-12	22W-23485-11	C-10
	D-12	39K-14401-00	B- 6	39K-17221-00	B-14	22W-21791-00	C- 5	122-23119-01	C-11	22W-24110-00	C-13
39K-11636-00	B- 3	39K-14402-00	B- 6	4V0-17231-00	B-14	39K-22110-00-35	C- 6		C-12	22W-24110-10	C-13
	D-12	43K-14402-00	B- 6	39K-17241-00	B-14	22W-22124-00	C- 6	22W-2312K-00	C-11	5X7-2412F-00	C-13
39K-11650-00	D-12	5X5-1441L-00	B- 6	39K-17251-00	B-14	401-22127-00	C- 6		C-11	22W-24158-00	C-13
39K-11651-00	B- 3	39K-14451-00	B- 6	39K-17261-00	B-14	401-22128-01	C- 6	22W-23125-L0	C-11	3R3-24173-00	C-13
	D-12	39K-14452-00	B- 6	4V0-17411-01	B-14	22W-22129-00	C- 7		C-12	22W-24181-00	B- 5
4V0-11681-00	B- 3	39K-14453-00	B- 6	22W-17421-00	B-14		C- 8	39K-23126-L0	C-11		C- 5
	D-12	39K-14457-00	B- 6	164-17427-00-06	B-14	5X6-22129-00	C- 6	122-23129-00	C-11	22W-24183-00	C-13
39K-12422-00	B- 4	39K-14458-00	B- 6	174-17461-20	B-14	4V1-22141-00	C- 6		C-12	39K-24250-01	C-13
5X2-12428-00	B- 4	39K-14467-00	B- 6	174-17461-30	B-14	39K-22151-00	C- 6	39K-23136-L0	C-11	39K-24250-11	C-14
39K-12446-00	B- 5	4V2-14468-01	B- 6	174-17461-40	B-14	39K-2217A-00	C- 6	39K-23141-00	C-11	2K5-24500-00	C-13
22W-12450-00	B- 4	39K-14610-00	B- 9	174-17461-50	B-14	22W-2217F-00	C- 7		C-12	1A0-24512-00	C-13
39K-12459-00	B- 4	22W-14613-00	B- 9	22W-18101-00	C- 2	22W-22178-01	C- 3	39K-23141-20	D-11	214-24512-00	C-13
39K-12460-00	B- 5	39K-14718-00	B- 9	22W-18110-00	C- 2	5X1-2218A-00	C- 6	583-23142-00	C-11	619-24535-00	C-13
22W-12462-00	B- 5	39K-14753-00	B- 9	102-18137-00-10	B-12	4V4-22184-00	C- 3		C-12	5X7-24611-01	C-13
22W-12463-00	B- 5	565-14771-00	B- 9	22W-18140-00	B-15	22W-22189-00	C- 9	22W-23144-L0	C-11	5X7-24612-00	C-13
39K-12481-00	B- 5	22W-1490J-00	B- 8	1W1-18177-00	B-15	39K-22199-00	C- 6		C-12	22W-24770-00	C-15
39K-12482-00	B- 5	39K-15111-00	B-10	4V0-18511-00	B-15	39K-22210-00-26	C- 8	22W-23145-L0	C-11	22W-24770-10	C-15
4V2-12494-00	B- 5	5X2-15113-00	B-10	39K-18512-00	B-15	39K-22210-00-6W	C- 8		C-12	22W-24771-00	C-15
353-13115-01	B-10	39K-15121-00	B-10	4V0-18513-00	B-15	22W-22212-20-26	C- 8	22W-23146-L0	C-11	22W-24771-10	C-15

www.legends-yamaha-enduros.com



NUMERICAL INDEX

PART NO.	GRID NO.	PART NO.	GRID NO.	PART NO.	GRID NO.	PART NO.	GRID NO.	PART NO.	GRID NO.	PART NO.	GRID NO.
39K-25104-00	D- 2	38V-82911-00	D- 9	90179-12335	B-13	90240-08097	D- 6	90480-18290	C-13	92901-06100	C-13
39K-25111-00-98	D- 2	38V-82913-00	D- 9	90179-25033	C-10		D- 6	90501-10245	D- 6		C-13
462-25118-00	D- 2		D- 9	90185-08113	C- 3	90249-12008	D- 6	90501-12081	B-12	92901-06200	D- 6
39K-25121-00-98	D- 2	38V-82921-00	D- 9		C- 4	90250-06013	B-15	90501-20644	B-13	92901-06600	B- 6
39K-25130-00	D- 2	3R0-83912-01	D- 9		C- 6	90280-03017	B- 3	90504-03033	B- 6		B- 9
	D- 3	3R0-83922-01	D- 9	90185-10110	C- 6	90282-05001	B-13	90506-14081	D- 2		D- 8
451-25151-00	D- 2	437-83936-00	C- 4		C- 7	90338-07011	B-10		D- 3	92901-08100	C-12
39K-25155-00	D- 2		D- 9		C- 7	90340-12095	B-10	90506-28100	D- 6	92901-10100	D- 8
22W-25181-01	D- 2	437-83936-10	D- 5		C- 8	90380-12094	C- 6	90507-20030	B- 9	92901-10600	C- 7
2J5-25183-00	D- 2		D- 8		C- 9	90380-16109	C- 6	90508-18463	B-13		C- 7
1T1-25194-00	D- 2	22W-83976-00	D- 9	90185-12046	D- 2	90381-08002	B- 4	90508-20023	D- 6		C- 8
39K-25304-00	D- 3	39K-85510-20	D- 8		D- 4	90383-16023	C- 7		D- 7		C- 9
39K-25311-00-98	D- 3	39K-85512-20	D- 8	90185-12119	C- 6		C- 7	90508-26462	B-15	92902-04100	B- 8
39K-25321-00-98	D- 3	39K-85540-20	D- 8	90201-05775	B-13	90384-18190	C- 6	90508-26464	B-12		D- 8
3R0-25351-00	D- 3	2A7-85546-00	D- 8	90201-06067	C- 6	90385-17042	C- 6	90508-32465	C- 2	92902-06100	C- 4
3R0-25355-11	D- 3	39K-85550-20	D- 8	90201-06072	C-13	90387-07392	B- 5	90508-32468	D- 6		D-10
39K-25381-00	D- 4	39K-85580-20	D- 8		C-13	90387-07598	C-13	90560-12256	D- 3	92902-06700	C- 3
5H5-25389-00	D- 4	90101-06278	D- 3	90201-06557	C- 4		C-13	90560-12257	D- 2	92902-12600	D- 6
5X2-25394-00	D- 3	90101-06291	D- 2	90201-06570	B- 5	90387-10569	C- 7	91401-20015	D- 6	92906-05100	D- 9
39K-25444-00	D- 3	90101-08034	D- 4	90201-06571	C- 5	90387-10660	C- 7	91401-25012	D- 6		D- 9
39K-25446-00	D- 3	90105-14137	C-10		C- 5		C- 8	91401-25015	D- 6	92906-06600	B- 6
39K-25448-00	D- 3	90109-06410	D- 9	90201-067A0	C- 3	90387-127J7	C- 6	91830-21014	B-11	93102-20143	B-14
39K-25450-00	D- 3		D- 9	90201-08083	D- 9	90387-127J8	C- 6	91830-22016	B-10	93102-20231	B- 3
22W-26111-00	D- 5	90109-08666	D- 6		D- 9	90387-127J9	D- 4	92501-06012	B-10	93103-10113	B- 4
4V4-26241-01	D- 5	90109-08706	D- 3	90201-08085	B- 4	90387-202F0	B-13		C-10	93103-28126	B- 3
4V4-26242-01	D- 5	90109-10688	C- 7	90201-081A6	D- 4	90430-06016	B-11		C-13	93106-18013	D- 2
22W-26243-00	D- 5	90109-10689	C- 7	90201-08649	B- 2	90430-06166	B- 2	92501-06014	C- 5	93106-20002	D- 3
5X2-26284-01	D- 5		C- 8	90201-08730	C- 4		B- 4		C- 5	93109-12012	C- 2
5X2-26281-00	D- 5	90109-10690	C- 6	90201-100E9	C- 6	90430-12038	B-10		D- 8	93109-14021	B-13
322-26282-00-98	D- 5	90109-10729	C- 8	90201-10144	D- 7	90445-08376	B-10	92501-06020	D-10	93109-15001	B-12
22W-26311-00	D- 5	90116-08438	B- 2	90201-102A2	D- 6	90445-09304	C-13	92501-06035	B-10	93109-16035	C- 7
39K-26335-00	D- 5	90119-06043	B- 7	90201-10591	D- 8	90445-16673	B- 7	92501-06045	B-10	93109-17048	C- 6
39K-26341-00	D- 5	90119-06063	C- 4	90201-10614	B- 4	90460-22252	B- 5	92502-06016	C- 4	93210-14104	B-11
382-26372-01	D- 5	90119-06073	C-13	90201-12174	D- 2	90460-31253	B- 5	92506-06008	B-11	93210-16275	B- 5
	D- 5		C-13	90201-12469	C- 6	90460-43053	B- 6	92506-06016	B- 5	93210-18288	B- 8
22W-27211-00	D- 6	90119-06080	B- 5	90201-12631	B-12	90460-51059	B- 6		B- 6	93306-00104	D- 2
39K-27231-00	D- 6	90119-06085	B- 7	90201-14411	B-13	90460-58124	B- 6	92506-06020	B- 4		D- 3
22W-27311-00-R4	D- 6	90123-08013	D- 5	90201-154A1	B-12	90462-05005	D- 8	92506-06025	B-11	93306-00105	D- 2
22W-27321-00	D- 6	90149-06011	C-13	90201-174H1	C- 6	90462-14055	C-10	92506-06030	B-11		D- 3
22W-27411-00	D- 6	90153-06045	B- 2	90202-06010	B- 9	90464-20031	D- 9	92506-06040	B-11	93306-20333	B-14
22W-27421-00	D- 6	90159-05100	C- 5		C-13	90467-08004	B- 5	92506-06060	B- 4	93306-20401	B-14
5X2-27422-01-33	D- 6	90159-05101	C- 5	90206-12082	C- 8	90467-16063	B- 7	92701-06012	B-14	93306-20438	B- 3
39K-28100-00	C- 3	90159-06060	C-10	90208-12015	B-13	90468-26046	B-12	92901-04600	D- 8	93306-30101	D- 3
39K-82310-40	D-10	90170-20213	C- 8		B-13	90480-12053	C- 5	92901-06100	B- 7	93310-312M5	B- 3
1M1-82370-21	D-10	90175-06016	D- 6	90209-06187	C- 4	90480-13197	B- 7		B- 9		D-12
3R0-82370-20	D-10	90179-08148	D- 5	90209-18112	B- 3	90480-15064	B- 5		C- 5	93310-418M6	B- 3
5X1-82519-00	D- 9	90179-10272	B-12		D-12	90480-17359	C- 9		C- 5		D-12
688-82535-00	D- 5	90179-12244	B-13	90240-06040	D- 6	90480-18290	C-13		C-10	93315-21429	B-13

NUMERICAL INDEX

PART NO.	GRID NO.	PART NO.	GRID NO.	PART NO.	GRID NO.	PART NO.	GRID NO.	PART NO.	GRID NO.
93315-31502	B-14	95801-06025	C-6						
93317-11245	B-14	95801-08020	C-4						
93317-21746	C-6	95801-08025	C-4						
93332-00059	C-10	95801-08035	C-10						
93410-12003	B-12	95811-08125	C-3						
93410-18062	B-14	95811-08135	C-3						
93410-20038	B-14	95821-08030	C-10						
93430-07012	B-4	95821-08040	C-6						
93430-08007	B-12	95821-10016	D-6						
93430-09019	D-6	95826-06020	B-4						
93430-10016	C-2	97301-06012	B-7						
93440-15012	B-14		C-13						
93440-16089	B-14		D-6						
93440-42101	C-8	97301-06016	B-9						
93503-16010	B-13		C-3						
	C-10	97301-06025	B-6						
93507-32009	B-12	97311-10022	D-7						
93603-22028	B-4	97321-06020	C-2						
93604-10011	B-4	97321-08035	C-12						
93604-26132	C-8	97602-03108	B-6						
93608-30128	C-2	97702-40116	B-6						
94108-170F1	D-2	98501-04005	C-8						
94108-171F1	D-2	98501-04014	D-8						
94111-141F2	D-3	98501-04025	D-8						
94111-147E9	D-3	98502-04008	D-8						
94227-17152	D-2	98506-05016	D-5						
94227-17162	D-2	98506-05018	D-9						
94232-14174	D-3		D-9						
94241-14175	D-3	98511-04016	B-8						
94327-14106	D-3	98606-04012	D-5						
94327-17079	D-2	98701-05020	B-13						
94327-17103	D-2	98906-06008	B-9						
94336-14102	D-3								
94414-17374	D-2								
94416-14375	D-3								
94580-24114	D-4								
94680-24001	D-4								
95021-08012	C-3								
95301-06600	D-2								
	D-3								
95301-06700	D-6								
95301-08700	D-4								
	D-6								
95311-08600	B-2								
95311-10600	D-8								
95601-06100	D-9								
	D-9								
95611-08100	D-3								

[www.legends-yamaha-enduros.com](http://www.legends-yamaha-enduros.com)

PARTS NAME INDEX

DESCRIPTION	GRID NO.	DESCRIPTION	GRID NO.	DESCRIPTION	GRID NO.
AIR CLEANER CASE ASSY	B- 6	BOLT	C-13	CAMSHAFT	D- 3
AIR SCREW SET	B- 8	*	D- 2	CAP	B- 8
AIR VALVE COMP.	C-11	*	D- 3	CAP ASSY, air cleaner	B- 6
*	C-12	*	D- 4	CAP, case	C- 8
ARM, relay	C- 6	*	D- 5	CAP, grip lower	D- 5
AXLE, drive	B-14	*	D- 6	CAP, grip upper	D- 5
AXLE, main	B-14	*	D- 7	CAP, radiator	B- 5
AXLE, push lever	B-13	*	D- 9	CAP, wire	D- 5
AXLE, wheel	D- 2	BOLT, cap	C-11	CARBURETOR ASSY 1	B- 8
*	D- 4	*	C-12	CHAIN	D- 4
BALL	B-12	BOLT, flange	B- 4	CHAMBER, air	B- 7
*	B-13	*	C- 3	CIRCLIP	B- 4
*	C-10	*	C- 4	*	B-12
BAND	D- 8	*	C- 6	*	B-14
BAND, rim (2.75-14)	D- 3	*	C-10	*	C- 2
BAND, rim (2.75-17)	D- 2	*	D- 6	*	C- 8
BAND, rim (3.60-14)	D- 3	BOLT, hexagon socket head	C-11	*	D- 6
BAND, switch cord	C- 4	*	C-12	CLAMP	C-10
*	D- 5	BOLT, stopper	B-15	*	D- 8
*	D- 8	BOLT, stud	B- 2	*	D- 9
*	D- 9	BOLT, washer based	C-10	CLAMP, hose	B- 5
BAND, tank fitting 1	C-13	BOLT, with washer	B- 5	*	B- 6
BAR, shift fork guide 1	B-15	*	B- 7	CLIP	B- 5
BAR, shift fork guide 2	B-15	*	C- 4	*	B- 7
BEARING	B- 3	*	C-13	*	B-12
*	B-14	BOOT, rubber	C- 9	CLIP, piston pin	B- 3
*	C-10	BOSS, clutch	B-13	*	D-12
BEARING (B6001)	D- 2	BOSS, kick crank	B-12	COIL, pulser	D- 8
*	D- 3	BRACKET, footrest 2	D- 6	COIL, source	D- 8
BEARING (B6001RS)	D- 2	BRACKET, seat	C-13	COLLAR	B- 5
*	D- 3	BRACKET, side stand	D- 6	*	B-13
BEARING (B6204)	B-14	BRAKE SHOE COMP.	D- 2	*	C- 6
BEARING (B6301)	D- 3	*	D- 3	*	C- 7
BEARING, cylindrical	B- 3	BUMP, stop	C- 8	*	C- 8
*	B-13	BUSH	C- 3	*	C-13
*	B-14	*	C- 6	*	D- 4
*	C- 6	BUSH 2	C- 6	COLLAR, wheel	D- 2
*	D-12	BUSH, bimetal formed	C- 6	CONNECTING ROD ASSY	D-12
BODY, cap	C-13	BUSH, formed	C- 7	CONNECTOR, suction pipe	B-10
BOLT	B- 6	BUSH, rear shock absorber	C- 8	COVER	C- 8
*	B- 7	BUSH, solid	B- 4	COVER, ball race 2	C-10
*	B- 9	*	C- 6	COVER, crankcase 1	B-11
*	C- 2	C.D.I. UNIT ASSY	D- 8	COVER, crankcase 2	B-11
*	C- 3	CABLE ADJUST SCREW SET	B- 8	COVER, handle lever 1	D- 5
*	C- 6	CABLE, brake	D- 5	COVER, housing	B- 4
*	C- 7	CABLE, clutch	D- 5	COVER, hub dust	D- 2
*	C- 8	CABLE, throttle 1	D- 5	COVER, kick lever	B-12
*	C-12	CAMSHAFT	D- 2	COVER, semi-double seat	C-15

www.legends-yamaha-enduros.com

## PARTS NAME INDEX

DESCRIPTION	GRID NO.	DESCRIPTION	GRID NO.	DESCRIPTION	GRID NO.
COVER, side 1	C- 5	GASKET	C-12	HOLDER, sub tank	C- 9
COVER, side 2	C- 5	*	C-13	HOSE	B- 7
COVER, side 4	C- 5	GASKET, cap	C-13	*	B-10
COVER, thrust 2	C- 6	GASKET, crankcase cover 1	B-11	*	C-13
*	C- 7	GASKET, crankcase cover 3	B-11	HUB, front	D- 2
*	C- 8	GASKET, cylinder	B- 2	HUB, rear	D- 3
CRANK 1	B- 3	GASKET, cylinder head 1	B- 2	IGNITION COIL ASSY	D-10
CRANK 2	B- 3	GASKET, drain plug	C-11	IMPELLER SHAFT ASSY	B- 4
CRANKCASE 1	B-10	*	C-12	INNER TUBE COMP. 1	C-11
CRANKCASE 2	B-10	GASKET, exhaust pipe	B- 9	JET, main (#230)	B- 8
CRANKSHAFT ASSY	B- 3	GASKET, float chamber	B- 8	JET, main (#240)	B- 8
CROWN, handle	C-10	GASKET, housing cover 2	B- 4	JET, main (#250)	B- 8
CYLINDER 1	B- 2	GASKET, valve seat	B- 6	JET, pilot (# 35)	B- 8
CYLINDER COMP., front fork	C-11	GEAR, 1st wheel (36T)	B-14	JOINT	B- 5
*	C-12	GEAR, 2nd pinion (16T)	B-14	JOINT, air cleaner 1	B- 6
DAMPER	C- 5	GEAR, 2nd wheel (33T)	B-14	JOINT, carburetor	B- 6
DAMPER SUB ASSY	C- 8	GEAR, 3rd pinion (16T/19T)	B-14	JOINT, chain	D- 4
DAMPER, locating 1	B- 5	GEAR, 3rd wheel (31T)	B-14	KEY, straight	B-13
*	C- 5	GEAR, 4th wheel (22T)	B-14	KEY, woodruff	B- 3
DAMPER, locating 3	C-13	GEAR, 5th pinion (22T)	B-14	KICK AXLE ASSY	B-12
DAMPER, sub tank	C- 9	GEAR, 5th wheel (27T)	B-14	KICK CRANK ASSY	B-12
ELEMENT, air cleaner	B- 6	GEAR, 6th pinion (23T)	B-14	LEVER 1	D- 9
EMBLEM 1	B- 6	GEAR, 6th wheel (26T)	B-14	LEVER 2	D- 9
*	C- 5	GEAR, impeller shaft	B- 4	LEVER, camshaft	D- 3
EMBLEM 2	C- 5	GEAR, kick (24T)	B-12	LEVER, camshaft 1	D- 2
EMBLEM 5	C-10	GEAR, kick idle	B-12	METAL, slide 1	C-11
EMBLEM, rear arm	C- 6	GEAR, primary drive	B-13	*	C-12
EXHAUST PIPE ASSY 1	B- 9	GRAPHIC SET	C-13	MUD GUARD COMP.	C- 4
FENDER, front	C- 4	*	C-14	NEEDLE SET	B- 8
FENDER, rear	C- 4	GRIP (L.H)	D- 5	NEEDLE VALVE SET	B- 8
FLAP	C- 4	GRIP (R.H)	D- 5	NOZZLE, main	B- 8
FLOAT	B- 8	GROMMET	B- 5	NUT	B- 2
FOOTREST 1	D- 6	*	B- 7	*	B-12
FOOTREST 2	D- 6	*	C- 5	*	B-13
FORK, shift 1	B-15	*	C- 9	*	C- 5
FORK, shift 2	B-15	*	C-13	*	C- 8
FORK, shift 3	B-15	*	D- 5	*	C-10
FRAME COMP.	C- 3	GUARD, radiator	C- 3	*	D- 2
FRONT FORK ASSY (L.H)	C-11	GUIDE	B- 6	*	D- 3
FRONT FORK ASSY (R.H)	C-11	GUIDE, cable	C-10	*	D- 4
FUEL COCK ASSY 1	C-13	GUIDE, spring	B-12	*	D- 5
FUEL TANK COMP.	C-13	GUIDE, spring 1	C- 8	*	D- 6
GASKET	B- 2	HANDLEBAR	D- 5	*	D- 8
*	B- 4	HEAD, cylinder 1	B- 2	NUT, adjusting	C- 8
*	B- 8	HOLDER, handle upper	C-10	NUT, self-locking	C- 3
*	B-10	HOLDER, lever 1	D- 9	*	C- 4
*	B-11	HOLDER, lever 2	D- 9	*	C- 6
*	C-11	HOLDER, lever lower 1	D- 9	*	C- 7

[www.legends-yamaha-enduros.com](http://www.legends-yamaha-enduros.com)

M2



PARTS NAME INDEX

DESCRIPTION	GRID NO.	DESCRIPTION	GRID NO.	DESCRIPTION	GRID NO.
NUT, self-locking	C- 8	PISTON (0.50MM O/S)	B- 3	ROD, connecting	D-12
*	C- 9	*	D-12	ROD, connecting 1	C- 7
*	D- 2	PISTON (STD)	B- 3	ROD, push	C- 8
*	D- 4	*	D-12	ROD, push 1	B-13
NUT, u	D- 3	PISTON ASSY (1ST O/S)	D-12	ROD, push 2	B-13
*	D- 9	PISTON ASSY (2ND O/S)	D-12	ROTOR ASSY	D- 8
NUT, wing	D- 6	PISTON ASSY (STD)	D-12	SCREW	C-13
O-RING	B- 5	PISTON, front fork	C-11	SCREW, bind	B- 9
*	B- 8	PLATE	B-10	SCREW, flat head	B-13
*	B-11	PLATE 1	C- 4	*	B-14
*	C-11	PLATE, bearing cover	B-14	SCREW, hexagon	B- 2
*	C-12	PLATE, brake shoe	D- 2	SCREW, lever fitting	C-13
*	C-13	*	D- 3	SCREW, oval head	D- 5
OIL SEAL	B- 3	PLATE, clutch 1	B-13	SCREW, pan head	B- 4
*	B- 4	PLATE, element fitting	B- 6	*	B- 5
*	B-12	PLATE, friction	B-13	*	B- 6
*	B-13	PLATE, number	C-10	*	B- 8
*	B-14	PLATE, pressure 1	B-13	*	B-10
*	C- 2	PLATE, thrust 1	B-13	*	B-11
*	C- 6	PLUG	B-10	*	C- 4
*	C- 7	PLUG CAP ASSY	D-10	*	C- 5
*	C-11	PLUG, drain	C-11	*	C- 8
*	C-12	*	C-12	*	C-10
*	D- 2	PLUG, oil	B-11	*	C-13
*	D- 3	PLUG, screw	B- 8	*	D- 5
PANEL 1	B- 6	PLUG, spark (CHAMPION N-84)	B- 2	*	D- 8
*	C- 5	PLUG, spark (CHAMPION QN-84)	B- 2	*	D- 9
PEDAL, brake	D- 6	PLUG, straight screw	B-10	*	D-10
PIN	D- 6	PLUNGER, starter	B- 8	SCREW, pan head with washer	B- 6
PIN, clevis	D- 6	PRIMARY DRIVEN GEAR COMP.	B-13	SCREW, tapping	B- 6
PIN, cotter	D- 6	PROTECTOR, muffler 1	B- 9	SCREW, with washer	C- 5
PIN, crank 1	B- 3	PULLER, chain 2	D- 4	*	C-10
*	D-12	RACE, ball 1	C-10	SEAL	B- 6
PIN, dowel	B- 4	RACE, ball 2	C-10	SEAL, dust	C- 8
*	B-10	RADIATOR ASSY	B- 5	*	C-11
*	B-11	REAR ARM COMP.	C- 6	*	C-12
*	C- 2	REED VALVE ASSY	B- 6	SEAL, guard	C- 6
*	C- 8	REED, valve	B- 6	SEAL, pipe 1	B- 5
PIN, float	B- 8	RIM (1.40-17)	D- 2	SEAT, spring lower	C- 8
PIN, piston	B- 3	RIM (1.60-14)	D- 3	SEAT, spring upper	C- 8
*	D-12	RING, piston	B- 3	*	C-11
PIN, straight	B-15	*	C-11	*	C-12
PIPE	B- 8	*	C-12	SEMI-DOUBLE SEAT ASSY	C-15
PIPE 1	B- 5	*	D-12	SHAFT, pivot	C- 6
PIPE 2	B- 5	RING, snap	C-11	SHIFT CAM ASSY	B-15
PIPE, breather	B- 5	*	C-12	SHIFT PEDAL ASSY	C- 2
PISTON (0.25MM O/S)	B- 3	ROD, brake	D- 6	SHIFT SHAFT ASSY	C- 2
*	D-12	ROD, connecting	B- 3	SHIM	C- 6

PARTS NAME INDEX

DESCRIPTION	GRID NO.	DESCRIPTION	GRID NO.	DESCRIPTION	GRID NO.
SHIM 1 (0.6T) .....	B-14	STOPPER, reed valve .....	B- 6	WASHER, plate .....	D- 8
SHOCK ABSORBER ASSY, rear .....	C- 8	SUPPORT, bump stop .....	C- 8	*	D- 9
SILENCER, exhaust .....	B- 9	SUPPORT, chain .....	C- 6	WASHER, spring .....	B- 7
SPACER .....	C-11	SWITCH, handle 1 .....	D- 9	*	B- 8
*	C-12	TENSIONER .....	C- 3	*	B- 9
*	D- 2	THROTTLE SCREW SET .....	B- 8	*	C- 4
*	D- 3	TIRE .....	D- 2	*	C- 5
SPACER, bead .....	D- 2	*	D- 3	*	C-10
*	D- 3	TOOL KIT .....	C- 3	*	C-12
SPINOLE, taper .....	C-11	TOP, mixing chamber .....	B- 8	*	C-13
*	C-12	TUBE (2.75-17) .....	D- 2	*	D- 8
SPOKE SET, front .....	O- 2	TUBE (3.25-14) .....	D- 3	*	D- 9
SPOKE SET, rear .....	D- 3	TUBE (4.10-14) .....	D- 3	*	D-10
SPRING .....	C- 8	TUBE, outer 1 .....	C-11	WASHER, wave .....	C- 8
*	D-11	TUBE, outer 2 .....	C-11	WIRE, earth lead .....	D- 9
SPRING, compression .....	B- 6	TUBE, throttle guide .....	D- 5		
*	B-12	UNDER BRACKET COMP. ....	C-12		
*	B-13	UPPER BRACKET SUB ASSY .....	C- 8		
*	D- 6	VALVE, throttle 1 .....	B- 8		
SPRING, front fork .....	C-11	WASHER .....	B- 3		
*	C-12	*	C- 3		
*	D-11	*	C- 4		
SPRING, rebound .....	C-11	*	D-12		
*	C-12	WASHER 1 .....	B-12		
SPRING, tension .....	B- 9	WASHER, conical spring .....	B-13		
*	D- 2	WASHER, main jet .....	B- 8		
*	D- 3	WASHER, oil seal .....	C-11		
*	D- 6	*	C-12		
SPRING, throttle valve .....	B- 8	WASHER, plain .....	D- 6		
SPRING, torsion .....	B-12	WASHER, plate .....	B- 2		
*	B-13	*	B- 4		
*	B-15	*	B- 5		
*	C- 2	*	B- 6		
*	D- 6	*	B- 9		
*	D- 7	*	B-12		
SPROCKET, drive (12T) .....	B-14	*	B-13		
SPROCKET, drive (13T) .....	B-14	*	C- 3		
SPROCKET, drive (14T) .....	B-14	*	C- 4		
SPROCKET, drive (15T) .....	B-14	*	C- 5		
SPROCKET, driven (44T) .....	D- 3	*	C- 6		
SPROCKET, driven (46T) .....	D- 3	*	C- 7		
SPROCKET, driven (48T) .....	D- 3	*	C- 8		
SPROCKET, driven (50T) .....	D- 3	*	C- 9		
STAND, side .....	D- 6	*	C-13		
STATOR ASSY .....	O- 8	*	D- 2		
STAY, fuel tank 2 .....	C-13	*	D- 4		
STAY, muffler 1 .....	B- 9	*	D- 6		
STOPPER LEVER ASSY .....	B-15	*	D- 7		

[www.legends-yamaha-enduros.com](http://www.legends-yamaha-enduros.com)

